

Fig. 1

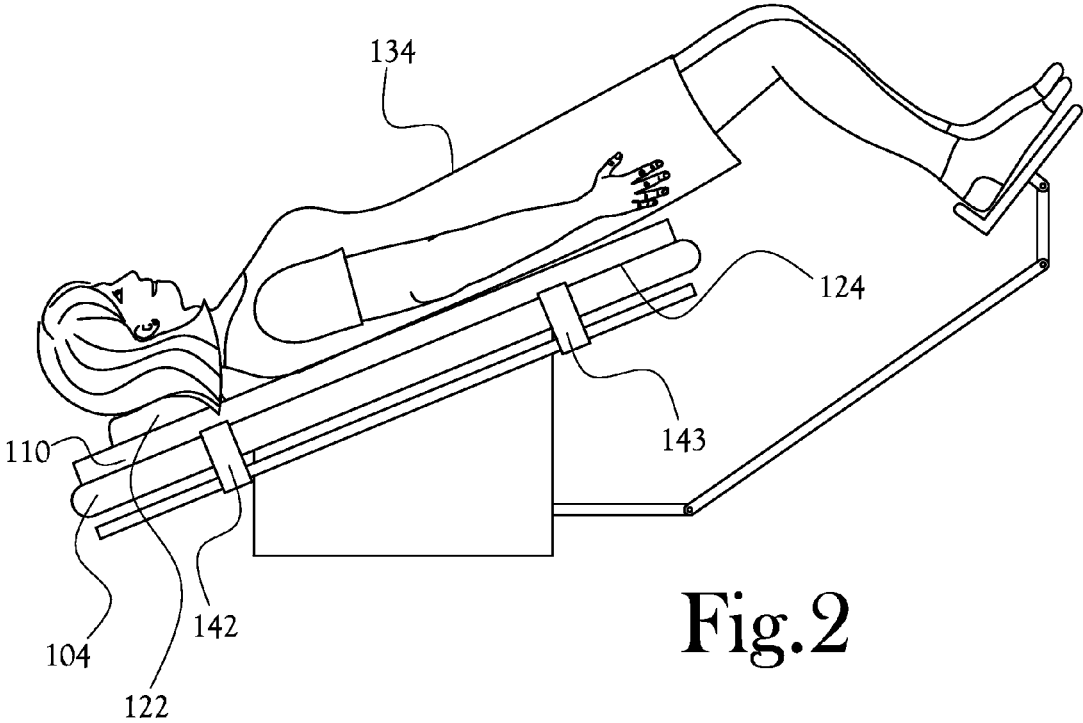

Fig. 2

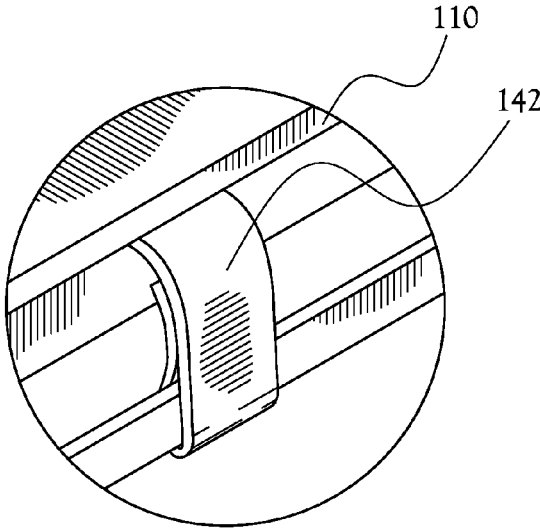

Fig. 3

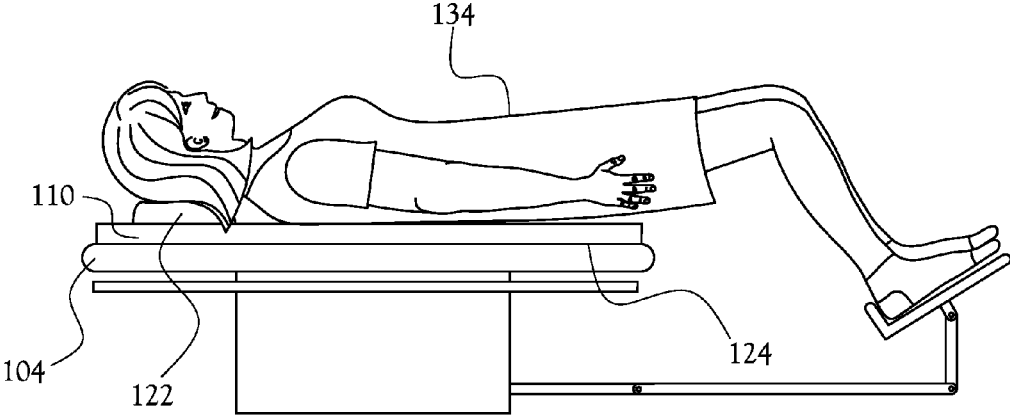

Fig. 4A

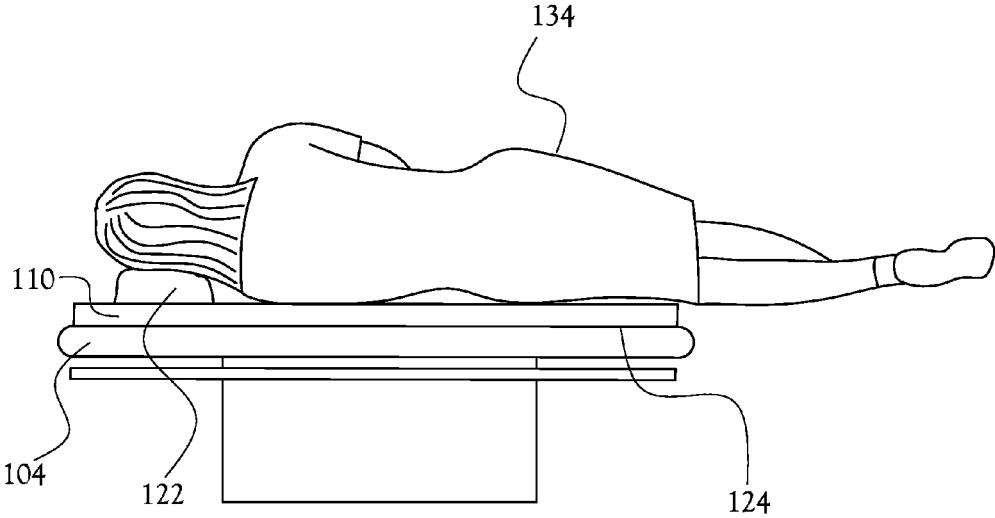

Fig. 4B

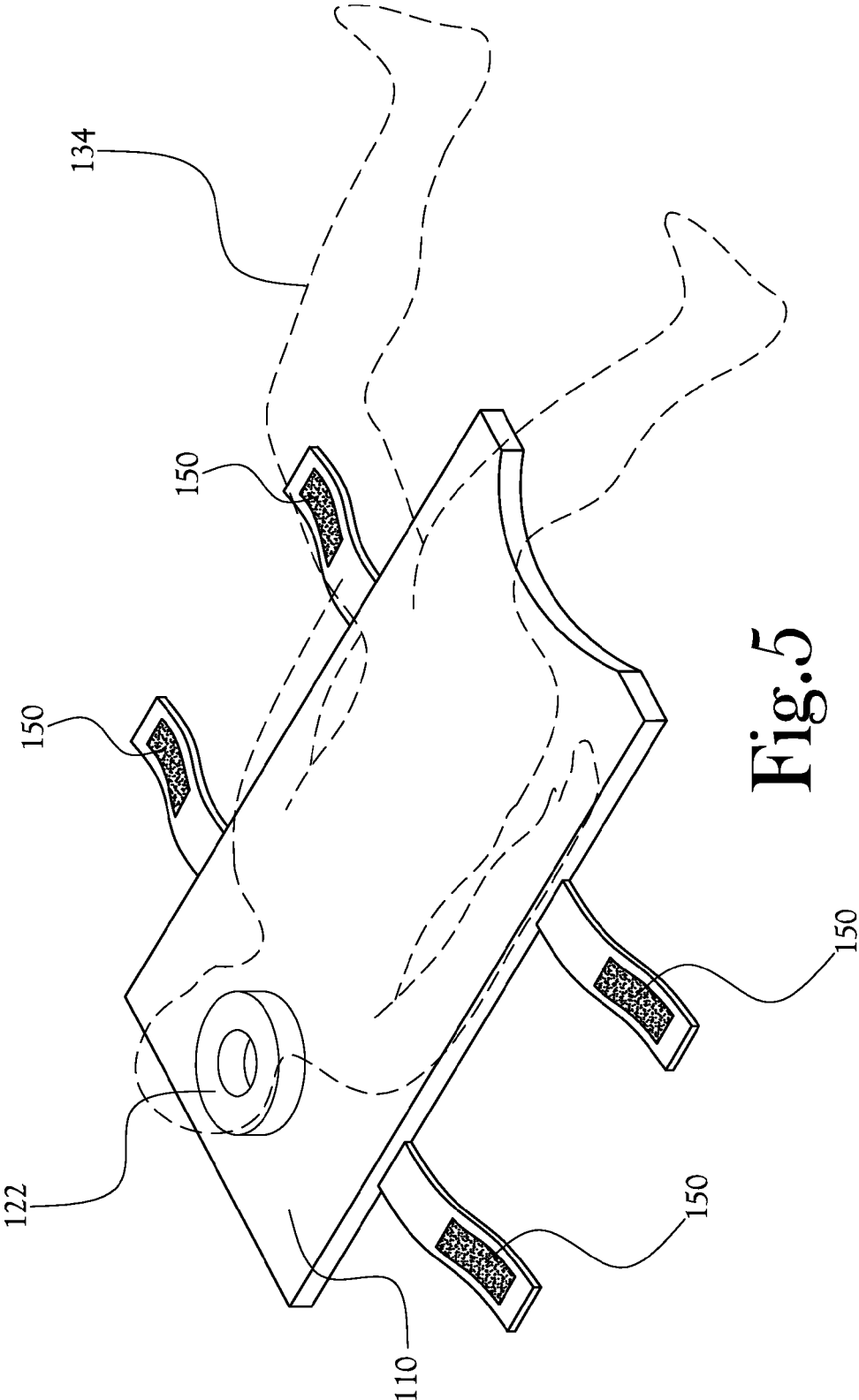

Fig. 5

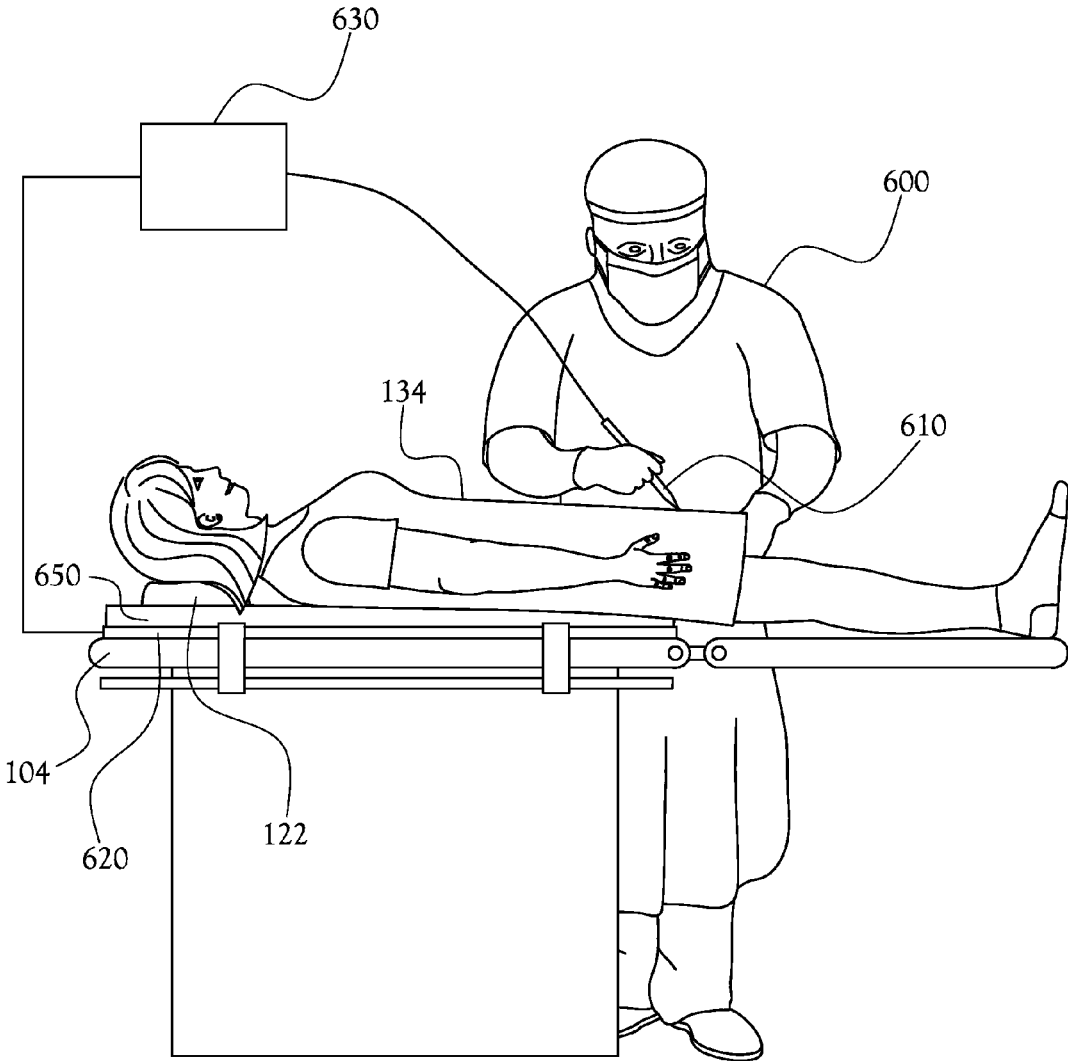

Fig.6

OPERATING ROOM TABLE PAD

CROSS-REFERENCE TO RELATED APPLICATIONS

[0001] This application claims the benefit of U.S. Provisional Patent Application Ser. No. 61/828,974, filed on May 30, 2013, the disclosure of which is incorporated herein in its entirety by reference.

FIELD OF INVENTION

[0002] The present general inventive concept relates to a patient positioning pad to support a patient on an operating room table during a medical procedure.

BACKGROUND OF THE INVENTION

[0003] It is known to provide surface covers for operating tables to support a patient on the operating table during a medical procedure. Efforts regarding such devices have led to continuing developments to improve their versatility, practicality, functionality, efficiency, efficacy, and convenience of use.

BRIEF SUMMARY

[0004] Embodiments of the present general inventive concept provide a surgical pad including a gel-infused foam pad configured in shape and size to support a patient on an operating room table, the gel-infused foam pad having characteristics which improve the versatility, practicality, functionality, efficiency, efficacy, and convenience of use.

[0005] Additional aspects and features of the present general inventive concept will be set forth in part in the description which follows, and, in part, will be obvious from the description, or may be learned by practice of the present general inventive concept.

[0006] Example embodiments of the present general inventive concept may be achieved by providing a surgical pad including a foam pad configured to support a patient on an operating room table, the foam pad comprising a gel-infused polyurethane visco-elastic foam.

[0007] The foam pad may include a perineal cut-out to permit access to the patient's perineum when the patient is lying in a supine position on the foam pad.

[0008] The surgical pad may further include at least one strap configured to secure the foam pad to the table.

[0009] The foam pad may have a density of approximately 3.6 to 3.9 lbs/ft³.

[0010] The perineal cut-out may be approximately semi-circular in shape.

[0011] The cut-out may define an arc less than 180 degrees in circumference, the end points of the arc intersecting an end surface of the surgical pad in two locations to respectively define a pair of equidistant flats extending between the end points and side edges of the surgical pad, respectively.

[0012] Example embodiments of the present general inventive concept may also be achieved by providing a surgical pad for use in an electrosurgical system, the electrosurgical system including an electrosurgical device to deliver an electric current to a patient during an electrosurgical procedure, and a patient return electrode to return the electric current from the patient to the electrosurgical device when the patient is lying on the patient return electrode, the surgical pad comprising gel-infused material, the surgical pad being configured to be interposed between the patient return electrode and the

patient during an electrosurgical procedure to create a low impedance path to conduct electric current from the patient to the patient return electrode during the electrosurgical procedure.

[0013] The surgical pad may be configured to be placed on the patient return electrode on a surgical procedure table to support the patient on the surgical procedure table in a steep Trendelenburg position.

[0014] The surgical pad may include an expanded cellular product including flame retardant polyurethane foam.

[0015] The surgical pad may further include a head receiving portion proximate an anterior end of the surgical pad.

[0016] The surgical pad may further include a recessed portion at a posterior end of the surgical pad that is configured to allow access to the patient's perineum when the patient is in a supine position.

[0017] The recessed portion may be arcuate and substantially centered on a width of the surgical pad.

[0018] The recessed portion may have end-points intersecting the posterior end of the surgical pad to define a pair of flat portions that extend from the end-points to respective corners of the posterior end.

BRIEF DESCRIPTION OF THE FIGURES

[0019] The following example embodiments are representative of example techniques and structures designed to carry out the objects of the present general inventive concept, but the present general inventive concept is not limited to these example embodiments. In the accompanying drawings and illustrations, the sizes and relative sizes, shapes, and qualities of lines, entities, and regions may be exaggerated for clarity. A wide variety of additional embodiments will be more readily understood and appreciated through the following detailed description of the example embodiments, with reference to the accompanying drawings in which:

[0020] FIG. 1 illustrates a table pad according to an example embodiment of the present general inventive concept;

[0021] FIG. 2 illustrates an example use of the table pad of FIG. 1;

[0022] FIG. 3 illustrates a magnified view of a strap of the table pad of FIG. 2 being used to secure the table pad to a surgical table according to an example embodiment of the present general inventive concept;

[0023] FIGS. 4A-4B illustrate two other example uses of the table pad of FIG. 2;

[0024] FIG. 5 illustrates an example positioning of a patient on the table pad of FIG. 1; and

[0025] FIG. 6 illustrates an example use of a table pad according to another example embodiment of the present general inventive concept.

DETAILED DESCRIPTION

[0026] Reference will now be made to various example embodiments of the present general inventive concept, examples of which are illustrated in the accompanying drawings and illustrations. The example embodiments are described herein in order to explain the present general inventive concept by referring to the figures.

[0027] The following detailed description is provided to assist the reader in gaining a comprehensive understanding of the structures and fabrication techniques described herein. Accordingly, various changes, modification, and equivalents

of the structures and fabrication techniques described herein will be suggested to those of ordinary skill in the art. The progression of fabrication operations described are merely examples, however, and the sequence type of operations is not limited to that set forth herein and may be changed as is known in the art, with the exception of operations necessarily occurring in a certain order. Also, description of well-known functions and constructions may be omitted for increased clarity and conciseness.

[0028] Note that spatially relative terms, such as “up,” “down,” “right,” “left,” “beneath,” “below,” “lower,” “above,” “upper” and the like, may be used herein for ease of description to describe one element or feature’s relationship to another element(s) or feature(s) as illustrated in the figures. Spatially relative terms are intended to encompass different orientations of the device in use or operation in addition to the orientation depicted in the figures. For example, if the device in the figures is turned over or rotated, elements described as “below” or “beneath” other elements or features would then be oriented “above” the other elements or features. Thus, the exemplary term “below” can encompass both an orientation of above and below. The device may be otherwise oriented (rotated 90 degrees or at other orientations) and the spatially relative descriptors used herein interpreted accordingly.

[0029] In various example embodiments, the present general inventive concept provides a table pad configured to be used in various medical procedures, the table pad including a foam pad configured to support a patient on an operating room table, and including a gel-infused polyurethane and/or visco-elastic foam at least approximately one inch thick. As used herein, the term “gel-infused” foam refers to what is commonly known as 100% gel-infused polyurethane high density foam. This is distinguishable from foams that merely contain gel beads or other gel components added to the foam without having gel completely mixed into the material.

[0030] FIG. 1 illustrates a table pad according to an example embodiment of the present general inventive concept, and FIG. 2 illustrates an example use of the table pad of FIG. 1. It is noted that the term table pad may be used interchangeably herein with similar terms such as operating table pad, surgical pad, or simply pad. The table pad 110 is configured to be used in any of a number of various medical procedures.

[0031] The example embodiment of the table pad 110 illustrated in FIG. 1, which may be included in or referred to as a surface pad system 100, may be supported by a substantially upward-facing table-top such as a surgical table 104, which may be interchangeably referred to herein as an operating room table, operating table, or simply a table. The table pad 110 of this example embodiment includes a head end 114 (or anterior end), a foot end 118 (or posterior end), a top side 120, and a bottom side 124.

[0032] As used in this description, the phrase “head end” will be used to denote the end of any referred-to object that is positioned to lie nearest the head end of a table-top, and the phrase “foot end” will be used to denote the end of any referred-to object that is positioned to lie nearest the foot end of table-top. Likewise, the phrase “top side” will be used to denote the side of the table pad 110 a patient lies on, and the phrase “bottom side” will be used to denote the side of the table pad 110 lying on the table-top. The pad may be used to provide comfort to a patient 134 when the patient is supported by the surgical table 104, to prevent sliding on the surgical table 104, and so forth.

[0033] In various example embodiments the table pad 110 may be turned over or flipped so that the top and bottom are interchangeable to provide extended use out of a single pad. In various example embodiments, a head resting portion 122, such as any of a host of types of pillows, may be provided proximate the head end 114 of the table pad 110. The head resting portion 122 may be coupled to the table pad 110 by a number of methods, such as adhesive, or may be integrally formed with the table pad 110. In various example embodiments, the head resting portion 122 may be readily detachable such that both sides of the table pad 110 may be interchangeably used as the top side 120.

[0034] Various example embodiments of the present general inventive concept provide a table pad that includes a pressure-reduction foam made from foam rubber and including a thermally active “visco-elastic” foam rubber material. Various example embodiments of the present general inventive concept may provide various different amounts of the thermally active visco-elastic foam rubber material. When the foam rubber included in the table pad is at a warmer temperature the foam is softer and more pliable, and when the foam layer is at a cooler temperature the foam is harder and retains its shape but may tend to conform to the shape of the patient.

[0035] Various example embodiments of the present general inventive concept include a perineal cut-out, or recess portion, 130 that may be useful to permit access to the patient’s perineum when the patient is lying on the foam pad, for example in the supine position, and/or in procedures that require Trendelenburg positioning.

[0036] The cut-out 130 may be utilized for procedures such as exposing a patient’s perineum (i.e., the region between the pubic symphysis and the coccyx). As illustrated in the example embodiment of FIG. 1, the cut-out 130 may be semi-circular with a circular diameter of on the order of 70% of the width of the pad. The radius, or the depth of the circle radius into the end of the pad may be on the order of 35% of the width of the pad. The table pad 110 may be configured to provide sacral contact, or contact with the sacrum, and may be configured to prevent contact between the patient and the table. In various example embodiments, the table pad 110 may have a generally straight shape as illustrated by line 200.

[0037] In the Trendelenburg position a patient is typically laid flat on the back (supine position) with the feet higher than the head, approximately 15-30 degrees from horizontal. According to various example embodiments of the present general inventive concept, the cut-out 130 may be any of a number of types of recess from the otherwise substantially straight edge of the foot-end 118. In the example embodiment illustrated in FIG. 1, the cut-out 130 is configured as an arc having endpoints that are offset from the corners of the edge of the foot-end 118. In other example embodiments, the cut-out 130 may be have larger or smaller widths, depths, and/or configurations, such as having end points proximate to the corners of the table pad 110, or having a less arcuate configuration that may be deeper but have a smaller width.

[0038] According to various example embodiments of the present general inventive concept, and as illustrated in FIG. 1, one or more optional securing straps 140-143 may be provided to the pad on the bottom or top side, or emanating from the edges of the table pad 110. The straps 140-143 may be utilized to assist in holding the table pad 110 stationary when the straps 140-143 are wrapped around and secured to a part of the surgical table 104, such as the safety rails of the surgical table 104.

[0039] FIG. 3 illustrates a magnified view of one of the optional straps 140-143 of the table pad 110 of FIG. 2 being used to secure the table pad 110 to the surgical table 104 according to an example embodiment of the present general inventive concept. According to various example embodiments, the securing of the straps 140-143 may be accomplished by any number of configurations/methods, such as utilizing hook-and-loop fabric fasteners and may include two components such as two lineal fabric strips (or, alternatively, round "dots" or squares) which are attached (e.g., sewn, adhered, etc.) to the opposing surfaces to be fastened. In an example embodiment, the first component may feature tiny hooks, and the second component may feature loops. When the two components are pressed together, the hooks catch in the loops and the two pieces fasten or bind temporarily. Separation may be by pulling or peeling the two strips apart. The straps 140-143 may be coupled to the table pad 110 in any of a host of configurations, such as, for example, utilizing an adhesive, being formed integrally with the table pad 110, and so on. In other various example embodiments, the straps 140-143 may be available to optionally add to the table pad 110, such as by hook and loop adhesion points, or by threading through a slit provided in the table pad 110, and so on. The optional straps 140-143 may be utilized for pad immobilization during patient transfer or interoperative procedural use, but it is understood the composition of the pad typically does not require any straps for pad immobilization.

[0040] In various example embodiments, the table 110 pad may be approximately 1 inch thick or more, and may have no foam "memory". For example, it is possible to roll-up the pad for shipping and/or storage convenience, and then unroll the pad for use, where the pad is capable of lying flat on the table surface without portions of the pad having a tendency to lift-off the table surface due to memory from the rolled-up position.

[0041] In various example embodiments, the pad may include an expanded cellular product such as a flame retardant polyurethane foam. The density may be considered a high density foam on the order of 3.6 to 3.9 lbs/ft³ with a Differential Pressure Air Permeability (ASTM D3574 test) of on the order of approximately 7 to 13.

[0042] The surgical pad may be a gel-infused polyurethane or visco-elastic foam. Such a foam is designed to absorb and distribute pressure from a patient. It also provides support which may evenly distribute body weight and provide long lasting durability. It may wick away body heat to aid in consistent sleep temperature, provide stability, and reduce motion transfer.

[0043] When a patient lies down, the table pad 110 (having infused gel therein) may be depressed from downwardly projecting portions of the patient that result in high interface pressure points between the patient and patient-support surface. This movement away from high interface pressure points and toward lower pressure interface points operates to increase the surface area of contact between the patient and table to minimize the interface pressure at high interface pressure points between the patient and patient-support surface. Maximizing the surface area of contact between the patient and patient-support surface also maximizes the conductive heat transfer between the patient and patient-support surface. Although various example embodiments of the present general inventive concept have been described as being used in Trendelenburg positioning, it is understood that

various features of the present general inventive concept are valuable in a number of other positions and/or procedures.

[0044] FIGS. 4A-4B illustrate example uses of the table pad 110 of FIG. 2. FIG. 4A illustrates a patient in the supine position, with feet in stirrups, but being positioned in a substantially horizontal position, and FIG. 4B illustrates a patient on her side in a substantially horizontal position. These figures illustrate merely two example patient positions which may be utilized with the table pad 110 of the present general inventive concept, but the present table pad 110 is not limited to any particular patient size or position to provide increased comfort, weight distribution, and reduced sliding on a surgical table.

[0045] FIG. 5 illustrates an example positioning of a patient on the table pad of FIG. 1 in an outline manner to better see the positioning of the various areas of the patient relative to the parts of the table pad 110. The positioning of the patient in FIG. 5 is similar to the Trendelenburg positioning, and shows the cut-out 130 as providing improved access to the perineal region of the patient. In the example embodiment illustrated in FIG. 5, the straps 140-143 have been provided with a hook and loop fastening portion 150 to secure the table pad 110 to the surgical table 104.

[0046] Use of a surface pad system 100 such as the one illustrated in FIG. 1 may minimize the interface pressure of the high interface pressure points between the patient and patient-support surface, such as the surgical table 104. The weight of a patient supported on a conventional surface cover for a surgical table 104 is supported primarily by the head, shoulder blades and sacrum. The above-noted portions of the patient are the downwardly extending extremities of the patient when resting on a conventional surface cover for a surgical table 104 and, as a result, these extremities of the patient support most of the weight of the patient and experience the highest interface pressure between the patient and patient-support surface. It can also be seen that several portions of the patient have low interface pressures against patient-support surface and even no contact with patient-support surface. Use of a surface pad system 100 according to various example embodiments of the present general inventive concept may minimize pressure ulcers, neuropathy, and/or other nerve disorders and damage to nerve bundles that may result from prolonged exposure to high interface pressures.

[0047] In various example embodiments of the present general inventive concept, the table pad 110 may include a gel-infused, heat wicking foam pad that evenly distributes patient body weight along the table pad 110 to provide support and stability, wherein the composition may substantially prevent motion transfer. Such a property may be advantageous, for example, in steep Trendelenburg positioning.

[0048] In various example embodiments the table pad 110 may be a thermally active shock absorbing polyurethane visco-elastic foam. Visco-elastic foam may be formulated so that the firmness and support characteristics of the foam may maintain a generally constant durometer hardness and which provides the same support and firmness characteristics at different operating temperatures. The table pad 110 may easily conform to the shape of the patient carried on the table surface even if the position of the patient is temporarily changed. In various example embodiments, the table pad 110 may be formed from a unitary foam piece, or from a plurality of sections, such as foam blocks.

[0049] In various example embodiments, the table pad 110 may be made from a thermally active shock absorbing poly-

urethane foam that is formulated as a visco-elastic foam. Thus, the support and firmness characteristics of the foam pad may easily conform to the shape of the patient carried on the table.

[0050] In various example embodiments of the present general inventive concept, the table pad **110** may be formed of or include a low-impedance material to provide a low impedance path to conduct electric current between the patient and a patient return electrode during electrosurgical procedures. For purposes of the present disclosure, the term “patient return electrode” refers to a pad style that lays flat on a surgical table and provides maximum patient contact without adhesives, rather than other styles of patient return electrodes that may be smaller and use adhesives to remain in contact with the patient. Such electrosurgical systems typically provide an electrosurgical device to deliver an application of a high-frequency electric current to biological tissue as a means to cut, coagulate, desiccate, or fulgurate tissue. During these procedures, the table pad **110** may be interposed between the patient return electrode create reduced, and, in various example embodiments, approaching minimal, impedance during the “cut” mode of electrocautery pens used to stop bleeding at a surgical site. Because of such a feature, the table pad **110** offers enhanced electrocautery compatibility along with patient safety and the convenience of disposable pads.

[0051] FIG. 6 illustrates an example use of a table pad according to the example embodiment of the present general inventive concept in which the table pad **650** includes a low-impedance material such as, for example, an infused gel. In FIG. 6, a surgeon **600** is performing an electrosurgical procedure using an electrocautery pen **610**, from which a current moves to a patient return electrode **620**, and the low-impedance and resilient table pad **650** is located between the patient **134** and the patient return electrode **610**. The electrocautery pen **610** and the patient return electrode **620** are in electrical communication with a power source **630** which provides power to the electrocautery pen **610**. As illustrated in FIG. 6, the table pad **650** provides comfort and slide-reducing properties, and also a low-impedance to provide minimal interference with the electrosurgery being performed.

[0052] Regarding the ability to provide disposable low-impedance table pads, the use of lithotomy steep Trendelenburg (LST) positioning has increased in recent times due to enhancements in robotic procedures. Such positioning takes careful planning and consideration to protect the patient from sliding or developing shearing type skin injuries. According to AORN Recommended Practices on Positioning the Patient, “measures should be taken to prevent patient from sliding on the procedural bed. Risk for shear injuries increase when changing the patient’s position from supine to Trendelenburg and to prevent injury to the shoulders, shoulder braces should be avoided.” Thus, the table pad **110** formed of low impedance material according to various examples of the present general inventive concept may minimize patient movement during LST procedures, as well as providing reduced interference with a current between electrocautery pens and a patient return electrode. Conventional positioners that are too thick may decrease the electrosurgical current and result in poor coupling between the patient and the patient return electrode. And, when LST positioning is required, it is important to stabilize the patient return electrode and use it in conjunction with other anti-slide materials, such as the table pad **110**, in order to achieve the best outcome.

[0053] In one example use of the low-impedance table pad **110** of the present general inventive concept, the patient return electrode may be placed against the surgical table **104** without sheets or other materials. A patient safety strap or a surgical towel with adhesive tape may be used to secure the patient return electrode to the table. The table pad **110** may be placed on top of the patient return electrode, in some cases without sheets or other materials (or, in some cases, with a single folded sheet for tucking the patient’s arms). The straps **140-143** may be secured to the metal railing of the surgical table **104** securely against the bolted anchors to prevent pad movement during positioning. The patient may then be laid on the table pad **110** without sheets or gowns between the patient and the table pad **110**. The use of sheets between the patient and the patient return electrode, such as lift sheets, may be undesirable due to the added impedance which would reduce the conductivity of electric current flowing from the patient to the patient return electrode and reduce effectiveness of the electrosurgery procedure.

[0054] The patient may be monitored during positioning and intraoperatively to assess for patient movement, so that the table pad **110** may be adjusted if necessary. The materials of which the table pad **110** is constructed according to various example embodiments of the present general inventive concept aid in the prevention of slipping or other movement of the patient relative to the surgical table **104** and/or the patient return electrode, and have the added convenience of being disposable, as well as reducing pressure points to make the patient more comfortable.

[0055] It is noted that the simplified diagrams and drawings do not illustrate all the various connections and assemblies of the various components, however, those skilled in the art will understand how to implement such connections and assemblies, based on the illustrated components, figures, and descriptions provided herein, using sound engineering judgment.

[0056] Numerous variations, modifications, and additional embodiments are possible, and accordingly, all such variations, modifications, and embodiments are to be regarded as being within the spirit and scope of the present general inventive concept. For example, regardless of the content of any portion of this application, unless clearly specified to the contrary, there is no requirement for the inclusion in any claim herein or of any application claiming priority hereto of any particular described or illustrated activity or element, any particular sequence of such activities, or any particular interrelationship of such elements. Moreover, any activity can be repeated, any activity can be performed by multiple entities, and/or any element can be duplicated.

[0057] While the present general inventive concept has been illustrated by description of several example embodiments, it is not the intention of the applicant to restrict or in any way limit the scope of the inventive concept to such descriptions and illustrations. Instead, the descriptions, drawings, and claims herein are to be regarded as illustrative in nature, and not as restrictive, and additional embodiments will readily appear to those skilled in the art upon reading the above description and drawings.

1. A surgical pad to support a patient on an operating room table, comprising:

a gel-infused polyurethane visco-elastic foam configured to support a patient on an operating room table; and

- a perineal cut-out to permit access to the patient's perineum when the patient is lying in a supine position on the surgical pad.
2. The surgical pad of claim 1, further comprising at least one strap configured to secure the surgical pad to the table.
3. The surgical pad of claim 1, wherein the foam has a density of approximately 3.6 to 3.9 lbs/ft³.
4. The surgical pad of claim 1, wherein the perineal cut-out is approximately semi-circular in shape.
5. The surgical pad of claim 4, wherein the perineal cut-out defines an arc less than 180 degrees in circumference, the end points of the arc intersecting an end surface of the surgical pad in two locations to respectively define a pair of equidistant flats extending between the end points and opposing side edges of the surgical pad, respectively.
6. The surgical pad of claim 1, wherein the foam is a gel-infused foam.
7. The surgical pad of claim 6, wherein the gel-infused foam includes flame retardant polyurethane foam.
8. The surgical pad of claim 7, wherein the surgical pad is configured to be rolled-up for shipping and/or storage, and is configured to return to its original flat shape immediately upon being unrolled.
9. A surgical pad for use in an electrosurgical system, the electrosurgical system including an electrosurgical device to deliver an electric current to a patient during an electrosurgical procedure, and a patient return electrode to return the electric current from the patient to the electrosurgical device when the patient is lying on the patient return electrode, the

surgical pad comprising gel-infused material, the surgical pad being configured to be interposed between the patient return electrode and the patient during an electrosurgical procedure to create a low impedance path to conduct electric current from the patient to the patient return electrode during the electrosurgical procedure.

10. The surgical pad of claim 9, wherein the surgical pad is configured to be placed on the patient return electrode on a surgical procedure table to support the patient on the surgical procedure table in a steep Trendelenburg position.

11. The surgical pad of claim 9, wherein the surgical pad comprises an expanded cellular product including flame retardant polyurethane foam.

12. The surgical pad of claim 9, further comprising a head receiving portion proximate an anterior end of the surgical pad.

13. The surgical pad of claim 9, further comprising a recessed portion at a posterior end of the surgical pad that is configured to allow access to the patient's perineum when the patient is in a supine position.

14. The surgical pad of claim 13, wherein the recessed portion is arcuate and substantially centered between opposing side surfaces that define a width of the surgical pad.

15. The surgical pad of claim 14, wherein the recessed portion has end-points intersecting the posterior end of the surgical pad which respectively define a pair of flat portions that extend from the end-points to the opposing side surfaces, respectively.

* * * * *