



(19) **United States**

(12) **Patent Application Publication**

Kane

(10) **Pub. No.: US 2021/0082219 A1**

(43) **Pub. Date: Mar. 18, 2021**

(54) **METHOD AND SYSTEM FOR SECURELY RECEIVING DELIVERIES**

(52) **U.S. Cl.**
CPC **G07C 9/00896** (2013.01); **G07C 9/00182** (2013.01); **E06B 7/32** (2013.01); **E05Y 2900/106** (2013.01); **G07C 2009/00928** (2013.01); **E05Y 2400/66** (2013.01); **E05B 65/006** (2013.01)

(71) Applicant: **Jacqueline Kane**, Atlantic Beach, FL (US)

(72) Inventor: **Jacqueline Kane**, Atlantic Beach, FL (US)

(21) Appl. No.: **17/104,743**

(57) **ABSTRACT**

(22) Filed: **Nov. 25, 2020**

Related U.S. Application Data

(63) Continuation-in-part of application No. 16/459,550, filed on Jul. 1, 2019, now Pat. No. 10,878,647.

(60) Provisional application No. 62/712,114, filed on Jul. 30, 2018.

Publication Classification

(51) **Int. Cl.**
G07C 9/00 (2006.01)
E06B 7/32 (2006.01)
E05B 65/00 (2006.01)

The present disclosure relates generally to a system and method for receiving packages through the mail when a person is not home. More specifically, the present disclosure provides a system for a person to facilitate safe and secure delivery to a receiving module without needing to be present. In some aspects, an administrator may control the module from a portable smart device or other wireless device. The receiving module may be operated digitally, manually, virtually, or combinations thereof. The settings of the receiving module may be controlled by a recipient, delivery service, sender, or combinations thereof. In some embodiments, the receiving module may be installable on a garage door.

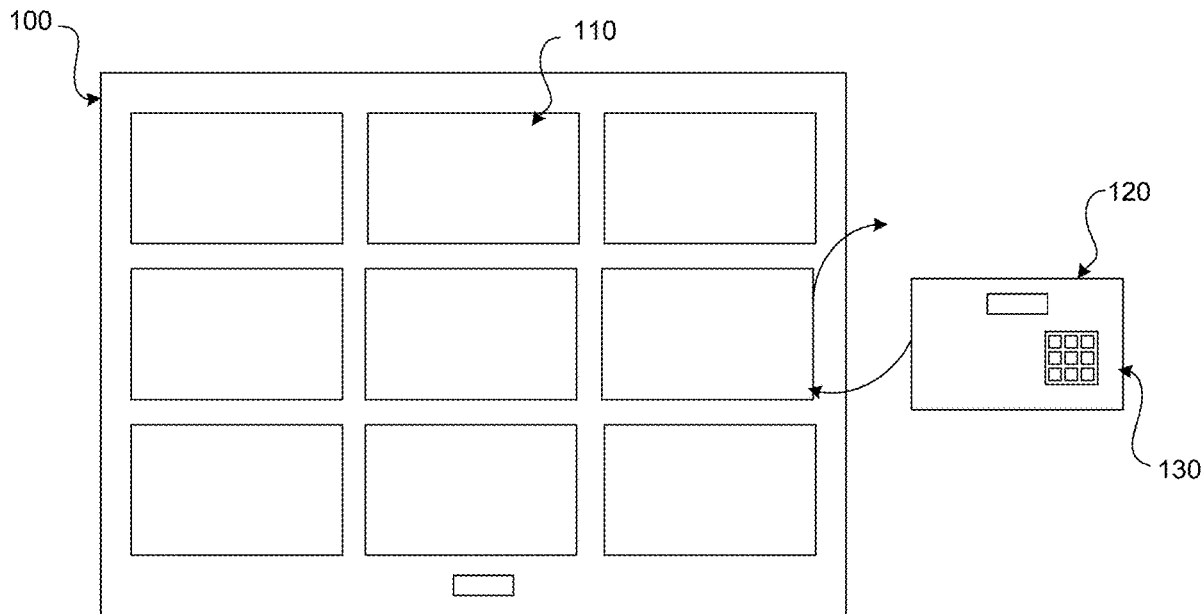

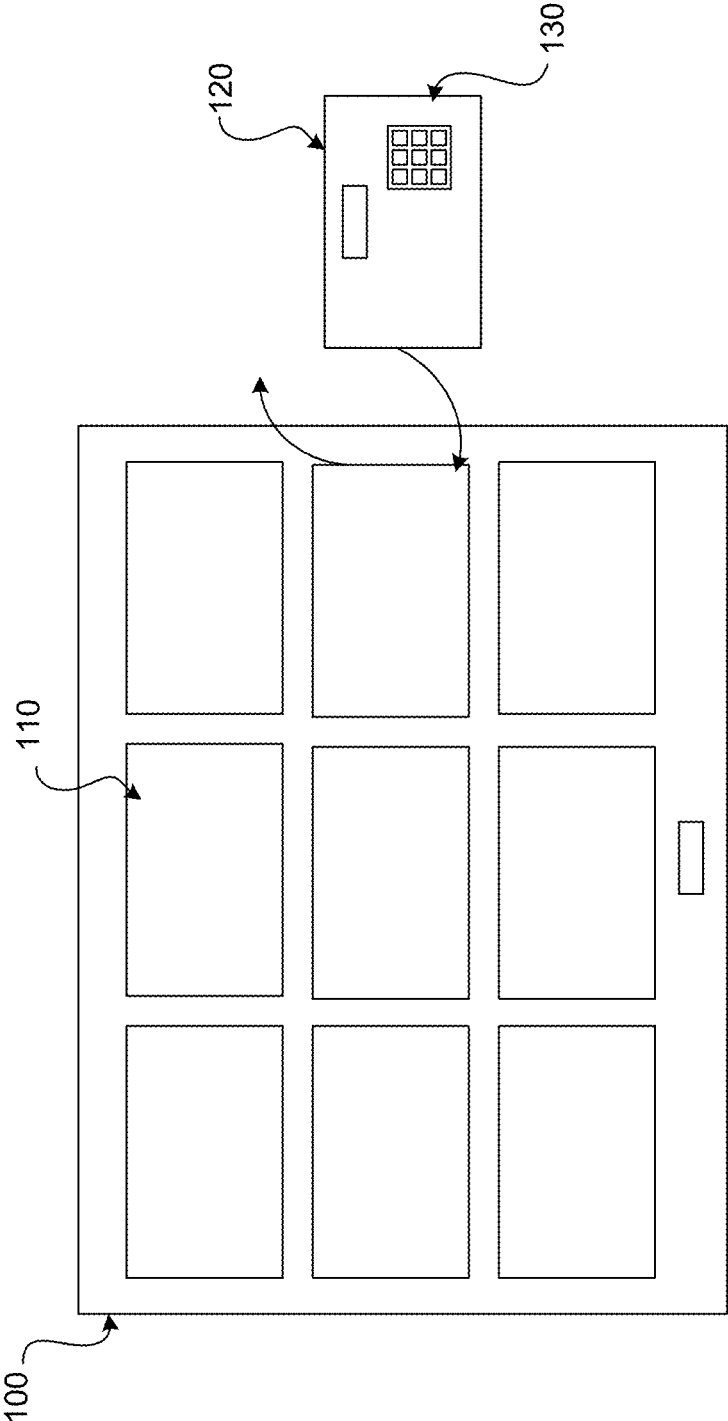

FIG. 1

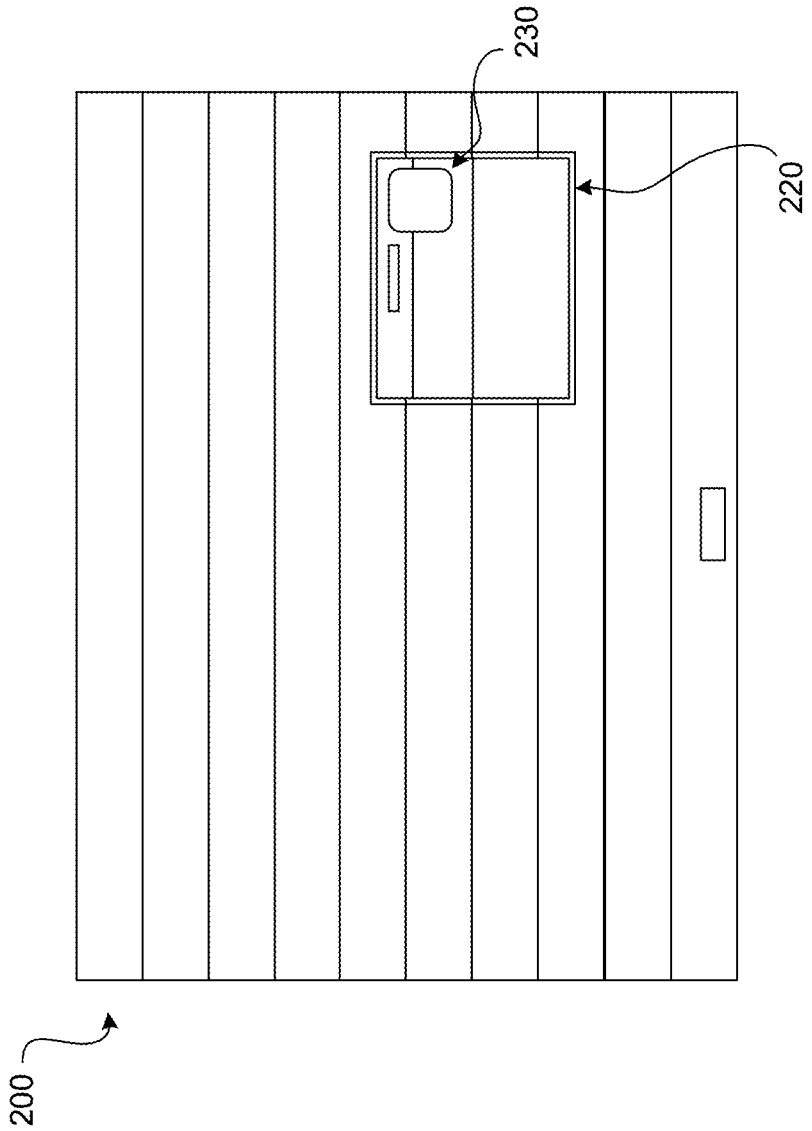

FIG. 2

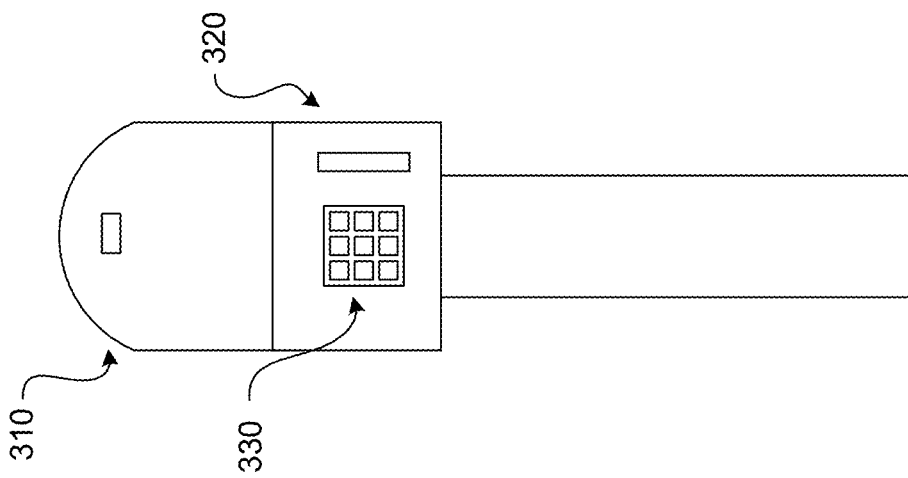

FIG. 3

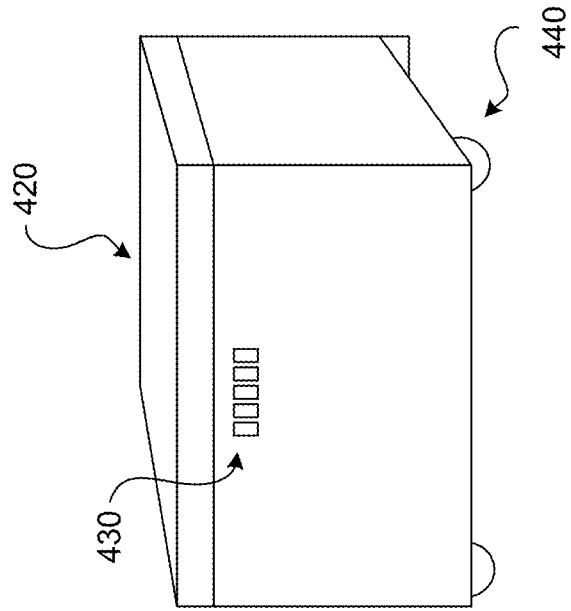

FIG. 4

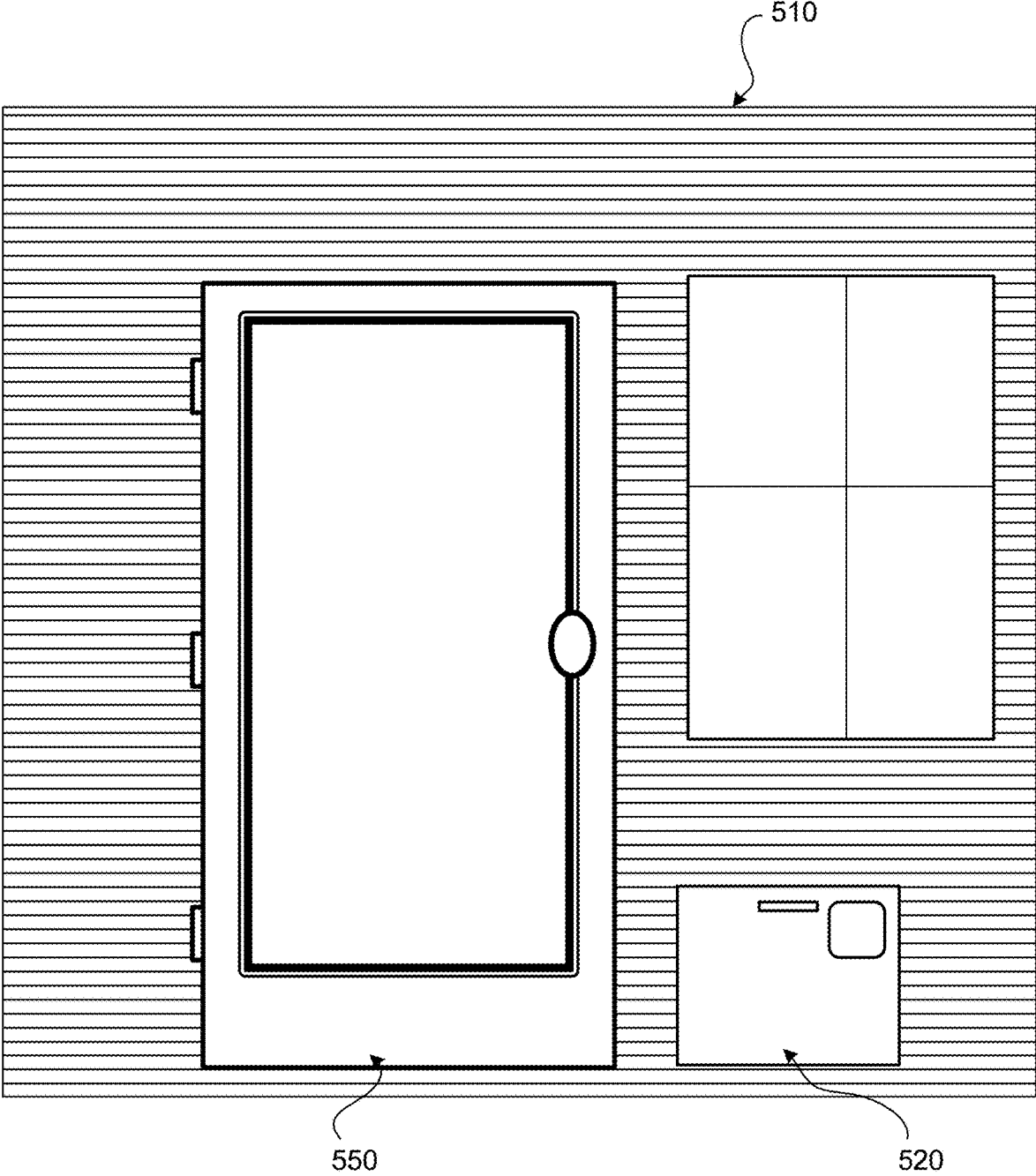

FIG. 5

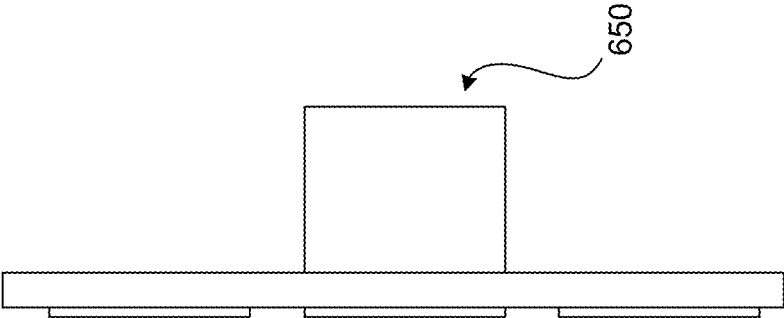

FIG. 6C

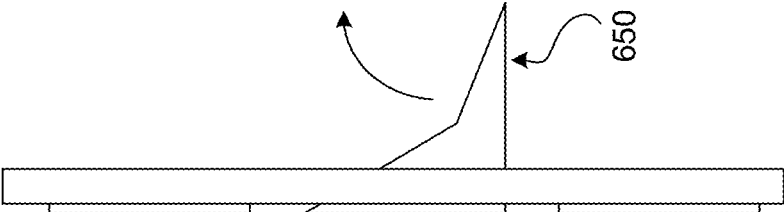

FIG. 6B

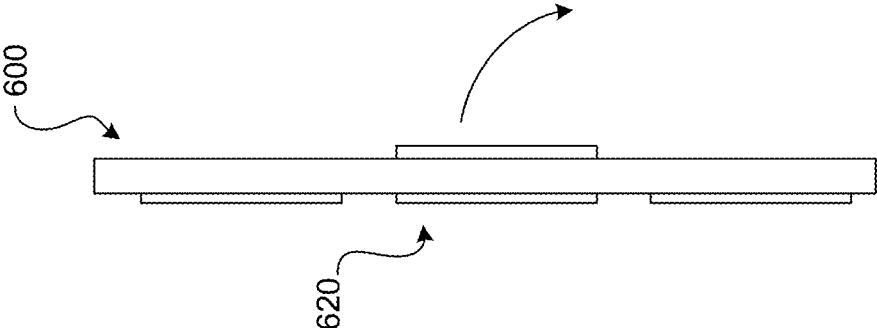

FIG. 6A

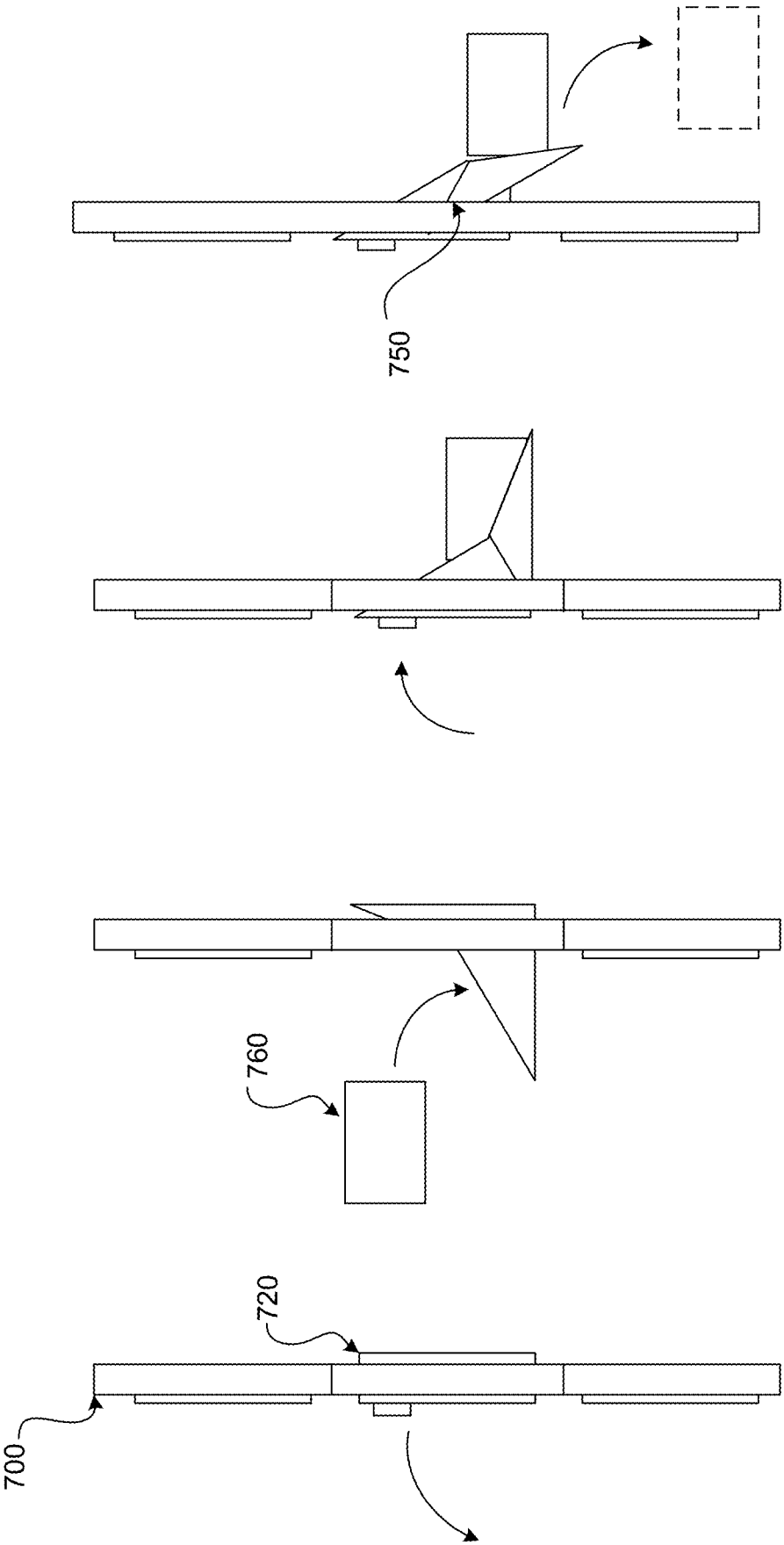

FIG. 7D

FIG. 7C

FIG. 7B

FIG. 7A

FIG. 8

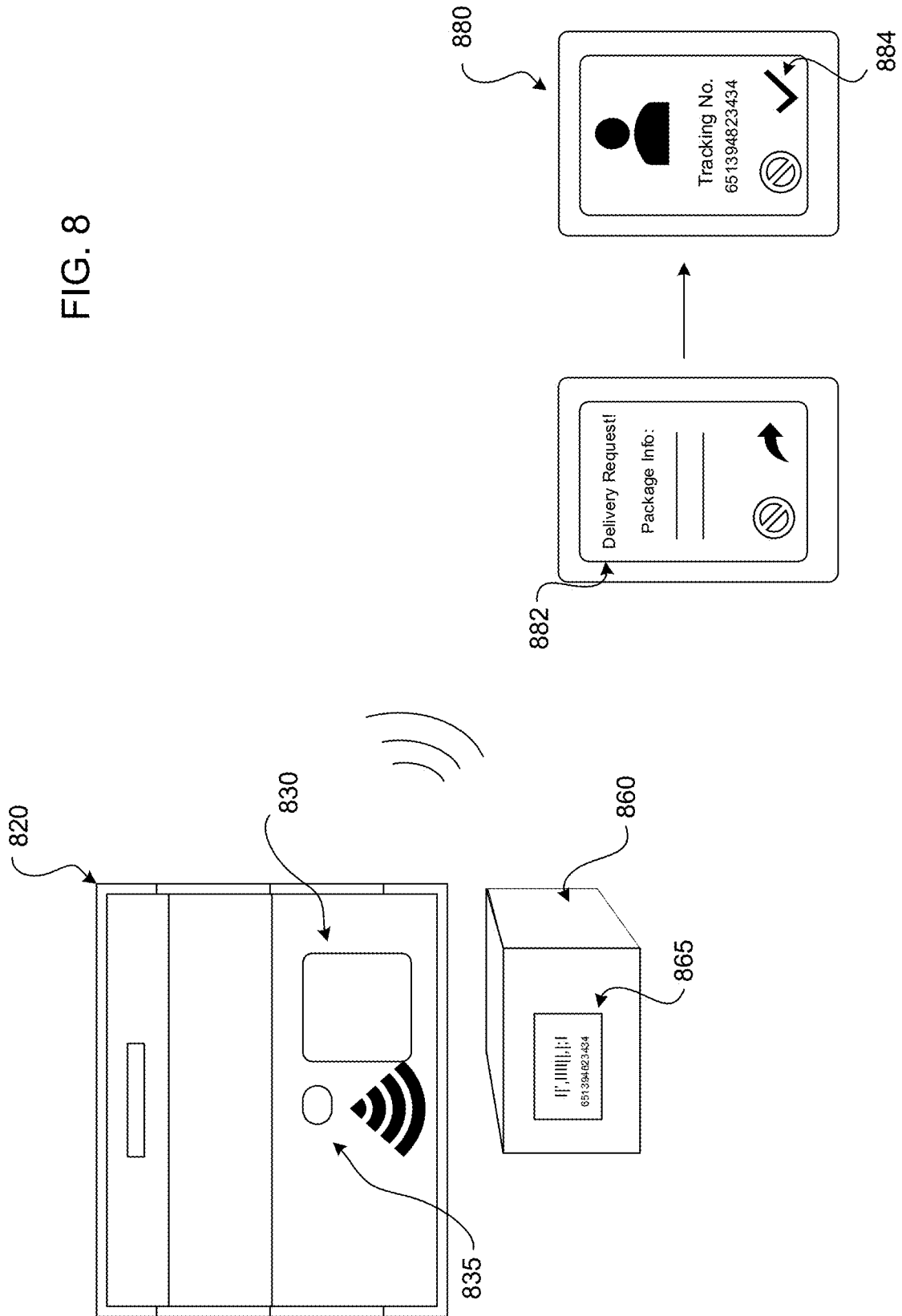

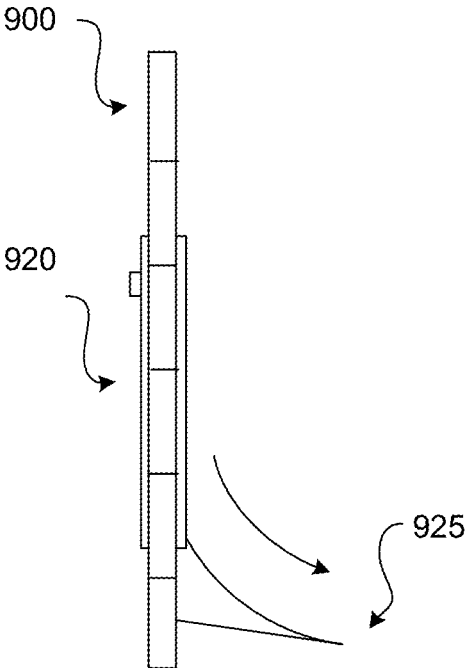
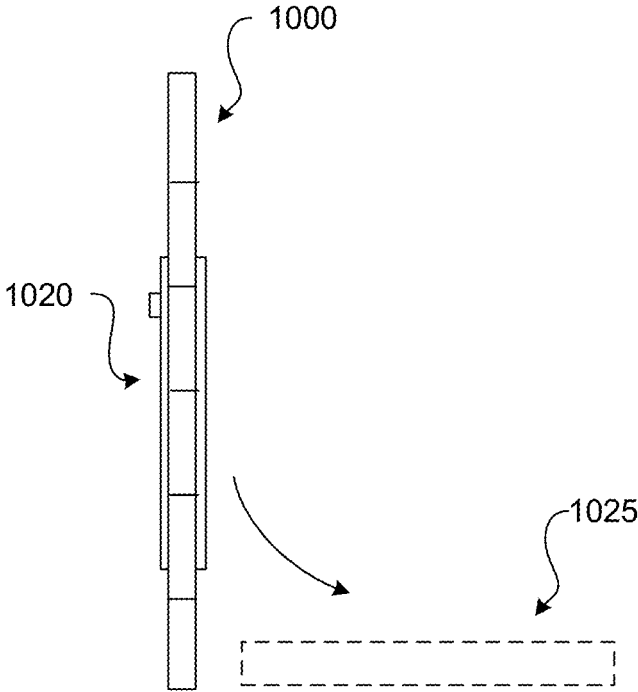

FIG. 9

FIG. 10



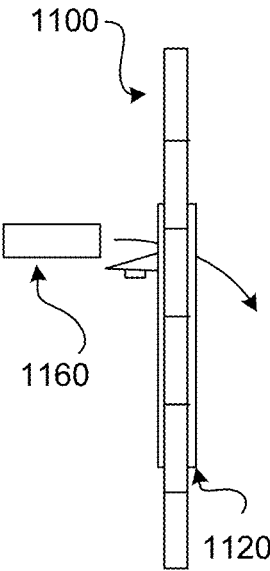

FIG. 11A

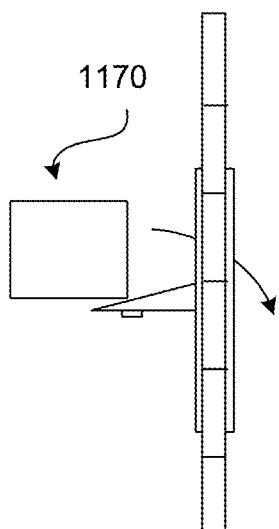

FIG. 11B

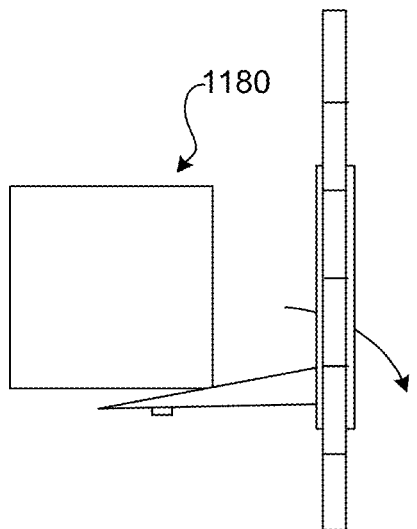

FIG. 11C

FIG. 12A

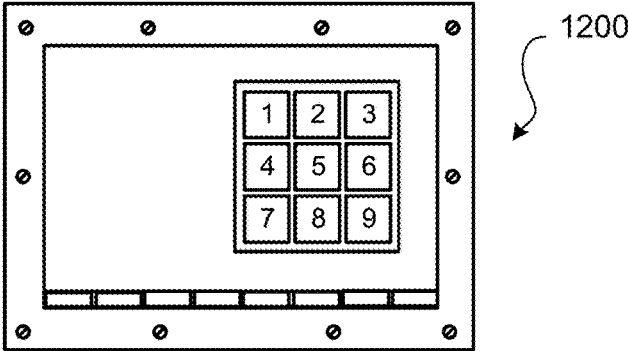

FIG. 12B

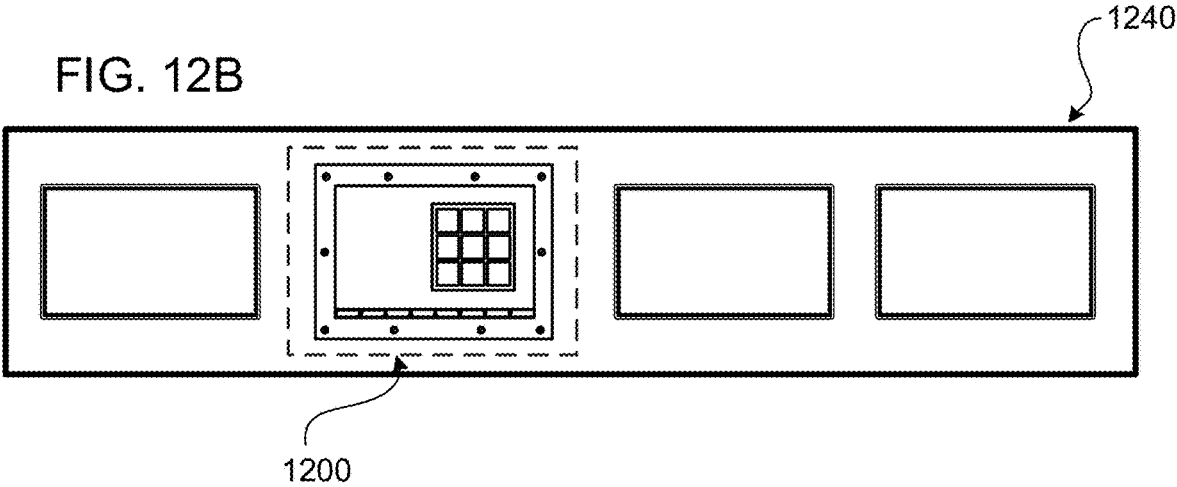
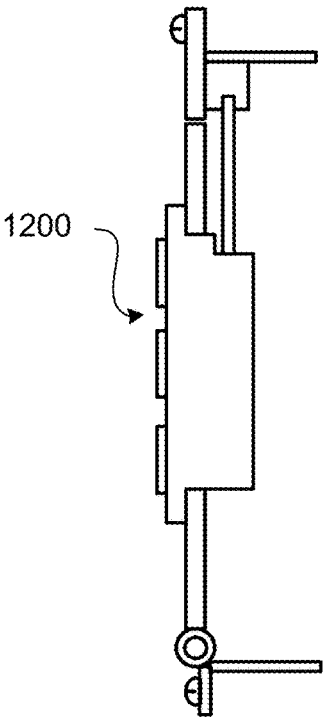

FIG. 12C



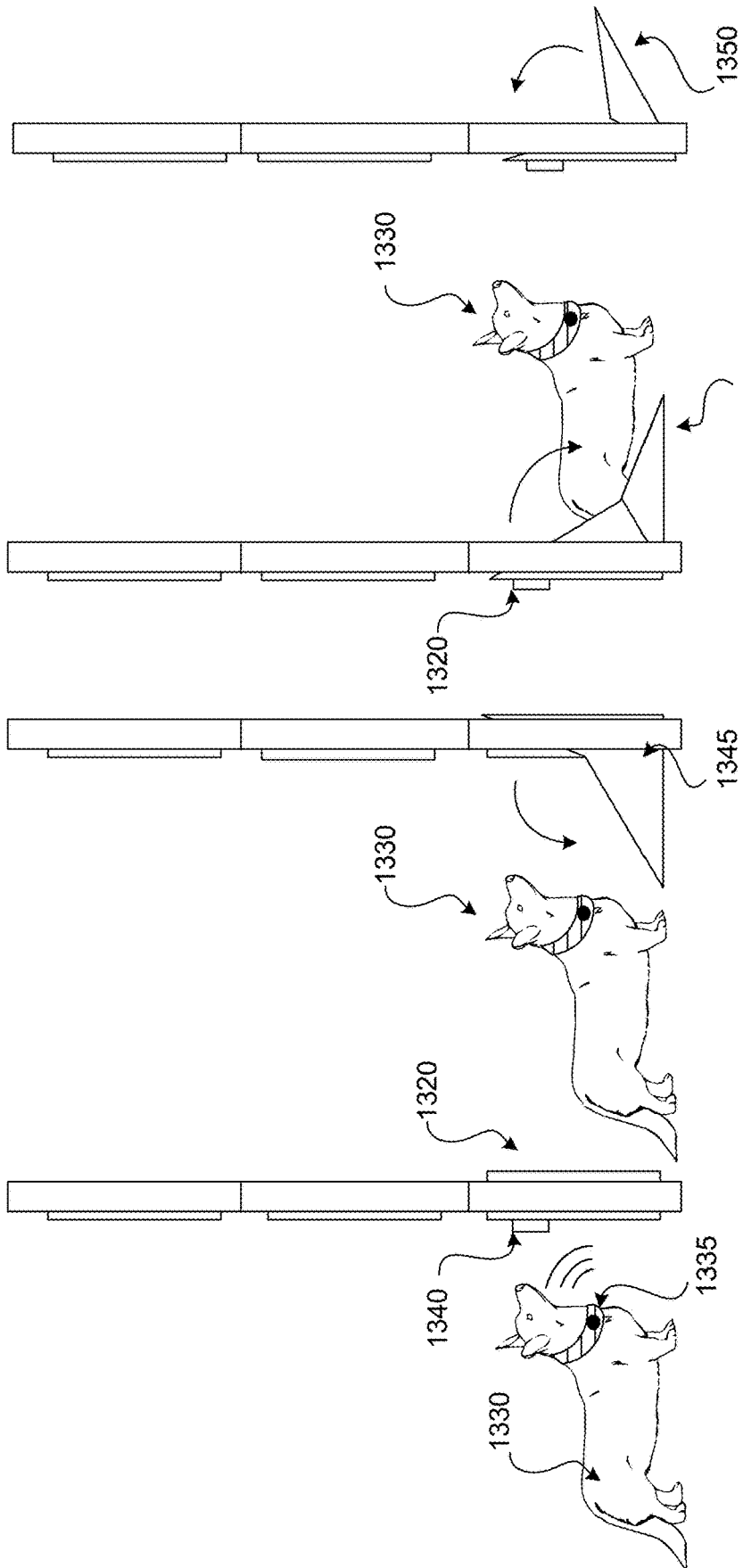

FIG. 13D

FIG. 13C

FIG. 13B

FIG. 13A

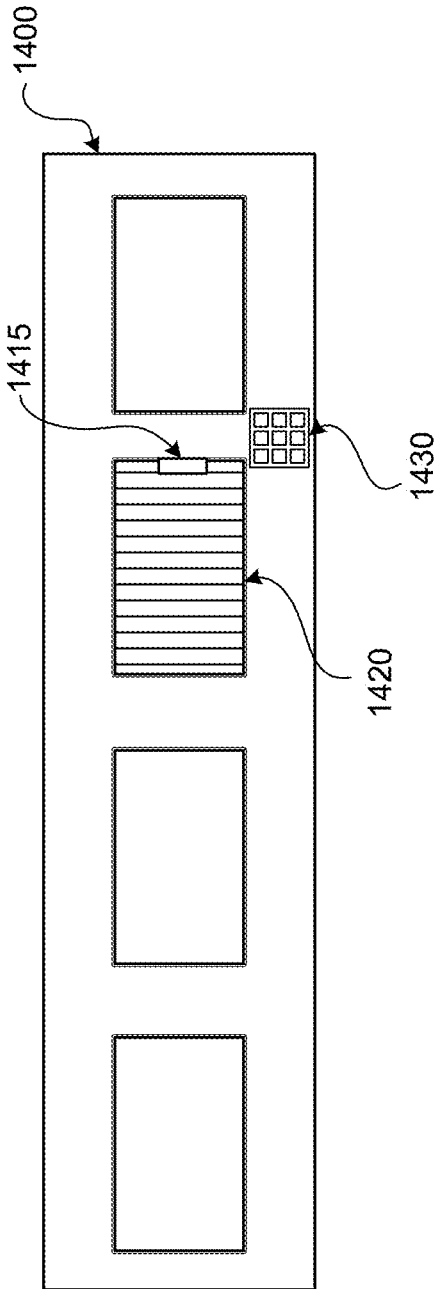

FIG. 14A

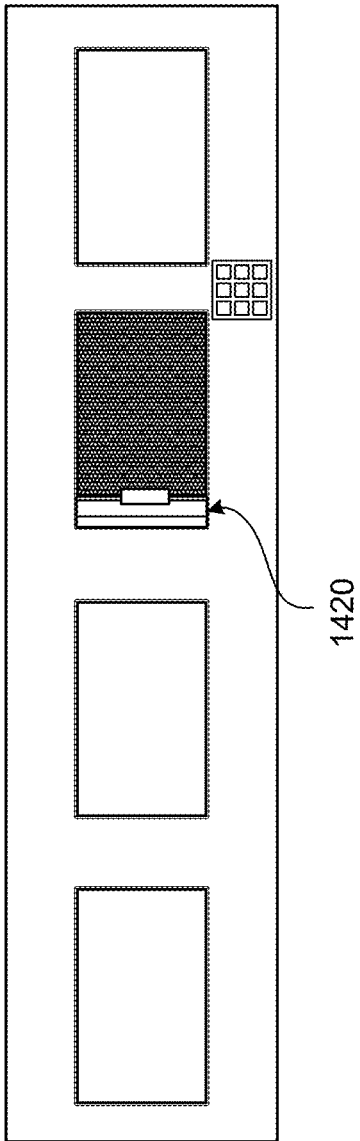

FIG. 14B

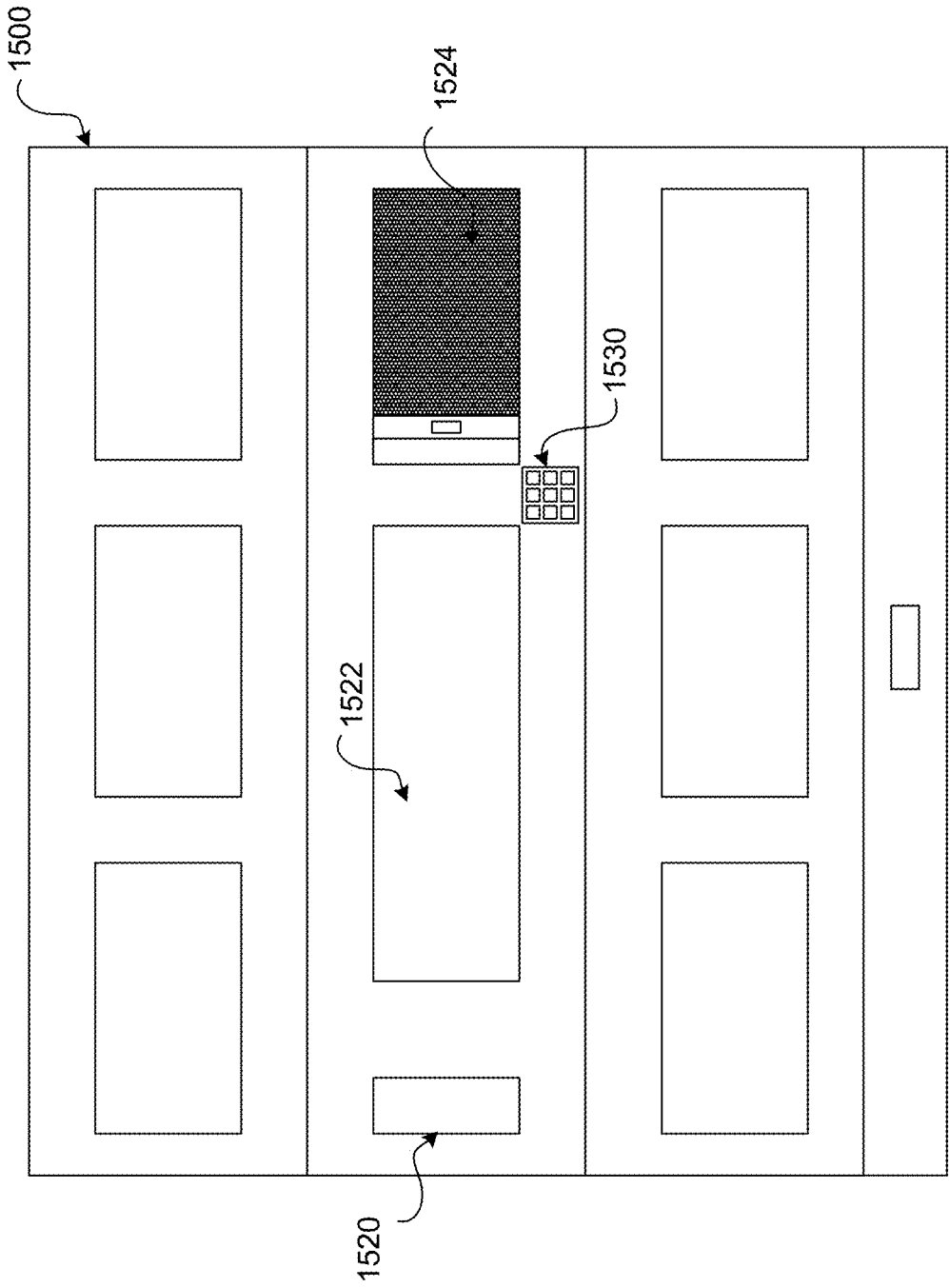

FIG. 15

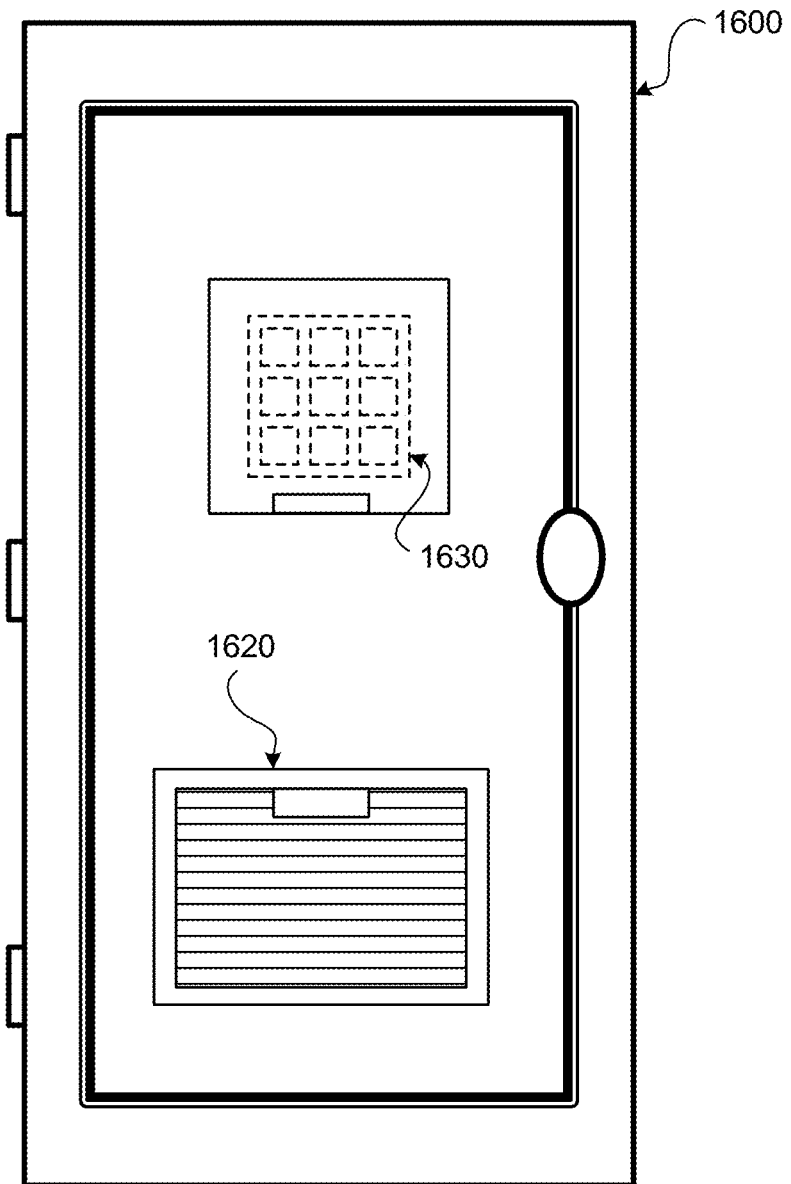

FIG. 16

1720

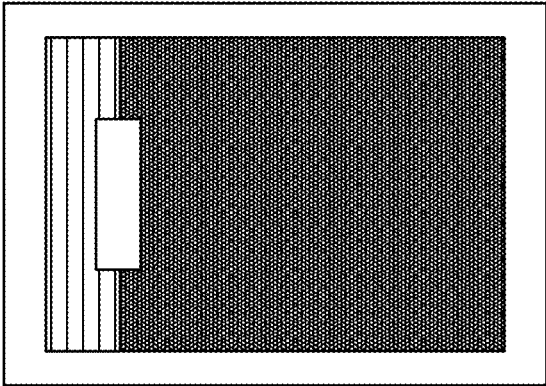

FIG. 17A

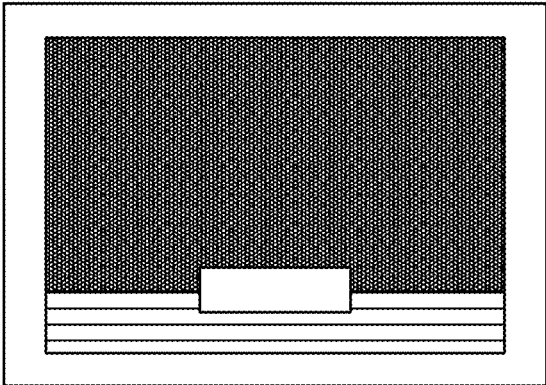

FIG. 17B

1820

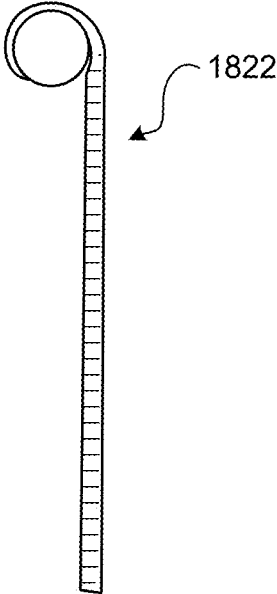

FIG. 18A

1820



FIG. 18B

1920

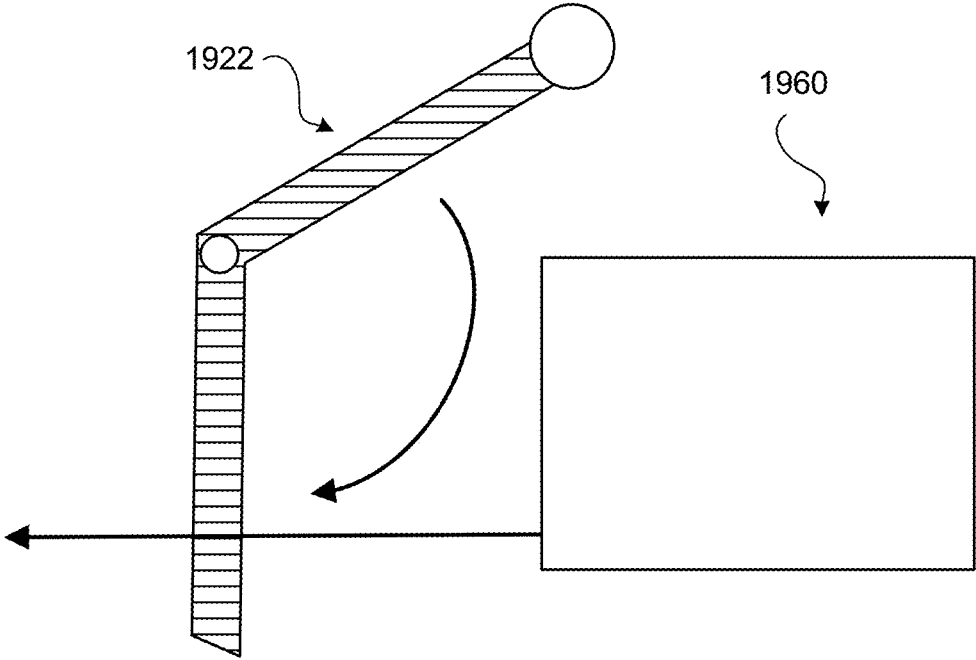

FIG. 19

2020

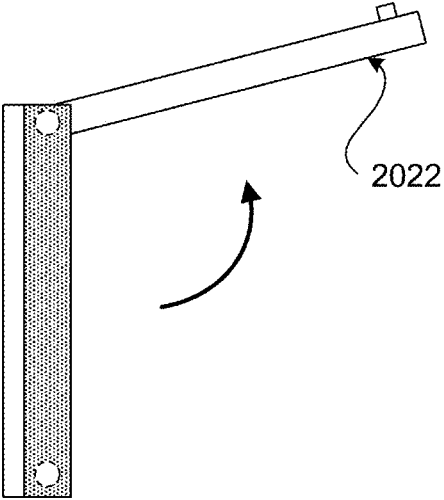

FIG. 20A

2020

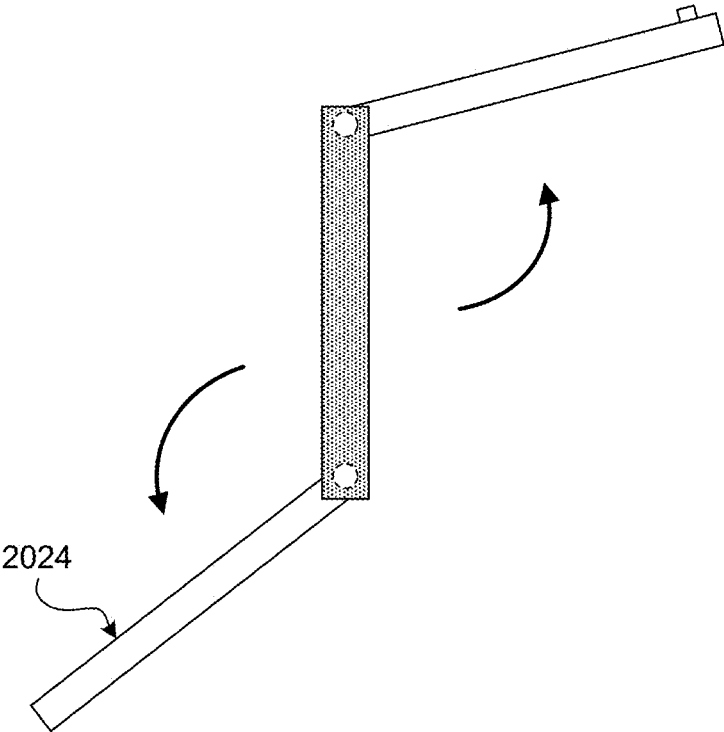

FIG. 20B

2020

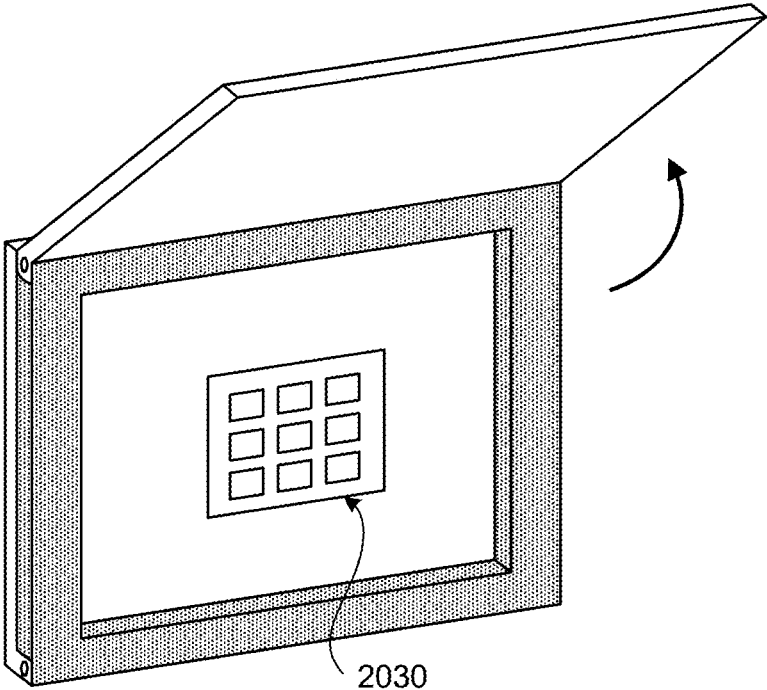

FIG. 20C

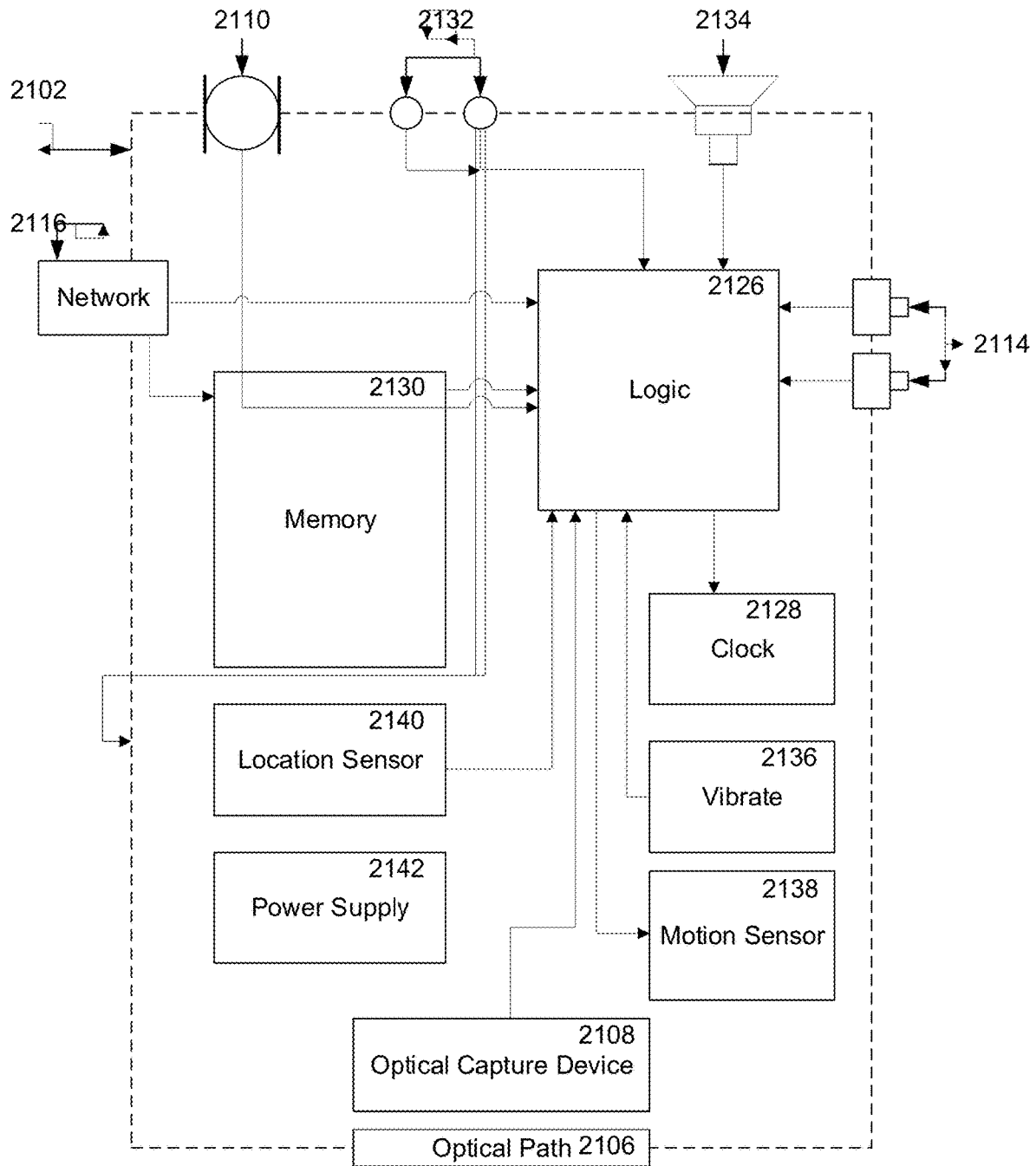

FIG. 21

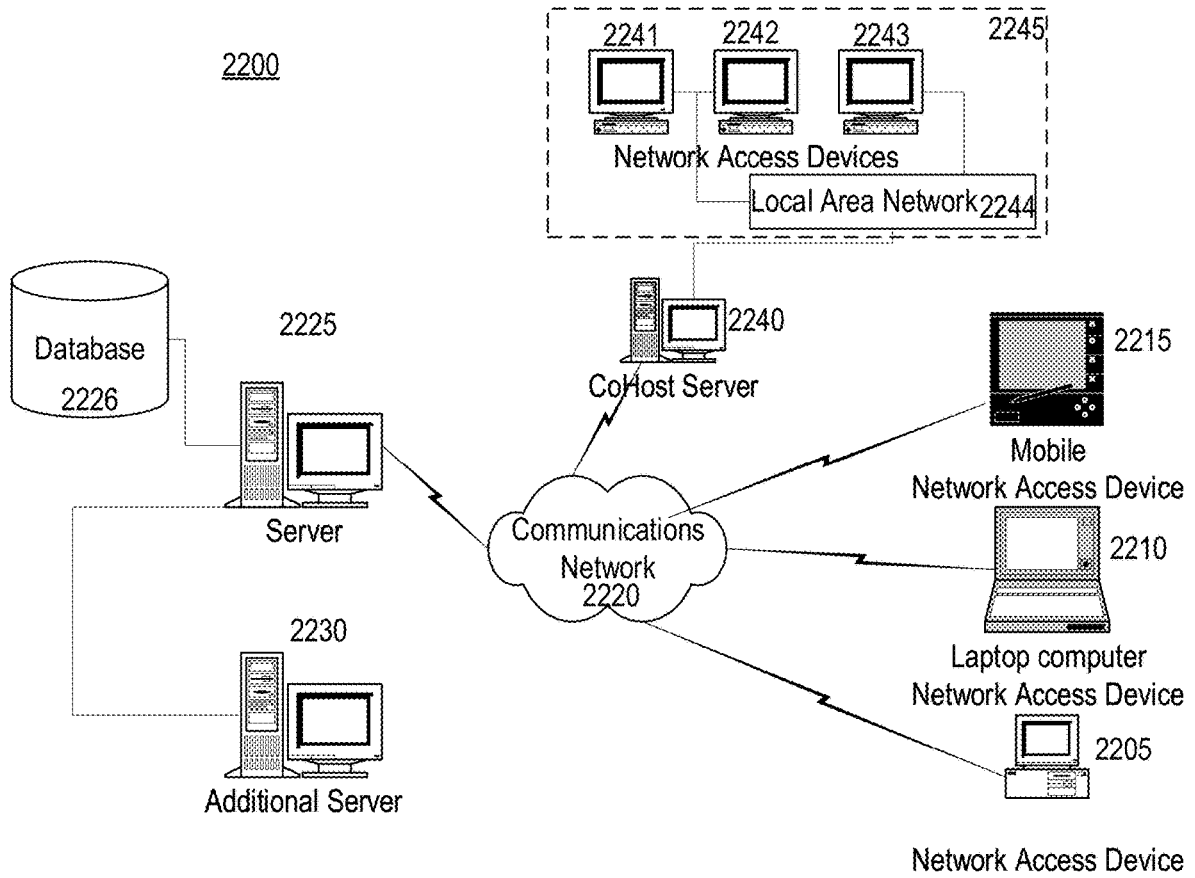

FIG. 22

METHOD AND SYSTEM FOR SECURELY RECEIVING DELIVERIES

CROSS-REFERENCE TO RELATED APPLICATION

[0001] This application is a Continuation-in-Part of and claims priority to U.S. Non-Provisional patent application Ser. No. 16/459,550, filed Jul. 1, 2019, and titled “METHOD AND SYSTEM FOR SECURELY RECEIVING DELIVERIES,” which further claimed priority to U.S. Provisional Patent Application Ser. No. 62/712,114, filed Jul. 30, 2018, and titled “METHOD AND SYSTEM FOR SECURELY RECEIVING DELIVERIES”, the entire contents of which are incorporated in this application by reference.

BACKGROUND OF THE DISCLOSURE

[0002] Before the advent of the internet, a person did most of their shopping in a brick and mortar store and brought their purchases home with them. As the convenience of internet retail grew, more people started incorporating online shopping into their daily lives. A December 2016 study revealed that 8 in 10 of U.S. consumers shop online, either through the internet or through mobile devices. Individuals can order a variety of products to their doorstep, which may include a variety of products ranging from clothing to furniture to groceries.

[0003] A byproduct of online shopping is that consumers mainly have their purchases delivered to their businesses or places of residence. These deliveries often occur when the resident is not home, which results in the package being left outside the person’s door until they get home and can take the package in. In 2017, families received an average of 27 packages per year in the US. As home delivery increased, so did package theft. 11 million homeowners had a package stolen in 2016, while 53% of homeowners worry about their packages being stolen. On average, 74% of packages are stolen during the day when homeowners are at work.

[0004] Some packages require the owner to be present for delivery, such as for a signature. While this prevents package theft, it may cause a substantial delay or inconvenience since the recipient has to be physically present to sign for the package or travel to the local post office to pick it up. This process disrupts the convenience of home delivery and discourages consumers from online shopping.

[0005] Most packages are delivered outside a home or an apartment door, sitting unattended until a resident returns home. In apartment complex hallways or home neighborhoods without surveillance, there is nothing to stop a passerby from stealing the packages. As a result, millions of homeowners experience package theft every year. Though there have been some solutions for reducing package theft, there is still a need for package recipients to control the receipt of packages without worrying about theft or pick-up.

SUMMARY OF THE DISCLOSURE

[0006] What is needed is a device that may facilitate and enables secure receipt of packages even when a recipient may not be able to personally accept the package. The present disclosure relates generally to a system and method for receiving packages through a delivery service when a person is not home. More specifically, the present disclosure

provides a system for a person to facilitate safe and secure delivery to a manually controlled module without needing to be present.

[0007] The present disclosure relates to a garage panel with integrated receiving module for receiving packages. The garage panel also includes a first garage panel configured to integrate with a garage door; a first receiving module may include: a first receiving opening for receiving packages, where the first receiving opening allows passage of packages through a first portion of the garage panel, a first receiving panel located over the first receiving opening, where the first receiving panel controls access to the first receiving opening; a first locking mechanism located on the one or both the first receiving opening or the first receiving panel, where the first locking mechanism secures the first receiving panel in a closed position when the first receiving opening is not accessible. The panel may include a first security panel located proximate to the first receiving module, where the first security panel controls the first locking mechanism.

[0008] Implementations may include one or more of the following features. The first security panel may be located on the garage door. The first security panel may be located proximate to the garage door. The first security panel may include a security panel wireless communication mechanism and the first locking mechanism may include a first locking wireless communication mechanism, where the security panel wireless communication mechanism and the first locking wireless communication mechanism are in logical communication. The second receiving opening may allow passage of packages through a second portion of the garage panel, a second receiving panel located over the second receiving opening, where the second receiving panel may control access to the second receiving opening; and a second locking mechanism located on the one or both the second receiving opening or the second receiving panel, where the second locking mechanism secures the second receiving panel in a closed position when the second receiving opening is not accessible.

[0009] The first security panel may control the second locking mechanism. Control of the first locking mechanism may be independent of control of the second locking mechanism. The second security panel may control the second locking mechanism. The first receiving module may be a different size from the second receiving module.

[0010] The first garage panel may include at least two walls, and the first receiving panel slides between the at least two walls when opened. One or more the first security panel, the first garage panel, or the first receiving module may include indicators that indicate status of the first receiving module. The first security panel may be pairable with a garage door opener that controls movement of the garage door, where the first security panel is configured to intercept prompts from the garage door opener. Intercepting may restrict movement of the garage door when the first receiving module received at least one package. Intercepting triggers a status indication of the first receiving module.

[0011] One general aspect may include an entry door with integrated receiving module for receiving packages a receiving module may include: a receiving opening for receiving packages, where the receiving opening allows passage of packages through a portion of the entry door, a receiving panel located over the receiving opening, where the receiving panel controls access to the receiving opening; a locking

mechanism located on the one or both the first receiving opening or the receiving panel, where the locking mechanism secures the receiving panel in a closed position when the receiving opening is not accessible. The door may include a security panel located proximate to the receiving module, where the security panel controls the locking mechanism. Implementations may include one or more of the following features. The entry door where the receiving module may be concealed within the entry door, limiting visibility of the receiving module. The control panel may be concealed, limiting visibility of the control panel.

[0012] One general aspect may include a receiving module for receiving packages a receiving module configured to fit into a garage door, the receiving module may include: a receiving opening for receiving packages, where the receiving opening allows passage of packages through a portion of the garage door, a receiving panel located over the receiving opening, where the receiving panel controls access to the receiving opening; a locking mechanism located on the one or both the first receiving opening or the receiving panel, where the locking mechanism secures the receiving panel in a closed position when the receiving opening is not accessible; and a security panel located proximate to the receiving module, where the security panel controls the locking mechanism. Implementations may include one or more of the following features. The receiving module may include an outer panel that conceals the receiving panel, and where the moving the outer panel allows access to the receiving panel.

BRIEF DESCRIPTION OF THE DRAWINGS

[0013] The accompanying drawings, that are incorporated in and constitute a part of this specification, illustrate several embodiments of the disclosure and, together with the description, serve to explain the principles of the disclosure:

[0014] FIG. 1 illustrates an exemplary receiving module for installation in a garage door, according to some embodiments of the present disclosure.

[0015] FIG. 2 illustrates an exemplary receiving module mounted on a garage door, according to some embodiments of the present disclosure.

[0016] FIG. 3 illustrates an exemplary receiving module attached on the underside of a mailbox.

[0017] FIG. 4 illustrates an exemplary free-standing receiving module, according to some embodiments of the present disclosure.

[0018] FIG. 5 illustrates an exemplary receiving module installed on a building front, according to some embodiments of the present disclosure.

[0019] FIG. 6A illustrates an exemplary receiving module flush with the garage door allowing for free operation of the garage door.

[0020] FIG. 6B illustrates an exemplary receiving module unfolded, wherein the unfolded receiving module may hold one or more packages.

[0021] FIG. 6C illustrates an exemplary receiving module as an enclosure wherein a package may rest inside the module.

[0022] FIG. 7A illustrates an exemplary receiving module on the garage door with a hinged receptacle, according to some embodiments of the present disclosure.

[0023] FIG. 7B illustrates an exemplary receiving module with a hinged receptacle receiving a package, according to some embodiments of the present disclosure.

[0024] FIG. 7C illustrates an exemplary receiving module with a hinged receptacle receiving a package.

[0025] FIG. 7D illustrates an exemplary receiving module with a hinged receptacle dropping a received package, according to some embodiments of the present disclosure.

[0026] FIG. 8 illustrates an exemplary receiving module communication system, according to some embodiments of the present disclosure.

[0027] FIG. 9 illustrates an exemplary receiving module with package guide, according to some embodiments of the present disclosure.

[0028] FIG. 10 illustrates an exemplary receiving module with a package platform, according to some embodiments of the present disclosure.

[0029] FIG. 11A illustrates an exemplary adaptable receiving module, according to some embodiments of the present disclosure.

[0030] FIG. 11B illustrates an exemplary adaptable receiving module, according to some embodiments of the present disclosure.

[0031] FIG. 11C illustrates an exemplary adaptable receiving module, according to some embodiments of the present disclosure.

[0032] FIG. 12A illustrates an exemplary receiving module, according to some embodiments of the present disclosure.

[0033] FIG. 12B illustrates a garage segment with an exemplary receiving module, according to some embodiments of the present disclosure.

[0034] FIG. 12C illustrates a side view of an installed exemplary receiving module, according to some embodiments of the present disclosure.

[0035] FIG. 13A illustrates an exemplary receiving module on a garage door with a wireless pet sensor detecting a pet, according to some embodiments of the present disclosure.

[0036] FIG. 13B illustrates an exemplary receiving module releasing a pet door, according to some embodiments of the present disclosure.

[0037] FIG. 13C illustrates a pet walking through an exemplary receiving module with a hinged receptacle.

[0038] FIG. 13D illustrates an exemplary receiving module with a resetting hinged receptacle, according to some embodiments of the present disclosure.

[0039] FIG. 14A illustrates an exemplary garage panel with integrated receiving module, according to some embodiments of the present disclosure.

[0040] FIG. 14B illustrates an exemplary garage panel with integrated receiving module, according to some embodiments of the present disclosure.

[0041] FIG. 15 illustrates a garage comprising an exemplary panel with integrated receiving module, according to some embodiments of the present disclosure.

[0042] FIG. 16 illustrates an exemplary door with integrated receiving module, according to some embodiments of the present disclosure.

[0043] FIG. 17A illustrates an exemplary receiving module with sliding panel, according to some embodiments of the present disclosure.

[0044] FIG. 17B illustrates an exemplary receiving module with sliding panel, according to some embodiments of the present disclosure.

[0045] FIG. 18A illustrates an exemplary receiving module with rolling panel, according to some embodiments of the present disclosure.

[0046] FIG. 18B illustrates an exemplary receiving module with rolling panel, according to some embodiments of the present disclosure.

[0047] FIG. 19 illustrates an exemplary receiving module with folding panel, according to some embodiments of the present disclosure.

[0048] FIG. 20A illustrates an exemplary receiving module with dual panels, according to some embodiments of the present disclosure.

[0049] FIG. 20B illustrates an exemplary receiving module with dual panels, according to some embodiments of the present disclosure.

[0050] FIG. 20C illustrates an exemplary receiving module with dual panels, according to some embodiments of the present disclosure.

[0051] FIG. 21 illustrates an exemplary block diagram of an exemplary embodiment of a mobile device, according to some embodiments of the present disclosure.

[0052] FIG. 22 illustrates an exemplary processing and interface system, according to some embodiments of the present disclosure.

DETAILED DESCRIPTION

[0053] The present disclosure provides generally for a system to receive deliveries. According to the present disclosure, a receiving module may allow for the secure delivery of packages without requiring the recipient to be present.

[0054] In the following sections, detailed descriptions of examples and methods of the disclosure will be given. The description of both preferred and alternative examples, though thorough, are exemplary only, and it is understood to those skilled in the art that variations, modifications, and alterations may be apparent. It is therefore to be understood that the examples do not limit the broadness of the aspects of the underlying disclosure as defined by the claims.

[0055] The present disclosure relates generally to a system and method for receiving packages through the mail when a person is not home. More specifically, the present disclosure provides a system for a person to facilitate safe and secure delivery to a receiving module without needing to be present. In some aspects, an administrator may control the module from a portable smart device or other wireless device. The receiving module may be operated digitally, manually, virtually, or combinations thereof. The settings of the receiving module may be controlled by a recipient, delivery service, sender, or combinations thereof. In some embodiments, the receiving module may be installable on a garage door.

[0056] In the following sections, detailed descriptions of examples and methods of the disclosure will be given. The description of both preferred and alternative examples, though thorough, are exemplary only, and it is understood that, to those skilled in the art, variations, modifications, and alterations may be apparent. It is therefore to be understood that the examples do not limit the broadness of the aspects of the underlying disclosure as defined by the claims.

Glossary

[0057] Receiving Module: as used herein refers to a mechanism that allows for secure delivery of packages

when a person may not be able to receive the package. May also store objects or personal items; for a personal pick-up from a friend or family member.

[0058] Package: as used herein refers to any delivery.

[0059] Expected Package: as used herein refers to an expected delivery. In some aspects, the expectation for delivery may occur when a recipient orders a product. In some embodiments, such as with a gift, the expectation for delivery may occur when the package is being delivered and the recipient grants access for that delivery.

[0060] Code (or Identification Code or Access Code): as used herein refers to any security panel input that may unlock a locking mechanism of a receiving module. In some aspects, the code may be directly input on the security panel. In some embodiments, the code may be embedded in an object, such as an identification tag or label, wherein “reading” the object may input the code. In some implementations, the reading may occur manually, such as by scanning the object. In some aspects, the reading may occur automatically, such as based on proximity of the object to the security panel.

[0061] Referring now to FIG. 1, a garage door **100** and exemplary receiving module **120** are illustrated. In some aspects, the garage door **100** may comprise removable door panels **110**. In some embodiments, the receiving module **120** may comprise a security panel **130**. In some implementations, the receiving module may also comprise a hinge-like handle to open and close the module securely. In some embodiments, the security panel **130** may comprise of a keypad containing alphanumeric characters or images.

[0062] In some aspects, the security panel **130** may be programmed with a unique code. The code may be manually changed periodically. For example, an owner may change the code prior to or after each expected delivery. In some embodiments, an owner may not expect a package, such as when a gift is sent. In some implementations, the security panel **130** may comprise contact information or a paging function, which may alert the user of an unexpected delivery. In response, a user may directly provide the delivery person with a code.

[0063] In some embodiments, a user may create a profile and connect their phone number with a universal number, which may limit exposure of personal information. In some aspects, a unique extension or phone number may be associated with a user profile or address. In some embodiments, each delivery company or distributor may be associated with an identification number that may be sent to the user, which may ensure the person requested an access code is from a legitimate source. As an illustrative example, a delivery person may text an identification number associated with the package to a phone number listed on the receiving module **120**. In some embodiments, the access code may be automatically transmitted back to the delivery person. In some aspects, the user may manually transmit the access code.

[0064] In some embodiments, a receiving module **120** may be mounted to a range of fixtures, such as a garage door, building front, or mailbox, as non-limiting examples. In some aspects, the receiving module **120** may serve as a temporary storage device. For example, a neighbor may need to borrow a hammer, and the user may not feel comfortable leaving the item out. The user may place the hammer in the receiving module **120** and give the neighbor

an access code. As another example, the receiving module 120 may temporarily store a key more securely than leaving a key under the mat.

[0065] The receiving module 120 may be connected to a different service centers for different users to be in control of each of their own individual module. In some embodiments, service centers may manage multiple receiving modules 120, wherein an individual may not be responsible for responding to each delivery. In some aspects, an individual may work with the service center to establish the parameters of the relationship, such as who sets the codes, which delivery companies are automatically acceptable, which delivery companies require permissions, and who would respond to delivery requests, as non-limiting examples.

[0066] Referring now to FIG. 2, a garage door 200 and exemplary receiving module 220 are illustrated. In some embodiments, the garage door 200 may be manufactured to include the receiving module 220. In some aspects, the garage door 200 and the receiving module 220 may be installed as a unit. In some implementations, the receiving module 220 may be offered as an optional feature of the garage door 200, wherein the feature may be selected before or after manufacture. For example, a garage door 200 may be manufactured with at least a portion of the receiving module 220, such as the receiving opening and the frame to accept a receiving panel and security panel that may be installed with the garage door 200. In some embodiments, the security panel may be installed separately and may be customizable. For example, a user may be able to select the type of security panel or at least some of the features, such as a mechanical lock, digital display, wireless capabilities, sensing capabilities, or setting options, as non-limiting examples.

[0067] In some implementations, the receiving module 220 may comprise a security display panel 230. In some aspects, the access code on the security panel 230 may be changed daily, hourly, or pertain to specific packages. In some embodiments, the receiving module 220 may comprise a camera or scanner (such as illustrated in FIG. 8), which may scan individual barcodes for delivery. In some implementations, the camera may notify a smart device when motion is detected, so that a delivery can be executed.

[0068] In some aspects, the receiving module 220 may be programmed to change the code periodically, wherein the new code may be randomly generated or the user may be prompted to change the code manually. In some embodiments, when a delivery request may be received, the receiving module 220 may prompt the user to input a new identification code specific to the delivery request. Creating single-use identification codes may reduce the chance of break in or security breach from deliberate or accidental sharing of the code. In some aspects, delivery may require a confirmation from the recipient to open the receiving module. In some implementations, the receiving module 220 may comprise a camera or scanner that could capture delivery information, such as from a label or a photo of the delivery person).

[0069] In some aspects, the identification code may only be active for a predefined length of time, which may be determined manually or automatically. For example, an expected package may have a set delivery date and time range, and the code associated with the expected package may be active during that range only. The range may be general, such as a range of days, or narrow, such as a range

of hours. Some delivery tracking systems monitor the location of the package more precisely than others, and the level of precision may partially determine a practical predefined length of time. As another example, such as where the recipient is a place of business, the code may only be active when the business is closed, otherwise, the recipient may want the delivery inside.

[0070] In some implementations, a code may unlock the locking mechanism for a limited amount of time, which may limit access after the delivery. For example, input of an identification code may unlock the receiving panel for sixty seconds, which may be enough time to insert the package but not long enough for a thief or passerby to open it unnoticed after the delivery. In some aspects, a secondary alert system may notify a recipient if the receiving panel is open for an extended amount of time, which may indicate an unauthorized person is attempting to access the package or anything beyond the receiving opening. As an illustrative example, the secondary alert system may beep to warn a deliverer that the time to open, close, or both the receiving panel is closing, and the recipient may be notified if the receiving panel is still open after that predefined time. In some aspects, the code may unlock the locking mechanism once, wherein once the receiving panel is closed after an initial opening, the code no longer works. In some embodiments, a deliverer may manually request a refreshed or new code if the original code expires or they accidentally close the door before inserting the expected package.

[0071] Referring now to FIG. 3, a mailbox 310 with an exemplary receiving module 320 is illustrated. In some aspects, the receiving module 320 may be tailored to the size of a mailbox, and the security panel 330 may be scaled accordingly. In some implementations, the security panel 330 may be mechanical, wherein a power source may not be required, which may be convenient where the receiving module 320 may be mounted to a fixture detached from the building.

[0072] In some implementations, the receiving module 320 may be mounted on the underside of the mailbox. In some embodiments, the security panel 330 may comprise a detachable mechanism for removal. In some aspects, a detachable mechanism may allow for recharging of the receiving module 320. In some implementations, the security panel 330 may be rechargeable and the receiving module 320 may comprise a solar power collector, which may charge the security panel 330.

[0073] Referring now to FIG. 4, an exemplary independent receiving module 420 is illustrated. In some embodiments, the receiving module 420 may be free standing, wherein the receiving module 420 may not be mounted to a fixture. In some implementations, a free-standing receiving module 420 may be portable, which may allow the user to place it wherever may be convenient. For example, a user may periodically change their landscape or seasonal décor and being able to move the receiving module 420 may allow for more flexibility.

[0074] In some aspects, the security panel 430 may be located on, but not limited to, the front side of the receiving module 430, such as topside, left or right side, as non-limiting examples. In some implementations, the receiving module 420 may comprise separate compartments to receive different deliveries of different sizes. In some embodiments,

the code on this security panel **430** may have different codes for each compartment, wherein each code may unlock only the individual compartment.

[0075] In some embodiments, the receiving module may comprise a portability mechanism **440** on the underside. In some aspects, the portability mechanism may comprise wheels, tracks, or any other form of transportation, as non-limiting examples. In some implementations, the portability mechanism **440** may comprise a locking system, wherein the receiving module **420** may be stable on slippery surfaces or slopes. In some embodiments, the receiving module **420** may be controlled manually from a portable smart device for transportation using the portability mechanism **440**. In some aspects, the receiving module **420** may be free standing in a specific location.

[0076] In some embodiments, at least a portion of the receiving module **420** may comprise a refrigerated compartment, which may allow for the temporary storage of perishables. For example, meal services that deliver perishable ingredients or fully cooked meals may require refrigeration. Often, the perishables are shipped with dry ice, which may keep the package cool for a limited time. If the recipient arrives home late or even the next day, the perishables may spoil. Delivery into a refrigerated compartment may allow for longer safe storage.

[0077] Referring now to FIG. 5, an exemplary building front **510** with receiving module **520** is illustrated. In some embodiments, the receiving module **520** may comprise or may be located on an entry door **550**, such as an exterior door and an interior door, wherein the exterior door may comprise a security panel. In some implementations, the interior door may provide access to the receiving module **520**. In some aspects, the receiving module **520** may be used residentially or commercially.

[0078] In some embodiments, an interior door may comprise a secondary security panel, which may limit access to those who may have permission to retrieve deliveries. In some aspects, a receiving module **520** may be programmed to be unlocked at certain hours. In some implementations, the receiving module **520** may be installed into the building based on specifications.

[0079] Referring now to FIGS. 6A-6C, exemplary unfolding steps of a collapsible receptacle **650** of a receiving module **620** are illustrated. In some aspects, the receiving module **620** may hinder the ability of the garage door **600** to go up when the collapsible receptacle **650** is unfolded. In some embodiments, the collapsible receptacle **650** may automatically unfold to hold the package when a security code is typed in. In some implementations, the collapsible receptacle **650** may be manually unfolded when a package is placed in the receiving module **620**. In some aspects, the collapsible receptacle **650** may hold up to a certain weight limit. In some embodiments, the collapsible receptacle **650** may inhibit a delivery person from reaching into the receiving module **620**. In some aspects, the collapsible receptacle **650** may be manually unlocked or unfolded by the recipient when they may expect a package.

[0080] Referring now to FIGS. 7A-7D, exemplary steps for delivering a package **760** through a receiving module **720** are illustrated. In some embodiments, a hinged receptacle **750** may allow the package to slide off the receiving module **720** more delicately than a normal drop, which may be particularly useful for breakable contents. In some aspects, the hinged receptacle **750** may rehing after a delivery has

been accepted, allowing the garage door **700** to open safely without damaging the delivery.

[0081] In some implementations, the hinged receptacle **750** may be controlled manually from a smart device. In some aspects, the hinged receptacle **750** may retain the package, which may be beneficial for fragile contents. In some embodiments, the hinged receptacle **750** may automatically remain engaged if a package meets certain threshold parameters, such as weight or size. In some implementations, the hinged receptacle **750** may remain engaged where the delivery person may indicate that the package is stamped fragile. In some aspects, the hinged receptacle **750** may remain engaged where the user may request it. In some embodiments, the hinged receptacle **750** may swivel from outside to inside, which may inhibit intruders from entering the garage and prevent unauthorized access to the delivered packages. The hinged receptacle **750** may remain in a locked position until the recipient is notified of a delivery or a code is typed into a security panel.

[0082] Referring now to FIG. 8, exemplary steps for delivering and receiving an expected package **860** through a receiving module **820**. In some aspects, a camera or scanner **835** in logical communication with the security panel **830** may be used to verify a delivery by scanning a label or barcode **865** associated with a package. In some embodiments, the camera or scanner **835** may also detect motion and let the recipient know when there is a delivery or such movement in front of the receiving module **820**. In some implementations, the receiving module **820** may be paired with a computing device **880** of the recipients' choice, such as a smartphone, tablet, or laptop.

[0083] In some aspects, a notification may be received **882** by the recipient. As non-limiting examples, the notifications may indicate a movement near the receiving module **820**, package delivery, or a security threat. In some embodiments, the recipient may allow or deny the delivery of a package **884** using their computing device **880**. In some aspects, the delivery prompt may include a photograph of the delivery person as an added security measure.

[0084] The module may lock and unlock manually from the users' phone, or in person, and may as well be unlocked at the discretion of the user based on the camera/scanner **835**. The camera/scanner **835** may also have the ability to scan barcodes of a package. The module may be programmed to recognize each individual package before the package arrive. In some embodiments, where a user may be ordering an item for delivery to their own place, the user may input a delivery code for the delivery company, wherein the code may be printed on the package label or embedded in the SKU. In some implementations, where the code may be embedded in the SKU, scanning the SKU may automatically input the code and unlock the receiving module **820**.

[0085] In some aspects, the receiving module **820** may pair with authorized portable devices within a predefined range. For example, official portable devices associated with delivery companies may be authorized to receive access codes. In some embodiments, the receiving module **820** may indicate to the recipient that a package has been delivered. For example, the receiving module **820** may comprise lighting that may be a predefined color or intensity based on its status, such as empty, delivery on ground, or delivery on hinged receptacle. In some embodiments, the notifications may be programmable. In some implementations, the receiving module **820** may transmit a reminder notification to a

portable device associated with the user's profile when the portable device is detected within a predefined range.

[0086] Referring now to FIG. 9, an exemplary receiving module 920 with package guide 925 is illustrated. In some aspects, a delivery may be inserted through the receiving module 920 and then slide down the package guide 925, which may reduce the impact of dropping to the ground. In some embodiments, the package guide 925 may be inserted by the recipient for delicate packages.

[0087] In some implementations, the package guide 925 may be removed or collapsed manually to ensure that the garage door 900 may resume normal use. In some embodiments, the package guide 925 may collapse or spring back into a folded position once a package has been placed. In some aspects, the package guide 925 may latch to the receiving module to ensure support.

[0088] Referring now to FIG. 10, a garage door 1000 with an exemplary receiving module 1020 with package platform 1025 is illustrated, wherein the package platform 1025 may reduce damage from dropping a package through the receiving module 1020. In some aspects, a package platform 1035 may ensure that when a package is received through the receiving module 1020 the package may drop onto a package platform 1025, which may brace the fall of the delivery. In some embodiments, the package platform 1025 may comprise a protective material to ensure the safety of the delivery, such as soft cloth padding, gel padding, rubber padding, or combinations thereof, as non-limiting examples.

[0089] In some aspects, the package platform 1025 may be integrated into the garage floor, which may be less obtrusive to the path. In some implementations, the package platform 1025 may be removed manually when not in use. In some aspects, the package platform 1025 may be paired with a package guide, such as illustrate in FIG. 9, which may provide extra assurance that that the delivery will not be damaged or damage the area proximate to the delivery.

[0090] In some embodiments, the receiving module may allow for a mail carrier to deliver a package(s) to a user that may not be present at the time. This may save the user time from taking a separate trip to the destination of their package (s) if they were not present in any other scenario. In some aspects, the receiving module may hold multiple packages depending on the configuration of the receiving module. For example, where the receiving module may hold the package, the number and size of the delivery may be limited to the size of the receiving module. Wherein the receiving module drops the package to the ground, the number and size of the delivery may be more varied.

[0091] Referring now to FIGS. 11A-11C, an exemplary adaptable receiving module 1120 with variable delivery ports is illustrated, wherein the delivery ports may limit access based on a package size. In some embodiments, an adaptable receiving module 1120 may will allow for the secure delivery of different sized packages (small package 1160, medium package 1170, or larger package 1180). In some aspects, the garage door 1100 may compromise tiered delivery access.

[0092] In some implementations, a small slot located on the adaptable receiving module 1120 may receive a small package 1160 or secure mail, such as certified letters. In some embodiments, a medium size package slot may receive a medium package 1170. In some embodiments, adaptable receiving module 1120 may comprise a large package door for a large package 1180. In some aspects, the adaptable

receiving module 1120 may consist of shelving place holders to store a delivery in its own compartment. For example, a shelf may separate the small package 1160 in its own space. In some implementations, the adaptable receiving module 1120 may provide different compartments to separate multiple deliveries at once, and the shelves on the interior of the adaptable receiving unit 1120 may be manually or automatically removed to store a large package 1180.

[0093] Referring now to FIG. 12A, an exemplary receiving module 1200 is illustrated. In some aspects, the receiving module 1200 may comprise a bottom hinge, which may allow the door to pull down. In some embodiments, the receiving module 1200 may comprise a number security panel, which may comprise a digital or mechanical input system.

[0094] Referring now to FIG. 12B, a segment of a garage door 1240 with an exemplary receiving module 1200 is illustrated. In some implementations, the receiving module 1200 may replace a panel within a garage door 1240. In some embodiments, the receiving module 1200 may be pre-installed within the garage door 1240, wherein installation of the garage door 1240 may include the receiving module 1200. In some aspects, the receiving module 1200 may be integrated into the garage door 1240 post manufacture, such as by removing a panel from the garage door 1240.

[0095] In some implementations, the receiving module 1200 may comprise a similar façade as those of the surrounding panels, which may allow the receiving module 1200 to blend in. The material may comprise a durable material, which may allow the receiving module 1200 to withstand the elements. In some aspects, the door of the receiving module 1200 may be customizable depending on the dimensions and location of the receiving module 1200 within garage door 1240. In some embodiments, the door may be sliding, and the door may click into an open position to allow for easy delivery. In some implementations, the receiving module 1200 may comprise a sensor that may detect once a package has been delivered and automatically close the door to prevent access to the package.

[0096] Referring now to FIG. 12C, a side view of an installed exemplary receiving module 1200 is illustrated. In some embodiments, the receiving module 1200 may comprise a lever locking mechanism, which may release when the correct code is entered into the security panel. In some aspects, a portion of the receiving module 1200 may be directly connected to the garage door. In some implementations, the receiving module 1200 may be self-contained, which may allow a receiving module 1200 to be inserted into the garage door or other appropriate opening.

[0097] Referring now to FIGS. 13A-13D, exemplary steps for a pet 1330 activating a receiving module 1320 are illustrated. In some aspects, the receiving module 1320 may comprise a security panel with a sensor mechanism, such as RFID, IR, NFC, or other sensing technology. In some embodiments, the sensor mechanism may be in logical communication with a processor that may receive programming instructions either directly through the security panel or wirelessly from external devices. In some implementations, the programming instructions may identify unique identification numbers (UIN) or codes associated with tags on expected packages and permissible pets.

[0098] In some aspects, the UIN for each expected package may be uploaded in anticipation of receipt, such as by

a sender, a delivery company, or the recipient. In some implementations, the UIN permission may be temporary, such as within two days of the expected delivery, before, after, or both. In some aspects, the UIN permission may be confirmed by the recipient to limit fraudulent upload of UINs. In some embodiments, the tag may be embedded in the package, such as on a label, in the walls of the box, or on an inner object. For pets, the tags may be embedded on a collar or embedded into their skin.

[0099] Where the receiving module 1320 may allow for passage of a pet 1330, the receiving module 1320 may be installed close to floor level to allow a pet 1330 to step through. In some embodiments, the receiving module 1320 may be installed on a garage, exterior wall, or exterior door, as non-limiting examples, wherein a pet 1330 may pass through a receiving opening and enter an interior portion of a building. In some implementations, such as illustrated in FIG. 13A, a sensor on a security panel 1340 of a receiving module 1320 may detect a tag 1335 of a pet 1330 within a predefined proximity. At FIG. 13B, a front panel 1345 of the receiving module 1320 may release and drop down allowing the pet 1330 to enter into a receiving opening.

[0100] At FIG. 13C, to limit access to anyone other than the pet 1330, the pet 1330 may push down a back panel 1350 as the pet 1330 walks through the receiving opening into the interior, wherein pushing down the back panel 1350 may mechanically pull up or trigger the front panel 1345 to close. As FIG. 13D, once the pet 1330 walks through the receiving opening, the back panel 1350 may close. In some implementations, having two separate panels may increase the security of the receiving module 1320. In some aspects, the panels may operate differently for an expected package than a pet 1330. In some embodiments, with an expected package, the delivery person may need to take specific actions to operate the receiving module 1320, such as manually open the front panel 1345, open a separate delivery panel, or input credentials or additional codes, as non-limiting examples.

[0101] In some implementations, the receiving module 1320 may comprise two sets of panels, wherein operation of one set may be triggered by a pet 1330 and the operation of the second set may be triggered by an expected package. Separate operating systems may allow for each system to be configured to each set of security needs. For example, different safety mechanisms may need to be in place for a pet 1330 than for the package. In some aspects, a confirmation mechanism may allow for secondary security. For example, detection of a pet 1330 with a tag 1335 may prompt transmission of a pet entry confirmation to the recipient or resident of the home. The secondary confirmation may allow the pet owner to confirm that no one is nearby or manipulating the pet 1330 to gain access.

[0102] Referring now to FIG. 14A, an exemplary garage panel 1400 with integrated receiving module 1420 is illustrated. Referring now to FIG. 14B, an exemplary garage panel 1400 with integrated receiving module 1420 is illustrated. In some aspects, a receiving module 1420 may be integrated into a garage panel 1400, such as during manufacture. This may allow a manufacture to design the receiving module 1420 to be fully supported by the garage design.

[0103] In some embodiments, a post manufacture addition of a receiving module may cause strain on the garage system. For example, if the weight of a post manufacture version is not properly balanced, the motor and tracks may be affected and damaged over time. Where the post manu-

facture version requires cutting into the surface of a garage, the integrity of the panels, which may limit the effectiveness of keeping the garage sealed. It may create an additional point that risks deterioration over time.

[0104] In some implementations, a garage may comprise multiple garage panels 1400, and the number of garage panels 1400 with receiving modules 1420 may be customizable. In some aspects, a receiving module 1420 may comprise a sliding panel with handle 1415 that may slide into a pocket of the garage panel 1400. The sliding panel may overlap with other portions of the garage panel 1400. For example, the garage panel 1400 may comprise a double-walled design with false sub panels. The sliding panel may fit into and slide within the double walls.

[0105] In some embodiments, a security panel 1430 may be located separate from the receiving module 1420 on the garage panel 1400. The security panel 1430 may be located at a different location, such as another location on the garage panel 1400, on another panel, or separate from the garage. In some aspects, the security panel 1430 may be remote and wirelessly control the receiving module 1420. A separate location may make the receiving module 1420 less obvious, which may deter tampering with the receiving module 1420. Where the receiving module 1420 and the security panel 1430 may be integrated with the garage panel 1400, the security panel 1430 may be wired through the garage panel 1400 to the receiving module 1420.

[0106] Referring now to FIG. 15, a garage 1500 comprising an exemplary garage panel 1502 with integrated receiving modules 1520, 1522, 1524 is illustrated. In some aspects, a garage 1500 may comprise a garage panel 1502 with multiple receiving modules 1520, 1522, 1524, such as for different size packages. In some embodiments, the receiving modules 1520, 1522, 1524 may be controlled by separate or a single security panel 1530. In some aspects, a security panel 1530 may be located proximate to the garage 1500, such as on an exterior wall of a building. The security panel 1530 may be integrated into an opening control panel that opens or closes the garage 1500 when a security code is correctly input. In some aspects, one or both a locking mechanism may comprise a locking wireless communication mechanism and a security panel may comprise a security panel wireless communication mechanism. This may allow for wireless communication between one or more the security panel 1530, the locking mechanism, the garage door 1500, and a garage door opener.

[0107] In some implementations, each receiving module 1520, 1522, 1524 may be controlled independently, which may allow for secure delivery based on predefined parameters. For example, multiple sizes may allow for limited access of each receiving module 1520, 1522, 1524 based on package size or security level. For example, the largest receiving module 1522 may only be accessed when a package exceeds a specific size or is pre-approved by the sender or recipient. When ordered, packages may be identified by size, so that a recipient may know what to expect. This may prevent a request for the largest receiving module 1522 to deliver an envelope.

[0108] In some aspects, placement of the receiving modules 1520, 1522, 1524 on the garage panel 1500 may be customizable or based on predefined parameters. For example, the smallest receiving module 1520 may be located on the side of the garage panel 1502, which may allow deliver of small packages that may not interfere with

the space that a vehicle would occupy in the garage. The specific parameters may be customizable, such as through calibration or input of settings, which may occur on site of the garage panel 1502 or may occur remotely, such as through a garage door opener, smartphone, or through an online portal.

[0109] In some embodiments, the garage panel 1502 may comprise indicators that may notify a user that a predefined action occurred, such as a delivery has occurred, access without delivery, or error, as non-limiting examples. The indicator may specifically identify which receiving module 1520, 1522, 1524 may have been accessed. In some implementations, receiving modules 1520, 1522, 1524 may comprise multiple security panels 1530, which may allow for independent and targeted control of separate receiving modules 1520, 1522, 1524.

[0110] In some embodiments, one or more of a security panel 1530 and receiving module 1520, 1522, 1524 may pair with a garage door opener. In some aspects, a delivery may intercept a communication between a garage door opener and a garage door 1500. One or more of the security panel 1530 and the receiving module 1520, 1522, 1524 may interfere with a vehicle attempting to enter or exit the garage. The garage panel 1502 may indicate or alert the user of the potential issue. In some implementations, the garage door 1500 may not open remotely when a potentially interfering package is received. It may require a second overriding command, which may be on site or remote. Requiring a user to step out of the vehicle may limit the risk of accidental override. In some embodiments, an indicator may be triggered when a garage door opener prompts opening, which may limit security risk of constantly indicating the presence of a package.

[0111] Referring now to FIG. 16, an exemplary entry door 1600 with integrated receiving module 1620 is illustrated. An entry door 1600 may be installed within a door frame that allows for control of passage through a threshold. In some embodiments, an entry door 1600 may comprise a receiving module 1620 that may be built in the body of the entry door 1600. In some aspects, the receiving module 1620 may be integrated during manufacture, which may allow for a more secure attachment of a receiving module 1620 than one that requires cutting into an existing door. In some embodiments, a security panel 1630 may be located behind a secondary panel, which may look like a typical door panel. Opening the secondary panel may provide access to the security panel 1630.

[0112] As an illustrative example, a door 1600 with integrated receiving module 1620 may be useful in apartments within an apartment complex, where thefts of packages left outside the door are prevalent. Integrating the receiving module 1620 may allow for a standardized appearance and increased security. In some embodiments, one or both the receiving module 1620 and the security panel 1630 may be controlled wirelessly, such as by the resident or by an authorized representative from the apartment complex.

[0113] Referring now to FIG. 17A, an exemplary receiving module 1720 with sliding panel 1722 is illustrated. Referring now to FIG. 17B, an exemplary receiving module 1720 with sliding panel 1722 is illustrated. In some embodiments, a sliding panel 1722 may be slid over, under, or within a proximate area or surface. In some aspects, a sliding panel 1722 may comprise a pocket door that may be slid into a recess of a proximate area, such as where the receiving

module 1720 is integrated into the garage door or door. A pocket door may be effective where the receiving module 1720 comprises sufficient area for the sliding panel 1722 in both the open and closed position.

[0114] In some implementations, a sliding panel 1722 may slide over or under a proximate area, which may allow for a post-manufacture version. Sliding over or under may allow for a thinner surrounding area. For example, an effective garage door may comprise a weight limit, and a thinner garage door may alleviate the added weight of integrating a receiving module 1720.

[0115] Referring now to FIG. 18A, an exemplary receiving module 1820 with rolling panel 1822 is illustrated. Referring now to FIG. 18B, an exemplary receiving module 1820 with rolling panel 1822 is illustrated. In some embodiments, a rolling panel 1822 may comprise a series of segments that may allow separation of panels to rotate over a spool. In some aspects, a rolling panel 1822 may comprise a flexible material that may allow the rolling panel 1822 to wrap around a spool. In some implementations, the spool may comprise a motor that may control the spooling. In some embodiments, control of the spool may be remote, such as through the garage door and garage motor system.

[0116] Referring now to FIG. 19, an exemplary receiving module 1920 with folding panel 1922 is illustrated. In some aspects, a receiving module 1920 may comprise a hinged folding panel 1922. In some implementations, a receiving module 1920 may comprise a sensor that may detect when a package 1960 may be received. Detection of actual delivery may allow a user to know whether someone accessed or attempted to access the receiving module 1920 without actually delivering a package 1960.

[0117] Referring now to FIG. 20A, an exemplary receiving module 2020 with dual panels 2022, 2024 is illustrated. Referring now to FIG. 20B, an exemplary receiving module with dual panels 2022, 2024 is illustrated. Referring now to FIG. 20C, an exemplary receiving module 2020 with dual panels 2022, 2024 is illustrated.

[0118] In some aspects, dual panels 2022, 2024 may allow for added levels of security. For example, an outer panel 2022 may obscure an inner panel 2024 that may include the security panel 2030. The outer panel 2022 may look like a typical or standard garage door panel, which may limit risk of non-delivery persons from noticing the receiving module 2020. In some aspects, one or both the receiving module 2020 and the security panel 2030 may comprise a concealing panel that may limit visibility of one or more the receiving module 2020, the security panel 2030, and the status of the receiving module 2020.

[0119] In some aspects, the dual panels 2022, 2024 may open differently, such as different directions or different panel types, as non-limiting examples. In some embodiments, the inner panel 2024 may provide a guide for a package, such as illustrated and described in FIGS. 7A-7D. Requiring combined manipulation of the dual panels 2022, 2024 may limit risk of tampering. In some implementations, authorized access of one or both of the dual panels 2022, 2024 may activate an automatic opening that may remain open based on predefined parameters, such as package size, detection of package receipt, or a set duration, as non-limiting examples.

[0120] Referring now to FIG. 21, an exemplary block diagram of an exemplary embodiment of a mobile device 2102 is illustrated. The mobile device 2102 may comprise an

optical capture device **2108**, which may capture an image and convert it to machine-compatible data, and an optical path **2106**, typically a lens, an aperture, or an image conduit to convey the image from the rendered document to the optical capture device **2108**. The optical capture device **2108** may incorporate a Charge-Coupled Device (CCD), a Complementary Metal Oxide Semiconductor (CMOS) imaging device, or an optical sensor of another type.

[0121] In some embodiments, the mobile device **2102** may comprise a microphone **2110**, wherein the microphone **2110** and associated circuitry may convert the sound of the environment, including spoken words, into machine-compatible signals. Input facilities **2114** may exist in the form of buttons, scroll-wheels, or other tactile sensors such as touchpads. In some embodiments, input facilities **2114** may include a touchscreen display. Visual feedback **2132** to the user may occur through a visual display, touchscreen display, or indicator lights. Audible feedback **2134** may be transmitted through a loudspeaker or other audio transducer. Tactile feedback may be provided through a vibration module **2136**.

[0122] In some aspects, the mobile device **2102** may comprise a motion sensor **2138**, wherein the motion sensor **2138** and associated circuitry may convert the motion of the mobile device **2102** into machine-compatible signals. For example, the motion sensor **2138** may comprise an accelerometer, which may be used to sense measurable physical acceleration, orientation, vibration, and other movements. In some embodiments, the motion sensor **2138** may comprise a gyroscope or other device to sense different motions.

[0123] In some implementations, the mobile device **2102** may comprise a location sensor **2140**, wherein the location sensor **2140** and associated circuitry may be used to determine the location of the device. The location sensor **2140** may detect Global Position System (GPS) radio signals from satellites or may also use assisted GPS where the mobile device may use a cellular network to decrease the time necessary to determine location. In some embodiments, the location sensor **2140** may use radio waves to determine the distance from known radio sources such as cellular towers to determine the location of the mobile device **2102**. In some embodiments these radio signals may be used in addition to and/or in conjunction with GPS.

[0124] In some aspects, the mobile device **2102** may comprise a logic module **2126**, which may place the components of the mobile device **2102** into electrical and logical communication. The electrical and logical communication may allow the components to interact. Accordingly, in some embodiments, the received signals from the components may be processed into different formats and/or interpretations to allow for the logical communication. The logic module **2126** may be operable to read and write data and program instructions stored in associated storage **2130**, such as RAM, ROM, flash, or other suitable memory. In some aspects, the logic module **2126** may read a time signal from the clock unit **2128**. In some embodiments, the mobile device **2102** may comprise an on-board power supply **2142**. In some embodiments, the mobile device **2102** may be powered from a tethered connection to another device, such as a Universal Serial Bus (USB) connection.

[0125] In some implementations, the mobile device **2102** may comprise a network interface **2116**, which may allow the mobile device **2102** to communicate and/or receive data to a network and/or an associated computing device. The

network interface **2116** may provide two-way data communication. For example, the network interface **2116** may operate according to an internet protocol. As another example, the network interface **2116** may comprise a local area network (LAN) card, which may allow a data communication connection to a compatible LAN. As another example, the network interface **2116** may comprise a cellular antenna and associated circuitry, which may allow the mobile device to communicate over standard wireless data communication networks. In some implementations, the network interface **2116** may comprise a Universal Serial Bus (USB) to supply power or transmit data. In some embodiments, other wireless links known to those skilled in the art may also be implemented.

[0126] Referring now to FIG. 22, an exemplary processing and interface system **2200** is illustrated. In some aspects, access devices **2215**, **2210**, **2205**, such as a paired portable device **2215** or laptop computer **2210** may be able to communicate with an external server **2225** through a communications network **2220**. The external server **2225** may be in logical communication with a database **2226**, which may comprise data related to identification information and associated profile information. In some embodiments, the server **2225** may be in logical communication with an additional server **2230**, which may comprise supplemental processing capabilities.

[0127] In some aspects, the server **2225** and access devices **2205**, **2210**, **2215** may be able to communicate with a cohost server **2240** through a communications network **2220**. The cohost server **2240** may be in logical communication with an internal network **2245** comprising network access devices **2241**, **2242**, **2243** and a local area network **2244**. For example, the cohost server **2240** may comprise a payment service, such as PayPal or a social network, such as Facebook or a dating website.

CONCLUSION

[0128] A number of embodiments of the present disclosure have been described. While this specification contains many specific implementation details, there should not be construed as limitations on the scope of any disclosures or of what may be claimed, but rather as descriptions of features specific to particular embodiments of the present disclosure.

[0129] Certain features that are described in this specification in the context of separate embodiments can also be implemented in combination or in a single embodiment. Conversely, various features that are described in the context of a single embodiment can also be implemented in combination in multiple embodiments separately or in any suitable sub-combination. Moreover, although features may be described above as acting in certain combinations and even initially claimed as such, one or more features from a claimed combination can in some cases be excised from the combination, and the claimed combination may be directed to a sub-combination or variation of a sub-combination.

[0130] Similarly, while operations are depicted in the drawings in a particular order, this should not be understood as requiring that such operations be performed in the particular order shown or in sequential order, or that all illustrated operations be performed, to achieve desirable results. In certain circumstances, multitasking and parallel processing may be advantageous.

[0131] Moreover, the separation of various system components in the embodiments described above should not be

understood as requiring such separation in all embodiments, and it should be understood that the described program components and systems can generally be integrated together in a single software product or packaged into multiple software products.

[0132] Thus, particular embodiments of the subject matter have been described. Other embodiments are within the scope of the following claims. In some cases, the actions recited in the claims can be performed in a different order and still achieve desirable results. In addition, the processes depicted in the accompanying figures do not necessarily require the particular order show, or sequential order, to achieve desirable results. In certain implementations, multitasking and parallel processing may be advantageous. Nevertheless, it will be understood that various modifications may be made without departing from the spirit and scope of the claimed disclosure.

What is claimed is:

1. A garage panel with integrated receiving module for receiving packages, the garage panel comprising:

a first garage panel configured to integrate with a garage door;

a first receiving module comprising:

a first receiving opening for receiving packages, wherein the first receiving opening allows passage of packages through a first portion of the garage panel, a first receiving panel located over the first receiving opening, wherein the first receiving panel controls access to the first receiving opening;

a first locking mechanism located on the one or both the first receiving opening or the first receiving panel, wherein the first locking mechanism secures the first receiving panel in a closed position when the first receiving opening is not accessible; and

a first security panel located proximate to the first receiving module, wherein the first security panel controls the first locking mechanism.

2. The garage panel of claim 1, wherein the first security panel is located on the garage door.

3. The garage panel of claim 1, wherein the first security panel is located proximate to the garage door.

4. The garage panel of claim 3, wherein the first security panel comprises a security panel wireless communication mechanism and the first locking mechanism comprises a first locking wireless communication mechanism, wherein the security panel wireless communication mechanism and the first locking wireless communication mechanism are in logical communication.

5. The garage panel of claim 1, further comprising:

a second receiving module comprising:

a second receiving opening for receiving packages, wherein the second receiving opening allows passage of packages through a second portion of the garage panel,

a second receiving panel located over the second receiving opening, wherein the second receiving panel controls access to the second receiving opening; and

a second locking mechanism located on the one or both the second receiving opening or the second receiving panel, wherein the second locking mechanism secures the second receiving panel in a closed position when the second receiving opening is not accessible.

6. The garage panel of claim 5, wherein the first security panel controls the second locking mechanism.

7. The garage panel of claim 5, wherein control of the first locking mechanism is independent of control of the second locking mechanism.

8. The garage panel of claim 5, further comprising a second security panel located proximate to the second receiving module, wherein the second security panel controls the second locking mechanism.

9. The garage panel of claim 5, wherein the first receiving module is a different size from the second receiving module.

10. The garage panel of claim 1, wherein the first garage panel comprises at least two walls, and the first receiving panel slides between the at least two walls when opened.

11. The garage panel of claim 1, wherein one or more the first security panel, the first garage panel, or the first receiving module comprise indicators that indicate status of the first receiving module.

12. The garage panel of claim 1, wherein the first security panel is pairable with a garage door opener that controls movement of the garage door, wherein the first security panel is configured to intercept prompts from the garage door opener.

13. The garage panel of claim 12, wherein intercepting restricts movement of the garage door when the first receiving module received at least one package.

14. The garage panel of claim 12, wherein intercepting triggers a status indication of the first receiving module.

15. An entry door with integrated receiving module for receiving packages, the entry door comprising:

a receiving module comprising:

a receiving opening for receiving packages, wherein the receiving opening allows passage of packages through a portion of the entry door,

a receiving panel located over the receiving opening, wherein the receiving panel controls access to the receiving opening;

a locking mechanism located on the one or both the first receiving opening or the receiving panel, wherein the locking mechanism secures the receiving panel in a closed position when the receiving opening is not accessible; and

a security panel located proximate to the receiving module, wherein the security panel controls the locking mechanism.

16. The entry door of claim 15, wherein the receiving module is concealed within the entry door, limiting visibility of the receiving module.

17. The entry door of claim 15, wherein the control panel is concealed, limiting visibility of the control panel.

18. A receiving module for receiving packages, the receiving module comprising:

a receiving module configured to fit into a garage door, the receiving module comprising:

a receiving opening for receiving packages, wherein the receiving opening allows passage of packages through a portion of the garage door,

a receiving panel located over the receiving opening, wherein the receiving panel controls access to the receiving opening;

a locking mechanism located on the one or both the first receiving opening or the receiving panel, wherein the

locking mechanism secures the receiving panel in a closed position when the receiving opening is not accessible; and

a security panel located proximate to the receiving module, wherein the security panel controls the locking mechanism.

19. The receiving module of claim **18**, wherein the receiving module comprises an outer panel that conceals the receiving panel, and wherein the moving the outer panel allows access to the receiving panel.

20. The receiving module of claim **19**, wherein the locking mechanism secures the outer panel in a closed position when the receiving opening is not accessible.

* * * * *