



US 20140353958A1

(19) **United States**

(12) **Patent Application Publication**
HUNKELER et al.

(10) **Pub. No.: US 2014/0353958 A1**

(43) **Pub. Date: Dec. 4, 2014**

(54) **METHOD OF, AND APPARATUS FOR, PRODUCING MULTI-LEAF, FOLDED PRINTED PRODUCTS, IN PARTICULAR PERIODICALS AND BROCHURES**

Publication Classification

(51) **Int. Cl.**
B42D 5/00 (2006.01)
B65H 45/04 (2006.01)
B41F 17/02 (2006.01)
(52) **U.S. Cl.**
CPC . *B42D 5/00* (2013.01); *B41F 17/02* (2013.01);
B65H 45/04 (2013.01)
USPC **281/5**; 270/1.01; 493/405

(71) Applicant: **HUNKELER AG**, Wikon (CH)

(72) Inventors: **Franz HUNKELER**, Wikon (CH);
Erich HODEL, Wikon (CH)

(73) Assignee: **HUNKELER AG**, Wikon (CH)

(21) Appl. No.: **14/296,902**

(22) Filed: **Jun. 5, 2014**

Related U.S. Application Data

(62) Division of application No. 12/458,639, filed on Jul. 17, 2009.

Foreign Application Priority Data

Jul. 17, 2008 (EP) 08 012 915.8

(57) **ABSTRACT**

In a material web which is printed in a digital printing station and moved in an advancement direction, a first material-web strand, which is formed by at least one printed material-web portion, is combined with a second material-web strand, which is formed by two printed material-web portions, by folding. The two material-web strands are connected to one another by an adhesive. Subproducts are then severed from the thus interconnected material-web strands by cross-cutting. These subproducts comprise a first printed sheet, severed from the first material-web strand, and a second printed sheet, connected to the first printed sheet and severed from the second material-web strand. The subproducts are then positioned one upon the other to form a stack, the subproducts being connected to one another by an adhesive in the region of the subsequent folding line. The stacked subproducts are then folded about a folding line to form an end product.

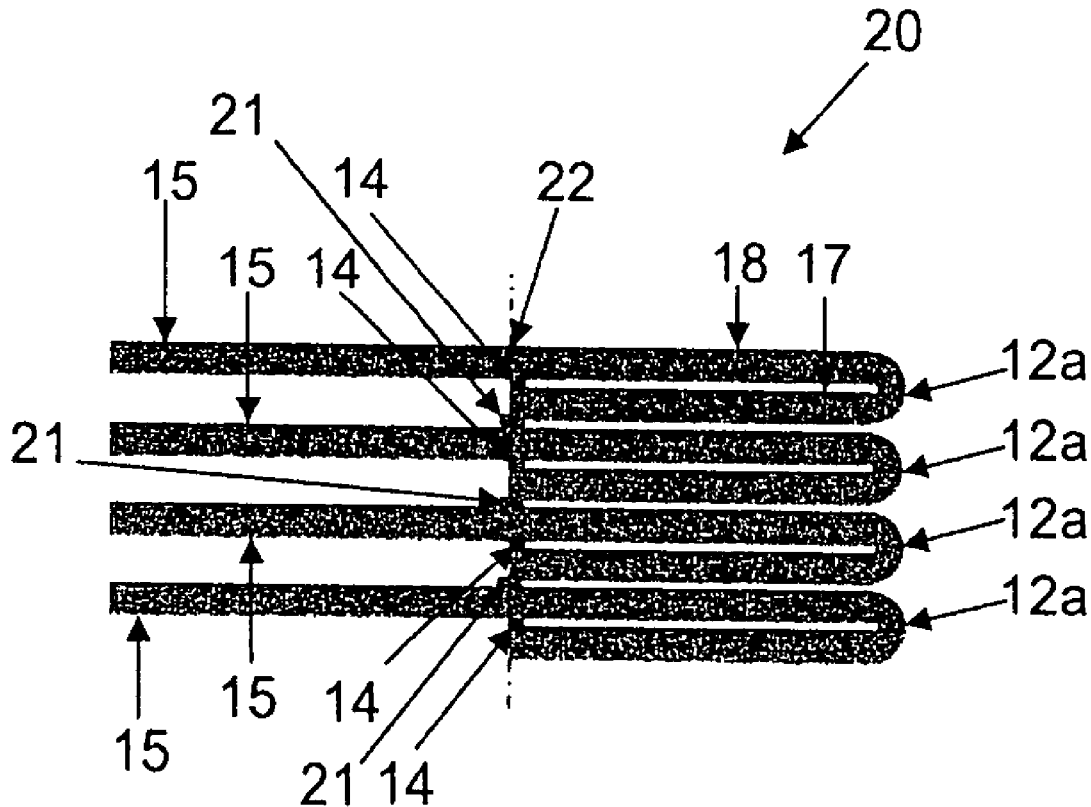

Fig. 1

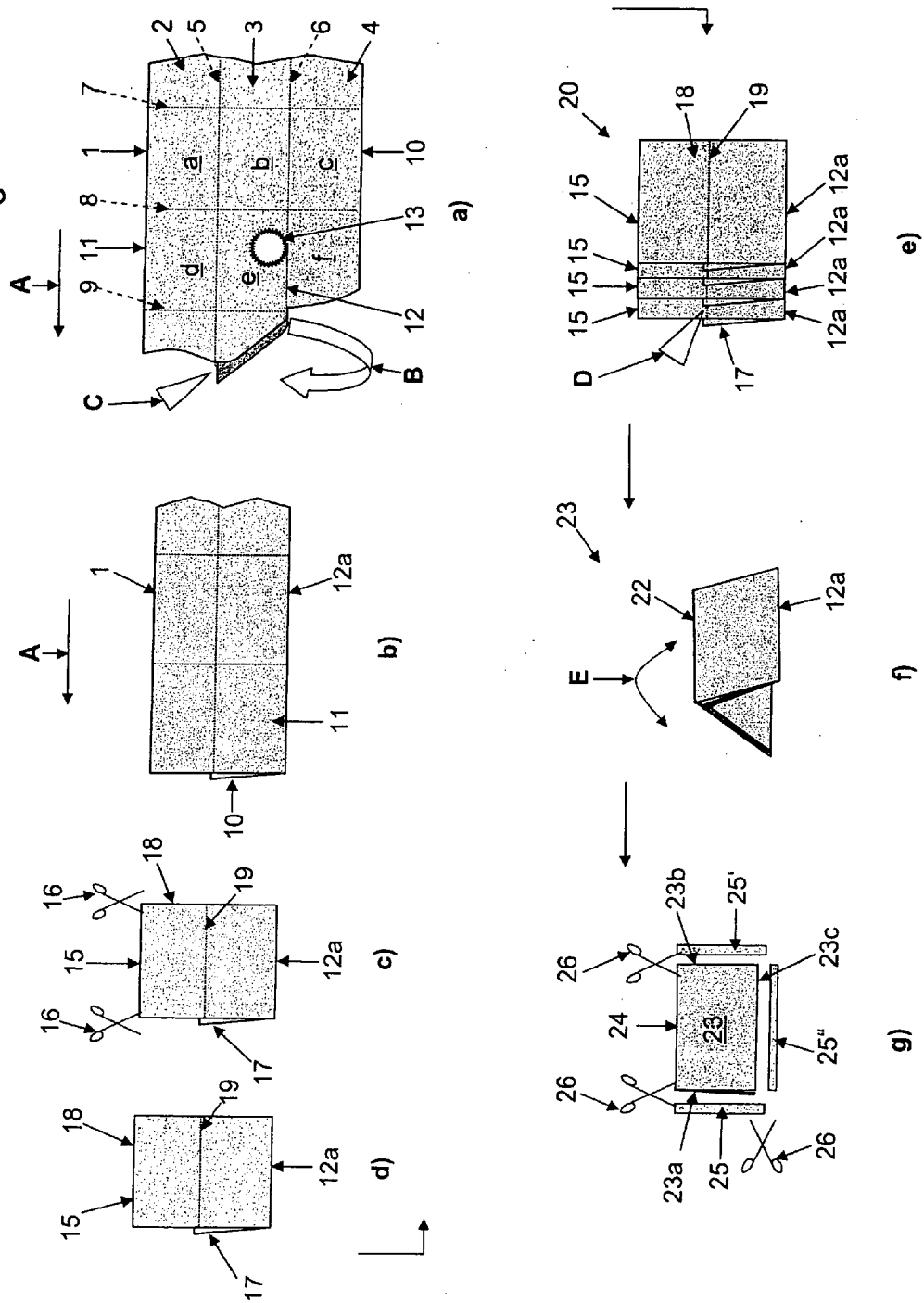

Fig. 2

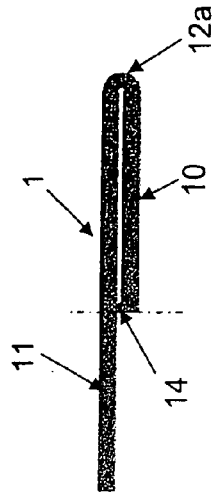

Fig. 3

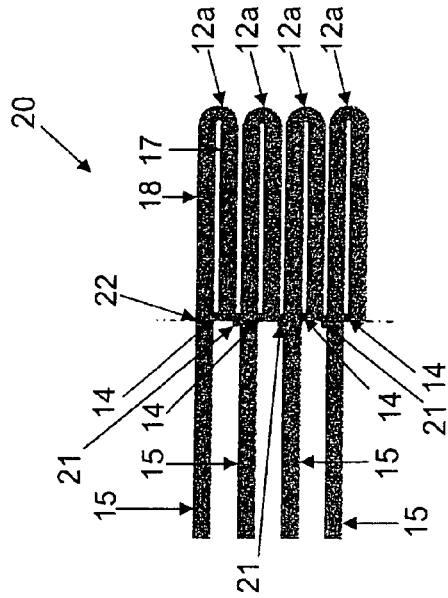

Fig. 4

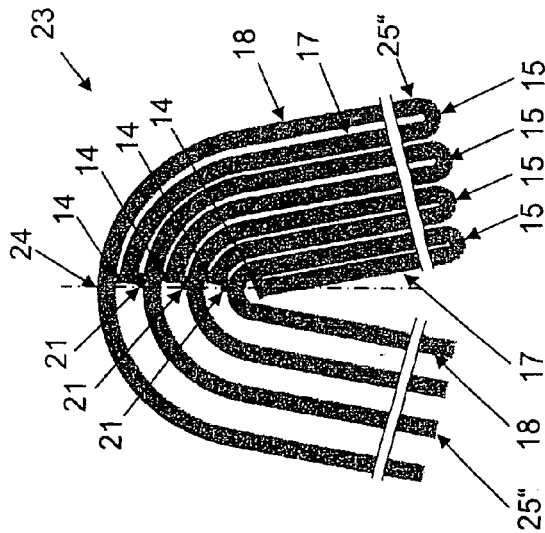

Fig. 5

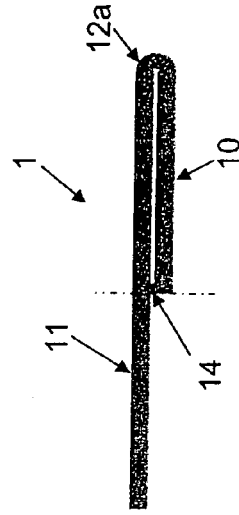

Fig. 6

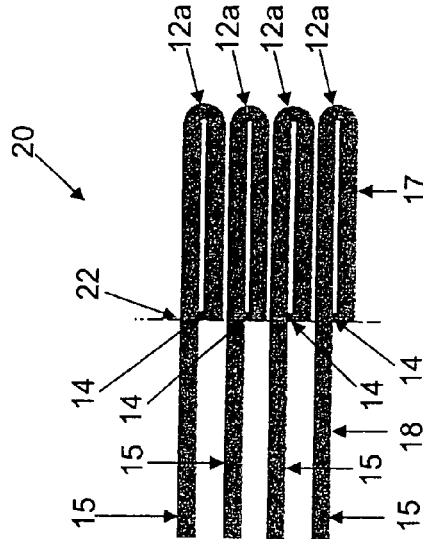

Fig. 7

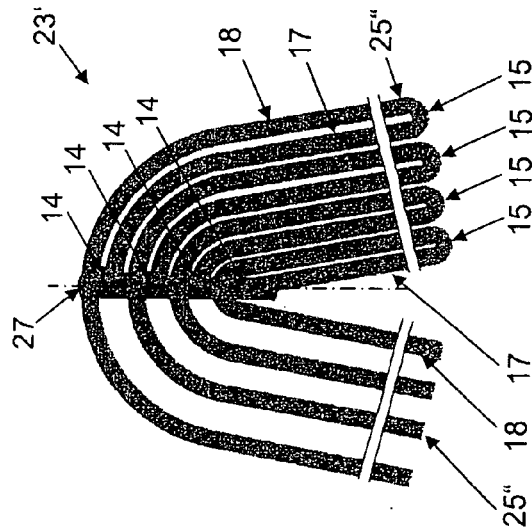

Fig. 8

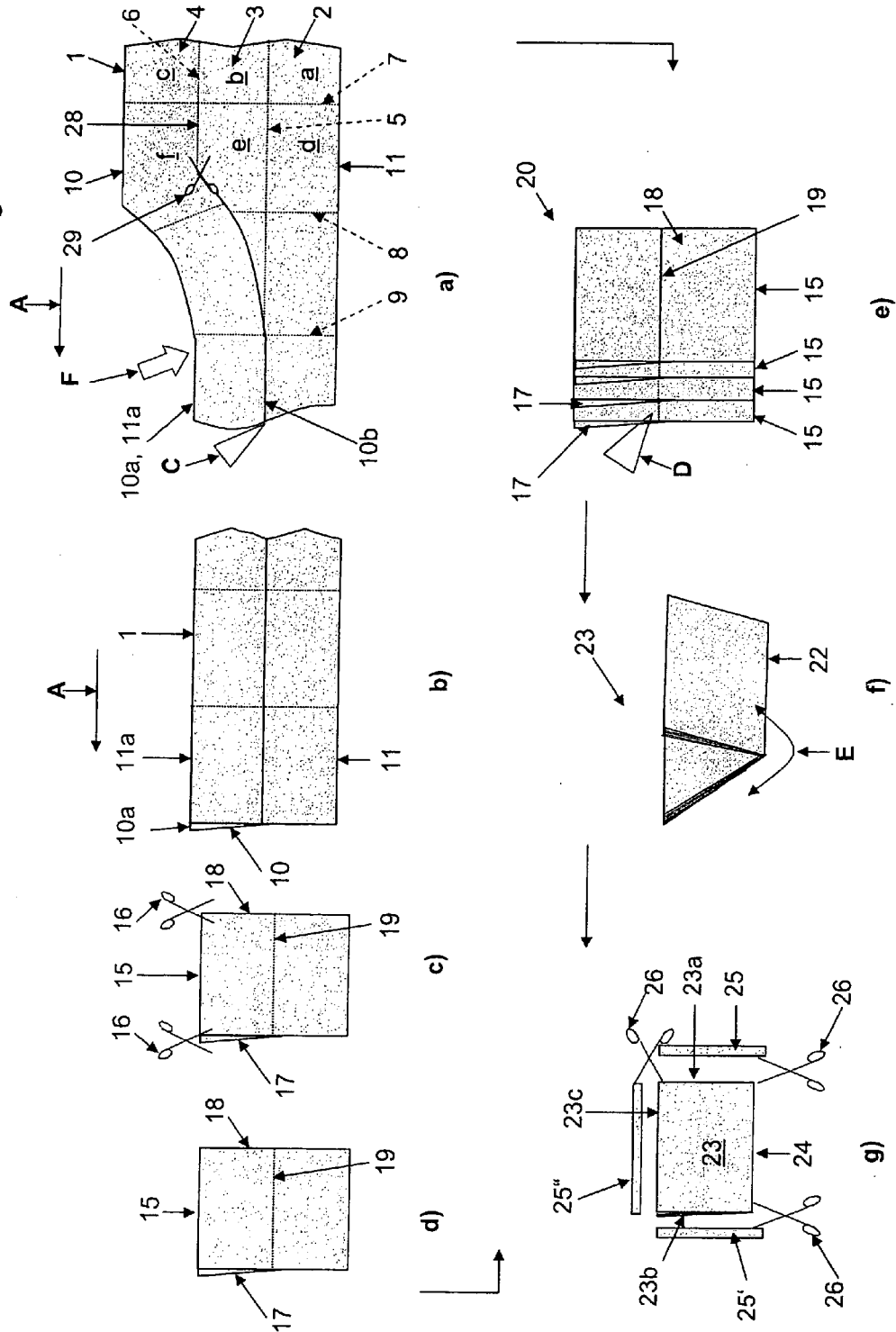

Fig. 9

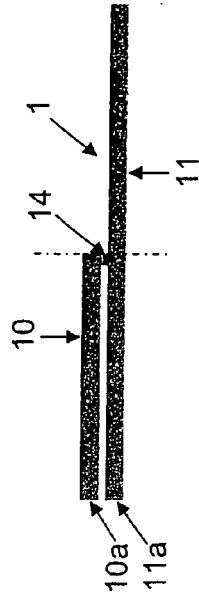

Fig. 10

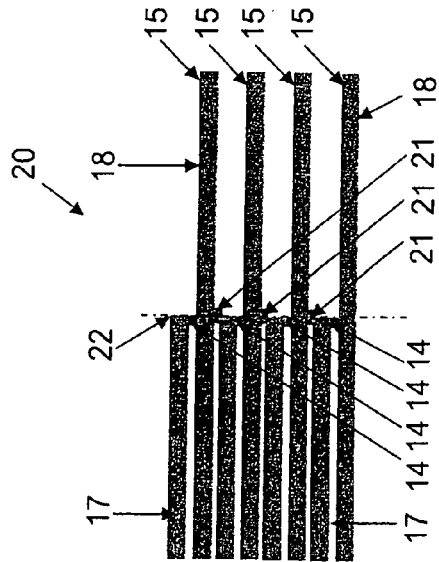

Fig. 11

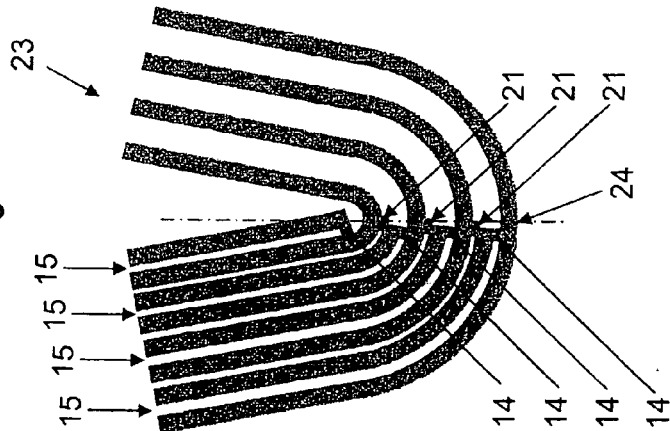

Fig. 12

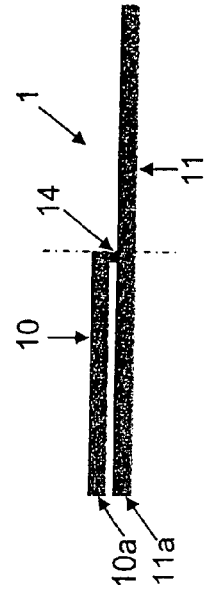

Fig. 13

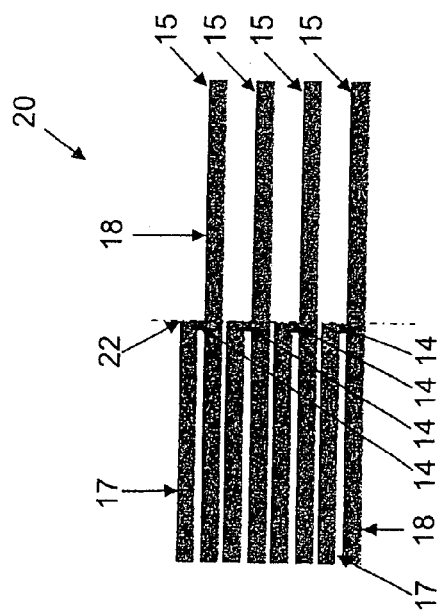

Fig. 14

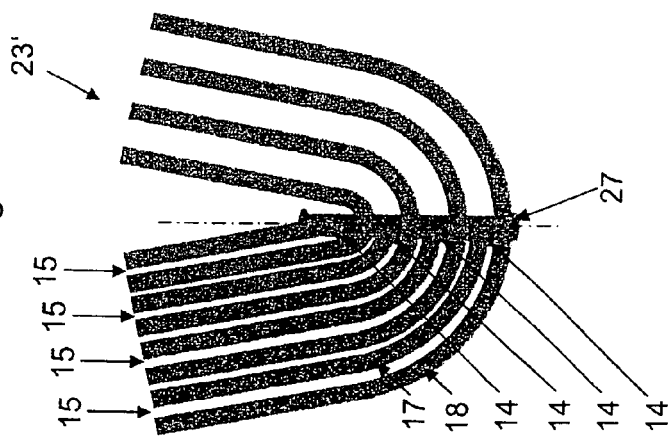
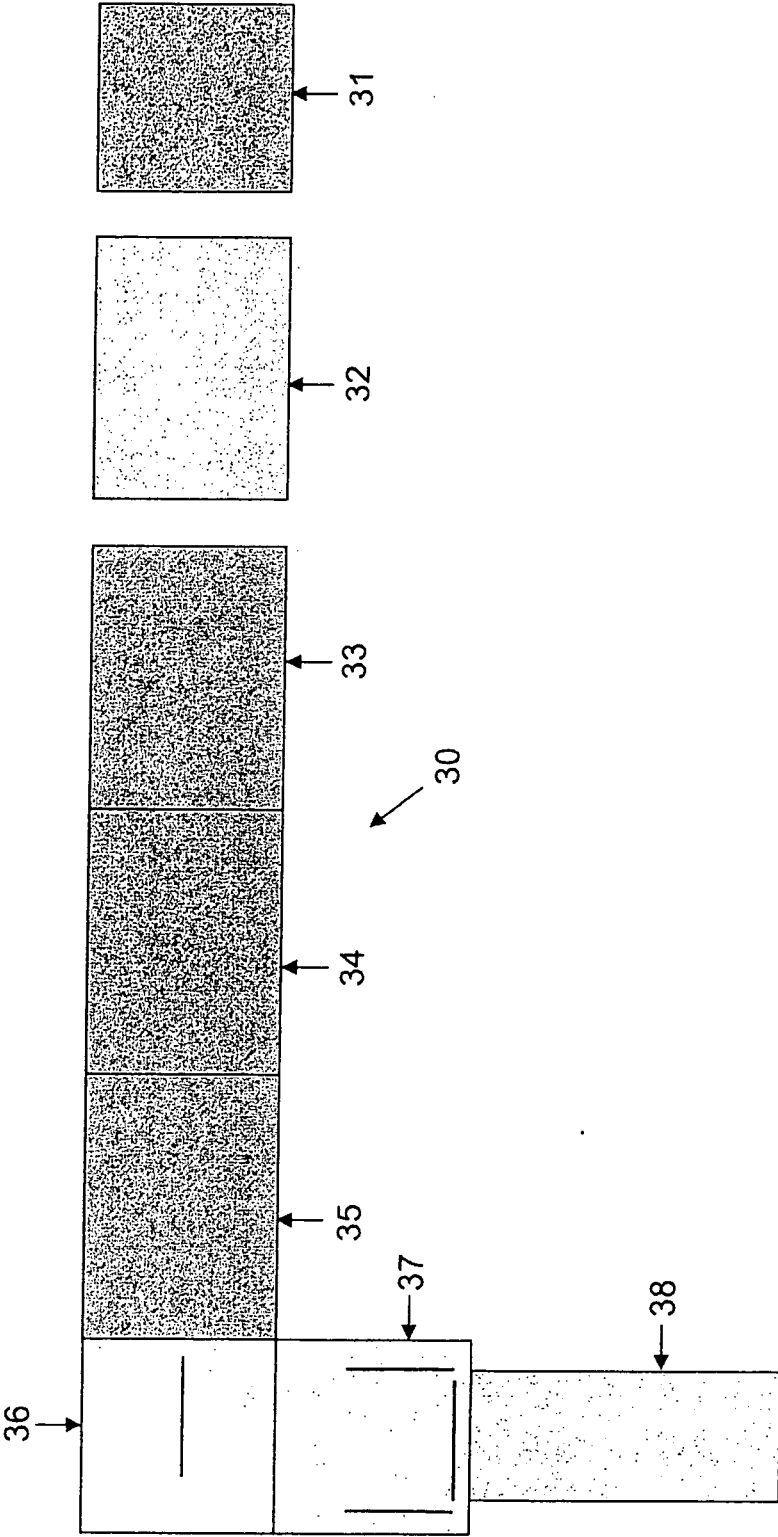

Fig. 15



**METHOD OF, AND APPARATUS FOR,
PRODUCING MULTI-LEAF, FOLDED
PRINTED PRODUCTS, IN PARTICULAR
PERIODICALS AND BROCHURES**

**CROSS-REFERENCE TO RELATED
APPLICATIONS**

[0001] This is a Division of Application No. 12/458,639, filed Jul. 17, 2009, which in turn claims priority under 35 U.S.C. §119 from European Patent Application No. 08 012 915.8, filed on Jul. 17, 2008. The disclosures of the prior applications are hereby incorporated by reference herein in their entirety.

BACKGROUND

[0002] In the production of printed products, such as periodicals, brochures, booklets and the like, in digital printing, the pages of a printed product are printed one after the other. Only after all the pages of a product have been printed the printing of the next product begins.

[0003] The digital printers which have been available up until now, and which can be used to print material webs of a width of up to 50 cm, make it possible, for producing printed products of DIN A4 format (or 8½×11 inch), for two pages of the same product which have their longitudinal side running parallel to the longitudinal extent of the material web to be printed one beside the other (so-called double use). However, use is already being made of digital printing machines which can print material webs of a width of 67 cm. Such digital printing machines make it possible, in the case of printed products of the abovementioned DIN A4 format, for three pages of the same product to be printed one beside the other (triple use).

SUMMARY

[0004] Taking as a basis a material web which is printed in a digital printing machine and is printed with three or more pages of a printed product arranged one beside the other, it is therefore an object of the present invention to produce finished printed products in a manner that is as straightforward and time-saving, and therefore cost-effective, as possible.

[0005] This object is achieved according to the invention by a method having the features of claim 1 and by an apparatus having the features of claim 9. The printed product produced in the manner according to the invention is distinguished by the features of claims 15 and 16.

[0006] Production of a folded end product taking as its basis a material web with three or more printed material-web portions arranged one beside the other proceeds straightforwardly here as follows:

[0007] In a first step, with the material web moving forward, a first material-web strand is brought together with a second material-web strand and connected to the latter by means of an adhesive along a connecting line which runs in the longitudinal direction of the material web in the region of a subsequent folding line. The material-web strands here can be combined in various ways, but preferably as defined in claims 5 and 6.

[0008] In a second step, subproducts are severed continuously from the two interconnected and advancing material-web strands by cross-cutting. These subproducts are stacked,

in a third step, to form a stack. During stacking or following stacking, the subproducts are connected to one another in a fourth step.

[0009] In a further, fifth step, the subproducts are folded individually, i.e. prior to stacking, or as a stack.

[0010] In a corresponding manner, it is also possible, according to claim 8, to produce end products from a printed material web which has four printed material-web portions arranged one beside the other.

[0011] Other preferred developments of the method according to the invention and of the apparatus according to the invention form the subject matter of the rest of the dependent claims.

BRIEF DESCRIPTION OF THE DRAWINGS

[0012] The invention will be explained in more detail hereinafter with reference to the drawings, in which, purely schematically:

[0013] FIG. 1 shows the sequence of the method according to the invention for a first embodiment,

[0014] FIG. 2 shows a front view of the two material-web strands combined and connected to one another during the method according to FIG. 1,

[0015] FIG. 3 shows a front view of the subproducts positioned one upon the other to form a stack and connected to one another during the method according to FIG. 1,

[0016] FIG. 4 shows a front view of a folded end product produced by the method according to FIG. 1,

[0017] FIGS. 5-7 show, in illustrations corresponding to FIGS. 2 to 4, intermediate products and end products which are produced according to a variant of the method illustrated in FIG. 1,

[0018] FIG. 8 shows the sequence of the method according to the invention for a second embodiment,

[0019] FIG. 9 shows a front view of the two material-web strands combined and connected to one another during the method according to FIG. 8,

[0020] FIG. 10 shows a front view of the subproducts positioned one upon the other to form a stack during the method according to FIG. 8,

[0021] FIG. 11 shows a front view of a folded end product produced by the method according to FIG. 8,

[0022] FIGS. 12-14 show, in illustrations corresponding to FIGS. 9 to 11, intermediate products and end products which are produced according to a variant of the method illustrated in FIG. 8, and

[0023] FIG. 15 shows a plan view of an installation for producing printed products by the method according to FIG. 1.

DETAILED DESCRIPTION OF EMBODIMENTS

[0024] The Figures will now be used to explain a first embodiment of the method according to the invention.

[0025] The material web 1, which is printed in a digital printing station, has three printed material-web portions 2, 3 and 4 of equal width arranged one beside the other. FIG. 1a indicates the delimitation between the material-web portions 2, 3 by dotted lines 5, 6 which run in the longitudinal direction of the material web 1. Each material-web portion 2, 3, 4 is printed with successive pages of a printed product, in each case 3 pages a, b, c and d, e, f being arranged one beside the other with their longitudinal sides running parallel to the longitudinal direction of the material web 1. The delimitation

between the individual pages of each material-web strand 2, 3, 4 in the longitudinal direction of the material-web 1 is indicated by dotted lines 7, 8 and 9.

[0026] The material web 1, coming from the digital printing station, is moved forward in the direction of the arrow A, running in the longitudinal direction of the material web 1. During this forward movement, a first material-web strand 10, which is formed by the material-web portion 4, is folded against a second material-web strand 11, which is formed by the two other material-web portions 2 and 3, about a line 12 which runs parallel to the advancement direction A and coincides with the delimitation line 6, this being indicated by the arrow B in FIG. 1a. The second material-web strand 11 is double the width of the first material-web strand 10. Prior to the material-web strand 10 being folded over, the material web 1 is perforated along the folding line 12, as is indicated in FIG. 1a by the merely schematically illustrated perforating tool 13. This perforating operation, which serves as a preparatory step for the subsequent folding operation, can also be left out.

[0027] In order to connect the material-web strands 10 and 11 combined in this way, an adhesive is applied to the second material-web strand 11 in the longitudinal direction of the material web 1 in the region of the center line of the material-web strand 11, i.e. in the region of the delimitation line 5, this being indicated in FIG. 1a by the arrow C. FIG. 2 illustrates a front view of the material web 1 with the two material-web strands 10, 11 connected to one another, the adhesive connection being designated by 14 and the folding edge being designated by 12a.

[0028] In a next step, subproducts 15 are severed continuously, along a line running transversely to the advancement direction A, from the material web 1, which is advanced further in the advancement direction A and has the first material-web strand 10 folded over against the second material-web strand 11 and adhesively bonded thereto (FIG. 1b), this severing being symbolized in FIG. 1c by the scissors 16. Each subproduct 15 comprises a first printed sheet 17, severed from the first material-web strand 10, and a second printed sheet 18, severed from the second material-web strand 11. The two sheets 17 and 18 are adhesively bonded to one another in the region of a center line 19 of the second sheet 18.

[0029] These subproducts 15 (FIG. 1d) are then positioned one upon the other, with their folding edges 12a aligned in relation to one another, to form a stack 20, which is illustrated schematically in FIG. 1e. Each subproduct 15 here is connected by means of an adhesive to the previous subproduct 15 on the stack 20 in the region of the center line 19 of the second sheet 18, this center line coinciding with the longitudinal center line of the broader material-web strand 11 and of the subsequent folding line. The application of an adhesive to the second sheet 18 is indicated in FIG. 1e by the arrow D. FIG. 3 shows a front view of the subproducts 15 positioned one upon the other to form the stack 20, the adhesive connection between the subproducts 15 being designated by 21.

[0030] In the following method step, the stacked subproducts 15 are folded along a folding line 22, which coincides with the center line 19 of the second sheets 18, to form an end product 23, this being indicated in FIG. 1f by the arrow E. FIG. 4 illustrates a front view of the folded end product 23, of which the folding edge is designated by 24.

[0031] As is shown in FIG. 1g, finally the end product 23 is trimmed along the side edges 23a, 23b, which are adjacent to the folding edge 24, and along the side edge 23c, which is

located opposite the folding edge 24. Edge portions 25, 25', 25'' are cut away here along these side edges 23a-c, as is symbolized by the scissors 26.

[0032] The operation of cutting away the edge portions 25 and 25' can be done away with in some circumstances, e.g. when the quality of the end product 23 does not have to meet particularly stringent requirements.

[0033] With reference to FIGS. 5 to 7, which correspond to the illustrations of FIGS. 2 to 4, a description will now be given of a variant of the method which has been explained above with reference to FIG. 1.

[0034] In the case of this variant, the operations of folding over the first material-web strand 10 and of adhesively bonding the latter to the second material-web strand 11 are identical to those in the method described with reference to FIG. 1. FIG. 5 is therefore identical to FIG. 2. It is also the case that the operations of severing subproducts 15 according to FIGS. 1c and 1d and of stacking the subproducts 15 to form a stack 20 take place in the manner already described.

[0035] In contrast to the method described with reference to FIG. 1, in this variant the subproducts 15 are not connected to one another when they are positioned one upon the other to form the stack 20, that is to say the operation of applying an adhesive between the subproducts 15 located one upon the other, and thus the adhesive connection 21 itself, are dispensed with. This can be seen from FIG. 6, which otherwise corresponds to FIG. 3.

[0036] The subproducts 15 located one upon the other are folded about a folding line 22 to form an end product 23', the stacked subproducts 15 being connected to one another in a suitable manner, preferably by stapling, prior to, or following, folding along the folding line 22 or the folding edge 24. FIG. 7, which corresponds to FIG. 4, shows a front view of the folded and stapled end product 231, the schematically illustrated stapling connection being designated by 27.

[0037] If required, the end product 23' can, as is described with reference to FIG. 1e, be trimmed along the side edges.

[0038] FIG. 8, which corresponds in illustrative terms to FIG. 1, will now be used to explain a second embodiment of the method according to the invention.

[0039] This second embodiment differs from the first embodiment according to FIG. 1 by a different way of combining the two material-web strands 10 and 11. For corresponding features and parts in FIG. 8 and the associated FIGS. 9 to 11, use is therefore made of the same designations as in FIGS. 1 to 7. The description of this second embodiment will make repeated reference to the description relating to FIGS. 1 to 7.

[0040] During the forward movement of the printed material web 1 coming from a digital printing station, the first, narrower material-web strand 10, rather than being folded over, as in the case of the first embodiment, against the second material-web strand 11, is severed from the second material-web strand 11 along a cutting line 28, which runs parallel to the advancement direction A and coincides with the delimitation line 6, this severing being symbolized in FIG. 8a by the scissors 29. The cut-off material-web strand 10 is then positioned on the second material-web strand 11 such that the two material-web strands 10 and 11 are aligned with one another along one of their longitudinal edges 10a, 11a, this being indicated in FIG. 8a by the arrow F. At the same time, the first material-web strand 10—in the same way as in the first embodiment—is connected to the second material-web strand 11 by means of an adhesive along its other longitudinal

edge **10b**. The application of the adhesive to the second material-web strand in the longitudinal direction of the material web **1** in the region of the center line of the second material-web strand **11**, i.e. in the region of the delimitation line **5**, is indicated by the arrow **C**.

[0041] The rest of the method steps illustrated in FIGS. **8b** to **8g**, namely the operations of severing subproducts **15** from the material web **1** with the first material-web strand **10** positioned on the second material-web strand **11** and connected thereto (FIGS. **8b** to **8d**), of stacking the subproducts **15** to form a stack **20** (FIG. **8e**), of folding the stacked subproducts **15** along a folding line **22** to form an end product **23** (FIG. **8f**) and of trimming the end product **23** along the side edges **23a**, **23b**, **23c** (FIG. **8g**) take place in the same way as for the first exemplary embodiment. Reference is therefore made to the appropriate explanations in the description of the method according to FIG. **1**. It should be mentioned, however, that the operation of trimming the end product **23** along the side edges **23a** and **23b** is not usually necessary any longer since one of these side edges **23a**, **23b** is formed by a region of a longitudinal edge of the material web **1** and the other side edge is formed by a region of the cutting edge **28**.

[0042] The material web **1** which is shown in front view in FIG. **9** and has material-web strands **10**, **11** located one above the other and connected to one another differs from the material web **1** which is shown in FIG. **2** only by the fact that the material-web strands **10**, **11** are not connected to one another along their aligned longitudinal edges **10a**, **11a**. The same applies to the stacked subproducts **15**, which are shown in FIG. **10**, and to the end product **23** according to FIG. **11**.

[0043] FIGS. **12** to **14**, which correspond in illustrative terms to FIGS. **9** to **11**, will now be used to explain a variant of the second embodiment of the method according to the invention in FIG. **8**.

[0044] This variant corresponds to the variant according to FIGS. **5** to **7**. This means that, in the case of the variant which is shown in FIGS. **12** to **14**, the subproducts **15** are not connected to one another, and the adhesive connection **21** is thus dispensed with, as they are positioned one above the other. Instead, the stacked subproducts **15** are connected to one another, preferably by stapling, prior to, or following, folding along the folding edge **24**. This stapling connection is designated by **27** in FIG. **14**, just as it was in FIG. **7**.

[0045] FIG. **15** will now be used to describe an apparatus for implementing the method according to the invention (first and second exemplary embodiments).

[0046] FIG. **15** shows, purely schematically and in plan view, a processing line **30** which has an unwinding station **31** by means of which the material web which is to be printed can be unwound from a roll. This unwinding station **31** may be, for example, a "Unwinding Module UW6" as sold by the applicant. The unwinding station **31** has a digital printing station **32** arranged downstream of it. The material web, which is printed in this digital printing station **32**, is fed to a combining station **33**, in which the material-web strands **10**, **11** are combined and connected to one another by means of an adhesive. For implementing the first exemplary embodiment of the method according to the invention in FIG. **1**, the combining station **33** may be a longitudinal folding station of known construction. For implementing the second embodiment of the method according to the invention in FIG. **8**, the combining station **33** is a processing unit for severing the first material-web strand **10** from the second material-web strand **11** and then positioning the two material-web strands **10**, **11**

one above the other, as sold for example as "Web Merger WM6-Even" by the applicant. However, it is also possible to use, as combining station **33**, a combined processing station which optionally brings together the material-web strands **10**, **11** according to the first embodiment or according to the second embodiment. Such a combined processing station forms the subject matter of European patent application No 08 009 232.3 dated May 20, 2008 and the related U.S. patent application Ser. No. 12/453,661 filed May 18, 2009 and is sold as "Folder Merger FM6" by the applicant. Each embodiment of the combining station **33** is provided with a device for connecting the two material-web strands **10**, **11** along a connecting line by means of an adhesive.

[0047] The combining station **33** has a cross-cutting station **34** for severing the subproducts **15** arranged downstream of it. The CS6-I cross-cutting module as sold by the applicant is suitable as such a cross-cutting station **34**.

[0048] The subproducts **15** leaving the, cross-cutting station **34** are positioned one upon the other in a stacking station **35** to form a stack **20**. The collecting apparatus which is described in EP-A-1 471 022, and is sold as "Drum Collator DC7" by the applicant, is particularly suitable as the stacking station **35**. For implementing the method according to the invention in FIGS. **1** and **8**, the stacking station **35** is provided with a device for applying an adhesive to the respectively uppermost subproduct **15** in the stack **20** in the region of the subsequent folding line.

[0049] The subproducts **15** stacked in the stacking station **35** are folded in a folding station **36** to form an end product **23**. For the folding station **36**, use can be made of, for example, the folding apparatus described in EP-B-1 213 245 or of a ZK500 knife folder as sold by Griesser & Kunzmann GmbH & CO. KG, Wellendingen (Germany).

[0050] The folding station **36** is followed by a side-edge-cutting station **37**, in which the folded end products **23** are trimmed along the side edges **23a**, **23b** and **23c**. This side-edge-cutting station **37** can be dispensed with in some circumstances.

[0051] The finished end products **23** are transferred to a removal module **38** at the end of the processing line **30**.

[0052] For implementing the variant of the first and second embodiments of the method according to the invention, the processing line **30** which is shown in FIG. **15** is supplemented by a stapling station, which is arranged for example between the folding station **36** and the side-edge-cutting station **37**.

[0053] If the material web **1** is printed in the digital printing station **32** such that 4 printed material-web portions are arranged one beside the other, then end products are produced in a manner similar to that described above. In contrast to the embodiments described with reference to FIGS. **1** to **14**, the two combined material-web strands here are of the same width and each comprise two printed material-web portions arranged one beside the other. The subproducts which are produced in the manner described here then comprise a folded, outer printed sheet and a folded, inner printed sheet, which is arranged within the outer sheet. The two sheets are connected to one another by means of an adhesive in the region of the folding edge of the outer sheet.

[0054] A description will be given hereinbelow of a third exemplary embodiment of the subject matter of the invention, which is not shown in the Figures and in which the operations of stacking the subproducts **15** and of connecting the same to one another take place differently to the exemplary embodiments according to FIGS. **1** and **8**. In this third exemplary

embodiment, subproducts **15** are produced in the manner described with reference to FIGS. *1a-1d* and *8a-8d*. These subproducts **15**, then, are folded in the manner of a gable roof along the center line of the sheet **18** and are then positioned one above the other in straddling fashion to form a stack. In order to connect the subproducts **15** to one another, an adhesive is applied to the inside or outside of the subproducts **15**, along the folding line coinciding with the center line **19**, prior to the subproducts being positioned one above the other. The adhesive here may be applied continuously or just in certain regions. Such operations of subproducts being positioned one above the other and connected by means of adhesive are described in detail, for example, in WO-A-2005/072980.

[0055] In a variant of this third exemplary embodiment, it is possible for the subproducts located one above the other to be connected, not by means of an adhesive applied prior to or during stacking of the subproducts, but by stapling along the folding line of the subproducts.

What is claimed is:

1. An apparatus for producing multi-leaf, folded printed products, in particular periodicals and brochures, based on a material web which is printed in a digital printing station and has at least three printed material-web portions arranged one beside the other in its longitudinal direction, said apparatus comprising:

a combining station arranged downstream of a digital printing station and in which a first material-web strand, which is formed by at least one printed material-web portion, is combined with a second material-web strand, which is formed by two printed material-web portions, and which has a device for connecting the two material-web strands by means of an adhesive along a connecting line running in the longitudinal direction of the material web,

a cross-cutting station which is arranged downstream of the combining station and severs subproducts from the interconnected material-web strands by cutting transversely to the advancement direction of the material web,

means for advancing the printed material web through the combining station and to the crosscutting station,

a stacking station for stacking the subproducts to form a stack, and

a folding station for folding the individual subproducts or the stacked subproducts about a folding line.

2. The apparatus of claim **1**, wherein the combining station has a processing arrangement for folding the first material-web strand against the second material-web strand about a line parallel to the advancement direction of the material web or a processing arrangement for severing the first material-web strand along a line parallel to the advancement direction of the material web and then for positioning the two material-web strands one above the other.

3. The apparatus of claim **1**, further comprising:

a device for applying an adhesive to the subproducts in the region of the subsequent folding line to connect the subproducts to one another.

4. The apparatus of claim **3**, wherein the device for applying an adhesive to the subproducts is assigned to the stacking station.

5. The apparatus of claim **1**, further comprising:

a stapling station by means of which the subproducts located one upon the other are connected along the folding line.

6. The apparatus of claim **1**, wherein the folding station is arranged downstream of the stacking station and serves for folding the stacked subproducts.

7. The apparatus of claim **1**, wherein the folding station is arranged between the crosscutting station and the stacking station and serves for folding the individual subproducts.

8. A multi-leaf, folded printed product produced by a method based on a material web which is printed in a digital printing station and has at least three printed material-web portions arranged one beside the other in its longitudinal direction, the method including:

moving the material web in an advancement direction,

combining a first material-web strand, which is formed by at least one printed material-web portion, with a second material-web strand, which is formed by two printed material-web portions, by connecting the first material-web strand to the second material-web strand by means of an adhesive along a connecting line running in the longitudinal direction of the material web,

severing subproducts from the interconnected first and second material-web strands by cutting transversely to the advancement direction of the material web, the subproducts comprising a first printed sheet, severed from the first material-web strand, and a second printed sheet, connected to the first printed sheet and severed from the second material-webstrand,

stacking the subproducts to form a stack, wherein the subproducts are connected to one another during stacking or following stacking, and

folding the subproducts individually or as a stack about a folding line which runs between the adjacent printed portions of the second printed sheet,

the multi-leaf, folded printed product comprising:

a number of folded subproducts which are connected to one another in the region of their folding edges, the subproducts each including:

a folded, outer printed sheet; and

an inner printed sheet which is arranged within the outer sheet, corresponds sizewise to half the size of the outer sheet and is connected to the outer sheet in the region of the folding edge of the latter by means of an adhesive.

9. A multi-leaf, folded printed product produced by a method of producing a multi-leaf, folded printed product based on a material web which is printed in a digital printing station and has at least three printed material-web portions arranged one beside the other in its longitudinal direction, the method including:

moving the material web in an advancement direction,

combining a first material-web strand, which is formed by one of the at least three printed material-web portion, with a second material-web strand, which is formed by two of the at least three printed material-web portions, while the material web is moved in the advancement direction,

connecting the first material-web strand to the second material-web strand by means of an adhesive being applied in the longitudinal direction of the material web in a region of a center line of the second material-web strand,

severing subproducts from the interconnected first and second material-web strands by cutting transversely to the advancement direction of the material web, the subproducts comprising a first printed sheet, severed from the

first material-web strand, and a second printed sheet, connected to the first printed sheet and severed from the second material-web strand, wherein a width of the second printed sheet is double a width of the first printed sheet,

stacking the subproducts to form a stack, wherein:

the subproducts are connected to one another along or in the region of the center line of the second material-web strand during stacking or following stacking,

the first printed sheets are arranged alternately with the second printed sheets, the first printed sheets being severed from the first material-web strand and the second printed sheets being severed from the second material-web strand on the stack, and

folding the subproducts as a stack about a folding line which runs between the adjacent printed portions of the second printed sheet to form an end product wherein the folding line defines a first side and a second side of the end product and wherein the end product comprises on the first side twice the number of leaves than on the second side,

in the case of a material web which has four printed material-web portions arranged one beside the other, the material-web strands of equal width are combined either by one material-web strand being folded against the other material-web strand about the center line of the material web or by one material-web strand being severed and then the two material-web strands being positioned one above the other, and they are connected to one another along a connecting line running in the longitudinal direction of the material web,

the multi-leaf, folded printed product comprising:

a number of folded subproducts which are connected to one another in the region of their folding edges, the subproducts each comprising:

a folded, outer printed sheet; and

a folded, inner printed sheet which is arranged within the outer sheet, corresponds in size to the outer sheet and is connected to the outer sheet in the region of the folding edge of the latter by means of an adhesive.

* * * * *