



(19) **United States**

(12) **Patent Application Publication**
KWON et al.

(10) **Pub. No.: US 2021/0157762 A1**

(43) **Pub. Date: May 27, 2021**

(54) **PORTABLE STORAGE DEVICES AND METHODS OF OPERATING PORTABLE STORAGE DEVICES**

G06F 1/26 (2006.01)

G06F 1/3215 (2006.01)

G06F 1/08 (2006.01)

(71) Applicant: **SAMSUNG ELECTRONICS CO., LTD.**, SUWON-SI (KR)

(52) **U.S. Cl.**
CPC *G06F 13/4278* (2013.01); *G06F 13/4068* (2013.01); *G06F 1/08* (2013.01); *G06F 1/266* (2013.01); *G06F 1/3215* (2013.01); *G06F 13/385* (2013.01)

(72) Inventors: **JEAYOUNG KWON**, HWASEONG-SI (KR); **KYUNGHUN KIM**, SUWON-SI (KR); **NAMHOON KIM**, SUWON-SI (KR)

(57) **ABSTRACT**

A portable storage device includes nonvolatile memory devices to store data, a storage controller, and a bridge chipset. The bridge chipset is connected to a first connector of a host through a cable assembly, detects a resistance of the cable assembly, provides the storage controller with USB type information of the first connector based on the detected resistance, and after a USB connection is established with the host, provides the storage controller with USB version information associated with the established USB connection. The storage controller selects one of a plurality of initializing modes based on the USB type information and the USB version information, selects clock signals having frequencies in a range within a maximum power level, and performs an initializing operation based on the selected clock signals within an internal reference time interval.

(21) Appl. No.: **16/924,428**

(22) Filed: **Jul. 9, 2020**

(30) **Foreign Application Priority Data**

Nov. 27, 2019 (KR) 10-2019-0154141

Publication Classification

(51) **Int. Cl.**
G06F 13/42 (2006.01)
G06F 13/40 (2006.01)
G06F 13/38 (2006.01)

10

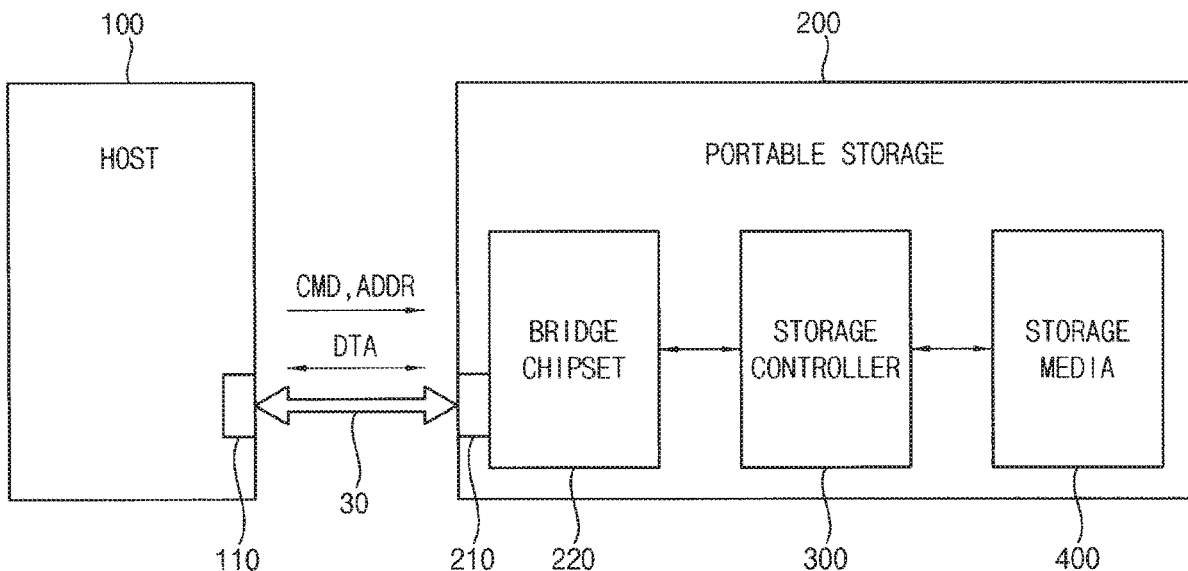


FIG. 1

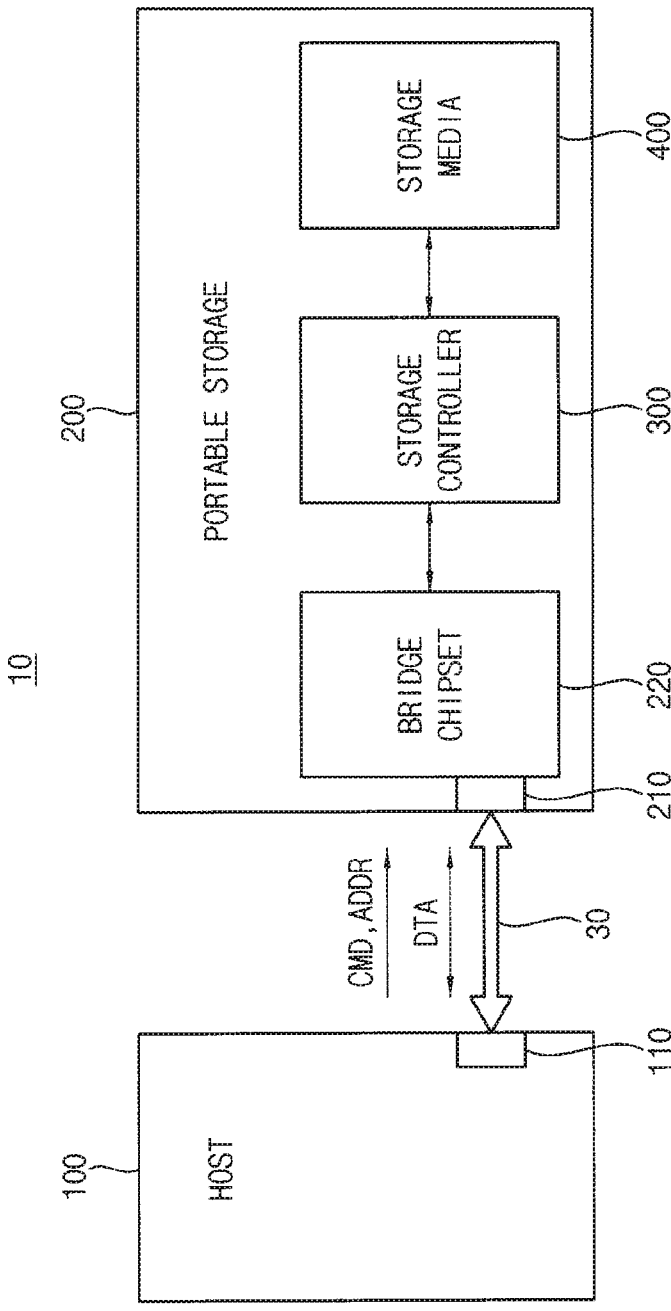


FIG. 2

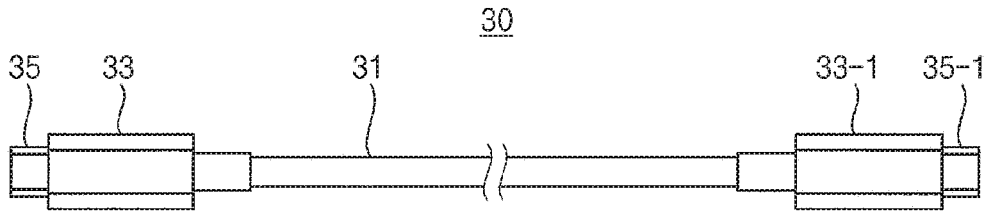


FIG. 3A

A1	A2	A3	A4	A5	A6	A7	A8	A9	A10	A11	A12
GND	TX1+	TX1-	VBUS	CC1	D+	D-	SBU1	VBUS	RX2-	RX2+	GND
GND	RX1+	RX1-	VBUS	SBU2	D-	D+	CC2	VBUS	TX2-	TX2+	GND
B12	B11	B10	B9	B8	B7	B6	B5	B4	B3	B2	B1

FIG. 3B

A12	A11	A10	A9	A8	A7	A6	A5	A4	A3	A2	A1
GND	RX2+	RX2-	VBUS	SBU1	D-	D+	CC	VBUS	TX1-	TX1+	GND
GND	TX2+	TX2-	VBUS	VCONN			SBU2	VBUS	RX1-	RX1+	GND
B1	B2	B3	B4	B5	B6	B7	B8	B9	B10	B11	B12

FIG. 3C

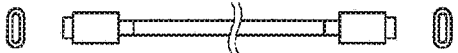
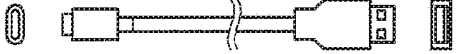

TYPE	CABLE
36 TYPE C TO C	
37 C TO STANDARD A	
38 C TO B RECEPTACLE	

FIG. 4

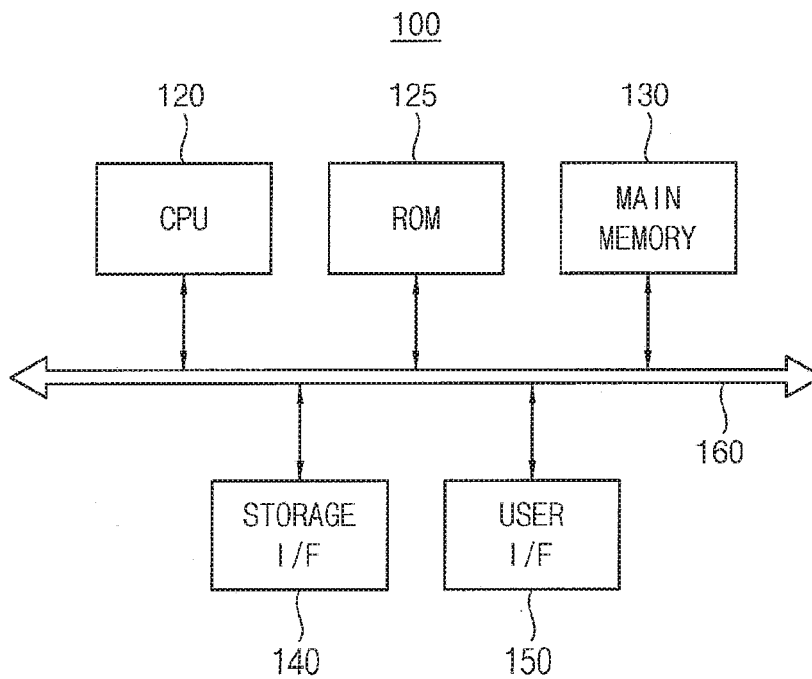


FIG. 5

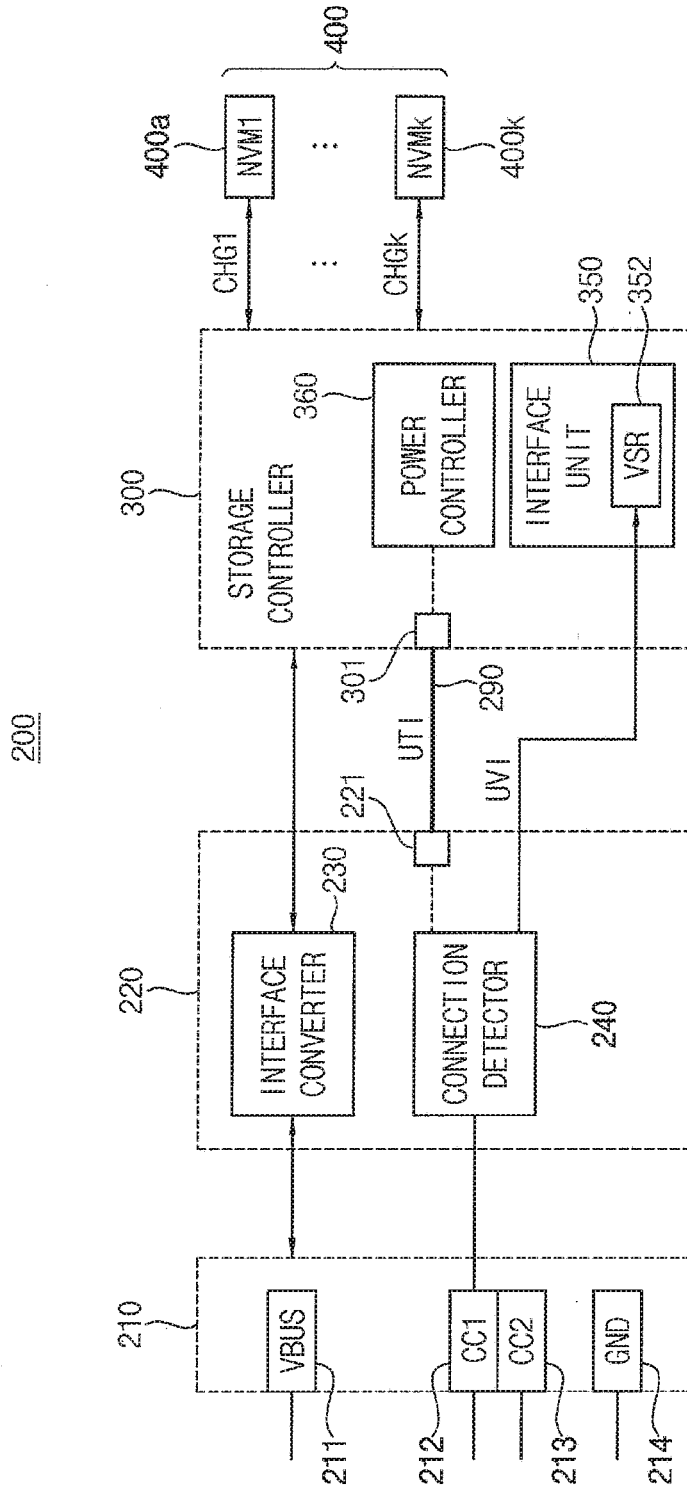


FIG. 6

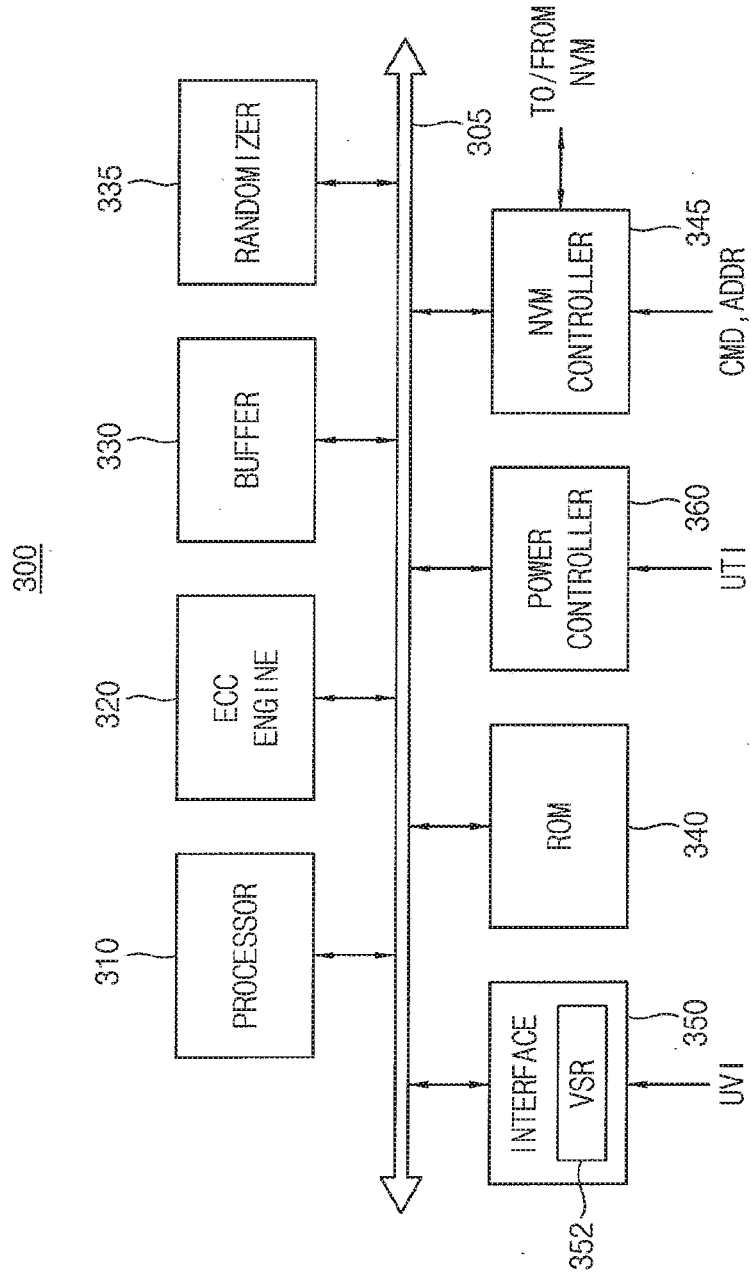


FIG. 7

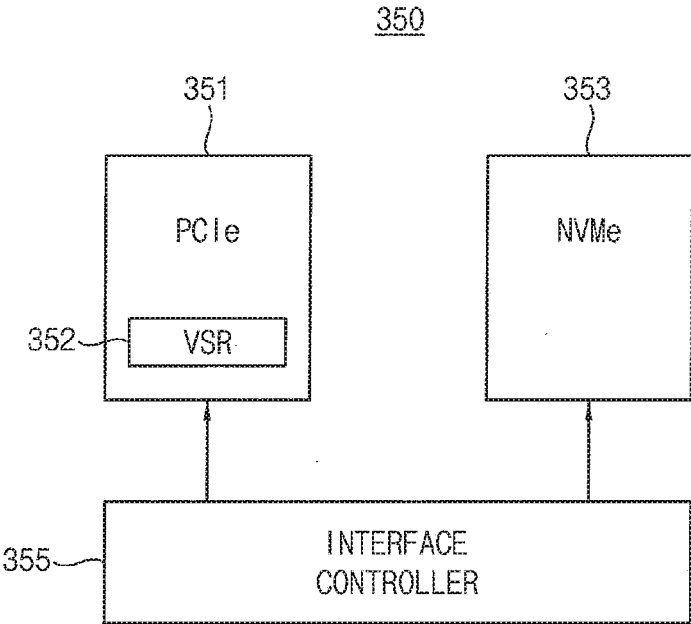


FIG. 8

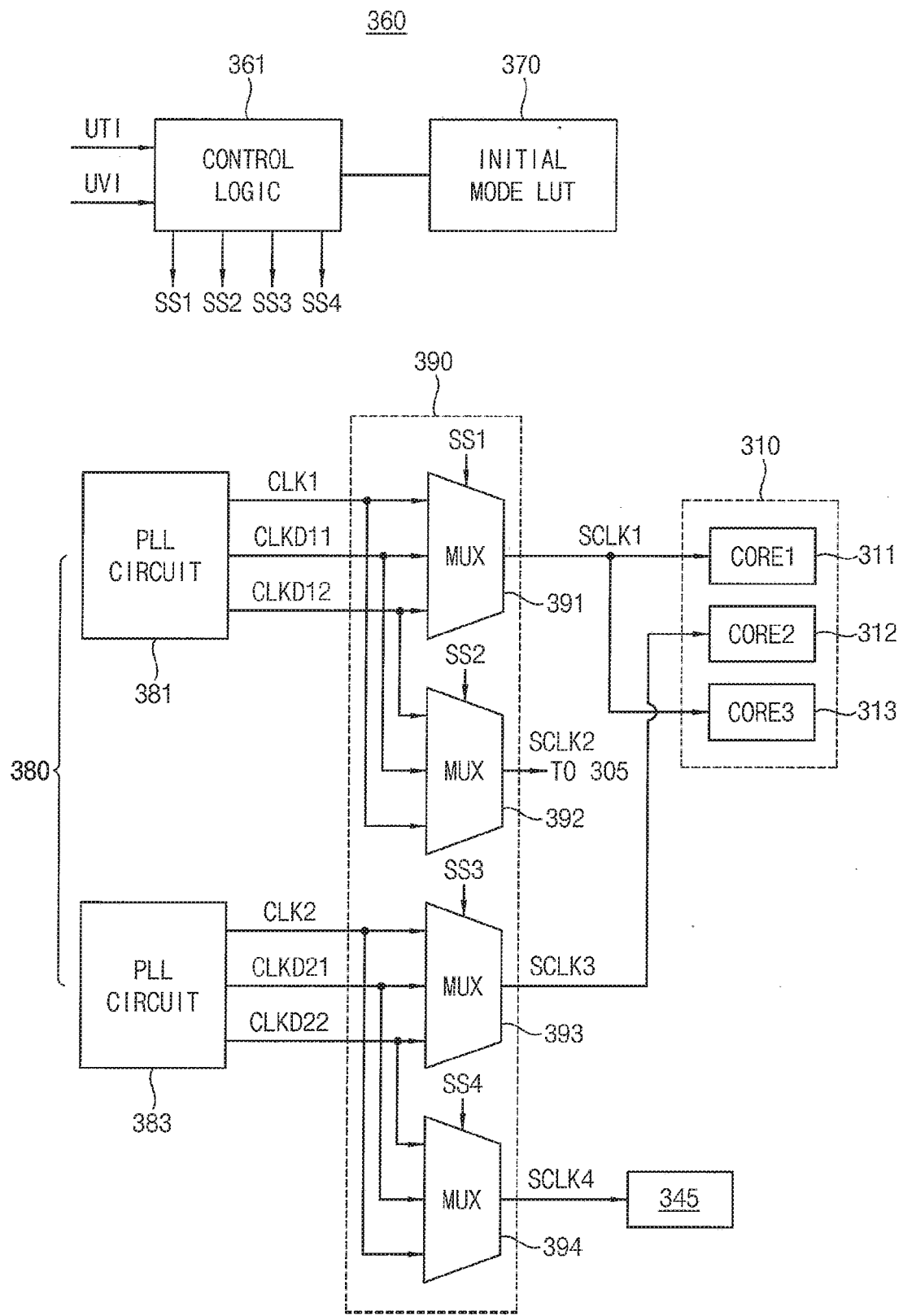


FIG. 9

370

USB TYPE	POWER TARGET	
TYPE C	HIGH	~ 371
TYPE A USB3.0 OR HIGHER	MIDDLE	~ 372
TYPE A USB2.0	LOW	~ 373

FIG. 10

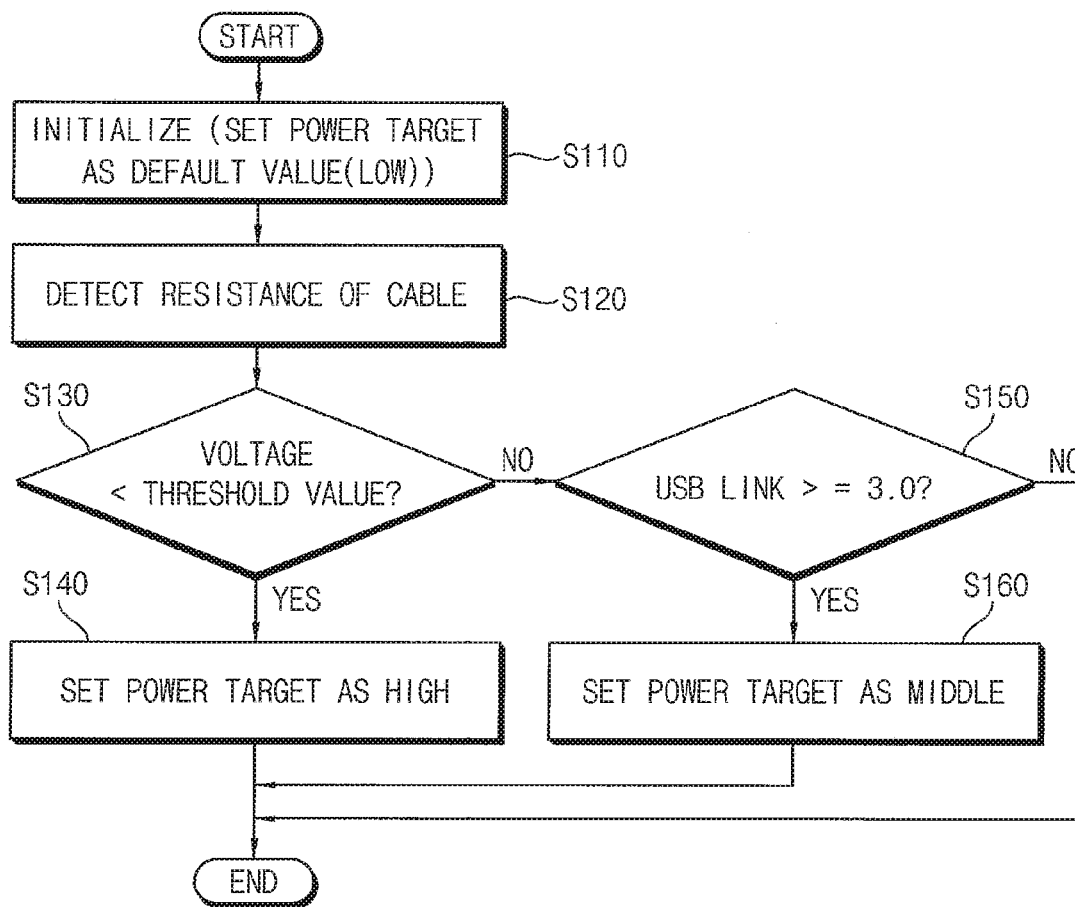


FIG. 11

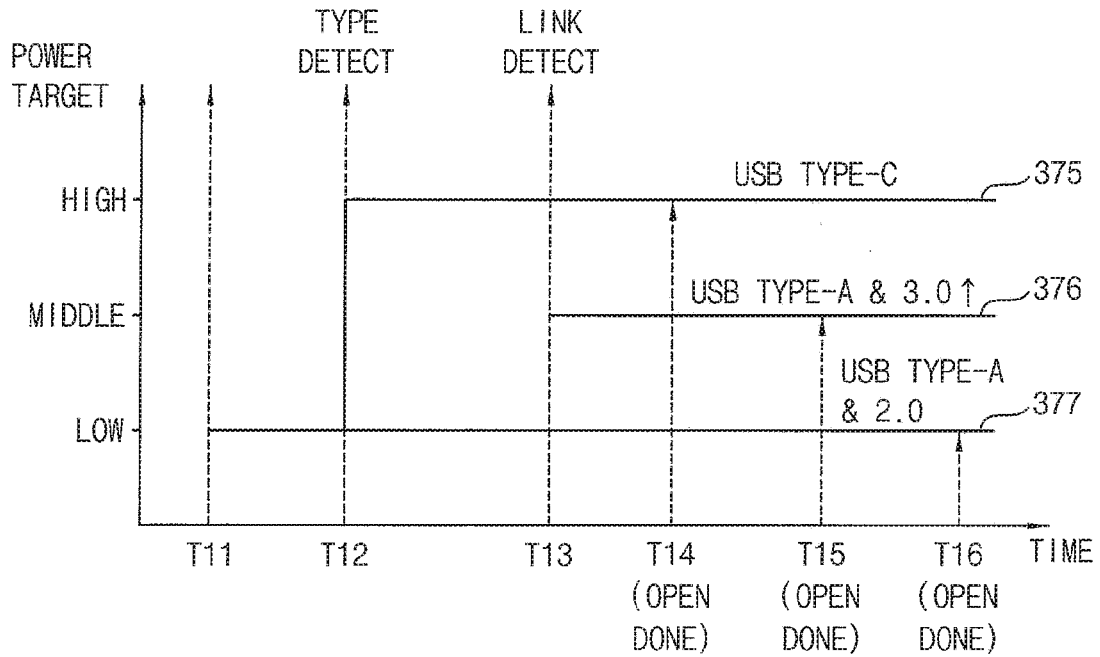


FIG. 12

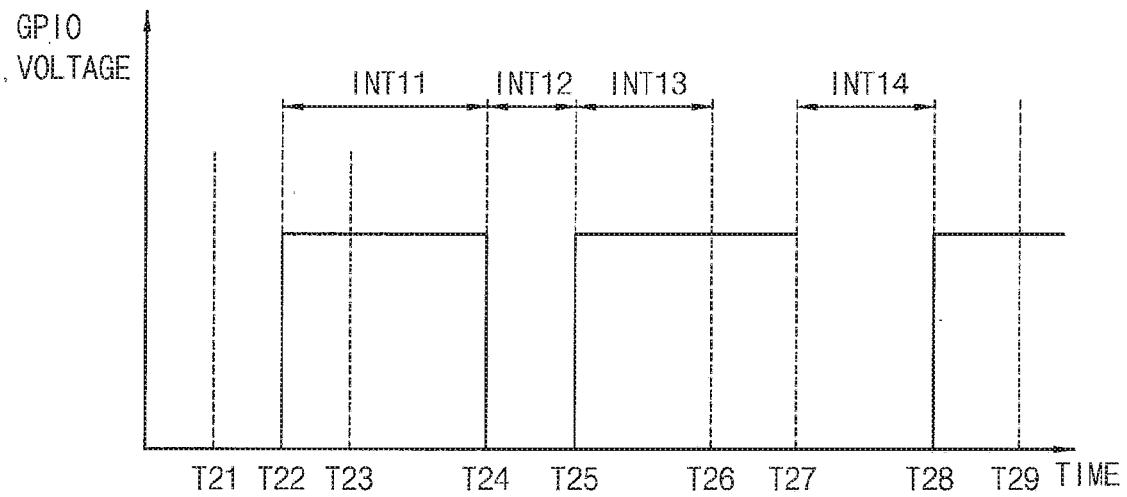


FIG. 13

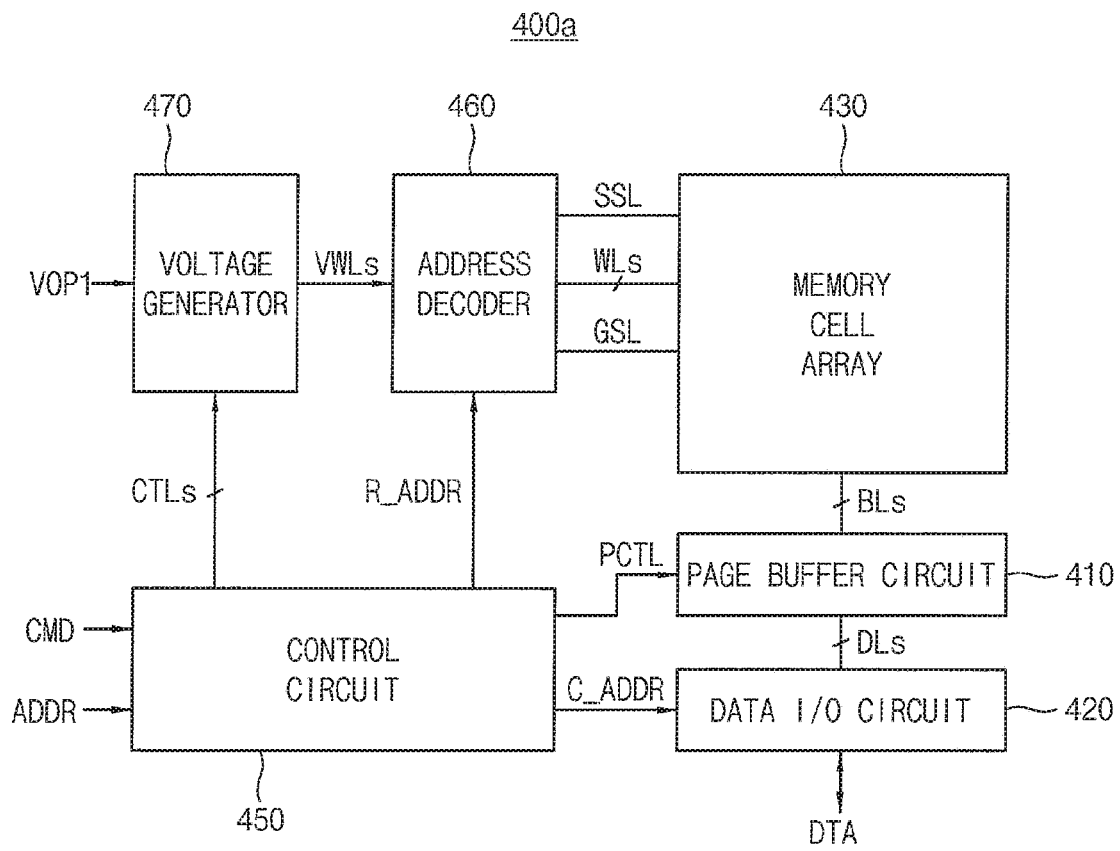


FIG. 14

430

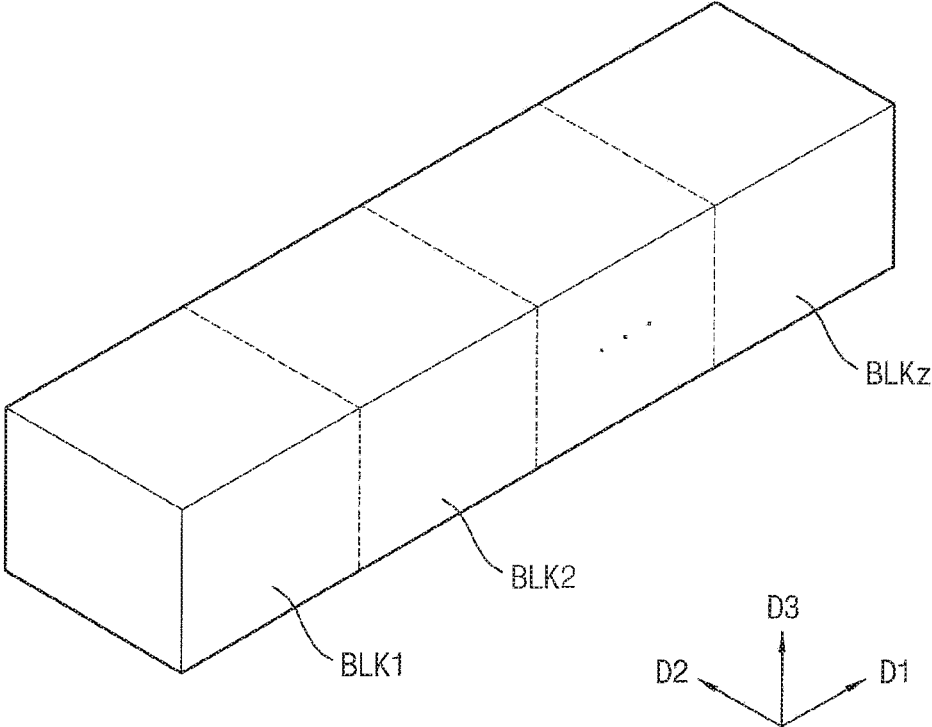


FIG. 15

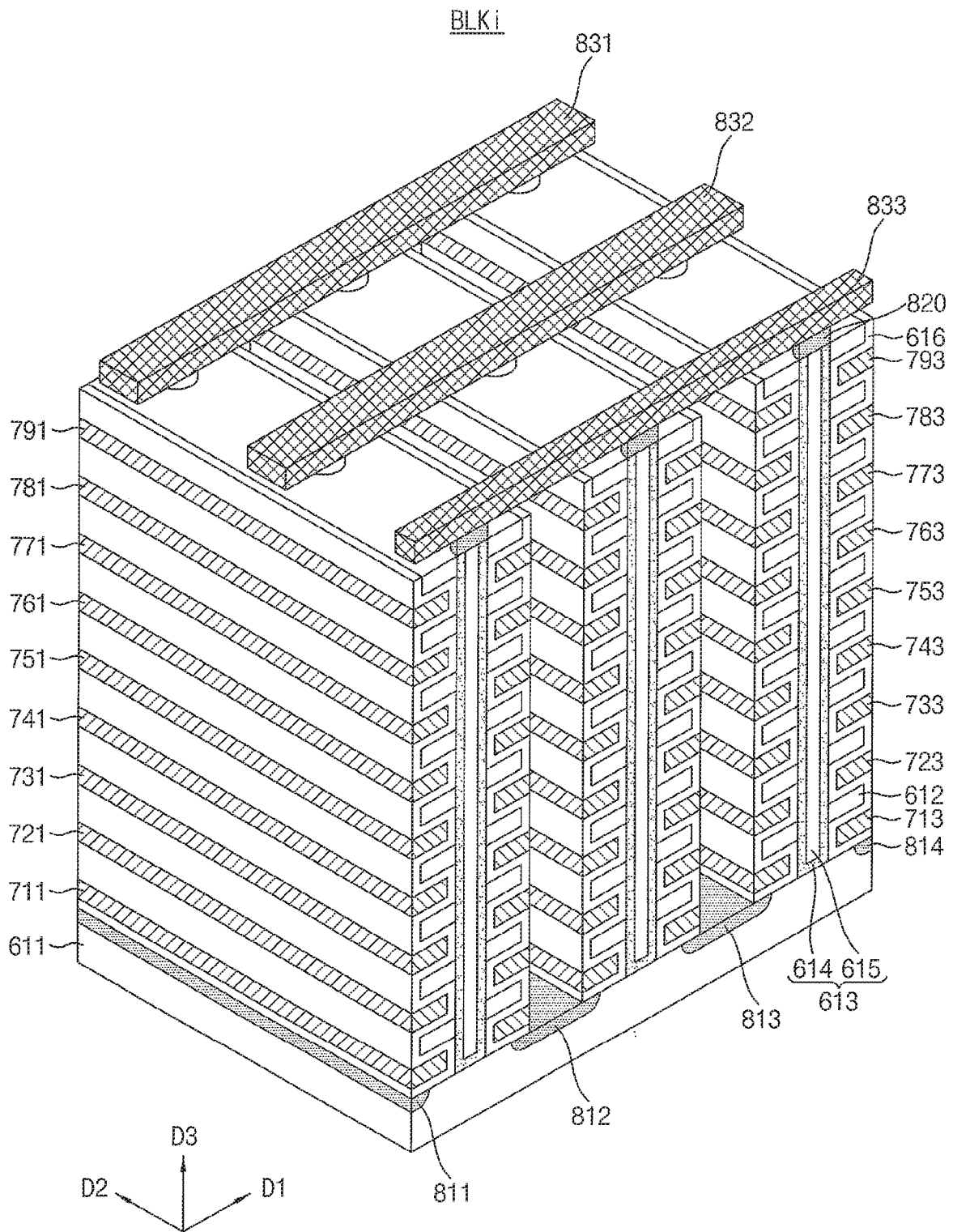


FIG. 16

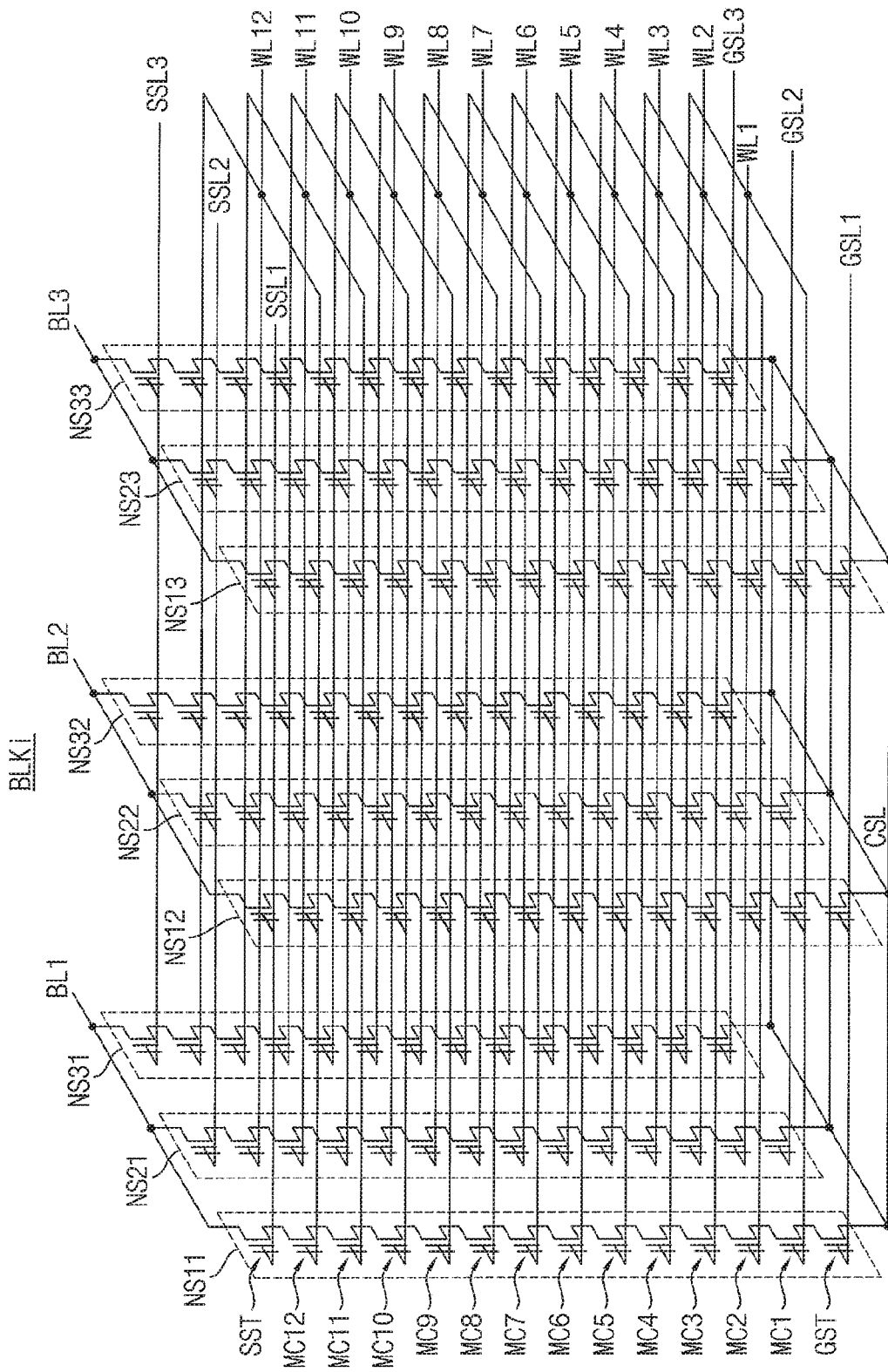


FIG. 17

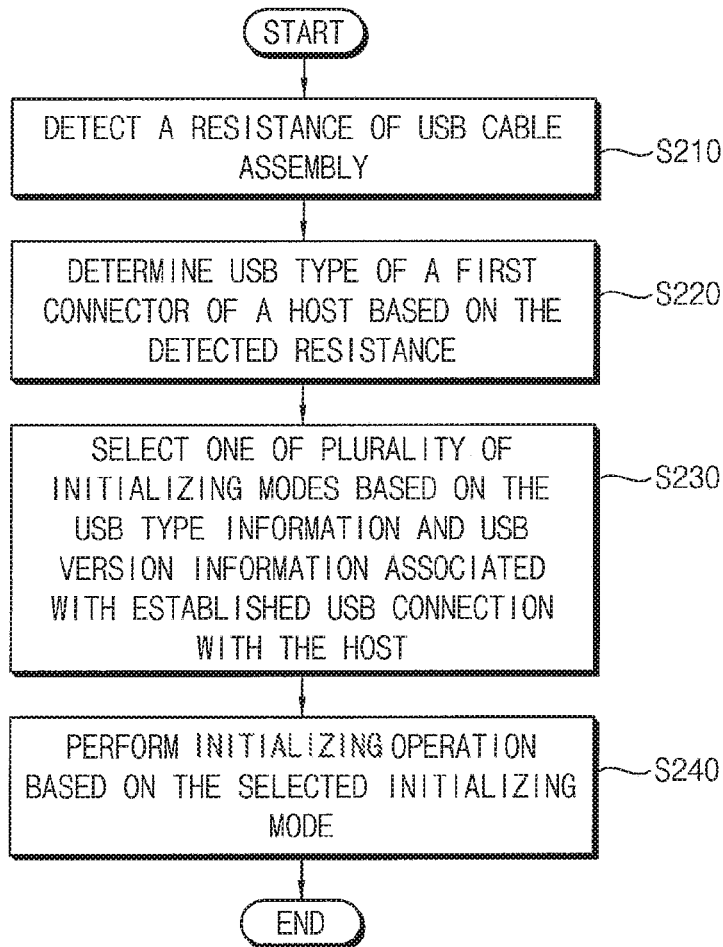
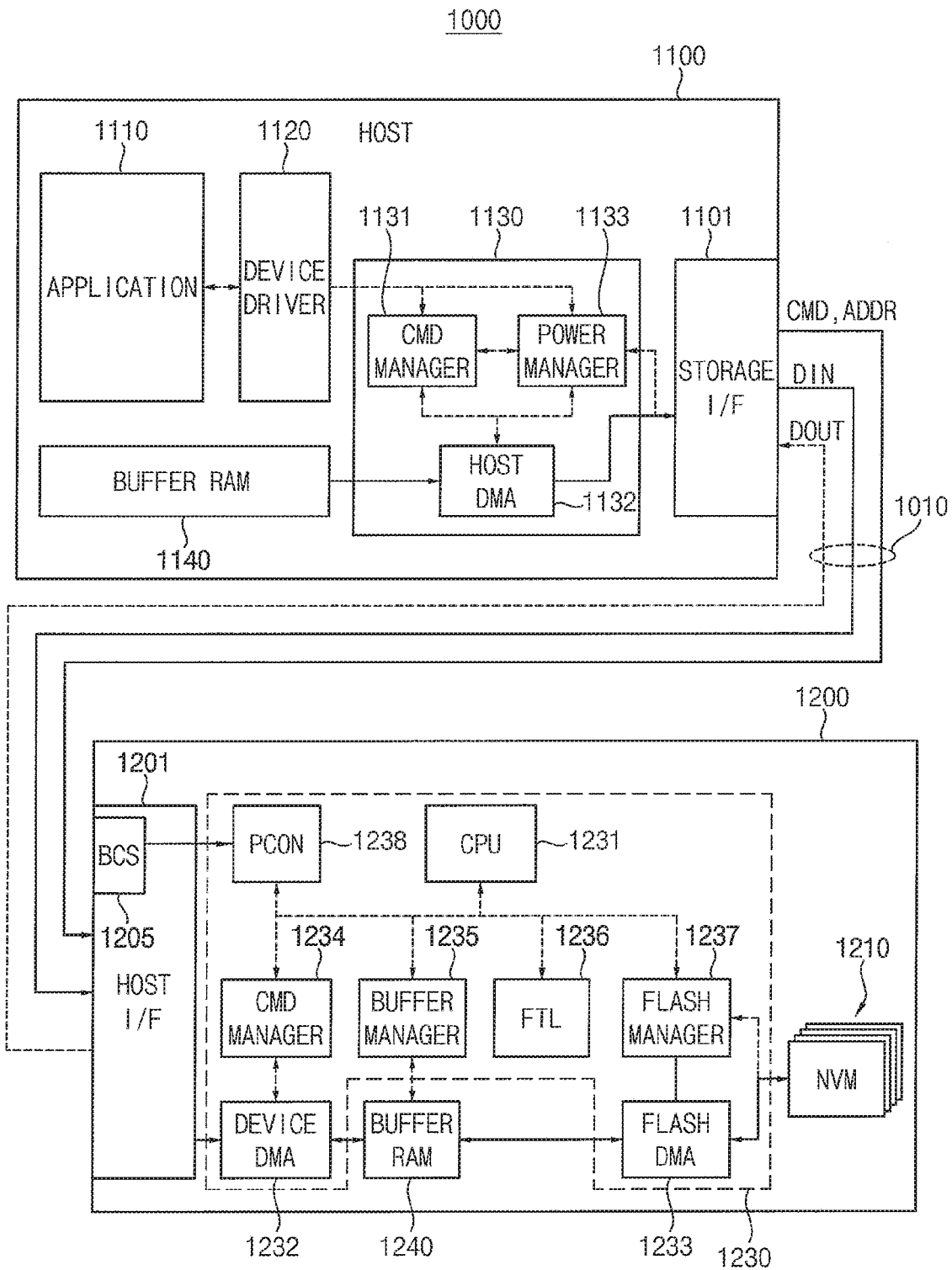


FIG. 18



**PORTABLE STORAGE DEVICES AND
METHODS OF OPERATING PORTABLE
STORAGE DEVICES**

**CROSS-REFERENCE TO RELATED
APPLICATIONS**

[0001] This application claims priority under 35 USC § 119 to Korean Patent Application No. 10-2019-0154141, filed on Nov. 27, 2019 in the Korean Intellectual Property Office (KIPO), the disclosure of which is incorporated by reference herein in its entirety.

TECHNICAL FIELD

[0002] Exemplary embodiments relate generally to storage devices, and more particularly, to portable storage devices and methods of operating portable storage devices.

DISCUSSION OF THE RELATED ART

[0003] A data transmission standard (e.g., universal serial bus (USB)) is an industrial data bus standard used to transmit digital data between electronic devices. A transmission speed of the USB 3.1 type that is currently being used is about ten times faster than that of the USB 2.0 type. Thus, the USB 3.1 type is commonly used to transmit high-definition content. A portable storage device may be connected to various hosts supporting various USB connectors.

SUMMARY

[0004] Exemplary embodiments provide a portable storage device capable of being compatible with various hosts and capable of performing power throttling.

[0005] Exemplary embodiments provide a method of operating a portable storage device capable of being compatible with various hosts and capable of performing power throttling.

[0006] According to exemplary embodiments, a portable storage device includes a plurality of nonvolatile memory devices configured to store data, a storage controller configured to control the plurality of nonvolatile memory devices, and a bridge chipset connected to a first connector of a host through a cable assembly. The bridge chipset is configured to detect a resistance of the cable assembly, provide the storage controller with universal serial bus (USB) type information of the first connector based on the detected resistance, and after a USB connection is established with the host, provide the storage controller with USB version information associated with the established USB connection. The storage controller, independently from the host, is configured to select one of a plurality of initializing modes based on the USB type information and the USB version information, select clock signals having frequencies in a range within a maximum power level associated with the selected initializing mode, and perform an initializing operation based on the selected clock signals within an internal reference time interval.

[0007] According to exemplary embodiments, a method of operating a portable storage device includes detecting, in a bridge chipset, a resistance of a cable assembly. The portable storage device includes a plurality of nonvolatile memory devices configured to store data, a storage controller configured to control the plurality of nonvolatile memory devices, and the bridge chipset connected to a first connector of a host through the cable assembly connected to a second

connector of the bridge chipset. The method further includes determining universal serial bus (USB) type information of the first connector based on the detected resistance, selecting, in the storage controller, one of a plurality of initializing modes based on the USB type information and USB version information associated with a USB connection established with the host, independently from the host, and performing power throttling based on the selected initializing mode.

[0008] According to exemplary embodiments, a portable storage device includes a plurality of nonvolatile memory devices configured to store data, a storage controller configured to control the plurality of nonvolatile memory devices, and a bridge chipset connected to a first connector of a host through a cable assembly. The bridge chipset is configured to detect a resistance of the cable assembly, provide the storage controller with universal serial bus (USB) type information of the first connector based on the detected resistance, and after a USB connection is established with the host, provide the storage controller with USB version information associated with the established USB connection. The bridge chipset includes a connection detector configured to detect the resistance of the cable assembly via a first pin of a plurality of pins in a second connector of the portable storage device, in which the second connector is connected to the cable assembly. The storage controller includes an interface unit configured to perform interfacing between the host and the nonvolatile memory devices, and a power controller configured to select one of a plurality of initializing modes based on the USB type information and the USB version information to perform an initializing operation. The bridge chipset is configured to provide the USB type information to the storage controller through a first general purpose input/output (GPIO) pin of the connection detector, in which the first GPIO pin is hard-wired to a second GPIO pin of the storage controller, and write the USB version information in a register in a peripheral component interconnect express (PCIe) interface in the interface unit. The power controller is further configured to select clock signals having frequencies in a range within a maximum power level associated with the selected initializing mode, and perform the initializing operation based on the selected clock signals within an internal reference time interval.

[0009] According to exemplary embodiments, a portable storage device includes a plurality of nonvolatile memory devices configured to store data, a storage controller configured to control the plurality of nonvolatile memory devices, and a bridge chipset connected to a first connector of a host through a cable assembly. The bridge chipset is configured to detect a resistance of the cable assembly, provide the storage controller with connection information of the first connector based on the detected resistance, and after a connection is established with the host, provide the storage controller with version information associated with the established connection. The storage controller, independently from the host, is configured to select one of a plurality of initializing modes based on the connection information and the version information, select clock signals having frequencies in a range within a maximum power level associated with the selected initializing mode, and perform an initializing operation based on the selected clock signals within an internal reference time interval.

[0010] Accordingly, in exemplary embodiments, the portable storage device may reduce a time interval of an

initializing operation and may optimize power by adaptively controlling power based on the USB type of the first connector of the host, connected through the cable assembly, and USB version information between the portable storage device and the host. In addition, the portable storage device may improve performance by controlling frequencies of the clock signals in a starting stage of the initializing operation.

BRIEF DESCRIPTION OF THE DRAWINGS

[0011] The above and other features of the present disclosure will become more apparent by describing in detail exemplary embodiments thereof with reference to the accompanying drawings, in which:

[0012] FIG. 1 is a block diagram illustrating a storage system according to exemplary embodiments.

[0013] FIG. 2 illustrates an example of a cable assembly in FIG. 1 according to exemplary embodiments.

[0014] FIG. 3A illustrates a first connector in FIG. 1 according to exemplary embodiments.

[0015] FIG. 3B illustrates a plug in FIG. 2 according to exemplary embodiments.

[0016] FIG. 3C is a table illustrating types of a cable assembly in FIG. 1 according to exemplary embodiments.

[0017] FIG. 4 is a block diagram illustrating a host in FIG. 1 according to exemplary embodiments.

[0018] FIG. 5 is a block diagram illustrating an example of a portable storage device in FIG. 1 according to exemplary embodiments.

[0019] FIG. 6 is a block diagram illustrating an example of a storage controller in FIG. 5 according to exemplary embodiments.

[0020] FIG. 7 illustrates an example of an interface unit in the storage controller of FIG. 6 according to exemplary embodiments.

[0021] FIG. 8 illustrates an example of a power controller in the storage controller of FIG. 6 according to example embodiments.

[0022] FIG. 9 illustrates an example of a look-up table (LUT) in FIG. 8 according to exemplary embodiments.

[0023] FIG. 10 illustrates an operation of a storage controller in FIG. 5 according to exemplary embodiments.

[0024] FIG. 11 is a timing diagram illustrating an operation of a storage controller in FIG. 5 according to exemplary embodiments.

[0025] FIG. 12 illustrates an operation of a connection detector in FIG. 5 according to exemplary embodiments.

[0026] FIG. 13 is a block diagram illustrating one of a plurality of nonvolatile memory devices in the portable storage device in FIG. 5 according to exemplary embodiments.

[0027] FIG. 14 is a block diagram illustrating a memory cell array in FIG. 13 according to exemplary embodiments.

[0028] FIG. 15 is a perspective view illustrating one of a plurality of memory blocks of FIG. 14 according to exemplary embodiments.

[0029] FIG. 16 is an equivalent circuit diagram illustrating the memory block of FIG. 15 according to exemplary embodiments.

[0030] FIG. 17 is a flowchart illustrating a method of operating a portable storage device according to exemplary embodiments.

[0031] FIG. 18 is a block diagram illustrating a storage system according to exemplary embodiments.

DETAILED DESCRIPTION OF THE EXEMPLARY EMBODIMENTS

[0032] Exemplary embodiments of the present disclosure will be described more fully hereinafter with reference to the accompanying drawings. Like reference numerals may refer to like elements throughout the accompanying drawings.

[0033] It will be understood that the terms “first,” “second,” “third,” etc. are used herein to distinguish one element from another, and the elements are not limited by these terms. Thus, a “first” element in an exemplary embodiment may be described as a “second” element in another exemplary embodiment.

[0034] It should be understood that descriptions of features or aspects within each exemplary embodiment should typically be considered as available for other similar features or aspects in other exemplary embodiments, unless the context clearly indicates otherwise.

[0035] As used herein, the singular forms “a,” “an” and “the” are intended to include the plural forms as well, unless the context clearly indicates otherwise.

[0036] Herein, when one value is described as being about equal to another value or being substantially the same as or equal to another value, it is to be understood that the values are identical, the values are equal to each other within a measurement error, or if measurably unequal, are close enough in value to be functionally equal to each other as would be understood by a person having ordinary skill in the art. For example, the term “about” as used herein is inclusive of the stated value and means within an acceptable range of deviation for the particular value as determined by one of ordinary skill in the art, considering the measurement in question and the error associated with measurement of the particular quantity (i.e., the limitations of the measurement system). For example, “about” may mean within one or more standard deviations as understood by one of the ordinary skill in the art. Further, it is to be understood that while parameters may be described herein as having “about” a certain value, according to exemplary embodiments, the parameter may be exactly the certain value or approximately the certain value within a measurement error as would be understood by a person having ordinary skill in the art.

[0037] FIG. 1 is a block diagram illustrating a storage system according to exemplary embodiments.

[0038] Referring to FIG. 1, a storage system 10 may include a host 100 and a portable storage device 200.

[0039] The host 100 and the portable storage device 200 may be electrically connected to each other, and may communicate with each other, through a universal serial bus (USB) cable assembly 30. The USB cable assembly 30 may also be referred to as a cable assembly 30.

[0040] In exemplary embodiments, the host 100 may be connected to the cable assembly 30 through a first connector 110, and the portable storage device 200 may be connected to the cable assembly 30 through a second connector 210.

[0041] The host 100 may include at least one of, for example, a smartphone, a tablet personal computer (PC), a mobile phone, a video phone, an e-book reader, a desktop PC, a laptop computer, a netbook computer, a workstation, a server, a personal digital assistant (PDA), a portable multimedia player (PMP), an MP3 player, a medical device, a camera, or a wearable device.

[0042] In exemplary embodiments, the host 100 may include at least one of various medical devices such as, for example, diverse portable medical measuring devices (e.g.,

a blood sugar measuring device, a heartbeat measuring device, or a body temperature measuring device), a magnetic resource angiography (MRA) device, a magnetic resource imaging (MRI) device, a computed tomography (CT) device, an imaging device, or an ultrasonic device. In exemplary embodiments, the host **100** may include, for example, a navigation device, a global navigation satellite system (GNSS) receiver, an event data recorder (EDR), a flight data recorder (FDR), an automotive infotainment device, a sailing electronic device (e.g., a sailing navigation device or a gyro compass), avionics devices, security devices, vehicular head units, industrial or home robots, drones, automatic teller machines (ATMs), or point of sales (POS) devices.

[0043] The first connector **110** may also be referred to as a first receptacle, and the second connector **210** may also be referred to as a second receptacle.

[0044] The host **100** may provide a command CMD and an address ADDR to the portable storage device **200** through the cable assembly **30**, and may exchange data DTA with the portable storage device **200** through the cable assembly **30**.

[0045] In FIG. 1, the portable storage device **200** is illustrated as a solid state drive (SSD) device as an example. However, exemplary embodiments are not limited thereto. For example, according to exemplary embodiments, the portable storage device **200** may be any kind of portable storage device.

[0046] The portable storage device **200** may include a bridge chipset **220** (which may also be referred to herein as a bridge chipset circuit), a storage controller **300** (which may also be referred to herein as a storage controller circuit), and a storage media **400**. The storage media **400** may include a plurality of nonvolatile memory devices. The plurality of nonvolatile memory devices may be used as a storage medium of the portable storage device **200**.

[0047] In exemplary embodiments, each of the plurality of nonvolatile memory devices **400a~400k** (see FIG. 5) may include a flash memory or a vertical NAND memory device. The storage controller **300** may control each of the plurality of nonvolatile memory devices **400a~400k**.

[0048] When the bridge chipset **220** is connected to the first connector **110** of the host **100** through the cable assembly **30**, the bridge chipset **220** may receive power from the host **100** and may detect a resistance of the cable assembly **30**. In addition, the bridge chipset **220** may determine a USB type of the cable assembly **30** and/or the first connector **110** based on the detected resistance, and may provide the storage controller **300** with USB type information indicating the determined USB type.

[0049] The bridge chipset **220** may notify the USB type information of the storage controller **300** by selectively toggling a general purpose input/output (GPIO) pin based on the detected resistance.

[0050] In addition, when a USB connection of the portable storage device **200** with the host **100** is established (e.g., when a USB link is established between the host **100** and the portable storage device **200**), the bridge chipset **220** may provide the storage controller **300** with USB version information indicating USB protocol information between the host **100** and the portable storage device **200**.

[0051] The storage controller **300**, independently from the host **100**, may select one of a plurality of initializing modes based the USB type information and the USB version information, may select clock signals having frequencies in

a range within a maximum power level associated with the selected initializing mode, and may perform an initializing operation on the storage media **400** based on the selected clock signals within an internal reference time interval.

[0052] That is, the storage controller **300** may select frequencies of clock signals to be provided to hardware modules in the storage controller **300** such that a power target level associated with the selected initializing mode is not exceeded.

[0053] FIG. 2 illustrates an example of the cable assembly **30** in FIG. 1 according to exemplary embodiments.

[0054] Referring to FIG. 2, the cable assembly **30** may include a cable **31**, a first overmold **33**, a second overmold **33-1**, a first plug **35** and a second plug **35-1**.

[0055] The first plug **35** may be connected to the cable **31** through the first overmold **33**, and the second plug **35-1** may be connected to the cable **31** through the second overmold **33-1**.

[0056] FIG. 3A illustrates the first connector **110** in FIG. 1 according to exemplary embodiments. FIG. 3B illustrates a plug in FIG. 2 according to exemplary embodiments.

[0057] Referring to FIG. 3A, the first connector **110**, which can be connected to the first plug **35**, may include 24 pins A1 to A12 and B1 to B12. Pins may also be referred to as contacts.

[0058] A first group of pins A1 to A12 may be disposed symmetrically with a second group of pins B1 to B12 with respect to a center portion of the first plug **35**.

[0059] For example, the first connector **110** may include first GND pins A1, A12, B1, and B12, first USB 3.1 transmitter pins A2, A3, B2, and B3, first USB 3.1 receiver pins A10, A11, B10, and B11, first VBUS pins A4, A9, B4, and B9, first CC pins A5 and B5, first USB 2.0 signal pins A6, A7, B6, and B7, and first side pins A8 and B8.

[0060] Referring to FIG. 3B, the first plug **35** or the second plug **35-1** may include 24 pins A1 to A12 and B1 to B12 corresponding to respective pins of the first connector **110**.

[0061] For example, the first plug **35** or the second plug **35-1** may include second GND pins A1, A12, B1, and B12, second USB 3.1 transmitter pins A2, A3, B2, and B3, second USB 3.1 receiver pins A10, A11, B10, and B11, second VBUS pins A4, A9, B4, and B9, a second CC pin A5, a VCONN pin B5, second USB 2.0 signal pins A6 and A7, and second side pins A8 and B8.

[0062] The first USB 3.1 transmitter pins A2, A3, B2, and B3 of the first connector **110** may be connected to the first USB 3.1 transmitter pins A2, A3, B2, and B3 of the first plug **35**, and the first USB 3.1 receiver pins A10, A11, B10, and B11 of the first connector **110** may be connected to the second USB 3.1 transmitter pins A2, A3, B2, and B3 of the first plug **35**, thereby transmitting or receiving data between the first connector **110** and the first plug **35** or the second plug **35-1** according to the USB 3.1 protocol. Each of the first CC pins A5 and B5 of the first connector **110** may be connected to the second CC pin A5 or the VCONN pin B5 of the first plug **35** or the second plug **35-1**.

[0063] Configurations of the first connector **110** and the first plug **35** or the second plug **35-1** are examples according to USB type-C. Configurations of the first connector **110** and the first plug **35** or the second plug **35-1** may be changed according to the USB type.

[0064] In exemplary embodiments, pin assignment of the second connector **210** may be the same as or similar with the pin assignment of the first connector **110**.

[0065] In exemplary embodiments, the host 100 supporting the USB interface may define insertion direction of the first plug 35 connected to the first connector 110, and whether the portable storage device 200 connected to the first connector 110 through the cable assembly 30 operates as a USB device or as a USB host, by measuring a voltage of the CC pin (identification pin) of the host 100.

[0066] That is, the CC (CC1 or CC2) pin may be used for at least one of detecting connection of the portable storage device 200 through the cable assembly 30, determining the insertion direction of the first plug 35, and managing a configuration of the storage system 10 (e.g., managing a configuration of the host 100 and the portable storage device 200).

[0067] As such, to recognize the insertion direction of the first plug 35 and to define whether the external device connected to the first connector 110 and the cable assembly 30 is the USB device or the USB host by measuring the voltage of the CC pin, a specified current may always be applied to the CC pin. The specified current, which may be supplied by the host 100, may be varied according to the USB type of the first connector 110.

[0068] FIG. 3C is a table illustrating types of the cable assembly in FIG. 1 according to exemplary embodiments.

[0069] Referring to FIG. 3C, the (USB) type of the cable assembly 30 complies with "TYPE C to C" as reference numeral 36 indicates, complies with "TYPE C to STANDARD A" as reference numeral 37 indicates, or complies with "TYPE C to RECEPTACLE B" as reference numeral 38 indicates.

[0070] In exemplary embodiments, the cable assembly 30 in FIG. 1 does not comply with a USB type. In this case, the bridge chipset 220 may detect a resistance of the cable assembly 30, may provide the storage controller 300 with connection information of the first connector 110 based on the detected resistance, and after a connection is established with the host 100, may provide the storage controller 300 with version information associated with the established connection. The storage controller 300, independently from the host 100, may select one of a plurality of initializing modes based on the connection information and the version information, may select clock signals having frequencies in a range within a maximum power level associated with the selected initializing mode, and may perform an initializing operation based on the selected clock signals within an internal reference time interval.

[0071] FIG. 4 is a block diagram illustrating the host 100 in FIG. 1 according to exemplary embodiments.

[0072] Referring to FIG. 4, the host 100 may include a central processing unit (CPU) 120, a read-only memory (ROM) 125, a main memory 130, a storage interface 140, a user interface 150, and a bus 160.

[0073] The bus 160 may refer to a transmission channel via which data is transmitted between the CPU 120, the ROM 125, the main memory 130, the storage interface 140, and the user interface 150 of the host 100.

[0074] The ROM 125 may store various application programs. For example, application programs supporting storage protocols such as Advanced Technology Attachment (ATA), Small Computer System Interface (SCSI), embedded Multi Media Card (eMMC), and/or Unix File System (UFS) protocols may be stored.

[0075] The main memory 130 may temporarily store data or programs.

[0076] The user interface 150 may be a physical or virtual medium for exchanging information between a user and the host 100, a computer program, etc., and may include physical hardware and logical software. For example, the user interface 150 may include an input device for allowing the user to manipulate the host 100, and an output device for outputting a result of processing an input of the user.

[0077] The CPU 120 may control overall operations of the host 100. The CPU 120 may generate a command for storing data in the portable storage device 200 or a request (or a command) for reading data from the portable storage device 200 by using an application stored in the ROM 125, and may transmit the request to the portable storage device 200 via the storage interface 140.

[0078] FIG. 5 is a block diagram illustrating an example of the portable storage device 200 in FIG. 1 according to exemplary embodiments.

[0079] Referring to FIG. 5, the portable storage device 200 may include a second connector 210 connected to the cable assembly 30, the bridge chipset 220, the storage controller 300 and the storage media 400.

[0080] The storage media 400 may include a plurality of nonvolatile memory devices 400a~400k (where k is an integer greater than two). The storage controller 300 may be connected to the plurality of nonvolatile memory devices 400a~400k through a plurality of channels CHG1~CHGk (where k is an integer greater than two), respectively.

[0081] The second connector 210 may include a plurality of pins, and the plurality of pins may include a cable bus power (VBUS) pin 211 for supplying power, CC1 and CC2 pins 212 and 213 for exchanging setting information with the host 100, and a ground (GND) pin 214.

[0082] The bridge chipset 220 may be connected to the second connector 210. The bridge chipset 220 may include an interface converter 230 (which may also be referred to herein as an interface converter circuit) and a connection detector 240 (which may also be referred to herein as a connection detector circuit).

[0083] The interface converter 230 may perform interface converting between the host 100 and the storage controller 300. For example, the interface converter 230 may convert an interface of the host 100 to an interface conformed to the plurality of nonvolatile memory devices 400a~400k, or may convert an interface conformed to the plurality of nonvolatile memory devices 400a~400k to an interface of the host 100.

[0084] The connection detector 240 is connected to the CC1 pin 212, detects a resistance of the cable assembly 30 and the first connector 110 in response to power being applied to the cable assembly 30 when the cable assembly 30 is connected to the first connector 110 of the host 100, determines a USB type of the cable assembly 30 and the first connector 110 based on the detected resistance, and provides the storage controller 300 with USB type information UTI indicating the USB type of the cable assembly 30 and the first connector 110.

[0085] When the cable assembly 30 is connected to the first connector 110 of the host 100 and power is applied to the cable assembly 30, a specified current applied to the CC1 pin of the first connector 110 is provided to the CC1 pin 212 through the cable assembly 30, and a voltage based on the current is induced at the CC1 pin 212. The connection

detector **240** may detect the resistance of the cable assembly **30** and the first connector **110** by detecting a voltage of the CC1 pin **212**.

[0086] The connection detector **240** may determine the USB type of the cable assembly **30** and the first connector **110** based on a comparison of the detected resistance with a threshold value. In exemplary embodiments, when the detected resistance is smaller than or equal to the threshold value, the connection detector **240** may determine the USB type of the first connector **110** as USB type-C, and when the detected resistance is greater than the threshold value, the connection detector **240** may determine the USB type of the first connector **110** as USB type-A.

[0087] In exemplary embodiments, the connection detector **240** may provide the USB type information UTI to a power controller **360** of the storage controller **300** through a first GPIO pin **221**. The connection detector **240** may selectively toggle a voltage of the first GPIO pin **221** based on the detected resistance. In exemplary embodiments, the bridge chipset **220** may provide the power controller **360** with the USB type information UTI as a side-band signal by selectively toggling the first GPIO pin **221**, and the bridge chipset **220** may write the USB version information in a register **352**, which is described further below, as an in-band signal.

[0088] When the detected resistance is smaller than or equal to the threshold value, the connection detector **240** may notify the storage controller **300** of the USB type of the first connector **110** being USB type-C by maintaining the voltage level of the first GPIO pin **221** at a first level.

[0089] When the detected resistance is greater than the threshold value, the connection detector **240** may notify the storage controller **300** of the USB type of the first connector **110** being USB type-C by toggling the voltage of the first GPIO pin **221** from the first level to a second level.

[0090] The storage controller **300** may include the power controller **360** (which may also be referred to herein as a power controller circuit) and an interface unit **350** (which may also be referred to herein as an interface circuit). The interface unit **350** may include the register **352**. The register **352** may be a vendor specific register (VSR).

[0091] The power controller **360** may be connected to a second GPIO pin **301** of the storage controller **300**. The second GPIO pin **301** may be hard-wired connected to the first GPIO pin **221** through a wire **290**.

[0092] After the connection is established with the host **100**, the connection detector **240** may provide the storage controller **300** with USB version information UVI associated with the established connection.

[0093] The connection detector **240** may write the USB version information UVI in the register **352** and may obtain the USB version information UVI by referring to the register **352** in response to a write event in the register **352**. The bridge chipset **220** and the storage controller **300** may communicate with each other via side-band communication through the first GPIO pin **221** and the second GPIO pin **301**, respectively. The connection detector **240** and the register **352** in the interface unit **350** may communicate with each other via in-band communication and through a non-non-volatile memory express (NVMe) interface.

[0094] The power controller **360** may select one of a plurality of initializing modes based on the USB type information UTI and the USB version information UVI, and may perform an initializing operation based on selected

clock signals having frequencies in a range within a maximum power level associated with the selected initializing mode.

[0095] FIG. 6 is a block diagram illustrating an example of the storage controller **300** in FIG. 5 according to exemplary embodiments.

[0096] Referring to FIG. 6, the storage controller **300** may include a processor **310**, an error correction code (ECC) engine **320** (which may also be referred to herein as an ECC engine circuit), a buffer **330** (which may also be referred to herein as a buffer circuit), a randomizer **335** (which may also be referred to herein as a randomizer circuit), a ROM **340**, an interface unit **350** (which may also be referred to herein as an interface circuit), a power controller **360** (which may also be referred to herein as a power controller circuit), and a nonvolatile controller **345** (which may also be referred to herein as a nonvolatile controller circuit), which are connected to one another via a bus **305**.

[0097] The processor **310** controls an overall operation of the storage controller **300**. The processor **310** may include a plurality of cores.

[0098] The plurality of cores may perform control operations associated with the nonvolatile memory devices **400a-400k**. At least one of the plurality of cores may process a command provided from the host **100**, at least one of the plurality of cores may perform address mapping and garbage collection using a flash translation layer (FTL), and at least one of the plurality of cores may control the nonvolatile memory devices **400a-400k** through the non-volatile controller **345**.

[0099] Memory cells of the nonvolatile memory devices **400a-400k** may have the physical characteristic that a threshold voltage distribution varies due to causes, such as, for example, a program elapsed time, a temperature, program disturbance, read disturbance, etc. For example, data stored in the nonvolatile memory devices **400a-400k** may become corrupt due to the above causes.

[0100] The storage controller **300** utilizes a variety of error correction techniques to correct such errors. For example, the storage controller **300** may include the ECC engine **320**. The ECC engine **320** may correct errors which occur in the data stored in the nonvolatile memory devices **400a-400k**.

[0101] The ROM **340** stores a variety of information used for the storage controller **300** to operate, in firmware. The buffer **330** may store data provided from the nonvolatile memory devices **400a-400k**.

[0102] The randomizer **335** randomizes data to be stored in the nonvolatile memory devices **400a-400k**. For example, the randomizer **335** may randomize data to be stored in the nonvolatile memory devices **400a-400k** in a unit of a word line.

[0103] Data randomizing may be performed to process data such that program states of memory cells connected to a word line have the same ratio.

[0104] For example, if memory cells connected to one word line are multi-level cells (MLC) each storing 2-bit data, each of the memory cells has one of an erase state and first through third program states.

[0105] In this case, the randomizer **335** may randomize data such that in memory cells connected to one word line, the number of memory cells having the erase state, the number of memory cells having the first program state, the number of memory cells having the second program state, and the number of memory cells having the third program

state are the same as or substantially the same as one another. For example, memory cells in which randomized data is stored have program states of which the number is equal to one another.

[0106] The randomizer 335 further de-randomizes data read from the nonvolatile memory devices 400a~400k.

[0107] The interface unit 350 may perform interfacing between the host 100 and the nonvolatile memory devices 400a~400k.

[0108] The interface unit 350 includes the register 352, and the register 352 may store the USB version information UVI.

[0109] The power controller 360 may receive the USB type information UTI, may select one of a plurality of initializing modes based on the USB type information UTI and the USB version information UVI, and may perform power throttling to adjust the power level consumed in the initializing operation associated with the selected initializing mode.

[0110] The nonvolatile controller 345 may receive the command CMD and the address ADDR, and may control the nonvolatile memory devices 400a~400k based on the command CMD and the address ADDR.

[0111] FIG. 7 illustrates an example of the interface unit 350 in the storage controller 300 of FIG. 6 according to exemplary embodiments.

[0112] Referring to FIG. 7, the interface unit 350 may include a peripheral component interconnect express (PCIe) interface 351, a nonvolatile memory express (NVMe) interface 353, and an interface controller 355. The PCIe interface 351 may include the register 352.

[0113] The interface controller 355 may control the PCIe interface 351 and the NVMe interface 353.

[0114] The PCIe interface 351 may be a communication path through which commands and data are transmitted and received according to a PCIe protocol. The NVMe interface 353 may be a communication path through which commands and data are transmitted and received according to an NVMe protocol. The NVMe protocol may be supported by the PCIe protocol. Therefore, the NVMe interface 353 may transmit/receive the commands and the data via the PCIe interface 351.

[0115] FIG. 8 illustrates an example of the power controller 360 in the storage controller 300 of FIG. 6 according to exemplary embodiments.

[0116] Referring to FIG. 8, the power controller 360 may include a control logic 361 (which may also be referred to herein as a control logic circuit), an initial mode look-up table (LUT) 370, a clock generator 380 (which may also be referred to herein as a clock generator circuit), and a selection circuit 390. The initial mode LUT 370 may also be referred to as an LUT or a power throttling LUT.

[0117] The clock generator 380 may include phase-locked loop (PLL) circuits 381 and 383, and the selection circuit 390 may include multiplexers 391, 392, 393 and 394.

[0118] In FIG. 8, the processor 310 including a plurality of cores 311, 312 and 313, and the nonvolatile controller 345, are also illustrated for convenience of explanation.

[0119] The core 311 may process a command provided from the host 100, the core 312 may perform address mapping and garbage collection using FTL, and the core 313 may control the nonvolatile memory devices 400a~400k through the nonvolatile controller 345.

[0120] The control logic 361 may access the LUT 370 based on the USB type information UTI and the USB version information UVI, and may generate selection signals SS1, SS2, SS3 and SS4 by referring to a corresponding power target.

[0121] The LUT 370 may store information on power targets associated with a plurality of initializing modes. In exemplary embodiments, the LUT 370 may store information on frequencies of clock signals provided to the cores 311, 312 and 313, the system bus 305, and the nonvolatile controller 345 in each of the plurality of initializing modes.

[0122] The PLL circuit 381 may generate a base clock signal CLK1 having a first frequency and divided clock signals CLKD11 and CLKD12 by dividing the base clock signal CLK1.

[0123] The PLL circuit 383 may generate a base clock signal CLK2 having a second frequency and divided clock signals CLKD21 and CLKD22 by dividing the base clock signal CLK2.

[0124] The multiplexer 391 may select one of the base clock signal CLK1 and the divided clock signals CLKD11 and CLKD12 as a first selected clock signal SCLK1 in response to a first selection signal SS1, and may provide the first selected clock signal SCLK1 to the cores 311 and 313.

[0125] The multiplexer 392 may select one of the base clock signal CLK1 and the divided clock signals CLKD11 and CLKD12 as a second selected clock signal SCLK2 in response to a second selection signal SS2, and may provide the second selected clock signal SCLK2 to the system bus 305.

[0126] The multiplexer 393 may select one of the base clock signal CLK2 and the divided clock signals CLKD21 and CLKD22 as a third selected clock signal SCLK3 in response to a third selection signal SS3, and may provide the third selected clock signal SCLK3 to the core 312.

[0127] The multiplexer 394 may select one of the base clock signal CLK2 and the divided clock signals CLKD21 and CLKD22 as a fourth selected clock signal SCLK4 in response to a fourth selection signal SS4, and may provide the fourth selected clock signal SCLK4 to the nonvolatile controller 345.

[0128] FIG. 9 illustrates an example of the LUT 370 in FIG. 8 according to exemplary embodiments.

[0129] Referring to FIG. 9, the LUT 370 may include entries 371, 372 and 373 corresponding to the plurality of initializing modes. The entry 371 may store a second power target HIGH associated with USB type-C, the entry 372 may store a third power target MIDDLE associated with USB type-A and USB version 3.0 higher, and entry 372 may store a first power target LOW associated with USB type-A and USB version 2.0.

[0130] The first through third power targets LOW, MIDDLE and HIGH may include information on operating frequencies of the clock signals provided to hardware elements such as the cores 311, 312 and 313, the system bus 305, and the nonvolatile controller 345 according to the USB type information of the first connector 110 and/or the cable assembly 30 and the USB version information of the first connector 110 and/or the cable assembly 30.

[0131] For example, the second power target HIGH may include information on operating frequencies of the clock signals provided to the cores 311, 312 and 313, the system bus 305, and the nonvolatile controller 345 when the USB type of the first connector 110 corresponds to USB type-C.

[0132] For example, the third power target MIDDLE may include information on operating frequencies of the clock signals provided to the cores 311, 312 and 313, the system bus 305, and the nonvolatile controller 345 when the USB type of the first connector 110 corresponds to USB type-A and the USB version associated with the established connection corresponds to USB 3.0 or higher.

[0133] For example, the first power target LOW may include information on operating frequencies of the clock signals provided to the cores 311, 312 and 313, the system bus 305, and the nonvolatile controller 345 when the USB type of the first connector 110 corresponds to USB type-A and the USB version associated with the established connection corresponds to USB 2.0.

[0134] The control logic 361 may generate the selection signals SS1, SS2, SS3 and SS4 by referring to information of operating frequencies of the clock signals associated with each of the power targets, and may provide the selection signals SS1, SS2, SS3 and SS4 to the multiplexers 391, 392, 393 and 394.

[0135] FIG. 10 illustrates an operation of the storage controller 300 in FIG. 5 according to exemplary embodiments.

[0136] Referring to FIGS. 5 through 10, in exemplary embodiments, when power is applied to the portable storage device 200, the power controller 360 performs an initializing operation by setting a power target as the first power target corresponding to a default value (S110). The power controller 360 selects a first initializing mode corresponding to the first power target of the plurality of initializing modes. Because the power controller 360 cannot obtain the USB type information of the first connector 110 and the USB version information associated with the established connection at an instance when the power is applied to the portable storage device 200, the power controller 360 performs the initializing operation by setting the first power target of a plurality of power targets. The first power target may have a minimum power level from among the plurality of power targets.

[0137] The connection detector 240 in the bridge chipset 220 detects a resistance of the cable assembly 30 by detecting a voltage of the CC1 pin 212 (S120). The connection detector 240 determines whether the voltage of the CC1 pin 212 is smaller than or equal to a threshold value based on a comparison of the voltage of the CC1 pin 212 with the threshold value (S130).

[0138] When the voltage of the CC1 pin 212 is smaller than the threshold value (YES in S130), the USB type of the cable assembly 30 is USB type-C and the power controller 360 performs an initializing operation by setting the power target as the second power target (HIGH) (S140). The power controller 360 selects a second initializing mode corresponding to the second power target of the plurality of initializing modes. The second power target may have a maximum power level from among the plurality of power targets.

[0139] When the voltage of the CC1 pin 212 is greater than the threshold value (NO in S130), the USB type of the cable assembly 30 is USB type-A, and thus the connection detector 240 determines whether the USB version information (e.g., the USB link) corresponds to USB 3.0 or higher (S150).

[0140] When the USB version information corresponds to USB 3.0 or higher (YES in S150), the power controller 360 performs an initializing operation by setting the power target

as the third power target (MIDDLE) (S160). The power controller 360 selects a third initializing mode corresponding to the third power target of the plurality of initializing modes. The third power target may have a power level greater than the minimum power level and smaller than the maximum power level, and thus, the third power target may also be referred to as an intermediate or middle power target.

[0141] When the USB version information does not correspond to USB 3.0 or higher (NO in S150), the power controller 360 maintains the first initializing mode.

[0142] FIG. 11 is a timing diagram illustrating an initializing operation of the storage controller 300 in FIG. 5 according to exemplary embodiments.

[0143] Referring to FIGS. 5 through 9 and 11, when power is applied to the portable storage device 200 at a first time point T11, the connection detector 240 detects a resistance of the cable assembly 30 by detecting the voltage of the CC1 pin 212 to determine a USB type of the cable assembly 30. The USB type of the cable assembly 30 may be detected at a second time point T12.

[0144] When the USB type of the cable assembly 30 corresponds to USB type-C as reference numeral 375 indicates, open operation is done at a fourth time point T14. In this case, the power target is set to the second power target (HIGH).

[0145] The connection detector 240 detects USB version information of the cable assembly at a third time point T13.

[0146] When the USB type of the cable assembly 30 corresponds to USB type-A and the USB version information of the cable assembly 30 corresponds to USB 3.0 higher as reference numeral 376 indicates, open operation is done at a fifth time point T15. In this case, the power target is set to the third power target (MIDDLE).

[0147] When the USB type of the cable assembly 30 corresponds to USB type-A and the USB version information of the cable assembly 30 corresponds to USB 2.0 as reference numeral 377 indicates, open operation is done at a sixth time point T16. In this case, the power target is set to the first power target (LOW).

[0148] FIG. 12 illustrates an operation of the connection detector 240 in FIG. 5 according to exemplary embodiments.

[0149] Referring to FIGS. 5 through 9 and 12, power is applied to the portable storage device 200 at a first time point T21.

[0150] The bridge chipset 220 (the connection detector 240) operates to maintain a voltage of the first GPIO pin 221 with a first level (high level) during a first time interval INT11 from a second time point T22 to a fourth time point T24 after the power is applied. At a third time point T23 in the first time interval INT11, reset of the storage controller 300 is released, and the storage controller 300 starts to operate. The bridge chipset 220 changes the voltage level of the first GPIO pin 221 to a second level different from the first level at the fourth time point T24, maintains the voltage level of the first GPIO pin 221 with the second logic level (low level) during a second time interval INT12 from the fourth time point T24 to a fifth time point T25, and changes the voltage level of the first GPIO pin 221 to the first logic level at the fifth time point T25.

[0151] The power controller 360 prepares for detecting a voltage of the second GPIO pin 301 in response to the voltage of the second GPIO pin 301 changing to the first level at the fifth time point T25, and the power controller 360

determines the USB type of the cable assembly 30 based on the voltage level of the second GPIO pin 301 after the third time interval INT13 from the fifth time point T25 to a sixth time point T26 elapses.

[0152] When the voltage of the CC1 pin 212 is smaller than or equal to the threshold value, the connection detector 240 may notify the storage controller 300 of the USB type of the first connector 110 being USB type-C by maintaining the voltage level of the first GPIO pin 221 with the first level during the third time interval INT13.

[0153] When the voltage of the CC1 pin 212 is greater than the threshold value, the connection detector 240 may notify the storage controller 300 of the USB type of the first connector 110 being USB type-A by changing the voltage level of the first GPIO pin 221 to the second level and maintaining the voltage level of the first GPIO pin 221 with the second level during the third time interval INT13.

[0154] During a fourth time interval INT14 from a seventh time point T27 to an eighth time point T28, the connection detector 240 changes or maintains the voltage level of the first GPIO pin 221 to or at the second level, changes the voltage level of the first GPIO pin 221 to the first logic level, and writes the USB version information UVI in the register 352 in the PCIe interface 351 at the eighth time point T28. The storage controller 300 determines the USB version of the first connector 110 in response to a write event in the register 352 at a ninth time point T29. That is, the connection detector 240 may notify the storage controller 300 of the USB type of the first connector 110 and/or the cable assembly 30 by changing the voltage level of the first GPIO pin 221 to the first level or by maintaining the voltage level of the first GPIO pin 221 at the second level during the third time interval INT13.

[0155] A time interval from a time point when the power is applied to the ninth time point T29 may correspond to an interval reference time interval and the internal reference time interval may be smaller than or equal to 10 seconds.

[0156] FIG. 13 is a block diagram illustrating one of the nonvolatile memory devices 400a in the portable storage device 200 in FIG. 5 according to exemplary embodiments. For convenience of illustration, FIG. 13 illustrates only the nonvolatile memory device 400a. In exemplary embodiments, each of the nonvolatile memory devices 400a~400k in the portable storage device 200 in FIG. 5 may have the configuration shown in FIG. 13.

[0157] Referring to FIG. 13, the nonvolatile memory device 400a includes a memory cell array 430, an address decoder 460, a page buffer circuit 410, a data input/output circuit 420, a control circuit 450, and a voltage generator 470.

[0158] The memory cell array 430 may be coupled to the address decoder 460 through a string selection line SSL, a plurality of word lines WLs, and a ground selection line GSL. In addition, the memory cell array 430 may be coupled to the page buffer circuit 410 through a plurality of bit lines BLs. The memory cell array 430 may include a plurality of memory cells coupled to the plurality of word lines WLs and the plurality of bit lines BLs. The memory cell array 430 may include a plurality of memory cells coupled to the plurality of word lines WLs stacked in a vertical direction, which is perpendicular to a substrate.

[0159] FIG. 14 is a block diagram illustrating the memory cell array 430 in FIG. 13 according to exemplary embodiments.

[0160] Referring to FIG. 14, the memory cell array 430 may include a plurality of memory blocks BLK1 to BLKz (where z is an integer greater than two). In an exemplary embodiment, the memory blocks BLK1 to BLKz are selected by the address decoder 460 in FIG. 13. For example, the address decoder 460 may select a memory block BLK corresponding to a block address among the memory blocks BLK1 to BLKz.

[0161] FIG. 15 is a perspective view illustrating one of the memory blocks BLK1 to BLKz of FIG. 14 according to exemplary embodiments. In exemplary embodiments, each of the memory blocks BLK1 to BLKz of FIG. 14 may have the configuration of the memory block BLKi shown in FIG. 15.

[0162] Referring to FIG. 15, a memory block BLKi includes structures extending along the first to third directions D1~D3.

[0163] A substrate 611 is provided. For example, the substrate 611 may have a well of a first type (e.g., a first conductive type). For example, the substrate 611 may have a p-well formed by implanting a group 3 element such as boron (B). A plurality of doping regions 811 to 814 extending along the first direction D1 are provided in/on the substrate 611. For example, the plurality of doping regions 811 to 814 may have a second type (e.g., a second conductive type) different from the first type of the substrate 611. In an exemplary embodiment, the first to fourth doping regions 811 to 814 have an n-type.

[0164] A plurality of insulation materials 612 extending along the second direction D2 are sequentially provided along the third direction D3 in a region of the substrate 611 between the first and second doping regions 811 and 812. For example, the plurality of insulation materials 612 may be provided along the third direction D3 and spaced by a specific distance. Exemplarily, the insulation materials 612 may include an insulation material such as an oxide layer. However, the insulation materials 612 are not limited thereto.

[0165] A plurality of pillars 613 penetrating the insulation materials 612 along the third direction D3 are sequentially disposed along the second direction D2 in a region of the substrate 611 between the first and second doping regions 811 and 812. For example, the plurality of pillars 613 may penetrate the insulation materials 612 to contact the substrate 611.

[0166] For example, each pillar 613 may include a plurality of materials. For example, a channel layer 614 of each pillar 613 may include a silicon material having a first type. For example, the channel layer 614 of each pillar 613 may include a silicon material having the same type as the substrate 611. In an exemplary embodiment, the channel layer 614 of each pillar 613 includes a p-type silicon. An internal material 615 of each pillar 613 includes an insulation material. For example, the internal material 615 of each pillar 613 may include an insulation material such as a silicon oxide. However, the internal material 615 is not limited thereto. For example, the internal material 615 of each pillar 613 may include an air gap.

[0167] An insulation layer 616 is provided along the exposed surfaces of the insulation materials 612, the pillars 613, and the substrate 611, in a region between the first and second doping regions 811 and 812. Exemplarily, the insu-

lation layer **616** provided on the exposed surface in the third direction **D3** of the last insulation material **612** may be removed.

[0168] A plurality of first conductive materials **711** to **791** is provided between the second doping regions **811** and **812** on the exposed surfaces of the insulation layer **616**. For example, the first conductive material **711** extending along the second direction **D2** is provided between the substrate **611** and the insulation material **612** adjacent to the substrate **611**.

[0169] A first conductive material extending along the first direction **D1** is provided between the insulation layer **616** at the top of a specific insulation material among the insulation materials **612** and the insulation layer **616** at the bottom of a specific insulation material **612** among the insulation materials **612**. For example, a plurality of first conductive materials **721** to **781** extending along the first direction **D1** are provided between the insulation materials **612**, and it may be understood that the insulation layer **616** is provided between the insulation materials **612** and the first conductive materials **721** to **781**. The first conductive materials **721** to **791** may include a metal material.

[0170] The same structures as those on the first and second doping regions **811** and **812** may be provided in a region between the second and third doping regions **812** and **813**. In the region between the second and third doping regions **812** and **813**, provided are a plurality of insulation materials **612** extending along the first direction **D1**, a plurality of pillars **613** disposed sequentially along the first direction **D1** and penetrating the plurality of insulation materials **612** along the third direction **D3**, an insulation layer **616** provided on the exposed surfaces of the plurality of insulation materials **612** and the plurality of pillars **613**, and a plurality of conductive materials **713** to **793** extending along the first direction **D1**.

[0171] In a region between the third and fourth doping regions **813** and **814**, the same structures as those on the first and second doping regions **811** and **812** may be provided. In the region between the third and fourth doping regions **813** and **814**, provided are a plurality of insulation materials **612** extending along the first direction **D1**, a plurality of pillars **613** disposed sequentially along the first direction **D1** and penetrating the plurality of insulation materials **612** along the third direction **D3**, an insulation layer **616** provided on the exposed surfaces of the plurality of insulation materials **612** and the plurality of pillars **613**, and a plurality of first conductive materials **713** to **793** extending along the first direction **D1**.

[0172] Drains **820** are provided on the plurality of pillars **613**, respectively. On the drains **820**, the second conductive materials **831** to **833** extending along the first direction **D1** are provided. The second conductive materials **831** to **833** are disposed along the second direction **D2** and are spaced by a specific distance. The second conductive materials **831** to **833** are respectively connected to the drains **820** in a corresponding region. The drains **820** and the second conductive material **833** extending along the first direction **D1** may be connected through each contact plug. The second conductive materials **831** to **833** may include metal materials. The second conductive materials **831** to **833** may include conductive materials such as a polysilicon. However, the second conductive materials **831** to **833** are not limited thereto.

[0173] FIG. **16** is an equivalent circuit diagram illustrating the memory block **BLKi** of FIG. **15** according to exemplary embodiments.

[0174] The memory block **BLKi** of FIG. **16** may be formed on a substrate in a three-dimensional structure (or a vertical structure). For example, a plurality of memory cell strings included in the memory block **BLKi** may be formed in a direction perpendicular to the substrate.

[0175] Referring to FIG. **16**, the memory block **BLKi** may include memory cell strings **NS11** to **NS33** coupled between bit lines **BL1**, **BL2** and **BL3** and a common source line **CSL**. Each of the memory cell strings **NS11** to **NS33** may include a string selection transistor **SST**, a plurality of memory cells **MC1** to **MC12**, and a ground selection transistor **GST**.

[0176] The string selection transistor **SST** may be connected to corresponding string selection lines **SSL1** to **SSL3**. The plurality of memory cells **MC1** to **MC12** may be connected to corresponding word lines **WL1** to **WL12**, respectively. The ground selection transistor **GST** may be connected to corresponding ground selection lines **GSL1** to **GSL3**. The string selection transistor **SST** may be connected to corresponding bit lines **BL1**, **BL2** and **BL3**, and the ground selection transistor **GST** may be connected to the common source line **CSL**.

[0177] Word lines (e.g., **WL1**) having the same height may be commonly connected, and the ground selection lines **GSL1** to **GSL3** and the string selection lines **SSL1** to **SSL3** may be separated.

[0178] Referring back to FIG. **13**, the control circuit **450** may receive the command (signal) **CMD** and the address (signal) **ADDR** from the storage controller **300** and control an erase operation, a program operation and a read operation of the nonvolatile memory device **400a** based on the command signal **CMD** and the address signal **ADDR**.

[0179] For example, the control circuit **450** may generate control signals **CTLs**, which are used for controlling the voltage generator **470**, based on the command signal **CMD**, and may generate a row address **R_ADDR** and a column address **C_ADDR** based on the address signal **ADDR**. The control circuit **450** may provide the row address **R_ADDR** to the address decoder **460** and provide the column address **C_ADDR** to the data input/output circuit **420**. In addition, the control circuit **450** may generate a control signal **PCTL**, which is used for controlling the page buffer circuit **410**.

[0180] The address decoder **460** may be coupled to the memory cell array **430** through the string selection line **SSL**, the plurality of word lines **WLs**, and the ground selection line **GSL**.

[0181] The voltage generator **470** may generate word line voltages **VWLs** using the first operation voltage **VOP1**, which are used for the operation of the nonvolatile memory device **400a**, based on the control signals **CTLs**. The word line voltages **VWLs** may be applied to the plurality of word lines **WLs** through the address decoder **460**.

[0182] The page buffer circuit **410** may be coupled to the memory cell array **430** through the plurality of bit lines **BLs**. The page buffer circuit **410** may include a plurality of page buffers. In exemplary embodiments, one page buffer may be connected to one bit line, or one page buffer may be connected to two or more bit lines. The page buffer circuit **410** may temporarily store data to be programmed in a selected page or data read out from the selected page. The page buffer circuit **410** may be controlled in response to the control signal **PCTL** from the control circuit **450**.

[0183] The data input/output circuit 420 may be coupled to the page buffer circuit 410 through data lines DLs. During the program operation, the data input/output circuit 420 may receive program data DTA from the storage controller 300 and provide the program data DTA to the page buffer circuit 410 based on the column address C_ADDR received from the control circuit 450. During the read operation, the data input/output circuit 420 may provide read data DTA, which are stored in the page buffer circuit 410, to the storage controller 300 based on the column address C_ADDR received from the control circuit 450.

[0184] FIG. 17 is a flowchart illustrating a method of operating a portable storage device according to exemplary embodiments.

[0185] Referring to FIGS. 1 through 17, there is provided a method of operating a portable storage device 200 which includes a plurality of nonvolatile memory devices 400a~400k to store data, a storage controller 300 to control the plurality of nonvolatile memory devices 400a~400k, and a bridge chipset 220 connected to a first connector 110 of a host 100 through a cable assembly 30 connected to a second connector 210 of the bridge chipset 220.

[0186] According to the method in an exemplary embodiment, the bridge chipset 220 detects a resistance of the cable assembly 30 when power is applied to the portable storage device 200 (S210). A connection detector 240 in the bridge chipset 220 detects the resistance of the cable assembly 30 by detecting a voltage of the CC1 pin 212 of the second connector 210.

[0187] The connection detector 240 in the bridge chipset 220 determines the USB type of the first connector 110 based on the detected resistance (S220), and provides the power controller 360 in the storage controller 300 with USB type information UTI associated with the USB type of the first connector 110. The connection detector 240 in the bridge chipset 220 provides the storage controller 300 with USB version information UVI associated with an established USB connection after the USB connection is established between the portable storage device 200 and the host 100.

[0188] The bridge chipset 220 provides the USB type information UTI to the storage controller 300 through a first GPIO pin, and writes the USB version information UVI in the register 352 in the PCIe interface 351 in the interface unit 350 included in the storage controller 300.

[0189] The power controller 360 selects one of a plurality of initializing modes based on the USB type information UTI and USB version information UVI (S230), and may perform an initializing operation based on the selected initializing mode (S240). The power controller 360 may perform power throttling based on the selected initializing mode such that a power target level associated with the selected initializing mode is not exceeded.

[0190] The power throttling may be associated with selecting frequencies of clock signals having high performance to be provided to hardware elements such as the cores 311, 312 and 313, the system bus 305, and the nonvolatile controller 345 according to the USB type information and the USB version information such that a power target level associated with the selected initializing mode is not exceeded.

[0191] Therefore, the portable storage device 200 may reduce a time interval of an initializing operation and may optimize power by adaptively controlling power based on the USB type of the first connector 110 of the host 100,

connected through the cable assembly 30, and USB version information between the portable storage device 200 and the host 100.

[0192] In a comparative example, a storage device may adjust frequencies of clock signals after an initializing operation is completed. However, the portable storage device 200 according to exemplary embodiments may improve performance in a starting stage of the initializing operation.

[0193] FIG. 18 is a block diagram illustrating a storage system according to exemplary embodiments.

[0194] Referring to FIG. 18, a storage system 1000 includes a host 1100 and a portable storage device 1200.

[0195] The host 1100 and the portable storage device 1200 may be connected to each other through a cable assembly 1010.

[0196] The host 1100 includes an application 1110, a device driver 1120, a host controller 1130, a buffer random access memory (RAM) 1140, and a storage interface 1101. The host controller 1130 includes a command manager 1131, a host direct memory access (DMA) 1132, and a power manager 1133.

[0197] In operation, a system level command (e.g., a write command) is generated by the application 1110 and device driver 1120 of the host 1100, and is then provided to the command manager 1131 of the host controller 1130.

[0198] The command manager 1131 may be used to generate a corresponding portable storage device command (e.g., a corresponding command or set of commands consistent with a protocol being implemented by the storage system 1000) that is provided to the portable storage device 1200 using the device driver 1120.

[0199] The command generated by the command manager 1131 may also be provided to the host DMA 1132, which sends the command to the portable storage device 1200 via the storage interface 1101. The storage interface 1101 may include a first connector such as the first connector 110 and may be connected to the cable assembly 1010 through the first connector 110.

[0200] The portable storage device 1200 includes non-volatile memory devices 1210, a device controller 1230, a buffer RAM 1240, and a host interface 1201. The device controller 1230 may include a central processing unit (CPU) 1231, a device DMA 1232, a flash DMA 1233, a command manager 1234, a buffer manager 1235, a flash translation layer (FTL) 1236, a flash manager 1237, and a power controller 1238.

[0201] A command transferred from the host 1100 to the portable storage device 1200 may be provided to the device DMA 1232 via the host interface 1201. The host interface 1201 may include a second connector such as the second connector 210 and a bridge chipset 1205. The bridge chipset 1205 may employ the bridge chipset 220 in FIG. 5.

[0202] The device DMA 1232 may then communicate the received command to the command manager 1234. The command manager 1234 may be used to allocate memory space in the buffer RAM 1240 to receive corresponding write data via the buffer manager 1235. Once the portable storage device 1200 is ready to receive the write data, the command manager 1234 may communicate a transmission "ready" signal to the host 1100.

[0203] Upon receiving the transmission ready signal, the host 1100 will communicate the write data to the portable

storage device **1200**. The write data may be sent to the portable storage device **1200** using the host DMA **1132** and storage interface **1101**.

[0204] The portable storage device **1200** may then store the received write data in the buffer RAM **1240** using the device DMA **1232** and buffer manager **1235**. The write data stored in the buffer RAM **1240** may then be provided to the flash manager **1237** via the flash DMA **1233**. The flash manager **1237** may be used to program the write data according to addresses for the nonvolatile memory devices **1210** derived from an address mapping table by the flash translation layer **1236**.

[0205] Once the transfer and programming of the write data is complete, the portable storage device **1200** may send a response to the host **1100** informing the host **1100** that the write command has been successfully executed. Based on the received response signal, the host **1100** indicates to the device driver **1120** and application **1110** that the command is complete, and will thereafter terminate execution of the operation corresponding to the command.

[0206] As described above, the host **1100** and portable storage device **1200** may exchange data and corresponding control signal(s) (e.g., the ready and response signals) via data lines of the data segment (e.g., data lines DIN and DOUT). In addition, the host **1100** may provide a command CMD and an address ADDR to the portable storage device **1200**.

[0207] The power controller **1238** may employ the power controller **360** in FIG. 8.

[0208] Therefore, in the portable storage device **1200** in the storage system **1000**, the bridge chipset **1205** may detect a resistance of the cable assembly **1010** in response to power being applied to the portable storage device **1200** from the host **1100** through the cable assembly **1010**, and may determine a USB type of the first connector **110** based on the detected resistance.

[0209] In addition, the portable storage device **1200** may obtain USB version information when a USB connection is established between the host **1100** and the portable storage device **1200**. The power controller **1238** may select one of a plurality of initializing modes based on the USB type and the USB version information, and may perform an initializing operation based on the selected initializing mode. Therefore, the portable storage device **1200** may reduce a time interval of an initializing operation and may optimize power by adaptively controlling power based on the USB type and the USB version information.

[0210] A portable storage device or a storage system according to exemplary embodiments may be packaged using various package types or package configurations.

[0211] Exemplary embodiments of the present disclosure may be applied to various portable storage devices and various electronic devices connected to the portable storage devices.

[0212] As is traditional in the field of the present disclosure, exemplary embodiments are described, and illustrated in the drawings, in terms of functional blocks, units and/or modules. Those skilled in the art will appreciate that these blocks, units and/or modules are physically implemented by electronic (or optical) circuits such as logic circuits, discrete components, microprocessors, hard-wired circuits, memory elements, wiring connections, etc., which may be formed using semiconductor-based fabrication techniques or other manufacturing technologies. In the case of the blocks, units

and/or modules being implemented by microprocessors or similar, they may be programmed using software (e.g., microcode) to perform various functions discussed herein and may optionally be driven by firmware and/or software. Alternatively, each block, unit and/or module may be implemented by dedicated hardware, or as a combination of dedicated hardware to perform some functions and a processor (e.g., one or more programmed microprocessors and associated circuitry) to perform other functions. Also, each block, unit and/or module of the exemplary embodiments may be physically separated into two or more interacting and discrete blocks, units and/or modules without departing from the scope of the invention. Further, the blocks, units and/or modules of the exemplary embodiments may be physically combined into more complex blocks, units and/or modules without departing from the scope of the present disclosure.

[0213] As will be appreciated by one skilled in the art, aspects of the present disclosure may be embodied as a system, method or computer program product. Accordingly, aspects of the present disclosure may take the form of an entirely hardware embodiment, an entirely software embodiment (including firmware, resident software, micro-code, etc.) or an embodiment combining software and hardware aspects that may all generally be referred to herein as a “circuit,” “module,” “unit” or “system.” Furthermore, aspects of the present disclosure may take the form of a computer program product embodied in one or more computer readable medium(s) having computer readable program code embodied thereon. If implemented in software, the functions may be stored on or transmitted over as one or more instructions or code on a tangible, non-transitory computer-readable medium.

[0214] Herein, the term “circuit” may refer to an analog circuit or a digital circuit. In the case of a digital circuit, the digital circuit may be hard-wired to perform the corresponding tasks of the circuit, such as a digital processor that executes instructions to perform the corresponding tasks of the circuit. Examples of such a processor include an application-specific integrated circuit (ASIC) and a field-programmable gate array (FPGA).

[0215] In an exemplary embodiment of the present disclosure, a three dimensional (3D) memory array is provided. The 3D memory array is monolithically formed in one or more physical levels of arrays of memory cells having an active area disposed above a silicon substrate and circuitry associated with the operation of those memory cells, whether such associated circuitry is above or within such substrate. The term “monolithic” means that layers of each level of the array are directly deposited on the layers of each underlying level of the array. In an exemplary embodiment of the present disclosure, the 3D memory array includes vertical NAND strings that are vertically oriented such that at least one memory cell is located over another memory cell. The at least one memory cell may include a charge trap layer. The following patent documents, which are hereby incorporated by reference, describe suitable configurations for three-dimensional memory arrays, in which the three-dimensional memory array is configured as a plurality of levels, with word lines and/or bit lines shared between levels: U.S. Pat. Nos. 7,679,133; 8,553,466; 8,654,587; 8,559,235; and US Pat. Pub. No. 2011/0233648.

[0216] While the present disclosure has been particularly shown and described with reference to the exemplary

embodiments thereof, it will be understood by those of ordinary skill in the art that various changes in form and detail may be made therein without departing from the spirit and scope of the present disclosure as defined by the following claims.

1. A portable storage device, comprising:

a plurality of nonvolatile memory devices configured to store data;

a storage controller configured to control the plurality of nonvolatile memory devices; and

a bridge chipset connected to a first connector of a host through a cable assembly,

wherein the bridge chipset is configured to:

detect a resistance of the cable assembly;

provide the storage controller with universal serial bus (USB) type information of the first connector based on the detected resistance; and

after a USB connection is established with the host, provide the storage controller with USB version information associated with the established USB connection,

wherein the storage controller, independently from the host, is configured to:

select one of a plurality of initializing modes based on the USB type information and the USB version information;

select clock signals having frequencies in a range within a maximum power level associated with the selected initializing mode; and

perform an initializing operation based on the selected clock signals within an internal reference time interval.

2. The portable storage device of claim 1, wherein:

the bridge chipset comprises a connection detector configured to detect the resistance of the cable assembly via a first pin of a plurality of pins in a second connector of the portable storage device,

wherein the second connector is connected to the cable assembly, and the first pin corresponds to a first configuration channel (CC) pin from among the plurality of pins in the second connector;

the first CC pin is used for at least one of detecting a connection of the portable storage device, determining an insertion direction of a plug, and managing a configuration of the portable storage device and the host through the cable assembly; and

the bridge chipset is configured to provide the USB type information to the storage controller through a first general purpose input/output (GPIO) pin.

3. The portable storage device of claim 2,

wherein the connection detector is configured to:

maintain a voltage level of the first GPIO pin hard-wired to a second GPIO pin of the storage controller at a first level during a first time interval after a power is applied;

change the voltage level of the first GPIO pin to a second level different from the first level during a second time interval successive to the first time interval; and

change the voltage level of the first GPIO pin to the first level at a time point in a third time interval successive to the second time interval,

wherein the storage controller is configured to:

determine the USB type information based on a voltage level of the second GPIO pin after the third time interval elapses;

write the USB type information in a register in the storage controller within a fourth time interval after the third time interval; and

determine the USB version information in response to a write event in the register.

4. The portable storage device of claim 3, wherein the connection detector is configured to notify the storage controller that a USB type of the first connector is USB type-C by maintaining the voltage level of the first GPIO pin at the first level during the third time interval based on a comparison of a voltage of the first CC pin with a threshold value.

5. The portable storage device of claim 3, wherein the connection detector is configured to notify the storage controller that a USB type of the first connector is USB type-A by changing the voltage level of the first GPIO pin from the first level to the second level during the third time interval based on a comparison of a voltage of the first CC pin with a threshold value.

6. The portable storage device of claim 1, wherein the internal reference time interval is smaller than or equal to about 10 seconds.

7. The portable storage device of claim 1, wherein the storage controller comprises:

an interface unit configured to perform interfacing between the host and the nonvolatile memory devices; and

a power controller configured to select one of the plurality of initializing modes based on the USB type information and the USB version information to perform the initializing operation,

wherein a connection detector disposed in the bridge chipset is configured to:

provide the USB type information to the storage controller through a first general purpose input/output (GPIO) pin of the connection detector, wherein the first GPIO pin is hard-wired to a second GPIO pin of the storage controller; and

write the USB version information in a register in a peripheral component interconnect express (PCIe) interface in the interface unit.

8. The portable storage device of claim 7, wherein:

the bridge chipset and the storage controller are configured to communicate with each other via side-band communication through the first GPIO pin and the second GPIO pin, respectively; and

the connection detector and the register in the PCIe interface are configured to communicate with each other via in-band communication and through a non-volatile memory express (NVMe) interface.

9. The portable storage device of claim 7, wherein the power controller is configured to:

select the clock signals having the frequencies based on the USB type information and the USB version information in the register; and

perform power throttling to adjust a level of power consumed in the selected initializing mode.

10. The portable storage device of claim 7, wherein:

the power controller comprises a look-up table configured to store information on power targets associated with the plurality of initializing modes, respectively; and

the power controller is configured to perform the initializing operation by selecting a first initializing mode corresponding to a first power target from among the plurality of initializing modes before receiving the USB type information and the USB version information, wherein the first power target has a minimum power level from among the plurality of power targets.

11. The portable storage device of claim **10**, wherein the power controller is configured to perform the initializing operation by selecting a second initializing mode corresponding to a second power target from among the plurality of initializing modes, in response to the USB type information indicating that a USB type of the first connector corresponds to USB type-C,

wherein the second power target has a maximum power level among from the plurality of power targets.

12. (canceled)

13. The portable storage device of claim **10**, wherein the power controller is configured to perform the initializing operation by maintaining the first initializing mode in response to the USB type information indicating that the first connector does not correspond to USB type-C and the USB version information does not correspond to USB 3.0 or higher.

14. The portable storage device of claim **7**, wherein the storage controller comprises a plurality of cores configured to perform control operations associated with the nonvolatile memory devices,

wherein the power controller comprises:

a clock generator configured to generate base clock signals and divided clock signals by dividing the base clock signals, and to provide the plurality of cores with the base clock signals and the divided clock signals as the selected clock signals;

a selection circuit configured to select the selected clock signals provided to the plurality of cores in response to selection signals; and

a control logic configured to generate the selection signals based on the USB type information and the USB version information.

15. The portable storage device of claim **14**, wherein the control logic is further configured to generate the selection signals such that clock signals having frequencies associated with an initializing mode corresponding to a maximum power target from among the plurality of initializing modes are selected, in response to the USB type information indicating that the first connector corresponds to USB type-C.

16. The portable storage device of claim **14**, wherein the control logic is further configured to generate the selection signals such that clock signals having frequencies associated with an initializing mode corresponding to an intermediate power target from among the plurality of initializing modes are selected, in response to the USB type information indicating that the first connector does not correspond to USB type-C and the USB version information corresponding to USB 3.0 or higher,

wherein the intermediate power target is greater than a minimum power target and is smaller than a maximum power target.

17. The portable storage device of claim **14**, wherein the control logic is further configured to generate the selection signals such that clock signals having frequencies associated with an initializing mode corresponding to a minimum

power target from among the plurality of initializing modes are selected, in response to the USB type information indicating that the first connector does not correspond to USB type-C and the USB version information not corresponding to USB 3.0 or higher.

18. The portable storage device of claim **1**, wherein each of the plurality of nonvolatile memory devices comprises a memory cell array, and the memory cell array comprises a plurality of memory cells coupled to a plurality of word lines stacked in a vertical direction that is perpendicular to a substrate.

19. A method of operating a portable storage device, comprising:

detecting, in a bridge chipset, a resistance of a cable assembly,

wherein the portable storage device comprises a plurality of nonvolatile memory devices configured to store data, a storage controller configured to control the plurality of nonvolatile memory devices, and the bridge chipset connected to a first connector of a host through the cable assembly connected to a second connector of the bridge chipset;

determining universal serial bus (USB) type information of the first connector based on the detected resistance; selecting, in the storage controller, one of a plurality of initializing modes based on the USB type information and USB version information associated with a USB connection established with the host, independently from the host; and

performing power throttling based on the selected initializing mode.

20. The method of claim **19**, wherein the bridge chipset is configured to:

provide the USB type information to the storage controller through a first general purpose input/output (GPIO) pin; and

write the USB version information in a register in a peripheral component interconnect express (PCIe) interface in an interface unit included in the storage controller.

21. (canceled)

22. (canceled)

23. A portable storage device, comprising:

a plurality of nonvolatile memory devices configured to store data;

a storage controller configured to control the plurality of nonvolatile memory devices; and

a bridge chipset connected to a first connector of a host through a cable assembly,

wherein the bridge chipset is configured to:

detect a resistance of the cable assembly;

provide the storage controller with connection information of the first connector based on the detected resistance; and

after a connection is established with the host, provide the storage controller with version information associated with the established connection,

wherein the storage controller, independently from the host, is configured to:

select one of a plurality of initializing modes based on the connection information and the version information;

select clock signals having frequencies in a range within a maximum power level associated with the selected initializing mode; and perform an initializing operation based on the selected clock signals within an internal reference time interval.

* * * * *