



US 20190198000A1

(19) **United States**

(12) **Patent Application Publication**  
**OSHIRO**

(10) **Pub. No.: US 2019/0198000 A1**

(43) **Pub. Date: Jun. 27, 2019**

(54) **AUDIO DEVICE AND ELECTRONIC INSTRUMENT**

*G10C 3/12* (2006.01)

*G10K 15/08* (2006.01)

(71) Applicant: **CASIO COMPUTER CO., LTD.**,  
Tokyo (JP)

(52) **U.S. Cl.**  
CPC ..... *G10H 1/32* (2013.01); *G10C 3/02*  
(2013.01); *G10H 2210/325* (2013.01); *G10K*  
*15/08* (2013.01); *G10C 3/12* (2013.01)

(72) Inventor: **Atsushi OSHIRO**, Tokyo (JP)

(73) Assignee: **CASIO COMPUTER CO., LTD.**,  
Tokyo (JP)

(57) **ABSTRACT**

An audio device and an electronic instrument are provided by which a device case can be downsized. An elastic member is interposed between an attachment hole provided in a panel-side sealed frame section of a speaker panel and a projection section of a speaker grill and, in this state, the speaker grill is fixed to the speaker panel by the projection section being subjected to torsion deformation. By the elastic member being deformed inside the attachment hole and coming in close contact with the surface of the projection section and the inner surface of the attachment hole, the attachment hole that is a through hole is filled. As a result of this structure, an attachment hole that is used when a speaker grill is attached to a speaker panel can be arranged at a position where it penetrates to an acoustic space.

(21) Appl. No.: **16/231,526**

(22) Filed: **Dec. 23, 2018**

(30) **Foreign Application Priority Data**

Dec. 27, 2017 (JP) ..... 2017-251039

**Publication Classification**

(51) **Int. Cl.**  
*G10H 1/32* (2006.01)  
*G10C 3/02* (2006.01)

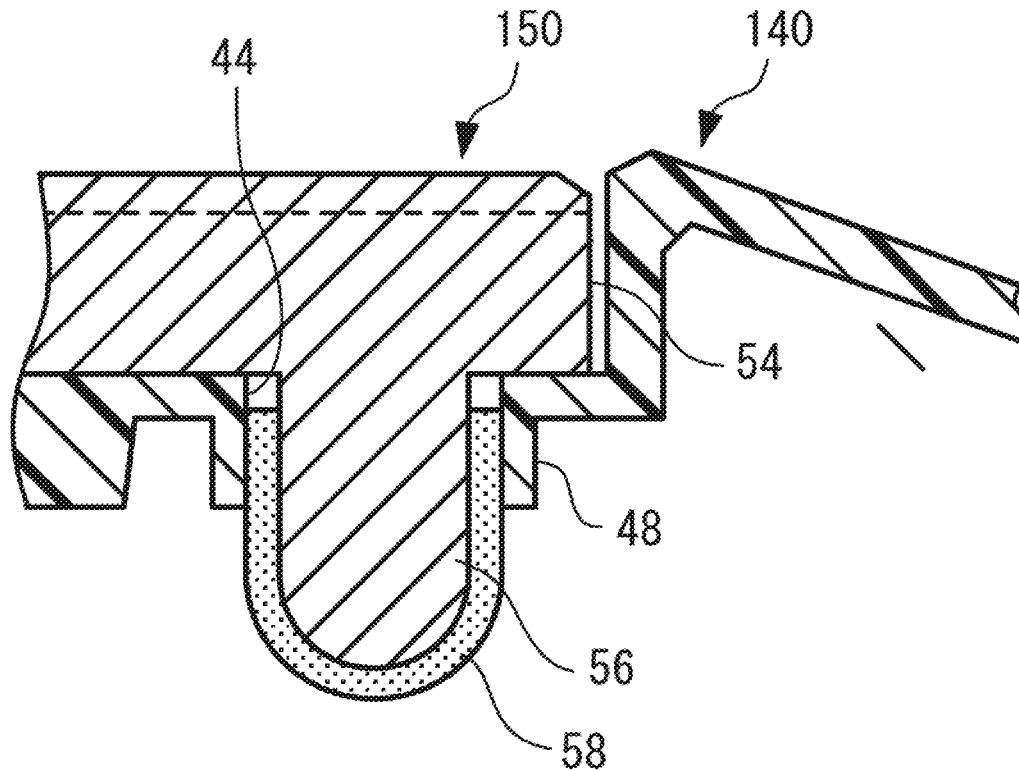

FIG. 1

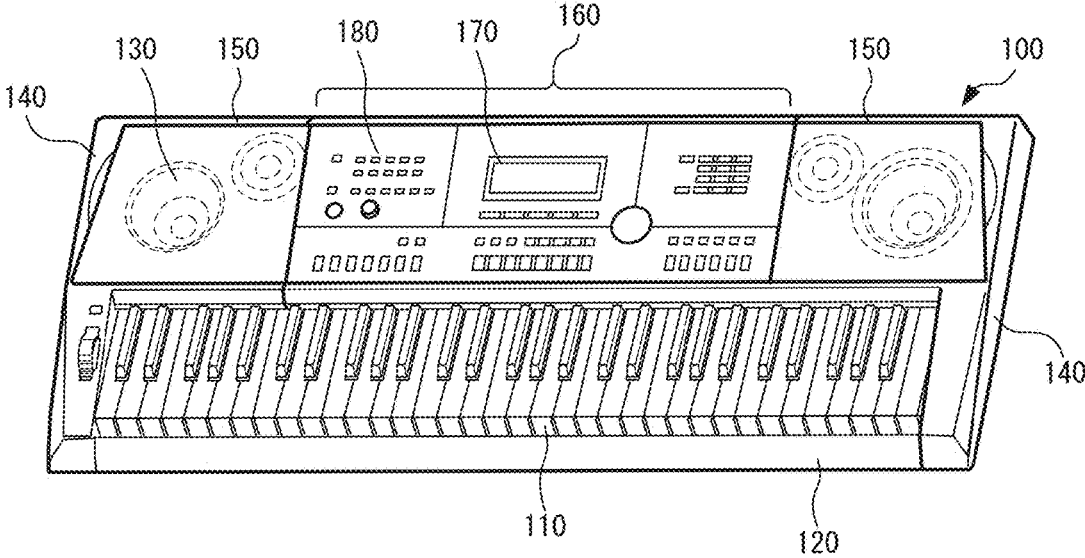

FIG. 2

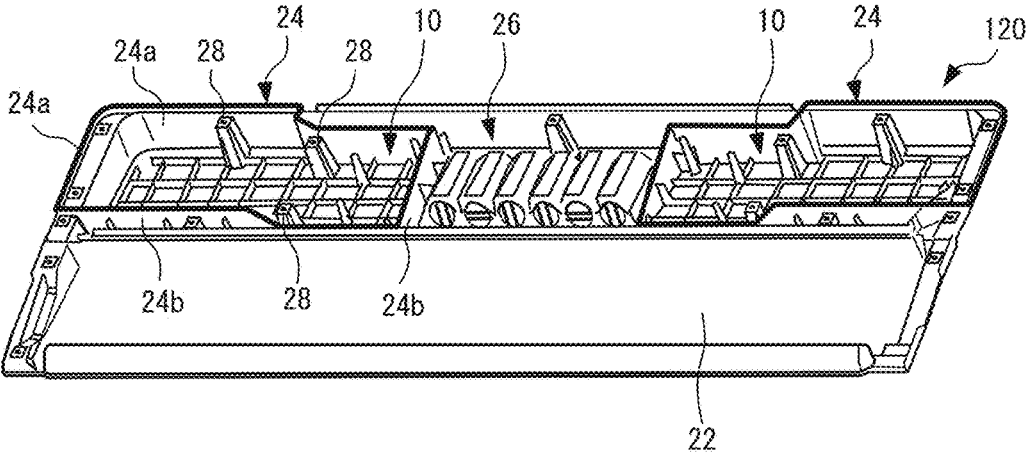

FIG. 3A

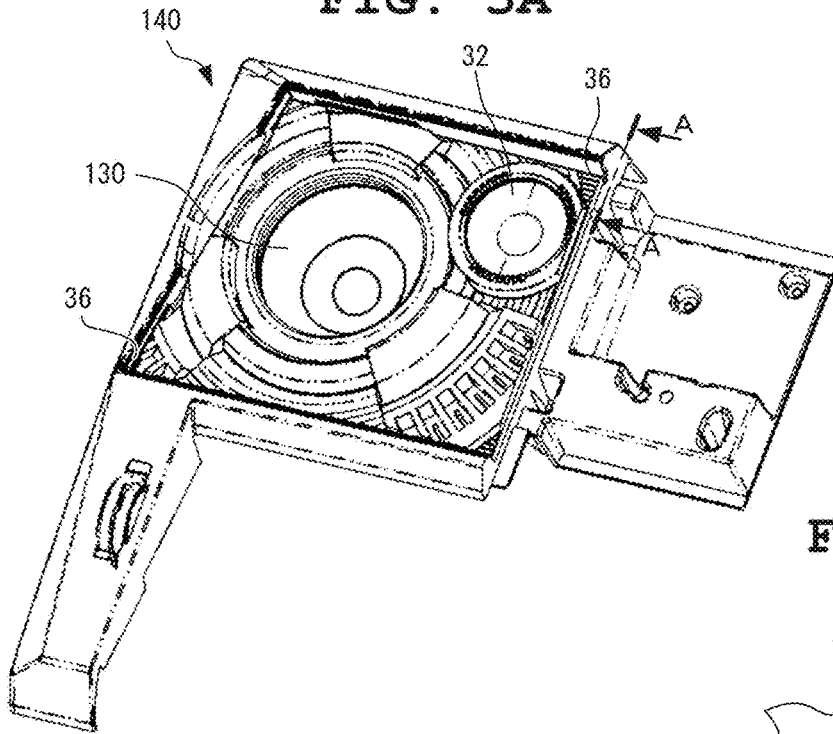
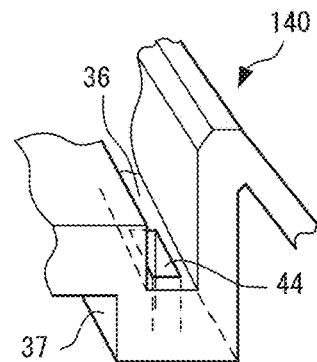

FIG. 3B



SECTIONAL VIEW  
TAKEN ALONG  
LINE A-A

FIG. 3C

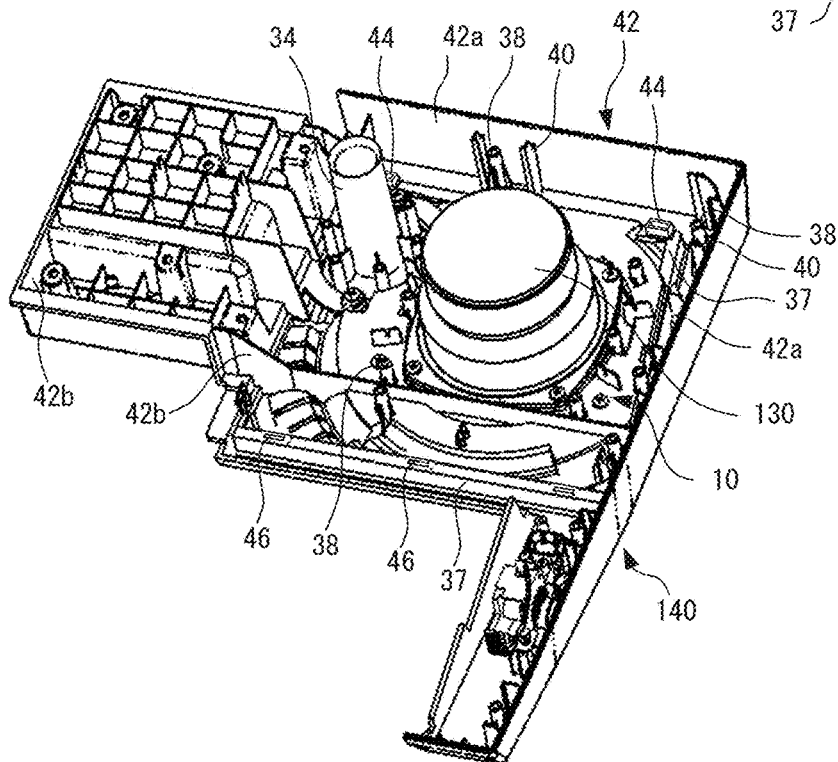

FIG. 4A

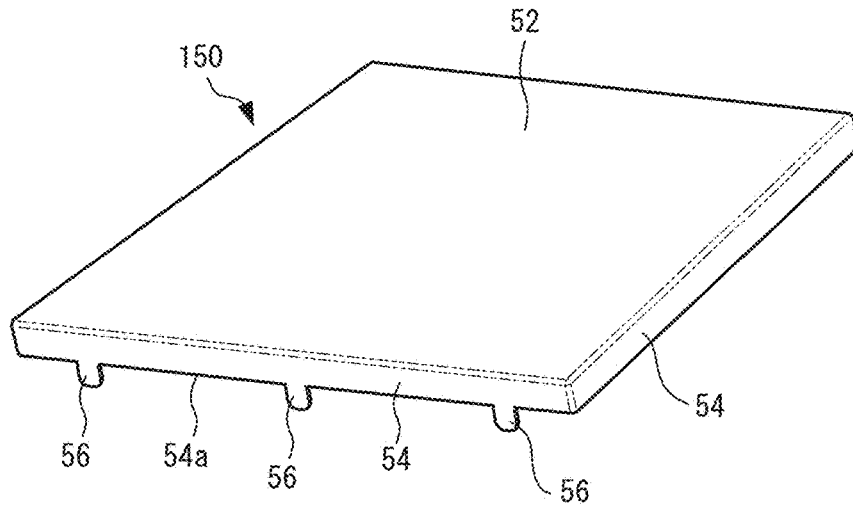

FIG. 4B

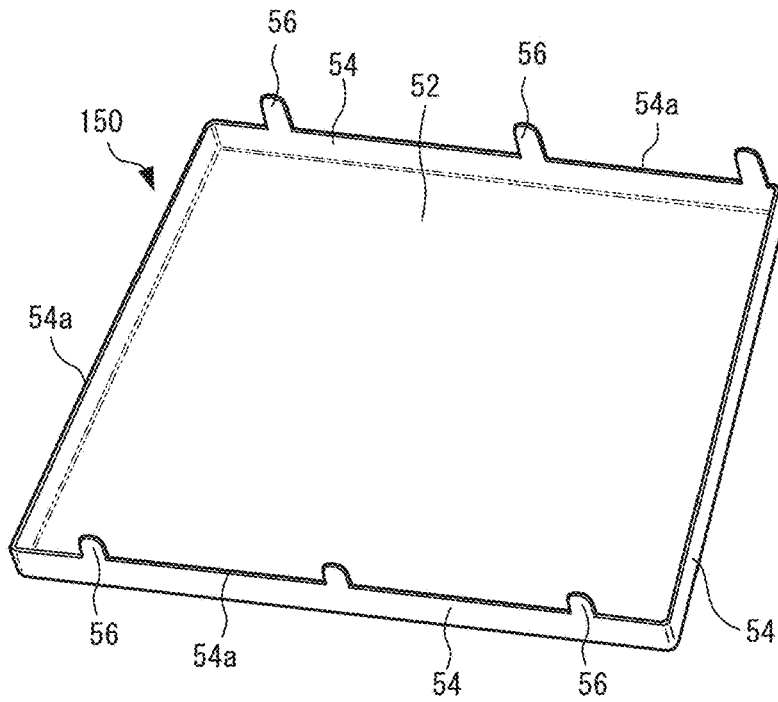

FIG. 5A

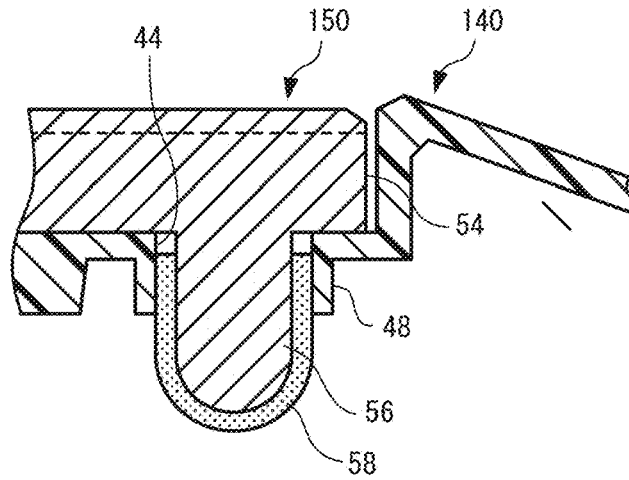

FIG. 5B

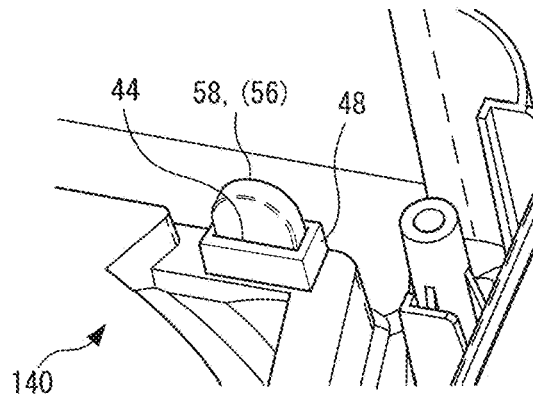

FIG. 5C

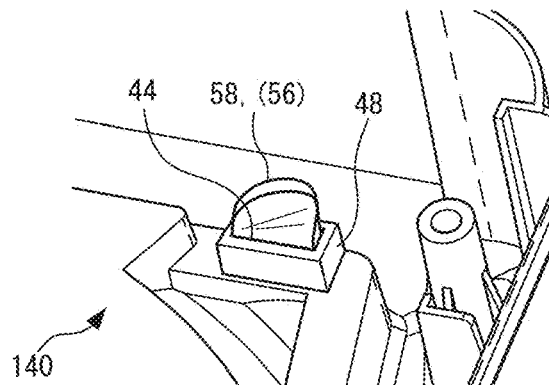

FIG. 6A

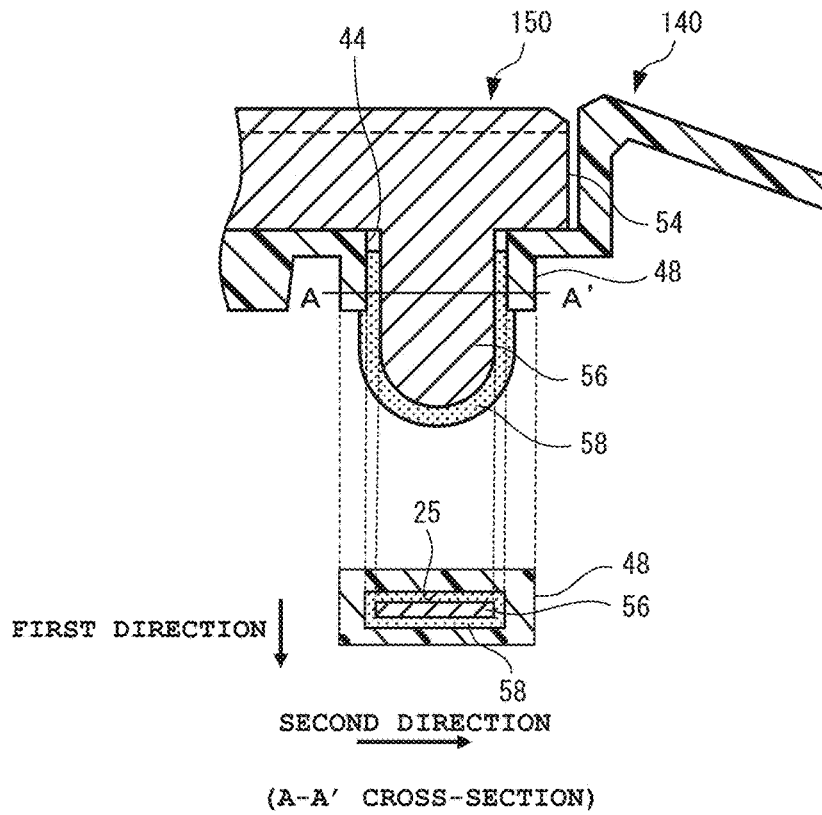

FIG. 6B

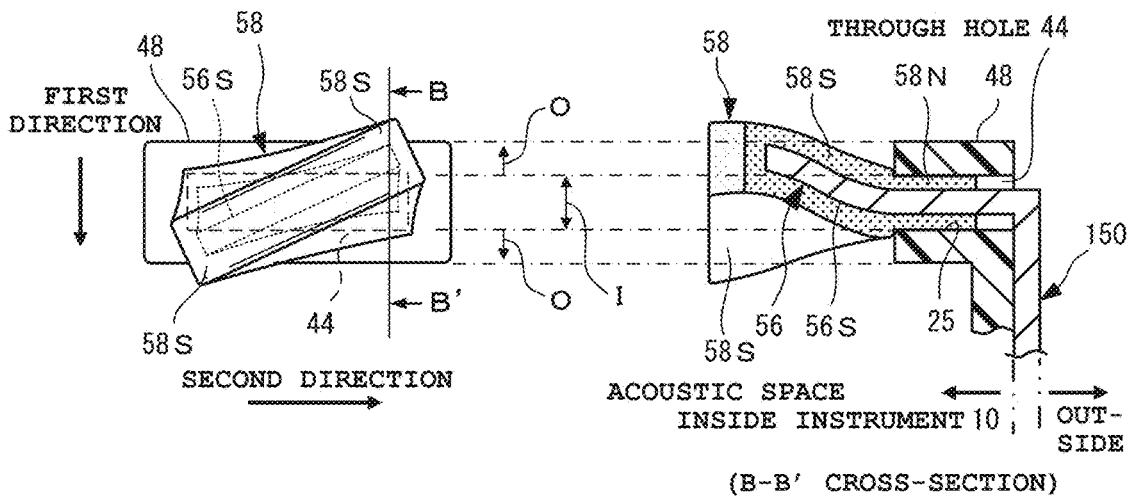

FIG. 7A

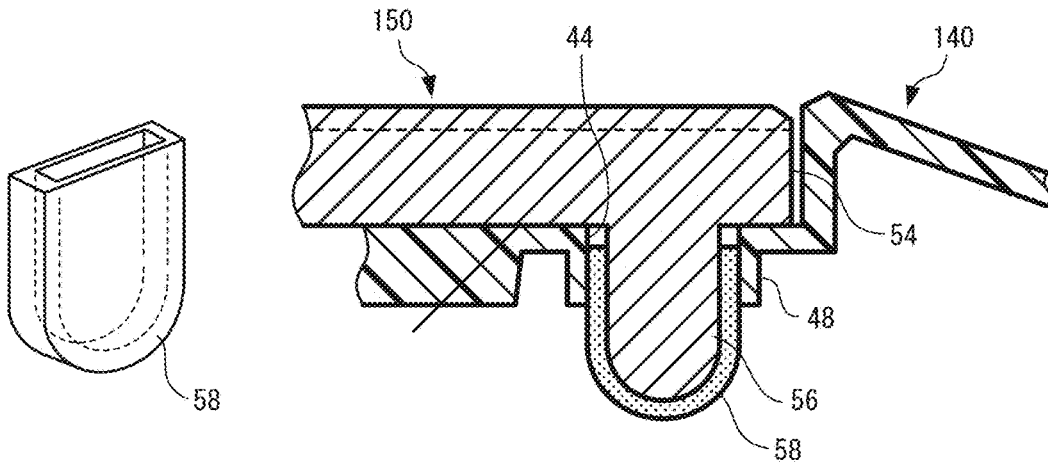

FIG. 7B

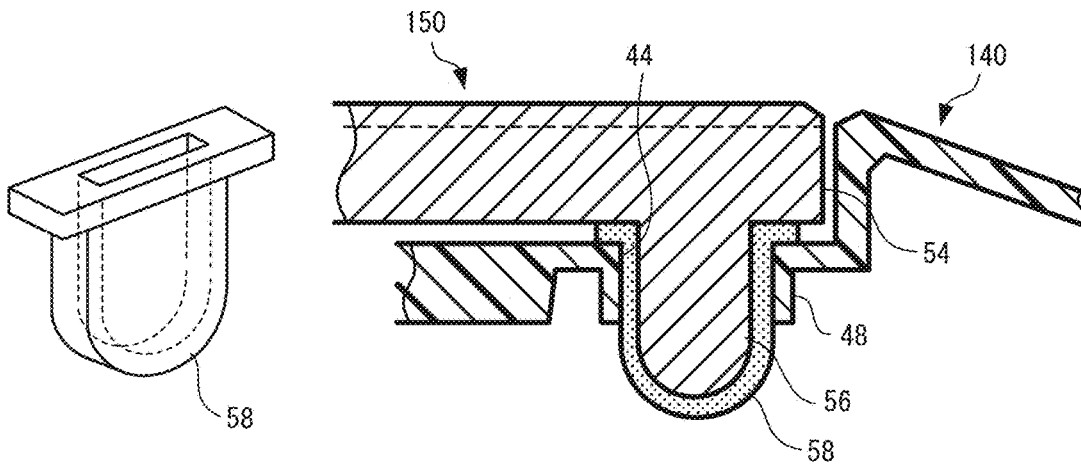

FIG. 7C

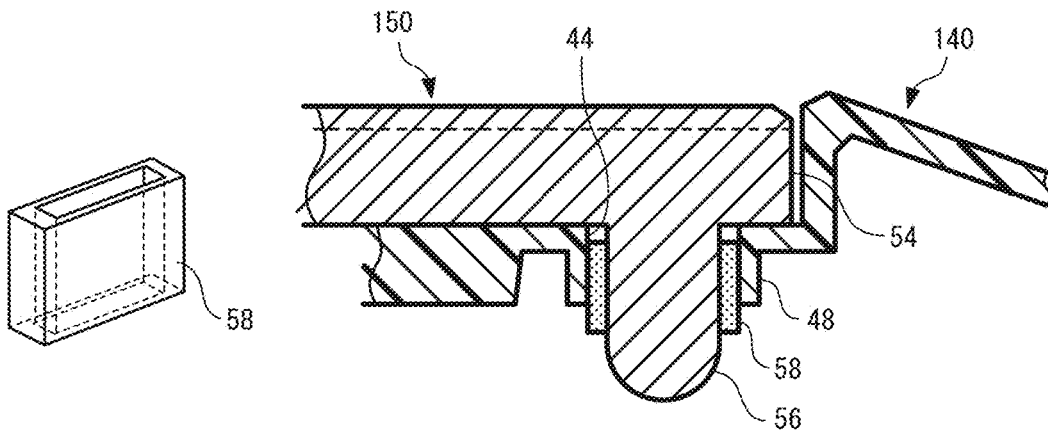



FIG. 8A

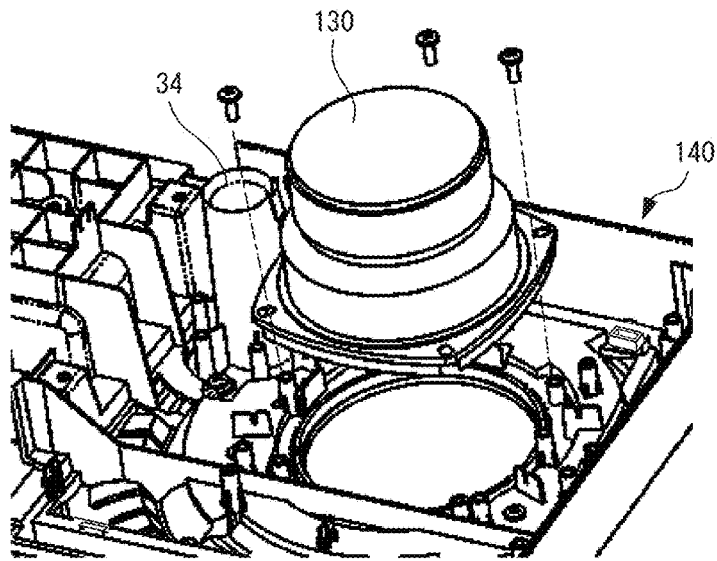

FIG. 8B

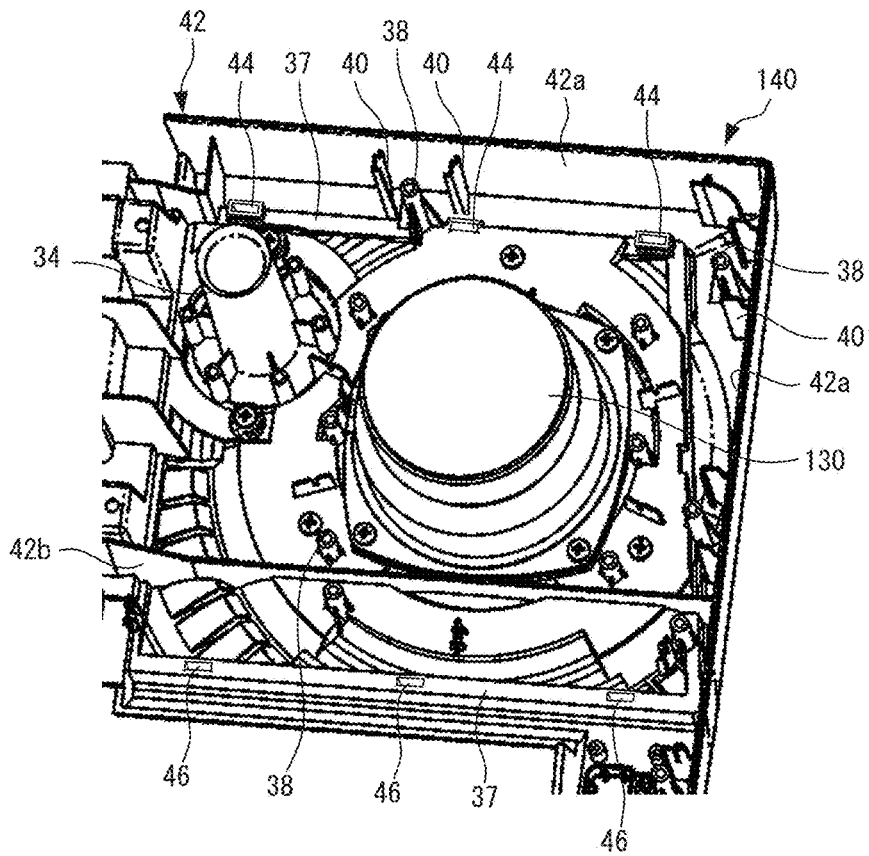

FIG. 9

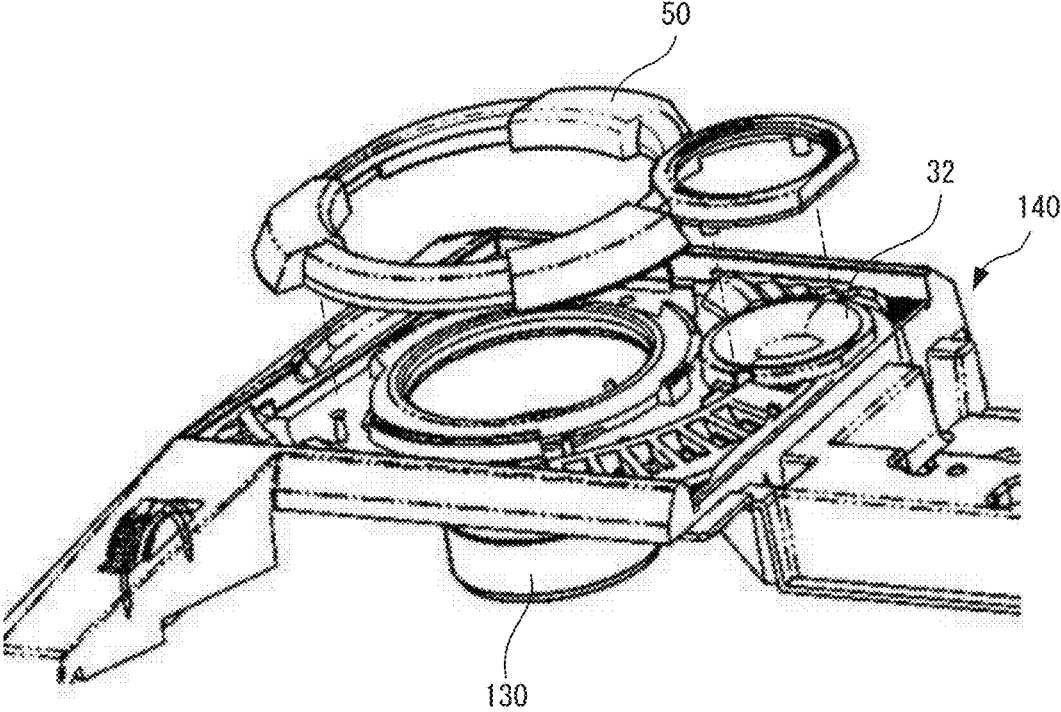

FIG. 10A

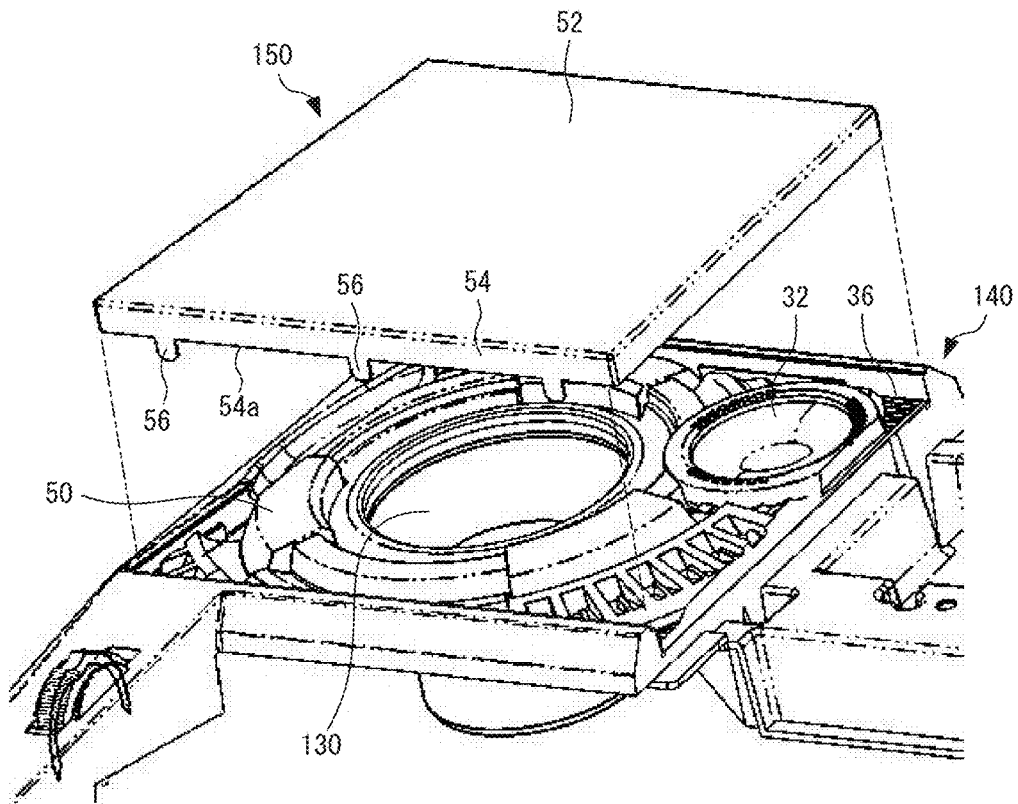

FIG. 10B

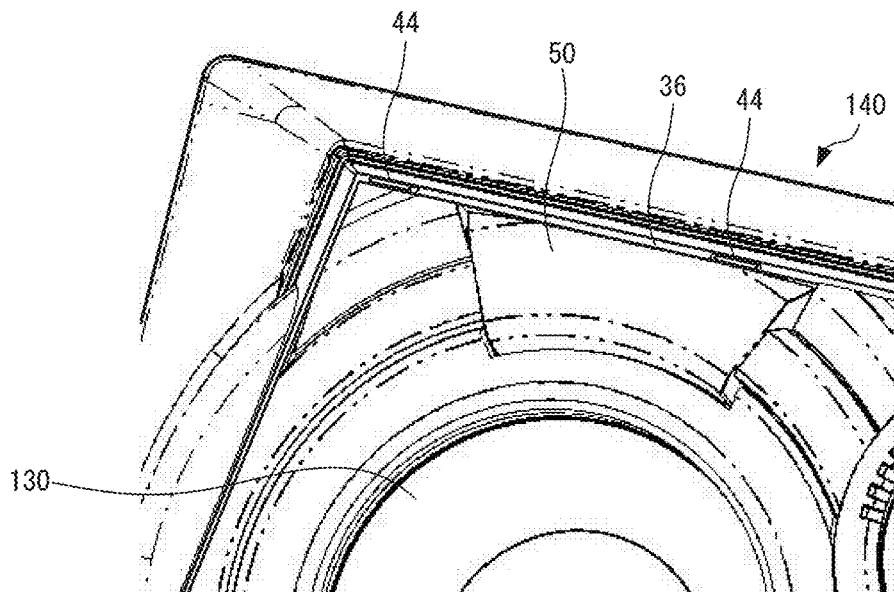

FIG. 11A

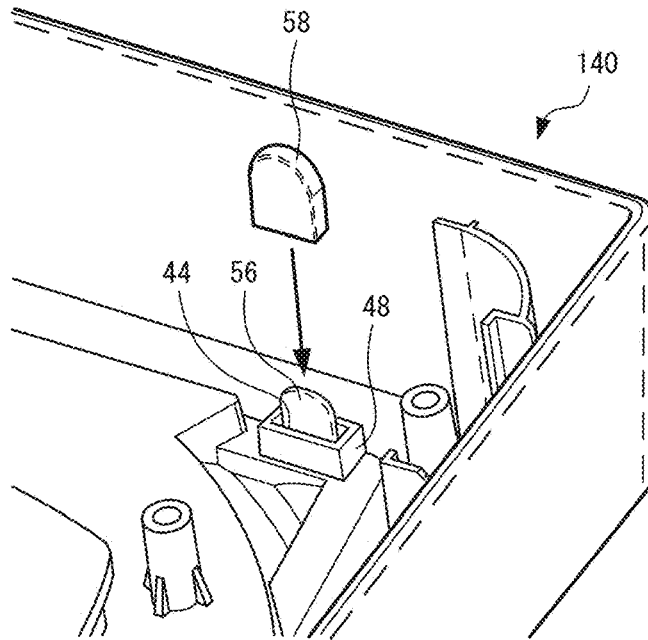

FIG. 11B

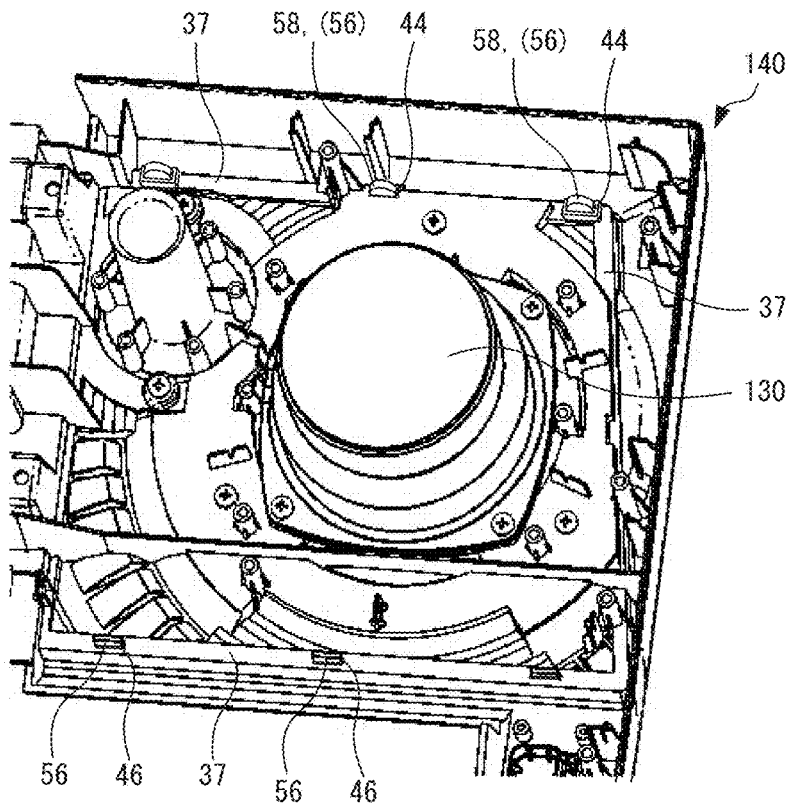

FIG. 12A

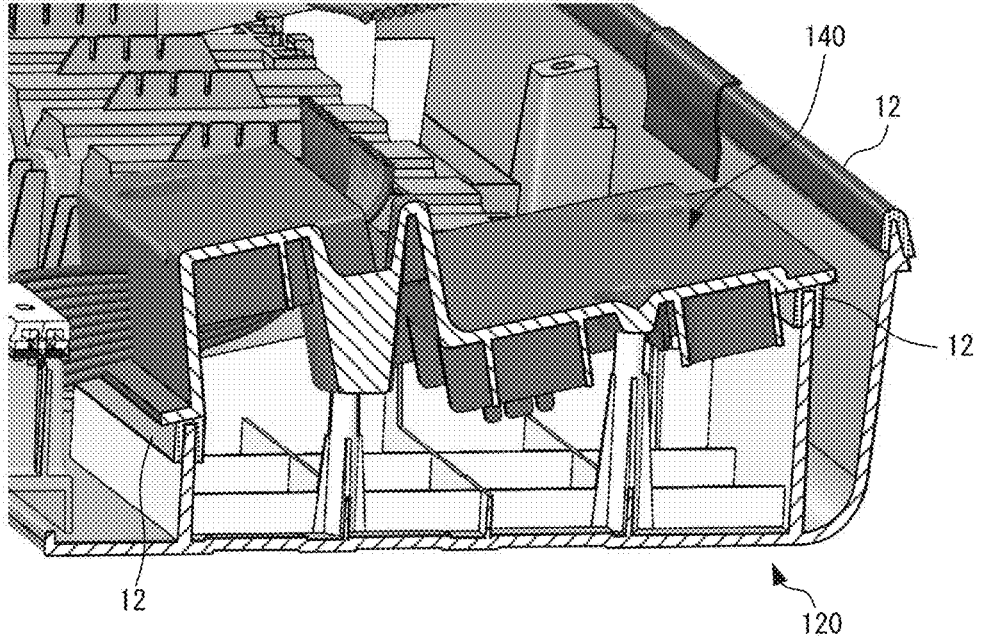

FIG. 12B

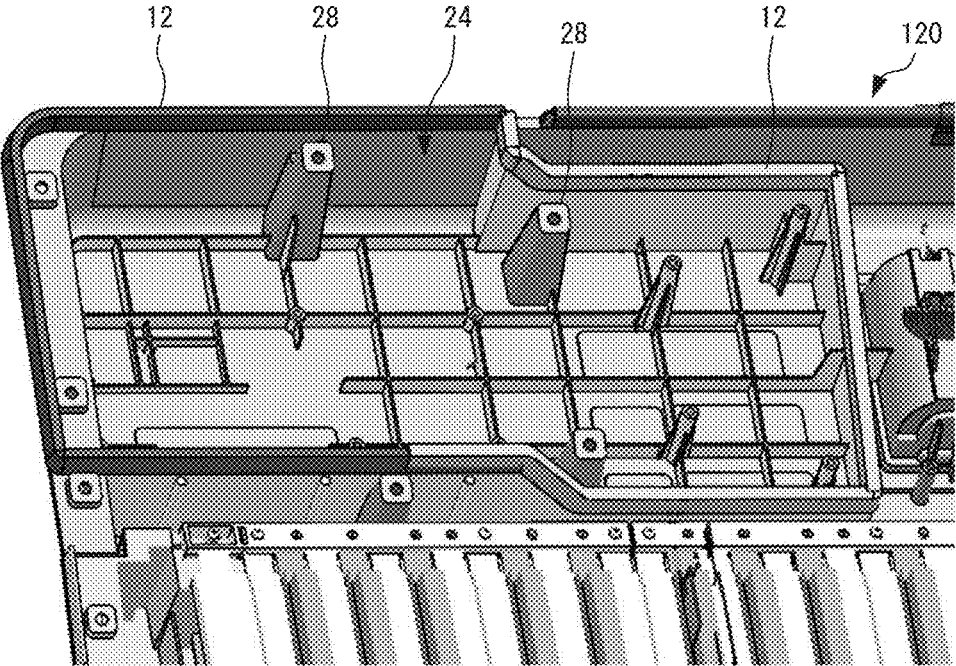
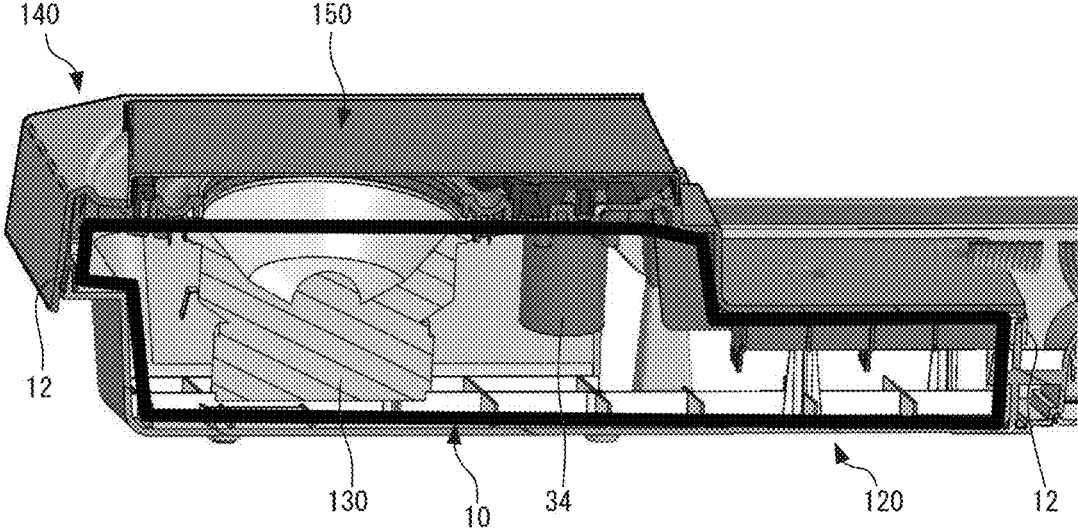
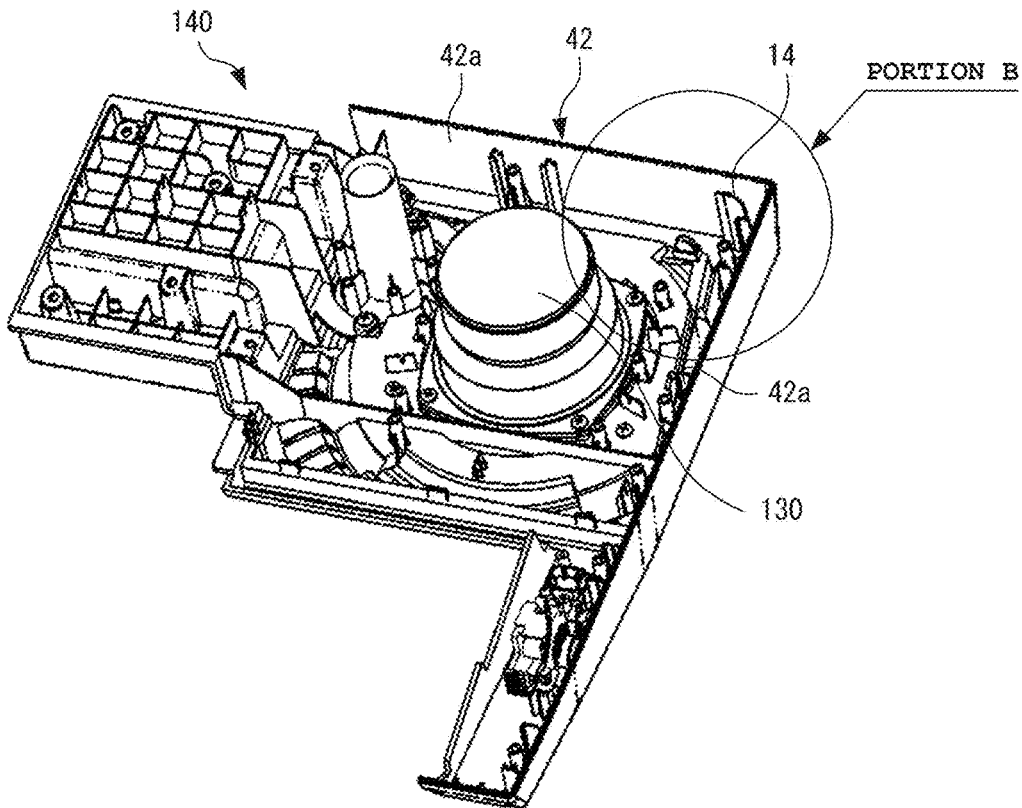

FIG. 13



**FIG. 14A**



**FIG. 14B**

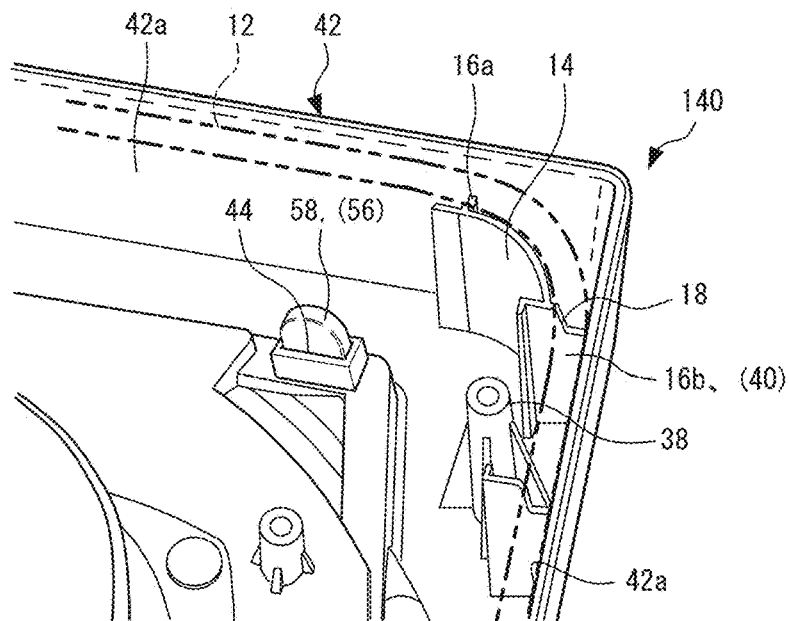

DETAILS OF PORTION B

FIG. 15A

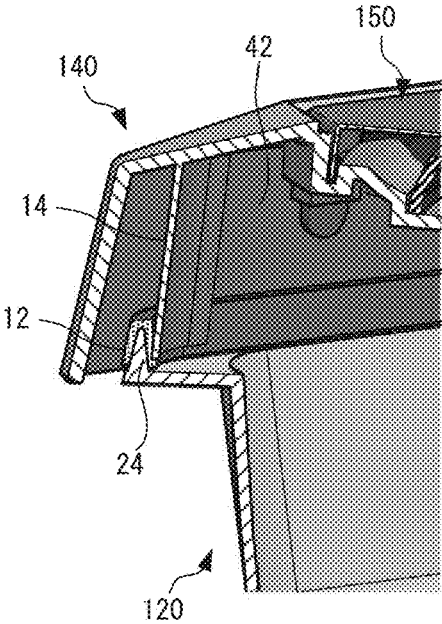

FIG. 15B

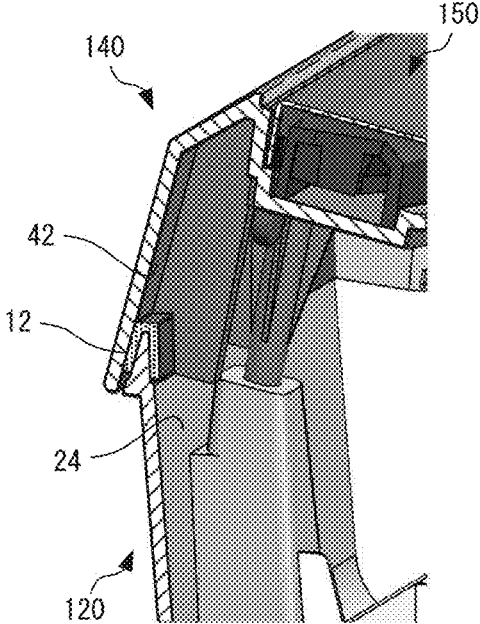
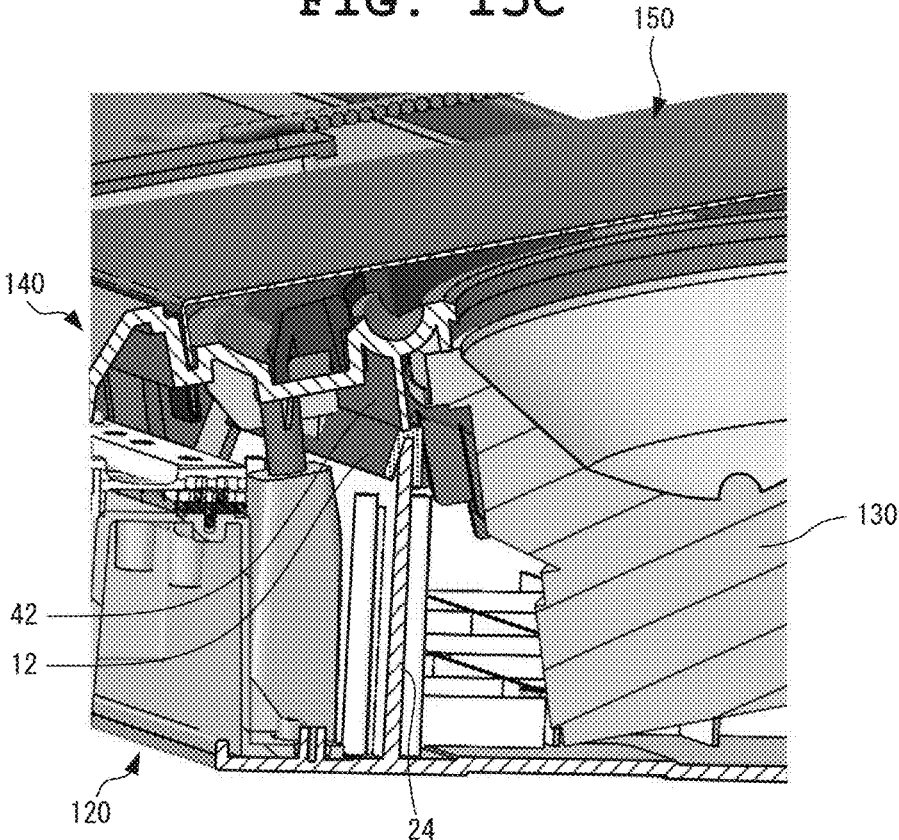

FIG. 15C





## AUDIO DEVICE AND ELECTRONIC INSTRUMENT

### CROSS-REFERENCE TO RELATED APPLICATION

[0001] This application is based upon and claims the benefit of priority from the prior Japanese Patent Application No. 2017-251,039, filed Dec. 27, 2017, the entire contents of which are incorporated herein by reference.

### BACKGROUND OF THE INVENTION

#### 1. Field of the Invention

[0002] The present invention relates to an audio device and an electronic instrument.

#### 2. Description of the Related Art

[0003] Conventionally, as an audio device such as an electronic instrument and a speaker having a bass reflex structure or a sealing structure, an audio device is known in which an upper case and a lower case are included, a frame shaped upper partition plate that surrounds a side part of an attached speaker is provided in the upper case, a frame shaped lower partition plate that also surrounds the side part of the speaker is provided in the lower case such that it is opposed to the upper partition plate, and the upper partition plate and the lower partition plate constitutes a speaker accommodation section that is a sealed acoustic space, as described in Japanese Patent Application Laid-Open (Kokai) Publication No. 05-241574.

[0004] In the audio device of Japanese Patent Application Laid-Open (Kokai) Publication No. 05-241574 which has the structure including the sealed acoustic space (speaker accommodation section), if an attachment hole for a speaker grill (sound hole net body) that protects the sound emission surface (vibration plate) of the speaker is provided penetrating to the acoustic space when the speaker grill is mounted on the outer side of the upper case, the leakage of sound and air occurs from the attachment hole, whereby the sealed state of the acoustic space cannot be maintained. As a result, low pitched sounds cannot be emitted during musical sound emission and the primary characteristics of the bass reflex structure are deteriorated.

[0005] As described above, the conventional technique has a problem in that the attachment hole for the speaker grill cannot be formed at a position where it penetrates to the acoustic space, and is required to be provided outside the acoustic space, which impedes the downsizing of electronic instrument cases or audio device cases.

[0006] The present invention has an advantageous effect in that an audio device and an electronic instrument whose device or instrument case can be downsized are provided.

### SUMMARY OF THE INVENTION

[0007] In accordance with one aspect of the present invention, there is provided an audio device comprising: a main body case having an inner wall defining a through hole connected to an acoustic space formed around at least one speaker provided inside the main body case; a cover member having a projection section inserted into the through hole such that a distal end of the projection section projects to the acoustic space side from the through hole; and an elastic member which covers the distal end of the projection section

and whose at least one portion is arranged between the inner wall and the projection section in the through hole, wherein at least one portion of the elastic member covering the distal end and at least one portion of the distal end are arranged in a space located outside a space surrounded by an extended line of the inner wall, whereby the cover member is fixed to the main body case.

[0008] The above and further objects and novel features of the present invention will more fully appear from the following detailed description when the same is read in conjunction with the accompanying drawings. It is to be expressly understood, however, that the drawings are for the purpose of illustration only and are not intended as a definition of the limits of the invention.

### BRIEF DESCRIPTION OF THE DRAWINGS

[0009] The present invention can be more clearly understood by the detailed description below when considered together with the following drawings.

[0010] FIG. 1 is an outer appearance view of an electronic keyboard instrument serving as an embodiment of an audio device and an electronic instrument according to the present invention;

[0011] FIG. 2 is a schematic diagram showing an example of a base body case applied to the electronic keyboard instrument according to the embodiment;

[0012] FIG. 3A to FIG. 3C are schematic diagrams showing an example of a speaker panel applied to the electronic keyboard instrument according to the embodiment;

[0013] FIG. 4A and FIG. 4B are schematic diagrams showing an example of a speaker grill applied to the electronic keyboard instrument according to the embodiment;

[0014] FIG. 5A to FIG. 5C are diagrams showing details of a projection section of the speaker grill applied to the electronic keyboard instrument according to the embodiment;

[0015] FIG. 6A and FIG. 6B are diagrams concretely describing the fixation structure of the speaker grill applied to the electronic keyboard instrument according to the embodiment;

[0016] FIG. 7A to FIG. 7C are schematic diagrams showing examples of the shape of an elastic member applied to the electronic keyboard instrument according to the embodiment;

[0017] FIG. 8A and FIG. 8B are first schematic diagrams showing an example of an assembly method for the electronic keyboard instrument according to the embodiment;

[0018] FIG. 9 is a second schematic diagram showing the example of the assembly method for the electronic keyboard instrument according to the embodiment;

[0019] FIG. 10A and FIG. 10B are third schematic diagrams showing the example of the assembly method for the electronic keyboard instrument according to the embodiment;

[0020] FIG. 11A and FIG. 11B are fourth schematic diagrams showing the example of the assembly method for the electronic keyboard instrument according to the embodiment;

[0021] FIG. 12A and FIG. 12B are schematic diagrams showing an example of a packing applied to the base body case of the electronic keyboard instrument according to the embodiment;

[0022] FIG. 13 is a schematic diagram showing an acoustic space demarcated in the electronic keyboard instrument according to the embodiment;

[0023] FIG. 14A and FIG. 14B are schematic diagrams showing an example of a case structure of a speaker panel of the electronic keyboard instrument according to one embodiment; and

[0024] FIG. 15A to FIG. 15C are schematic diagrams showing an example of a sealing structure in an assembled state of the electronic keyboard instrument according to one embodiment.

#### DETAILED DESCRIPTION OF THE PREFERRED EMBODIMENTS

[0025] An embodiment of an audio device and an electronic instrument according to the present invention will hereinafter be described in detail with reference to the drawings. In the present embodiment, an electronic keyboard instrument (electronic keyboard) is described as an example of the audio device and the electronic instrument of the present invention.

[0026] <Electronic Keyboard Instrument>

[0027] FIG. 1 is an outer appearance view of an electronic keyboard instrument serving as an embodiment of an audio device and an electronic instrument according to the present invention, and FIG. 2 is a schematic diagram showing an example of a base body case applied to the electronic keyboard instrument according to the embodiment. Also, FIG. 3A to FIG. 3C are schematic diagrams showing an example of a speaker panel applied to the electronic keyboard instrument according to the embodiment, and FIG. 4A and FIG. 4B are schematic diagrams showing an example of a speaker grill applied to the electronic keyboard instrument according to the embodiment. Moreover, FIG. 5A to FIG. 5C are diagrams showing details of a projection section of the speaker grill applied to the electronic keyboard instrument according to the embodiment, and FIG. 6A and FIG. 6B are diagrams concretely describing the fixation structure of the speaker grill applied to the electronic keyboard instrument according to the embodiment. FIG. 7A to FIG. 7C are schematic diagrams showing examples of the shape of an elastic member applied to the electronic keyboard instrument according to the embodiment.

[0028] As shown in FIG. 1, an electronic keyboard instrument 100 according to the present embodiment mainly includes a musical instrument case constituted by a base body case 120 mounted with a keyboard unit 110, speaker panels 140 mounted with speakers 130 and covered by speaker grills 150, and a center panel 160 provided with a display section 170 and an operation switch 180.

[0029] The base body case 120 has a box shape that is long in the right and left direction of the drawing, and has a structure where its upper side in the drawing is open, as shown in FIG. 2. In an area along a side surface portion (hereinafter referred to as "front side portion") of the base body case 120 on the lower side of the drawing, a keyboard mounting section 22 is provided in which a well-known keyboard unit 110 is mounted, as shown in FIG. 1. The keyboard unit 110 has white keys and black keys which are arrayed in the right and left direction of the drawing and used to specify sound pitches.

[0030] Also, in left and right end areas on a side surface portion (hereinafter referred to as "back side portion") of the base body case 120 on the upper side of the drawing,

base-body-side sealed frame sections 24 that demarcate acoustic spaces 10 are provided, as shown in FIG. 2. In an area between the left and right base-body-side sealed frame sections 24 on the back side portion of the base body case 120, a battery accommodation section 26 is provided.

[0031] Each base-body-side sealed frame section 24 includes an outer-peripheral-side frame section 24a extending along the outer edge of the base body case 120 on its back side and its left or right side, and an inner-side frame section 24b extending along a boundary between the corresponding acoustic space 10 and the keyboard mounting section 22 and a boundary between the corresponding acoustic space 10 and the battery accommodation section 26 in the base body case 120, as shown in FIG. 2. By these frame sections 24a and 24b, the entire periphery of each acoustic space 10 is surrounded in the base body case 120.

[0032] On the entire peripheries of the upper ends (the open end side of the base body case 120) of the outer-peripheral-side frame section 24a and the inner-side frame section 24b of each base-body-side sealed frame section 24, a packing not shown (described later) is provided, and left and right speaker panels 140 are mounted on and come in close with the base-body-side sealed frame sections 24 via each packing. In the vicinities of the left and right base-body-side sealed frame sections 24 in the base body case 120, panel attachment bosses 28 each having a screw inserting hole for assembling and fixing the speaker panels 140 to the base body case 120 are provided.

[0033] The speaker panels 140, each of which has a speaker 130, a tweeter 32, and a bass reflex port 34 provided therein, are arranged on left and right areas of the back side portion of the base body case 120, as shown in FIG. 3A and FIG. 3C. Also, each speaker panel 140 has a shape corresponding to side portions of the base-body-side sealed frame section 24 of the base body case 120 and the keyboard unit 110, and is attached to the base body case 120. Moreover, inside each speaker panel 140, a panel-side sealed frame section 42 is provided which has a shape corresponding to the related base-body-side sealed frame section 24 of the base body case 120 and demarcates the corresponding acoustic space 10, as shown in FIG. 3C.

[0034] Each panel-side sealed frame section 42 includes an outer-peripheral-side frame section 42a extending along an outer edge portion on the side surface (back side portion) of the speaker panel 140 on the upper side in the drawing and an outer edge portion on the right side (or left side) of the speaker panel 140, and an inner-side frame section 42b extending along a boundary portion of the keyboard mounting section 22 and a boundary portion of the battery accommodation section 26 in the speaker panel 140, as shown in FIG. 3C. By these frame sections 42a and 42b, the entire periphery of the corresponding acoustic space 10 is surrounded in the corresponding speaker panel 140.

[0035] Furthermore, the outer-peripheral-side frame section 42a and the inner-side frame section 42b of each panel-side sealed frame section 42 have shapes corresponding to the shape of the upper end of the corresponding base-body-side sealed frame section 24 of the base body case 120, and the speaker panels 140 are mounted on and come in close contact with the base-body-side sealed frame sections 24 of the base body case 120 via packings (not shown). In the vicinities of the panel-side sealed frame sections 42 of the left and right speaker panels 140, panel attachment bosses 38 having screw holes are provided at

positions corresponding to the positions of the plurality of panel attachment bosses 28 provided in the base body case 120. Also, in the vicinity of each panel attachment boss 38, a reinforcement rib 40 for ensuring the housing strength of the corresponding speaker panel 140 is integrally provided with, for example, the outer-peripheral-side frame section 42a and the inner-side frame section 42b of the corresponding panel-side sealed frame section 42.

[0036] As such, the base-body-side sealed frame sections 24 of the base body case 120 and the panel-side sealed frame sections 42 of the speaker panels 140 correspond vertically, and come in close contact via the packings, whereby the sealed acoustic spaces 10 are formed in the musical instrument case including the base body case 120 and the speaker panels 140 (refer to the thick line of FIG. 13). Here, in a state where the speaker panels 140 have been mounted on the base body case 120, the plurality of panel attachment bosses 28 provided in the base body case 120 and the plurality of panel attachment bosses 38 provided in the speaker panels 140 correspond in a one-to-one relation, and the speaker panels 140 are fixed to the base body case 120 by each set of panel attachment bosses 28, 38 being fixed by a screw.

[0037] In the present embodiment, each speaker panel 140 is designed such that its outer shape is slightly larger than the base body case 120 due to the design of the product, the layout of the members to be provided inside, restrictions in the manufacturing technique and the like. That is, the speaker panels 140 outwardly project in a peaked roof shape with respect to the outer edge of the base body case 120 which is the end of the planar breadth of the base body case 120. Note that a sealing structure for an acoustic space which can be applied to the musical instrument case having the above-described structure will be described later.

[0038] The speaker grills 150 are provided on the upper surfaces of the speaker panels 140 so as to protect the sound emission surfaces of the speakers 130 and the tweeters 32 exposed from the speaker panels 140, as shown in FIG. 1. Each speaker grill 150 includes a grill main body 52 having a main surface on which a mesh-like sound hole (not shown) or the like is provided, outer peripheral sections 54 which constitute a frame shape and each of which is formed by the outer periphery of the grill main body 52 being bent in a perpendicular direction with respect to the main surface, and a plurality of projection sections 56 provided projecting in the perpendicular direction with respect to the main surface from sides (edge side sections) 54a that are the edges of some of the outer peripheral sections 54, as shown in FIG. 4A and FIG. 4B. The speaker grills 150 are attached and fixed to the speaker panels 140 by the projection sections 56 being inserted into attachment holes 44 and 46 provided in the speaker panels 140, and the distal ends of the projection sections 56 being deformed and held in the speaker panels 140.

[0039] Here, the attachment structure of one speaker grill 150 to the corresponding speaker panel 140 is concretely described. On the upper surface side of the speaker panel 140, linear grooves 36 are provided to which the edge side sections 54a of at least the outer peripheral sections 54 having the plurality of projection sections 56 among the outer peripheral sections 54 of the speaker grill 150 are fitted, as shown in FIG. 3A, FIG. 3B, FIG. 10B and the like. In the linear grooves 36, a plurality of attachment holes 44 and 46 are provided at positions corresponding to the projection sections 56 projecting from the outer peripheral

sections 54 of the speaker grill 150. That is, the speaker grill 150 is a cover member and includes, at its outer periphery, the outer peripheral sections 54 and the projection sections 56 projecting from some of the outer peripheral section 54. On the other hand, the speaker panel 140 is a second housing that constitutes a case main body with the base body case 120 that is a first housing, and includes, in its inner peripheral portions, the linear grooves 36 corresponding to the shapes of the outer peripheral sections 54 of the speaker grill 150. The plurality of attachment holes 44 and 46 provided in the bottom surfaces of the linear grooves 36 penetrate to the acoustic space 10 from a space outside the main body case constituted by the base body case 120 and the speaker panel 140.

[0040] In the present embodiment, by the linear grooves 36 being provided on the upper surface side of the speaker panels 140, the thickness of each speaker panel 140 is partially thin. Accordingly, in the present embodiment, in areas where the linear grooves 36 are provided in each speaker panel 140, convex areas 37 projecting in accordance with the depths of the linear grooves 36 are provided to partially increase the thickness, whereby the strength of each speaker panel 140 is ensured, as shown in FIGS. 3B, 3C, 8B and the like. In cases where the convex areas 37 cannot be provided due to, for example, the layout of members provided inside each speaker panel 140, at least a hole rib 48 (thick thickness portion) described later should preferably be provided around each attachment hole (through hole) 44 or 46.

[0041] The attachment holes 44 and 46 provided in the linear grooves 36 are through holes penetrating through the corresponding speaker panel 140 from the upper surface (outer surface) side to the inner side, and at least some of them are provided inside each panel-side sealed frame section 42 demarcating the corresponding acoustic space 10. In an area around each attachment hole 44 or 46, the hole rib 48 is provided which has a thick portion projecting in the inserting direction (downward direction in FIG. 5A or upward direction in FIG. 5B) of the corresponding projection section 56, as shown in FIG. 3C, FIG. 5A and FIG. 5B. Alternatively, the area around each attachment hole 44 or 46 is designed to be a thick portion, as shown in FIG. 3B or FIG. 8B. These attachment holes 44 and 46 are arranged near the reinforcement ribs 40 provided near the panel attachment bosses 38 that are used when the speaker panels 140 are mounted on and fixed to the base body case 120, as shown in FIG. 8B.

[0042] In each speaker panel 140 applied in the present embodiment, in addition to the above-described linear grooves 36, a grill accommodation section is provided on the upper surface side, in which the corresponding speaker grill 150 is entirely accommodated such that the main surface of the speaker grill 150 (grill main body 52) coincides with (flush with) the outer surface of the speaker panel 140 when the speaker grill 150 is attached, as shown in FIG. 5A, FIG. 10A, FIG. 13 and the like. In this embodiment, the linear grooves 36 are provided along the four corners and the four sides of the bottom surface of each grill accommodation section, and the plurality of attachment holes 44 and 46 corresponding to the projection sections 56 of the speaker grills 150 are provided in the linear grooves 36.

[0043] As shown in FIG. 5A, the edge side sections 54a of the outer peripheral sections 54 of each speaker grill 150 are fitted into the linear grooves 36 of the corresponding speaker

panel 140 and the projection sections 56 of the speaker grill 150 are inserted into the attachment holes 44 and 46 of the speaker panel 140 by the speaker grill 150 being fitted into the corresponding grill accommodation section with the outer peripheral sections 54 of the speaker grill 150 being arranged along the inner surfaces of the linear grooves 36 of the speaker panel 140. In this embodiment, the attachment position (accommodation position) of each speaker grill 150 with respect to the corresponding speaker panel 140 is automatically determined by the linear grooves 36 of the speaker panel 140, and the projection sections 56 are reliably inserted to the attachment holes 44 and 46, so that the attachment work is made more efficient.

[0044] In the relation between the inner size of each attachment hole 44 or 46 provided in the speaker panels 140 and the outer size of the corresponding projection section 56, the outer size of the projection section 56 is smaller than the inner size of the attachment hole 44 or 46 so that the projection section 56 is easily inserted into the attachment hole 44 or 46 when the speaker grills 150 are attached to the speaker panels 140. Accordingly, in the state where the speaker grills 150 have been attached to the speaker panels 140, a gap is formed between each attachment hole 44 or 46 and the corresponding projection section 56.

[0045] In the present embodiment, an elastic member 58 is attached to each projection section 56 inserted into the corresponding one of the attachment holes 44 provided in the panel-side sealed frame sections 42 demarcating the acoustic spaces 10, and thereby interposed at least between the attachment hole 44 and the projection section 56, as shown in FIG. 5A and FIG. 5B. Then, the distal end of the projection section 56 exposed inside the corresponding speaker panel 140 from the attachment hole 44 having the hole rib 48 is twisted and deformed (hereinafter referred to as "torsional deformation"), so that the speaker grill 150 is fixed to the speaker panel 140 in a held state, as shown in FIG. 5C.

[0046] Here, by the projection section 56 being subjected to torsion deformation with the elastic member 58 being interposed between the attachment hole 44 and the projection section 56, the elastic member 58 is deformed inside the attachment hole 44 and comes in close contact with the surface of the projection section 56 and the inner surface of the attachment hole 44, whereby the attachment hole 44 that is a through hole is filled. That is, by the torsion deformation of the projection section 56 attached with the elastic member 58, the fixing of the speaker grill 150 and the sealing of the attachment hole 44 can be simultaneously achieved.

[0047] FIG. 6A and FIG. 6B are diagrams concretely describing the fixation structure of one speaker grill (cover member) 150 in the corresponding panel-side sealed frame section 42. In FIG. 6A, a state is shown in which one of the projection sections 56 projecting from the outer peripheral sections 54 of the speaker grill 150 have been inserted to one of the attachment holes (through hole) 44 in the hole ribs (thick portion) 48 included in the main body case, and the above-described elastic member 58 has been compressed and inserted into the attachment hole 44. As a result of this insertion, the attachment hole 44 has been filled by the elastic member 58. Note that, in the cross-section taken along A-A', the attachment hole 44 has a frame shape in which the length in the first direction is shorter than the length in the second direction. Similarly, in the cross-section taken along A-A', the projection section 56 has a frame

shape where the length in the first direction is shorter than the length in the second direction, as with the shape of the attachment hole 44. In this state, the elastic member 58 falls off to the inside of the acoustic space 10 with time, so that the speaker grill 150 may be separated from the main body case. The hole rib 48 projects toward the inside.

[0048] FIG. 6B is a diagram showing a state after the distal end 568 of the projection section 56 of the speaker grill 150 and the elastic member 58 are twisted from the state of FIG. 6A. As a result, the risk that the speaker grill 150 is separated the main body case (speaker panel 140) is reduced. Here, the distal end 568 of the projection section 56 is a portion projecting from the hole rib 48 toward the acoustic space 10 in the inner area. The distal end 568 of the projection section 56 and the elastic member 58 are rotated from the state shown in FIG. 6A in the acoustic space 10. As a result, the elastic member 58 is more closely attached to the inner wall 25 of the attachment hole 44 than the state of FIG. 6A. In the state shown in FIG. 6B, the distal end 568 of the projection section 56 and a portion of the elastic member 58 are in space a located outside an extended line of the inner wall 25 of the attachment hole 44. As a result, the speaker grill 150 is fixed such that it is not outwardly separated from the main body case 120.

[0049] That is, the main body case constituted by the base body case 120 and the speaker panels 140 include inner walls 25 defining the attachment holes 44 connecting to the acoustic spaces 10 provided on the inner side. Each speaker grill 150 includes the projection sections 56 inserted into the attachment holes 44 such that the distal ends 568 project from the through holes 44 to the corresponding acoustic space side. Each elastic member 58 covers the distal end 56S of the corresponding projection section 56 and one portion 58N thereof is arranged between the inner wall 25 of the corresponding attachment hole 44 and the projection section 56 in the attachment hole 44. The other portion 58S of the elastic member 58 covering the distal end 56S of the projection section 56 and one portion of the distal end 56S are arranged in space O located outside space I surrounded by the extended line of the inner wall 25. As a result, the speaker grill 150 is fixed to the main body case 120.

[0050] The attachment holes 46 provided outside the panel-side sealed frame sections 42 have no effect on the sealability of each acoustic space 10, and therefore the projection sections 56 corresponding to these attachment holes 46 are engaged with the speaker panels 140 without elastic members by torsion deformation of the distal ends exposed from the attachment holes 44.

[0051] In the present embodiment, the linear grooves 36 are provided on the upper surface side of each speaker panel 140, and the convex areas 37 are provided inside the speaker panels 140 so as to ensure the thickness of the portions provided with the linear grooves 36. Therefore, the periphery of each attachment hole 44 or 46 where each projection section 56 of the corresponding speaker grill 150 protrudes in the corresponding speaker panel 140 projects more greatly as compared to the other members. As a result, the twisting work of each projection section 56 is facilitated, which enhances the work efficiency.

[0052] Also, in the present embodiment, the speaker grills 150 are fixed to the speaker panels 140 by torsion deformation of the projection sections 56 of the speaker grills 150 exposed from the attachment holes 44 and 46 provided in the linear grooves 36 on the upper surfaces of the speaker panels

**140.** As a result, the projection sections **56** to be subjected to torsion deformation and scratches on the inner side which may be made during work can be hidden from the outside, whereby high-quality design can be maintained.

**[0053]** Note that, as the material of the elastic members **58** of the present embodiment, a resin material such as silicon can be favorably used. Also, the shape of each elastic member **58** may be a shape by which the corresponding projection section **56** including its distal end can be entirely covered as shown in FIG. 7A, or a shape whose portion near the base of the corresponding projection section **56** projects to have a flange shape or a brim shape as shown in FIG. 7B, in addition to the shape shown in FIG. 5A and FIG. 6A. Moreover, each elastic member **58** may have a shape by which the distal end of the corresponding projection section **56** is exposed and the elastic member is positioned only inside the corresponding attachment hole **44** having the hole rib **48**, as shown in FIG. 6C.

**[0054]** Also, the material and structure of each speaker grill **150** is required have sufficient strength to protect at least the sound emission surfaces of the corresponding speaker **130** and the corresponding tweeter **32**. Accordingly, for example, a metal material such as aluminum is applied to each speaker grill **150**. In addition, in the present embodiment, each speaker grill **150** should preferably be made from a material by which torsion deformation applied on the projection sections **56** when the speaker grills **150** are fixed on the speaker panels **140** can be reversibly returned to the original state or a material by which each projection section **56** can be untwisted to the extent that the projection sections **56** can be removed from the attachment holes **44** and **46** of the speaker panels **140**. As a result, the speaker grills **150** attached and fixed to the speaker panels **140** can be detached, so that repair at the time of malfunction, maintenance at the time of part replacement, segregation recycle at the time of product disposal can be satisfactorily carried out. In particular, the present invention has superior effects as compared to device cases such as musical instrument cases or speaker cases where speaker grills are irreversibly attached by welding.

**[0055]** As such, in the present embodiment, the projection sections **56** are subjected to torsion deformation with each elastic member **58** being interposed between the corresponding attachment hole **44** provided in one of the panel-side sealed frame sections **42** demarcating the acoustic spaces **10** and the corresponding projection section **56**. As a result, the elastic member **58** is deformed inside the attachment hole **44** and comes in close contact with the surface of the projection section **56** and the inner surface of the attachment hole **44**, whereby the attachment hole **44** that is a through hole is filled. As a result of this structure, the speaker grills **150** can be engaged with and satisfactorily fixed to the speaker panels **140**, and the leakage of sound and air from the acoustic spaces **10** and the occurrence of vibration sound (chattering sound) between each speaker panel **140** and each speaker grill **150** can be prevented. Also, since the attachment holes **44**, which are used when the speaker grills **150** are attached to the speaker panels **140**, can be arranged at positions where they penetrate to the acoustic spaces **10**, the degree of freedom in a design related to the attachment structure of the speaker grills **150** can be enhanced, and the attachment area can be reduced, which contributes to the downsizing of the musical instrument case of an electronic keyboard instrument.

**[0056]** Also, in the present embodiment, the above-described hole rib **48** having a thick portion or a thick member is provided around each attachment hole **44** or **46**, and the attachment holes **44** and **46** are arranged near the reinforcement ribs **40** for maintaining the housing strength of each speaker panel **140**, whereby the strength with respect to stress to be applied to the attachment holes **44** and **46** and nearby portions when the projection sections **56** of the speaker grills **150** are subjected to torsion deformation can be enhanced and the breakage of the parts can be prevented. Moreover, since the inner area of each attachment hole **44** or **46** can be increased, each elastic member **58** interposed between the inner wall of the corresponding attachment hole **44** or **46** and the corresponding projection section **56** of the speaker grills **150** comes in close contact with a wide area of the inner wall of the attachment hole **44**, **46**, whereby the attachment hole **44** is substantially completely filled. As a result, the leakage of sound and air from the acoustic spaces **10** and the occurrence of vibration sound (chatter sound) between each speaker **140** and the corresponding speaker grill **150** can be favorably prevented.

**[0057]** <Assembly Method for Electronic Keyboard Instrument>

**[0058]** Next, an assembly method for the electronic keyboard instrument having the above-described structure is described. Here, in addition to the assembly method for the electronic keyboard instrument, the sealing structure of the acoustic space unique to the present embodiment is also described.

**[0059]** FIG. 8A to FIG. 11B are schematic diagrams showing an example of an assembly method for the electronic keyboard instrument according to the present embodiment, of which FIG. 8A, FIG. 8B and FIG. 9 are schematic diagrams showing an assembly method for mounting a speaker on a speaker panel, and FIG. 10A, FIG. 10B, FIG. 11A, and FIG. 11B are schematic diagrams showing an assembly method for mounting a speaker grill on the speaker panel. FIG. 12A and FIG. 12B are schematic diagrams showing an example of a packing applied to the base body case of the electronic keyboard instrument according to the present embodiment, and FIG. 13 is a schematic diagram showing an acoustic space defined in the electronic keyboard instrument according to the present embodiment. FIG. 14A and FIG. 14B are schematic diagrams showing an example of the case structure of the speaker panel of the electronic keyboard instrument according to the present embodiment, and FIG. 15A to FIG. 15C are schematic diagrams showing an example of a sealing structure in the assembled state of the electronic keyboard instrument according to the present embodiment.

**[0060]** In the assembly method for the electronic keyboard instrument according to the present embodiment, first, one of the speakers **130** is mounted on and fixed to the speaker mounting section of the corresponding speaker panel **140** by screws, as shown in FIG. 8A and FIG. 8B. Then, a speaker cover **50** is fixed by screws to the upper surface (sound emission surface side) of the speaker panel **140** to which the speaker **130** has been attached, as shown in FIG. 9.

**[0061]** Next, the edge side sections **54a** of the outer peripheral sections **54** of one of the speaker grills **150** are fitted into the linear grooves **36** provided in the upper surface of the speaker panel **140**, so that the attachment position of the speaker grill **150** with respect to the speaker panel **140** is determined and the projection sections **56** projecting from

the outer peripheral sections 54 are inserted into the attachment holes 44 and 46 provided in the linear grooves 36, as shown in FIG. 10A and FIG. 10B. Then, the elastic members 58 are inserted and attached to the projection sections 56 exposed from the attachment holes 44 having the hole ribs 48 in the speaker panel 140 or the attachment hole 44 provided in the thick member, as shown in FIG. 11A and FIG. 11B. Here, the elastic members 58 are attached to the projection sections 56 such that each elastic member 58 is interposed between the corresponding attachment hole 44 and the corresponding projection section 56. Then, the distal ends of the projection sections 56 exposed to the inside of the speaker panel 140 are subjected to torsion deformation so as to hold and fix the speaker grill 150 on the speaker panel 140, and the elastic members 58 are deformed inside the attachment holes 44 so as to fill the attachment holes 44 that are through holes, as shown in FIG. 5C.

[0062] The speaker panels 140 where the speakers 130 and the speaker grills 150 have been mounted as described above are then attached to the left and right end areas of the back side portion of the base body case 120. Here, the panel-side sealed frame section 42 of each speaker panel 140 comes in close contact with the corresponding base-body-side sealed frame section 24 via a packing 12 provided extending on the upper end of the base-body-side sealed frame section 24 in the base body case 120, as shown in FIG. 12A and FIG. 12B. As a result, as shown in FIG. 13, each space (shown with a thick line in the drawing) surrounded by one of the base-body-side sealed frame sections 24 of the base body case 120 and the panel-side sealed frame section 42 of one of the speaker panels 140 is sealed and demarcated as an acoustic space 10.

[0063] In the case of an acoustic space demarcated as described above, even when an attachment hole of a speaker grill is provided penetrating to the acoustic space, the attachment hole can be filled by an elastic member. Therefore, the leakage of sound and air from the acoustic space and the occurrence of vibration sound (chatter sound) can be prevented, whereby the sealability can be ensured. Accordingly, sound waves emitted from a speaker provided in a speaker panel can be favorably echoed in the sealed acoustic space, which improves the sound quality. Also, the attachment area of the speaker grill can be reduced, which contributes to the downsizing of the musical instrument case of an electronic keyboard instrument.

[0064] In the above-described assembly method for the electronic keyboard instrument, the projection sections 56 of the speaker grills 150 are inserted into the attachment holes 44 of the speaker panels 140, and then the elastic members 58 are attached to the projection sections 56 and subjected to torsion deformation. However, the present invention is not limited thereto. That is, it is only required that each elastic member 58 is between the corresponding attachment hole 44 and the corresponding projection section 56 at timing at which the projection sections 56 of the speaker grills 150 are inserted into the attachment holes 44 of the speaker panels 140 (timing immediately before torsion deformation). Accordingly, a method may be adopted in which, after the elastic members 58 shown in FIG. 7A or FIG. 7C are attached to the projection sections 56 of the speaker grills 150, the projection sections 56 in this state are inserted into the attachment holes 44 of the speaker panels 140, and the distal ends thereof are subjected to torsion deformation. Also, a method may be adopted in which the elastic mem-

bers 58 each of which has a shape whose base portion projects to have a flange shape or a brim shape as shown in FIG. 7B are inserted into the attachment holes 44 of the speaker panels 140, and then the projection sections 56 of the speaker grills 150 are inserted into the attachment holes 44 (in the elastic members 58).

[0065] <Specific Example of Sealing Structure>

[0066] Next, a specific example of the sealing structure of the acoustic space applied to the electronic keyboard instrument described above is described.

[0067] FIG. 14A and FIG. 14B are schematic diagrams showing a main portion of the speaker panel applied to the electronic keyboard instrument according to the present embodiment, and FIG. 15A to FIG. 15C are schematic diagrams showing a main portion of the sealing structure applied to the electronic keyboard instrument according to the present embodiment.

[0068] As described above, in the sealing structure in the present embodiment, the panel-side sealed frame sections 42 in the speaker panels 140 come in close contact with the packing 12 provided extending on the upper ends of the base-body-side sealed frame sections 24 in the base body case 120 as shown in FIG. 12B, so that each space surrounded by the corresponding base-body-side sealed frame section 24 of the base body case 120 and the panel-side sealed frame section 42 of the corresponding speaker panel 140 is sealed and demarcated as an acoustic space 10, as shown in FIG. 13.

[0069] In cases where the panel-side sealed frame sections 42 have shapes by which they evenly come in close contact with the packing 12 provided on the upper ends of the base-body-side sealed frame sections 24, the sealability of each acoustic space 10 is sufficiently ensured. However, there is a case where the panel-side sealed frame sections 42 having the shapes by which they favorably come in close contact with the packing 12 on the upper ends of the base-body-side sealed frame sections 24 are not actualized due to, for example, the design of the product, the layout of the members provided inside, restrictions in the metallic molding technique and the like. The present embodiment applies to this case and has the structure where the speaker panels 140 are designed to be slightly larger than the outer shape of the base body case 120 and, in a state where the speaker panels 140 have been mounted on the base body case 120, each speaker panel 140 projects outward in a peaked roof shape with respect to the outer edge of the base body case 120 such that it especially projects at case corners.

[0070] Accordingly, in the present embodiment, a corner rib 14 is provided near a corner (details of portion B) of the outer-peripheral-side frame section 42a of the panel-side sealed frame section 42 of each speaker panel 140, as shown in FIG. 14A and FIG. 14B. This corner rib 14 is independently projected from the bottom surface of the speaker panel 140 (the speaker attachment surface or the opposite surface of the speaker grill attachment surface) on the lower side in the drawing toward the upper side in the drawing (open end direction), in substantially parallel to the outer-peripheral-side frame section 42a. The planar shape of the corner rib 14 when viewed from the upper side in the drawing is an arc-like shape or a gradually curved shape. On the other hand, the corresponding corner of the outer-peripheral-side frame section 42a has a planar shape that is bent at a substantially right angle.

[0071] The corner rib 14 includes reinforcement ribs 16a and 16b for enhancing the structural strength, which are provided on both ends of its arc-like planar shape and connected at a substantially right angle to the outer-peripheral-side frame section 42a, as shown in FIG. 14B. In a case where the speaker panels 140 are formed by resin molding, the corner rib 14 and the reinforcement ribs 16a and 16b are integrally formed with another portion such as the outer-peripheral-side frame section 42a and the bottom surface.

[0072] Also, in the upper parts of the reinforcement ribs 16a and 16b on the outer peripheral surface (surface opposing the outer-peripheral-side frame section 42a) side of the corner rib 14, notched sections 18 for holding the corresponding packing 12 or coming in close contact with the outer periphery of the packing 12 are provided, as shown in FIG. 14B.

[0073] Note that, in the structure of FIG. 14B, the reinforcement rib 16b also serves as a reinforcement rib 40 near the panel attachment boss 38 provided in the vicinity of the corner of the outer-peripheral-side frame section 42a. Also, the reinforcement ribs 16a and 16b are not required to have the structures where they connect the corner rib 14 and the outer-peripheral-side frame section 42a, and may have other structures. For example, the reinforcement rib 16b may have a structure where it is provided near the corner rib 14 regardless of the position of the panel attachment boss 38.

[0074] In the electronic keyboard instrument having the above-described structure, when the speaker panels 140 are attached to the base body case 120 as in the assembly method described above, the outer peripheral surfaces of the corner ribs 14 come in close contact with the packing 12 provided on the upper ends of the base-body-side sealed frame sections 24 in the base body case 120, at the corners of the panel-side sealed frame sections 42 where the corner ribs 14 are provided, as shown in FIG. 15A. That is, at these corners of the speaker panels 140, the outer peripheral surfaces of the corner ribs 14 come in close contact with the inner surfaces of the base-body-side sealed frame sections 24 in the base body case 120 via the packing 12.

[0075] At linear portions of each panel-side sealed frame section 42 other than the above-described corners, the inner surface of the panel-side sealed frame section 42 comes in close contact with the packing 12 of the corresponding base-body-side sealed frame section 24, as shown in FIG. 15B. Also, as shown in FIG. 15C, the end (lower end in the drawing) of each panel-side sealed frame section 42 comes in close contact with the packing 12 of the corresponding base-body-side sealed frame section 24. That is, in portions of the speaker panels 140 other than the above-described corners (where the corner ribs 14 are provided), the inner surfaces of the panel-side sealed frame sections 42 of the speaker panels 140 come in close contact with the outer surfaces of the base-body-side sealed frame sections 24 in the base body case 120 via the packing 12. Also, the lower ends of the panel-side sealed frame sections 42 of the speaker panels 140 come in close contact with the upper ends of the base-body-side sealed frame sections 24 via the packing 12.

[0076] As such, in the state where the speaker panels 140 have been mounted on the base body case 120, in all the attachment areas, the corner ribs 14 or the panel-side sealed frame sections 42 of the speaker panels 140 and the base-body-side sealed frame sections 24 of the base body case 120 come in close contact via the packing 12. Thus, in the

present embodiment, the leakage of sound and air of the acoustic space 10 can be prevented and the sealability can be ensured. Also, by the reinforcement ribs being provided integrally with or near the corner ribs 14, the structural strength can be enhanced and the sealability of the acoustic space 10 can be further enhanced.

[0077] In the above-described embodiment, the electronic keyboard instrument (electronic keyboard) has been described as an example of an audio device equipped with a device case according to the present invention. However, the present invention is not limited thereto, and can be applied to a stand-alone speaker, audio equipment and the like other than the electronic instrument.

[0078] While the present invention has been described with reference to the preferred embodiments, it is intended that the invention be not limited by any of the details of the description therein but includes all the embodiments which fall within the scope of the appended claims.

What is claimed is:

1. An audio device comprising:

a main body case having an inner wall defining a through hole connected to an acoustic space formed around at least one speaker provided inside the main body case;

a cover member having a projection section inserted into the through hole such that a distal end of the projection section projects to the acoustic space side from the through hole; and

an elastic member which covers the distal end of the projection section and whose at least one portion is arranged between the inner wall and the projection section in the through hole,

wherein at least one portion of the elastic member covering the distal end and at least one portion of the distal end are arranged in a space located outside a space surrounded by an extended line of the inner wall, whereby the cover member is fixed to the main body case.

2. The audio device according to claim 1, wherein the main body case has a thick portion which is provided around the through hole and projects to the acoustic space.

3. The audio device according to claim 3, wherein the cover member has the projection section on an outer periphery thereof,

wherein the main body case has a groove formed corresponding to a shape of the outer periphery and provided in an inner peripheral portion, and

wherein the through hole penetrates from an area outside the main body case to the acoustic space by being provided in a bottom surface of the groove.

4. The audio device according to claim 1, wherein the main body case has a sound emission section provided therein, and

wherein the acoustic space is a space where a sound wave emitted from the sound emission section is echoed.

5. The audio device according to claim 1, wherein the main body case includes a first housing whose inner corner has a first shape, and a second housing including a corner rib member provided at an inner corner and having a shape corresponding to the first shape, and

wherein the acoustic space is medially provided with respect to the corner rib member by the inner corner of the first housing coming in close contact with an outer side of the corner rib member of the second housing.

6. The audio device according to claim 5, wherein the main body case has a second elastic member provided extending along a boundary of the acoustic space so as to come in close contact with the first housing and the second housing.

7. An electronic instrument comprising:

operators for specifying pitches;

a main body case having an inner wall defining a through hole connected to an acoustic space which is formed around at least one speaker provided inside the main body case and in which a sound emitted from a sound emission section in response to an operation on an operator is echoed;

a cover member having a projection section inserted into the through hole such that a distal end of the projection section projects to the acoustic space side from the through hole; and

an elastic member which covers the distal end of the projection section and whose at least one portion is arranged between the inner wall and the projection section in the through hole,

wherein at least one portion of the elastic member covering the distal end and at least one portion of the distal end are arranged in a space located outside a space surrounded by an extended line of the inner wall, whereby the cover member is fixed to the main body case.

8. The electronic instrument according to claim 7, wherein the main body case has a thick portion which is provided around the through hole and projects to the acoustic space.

9. The electronic instrument according to claim 7, wherein the cover member has the projection section on an outer periphery thereof,

wherein the main body case has a groove formed corresponding to a shape of the outer periphery and provided in an inner peripheral portion, and

wherein the through hole penetrates from an area outside the main body case to the acoustic space by being provided in a bottom surface of the groove.

10. The electronic instrument according to claim 7, wherein the main body case has the sound emission section provided therein, and

wherein the acoustic space is a space where a sound wave emitted from the sound emission section is echoed.

11. The electronic instrument according to claim 7, wherein the main body case includes a first housing whose inner corner has a first shape, and a second housing including a corner rib member provided at an inner corner and having a shape corresponding to the first shape, and

wherein the acoustic space is medially provided with respect to the corner rib member by the inner corner of the first housing coming in close contact with an outer side of the corner rib member of the second housing.

12. The electronic instrument according to claim 11, wherein the main body case has a second elastic member provided extending along a boundary of the acoustic space so as to come in close contact with the first housing and the second housing.

\* \* \* \* \*