



(19) **United States**

(12) **Patent Application Publication**
LIU

(10) **Pub. No.: US 2016/0271832 A1**

(43) **Pub. Date: Sep. 22, 2016**

(54) **NOVEL SOLAR AUTOCLAVE EQUIPMENT**

(71) Applicant: **Kai LIU**, QingDao, Shandong (CN)

(72) Inventor: **Kai LIU**, QingDao, Shandong (CN)

(21) Appl. No.: **14/414,634**

(22) PCT Filed: **Nov. 2, 2014**

(86) PCT No.: **PCT/CN2014/071954**

§ 371 (c)(1),

(2) Date: **Jan. 13, 2015**

Publication Classification

(51) **Int. Cl.**

B28B 11/24 (2006.01)

F26B 3/04 (2006.01)

(52) **U.S. Cl.**

CPC **B28B 11/245** (2013.01); **F26B 3/04** (2013.01)

(57) **ABSTRACT**

The present invention discloses novel solar autoclave equipment, which comprises an autoclave and a steam providing device, wherein said steam providing device is a solar heating device and comprises a plurality of vacuum tubes which are fixedly arranged outdoors and a connecting tube, a tubular water tank is installed in each said vacuum tube in an insertion manner, each said tubular water tank is in the shape of a straight tube with a closed lower end and an open upper end, the upper end of each said tubular water tank stretches out of said corresponding vacuum tube and is communicated with said connecting tube, and a space between the outer surface of the upper end of said tubular water tank and the inner wall of the upper end of said corresponding vacuum tube is sealed; and an inlet of said connecting tube is connected with a condensate water drain outlet of said autoclave, and an outlet of said connecting tube is connected to a steam input port of said autoclave through a compressor. The present invention uses the compressor to depressurize the solar heating device to obtain steam, the steam is pumped into the autoclave and condensed to release heat to provide corresponding temperature and pressure to the autoclave, and thus the solar heating device can be applied on autoclave equipment.

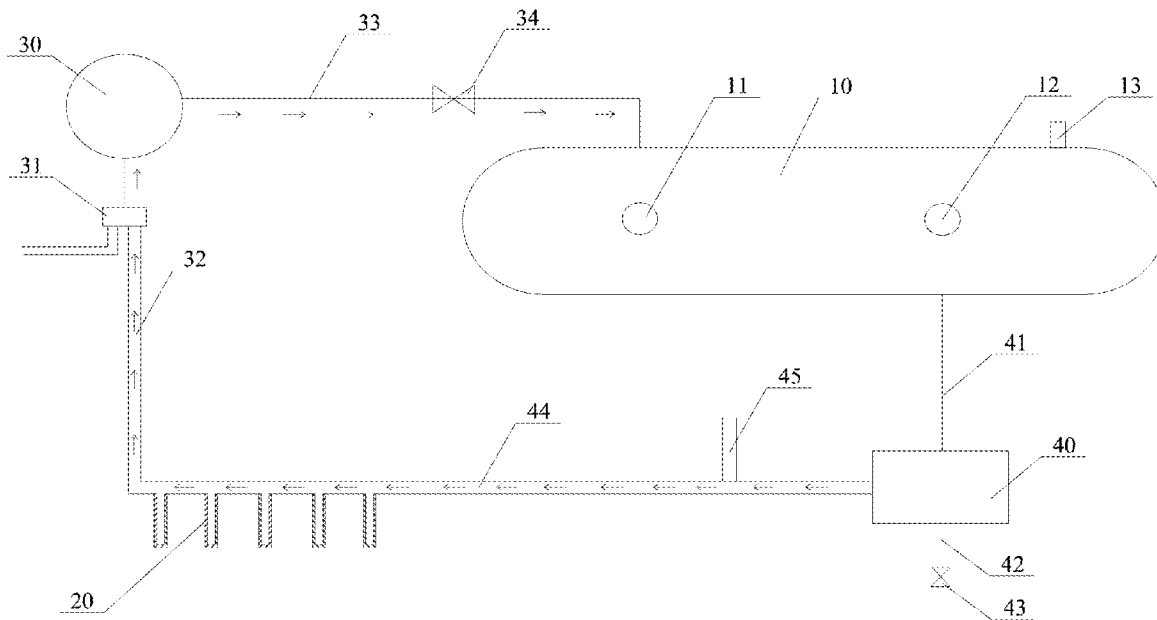

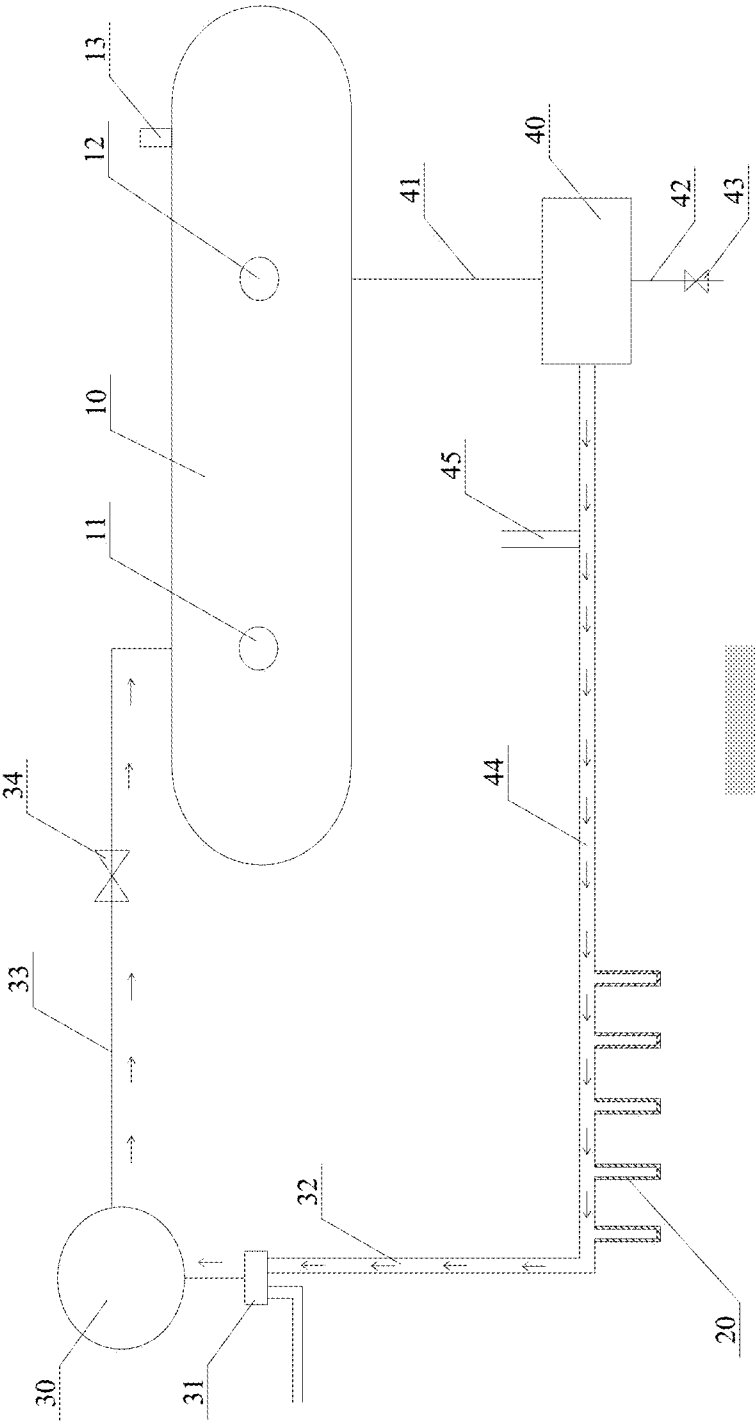

Fig. 1

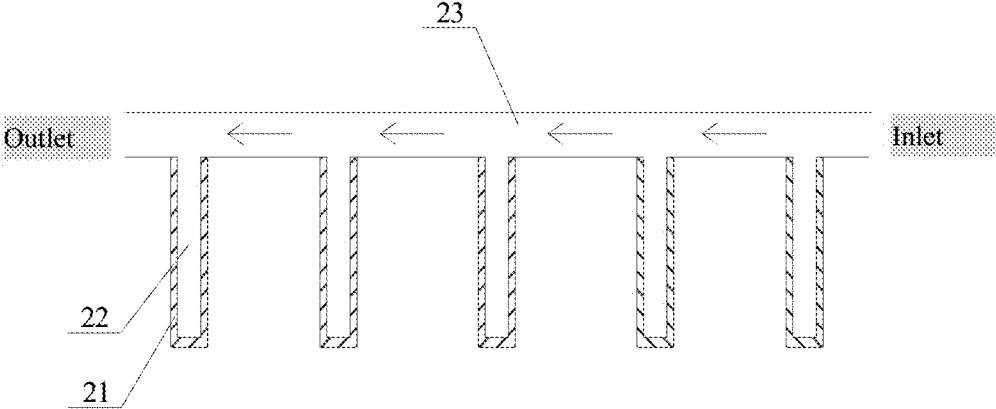

Fig. 2

NOVEL SOLAR AUTOCLAVE EQUIPMENT

FIELD OF THE INVENTION

[0001] The present invention relates to autoclave equipment, in particular to novel solar autoclave equipment.

BACKGROUND OF THE INVENTION

[0002] The application of autoclave equipment is very wide, such as autoclave curing of building materials such as aerated concrete blocks, coal ash bricks, microporous calcium silicate boards, novel light wall body materials, heat insulating asbestos boards and high-strength gypsum. Moreover, the autoclave equipment is also widely applied to rubber product and wood drying and anticorrosion treatment, heavy metal smelting, chemical fiber high-pressure treatment, cable vulcanization, and production projects which need pressure autoclave curing in chemical industry, pharmaceutical industry, aerospace industry, heat insulating material industry, textile industry, military industry, etc.

[0003] The autoclave equipment mainly consists of several parts such as an autoclave, a steam providing device and a safety control device. By taking the autoclave curing of the aerated concrete blocks as an example, the aerated concrete blocks are placed in the autoclave, the steam providing device provides high temperature and high pressure steam to the autoclave, the aerated concrete blocks finish $\text{CaO-SiO}_2\text{-H}_2\text{O}$ hydrothermal reaction in the autoclave to complete the autoclave curing. At present, the steam providing device mainly adopts a boiler boiling method to provide high temperature and high pressure steam, i.e., water is heated to obtain expanded water steam, so as to provide the autoclave with the steam and pressure. Since the water expansion and pressurization process needs to consume a great amount of energy, the energy consumption of the steam providing device of the existing autoclave equipment during working is huge.

[0004] As everyone knows, nowadays the energy crisis has already become a significant problem which hinders the development of global economy. Clean renewable energy such as solar energy is an important means to solve the energy crisis. However, since the efficiency of realizing water expansion and pressurization of solar equipment is very low, the solar equipment cannot be applied to the autoclave equipment.

SUMMARY OF THE INVENTION

[0005] The technical problem to be solved by the present invention is a problem that the autoclave equipment cannot utilize solar energy to provide high temperature and high pressure steam.

[0006] In order to solve the above-mentioned technical problem, the technical solution adopted by the present invention is to provide novel solar autoclave equipment, which comprises an autoclave and a steam providing device, wherein said steam providing device is a solar heating device and comprises

a plurality of vacuum tubes which are fixedly arranged outdoors, wherein a tubular water tank is installed in each said vacuum tube in an insertion manner, each said tubular water tank is in the shape of a straight tube with a closed lower end and an open upper end, the upper end of each said tubular water tank stretches out of said corresponding vacuum tube, and a space between the outer surface of the upper end of said

tubular water tank and the inner wall of the upper end of said corresponding vacuum tube is sealed; and a connecting tube, wherein the upper end of each tubular water tank is communicated with said connecting tube, an inlet of said connecting tube is connected with a condensate water drain outlet of said autoclave and an outlet of said connecting tube is connected to a steam input port of said autoclave through a compressor.

[0007] In the above-mentioned solution, said plurality of vacuum tubes are arranged in a row.

[0008] In the above-mentioned solution, said plurality of vacuum tubes are arranged in a plurality of rows and are configured in an array, and connecting tubes connected with said tubular water tanks in each row are sequentially connected in a head-to-tail manner to form a serial structure or are connected to form a reticular structure.

[0009] In the above-mentioned solution, said vacuum tubes are vertically or obliquely arranged.

[0010] In the above-mentioned solution, a reversing valve is arranged at the inlet of said compressor, a first inlet of said reversing valve is connected with the outlet of said connecting tube through a first pipeline, and a second inlet of said reversing valve is connected to the atmosphere.

[0011] In the above-mentioned solution, an outlet of said compressor is connected with the steam input port of said autoclave through a second pipeline, and a first flow control valve is arranged on said second pipeline.

[0012] In the above-mentioned solution, said condensate water drain outlet is connected to a water tank through a third pipeline, the bottom of said water tank is provided with a sewage drain pipe, and the inlet of said connecting tube is connected to the upper part of said water tank through a fourth pipeline.

[0013] In the above-mentioned solution, a safety valve is arranged on said autoclave and used for controlling the maximum internal pressure of said autoclave.

[0014] The present invention uses the compressor to depressurize the solar heating device to obtain steam, the steam is pumped into the autoclave and is condensed to release heat to provide corresponding temperature and pressure to the autoclave, and thus the solar heating device can be applied on autoclave equipment; and besides, the solar heating device adopts the tubular water tanks which are respectively installed in the plurality of vacuum tubes in an insertion manner to collect, water in each tubular water tank is heated, does not flow away and just exchanges heat with water, and thus the normal working of the solar autoclave equipment is guaranteed.

DESCRIPTION OF THE DRAWINGS

[0015] FIG. 1 is a structural schematic view of the present invention.

[0016] FIG. 2 is a structural schematic view of a steam providing device in the present invention.

DESCRIPTION OF THE EMBODIMENTS

[0017] The present invention is further described below in details in conjunction with specific embodiments and the drawings.

[0018] As shown in FIG. 1, novel solar autoclave equipment provided by the present invention comprises an autoclave 10 and a steam providing device 20, wherein the autoclave 10 is used for conducting autoclave curing to materials

such as aerated concrete blocks, the steam providing device **20** is used for providing high temperature and high pressure steam to the autoclave **10**, and the steam providing device **20** is a solar heating device.

[0019] As shown in FIG. 2, the solar heating device comprises a plurality of vacuum tubes **21**, the vacuum tubes **21** are vertically arranged and are fixedly arranged outdoors, and the number of the vacuum tubes **21** is generally determined according to actual needs.

[0020] A tubular water tank **22** is installed in each vacuum tube **21** in an insertion manner, each tubular water tank **22** is in the shape of a straight tube with a closed lower end and an open upper end, the upper end of each tubular water tank **22** stretches out of the corresponding vacuum tube **21**, a space between the outer surface of the upper end of each tubular water tank **22** and the inner wall of the upper end of the corresponding vacuum tube **21** is sealed, the plurality of vacuum tubes are arranged in a row or arranged in a plurality of rows in an array, the upper ends of the tubular water tanks **22** in each row are respectively communicated through one connecting tube **23** to form a parallel connected structure, connecting tubes **23** connected with the tubular water tanks **22** in each row are sequentially connected in a head-to-tail manner to form a serial structure or are connected to form a reticular structure, and finally a connecting tube header with an inlet and an outlet is formed.

[0021] In the embodiment, the tubular water tanks **22** are made of stainless steel, copper or alloy materials. After each tubular water tank **22** is inserted into the corresponding vacuum tube **21**, the outer surface of the tubular water tank **22** is close to the inner wall of the vacuum tube **21**, at least one of the vacuum tube **21** and the tubular water tank **22** is coated with a solar energy selective absorbing coating layer, and thus solar energy is absorbed and converted into heat energy to heat the water in each tubular water tank **22**. If both the vacuum tubes **21** and the tubular water tanks **22** are coated with the solar energy selective absorbing coating layer, the utilization ratio of the solar energy can be further increased.

[0022] Then referring to FIG. 1, the inlet of the connecting tube **23** is connected with a condensate water drain outlet of the autoclave **10**, and the outlet of the connecting tube **23** is connected to a steam input port of the autoclave **10** through a compressor **30**.

[0023] A reversing valve **31** is arranged at the inlet of the compressor **30**, a first inlet of the reversing valve **31** is connected with the outlet of the connecting tube **23** through a first pipeline **32**, and a second inlet of the reversing valve **31** is connected to the atmosphere.

[0024] An outlet of the compressor **30** is connected with the steam input port of the autoclave **10** through a second pipeline **33**, and a first flow control valve **34** is arranged on the second pipeline **33**.

[0025] The condensate water drain outlet of the autoclave **10** is connected to a water tank **40** through a third pipeline **41**, the bottom of the water tank **40** is provided with a sewage drain pipe, and the inlet of the connecting tube **23** is connected to the upper part of the water tank **40** through a fourth pipeline **42**.

[0026] A safety valve **13** is arranged on the autoclave **10** and used for controlling the maximum internal pressure of the autoclave **10**.

[0027] The present invention is further provided with a water replenishing pipe **45** for replenishing water consumed

and lost during the operation of the equipment, and the water replenishing pipe **45** can be arranged on the connecting tube **23** or the water tank **40**.

[0028] The working process of the present invention is as follows:

[0029] The vacuum tubes **21** absorb the solar energy to heat the water in the tubular water tanks **22**, the compressor **30** works to enable the internal part of the steam providing device to become into a negative-pressure state, thus hot water in the connecting tube **23** quickly becomes into steam which is pumped into the autoclave **10**, the steam participates in reaction in the autoclave **10** and is condensed to release heat to conduct autoclave curing to materials such as aerated concrete blocks, and heat-containing condensate water back-flows through the connecting tube **23** to continuously participate in circulation to continuously release heat. Since the condensate water carries a great amount of heat, the amount of energy needed for regenerating steam is smaller and the energy utilization ratio is high.

[0030] In the present invention, the working manner of the solar heating device is different from the traditional solar heating manner. The traditional solar heating manner usually adopts U-shaped tubes and water flows and is heated in the U-shaped tubes. However, in the present invention, the water does not flow in the tubular water tanks **22**, thus the water is continuously heated. Moreover, since the internal part of the solar heating device is in the negative-pressure state, the heat thereof is absorbed in the water evaporation process and is taken away in the form of steam, which is pumped into the autoclave **10** and is condensed to release heat.

[0031] In addition, the present invention provides a complete protection device, which is specifically described as follows:

(1) when the internal temperature of the autoclave **10** is lower than a set value, the reversing valve **31** is switched to be communicated with the steam providing device **20**, steam in the connecting tube **23** continuously enters the autoclave **10** and thus the internal temperature of the autoclave **10** is continuously increased;

(2) when the internal temperature of the autoclave **10** is higher than the set value, the reversing valve **31** is switched to be communicated with the atmosphere, the compressor **30** inputs air into the autoclave **10** and does not input the steam any more, and thus the internal temperature of the autoclave **10** is not continuously increased any longer;

(3) when the internal pressure of the autoclave **10** is lower than a set value, the opening of the flow control valve **34** is increased, the air inlet amount of the autoclave **10** is increased and thus the internal pressure of the autoclave **10** is increased; and

(4) when the internal pressure of the autoclave **10** is higher than the set value, the opening of the flow control valve **34** is decreased, the air inlet amount of the autoclave **10** is decreased and thus the internal pressure of the autoclave **10** is decreased.

[0032] The above-mentioned reversing valve **31** and the flow control valve **34** are automatically controlled through a control unit, i.e., a temperature sensor **11** and a pressure sensor **12** continuously transmit the internal temperature and the internal pressure of the autoclave **10** to the control unit, and the control unit outputs corresponding control signals to the reversing valve **31** and the flow control valve **34** according to the internal temperature and the internal pressure of the autoclave **10**.

[0033] A pressure reducing valve **13** is further arranged on the autoclave **10**. When the internal pressure of the autoclave **10** is accidentally and instantaneously increased, the pressure reducing valve **13** is automatically opened to exhaust the steam in the autoclave **10** to guarantee the safe operation of the autoclave **10**.

[0034] In addition, the pressure reducing valve **13** can also be automatically controlled through the control unit. When the internal temperature or the internal pressure of the autoclave **10** always exceeds the set value within a period of time (such as **2** minutes, which can be set by a user according to actual needs), the control unit gives out a control signal, the pressure reducing valve **13** is opened to exhaust the gaseous steam in the autoclave **10**, thus the goal of reducing the internal temperature or the internal pressure of the autoclave **10** is achieved and the safe operation of the autoclave **10** is further guaranteed.

[0035] Compared with the existing technical solution, the technical solution provided by the present invention solves numerous problems which cannot be solved in the prior art, and has the following prominent advantages:

(1) The precedent of utilizing the internal environment of a heat pump system is creatively started by the present invention, the internal part of the autoclave is used as a condensing section of the heat pump system, and the temperature and pressure needed by the autoclave are obtained in the internal environment of the heat pump system. In the process, working medium (water/water steam) in the internal environment of the heat pump system is in direct contact with substances (products) to be acted, heat is transferred or chemical reaction happens and thus the efficiency is greatly improved.

(2) The present invention provides a method for obtaining steam and application in the autoclave field. The existing boiler boiling method adopts a process of heating water to obtain expanded water steam to provide the autoclave with steam and pressure, and the expansion and pressurization process consumes a great amount of energy. However, the present invention uses the compressor to depressurize the low temperature water source to obtain steam, which is then pumped into the autoclave and is condensed to release heat to obtain corresponding temperature and pressure. Since the solar energy is utilized to provide needed steam and pressure to the autoclave system, the energy is saved.

(3) A great amount of fossil fuel and electric power needs to be consumed in order to increase the pressure in the traditional boiler boiling method. However, in the solution provided by the present invention, corresponding pressure can be obtained at the same time when cyclic heat supply is realized and additional work is not necessarily done.

(4) Since the water in the tubular water tanks basically does not flow, the water is always heated by the vacuum tubes and the vacuum tubes are equivalent to a heat preserving container with a quite good effect, the loss of heat is reduced.

(5) In the existing autoclave method, fossil energy is directly or indirectly consumed and thus great pollution is caused. However, in the solution provided by the present invention, by using the solar heat energy, no pollution is caused during operation.

[0036] The present invention is not limited to the above-mentioned preferable embodiments. It shall be known to any one that, all technical solutions which are identical with or similar to the technical solution of the present invention and are obtained by making structural variations under the inspi-

ration of the present invention, should fall into the protection scope of the present invention.

What is claimed is:

1. A novel solar autoclave equipment, comprising an autoclave and a steam providing device, and characterized in that said steam providing device is a solar heating device and comprises:

a plurality of vacuum tubes which are fixedly arranged outdoors, wherein a tubular water tank is installed in each said vacuum tube in an insertion manner, each said tubular water tank is in the shape of a straight tube with a closed lower end and an open upper end, the upper end of each said tubular water tank stretches out of said corresponding vacuum tube, and a space between the outer surface of the upper end of said tubular water tank and the inner wall of the upper end of said corresponding vacuum tube is sealed; and

a connecting tube, wherein the upper end of each tubular water tank is communicated with said connecting tube, an inlet of said connecting tube is connected with a condensate water drain outlet of said autoclave and an outlet of said connecting tube is connected to a steam input port of said autoclave through a compressor.

2. The novel solar autoclave equipment according to claim **1**, characterized in that said plurality of vacuum tubes are arranged in a row.

3. The novel solar autoclave equipment according to claim **1**, characterized in that said plurality of vacuum tubes are arranged in a plurality of rows and configured in an array, and connecting tubes connected with said tubular water tanks in each row are sequentially connected in a head-to-tail manner to form a serial structure or are connected to form a reticular structure.

4. The novel solar autoclave equipment according to claim **1**, characterized in that said vacuum tubes are vertically or obliquely arranged.

5. The novel solar autoclave equipment according to claim **1**, characterized in that a reversing valve is arranged at the inlet of said compressor, a first inlet of said reversing valve is connected with the outlet of said connecting tube through a first pipeline, and a second inlet of said reversing valve is connected to the atmosphere.

6. The novel solar autoclave equipment according to claim **1**, characterized in that an outlet of said compressor is connected with the steam input port of said autoclave through a second pipeline, and a first flow control valve is arranged on said second pipeline.

7. The novel solar autoclave equipment according to claim **1**, characterized in that said condensate water drain outlet is connected to a water tank through a third pipeline, the bottom of said water tank is provided with a sewage drain pipe, and the inlet of said connecting tube is connected to the upper part of said water tank through a fourth pipeline.

8. The novel solar autoclave equipment according to claim **1**, characterized in that a safety valve is arranged on said autoclave and used for controlling the maximum internal pressure of said autoclave.

9. The novel solar autoclave equipment according to claim **1**, characterized in that the novel solar autoclave equipment further comprises a water replenishing pipe, which is used for replenishing water into said tubular water tanks.

10. The novel solar autoclave equipment according to claim **2**, characterized in that said vacuum tubes are vertically or obliquely arranged.

11. The novel solar autoclave equipment according to claim 3, characterized in that said vacuum tubes are vertically or obliquely arranged.

* * * * *