



US 20160273834A1

(19) **United States**

(12) **Patent Application Publication**

**Lacey**

(10) **Pub. No.: US 2016/0273834 A1**

(43) **Pub. Date: Sep. 22, 2016**

(54) **LAUNDRY TRANSPORT CONTAINER APPARATUS AND METHOD**

(52) **U.S. Cl.**  
CPC .. *F26B 9/06* (2013.01); *F26B 23/00* (2013.01)

(71) Applicant: **Bertram E. Lacey**, Frederick, MD (US)

(57) **ABSTRACT**

(72) Inventor: **Bertram E. Lacey**, Frederick, MD (US)

A laundry transport apparatus and method includes a container defining an interior area configured to accommodate a plurality of laundry carts, the container having a door movable between closed and open configurations to selectively allow access to the interior area. The apparatus includes a ventilation network to pass air to and from the interior area and the outside, the intake duct and the outlet duct in a thermal transfer configuration for a portion of their length to influence temperature of air passing through each duct, warmer air passing through one of the intake duct or the outlet duct becoming cooler and cooler air passing through another of the intake duct or the outlet duct becoming warmer. The ventilation network including a pathogen identification, containment and remediation apparatus to detect, isolate and treat potentially harmful material within the soiled laundry.

(21) Appl. No.: **14/664,776**

(22) Filed: **Mar. 20, 2015**

**Publication Classification**

(51) **Int. Cl.**  
*F26B 9/06* (2006.01)  
*F26B 23/00* (2006.01)

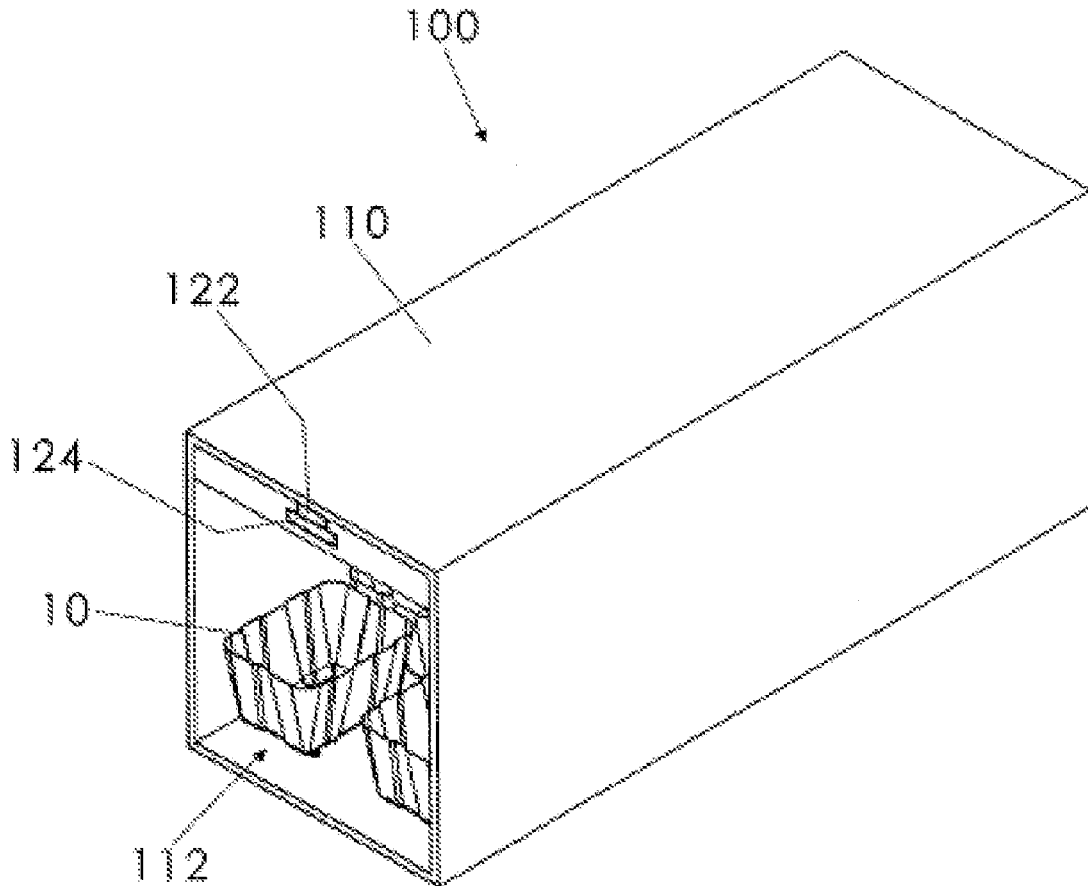

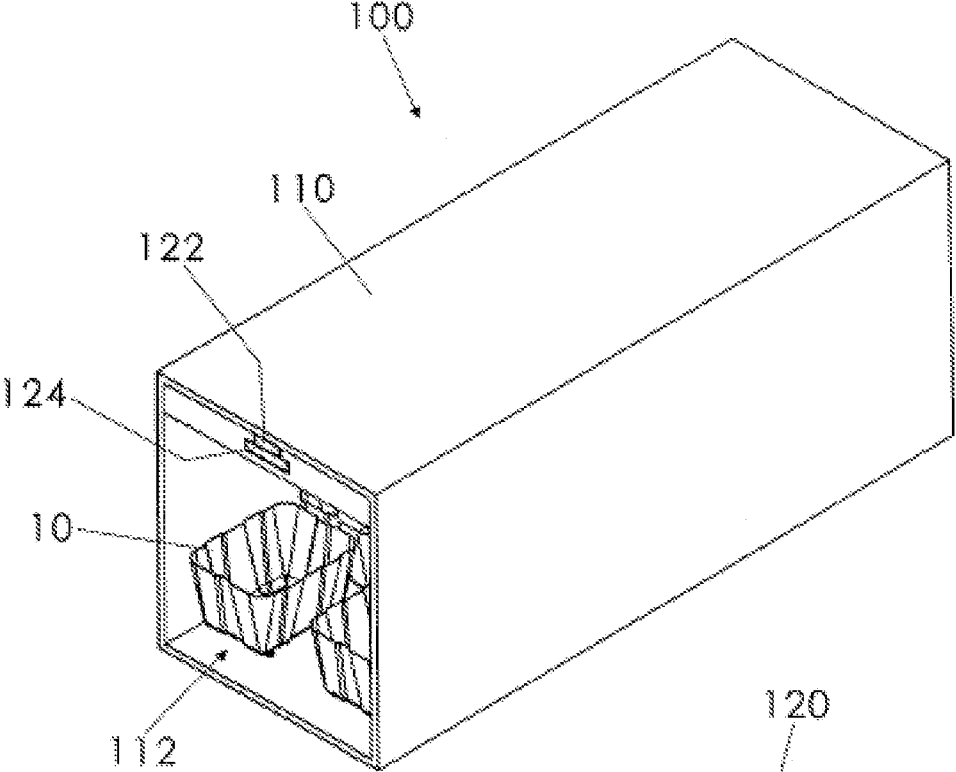

Fig. 1a

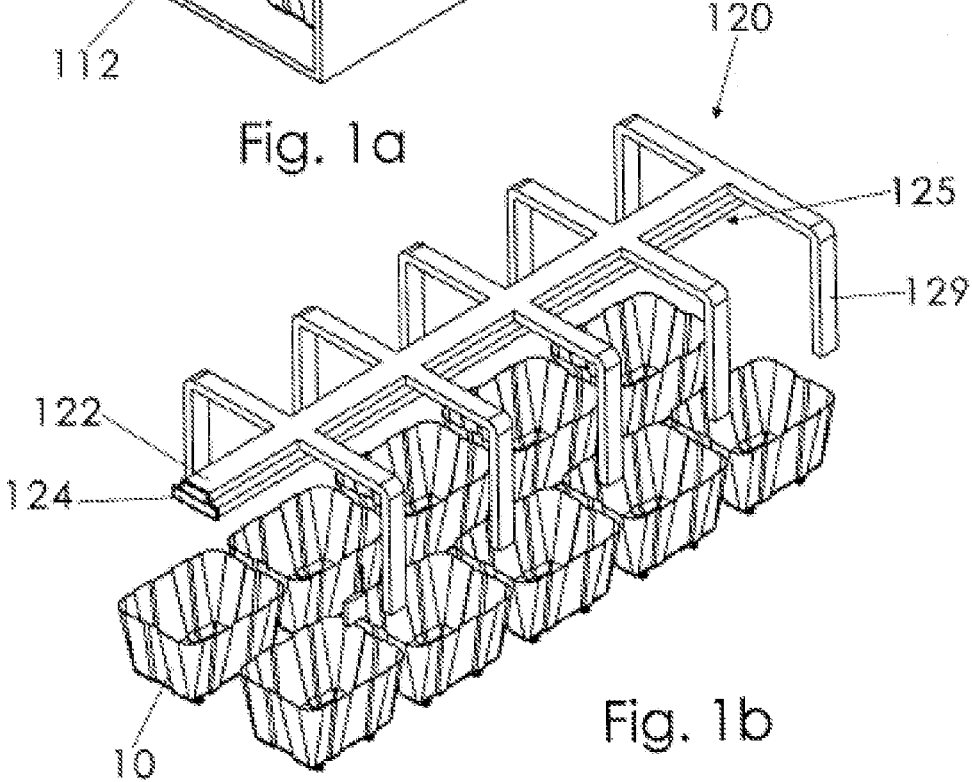

Fig. 1b

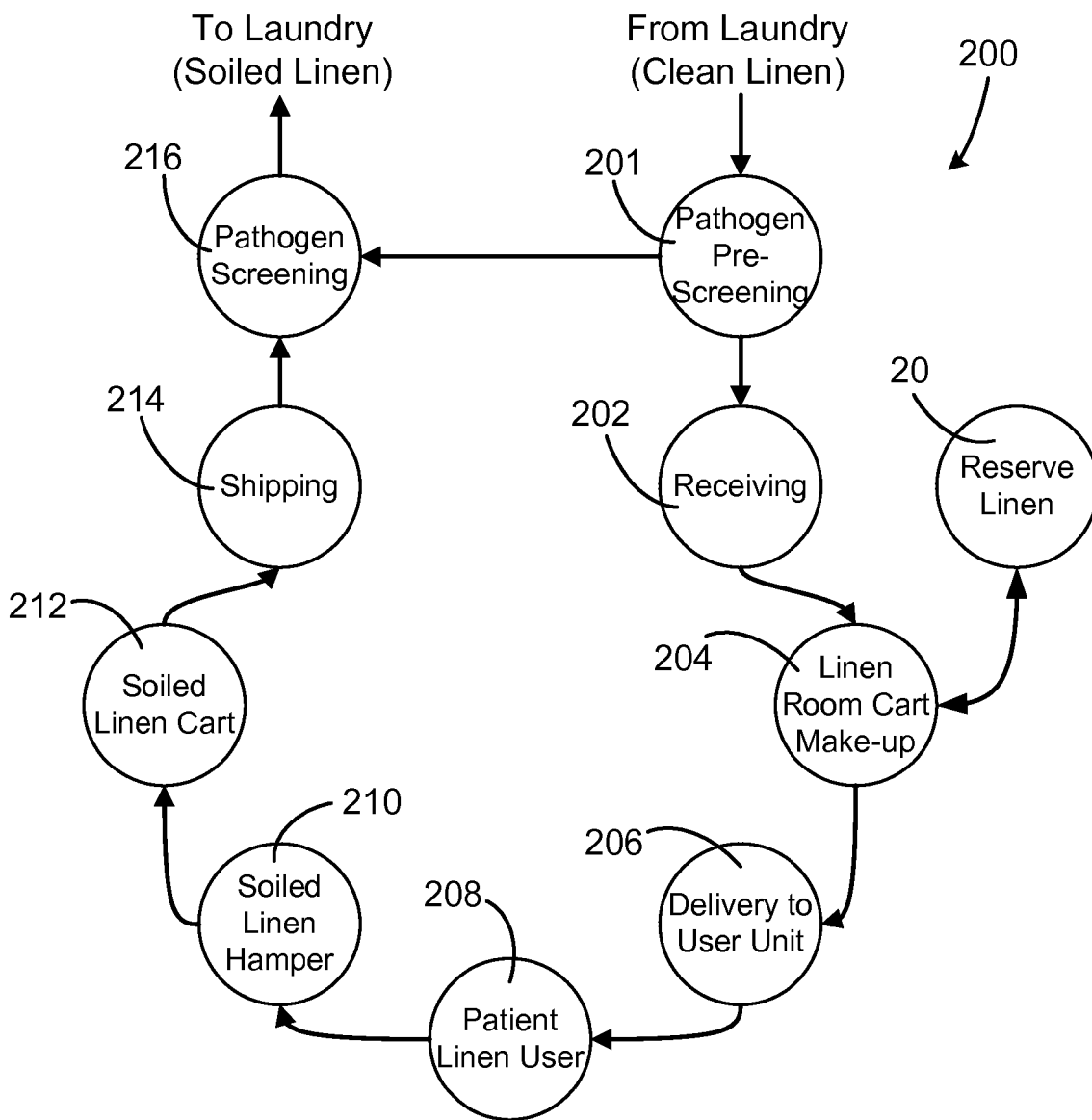

Fig. 2

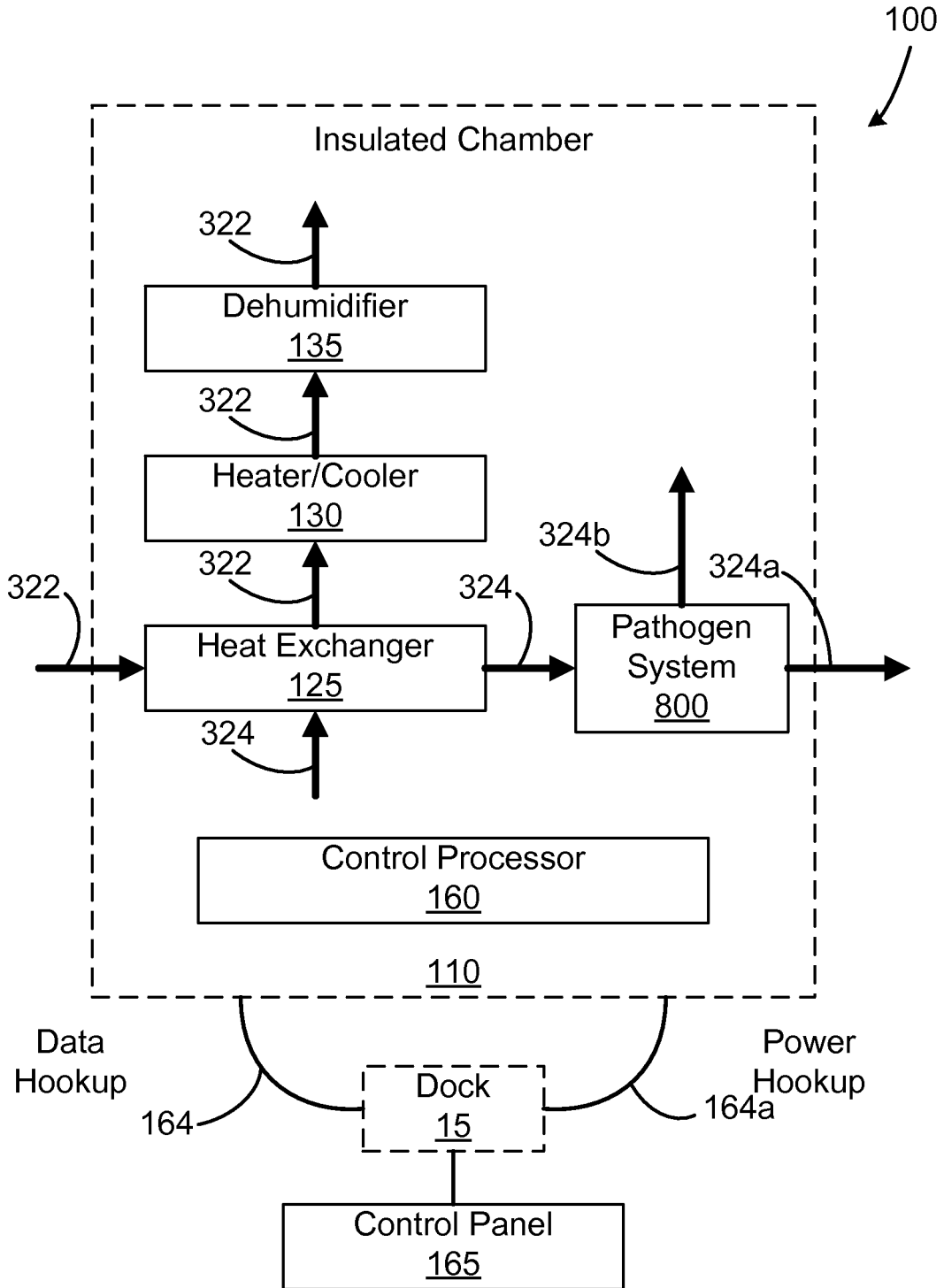

Fig. 3

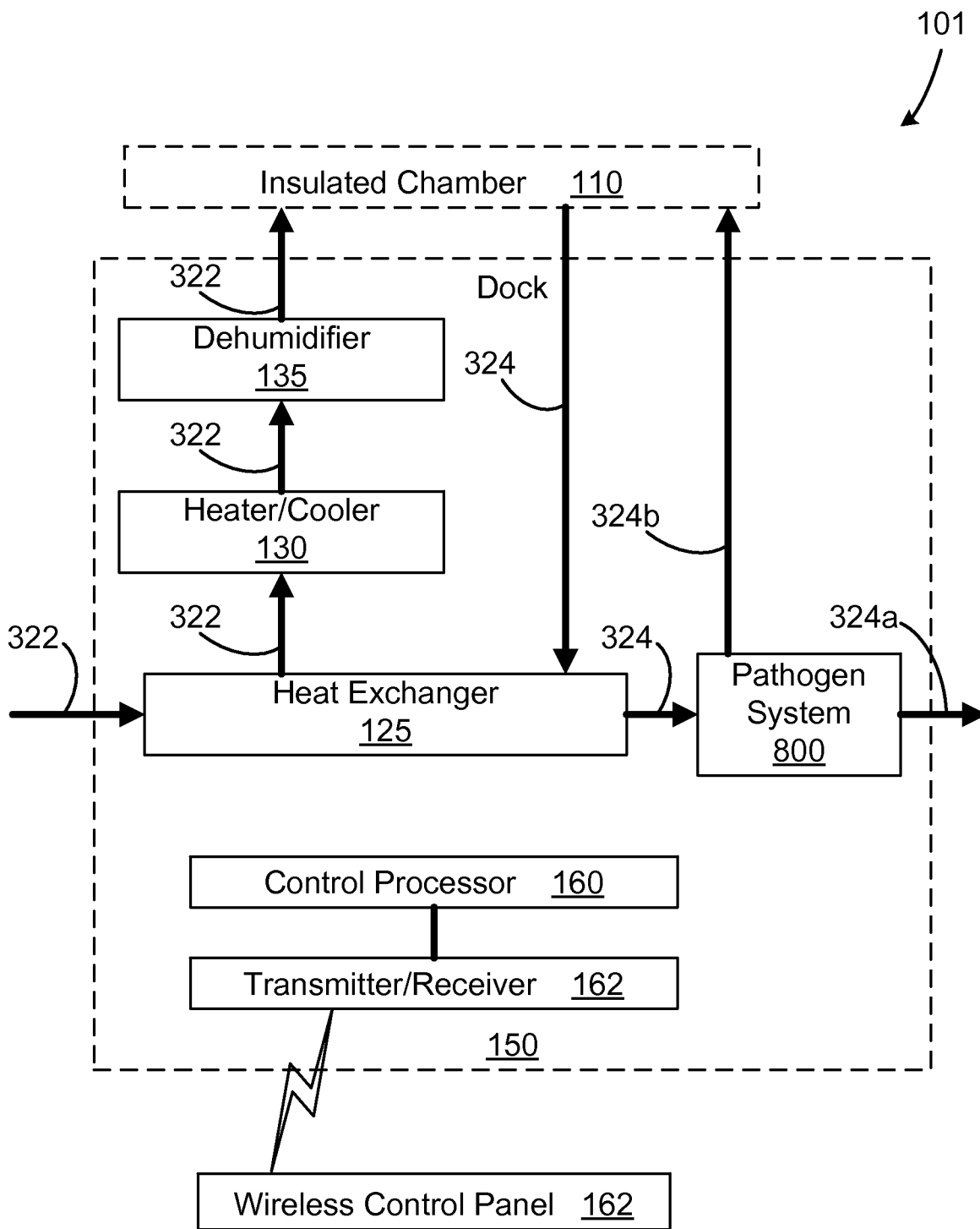

Fig. 4

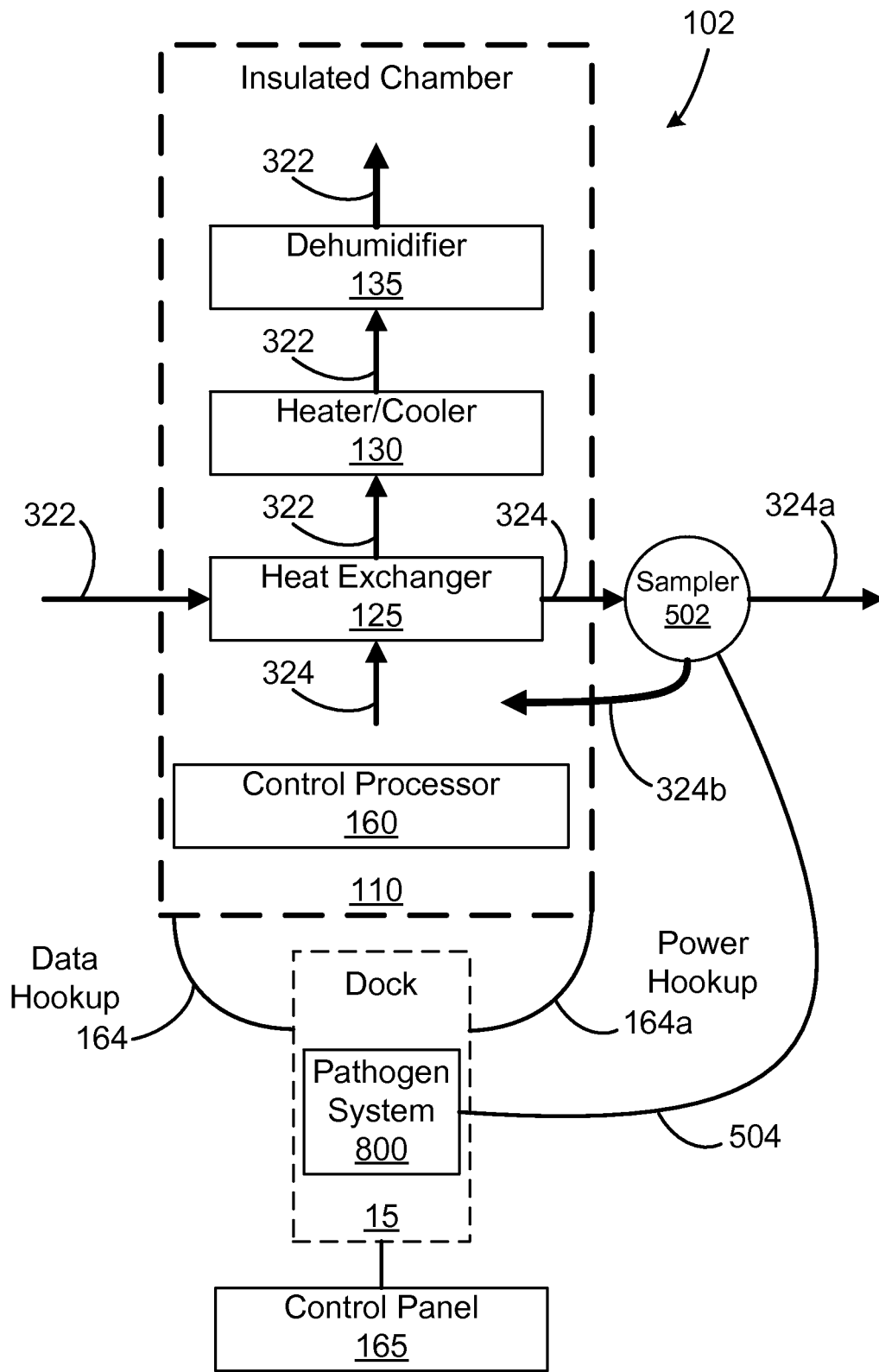

Fig. 5

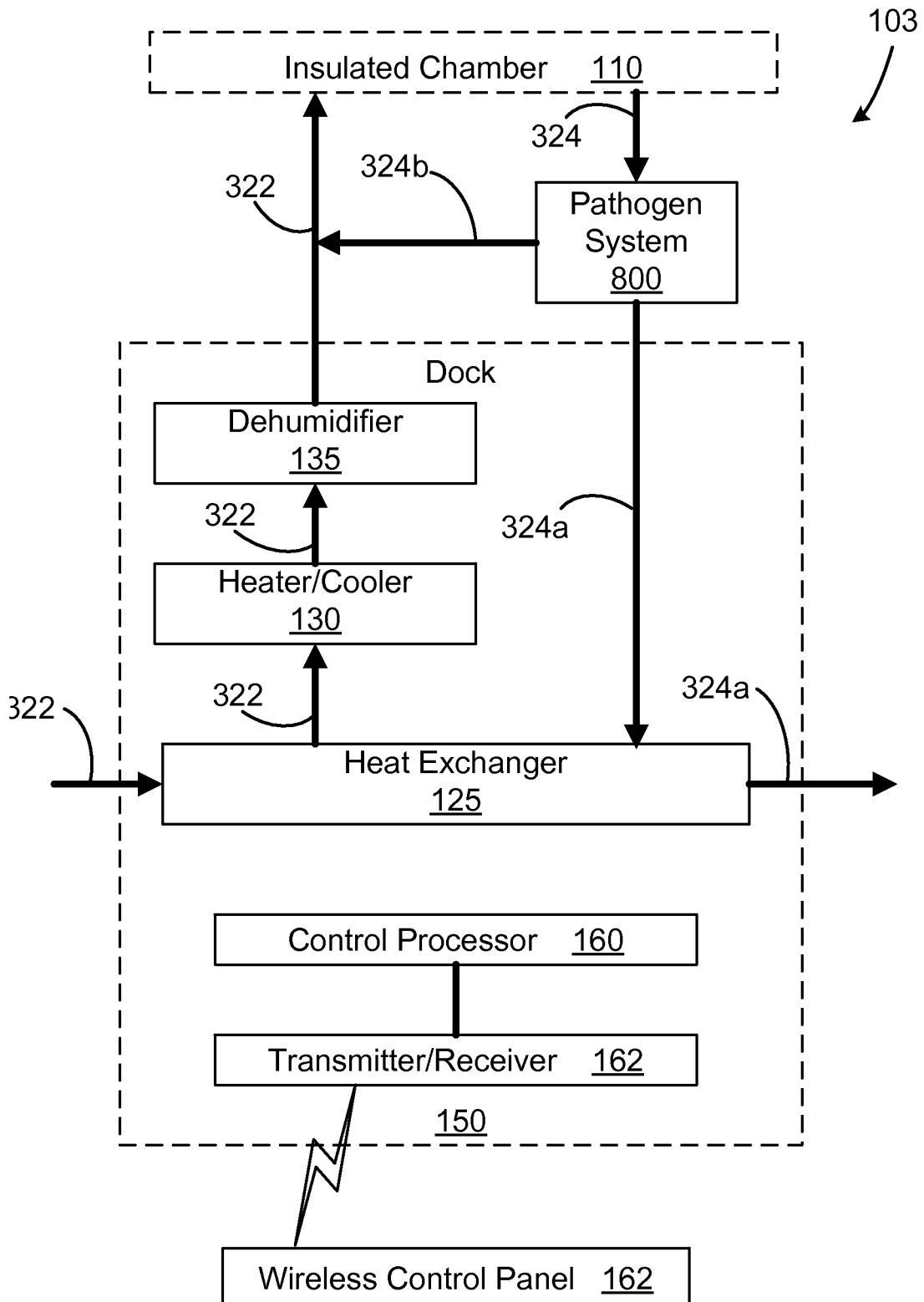

Fig. 6

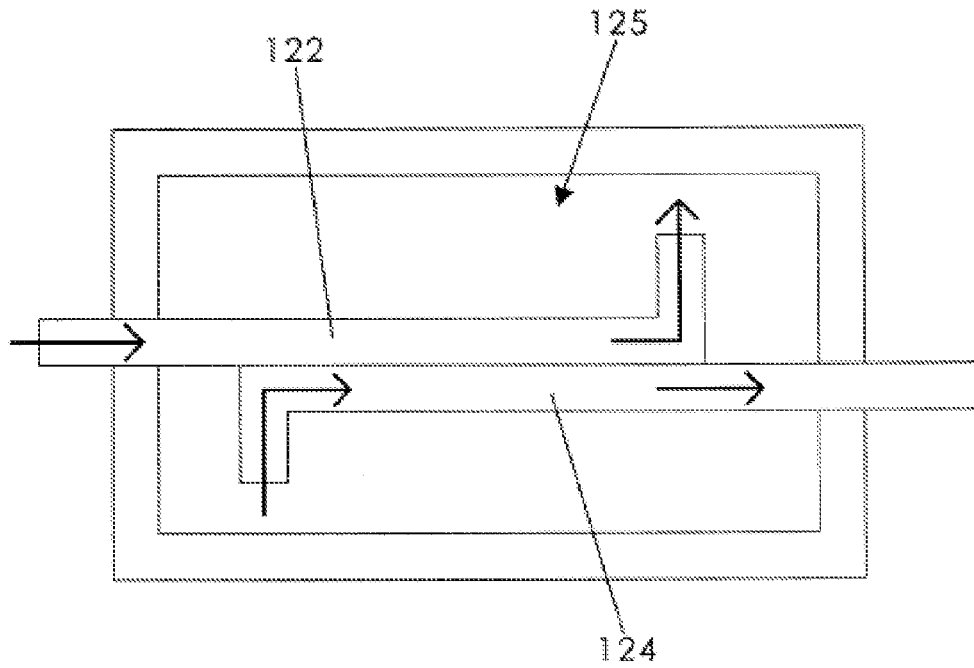

Fig. 7

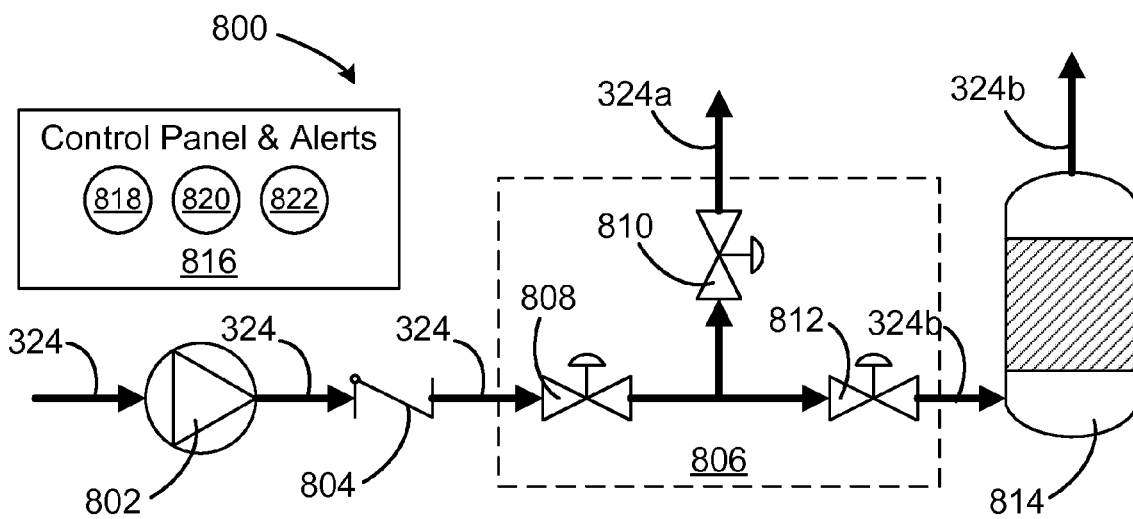

Fig. 8



## LAUNDRY TRANSPORT CONTAINER APPARATUS AND METHOD

### CROSS-REFERENCE TO RELATED APPLICATIONS

[0001] This application claims the benefit of non-provisional patent application Ser. No. 12/357,459, filed Jan. 22, 2009, and issue as U.S. Pat. No. 8,123,141 on Feb. 28, 2012, and non-provisional patent application Ser. No. 13/406,526, filed Feb. 27, 2012, and scheduled to issue as U.S. Pat. No. 8,985,475 on Mar. 24, 2015, both by the present inventor.

### BACKGROUND OF THE INVENTION

[0002] This invention relates generally to laundry systems and, more particularly, to a method and apparatus for transporting laundry that increases the efficiency and lowers the cost of laundering textiles, as well as provides identification, containment, and treatment of potentially harmful material within the soiled laundry.

[0003] Linens are typically collected from commercial users during normal working hours from multiple workstations, such as from hospitals, nursing facilities, or industrial facilities. The soiled linens are usually placed into linen carts that remain in predetermined locations throughout the facility. The linen carts are retrieved upon arrival of the laundry truck from a laundry processing facility and weighted prior to loading onto the truck. This process is very inefficient and may lead to delays for both the cleaning staff and the launderers. Another problem frequently experienced in laundry processing is that linens may not be properly stored and thus may become degraded by environmental factors such as ultraviolet light, moisture, temperature, insects, and textile mold and mildew.

[0004] Various devices have been proposed in the art for transporting and laundering textiles. Although assumedly effective for their intended purposes, the existing devices and methods are either inefficient, not cost effective, or fail to optimize the sanitation and freshness characteristics of the textiles being transported and laundered. For example, U.S. Pat. No. 7,310,969, titled "Controlled-Environment Cargo Container," issued to Robert Dale on Dec. 17, 2007, teaches an apparatus for controlling the environment of cargo through lateral ventilation. However, the prior art does not address, among other things, running inlet and outlet ducts adjacently in a thermal transfer configuration, which tends to reduce or eliminate condensation of moisture from the warmer air volume. Nor does the prior art teach the use and integration of a pathogen control system.

[0005] Therefore, it would be desirable to have an apparatus and method for transporting and laundering textiles that is efficient and cost-effective. Further, it would be desirable to have an apparatus and method for transporting and laundering textiles that provides a transportation apparatus that avoids degradation of stored linens from environmental factors. In addition, it would be desirable to have an apparatus and method for transporting and laundering textiles that provides security and insect control. Further, it would be a desirable addition to the art to provide thermal transfer configuration. And further still, it would be a desirable to provide an effective pathogen control system to the laundry transportation system.

### SUMMARY OF THE INVENTION

[0006] Therefore, a laundry transport apparatus and method according to the present invention includes a container defining an interior area configured to accommodate a plurality of laundry carts, the container having a door movable between closed and open configurations to selectively allow access to said interior area. The container is a trailer configured to be moved by a vehicle. The apparatus includes a ventilation network to pass air to and from the interior area, the ventilation network including an intake duct for channeling air to the interior area and an outlet duct for channeling air from the interior area. At least a portion of the intake and outlet ducts are immediately adjacent one another to influence temperature of air passing through each duct, warmer air passing through one of the intake duct or the outlet duct becoming cooler and cooler air passing through another of the intake duct or the outlet duct becoming warmer. The apparatus ventilation network may be coupled or coupleable to a pathogen system for detecting, containing, and treating potentially harmful pathogens, for example *Mycobacterium tuberculosis* (TB) and *Bacillus anthracis* (anthrax).

[0007] Therefore, a general object of this invention is to provide an apparatus and method for transporting and storing laundry that avoids degradation of linens by environmental conditions. Another object of this invention is to provide an apparatus and method, as aforesaid, having a container that is climate controlled. Still another object of this invention is to provide an apparatus and method, as aforesaid, that increases the efficiency and cost-effectiveness of laundry transportation and storage services. Yet another object of this invention is to provide an apparatus and method, as aforesaid, in which the laundry transport container is a truck trailer that is movable between pickup, processing, and receiving facilities. A further object of this invention is to provide an apparatus and method, as aforesaid, in which the transport trailer maintains an internal air environment that is controlled by a processor and may be remotely monitored. A further objective of this invention is to provide an apparatus and method, as aforesaid, in which the internal air environment may be monitored, isolated, and treated to isolate infectious diseases or pathogens. Other objects and advantages of the present invention will become apparent from the following description taken in connection with the accompanying drawings, wherein is set forth by way of illustration and example, embodiments of this invention.

### BRIEF DESCRIPTION OF THE DRAWINGS

[0008] FIG. 1a is a perspective view of a laundry transport container according to a preferred embodiment of the present invention;

[0009] FIG. 1b is a perspective view of a ventilation network removed from the laundry transport container as in FIG. 1a;

[0010] FIG. 2 is a flowchart illustrating a methodology for transporting, storage and pathogen monitoring of laundry according to the present invention;

[0011] FIG. 3 is a block diagram of an exemplary laundry transport apparatus in engagement with a dock at a linen receiving area;

[0012] FIG. 4 is a block diagram of an exemplary laundry transport apparatus according to another embodiment of the present invention;

[0013] FIG. 5 is a block diagram of an exemplary laundry transport apparatus according to another embodiment of the present invention;

[0014] FIG. 6 is a block diagram of an exemplary laundry transport apparatus according to another embodiment of the present invention;

[0015] FIG. 7 is a schematic of a heat exchanger according to the present invention; and

[0016] FIG. 8 is a schematic illustration of an exemplary pathogen system of an embodiment of the present invention.

#### DESCRIPTION OF THE PREFERRED EMBODIMENT

[0017] A laundry transport apparatus and a method of transporting laundry will now be described in detail with reference to FIG. 1a through FIG. 8 of the accompanying drawings. More particularly, exemplary laundry transport apparatuses 100, 101, 102, and 103, which include a container 110.

[0018] As shown in FIG. 1a, the container 110 defines an interior area 112 and has a door (not shown) for accessing the interior area 112. The door is movable between a closed configuration (not shown) and an open configuration (FIG. 1a) to selectively allow access to the interior area 112. The container 110 is configured to accommodate a plurality of laundry carts 10 in the interior area 112 (FIG. 1a). The container 110 may be a trailer configured to be moved by a vehicle (FIG. 1a) or may be otherwise mobile.

[0019] A ventilation network 120 is included to pass air to and from the interior area 112. The ventilation network 120 includes an intake duct 122 for channeling air 322 to the interior area 112 and an outlet duct 124 for channeling air 324 from the interior area 112. Apart from the ventilation network 120, the interior area 112 may be airtight when the door is at the closed configuration. One or more fan (not shown) may be configured (e.g., positioned and sized) to cause air to pass through the intake duct 122 and/or the outlet duct 124. More particularly, at least a portion of the intake duct 122 and outlet ducts 124 are arranged immediately adjacent one another to influence temperature of air passing through each duct 122, 124. Warmer air passing through one of the ducts 122, 124 becomes cooler from transferring energy to the cooler air passing through the other duct 122, 124, and the cooler air becomes warmer from obtaining the energy from the warmer air. This thermal transfer configuration tends to reduce or eliminate condensation of moisture from the warmer air volume. This configuration 125 performs a function similar to a heat exchanger device and may be referred to as such, though it differs from known heat exchangers in that a substantial portion of both the intake duct 122 and outlet ducts 124 are involved, while a standard heat exchanger works to accomplish the heat exchange in a compact interface. FIG. 7 shows an exemplary heat exchange configuration 125 between an intake duct 122 and an outlet duct 124.

[0020] As shown in FIGS. 3 through 6, a climate controller 130 (e.g., a heater and air conditioner) may be included for selectively heating and cooling air 322 passing through the intake duct 122 after the air 322 is influenced by air 324 passing through the outlet duct 124 to cause the air 322 passing through the intake duct 122 to approximate a temperature of air in the interior area 112 separate from the ventilation network 120. Also shown in FIGS. 3 through 6, a dehumidifier 135 may be included for removing humidity

from the air 322 passing through the intake duct 122 (e.g., after passing through the heat exchanger 125 and the climate controller 130).

[0021] In some embodiments, as shown in FIGS. 1b, 3, and 5, the portions of the intake and outlet ducts 122, 124 immediately adjacent one another are operatively coupled to the container 110 (e.g., above where the carts 10 are accommodated, as shown in FIG. 1b). Branches 129 from the intake and/or outlet ducts 122, 124 may extend downwardly toward the carts 10 (FIG. 1b). The climate controller 130 and the dehumidifier 135 may also be operatively coupled to the container 110 (FIGS. 3 and 5). In other embodiments, as shown in FIGS. 4 and 6, a control unit dock 150 is separate from the container 110, and the portions of the intake and outlet ducts 122, 124 immediately adjacent one another are operatively coupled to the control unit dock 150. Similarly, the climate controller 130 and/or the dehumidifier 135 may be operative coupled to the control unit dock 150 (FIGS. 4 and 6). If the control unit dock 150 is included, a portion of the ventilation network is coupled to the container 110 and another portion of the ventilation network is coupled to the control unit dock 150. These portions of the ventilation network are in selective communication with each other to allow air to pass to and from the interior area 112. When not in communication with each other, the portion of the ventilation network coupled to the container 110 may be sealed. For example, a removable cover or a flexible gasket may be used.

[0022] The addition of pathogen system 800 may add various capacities to the transport apparatuses 100, 101, 102, and 103 (FIGS. 3 through 6), such as appropriate potentially harmful pathogen activities, which may include detection, identification, alert, containment, and remediation. In the exemplary embodiments, the pathogen system monitors the airflow 324 of outlet duct 124. Clear airflow 324a may be passed on to through the system 100, 101, 102, and 103, and ultimately released to the external environment. Suspect airflow 324b may be contained within the system 100, 101, 102, and 103, for appropriate subsequent action.

[0023] The pathogen system 800 may be configured in a variety of manners. In exemplary apparatus 100, the pathogen system 800 is operatively coupled to the container 110 (FIG. 3). In exemplary apparatus 101, the pathogen system 800 is operatively coupled to the dock 150 (FIG. 4). In exemplary apparatus 102, the pathogen system 800 is operatively coupled to the container 110 through sampler 502, which may include being fixedly coupled to the container 110, attachably coupled once arriving at the dock 15 (FIG. 5), among other potential configurations. In exemplary apparatus 103, the pathogen system 800 may be a stand-alone module, operatively coupleable, as, either or both, warranted and desired by the operator, to the container 110 and the dock 150 (FIG. 6). A “stand-alone module,” as used herein, means a grouping of components of the pathogen system 800 may be packaged into a system that can be individually transported to a use site. Such a “module” may still obtain power and communication connection from a transport apparatus, and still be considered “stand-alone.” Additionally, a particular “stand-alone module” may comprise only parts of the pathogen system 800, where the other components may be separately deliverable to the use site, or operationally integrated into a particular transport apparatus embodiment.

[0024] In the transport apparatus 102, a sampler 502 is operatively coupled to the outlet airflow 324 and the pathogen system 800, through connection 504, to sample the airflow

**324** for potentially harmful pathogens. The exemplary embodiment includes the capacity to suspend the release of suspect outlet airflow **324b**, while permitting the release of clear airflow **324a**.

[0025] In the case of transport apparatus **103**, pathogen system **800** samples the airflow **324** before it enters the heat exchanger **125**, so that only sampled clear airflow **324a**, determined to be safe for release reaches the heat exchanger **125**.

[0026] A processor **160** may be operatively coupled to the container **110** (FIGS. **3** and **5**) or the control unit dock **150** (FIGS. **4** and **6**) to store (e.g., using a memory device) and convey (e.g., through an output device) transport data, such as time data, temperature data, content data, etc. In conveying the transport data, a wireless data transfer system **162** (FIGS. **4** and **6**) or a wired data transfer system **164** to a control panel **165** at the dock **15** (FIGS. **3** and **5**) may be used. In exemplary embodiments of apparatuses **100** and **102**, auxiliary power may be provided to components onboard the insulated container **110** through power hookup **164a**.

[0027] In use, clean laundry is placed in the container **110** at a laundering facility and transported to its destination (e.g., a healthcare facility, etc.). The heat exchanger **125**, climate controller **130**, and dehumidifier **135** may maintain ventilation and acceptable humidity in the interior area **112** for the laundry during transport (FIGS. **3** and **5**) and after being left at a dock (FIGS. **3** through **6**). As such, the laundry may be transported further distances or simply housed in the container **110** for longer amounts of time than possible in prior art systems. Additionally, the pathogen system may provide for remediation of detected pathogens, or prophylactic treatment, en route.

[0028] In many applications, the way laundry is transported is very important. Healthcare facilities, for example, may be required to comply with the Joint Commission on Accreditation of Healthcare Organizations and infectious control guidelines. As should be readily appreciated, transporting or storing clean laundry in a manner that does not protect the laundry from moisture, undesirable temperatures, insects, textile mold, or mildew is not acceptable. Prior art methods and systems often make multiple trips to a single facility during working (i.e., business) hours to maintain the clean nature of the laundry and to collect soiled laundry.

[0029] In most prior art situations, the end user collects laundry during working hours from various workstations. Soiled laundry is placed into linen carts that remain in specified locations throughout the facility. The soiled linen carts are picked up upon arrival of a laundry truck from a processing plant and weighed prior to loading onto the laundry truck. This process can be very inefficient and can lead to delays for both the cleaning staff and the launderers.

[0030] FIG. **2** shows an improved system **200** for laundry transportation and storage that utilizes the laundry transport apparatus **100**. At step **201**, a pathogen system, of which the one shown in FIG. **8** is an example, may pre-screen the environment of the interior area **112** to determine if potentially harmful pathogens are present. The pathogen system **800** may have the capacity to provide notice of a potentially harmful contaminant, permitting an operator to curtail further transport activity in order to address the potential pathogen. System **200** illustrates a curtailed process where pre-screening **201** diverts that system to ongoing pathogen screening **216** and rerouting the cargo back to the laundry facility for further testing and proper remediation. During pre-screening

**201** and further screening **216**, the environment of interior area **112** is contained within container **110**. Embodiments of the pathogen system **800** may be configured to treat particular pathogens within container **110**.

[0031] At step **202**, the container **110** housing clean laundry in the interior area **112** is moved (e.g., by a truck) to a loading dock and left at the loading dock. If the control unit **150** is not used (FIGS. **3** and **5**), the container **110** may simply be left at the loading dock without further action, and the airflow and ventilation described above regarding FIGS. **3** and **5** may occur; if the control unit **150** is used (FIGS. **4** and **6**), the container **110** may be placed in communication with the control unit **150** to allow airflow and ventilation described above regarding FIGS. **4** and **6**. While omitting the control unit **150** may provide a more simple docking process, utilizing a control unit **150** may provide a cost savings, as each individual container **110** does not have to include various elements (as discussed above regarding FIGS. **4** and **6**). Step **202** may occur during business hours or at night; the climate control provided inside the container **110** may allow the laundry to remain in the container **110** overnight without detriment. The processor **160** may be used to track the temperature in the container **110**, humidity in the container **110**, time the laundry was in the container **110**, and/or any other information useful in determining whether the laundry has been compromised while in the container **110**.

[0032] At step **204**, the laundry is then moved into a linen (or “staging”) room, where clean linen carts are configured using the laundry from the container **110** and laundry from a reserve linen area **20** if necessary. If not all laundry from the container **110** is needed for the carts, excess may be placed in the reserve linen area **20**.

[0033] At step **206**, the laundry in the clean linen carts is delivered to a unit for use, and the clean laundry is used at step **208**. After being used, the laundry is placed in a soiled linen hamper at step **210**, and laundry collected in the soiled linen hamper is moved to a linen cart at step **212**. The soiled laundry from the soiled linen cart is collected, weighed, and moved to an empty container **110** at step **214** for transport to a laundering facility.

[0034] At step **216**, the soiled laundry is screened for pathogens. If pathogens are found, the laundry may be treated en route. Otherwise, the laundry facility may be informed of the pathogen status upon arrival. Additionally, depending on the embodiment of the pathogen system, other desired alerts may be provided upon identifying a potential pathogen within the container **110**.

[0035] Referring now to FIG. **8**, an exemplary pathogen system **800** provides the interior chamber **110**, of transport apparatuses **100**, **101**, **102**, and **103**, with the capacity to become a protective environment (PE) for airborne infection isolation (AII), as defined by the Center for Disease Control (CDC). The exemplary system **800** includes an appropriate pump **802**, such as a negative pressure blower pump, to draw the outlet airflow **324** from the interior area **112**. A check valve **804** may be added to ensure airflow **324** that enters the system **800** does not flow back into the interior area **112**. Airflow **324** then enters a flow management system **806** for detecting, and safely segregating clear airflow **324a** from suspect airflow **324b**. The exemplary flow management system **806** may be a double block and bleed system, which employs a first sampling valve **808** to permit the inflow of the airflow **324**, but contain such airflow **324** within the flow management system **806**. Clear sampling valve **810** operates

in conjunction with first valve **808** to route clear airflow **324a** as chosen by the operator. Choices may include recirculation to the interior area **112**, and release to the exterior atmosphere, among others. Suspect sampling valve **812** operates in conjunction with first valve **808** to route suspect airflow **324b** as chosen by the operator. Choices may include routing to an appropriate sequestration apparatus **814**, such as a knock-out tank, and a HEPA filter, among others, and even may include recirculation to the interior space **112**, where the interior space **112** may be used as the appropriate containment device, and even the remediation environment.

**[0036]** An appropriate operator interface **816**, such as a control panel and alerts **816**, may include a variety of controls for the operator to set and adjust choices on managing the pathogen system **800**. The control panel **816** may have a processor that effects the coordination of the first valve **808** with the clear valve **810** and the suspect valve **812** to receive signals from the sensors in the valves and effect the opening and closing of the proper valves to ensure appropriate controlled sequestration of clear airflow **324a** from suspect airflow **324b**. Appropriate controls and alerts may also include system and line pressure indicators **818**, pathogen concentration indicators **820**, and alarm state indicators **822**.

**[0037]** The foregoing disclosure and description of the invention is illustrative and explanatory thereof. The present invention should only be limited by the following claims and their legal equivalents. The inventor trusts and relies on this legal principle, in order to avoid being unnecessarily repetitive and verbose. Various changes in the details of the illustrated construction may be made within the scope of the appended claims by one having ordinary skill in the art without departing from the spirit of the invention and scope of the claims. Such changes expressly considered are other combinations, permutations, and arrangements of the elements contained within the apparatuses **100**, **101**, **102**, and **103**.

I claim:

1. A laundry transport apparatus, comprising:
  - a container defining an interior area and having a door for accessing said interior area, said door being movable between closed and open configurations to selectively allow access to said interior area, said interior area having a length;
  - a ventilation network to pass air to and from said interior area, said ventilation network including an intake duct for channeling air to said interior area and an outlet duct for channeling air from said interior area, said intake and outlet duct in a thermal transfer configuration for at least a fifth of the length of the interior area, said interior area airtight apart from said ventilation network when said door is in said closed configuration;
  - at least one fan configured to cause air to pass through either or both said intake duct and said outlet duct.
2. The laundry transport apparatus of claim **1**, further comprising:
  - a climate controller for selectively heating and cooling air passing through said intake duct after said air passes through said thermal transfer configuration to cause said air passing through said intake duct to approximate a temperature of air in said interior area independent of heat exchange due to said ventilation network.
3. The laundry transport apparatus of claim **2**, further comprising:
  - a dehumidifier to selectively dehumidify air passing through said intake duct.

4. The laundry transport apparatus of claim **3**, further comprising:
  - said thermal transfer configuration, said climate controller, and said dehumidifier operatively coupled to said container.
5. The laundry transport apparatus of claim **1**, further comprising:
  - said container has a cart area configured to accommodate a plurality of laundry carts in said interior area.
6. The laundry transport apparatus of claim of **6**, wherein:
  - said thermal transfer configuration coupled to said container above said cart area, and a branch from at least one of said intake duct and outlet duct extend downwardly toward said cart area.
7. The laundry transport apparatus of claim **1**, further comprising a processor operatively coupled to said container to store and convey transport data.
8. The laundry transport apparatus of claim **8**, wherein transport data includes at least one of: time data, duration data, and temperature data.
9. The laundry transport apparatus of claim **1**, further comprising:
  - a pathogen system;
  - said pathogen system having a flow management system, for directing an airflow, operatively coupled to a pathogen control processor;
  - said pathogen control processor capable of controlling the flow management system to detect and isolate a portion of the airflow determined to be contaminated with potential pathogens, and selectively routing the contaminated portion of the airflow for pathogen isolation.
10. The laundry transport apparatus of claim **10**, wherein the pathogen system has the capacity to perform pathogen remediation of the contaminated portion of the airflow.
11. The laundry transport apparatus of claim **10**, wherein the pathogen system is a stand-alone module, operatively coupleable to the ventilation network.
12. A laundry transport apparatus, comprising:
  - a container configured for roadway transport having opposed front and rear ends, said container defining an opening and an interior area, and an interior area length from the front end to the rear end, said container includes a door at said opening for selectively accessing said interior area, said door being movable between a closed configuration preventing access to said interior area and an open configurations giving access to said interior area, said interior area having a cart area capable to hold a plurality of laundry carts configured to hold laundry;
  - a ventilation network situated in said interior area and configured to pass air to and from said interior area, said ventilation network including an intake duct operatively coupled to a top wall of said trailer and extending longitudinally between said front and rear ends, said intake duct configured to channel air to said interior area, and an outlet duct configured to channel air away from said interior area, said intake duct and said outlet duct in a thermal transfer configuration for at least a fifth of said interior area length, said interior area is airtight apart from said ventilation network when said door is at said closed configuration; and
  - at least one fan configured to cause air to pass through either or both said intake duct and said outlet duct.
13. The laundry transport apparatus of claim **12**, further comprising:

- said thermal transfer configuration coupled to said container above said cart area, and a branch from at least one of said intake duct and outlet duct extend downwardly toward said cart area.
- a climate controller for selectively heating and cooling air passing through said intake duct after said air is influenced by air passing through said outlet duct to cause said air passing through said intake duct to approximate a temperature of air in said interior area separate from said ventilation network; and
- a dehumidifier to selectively dehumidify air passing through said intake duct.
- 14.** The laundry transport apparatus of claim **12**, further comprising:
- a pathogen system;
  - said pathogen system having a flow management system, for directing an airflow, operatively coupled to a pathogen control processor;
  - said pathogen control processor capable of controlling the flow management system to detect and isolate a portion of the airflow determined to be contaminated with potential pathogens, and selectively routing the contaminated portion of the airflow for isolation.
- 15.** The laundry transport apparatus of claim **14**, wherein the pathogen system has the capacity to perform pathogen remediation of the contaminated portion of the airflow.
- 16.** The laundry transport apparatus of claim **13**, wherein the pathogen system is a stand-alone module, operatively coupleable to the ventilation network.
- 17.** A laundry transport apparatus, comprising:
- a container having a roadway trailer component and having opposed front and rear ends, said container defining an opening and an interior area, and an interior area length from the front end to the rear end, said container includes a door at said opening for selectively accessing said interior area, said door being movable between a closed configuration preventing access to said interior area and an open configurations giving access to said interior area, said interior area having a cart area capable to hold a plurality of laundry carts configured to hold laundry;
  - a ventilation network situated in said interior area and configured to pass air to and from said interior area, said ventilation network including an intake duct operatively coupled to a top wall of said trailer and extending longitudinally between said front and rear ends, said intake duct configured to channel air to said interior area, and an outlet duct configured to channel air away from said interior area, said intake duct and said outlet duct in a thermal transfer configuration for at least a fifth of said interior area length, said interior area is airtight apart from said ventilation network when said door is at said closed configuration; and
  - at least one fan configured to cause air to pass through either or both said intake duct and said outlet duct;
- said thermal transfer configuration coupled to said container above said cart area, and a branch from at least one of said intake duct and outlet duct extend downwardly toward said cart area;
- a climate controller for selectively heating and cooling air passing through said intake duct after said air is influenced by air passing through said outlet duct to cause said air passing through said intake duct to approximate a temperature of air in said interior area separate from said ventilation network;
  - a dehumidifier to selectively dehumidify air passing through said intake duct; and
  - a pathogen system, said pathogen system having a flow management system, for directing an airflow, operatively coupled to a pathogen control processor, and said pathogen control processor capable of controlling the flow management system to detect and isolate a portion of the airflow determined to be contaminated with potential pathogens, and selectively routing the contaminated portion of the airflow for isolation, said pathogen system has the capacity to perform pathogen remediation of the contaminated portion of the airflow.
- 18.** The laundry transport apparatus of claim **17**, wherein the pathogen system is a stand-alone module, operatively coupleable to the ventilation network.

\* \* \* \* \*