



(19) **United States**

(12) **Patent Application Publication**
Johnson et al.

(10) **Pub. No.: US 2017/0266802 A1**
(43) **Pub. Date: Sep. 21, 2017**

(54) **BIAXIAL FOLDOUT TOOL WITH
MULTIPLE TOOLS ON A SIDE AND A
ROTATIONAL STOP**

Publication Classification

(71) Applicant: **WAGIC, INC.**, San Jose, CA (US)

(51) **Int. Cl.**
B25F 1/04 (2006.01)
B25G 1/08 (2006.01)
B25B 15/00 (2006.01)
B25G 1/06 (2006.01)

(52) **U.S. Cl.**
 CPC *B25F 1/04* (2013.01); *B25B 15/008*
 (2013.01); *B25G 1/066* (2013.01); *B25G*
1/085 (2013.01); *B25B 15/00* (2013.01)

(72) Inventors: **Ronald L. Johnson**, San Jose, CA (US); **Robert J. Gallegos**, Fremont, CA (US); **Steven Simas Escobar**, San Jose, CA (US); **Idriss Mansouri-Chafik Ruiz**, Santa Clara, CA (US); **Yugen Patrick Lockhart**, Palo Alto, CA (US)

(21) Appl. No.: **15/611,678**

(57) **ABSTRACT**

(22) Filed: **Jun. 1, 2017**

A biaxial foldout tool includes a body with opposing ends and one or more sets of tool drivers. The opposing ends are rotated 90° from each other. A first set of tool drivers is positioned on/near a first end and rotates about a first hinge; a second set of tool drivers is positioned on/near a second end and rotates about a second hinge. A first portion of the first set opens in a direction counter to an open direction of a second portion of the first set of tool drivers. A first portion of the second set opens in a direction counter to an open direction of a second portion of the second set of tool drivers. When tool drivers are in an open position, internal stops prevent the tool drivers from opening past a predetermined angle. The tool drivers are contained within channels of the body when in a closed position.

Related U.S. Application Data

(63) Continuation of application No. 14/491,891, filed on Sep. 19, 2014, now Pat. No. 9,701,005, which is a continuation of application No. 13/908,703, filed on Jun. 3, 2013, now Pat. No. 8,875,601, which is a continuation of application No. 12/567,606, filed on Sep. 25, 2009, now Pat. No. 8,468,916, which is a continuation-in-part of application No. 12/009,461, filed on Jan. 17, 2008, now Pat. No. 8,925,429.

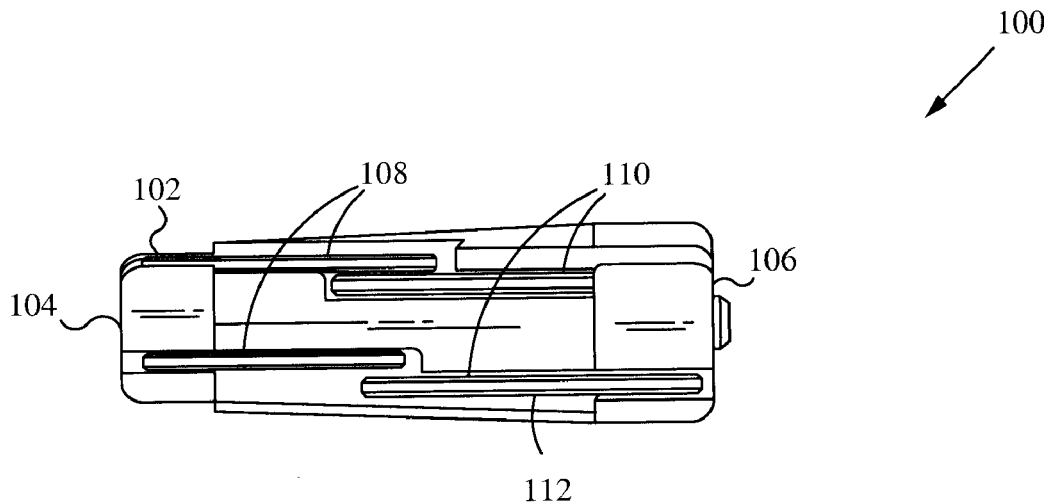

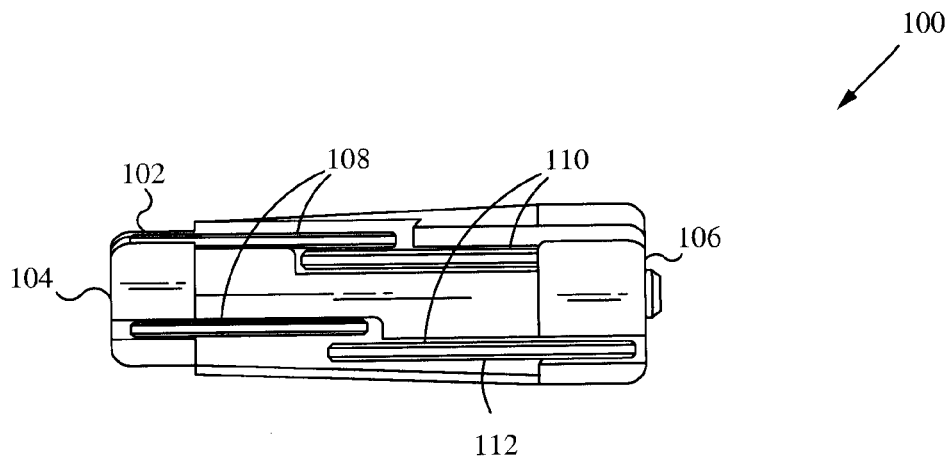

Fig. 1

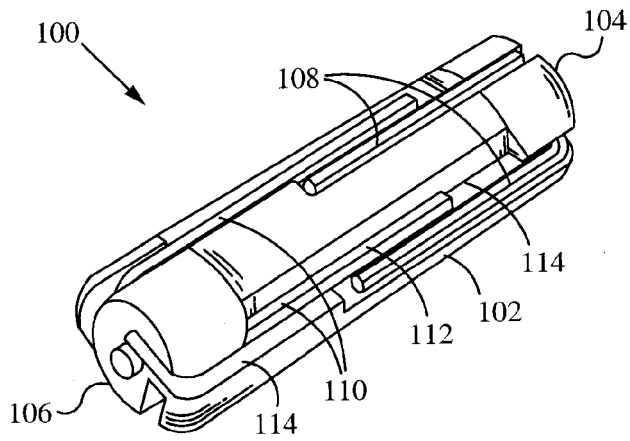

Fig. 2

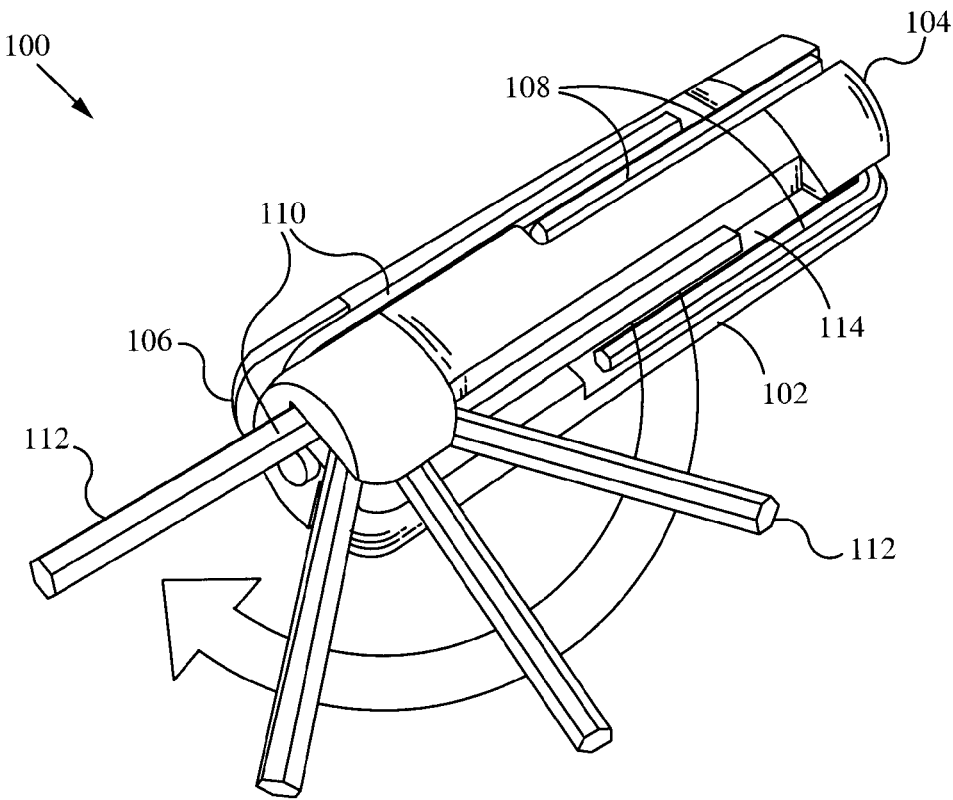

Fig. 3

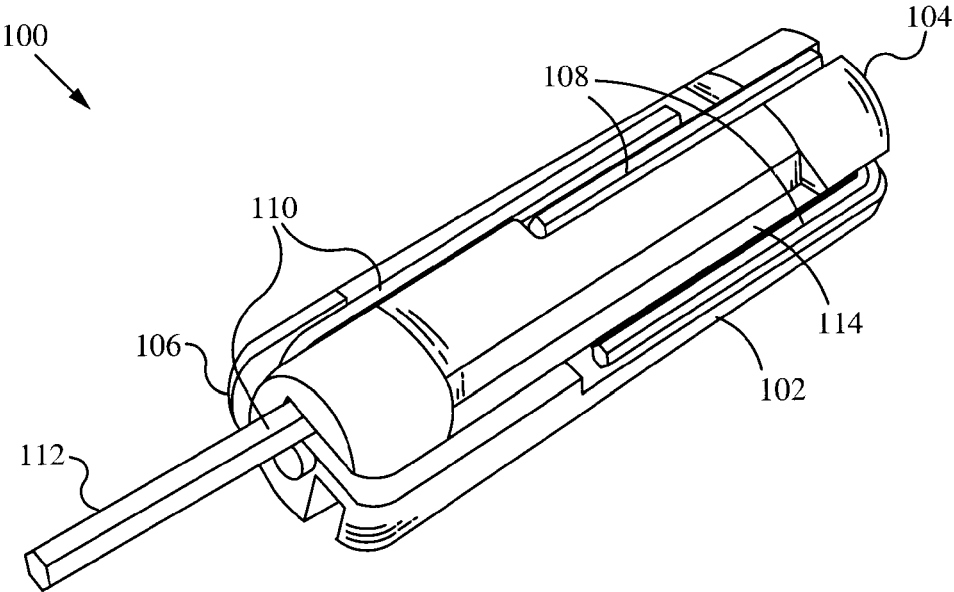

Fig. 4

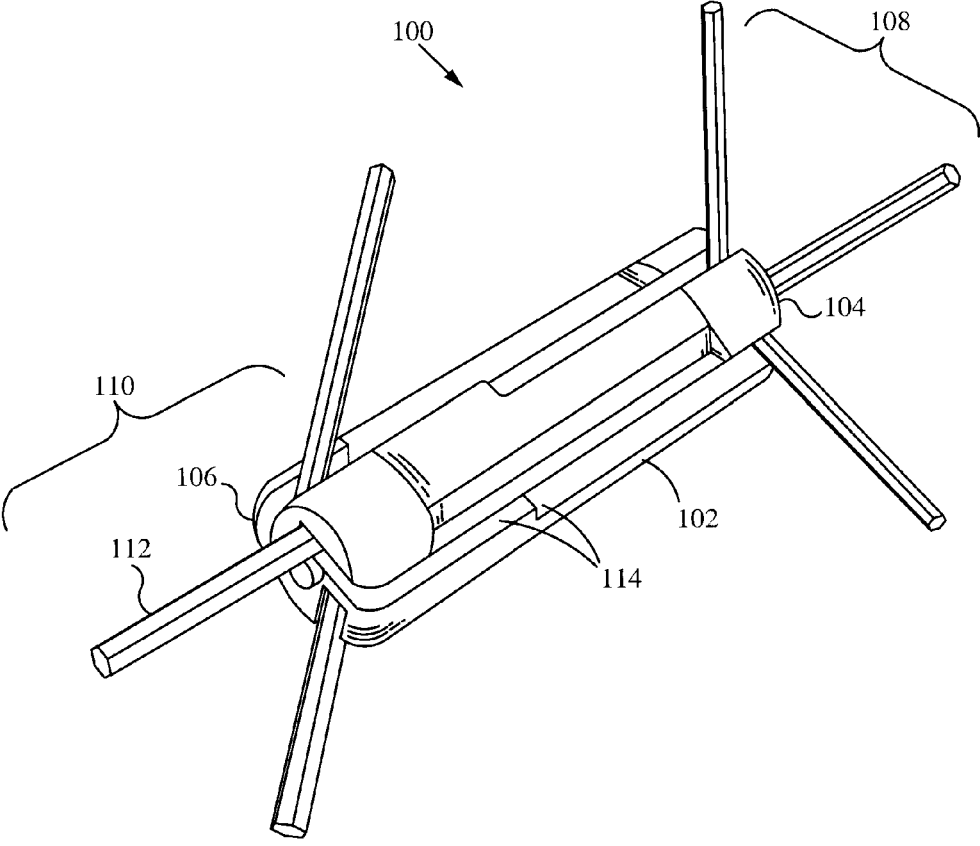

Fig. 5

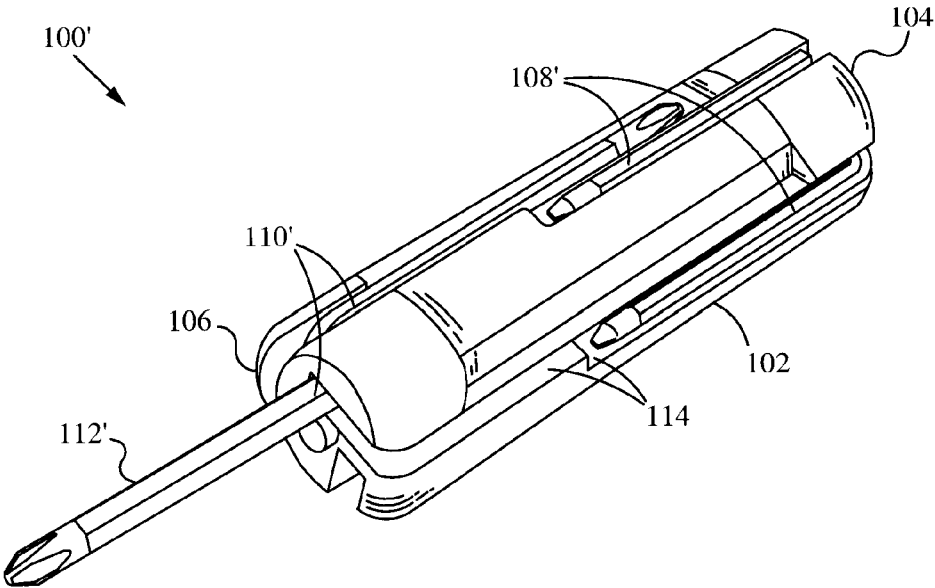

Fig. 6A

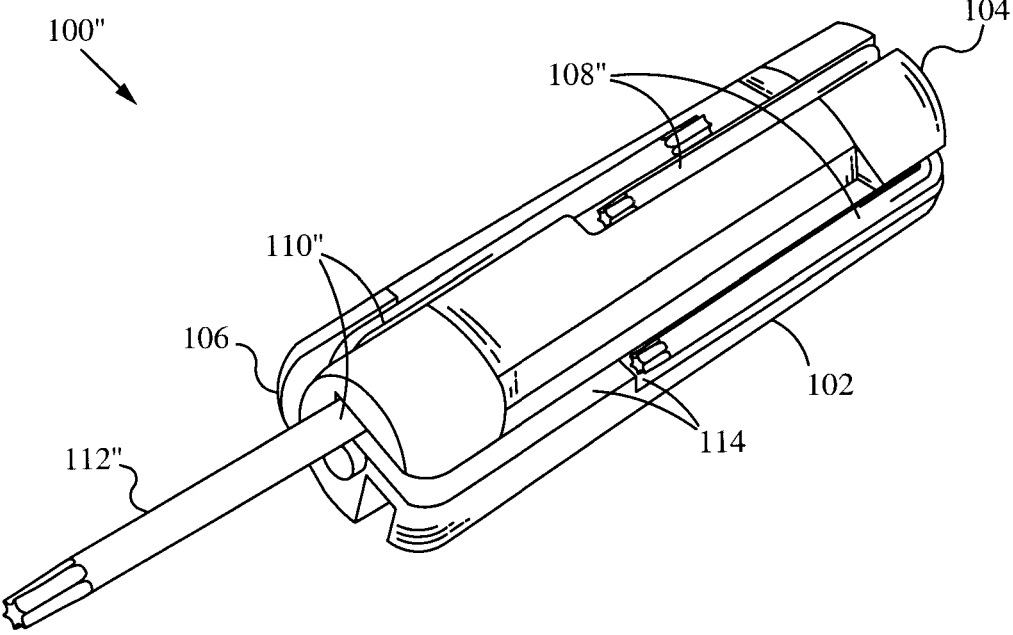

Fig. 6B

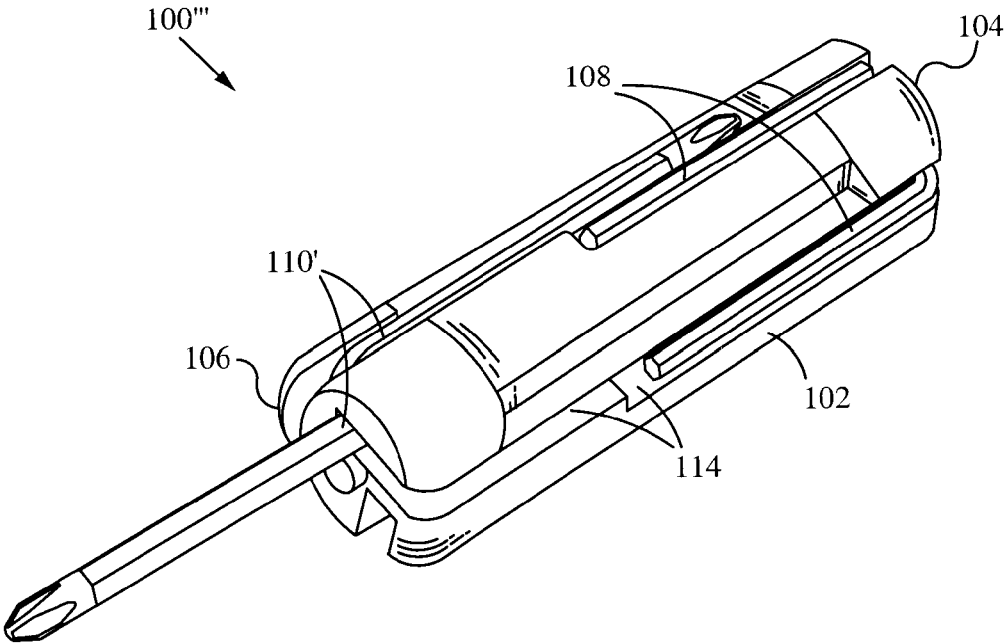

Fig. 6C

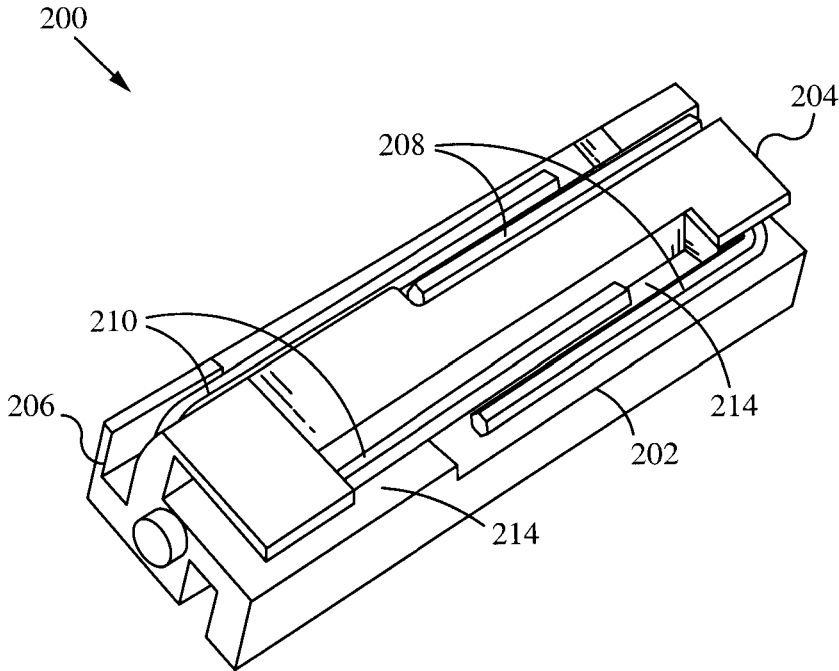

Fig. 7

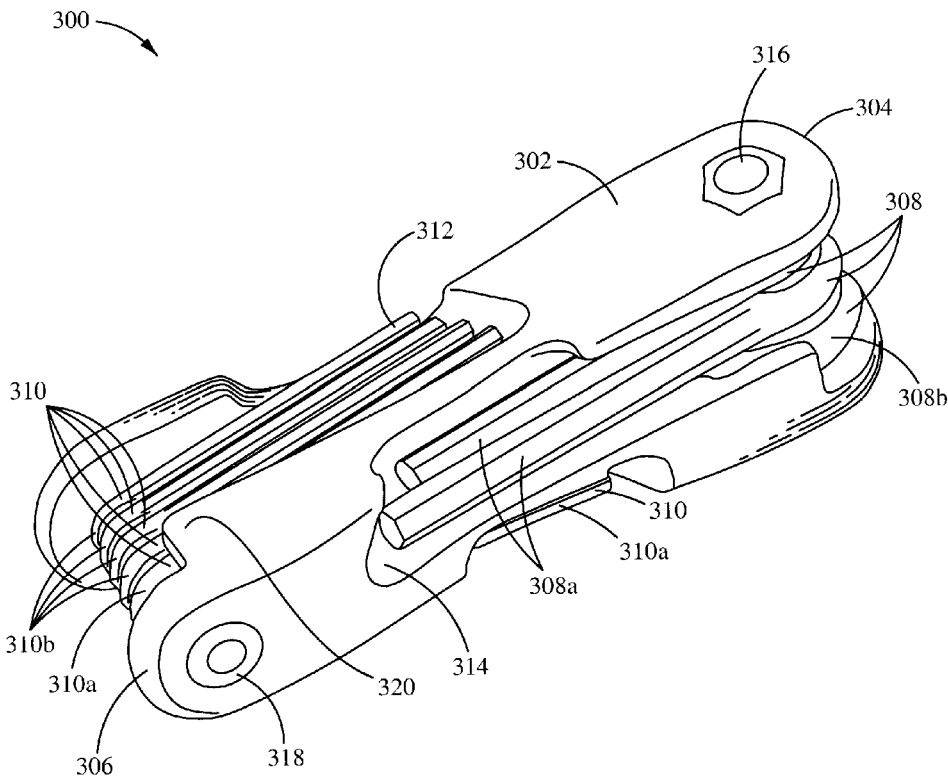

Fig. 8A

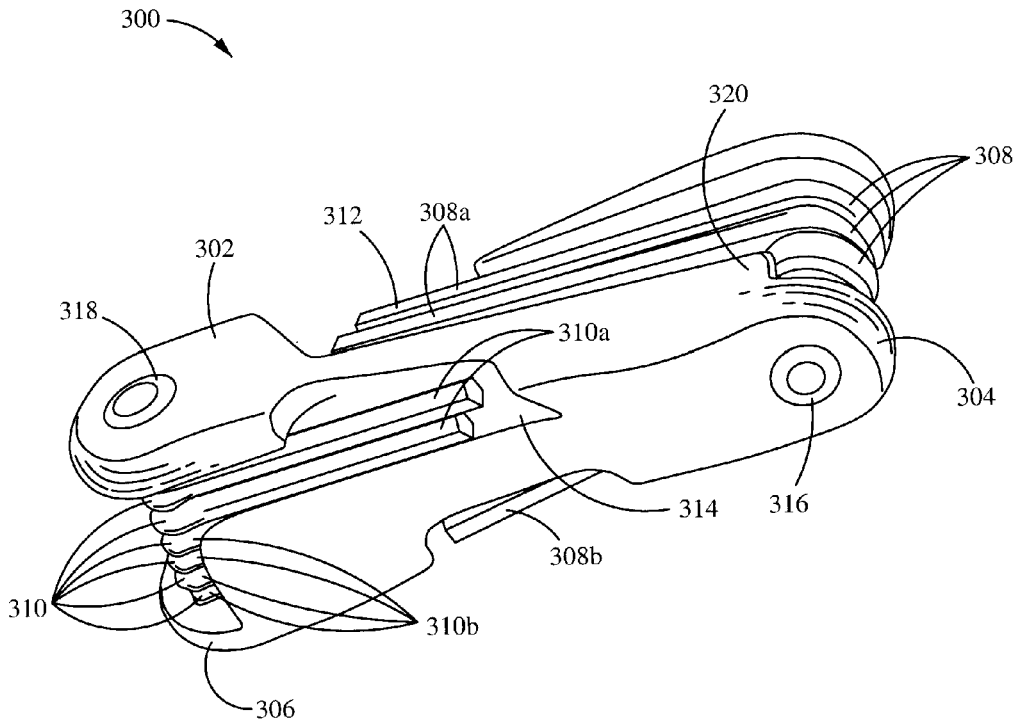

Fig. 8B

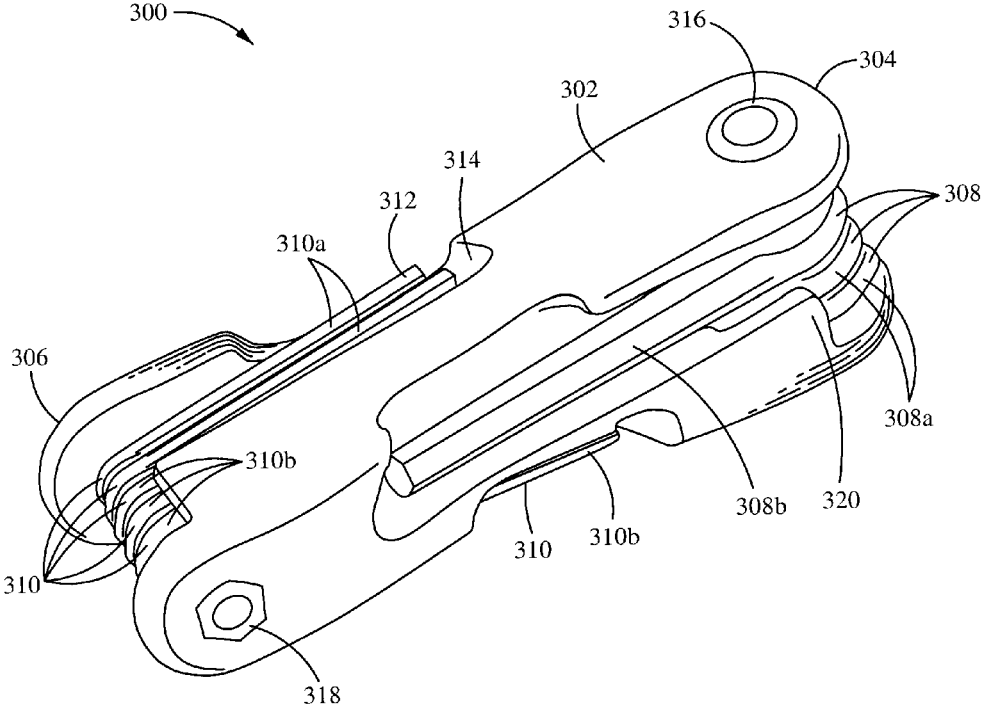

Fig. 8C

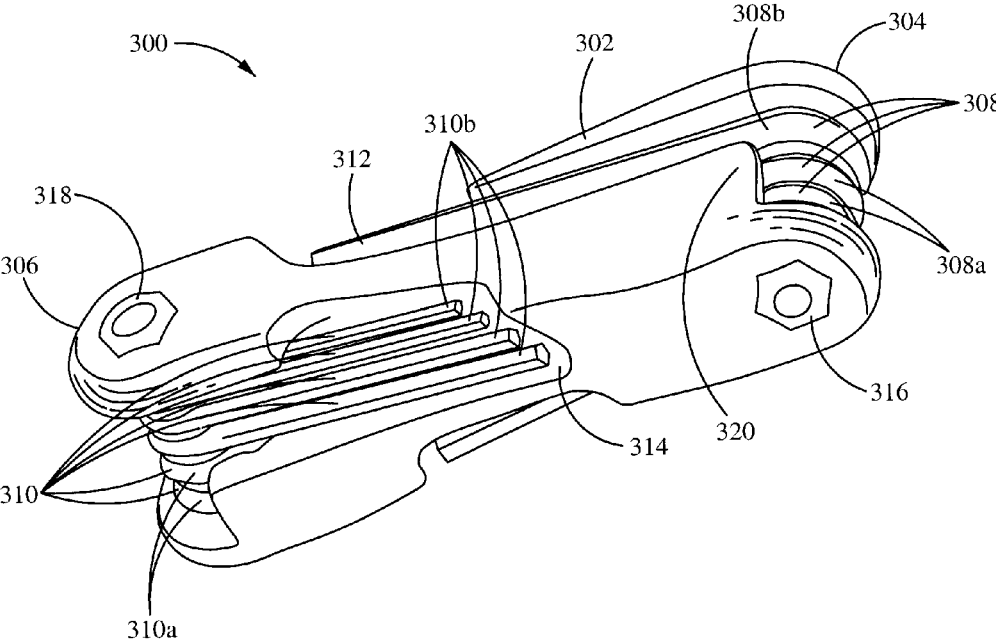

Fig. 8D

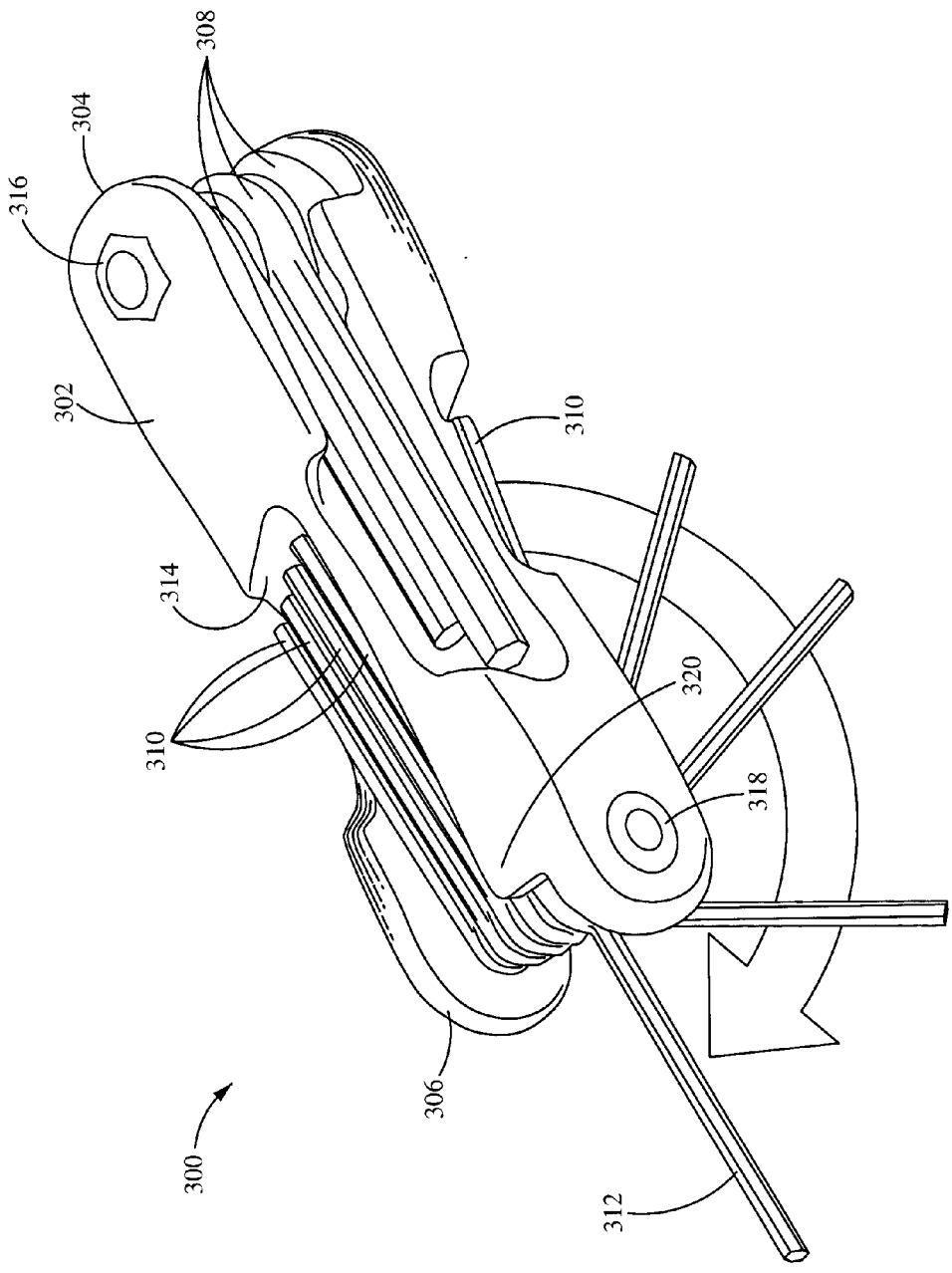

Fig. 9

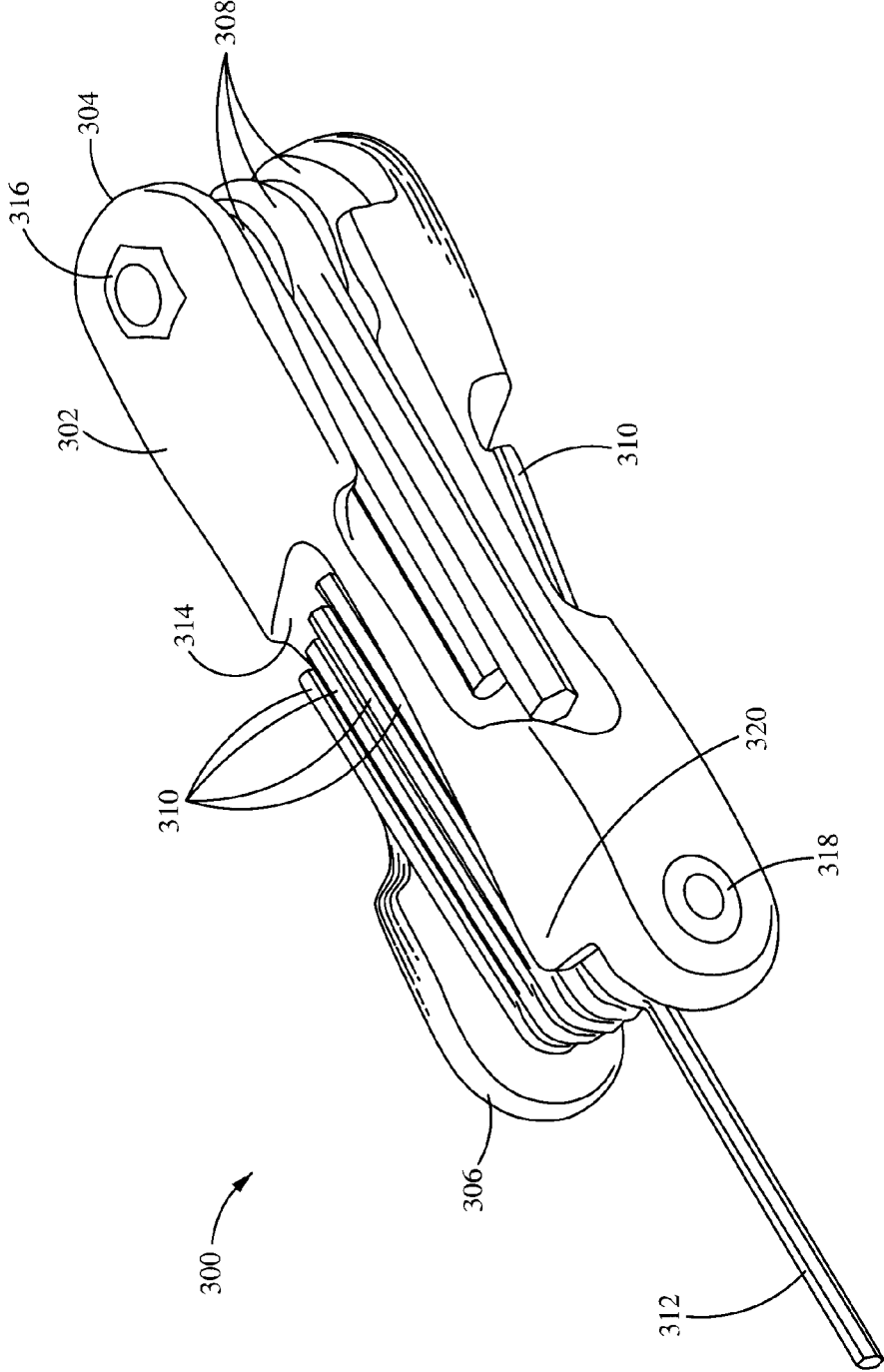

Fig. 10A

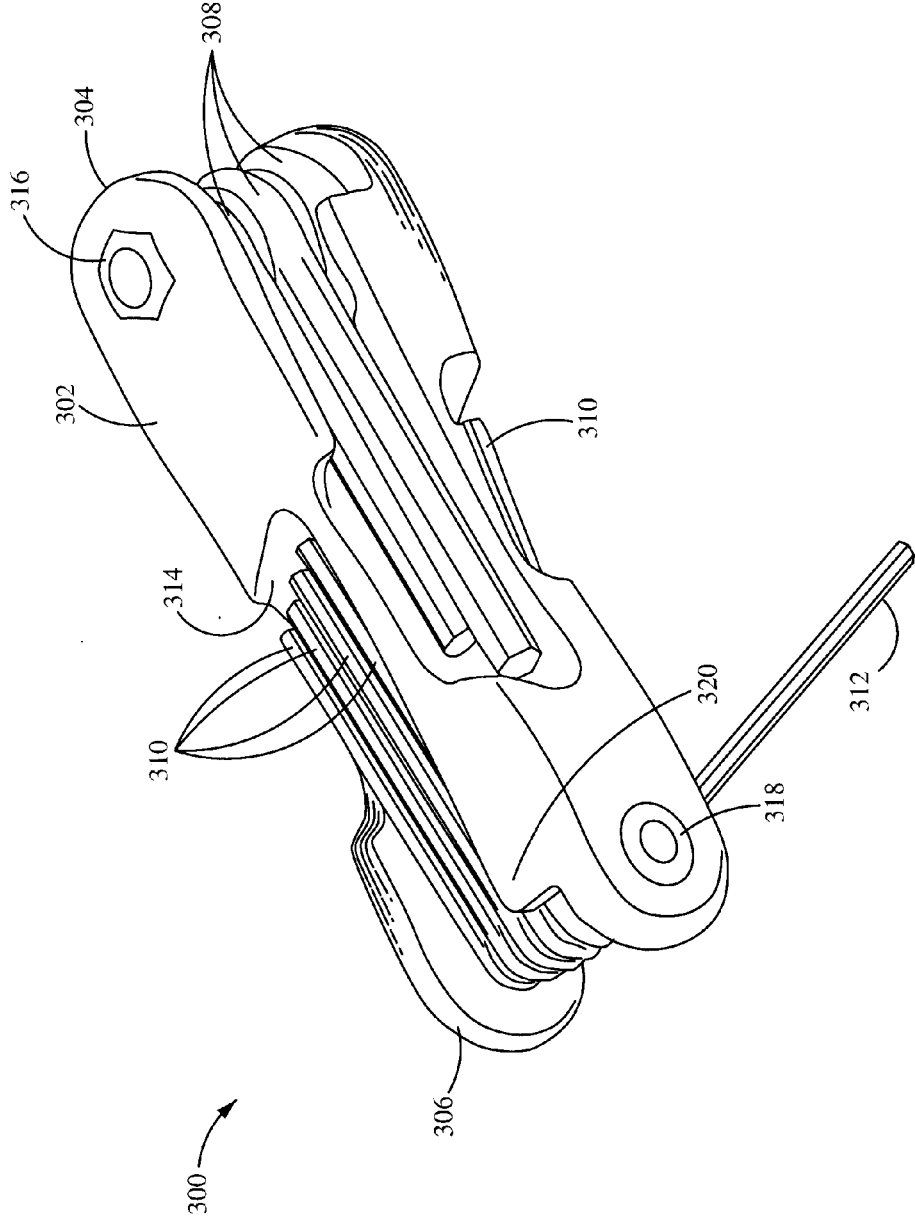

Fig. 10B

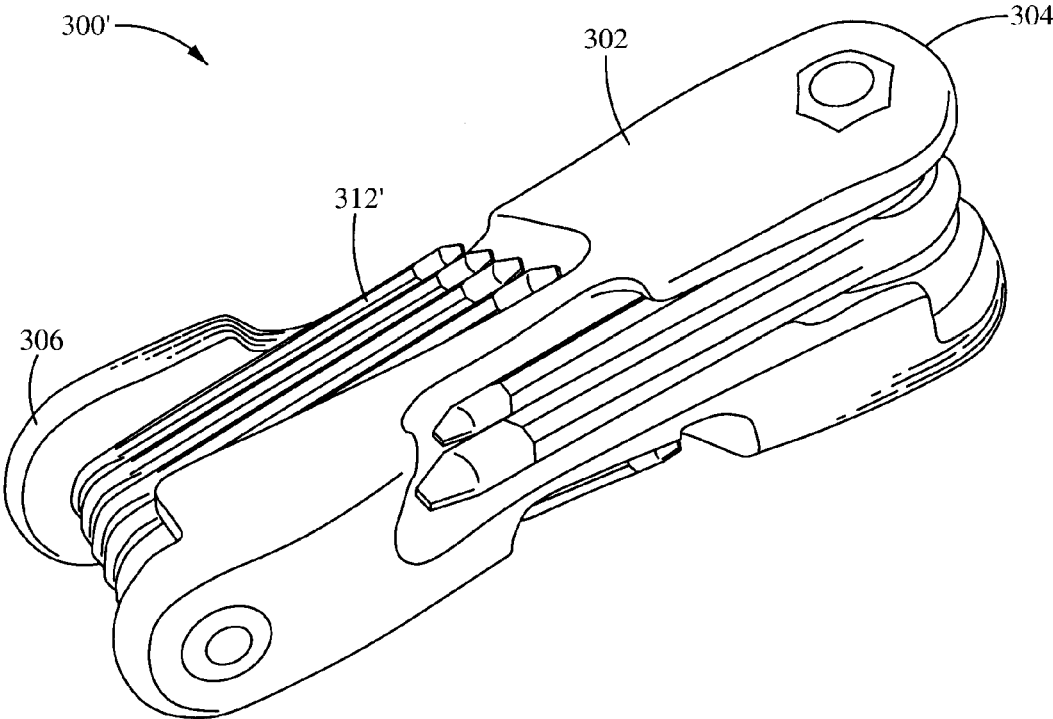

Fig. 11A

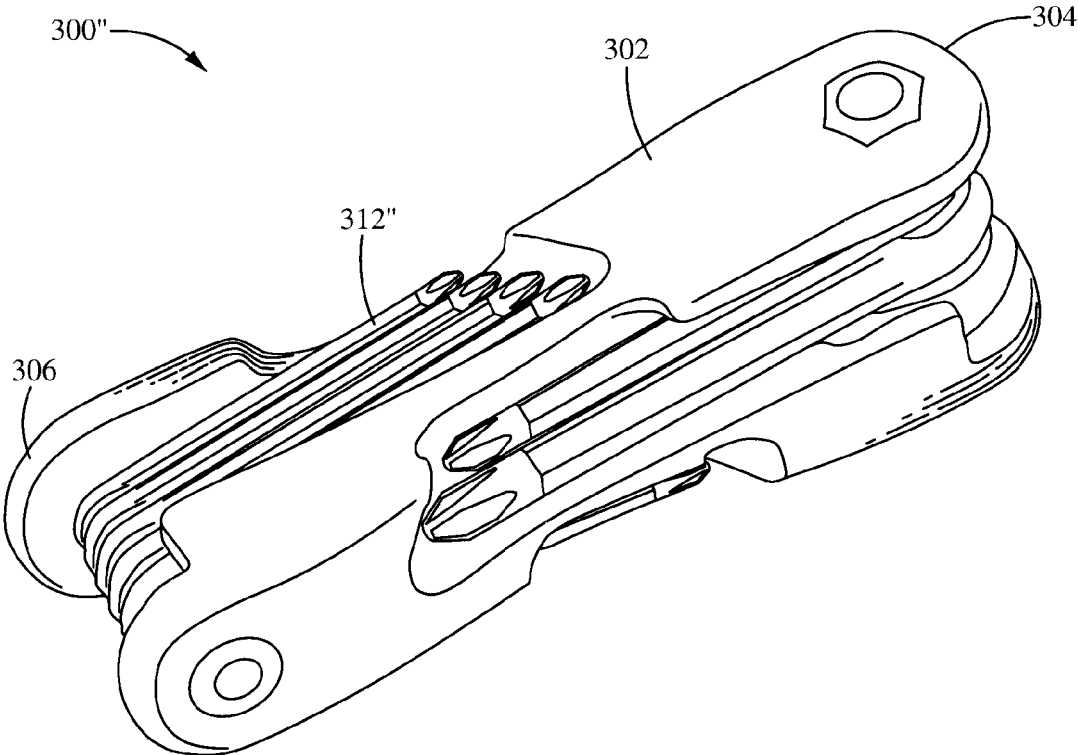

Fig. 11B

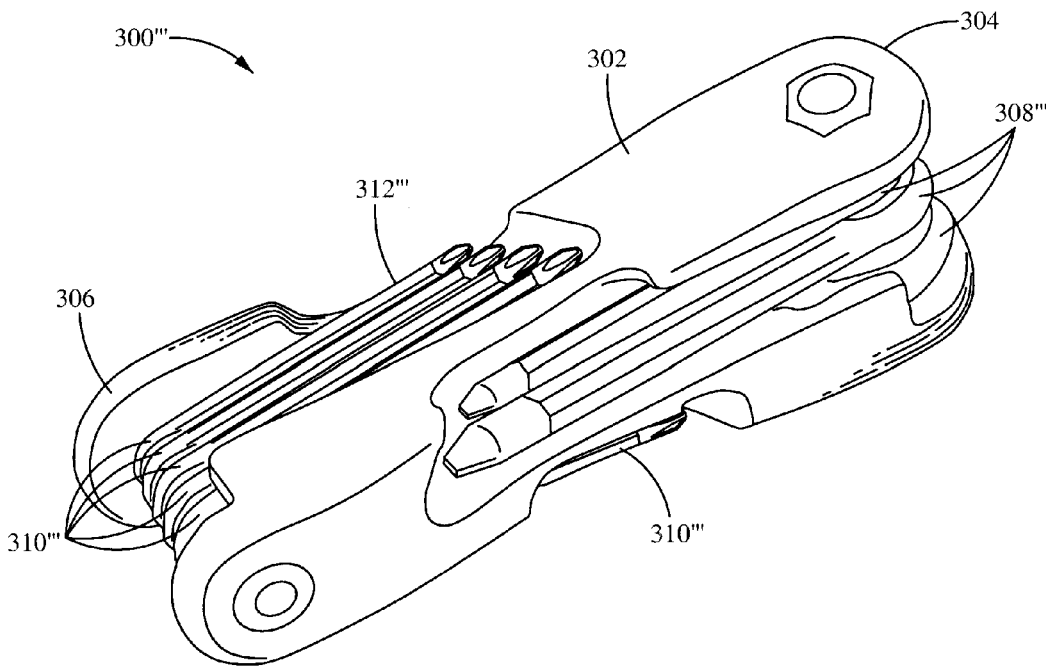

Fig. 11C

BIAXIAL FOLDOUT TOOL WITH MULTIPLE TOOLS ON A SIDE AND A ROTATIONAL STOP

RELATED APPLICATIONS

[0001] This patent application is a continuation-in-part of the co-pending U.S. patent application Ser. No. 12/009,461, filed Jan. 17, 2008, entitled "RADIAL FOLDOUT TOOL," which is hereby incorporated by reference.

FIELD OF THE INVENTION

[0002] The present invention relates to the field of hand held tools. More specifically, the present invention relates to the field of hexagonal wrenches and related tools and safety, comfort, and convenience of accessories and tools.

BACKGROUND OF THE INVENTION

[0003] Hexagonal wrenches or tool drivers, also referred to as allen wrenches or L-wrenches, have a hexagonal L-shaped body, including a long leg member and a short leg member. The end of either leg member is able to be inserted into a head of a screw or tool designed to accept a hexagonal wrench. Once inserted, rotational pressure is applied to the hexagonal wrench in order to tighten or loosen the screw. The leg members of the hexagonal wrench are designed to be of different lengths in order to allow a user flexibility when using the wrench in different environments and situations. For example, in a narrow, confined environment, the long leg of the hexagonal wrench is inserted into the head of the screw and the user will apply rotational pressure to the short leg. Or, if the environment is not so confined, the user is able to insert the short leg of the hexagonal wrench into the head of the screw and apply rotational pressure to the long leg.

[0004] Hexagonal wrenches are manufactured and distributed in multiple English (e.g., standard) and metric sizes in order to facilitate their use with screw heads of multiple sizes. Such wrenches are usually sold in a set which includes wrenches of multiple sizes but are also distributed individually.

[0005] When using a hexagonal wrench, a user will insert an end of the hexagonal wrench into the head of a workpiece such as a screw, and will then exert rotational pressure on the opposite end of the wrench in order to tighten or loosen the screw. Because of the size and dimensions of the hexagonal wrench it is particularly difficult to exert a great amount of rotational pressure on the hexagonal wrench when the long leg of the hexagonal wrench is inserted into the head of the screw. Because the hexagonal wrench is typically turned with the user's fingers, the user is able to also experience scrapes and cuts from the use of hexagonal wrenches in this manner. Ingenuitive users have also used other tools, including vice grips, pliers and the like, to turn hexagonal wrenches. However, this method is disadvantageous because such tools are able to lose their hold on the hexagonal wrench when rotational pressure is applied or are able to even bend or otherwise disfigure the hexagonal wrench.

SUMMARY OF THE INVENTION

[0006] A radial foldout tool includes a body with opposing ends and one or more sets of tool drivers. A first set of tool drivers are positioned on/near a first end and a second set of tool drivers are positioned on/near a second end. The tool

drivers are contained within channels of the body when in a closed position. The tool drivers are also contained in a plurality of planes. The tool drivers open by rotating/moving in a direction at least perpendicular to a neighboring tool driver. When they are in an open position, each of the tool drivers are in/near the center of the end of the body. By being positioned in/near the center of the end, the radial foldout tool is able to be gripped and turned in a fashion similar to a standard screwdriver.

[0007] In one aspect, a device comprises a body having a center, a first end and a second end, wherein the first end and the second end are positioned on opposite ends of the body and a first set of tool drivers positioned within the body in a plurality of planes, wherein each tool driver of the first set of tool drivers is configured to be positioned generally in the center out of the first end in an open position. The device further comprises a second set of tool drivers positioned within the body in the plurality of planes, wherein the second set of tool drivers are configured to be positioned out of the second end. The first set of tool drivers and the second set of tool drivers are positioned within the body in a closed position. Each tool driver of the second set of tool drivers is positioned out of the second end in an open position. Each tool driver of the second set of tool drivers is positioned generally in the center of the second end in an open position. In some embodiments, a first tool driver of the first set of tool drivers is in the same plane as a second tool driver of the second set of tool drivers. The body includes a set of channels for the first set of tool drivers and the second set of tool drivers to be positioned in the closed position. In some embodiments, each tool driver of the first set of tool drivers is positioned at least 90° around the circumference of the first end away from a neighboring tool driver and each tool driver of the second set of tool drivers is positioned at least 90° around the circumference of the second end away from a neighboring tool driver. The body is generally cylindrical. In some embodiments, the first set of tool drivers and the second set of tool drivers are selected from the group consisting of hexagonal wrenches, screwdrivers, socket wrenches and star-shaped drivers. In some embodiments, the first set of tool drivers are hexagonal wrenches and the second set of tool drivers are screwdrivers. The device further comprises a stop within the body for preventing each of the first set of tool drivers from opening further. In some embodiments, each of the first set of tool drivers do not open further than 180°.

[0008] In another aspect, a device comprises a body having a center, the body including a plurality of faces, a first end and a second end, wherein the first end and the second end are positioned on opposite ends of the body, a first set of tool drivers, each tool driver of the first set of tool drivers positioned within the body on a face of the plurality of faces, wherein the first set of tool drivers are configured to be positioned generally in the center out of the first end in an open position and a second set of tool drivers, each tool driver of the second set of tool drivers positioned on a face of the plurality of faces within the body, wherein the first set of tool drivers are configured to be positioned generally in the center out of the second end in an open position. The first set of tool drivers and the second set of tool drivers are positioned within the body in a closed position. In some embodiments, a first tool driver of the first set of tool drivers is in the same plane as a second tool driver of the second set of tool drivers. The body includes a set of channels for the

first set of tool drivers and the second set of tool drivers to be positioned in the closed position. Each tool driver of the first set of tool drivers and the second set of tool drivers is positioned in the open position by rotation in a substantially perpendicular direction away from the face. The body is generally cylindrical. In some embodiments, the first set of tool drivers and the second set of tool drivers are selected from the group consisting of hexagonal wrenches, screwdrivers, socket wrenches and star-shaped drivers. In some embodiments, the first set of tool drivers are hexagonal wrenches and the second set of tool drivers are screwdrivers. The device further comprises a stop within the body for preventing each of the first set of tool drivers and the second set of tool drivers from opening further.

[0009] In yet another aspect, a generally cylindrical tool handle having a body with a center, a first end and a second end and a generally cylindrical surface, the handle including a plurality of tool drivers each of a differing size in a plurality of planes, wherein each of the plurality of tool drivers includes an elongated rod coupled with the tool handle having a bend through a predetermined angle and including a proximal end for engaging an object, and a mounting end between the bend and a distal end, further wherein each tool driver of the set of tool drivers is positioned generally in the center of one of the first end and the second end in an open position. The set of tool drivers are positioned within the body in a closed position. In some embodiments, each tool driver of the set of tool drivers is positioned at least 90° around the circumference of one of the first end and the second end away from a neighboring tool driver. The tool handle further comprises a stop within the body for preventing each tool driver of the set of tool drivers from opening further.

[0010] In yet another aspect, a device comprises a body. The body includes a first face opposite a third face, a second face opposite a fourth face, and a first end opposite a second end, wherein the first end and the second end are rotated 90° from each other. A portion of each face is typically represented on each end. The device further comprises a first hinge located at the first end, wherein the first hinge couples together the second face and the fourth face, and a first set of tool drivers positioned within the body, wherein each tool driver of the first set of tool drivers is configured to rotate about the first hinge. A first portion of the first set of tool drivers is positioned within the first face and a second portion of the first set of tool drivers is positioned within the third face of the body in a closed position. Tool drivers of the first portion of the first set open in a direction counter to an open direction of tool drivers of the second portion of the first set. Tool drivers of the first portion of the first set are positioned within the first face according to size, and tool drivers of the second portion of the first set are positioned within the third face according to size. The device further comprises a first internal stop on the first face configured to prevent tool drivers of the second portion of the first set from opening past 180°, and a second internal stop on the third face configured to prevent tool drivers of the first portion of the first set from opening past 180°. In some embodiments, the device further comprises a second hinge located at the second end, wherein the second hinge couples together the first face and the third face, and a second set of tool drivers positioned within the body, wherein each tool driver of the second set of tool drivers is configured to rotate about the second hinge. A first portion of the second set of tool drivers

is positioned within the second face and a second portion of the second set of tool drivers is positioned within the fourth face of the body in a closed position. Tool drivers of the first portion of the second set open in a direction counter to an open direction of tool drivers of the second portion of the second set. Tool drivers of the first portion of the second set are positioned within the second face according to size, and tool drivers of the second portion of the second set are positioned within the fourth face according to size. The device further comprises a first internal stop on the second face configured to prevent tool drivers of the second portion of the second set from opening past 180°, and a second internal stop on the fourth face configured to prevent tool drivers of the first portion of the second set from opening past 180°.

[0011] In yet another aspect, a tool comprises a body including a plurality of sides, a first end and a second end, wherein the first end and the second end are twisted 90° from each other, a plurality of hinges including a first hinge and a second hinge, wherein the first hinge couples together a second side and a fourth side, wherein the second hinge couples together a first side with a third side, a first set of tool drivers configured to rotate about the first hinge, and a second set of tool drivers configured to rotate about the second hinge. Tool drivers of the first set of tool drivers and the second set of tool drivers fit securely within channels of the body. A first portion of the first set of tool drivers is positioned within the first side of the body and a second portion of the first set of tool drivers is positioned within the third face of the body in a closed position. Tool drivers of the first portion of the first set are arranged according to size, and tool drivers of the second portion of the first set are arranged according to size. The tool further comprises a first stop integral to the first face configured to prevent tool drivers of the second portion of the first set from opening past 180°, and a second stop integral to the third face configured to prevent tool drivers of the first portion of the first set from opening past 180°. A first portion of the second set of tool drivers is positioned within the second face and a second portion of the second set of tool drivers is positioned within the fourth face of the body in a closed position. Tool drivers of the first portion of the second set are arranged according to size, and tool drivers of the second portion of the second set are arranged according to size. The tool further comprises a first stop integral to the second face configured to prevent tool drivers of the second portion of the second set from opening past 180°, and a second stop integral to the fourth face configured to prevent tool drivers of the first portion of the second set from opening past 180°.

[0012] In yet another aspect, an apparatus comprises a body including a first end and a second end, wherein the first end has a first hinge and the second end has a second hinge, further wherein the first end and the second end are rotated 90° from each other, a first set of tool drivers coupled to and rotates about the first hinge, wherein a first subset of the first set of tool drivers is positioned within a first side of the body in order of size and a second subset of the first set of tool drivers is positioned within a third side of the body in order of size, further wherein the first side and third side are opposite sides of the body, a second set of tool drivers coupled to and rotates about the second hinge, wherein a first subset of the second set of tool drivers is positioned within a second side of the body in order of size and a second subset of the second set of tool drivers is positioned within a fourth

side of the body in order of size, further wherein the second side and the fourth side are opposite sides of the body, and a plurality of internal stops. The plurality of internal stops includes a first internal stop at a distal end of the second hinge on the first side, the first internal stop configured to prevent tool drivers of the second subset of the first set of tool drivers from opening past 180°, a second internal stop at a distal end of the first hinge on the second side, the second internal stop configured to prevent tool drivers of the second subset of the second set of tool drivers from opening past 180°, a third internal stop at a distal end of the second hinge on the third side, the third internal stop configured to prevent tool drivers of the first subset of the first set of tool drivers from opening past 180°, and a fourth internal stop at a distal end of the first hinge on the fourth side, the fourth internal stop configured to prevent tool drivers of the first subset of the second set of tool drivers from opening past 180°.

[0013] In yet another aspect, a tool handle comprising a body with a generally cylindrical surface, the body comprises four sides, wherein each side has a plurality of tool drivers coupled to a first end via a hinge, a recessed area at an opposite end to receive an end of another hinge, and an internal stop near the first end configured to prevent a portion of the plurality of the tool drivers from opening past a predetermined angle. In some embodiments, the predetermined angle is 180°. In other embodiments, the predetermined angle is 90°.

BRIEF DESCRIPTION OF THE DRAWINGS

[0014] FIG. 1 illustrates an isometric view of a radial foldout tool in a closed position in accordance with the present invention.

[0015] FIG. 2 illustrates a perspective view of a radial foldout tool in a closed position in accordance with the present invention.

[0016] FIG. 3 illustrates a perspective view of a radial foldout tool with a tool driver moving from a closed position to an open position in accordance with the present invention.

[0017] FIG. 4 illustrates a perspective view of a radial foldout tool in an open position in accordance with the present invention.

[0018] FIG. 5 illustrates a perspective view of a radial foldout tool with all of the tool drivers in an open or partially open position in accordance with the present invention.

[0019] FIG. 6A illustrates a perspective view of a radial foldout tool with alternative tool drivers in accordance with the present invention.

[0020] FIG. 6B illustrates a perspective view of a radial foldout tool with alternative tool drivers in accordance with the present invention.

[0021] FIG. 6C illustrates a perspective view of a radial foldout tool with alternative tool drivers in accordance with the present invention.

[0022] FIG. 7 illustrates a perspective view of a radial foldout tool with a plurality of faces in a closed position in accordance with the present invention.

[0023] FIG. 8A illustrates a first perspective view of a radial foldout tool having multiple tool drivers positioned on each face in a closed position in accordance with the present invention.

[0024] FIG. 8B illustrates a second perspective view of a radial foldout tool having multiple tool drivers positioned on each face in a closed position in accordance with the present invention.

[0025] FIG. 8C illustrates a third perspective view of a radial foldout tool having multiple tool drivers positioned on each face in a closed position in accordance with the present invention.

[0026] FIG. 8D illustrates a fourth perspective view of a radial foldout tool having multiple tool drivers positioned on each face in a closed position in accordance with the present invention.

[0027] FIG. 9 illustrates a perspective view of a radial foldout tool with a tool driver moving from a closed position to an open position in accordance with the present invention.

[0028] FIG. 10A illustrates a perspective view of a radial foldout tool in a 180° open position in accordance with the present invention.

[0029] FIG. 10B illustrates a perspective view of a radial foldout tool in a 90° open position in accordance with the present invention.

[0030] FIG. 11A illustrates a perspective view of a radial foldout tool with alternative tool drivers in accordance with the present invention.

[0031] FIG. 11B illustrates a perspective view of a radial foldout tool with alternative tool drivers in accordance with the present invention.

[0032] FIG. 11C illustrates a perspective view of a radial foldout tool with alternative tool drivers in accordance with the present invention.

DETAILED DESCRIPTION

[0033] In the following description, numerous details are set forth for purposes of explanation. However, one of ordinary skill in the art will realize that the invention may be practiced without the use of these specific details or with equivalent alternatives. Thus, the present invention is not intended to be limited to the embodiments shown but is to be accorded the widest scope consistent with the principles and features described herein.

[0034] Reference will now be made in detail to implementations of the present invention as illustrated in the accompanying drawings. The same reference indicators will be used throughout the drawings and the following detailed description to refer to the same or like parts.

[0035] Embodiments of the present invention are directed to a foldout tool that stores tool drivers in a compact configuration. The tool drivers are able to be positioned for use to tighten or loosen an object such as a screw or bolt.

Radial Foldout Tool

[0036] FIG. 1 illustrates an isometric view of a radial foldout tool 100 in a closed position in accordance with the present invention. A first set of tool drivers 108 is coupled to or near a first end 104 of a body 102 of the radial foldout tool 100. Each tool driver 112 of the first set of tool drivers 108 is coupled so that it is able to rotate out to an open position. In some embodiments, each of the first set of tool drivers 108, when stored in a closed position, fits securely within a different channel of the body 102. A second set of tool drivers 110 is coupled to or near a second end 106 of the body 102 of the radial foldout tool 100. Each tool driver 112 of the second set of tool drivers 110 is coupled so that it is

able to rotate out to an open position. In some embodiments, each of the second set of tool drivers **110**, when stored in a closed position, fits securely within a different channel of the body **102**.

[0037] In some embodiments, each of the tool drivers **112** of the first set of tool drivers **108** is positioned in the body **102** in a different plane from the other tool drivers of the first set of tool drivers **108**. Similarly, in some embodiments, each of the tool drivers **112** of the second set of tool drivers **110** is positioned in the body **102** in a different plane from the other tool drivers of the second set of tool drivers **110**. For example, in a radial foldout tool **100** which has a body **102** that is generally cylindrical in shape and surface, a first tool driver is positioned at 0° along the circumference of a round first end of the tool, a second tool driver is positioned at 120° along the circumference and a third tool driver is positioned at 240° along the circumference. Tool drivers are similarly positioned on the opposite end as well.

[0038] In some embodiments, each tool driver of the first set of tool drivers **108** is positioned in the same plane as a correspondingly positioned tool driver of the second set of tool drivers **110**.

[0039] In some embodiments, each of the tool drivers of the radial foldout tool **100** is configured to open at least perpendicularly to its neighboring tool driver. For example, with a radial foldout tool **100** containing three tool drivers at each end, a first tool driver opens at 0° , a second tool driver opens at 90° and a third tool driver opens at 270° . This configuration enables each of the tool drivers to open into/near the middle/center of the end, so that a user has better and easier turning power instead of the awkward turning capabilities when the tool drivers are not positioned near the middle of the end. In other words, each of the tool drivers fold out to a position as close as possible to a central axis of the radial foldout tool **100**.

[0040] In some embodiments, a hard stop such as an internal wall prevents the tool drivers from opening past a certain angle such as 180° so that the tool extends perpendicular to the corresponding end.

[0041] FIG. 2 illustrates a perspective view of a radial foldout tool **100** in a closed position in accordance with the present invention. A first set of tool drivers **108** is coupled to or near a first end **104** of a body **102** of the radial foldout tool **100**. The first set of tool drivers **108** is coupled so that the tool drivers **112** are able to rotate out to an open position. In some embodiments, each of the first set of tool drivers **108**, when stored in a closed position, fits securely within a different channel **114** of the body **102**. A second set of tool drivers **110** is coupled to or near a second end **106** of the body **102** of the radial foldout tool **100**. The second set of tool drivers **110** is coupled so that the tool drivers **112** are able to rotate out to an open position. In some embodiments, each of the second set of tool drivers **110**, when stored in a closed position, fits securely within a different channel **114** of the body **102**.

[0042] FIG. 3 illustrates a perspective view of a radial foldout tool **100** with a tool driver moving from a closed position to an open position in accordance with the present invention. When positioned in a closed position, the tool driver **112** is stored within a channel **114**, in some embodiments. A user is able to rotate the tool driver **112** to an open position as shown. In some embodiments, the tool driver **112** is limited in the direction it is able to rotate, such that it rotates away from the channel **114** in which it is stored.

Furthermore, the tool driver's rotational range is limited so that the tool driver **112** stops rotating once it is pointing in a parallel direction to the body **102**. In an open position, the tool driver **112** is also generally in the middle of the end of the body **102**. In other words, the tool driver **112** folds out to a position as close as possible to the central axis of the radial foldout tool **100**. To position the tool driver **112** in a closed position, a user rotates the tool driver **112** in an opposite direction from the opening direction so that the tool driver **112** rests within the channel **114**, in some embodiments.

[0043] FIG. 4 illustrates a perspective view of a radial foldout tool **100** in an open position in accordance with the present invention. When in an open position, a tool driver **112** is positioned pointing in a parallel direction to the body **102** and generally in the middle of the end of the body **102**, in some embodiments. This enables users to grip the body **102** as a handle and use the radial foldout tool **100** similarly to a screw driver or other tool that has a body with a tool driver protruding out of the middle of the handle. The radial foldout tool **100** is intended to be used with one of the tool drivers **112** in an open position. While one of the tool drivers **112** is in an open position, the other tool drivers **112** are typically in a closed position.

[0044] FIG. 5 illustrates a perspective view of a radial foldout tool **100** with all of the tool drivers in an open or partially open position in accordance with the present invention. The drawing of FIG. 5 is for illustration purposes only. When in use, the radial foldout tool **100** is designed to work with one tool driver open at a time.

[0045] In some embodiments, the radial foldout tool **100** is designed to include some hexagonal wrenches of English (e.g., standard) sizes including a $\frac{1}{4}$ inch hexagonal wrench, a $\frac{7}{32}$ inch hexagonal wrench, a $\frac{3}{16}$ inch hexagonal wrench, a $\frac{5}{32}$ inch hexagonal wrench, a $\frac{9}{64}$ inch hexagonal wrench, a $\frac{1}{8}$ inch hexagonal wrench, a $\frac{7}{64}$ inch hexagonal wrench, a $\frac{3}{32}$ inch hexagonal wrench and a $\frac{5}{64}$ inch hexagonal wrench.

[0046] In some embodiments, the radial foldout tool **100** is designed to include some hexagonal wrenches of metric sizes including an 8 mm hexagonal wrench, a 6 mm hexagonal wrench, a 5 mm hexagonal wrench, a 4 mm hexagonal wrench, a 3 mm hexagonal wrench, a 2.5 mm hexagonal wrench, a 2 mm hexagonal wrench and a 1.5 mm hexagonal wrench. It should be apparent to one skilled in the art that a radial foldout tool **100** is able to be formed to hold fewer, additional or different sizes of hexagonal wrenches.

[0047] In some embodiments, the radial foldout tool **100** is designed to be of a round shape. In some embodiments, the radial foldout tool **100** is designed to be of a triangular shape including three faces, a square or rectangle shape including four faces, a hexagonal shape including six faces or any other appropriate shape. In some embodiments, a single tool driver is positioned on each face of the radial foldout tool **100**. In some embodiments, each face is approximately 1 inch across its width and the body **102** of the radial foldout tool **100** is approximately 4.5 inches in length. The body **102** is designed to provide a comfortable, user-friendly interface to a user's hand, in order to enhance a user's ability to exert rotational pressure on the tool driver **112** without subjecting the user to personal injury or requiring the use of additional tools. As should be apparent to one

skilled in the art, the body **102** of the present invention may be designed to be of any convenient shape, including any number of faces.

[0048] FIGS. **6A**, **6B** and **6C** each illustrates a perspective view of a radial foldout tool with alternative tool drivers in accordance with the present invention. FIG. **6A** illustrates a radial foldout tool **100'** with screwdrivers as tool drivers **112'**. The body **102** is similar to or the same as embodiments above with two opposing ends **104** and **106**. Additionally, the channels **114** are also similar to or the same as embodiments above. However, in this embodiment, a first set of tool drivers **108'** includes flat head screwdrivers, and the second set of tool drivers **110'** includes phillips head screwdrivers. In some embodiments, the sizes and/or shapes of the heads of the screwdrivers vary. For example, the sizes of the screwdriver heads are able to vary to small enough for use with a tiny screw for securing eyeglass components together up to much larger screws. Also, for varying shapes, at times a more pointed screwdriver is necessary for a screw while other times a flatter screwdriver is necessary or preferred. The thickness of the screwdriver tip varies, in some embodiments. In some embodiments, the first set and the second set of tool drivers are all flat head screwdrivers or phillips head screwdrivers. Any variations of screwdrivers are possible.

[0049] FIG. **6B** illustrates a radial foldout tool **100''** with star-shaped drivers as tool drivers **112''**. As described above in reference to FIG. **6A**, the body **102** with two opposing ends **104** and **106** is similar to or the same as well as the channels **114** for previous embodiments. However, in this embodiment, the first and second sets of tool drivers **108''** and **110''** are star-shaped drivers. The star-shaped drivers vary in size, tip recess (security star) and/or any other characteristic.

[0050] FIG. **6C** illustrates a radial foldout tool **100'''** with both screwdrivers and hexagonal wrenches as tool drivers. Again, the body **102** with two opposing ends **104** and **106** and the channels **114** are similar to or the same as in previous embodiments. However, instead of simply having one type of tool driver, such as hexagonal wrenches, multiple sets of tool drivers are included such as hexagonal wrenches and screwdrivers. In the embodiment shown, a first set of tool drivers **108** includes hexagonal wrenches and a second set of tool drivers **110'** includes screwdrivers. Furthermore, the screwdrivers are able to be one type of screwdriver with varying shapes and sizes, and/or are able to include multiple types of screwdrivers such as flat heads and phillips head screwdrivers. While an example of a radial foldout tool with screwdrivers and hexagonal wrenches has been shown, other types of combination tools are possible such as screwdrivers and star-shaped drivers, hexagonal wrenches and star-shaped drivers, hexagonal wrenches and socket wrenches, combinations of three or more tool drivers or any other combinations of tool drivers.

[0051] FIG. **7** illustrates a perspective view of a radial foldout tool **200** with a plurality of faces in a closed position in accordance with the present invention. A first set of tool drivers **208** is coupled to or near a first end **204** of a body **202** of the radial foldout tool **200**. The first set of tool drivers **208** is coupled so that the tool drivers **208** are able to rotate out to an open position. In some embodiments, each of the first set of tool drivers **208**, when stored in a closed position, fits securely within a different channel **214** of the body **202**. A second set of tool drivers **210** is coupled to or near a second end **206** of the body **202** of the radial foldout tool **200**. The

second set of tool drivers **210** is coupled so that the tool drivers **212** are able to rotate out to an open position. In some embodiments, each of the second set of tool drivers **210**, when stored in a closed position, fits securely within a different channel **214** of the body **202**. In some embodiments, some of the faces contain two or more tool drivers. In some embodiments, each of the faces contains a single tool driver. As described in detail below, in other embodiments, each of the faces contain at least one tool driver.

[0052] As described in this section, the tool drivers in some embodiments are configured to rotate to an open position which is generally in the middle/center of each end of the body of the radial foldout tool. In other words, the tool drivers each folds out to a position as close as possible to a central axis of the radial foldout tool. By being near the middle of each end, turning the radial foldout tool is more stable for a user when the radial foldout tool is in use and each of the tool drivers is in use. The tool drivers are also stored in a plurality of planes in the body which help ensure the tool drivers open to the middle of each end. Since the tool drivers are stored in a plurality of planes, the tool drivers open in a direction at least perpendicular to their neighboring tool driver to further ensure they open to the middle of each end of the radial foldout tool. Previously existing foldout tools suffer from an awkward grasping implementation where the awkwardness is due to the fact that, in the worst case, for example, the previously existing tools allow for the smallest of wrenches to place the part of the tool that is grasped and turned, as far off-axis as possible (and without the benefit of a hard stop in the fully extended position as the present radial foldout tool does). In addition to that, since the previously existing tools are rectangular cubes, the user's hand is required to either fully disengage the tool between turns, or to use rather involved spider-like, alternating stepping actions with the fingers to crawl the hand around the tool into position for the next twist, all the while, keeping the tool stabilized in multiple axes due to the fact that the grasp is compromised and that the wrench, when fully extended, is able to rotate at least 270°. Whereas, with the present radial foldout tool design, the user's hand is able to simply loosen the grasp and slide the palm around within the circumference of the tool while maintaining a steady and sure grasp on the tool, wrench and fastener.

Biaxial Foldout Tool

[0053] As described above, in some embodiments, multiple tool drivers are positioned on each face of a foldout tool. FIGS. **8A**, **8B**, **8C** and **8D** each illustrate a perspective view of a biaxial foldout tool **300** having multiple tool drivers positioned on each face in a closed position in accordance with the present invention. The biaxial foldout tool **300** has a body **302** that generally includes four faces; a first face is opposite of a third face, and a second face is opposite of a fourth face. FIG. **8A** illustrates a first perspective view of the biaxial foldout tool **300** showing the first face and the fourth face. FIG. **8B** illustrates a second perspective view of the biaxial foldout tool **300** showing the first face and the second face. FIG. **8C** illustrates a third perspective view of the biaxial foldout tool **300** showing the second face and the third face. FIG. **8D** illustrates a fourth perspective view of the biaxial foldout tool **300** showing the third face and the fourth face.

[0054] In some embodiments, a first set of tool drivers **308** is coupled to or near a first end **304** of the body **302** of the

biaxial foldout tool **300**. Each tool driver **312** of the first set of tool drivers **308** is coupled so that it is able to rotate out to an open position via a first hinge **316**. In some embodiments, when the first set of tool drivers **308** is stored in a closed position, tool drivers **312** fit securely within channels **314** of the body **302**. A second set of tool drivers **310** is coupled to or near a second end **306** of the body **302** of the biaxial foldout tool **300**. Each tool driver **312** of the second set of tool drivers **310** is coupled so that it is able to rotate out to an open position via a second hinge **318**. In some embodiments, when the second set of tool drivers **310** is stored in a closed position, tool drivers **312** fit securely within channels **314** of the body **302**.

[0055] In some embodiments, each tool driver **312** of the first set of tool drivers **308** is configured to fully open in parallel with the body **302** and an opposite direction of the other tool drivers **312** in the first set of tool drivers **308**. Similarly, in some embodiments, each tool driver **312** of the second set of tool drivers **310** is configured to fully open in parallel direction with the body **302** and an opposite direction of the other tool drivers **312** in the second set of tool drivers **310**.

[0056] In some embodiments, while each tool driver **312** of the first set of tool drivers **308** rotates about the first hinge **316**, a first portion **308a** of the first set of tool drivers **308** fits securely within a channel **314** on the first face of the biaxial foldout tool **300**, and a second portion **308b** of the first set of tool drivers **308** fit securely within a channel **314** on the third face of the biaxial foldout tool **300**. The tool drivers **312** of the first portion **308a** open in a direction counter to the direction of the tool drivers **312** of the second portion **308b**. Similarly, in some embodiments, while each tool driver **312** of the second set of tool drivers **310** rotates about the second hinge **318**, a first portion **310a** of the second set of tool drivers **310** fits securely within a channel **314** on the second face of the biaxial foldout tool **300**, and a second portion **310b** of the second set of tool drivers **310** fits securely within a channel **314** on the fourth face of the biaxial foldout tool **300**. The tool drivers **312** of the first portion **310a** open in a direction counter to the direction of the tool drivers **312** of the second portion **310b**.

[0057] The first hinge **316** typically couples together the second face and the fourth face. The second hinge **318** typically couples together the first face and the third face. In other words, the ends **304**, **306** of the biaxial foldout tool **300** are rotated or twisted approximately 90° from each other, such that ends of each hinge are on each face of the biaxial foldout tool **300**. Although the biaxial foldout tool **300** has four faces, the 90° rotation creates a more cylindrical body, thereby providing a user with a better grasp of the biaxial foldout tool **300** while tightening or loosening an object such as a screw or bolt.

[0058] The biaxial foldout tool **300** in some embodiments is designed to include some hexagonal wrenches of English (e.g., standard) sizes. In some embodiments, the first portion **308a** of the first set of tool drivers **308** includes a $\frac{3}{16}$ inch hexagonal wrench and a $\frac{7}{32}$ inch hexagonal wrench, while the second portion **308b** of the first set of the tool driver **308** includes a $\frac{1}{4}$ inch hexagonal wrench. In some embodiments, the first portion **310a** of the second set of tool drivers **310** includes a $\frac{9}{64}$ inch hexagonal wrench and a $\frac{5}{32}$ inch hexagonal wrench, while the second portion **310b** of the second set of the tool driver **310** includes a $\frac{5}{64}$ inch

hexagonal wrench, $\frac{3}{32}$ inch hexagonal wrench, $\frac{7}{64}$ inch hexagonal wrench, and $\frac{1}{8}$ inch hexagonal wrench.

[0059] The biaxial foldout tool **300** in other embodiments is designed to include some hexagonal wrenches of metric sizes. In some embodiments, the first portion **308a** of the first set of tool drivers **308** includes a 5 mm hexagonal wrench and a 6 mm hexagonal wrench, while the second portion **308b** of the first set of the tool driver **308** includes an 8 mm hexagonal wrench. In some embodiments, the first portion **310a** of the second set of tool drivers **310** includes a 4 mm hexagonal wrench and a 4.5 mm hexagonal wrench, while the second portion **310b** of the second set of the tool driver **310** includes a 2 mm hexagonal wrench, 2.5 mm hexagonal wrench, 3 mm hexagonal wrench, and a 3.5 mm hexagonal wrench. It should be apparent to one skilled in the art that a biaxial foldout tool **300** is able to be formed to hold fewer, additional or different sizes of hexagonal wrenches.

[0060] In some embodiments, the tool drivers are grouped into sets depending on a predetermined characteristic such as size. For example, each tool driver of a set of tool drivers is larger than each tool driver of another set of tool drivers. In addition or alternatively, each tool driver of a portion of a set of tool drivers is positioned within a channel **314** in a predetermined order such as size. For example, a largest tool driver of a portion is positioned towards a centerline of the body **300**, and a smallest tool driver is positioned towards an outside of the channel **314**. As such, in an open position, the largest tool driver is generally in the middle of the body **302**. Having the largest tool driver generally in the middle of the body **302** advantageously provides a more even torque during usage. Alternatively, the largest tool driver of a portion is positioned towards the outside of the channel **314**, and the smallest tool driver is positioned towards the inside of the channel **314**.

[0061] FIG. 9 illustrates a perspective view of a biaxial foldout tool **300** with a tool driver moving from a closed position to an open position in accordance with the present invention. When positioned in a closed position, the tool driver **312** is stored within a channel **314**, in some embodiments. A user is able to rotate the tool driver **312** to an open position as shown. In some embodiments, the tool driver **312** is limited in the direction it is able to rotate, such that it rotates away from the channel in which it is stored. Furthermore, the tool driver's rotational range is limited so that the tool driver **312** stops rotating once it is pointing in a parallel direction to the body **302**. In some embodiments, a hard stop such as an internal wall **320** prevents the tool driver from opening past a predetermined angle such as 90° or 180°. To position the tool driver **312** in a closed position, a user rotates the tool driver **312** in an opposite direction from the opening direction so that the tool driver **312** rests within the channel **314**, in some embodiments.

[0062] FIG. 10A illustrates a perspective view of a biaxial foldout tool **300** in a 180° open position in accordance with the present invention. When in a 180° open position, a tool driver **312** is positioned pointing in a parallel direction to the body **302**. This enables users to grip the body **302** as a handle and use the biaxial foldout tool **300** similarly to a screw driver or other tool that has a body with a tool driver protruding out of the middle of the handle. The biaxial foldout tool **300** is intended to be used with one of the tool **312** in a 180° open position. While one of the tool drivers **312** is in a 180° open position, the other tool drivers **312** are in a closed position.

[0063] FIG. 10B illustrates a perspective view of a biaxial foldout tool 300 in a 90° open position in accordance with the present invention. When in a 90° open position, a tool driver 312 is positioned pointing in a perpendicular direction to the body 302. The user is able to grip the body 302 as a handle during, for example, the starting and/or the finishing of hardware since the user is able to generate the most torque using this configuration. The biaxial foldout tool 300 is intended to be used with one of the tool drivers 312 in a 90° open position. While one of the tool drivers 312 is in a 90° open position, the other tool drivers 312 are in a closed position.

[0064] FIGS. 11A, 11B and 11C each illustrates a perspective view of a biaxial foldout tool with alternative tool drivers. FIG. 11A illustrates a biaxial foldout tool 300' with flat head screwdrivers as tool drivers 312'. FIG. 11B illustrates a biaxial foldout tool 300'' with phillips head screwdrivers as tool drivers 312''. FIG. 11C illustrates a biaxial foldout tool 300''' with both flat head screwdrivers and phillips screwdrivers as tool drivers 312'''; the flat head screwdrivers are part of a first set of tool drivers 308''' and the phillips head screwdrivers are part of a second set of tool drivers 310'''. As illustrated, the biaxial foldout tool 300', the biaxial foldout tool 300'' and the biaxial foldout tool 300''' are similarly configured as the biaxial foldout tool 300, except that the tool drivers are different. It should be understood that different combinations of tool drivers are possible. It should also be understood that each tool driver can be different from the other tool drivers.

[0065] As described in this section, the tool drivers in some embodiments are configured to rotate to an open position via hinges. Each side of the body of the biaxial foldout tool contains at least one tool driver. Since the ends of the biaxial foldout tool are rotated approximately 90° from each other, the body is more cylindrical in shape, providing a user with a better grasp of the biaxial foldout tool as compared to previously existing tools that are rectangular cubes. Furthermore, a more cylindrical shape advantageously allows for more tool drivers to be coupled to the biaxial foldout tool as one unit.

Composition of the Body

[0066] A body of a foldout tool (e.g., radial or biaxial) is able to be composed of any appropriate material, which is of maximum strength and includes properties which resist materials that the handle will likely be exposed to, e.g., oil, grease, gasoline and the like. In some embodiments, the body is materially composed of 30% glass-filled polypropylene or nylon. In some embodiments, the body is materially composed of any suitable composition including, but not limited to aluminum or steel. In some embodiments, tool drivers are materially composed of aluminum, steel or any other appropriate material. In some embodiments, the body is constructed using an injection molded, core/cavity process as is well known in the art. Alternatively, the body may be constructed in any known manner.

Operation

[0067] In operation, a foldout tool (e.g., radial or biaxial) contains multiple tool drivers to consolidate the space needed for a set of tool drivers. Furthermore, the body of the foldout tool contains channels for storing the tool drivers in a closed position, so that more tools are able to be stored. To utilize the foldout tool, a user moves a desired tool driver

from a closed position to an open position. In some embodiments, the open position is at 90° (e.g., the desired tool driver is perpendicular to the body). In other embodiments, the open position is at 180° (e.g., the desired tool driver is parallel to the body). The user moves the desired tool driver using a finger or two to simply pull or push the tool driver in the appropriate direction. In some embodiments, the tool driver locks into place in the open position. The user then grasps the body of the foldout tool similarly to grasping a handle of a screwdriver. The user turns the body of the foldout tool to either tighten or loosen an object such as a screw or bolt. This turning action is also similar to the use of a screwdriver. Once the user has performed the tightening or loosening actions on the desired object or objects, the tool driver is moved to a closed position by pushing or pulling the tool driver with the user's fingers. In some embodiments, the tool drivers lock in the closed position. When in the closed position, the tools are safely stored within channels in the body to prevent injuries. Unlike a standard screwdriver which has a sharp point jutting out of the handle, the foldout tool is able to be compacted and stored safely.

[0068] The present invention has been described in terms of specific embodiments incorporating details to facilitate the understanding of principles of construction and operation of the invention. Such reference herein to specific embodiments and details thereof is not intended to limit the scope of the claims appended hereto. It will be readily apparent to one skilled in the art that other various modifications may be made in the embodiment chosen for illustration without departing from the spirit and scope of the invention as defined by the appended claims.

1-23. (canceled)

24. A utility tool comprising:

- a. a first end comprising a first hinge and one or more tool drivers configured to rotate about the first hinge in a plurality of different directions; and
- b. a second end comprising a second hinge non-parallel to the first hinge and one or more tool drivers configured to rotate about the second hinge.

25. The utility tool of claim 24 wherein the one or more tool drivers of the first end and the one or more tool drivers of the second end are grouped according to size.

26. The utility tool of claim 24 wherein the tool comprises an internal stop configured to prevent the one or more tool drivers of the first end and the one or more tool drivers of the second end from opening past an angle.

27. The utility tool of claim 24 wherein the second hinge is rotated 90° in orientation from the first hinge.

28. The utility tool of claim 24 wherein the one or more tool drivers of the first end and the one or more tool drivers of the second end are stored in one or more channels of the utility tool when not in use.

29. The utility tool of claim 24 wherein the first end and the second end each comprise one or more tool drivers on a first side and a second side opposite the first side.

30. The utility tool of claim 29 wherein the tool drivers of the first side and the one or more tool drivers of the second side open in opposite directions.

31. A utility tool comprising:

- a. a first end and a second end;
- b. a first hinge coupled to the first end;
- c. a second hinge coupled to the second end;
- d. a first tool driver configured to rotate to an open position about the first hinge;

e. a second tool driver configured to rotate to an open position about the first hinge and in an opposite direction from the first tool driver; and

f. a third tool driver configured to rotate to an open position about the second hinge.

32. The utility tool of claim **31** wherein the tool drivers are grouped according to size.

33. The utility tool of claim **31** wherein the tool comprises an internal stop configured to prevent the tool drivers from opening past an angle.

34. The utility tool of claim **31** wherein the tool drivers are stored within one or more channels when not in use.

35. A utility tool comprising:

a. a body comprising a first end, a second end and a plurality of sides; and

b. a first channel and a second channel each holding one or more rotatable tool drivers, and wherein the first channel and the second channel are on opposite sides of the first end.

36. The utility tool of claim **35** wherein the one or more rotatable tool drivers of the first channel and the one or more rotatable tool drivers of the second channel are configured to rotate in opposite directions to an operative position.

37. The utility tool of claim **36** wherein the one or more rotatable tool drivers of the first channel and the one or more rotatable tool drivers of the second channel rotate about a same first hinge.

38. The utility tool of claim **37** comprising a second hinge non-parallel to the first hinge and one or more tool drivers configured to rotate about the second hinge.

39. The utility tool of claim **35** wherein the second hinge is rotated 90° in orientation from the first hinge.

40. The utility tool of claim **35** wherein the tool drivers are grouped according to size.

41. The utility tool of claim **35** wherein the tool comprises an internal stop configured to prevent the tool drivers from opening past an angle.

* * * * *