



US 20170266877A1

(19) **United States**

(12) **Patent Application Publication**
TYLER

(10) **Pub. No.: US 2017/0266877 A1**

(43) **Pub. Date: Sep. 21, 2017**

(54) **METHOD AND APPARATUS FOR
CONTINUOUS COMPOSITE THREE
DIMENSIONAL PRINTING**

(71) Applicant: **CC3D LLC**, Coeur d'Alene, ID (US)

(72) Inventor: **KENNETH LYLE TYLER**, Coeur
d'Alene, ID (US)

(73) Assignee: **CC3D LLC**, Coeur d'Alene, ID (US)

(21) Appl. No.: **15/610,960**

(22) Filed: **Jun. 1, 2017**

Related U.S. Application Data

(63) Continuation of application No. 15/267,956, filed on
Sep. 16, 2016, which is a continuation of application
No. 13/975,300, filed on Aug. 24, 2013, now Pat. No.
9,511,543.

(60) Provisional application No. 61/694,253, filed on Aug.
29, 2012, provisional application No. 61/694,253,
filed on Aug. 29, 2012.

Publication Classification

(51) **Int. Cl.**
B29C 67/00 (2006.01)
B29B 15/12 (2006.01)
B33Y 30/00 (2006.01)
(52) **U.S. Cl.**
CPC *B29C 67/0055* (2013.01); *B33Y 30/00*
(2014.12); *B29B 15/122* (2013.01); *B29K*
2105/12 (2013.01)

(57) **ABSTRACT**

A method and apparatus for the additive manufacturing of three-dimensional objects are disclosed. Two or more materials are extruded simultaneously as a composite, with at least one material in liquid form and at least one material in a solid continuous strand completely encased within the liquid material. A means of curing the liquid material after extrusion hardens the composite. A part is constructed using a series of extruded composite paths. The strand material within the composite contains specific chemical, mechanical, or electrical characteristics that instill the object with enhanced capabilities not possible with only one material.

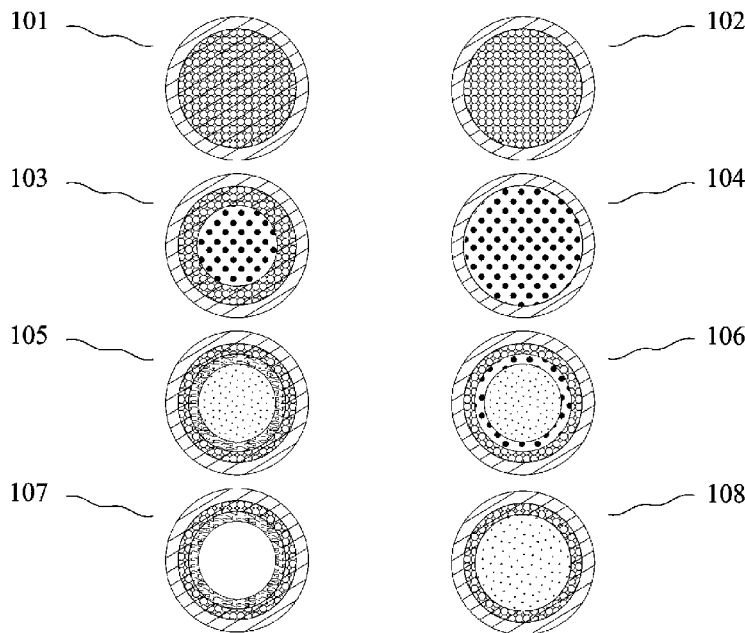

KEY

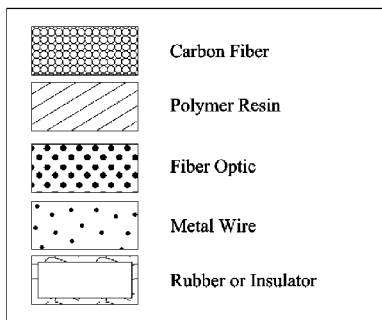

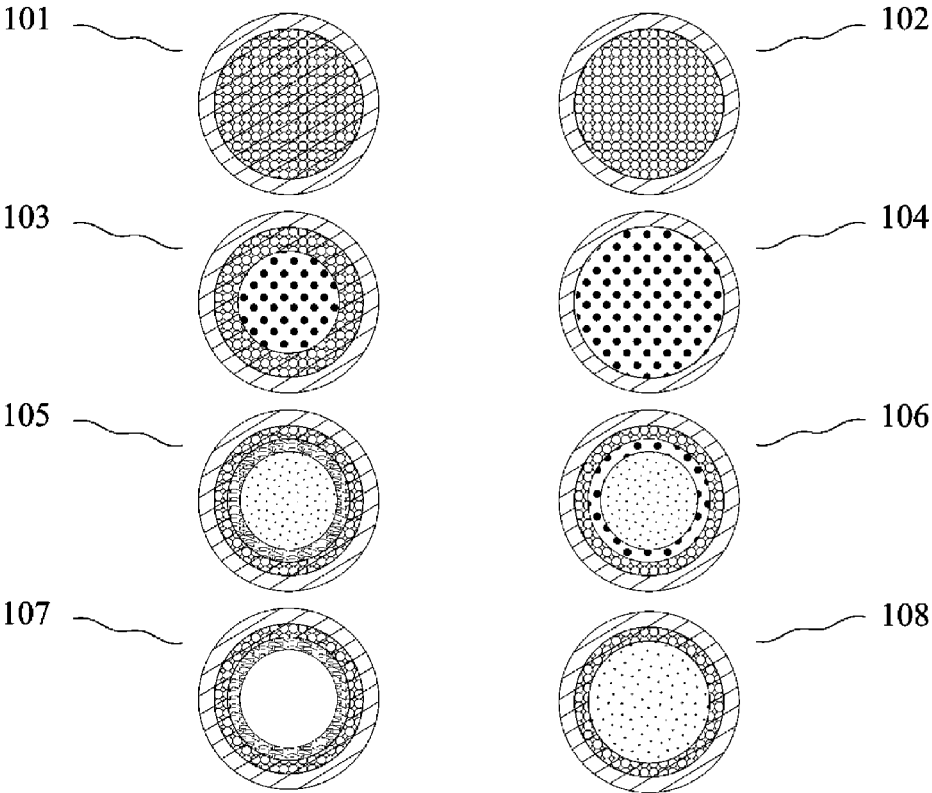

KEY	
	Carbon Fiber
	Polymer Resin
	Fiber Optic
	Metal Wire
	Rubber or Insulator

Fig. 1

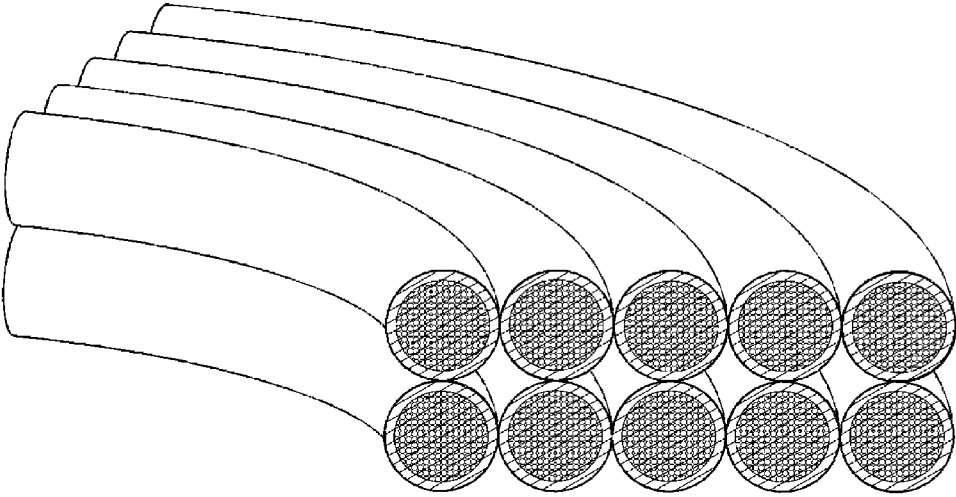
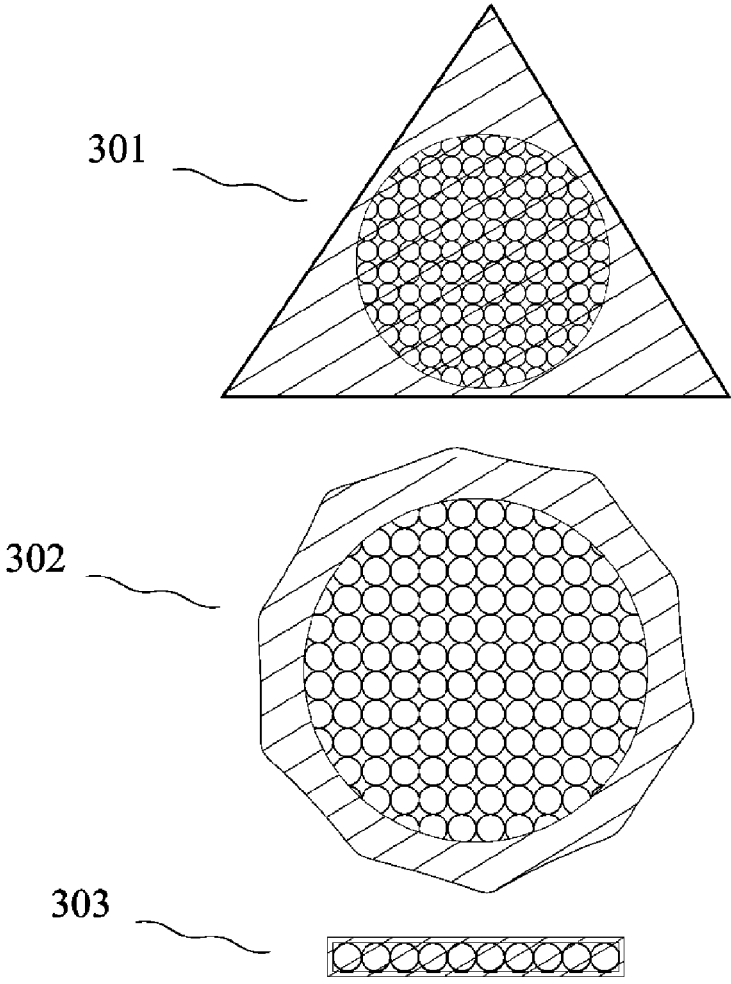

Fig. 2



KEY	
	Carbon Fiber
	Polymer Resin
	Fiber Optic
	Metal Wire
	Rubber or Insulator

Fig. 3

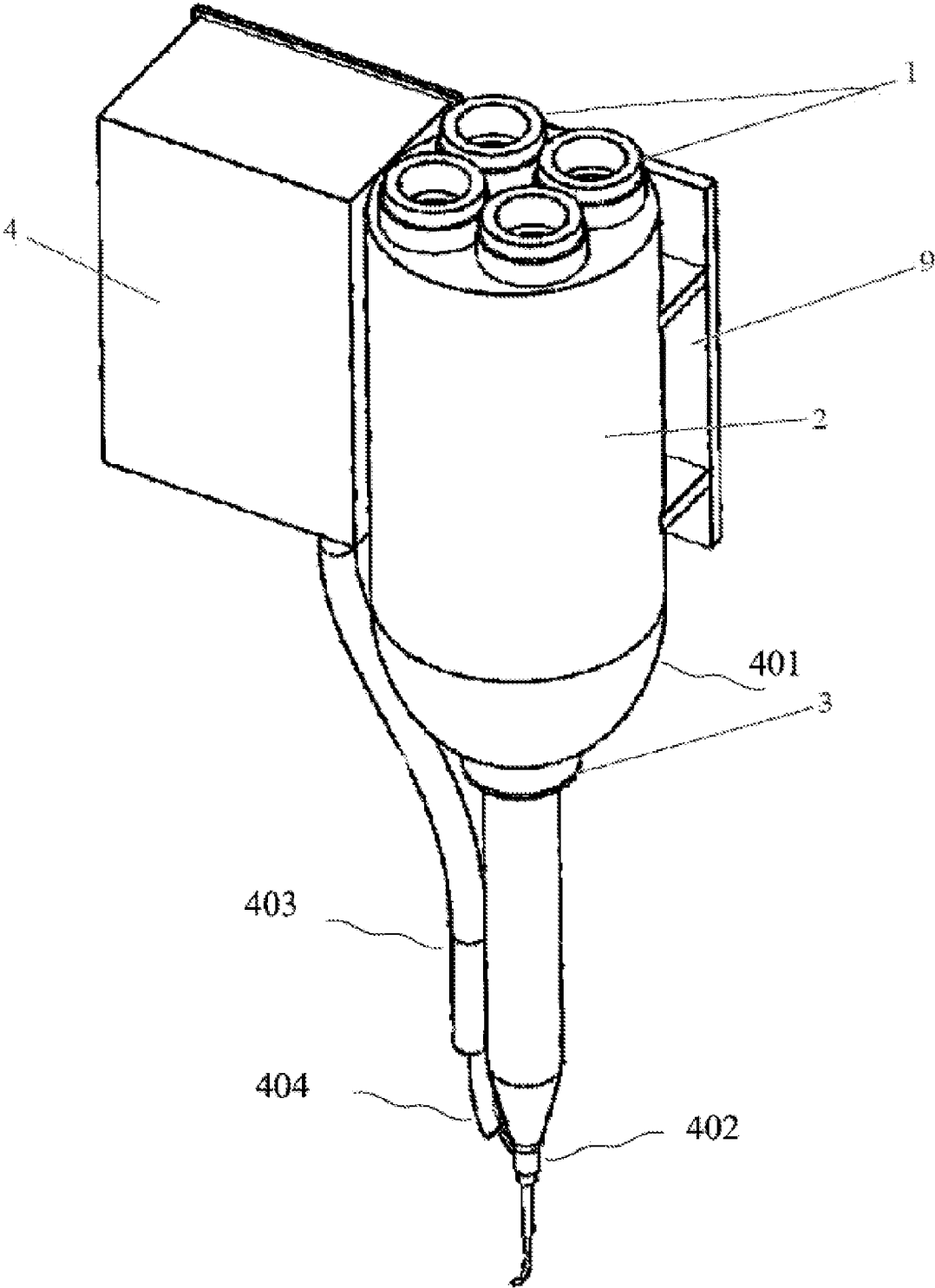

Fig. 4

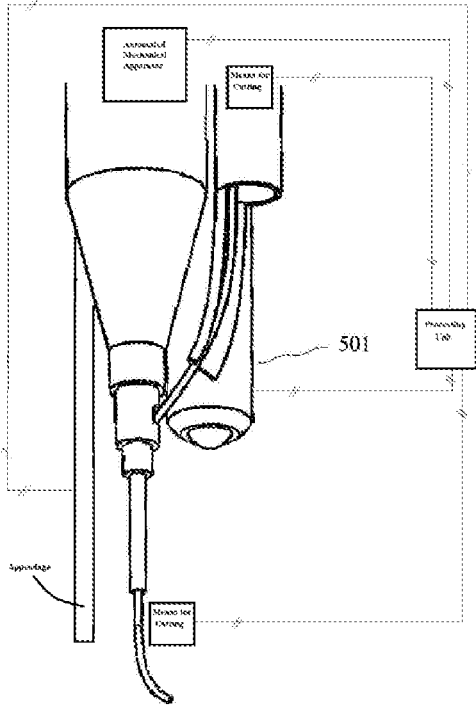

Fig. 5

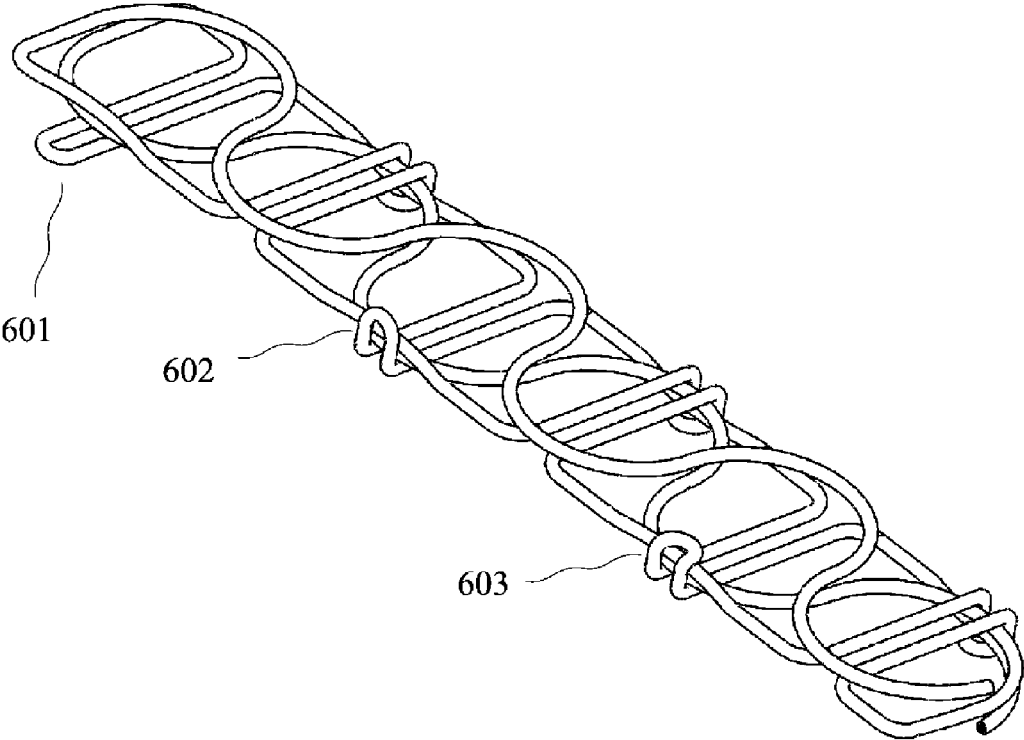

Fig. 6

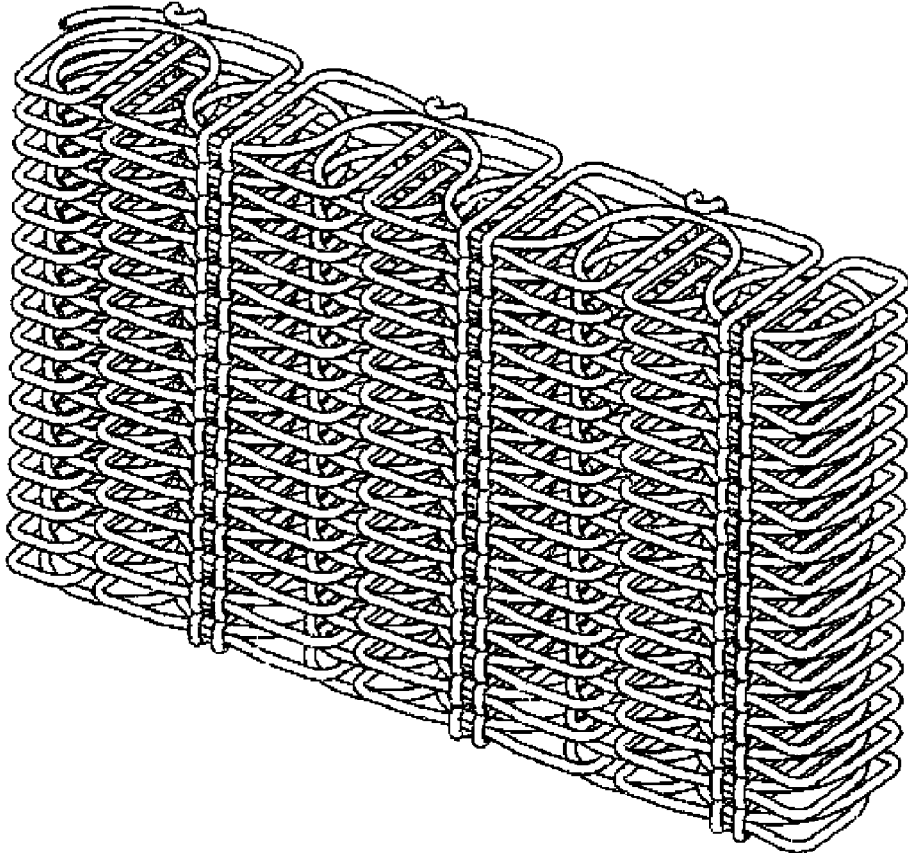

Fig. 7

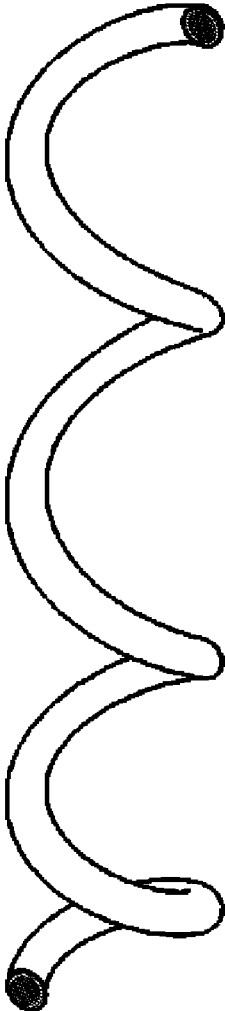

Fig. 8

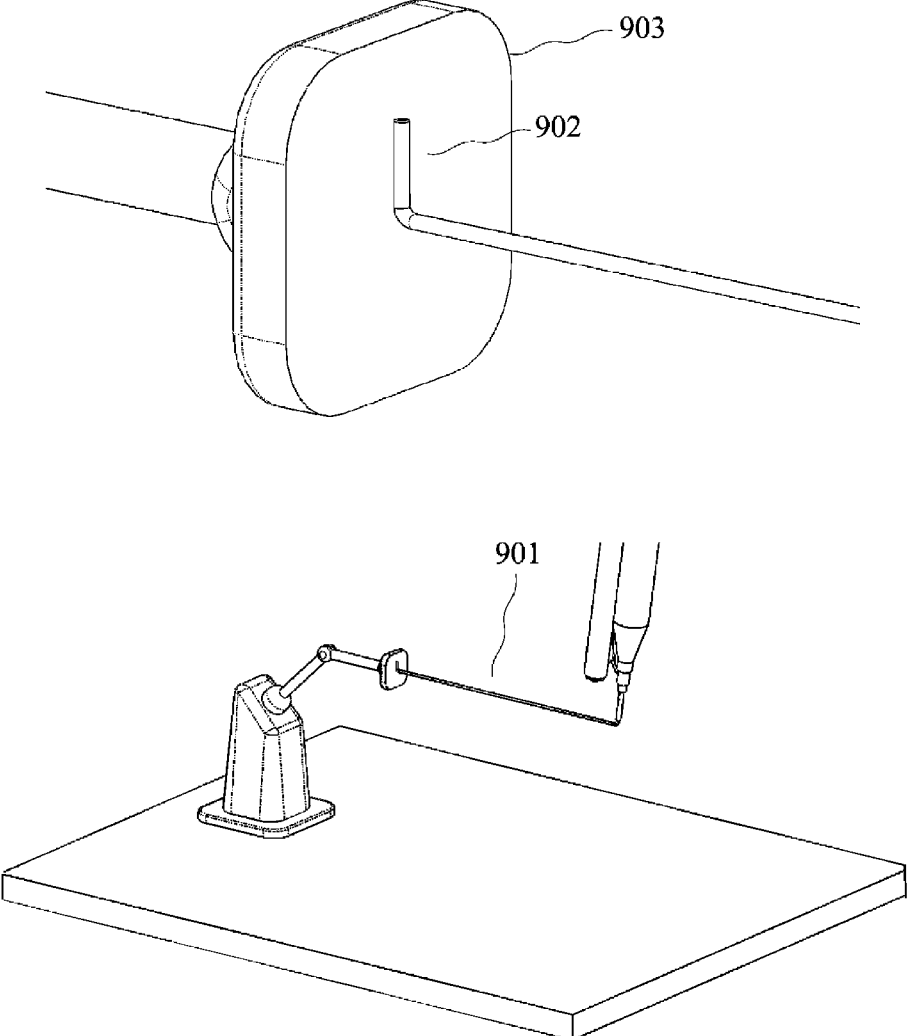

Fig. 9

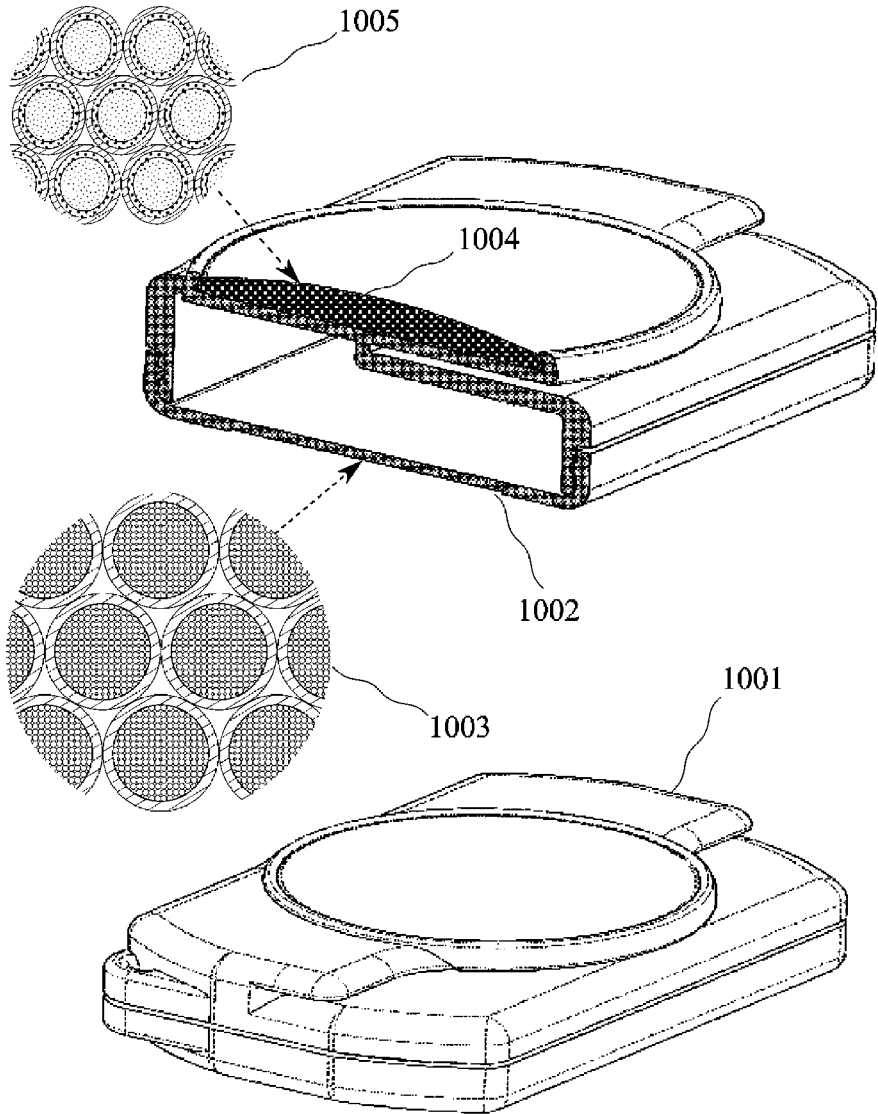

Fig. 10

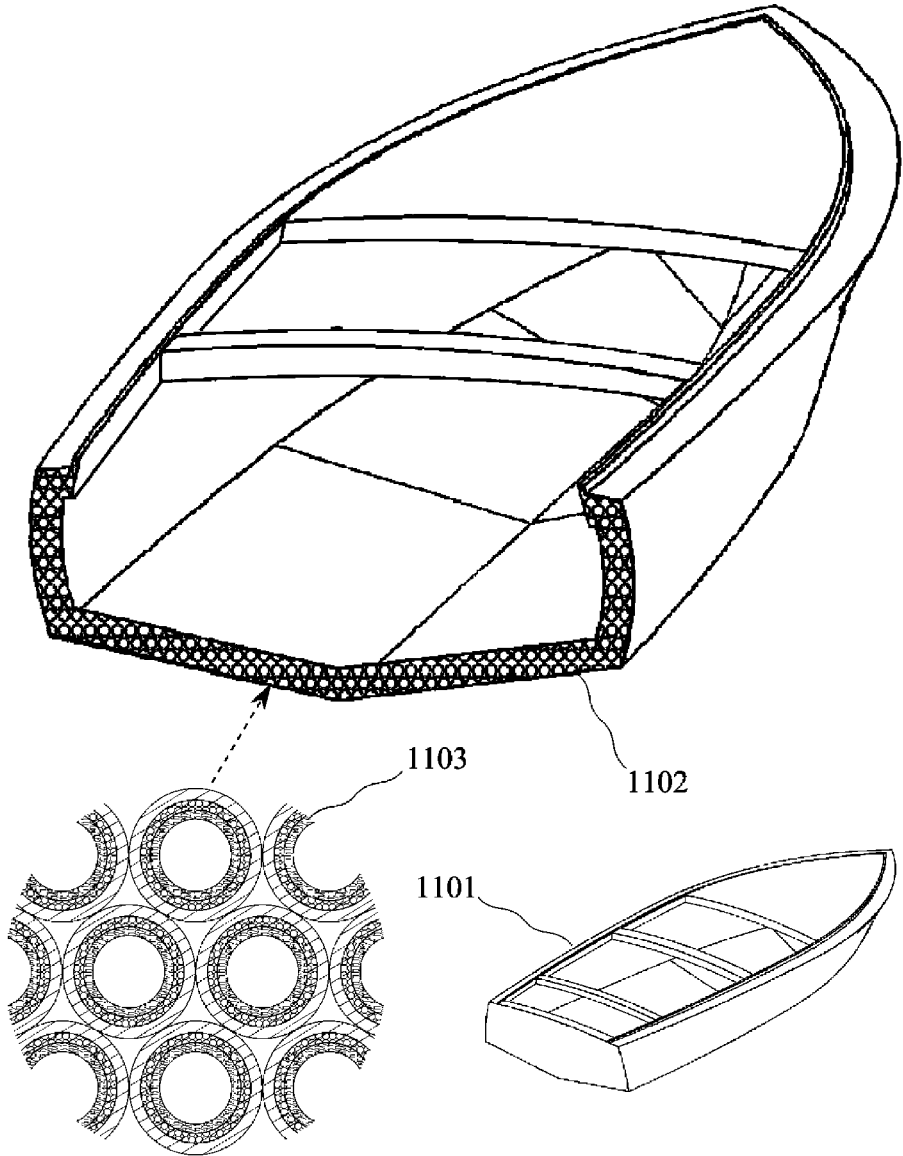

Fig. 11

METHOD AND APPARATUS FOR CONTINUOUS COMPOSITE THREE DIMENSIONAL PRINTING

RELATED APPLICATIONS

[0001] This application is a continuation of, and claims the benefit of priority to, application Ser. No. 15/267,956 filed on Sep. 16, 2016; which is a continuation of, and claims the benefit of priority to, application Ser. No. 13/975,300 that was filed on Aug. 24, 2013; which is based on and claims the benefit of priority from U.S. Provisional Application No. 61/694,253 that was filed on Aug. 29, 2012, the contents of all of which are expressly incorporated herein by reference.

BACKGROUND

[0002] Additive Manufacturing is a process that creates physical parts from a three-dimensional digital file. The current most common additive manufacturing techniques include stereo lithography (SLA) and selective laser sintering (SLS). These processes build a three-dimensional part by converting the digital file into several horizontal layers. For the sake of clarity, this application refers to each layer of an additive manufactured part created by SLA or SLS as a slice. The base slice is created, and then successive slices are added one at a time on top of each other, building the part from the bottom up.

[0003] SLA performs this method by extruding liquid resin, which is curable with a UV laser. The resin is extruded first in the base slice, and then a UV light cures and solidifies the slice. Another slice is extruded atop that slice, and cured. This process continues adding slices upon each other until the part is complete.

[0004] SLS uses a reductive technique. A layer of small particles, comparable to powder or sand, is placed on a printing surface. The particles may be plastic, metal, glass, or other material. A laser draws the first slice of the part in the particles, fusing them together to form the base of the part. Another layer of particles are then added across the entire printing surface. The laser then fuses the newly added particles together in the desired shape of the next slice. More particles are added, and the laser fuses more slices until the entire part is fused. The part is then removed from the loose particles.

[0005] Additionally there are other additive manufacturing techniques similar to SLS that use a binder material, instead of a laser, to fuse particles together. It still builds the part with a slicing technique, starting from the base and adding slices one at a time.

[0006] To strengthen the parts, some additive manufacturing techniques add reinforcing particles. This creates a heterogeneous mixture rather than pure resin, plastic, or metal. The reinforcing particles are randomly distributed throughout the part. A comparable application is the addition of aggregate to cement to create concrete.

[0007] The additive manufacturing techniques described above have several disadvantages. The process of building parts layer by layer is slow, and necessitates parts being designed to accommodate the slicing process. The parts are built slice upon slice, with vulnerable joints between each, creating a relatively weak part. Additionally, the materials used are mostly homogeneous plastic or resin, with a minor-

ity of manufacturers adding reinforcing particles. These materials have much room for improvement with regard to strength and efficiency.

[0008] There is a need for a method and apparatus of additive manufacturing that builds parts faster and easier than the current slicing methods, and also creates stronger parts than the current single or composite materials in use.

SUMMARY

[0009] A method and apparatus for additive manufacturing are described below. The new method is called Continuous Composite Three Dimensional Printing (CC3D). This method enables the additive manufacturing of parts utilizing two or more materials, and uses an alternate means of building parts with paths rather than slices. This affords stronger lighter parts, with flexibility in structure, design, and functionality. Throughout this application, the term part refers to any three-dimensional object created by additive manufacturing.

[0010] The method allows for two or more materials simultaneously incorporated into the construction of a part. There is at least one primary material and at least one secondary material. The primary material is a curable liquid, the best mode being a photosensitive resin. The second material is a solid strand. The strand may be any material, the best mode being carbon fiber. These two materials are extruded together, with the secondary material fully encased within the primary material.

[0011] Together, the primary material and the at least one secondary material are called the composite material. An extruder emits the composite material in a continuous path. As the composite material is extruded, a means for curing, possibly a UV light, hardens the composite material.

[0012] Instead of the slicing method described in the background, the invention uses a pathing method. A digital model of the part is analyzed and broken up into paths. A part may contain only one path, or multiple paths. Each path is one continuous extrusion of the composite material. When a path is completed, the composite material is cut and additional paths may be printed to create the part.

[0013] The combination of composite material and pathing adds strength to the part. Slicing creates several layers of a single material stacked upon each other. Only a chemical bond between slices, or gravity, holds the part together. By adding a continuous secondary material, an additional mechanical structure stabilizes the part.

[0014] The use of composites also more efficiently uses the primary material. The surface tension created between the secondary and primary materials allows for the minimal use of primary material. For example, a higher carbon fiber to resin ratio allows parts to be lighter, less costly, stronger, and more flexible. The inclusion of a hollow tube as the secondary material also has similar weight, flexibility, and efficiency benefits.

[0015] The composite material may be several alternative embodiments. The primary material can be any liquid material suitable for extruding and curing. The secondary material can be any material in the form of a strand. Examples of potential secondary materials include carbon fiber, fiber optics, metal wire, or a hollow rubber tube. Additionally, the secondary material may be a combination of materials. An example could be metal wire within a rubber tube.

[0016] The use of CC3D with various composites, allows for increased flexibility in design and function. Composite

material adds strength during the manufacturing, allowing paths to extend in three dimensions, rather than only along horizontal planes. This gives the designer flexibility in creating parts.

[0017] Additionally, the secondary material provides alternative functions not currently supported by additive manufacturing. The use of fiber optics or other conductive materials in continuous strands, affords the creation of parts with electronic capabilities. A part may have integrated circuitry, or a conductive surface, allowing designers to print what may be termed intelligent parts and parts with intelligent surfaces.

BRIEF DESCRIPTION OF THE DRAWINGS

[0018] FIG. 1 is a set of example cross-sections of continuous composite paths, showing alternative primary and secondary materials.

[0019] FIG. 2 is a section cut of a simple part with multiple paths.

[0020] FIG. 3 is a set of example cross-sections of continuous composite paths, showing alternative nozzle shapes.

[0021] FIG. 4 is a perspective view of one embodiment of the extruder housing.

[0022] FIG. 5 is a perspective view of one embodiment of the extruder housing with an attached means of curing.

[0023] FIG. 6 is a perspective view of a simple part demonstrating the locking path process.

[0024] FIG. 7 is a perspective view of a simple part composed of several locking paths.

[0025] FIG. 8 is a perspective view of a spiral shaped path.

[0026] FIG. 9 contains a perspective view of an extruder forming a tension path from an anchor, and an enlarged perspective view of an anchor, foot, and tension path.

[0027] FIG. 10 contains a perspective view and a section cut of an electronic device.

[0028] FIG. 11 contains a perspective view and a section cut of a boat hull.

DETAILED DESCRIPTION

[0029] Continuous Composite Three Dimensional Printing is a new method of additive manufacturing. This method enables the additive manufacturing of parts comprising two or more materials, and uses an alternate means of building parts with paths rather than slices.

[0030] Two or more materials are simultaneously incorporated into the construction of a part, creating a composite material path. The simplest embodiment of this method is the use of two materials. The primary material is a liquid curable material, and the secondary material is a solid strand.

[0031] The secondary material is fed through a nozzle at the same time that the primary material is extruded through the nozzle. The secondary material is fully surrounded by the primary material during the extrusion. Once the composite material is extruded it is cured becoming a solid composite path.

[0032] FIG. 1 shows eight example cross-sections of composite material paths created by the method. The primary material in each of these cross sections is a polymer resin. The secondary materials shown include carbon fiber, fiber optics, metallic wire, and rubber. Each cross-section has at least one secondary material entirely encased within the

primary material. The best mode for a composite material path, seen in FIG. 1, is carbon fiber encased within polymer resin 102.

[0033] The apparatus includes a reservoir for containing the primary material, and a means for delivering the primary material to the nozzle upon extrusion. Since primary materials are curable, the reservoir and means for delivery should be kept cool and dark as required to prevent curing before extrusion.

[0034] As show in FIG. 1, the best mode for the primary material is polymer resin, specifically a single component zero volatile organic compound resin, but any curable liquid material is included. Potential primary materials include epoxy resins, polyester resins, cationic epoxies, acrylated epoxies, urethanes, esters, thermoplastics, photopolymers, polyepoxides, metals, metal alloys, and more.

[0035] Interchangeable reservoirs and distribution tubes are included in the best mode, allowing the apparatus to support the use of multiple primary materials for the manufacturing of different parts.

[0036] Additionally, the primary material may be a combination of multiple materials. An example is a two-part epoxy. The two parts are combined in a mixing chamber prior to extrusion and extruded with the secondary material. In this instance, the apparatus will comprise two reservoirs for the two epoxies, and a mixing chamber connected to the extruder. The mixing chamber applies heat and pressure to the epoxy prior to extrusion.

[0037] The apparatus includes a spool or other means of storing the secondary material. The secondary material is a solid strand and flexible enough to be wound around a spool. It may be a single strand, a tow of several strands, a roving of several strands, or multiple strands woven together. The strands may be any shape, including circular, square, or flat.

[0038] FIG. 1 shows multiple examples of possible secondary materials. Included are carbon fiber, fiber optics, metal wire, and rubber. The strand may be any solid material. It may be a natural fiber produced by a plant, animal, or geological process. Example natural fibers include vegetable fibers such as cotton, hemp, jute, flax, ramie, rubber, sisal, and bagasse. Wood fibers include groundwood, thermomechanical pulp, and bleached or unbleached kraft or sulfite pulps. Animal fibers include silk, wool, fur and spidroins. Mineral fibers include chrysotile, amosite, crocidolite, tremolite, anthophyllite, and actinolite.

[0039] A six-thousand strand tow of carbon fiber with a diameter of approximately one millimeter is the best mode for the secondary material.

[0040] Secondary materials may also be composed of synthetic materials. Examples of synthetic materials include metals, metal alloys, aramid, carbon fibers, silicon carbides, fiberglass, petrochemicals, and polymers.

[0041] Pre-impregnating the secondary material is also envisioned. A secondary material is pre-pregged when it is saturated with another material. An example is pre-pregged carbon fiber. The carbon fiber is in the form of a weave, roving, or tow, and is saturated with liquid polymer resin. The polymer resin is only partially cured to allow for ease of handling. It is important to keep this partially cured secondary material cool and away from light to prevent premature curing prior to extrusion. FIG. 1 includes a cross-section of pre-pregged carbon fiber encased within polymer resin 101.

[0042] Multiple secondary materials may be present in a composite material path. The secondary material may be composed of multiple materials itself, as long as it maintains its strand form. Examples of multiple secondary materials are included in FIG. 1. Fiber optics encased in pre-pregged carbon fiber 103, metal wire encased within rubber encased within pre-pregged carbon fiber 105, metal wire encased within fiber optics encased within carbon fiber 106, rubber encased within pre-pregged carbon fiber 107, and metal wire encased within pre-pregged carbon fiber 108. Each of these examples of composite material is also encased in a primary material comprising polymer resin.

[0043] Another embodiment of the invention includes a secondary material that is hollow. The secondary material may be a strand that is in the form of a tube. A rubber tube encased within pre-pregged carbon fiber 107 is an example of a hollow secondary material. See FIG. 1. The hollow tube may serve as a conduit for another substance, or simply left vacant to reduce weight.

[0044] Referring now to the invention in more detail, in FIG. 4 there is shown a perspective view of said apparatus. Liquid hoses 1 are connected. These may dispense liquid from a compressed reservoir. The liquids may, or may not be a combination of epoxy resin and hardener, or any combination of plastics, liquids, or substrates that best suits the application at hand.

[0045] In more detail, still referring to the invention of FIG. 4, liquid may be passed through a thermal pressure chamber 2. Here, temperature and pressure may be controlled to allow for optimal setup, and/or hardening of the principal elements. A compressor and chambers with control valves may be used, along with coils of heating elements.

[0046] In more detail, still referring to the invention of FIG. 4 a variable connection 3 may allow for different applications of mixing vessels. Static disposable mixers may be used to mix the said elements. Other factors of material will be introduced, such as gasses and/or light to encourage the hardening.

[0047] It is envisioned that more than one secondary material may be desired during the manufacturing of a part. Multiple spools holding multiple secondary materials are envisioned.

[0048] In more detail, still referring to the invention of FIG. 4 a housing and/or loom 4 may be used to provide the variable fiber to the mixing head. Fibers of any kind may be used, spun, sewn, woven together or as a single thread. Flakes of fiber might also be introduced with the liquid as filler. The fiber is not limited to thread. It may be any combination of elements, and/or rare earths. The secondary materials may feed into the nozzle sequentially so that a part is comprised of a variety of composite material paths.

[0049] In more detail, still referring to the invention of FIG. 4, the liquid solution mixes in a variable sized reaction vessel that may or may not be disposable. The optimum mix, temperature, and reaction time may be achieved to produce a liquid ready to be hardened once combined with the fiber.

[0050] The apparatus includes an extruder housing, comprised of an extruder, a nozzle, a feeder, and a feeder flap. See FIG. 4. The extruder 401 is the location where the liquid primary material is collected before being extruded out of the nozzle. It may be any shape that facilitates the flow of primary material.

[0051] The nozzle is the actual point of extrusion of the composite material 402. See FIG. 4. The best mode for a

nozzle is circular, with a diameter of 2 mm. Any size and shape nozzle is envisioned, as necessitated by the part or economy of manufacture. The cross-sections shown in FIG. 1 demonstrate composite paths manufactured with a circular nozzle. FIG. 3 shows three examples of composite paths created with nozzles of alternative shapes, a triangular nozzle 301, a decagon 302, and a rectangle with a secondary material in a tape form 303. Any polygonal shaped nozzle is envisioned. The nozzle is interchangeable, allowing an apparatus to manufacture parts with different shaped paths, and different sized paths.

[0052] The extruder housing also contains a feeder 403, as shown in FIG. 4. The feeder directs the secondary material to the extruder. The feeder connects to the extruder prior to the nozzle, and feeds the secondary material into the extruder. The secondary material is extruded through the nozzle with the primary material, creating a composite material path.

[0053] The secondary material passes through a feeder flap. The feeder flap 404 is a one-way valve that allows the secondary material to enter the extruder, but prevents the primary material from entering the feeder.

[0054] The feeder may also have a motorized control dictating the feed rate. Certain embodiments create composite paths with tension, which will naturally pull the secondary material out through the nozzle. Other embodiments create paths without tension, and require a motor to control the feed rate. The motor synchronizes the feed rate with the extrusion rate, the rate at which the primary material is extruded.

[0055] Multiple feeders for multiple strands are envisioned, allowing the apparatus to easily alternate between secondary materials during the manufacturing of a part.

[0056] The composite material is extruded and then cured. The best mode cures the composite material immediately after extrusion, creating a solid path.

[0057] There are many potential means of curing, which are determined by the liquid primary material. Possible means of curing include light, heat, and chemical. Ultraviolet light on photosensitive polymer resin is the best mode. FIG. 5 shows an apparatus with a means of curing attached to the extruder housing. This figure shows an ultraviolet light 501 attached and aimed at the point of extrusion. Other methods of curing by light include microwave, electron beam, laser, and infrared. Additionally, some primary materials may cure by exposure to natural light.

[0058] The means for curing may also be chemical. If a two-part epoxy is used as the primary material, the composite path will cure without any additional means. Other embodiments include the introduction of a catalyst to the primary material in the extruder. The catalyst begins the curing process, and the path hardens soon after extrusion. The introduction of heat to a composite path also may aid the curing process.

[0059] The apparatus may include the means for curing, as in FIG. 5, or in other embodiments the means for curing may be external. An example may be a hand held ultraviolet light, or an oven within which to place the part.

[0060] Some embodiments may include multiple means for curing. An example might be multiple ultraviolet lights placed around the entire extruder to ensure curing of a path created at any angle. An alternative embodiment includes an ultraviolet light with directional control. It may be angled

appropriately during the extrusion of a path to ensure curing through tight angles and complicated paths.

[0061] When a composite material path is complete, the path is cut at the point of extrusion. Any means of cutting will suffice, including a hand held blade. Some embodiments of the apparatus include a means for cutting. Possible means include mechanical blades or lasers.

[0062] The best mode of the apparatus will have two means of cutting, one for the secondary material at some point prior to the feeder flap, and one just after the nozzle. Embodiments with a means of cutting the secondary material afford increased functionality. An alternative secondary material may seamlessly feed into the path, or the path may continue with only the primary material.

[0063] A part may be constructed of one continuous path, or may be formed from several paths. FIG. 2 shows a sectional view of a simple part with multiple paths. When constructing a part, each path is extruded sequentially. The first path is extruded and cut, and then another path is extruded and cut, connecting to some portion of the previous path. Additional paths are extruded until the entire part is formed.

[0064] When constructing a part, some portions may be created with composite material, and some portions may be created with only primary material. The apparatus has the option of creating paths with the composite material or with only the primary material. When a composite path is complete, it is cut. The next path in the creation of the part may be composite material, or may be of only extruded primary material.

[0065] This embodiment of the method is useful when the secondary material is needed only in small quantities. This embodiment of the method is also useful when the manufacturer requires only the exterior paths of a part to contain composite material, or alternatively, when the exterior paths are solely primary material intended to finish the surface.

[0066] The apparatus may be a handheld device. A simple apparatus with manual maneuvering and controls may be the optimal embodiment for certain repairs of existing parts or machinery.

[0067] The best mode embodiment is an automated mechanical apparatus. This embodiment comprises a means of numerical control for the location of the nozzle, and thus the extrusion point. The best mode for numerical control is a robotic arm, but other means of control, including a gantry system, are envisioned.

[0068] Using a computer independent of the apparatus, a three-dimensional digital model of the desired part is created with a computer-aided design (CAD) program. The model is stored as a digital file.

[0069] The model file is then delivered to a software program designed to convert the model into paths. This program is called the pathing software, and translates the model into G-code. G-code is a numerical control programming language. It organizes a sequence of paths along with other coordinated controls in a digital file. A G-code file extension may be .mpt, .mpf, and .nc, among others. Some of the data stored in G-code for a particular part includes: the starting point, coordinates along a path, and endpoint for each path; the size of the part; which paths are composite materials; which paths are primary material only; where to cut a path or secondary material; the feed rate; the extrusion rate; and controls for the means for curing.

[0070] When the pathing software translates a model into G-code, it takes various factors into consideration. Depending on the needs of the manufacturer, certain parameters may influence the pathing sequence. Speed of manufacture, the need for continuous paths of composite material, the need for paths of primary material, the differences in the interior and exterior of a part, the desired interior matrix, and weight of the part are examples.

[0071] The G-code stores all of the information listed above, and in a coordinated matter. For example, the extrusion rate is synchronized to the feed rate, ensuring a uniform ratio of primary to secondary material throughout the length of a path. Another example is the coordination of the extrusion rate and feed rate with the start and end of a path. Both are stopped during the time the robotic arm is repositioning the nozzle to the next path starting point.

[0072] An external computer is linked to the apparatus through a means of data connection. An example may be a universal serial bus. The G-code file is transferred to the apparatus and stored in an electronic storage.

[0073] The apparatus is comprised of computer hardware and software necessary for the translation of G-code into extruded paths. Hardware and electronic components include: electronic data storage; microprocessor; random access memory; an external data connection; a digital display on the apparatus for a message log; motors for pumps, vacuum, compressor, numerical control system, and means for curing; input and output wiring to motors and lights; and connection to a power source.

[0074] Software components stored in the electronic storage and run on the processor include a primary material processing unit, a secondary material processing unit, a path termination processing unit, an energy curing processing unit, and a numerical control processing unit.

[0075] The primary material processing unit controls the functions associated with the primary material. This includes the extrusion rate, which is managed by a pump connected to a hose between the primary material reservoir and the extruder. Additionally, the primary material processing unit may control alterations to the nozzle. In alternative embodiments, the apparatus may possess multiple nozzles or an adjustable nozzle. For these embodiments, the primary material processing unit also controls a means of switching nozzles, or adjusting the diameter or shape of an adjustable nozzle.

[0076] The secondary material processing unit controls the functions associated with the secondary material. This includes starting and stopping the feeding of the secondary material, as well as adjusting the feed rate during the extrusion of a path. In alternative embodiments with multiple spools containing secondary materials, this processing unit controls the means for switching between secondary materials during the manufacturing of a part.

[0077] The path termination processing unit controls the cutting of paths. This includes the cutting of the composite material at the end of a path, the cutting of the secondary material when a path is converting to a primary material only, and the cutting of the secondary material in order to alternate to another secondary material.

[0078] The energy curing processing unit controls the means for curing. In the best mode, the apparatus possesses an ultraviolet light aimed at the path just after the point of extrusion. During extrusion, the light will turn on and off at

the beginning and ending of paths, respectively. For certain parts, this processing unit may also administer an intermediate light intensity.

[0079] Alternative embodiments may include the controlling of several means for curing, possibly several ultraviolet lights around the point of extrusion, curing the path from multiple angles. Another alternative embodiment includes a means for curing with an adjustable direction. The ultraviolet light may be mounted on an additional numerical control system affording constantly adjusted angles, which target the path as it trails away from the nozzle in varying directions.

[0080] The energy curing processing unit also controls methods that utilize an alternative means of curing. The processing unit will control the distribution of a chemical catalyst, the activation of a heat source, or the administration of any of the alternative means for curing listed above.

[0081] The numerical control processing unit controls the means of locating the point of extrusion. This processing unit maneuvers the nozzle to the starting point of the first path, the origin, and extrudes all paths sequentially in relation to that point. The means for numerical control is adjusted accordingly with the sequence of paths, taking into consideration the nozzle's angle of approach in relation to the part.

[0082] Prior to manufacturing a part, the manufacturer designates an origin. The origin may be any point on any surface suitable for anchoring the part during manufacturing. This point of contact is called an anchor. Some parts may require multiple anchor points to support a part during manufacturing.

[0083] Once the origin is located, the numerical control processing unit positions the nozzle so that the point of extrusion is at the origin. The primary material processing unit pumps the primary material from its reservoir through a hose, filling the extruder housing with the primary material. Simultaneously, the secondary material processing unit feeds the secondary material to the nozzle. The energy curing processing unit activates the ultraviolet light, and the composite material is extruded as the numerical control maneuvers along the first path.

[0084] When the first path reaches its endpoint, the path termination processing unit cuts the path, and the numerical control positions the nozzle for the start of the next path in the sequence according to the G-code. Paths are continuously extruded and cured until the sequence and the part is complete.

[0085] Alternative embodiments include another software component, a feedback processing unit. This processing unit gathers feedback from multiple sensors concerning the status of the apparatus and the currently extruding path. Sensors may include a visual input device, such as a video camera or infrared scanner, a thermometer, a pressure sensor, and input from the feeder motor.

[0086] During the extrusion of a path, the visual input device monitors the point of extrusion and the existing paths, relaying that information to the feedback processing unit. If the point of extrusion is misaligned relative to the existing part or the pathing coordinates, this processing unit will realign the extruder or halt the extrusion.

[0087] Similarly, information regarding temperature of the composite material, the motors, and the electronics is delivered to this processing unit. Also, information about the rate of extrusion, and pressure in all pumps and hoses is delivered to processing unit. If any feedback is outside designated

parameters, the processing unit adjusts the system accordingly to ensure the correct extrusion of the current path. If feedback continues to lie outside designated parameters, extrusion is halted.

[0088] An alternative embodiment of the method calls for the curing of certain portions of the composite path at a later time. The energy curing processing unit will cure portions of the path upon extrusion, but leave some portions of the path uncured, or partially cured. The uncured portions are physically manipulated to interact with a cured portion of the part, creating what are called "locking paths".

[0089] The manipulation of the uncured portion of the path may be by a hand-held device. The best mode is an apparatus with a robotic arm on the extruder housing, which has an appendage suitable for manipulating the uncured portion. An alternative embodiment may have an appendage on another type of numerical control, or simply an appendage connected directly to the extruder housing. Another software component, the spatial manipulation processing unit, controls the movements of the appendage in coordination with the other processes.

[0090] The uncured portions of the path are adjusted so they interact with a cured portion. For example, the uncured portion may be wrapped around a cured portion. When the uncured portions are adjusted to the desired location, they are cured and hardened into their new position. The ability to intertwine the paths increases the strength of the part.

[0091] FIG. 6 shows an example part and the steps associated with creating locking paths. The drawing shows a continuous composite path extruded in a complex pattern. On this part, there are six u-turns, or loops, which were initially left uncured upon extrusion. The first loop **601** is uncured and in its original extruded form. The second loop **602** is uncured and in the process of being manipulated so it bends around a cured portion of the part. The third loop **603** is fully bent around a cured portion of the part.

[0092] The three loops on the anterior side of the part in FIG. 6 all went through the process demonstrated by **601** through **603**. When the loops are fully bent around the respective cured portions of the part, they are cured and become locking paths.

[0093] FIG. 7 shows a part with several iterations of the same locking paths in FIG. 6. When manufacturing this part, each loop is bent and cured intermittently as each layer of locking paths are extruded.

[0094] The method and apparatus described above affords the opportunity to extrude paths not previously available. The inclusion of a secondary material adds structural stability to the composite path, allowing extrusion into space opposed to gravity, as demonstrated in FIG. 8 and FIG. 9.

[0095] FIG. 8 shows a path extruded in a spiral form. The secondary material supports the path while it is being extruded, giving the designer and manufacturer more freedom in creating the part. Slicing methods of additive manufacturing by extrusion require a gravitational base beneath each layer. To extrude a spiral shaped part by slicing technique, additional material supporting each section of the spiral is required. This constricts the designer, requires more material to print a part, and increases the time of manufacture.

[0096] FIG. 9 shows a tension path **901**. The composite path is first extruded onto an anchor **903**. Any surface or point may provide an anchor point. In FIG. 9, the anchor is

a vertical plane. The origin of the path adheres to the anchor, allowing the extruder to pull on the secondary material during the extrusion.

[0097] The addition of a secondary material allows the path to extend into space opposed to gravity, and is useful in the extrusion of paths requiring long spans. Additionally, tension forces within a finished part provide structural strength.

[0098] The initial contact between the proposed part and the anchor must provide enough adhesion to support the tension force desired. Paths of greater tension may require an additional length of path extruded upon the anchor, to provide more adhesion. FIG. 9 shows a short length of path 902 extruded upon the anchor prior to extending horizontally away.

[0099] This initial length, called a foot, may or may not be a portion of the finished part. In situations where the foot is simply functional during manufacturing, it is removed after the extrusion process.

[0100] FIGS. 10 and 11 show two products, a small electronic device and a boat hull, created by the method and apparatus. These two figures demonstrate a wide range of applications for the method and apparatus described above.

[0101] FIG. 10 is a small electronic device with a credit card reader and a touch surface 1001. The main body of the device is comprised of composite paths of carbon fiber encased within polymer resin, as represented by the pattern 1002. Cross-sections of the paths comprising the body are enlarged to enhance visibility 1003. The use of a carbon fiber and polymer resin composite creates a strong and light-weight body.

[0102] The circular surface on top of the device is comprised of composite paths of metal wire encased within fiber optics encased within polymer resin, as represented by the pattern 1004. Cross-sections of the paths comprising the touch surface are enlarged to enhance visibility 1005.

[0103] Metal wires in the composite paths enable parts to have electronic capabilities. In FIG. 10, the metal wires form a touch sensitive surface. The fiber optics in the composite paths enable the surface to illuminate. For example, when a user interacts with the surface by touching it, the fiber optics light up providing visual feedback regarding the interaction.

[0104] FIG. 11 is a boat hull 1101, comprised of composite paths of hollow rubber tubing encased within carbon fiber encased within polymer resin, as represented by the pattern 1102. Cross-sections of the paths comprising the hull are enlarged to enhance visibility 1103. The use of carbon fiber and polymer resin in the composite paths provide strength and lightness. The hollow rubber tubing in the composite paths create air pockets throughout, increasing the lightness and buoyancy of the hull.

What is claimed is:

1. An apparatus for additively manufacturing a three-dimensional object, comprising:

an extruder configured to mix a first epoxy part with a second epoxy part to create an epoxy, and to discharge a continuous strand material at least partially coated in the epoxy;

an automated mechanical apparatus connected to the extruder; and

at least one processing unit programmed to control the automated mechanical apparatus to move the extruder

so as to cause the continuous strand material to be discharged from the extruder in a three-dimensional shape.

2. The apparatus of claim 1, wherein:

the first epoxy part is a resin; and

the second epoxy part is at least one of a catalyst and a hardener.

3. The apparatus of claim 1, further including a plurality of liquid hoses configured to dispense the first and second epoxy parts into the extruder.

4. The apparatus of claim 3, further including at least one reservoir from which the liquid hoses dispense the first and second epoxy parts.

5. The apparatus of claim 1, further including a mixing chamber configured to mix the first and second epoxy parts together.

6. The apparatus of claim 5, wherein the mixing chamber is configured to apply at least one of heat and pressure to the epoxy prior to discharge.

7. The apparatus of claim 1, further including:

a mixer; and

a variable connection allowing for connection of the mixer to the extruder.

8. The apparatus of claim 7, wherein the mixer is disposable.

9. The apparatus of claim 7, wherein the mixer is static.

10. The apparatus of claim 1, wherein the extruder is configured to introduce a gas to encourage hardening of the epoxy.

11. The apparatus of claim 1, further including a means for curing the epoxy after discharge from the extruder.

12. The apparatus of claim 11, wherein the means for curing the epoxy is a UV light.

13. The apparatus of claim 11, wherein the means for curing the epoxy is heat.

14. The apparatus of claim 1, further including a plurality of spools configured to introduce a plurality of different continuous strand materials into the extruder.

15. The apparatus of claim 14, further including a loom configured to provide the plurality of different continuous strand materials from the plurality of spools into the extruder sequentially.

16. An apparatus for additively manufacturing a three-dimensional object, comprising:

a mixing chamber configured to receive a resin and at least one of a catalyst and hardener;

a mixer configured to mix the resin and the at least one of the catalyst and the hardener to create an epoxy;

a nozzle configured to discharge a continuous strand material at least partially coated in the epoxy; and

an automated mechanical apparatus connected to the nozzle; and

at least one processing unit programmed to control the automated mechanical apparatus to move the nozzle so as to cause the continuous strand material to be discharged from the nozzle in a three-dimensional shape.

17. The apparatus of claim 16, further including a means for curing the epoxy after discharge from the nozzle.

18. A head for an additive manufacturing system, comprising:

a mixing chamber configured to receive a resin and at least one of a catalyst and a hardener;

a mixer configured to mix the resin and the at least one of the catalyst and the hardener to create an epoxy; and

a nozzle configured to discharge a continuous strand material at least partially coated in the epoxy.

19. The head of claim **18**, wherein the mixer is at least one of static and disposable.

20. The head of claim **18**, further including a means for curing the epoxy after discharge from the nozzle.

* * * * *