



US 20240176209A1

(19) **United States**

(12) **Patent Application Publication**

Miller et al.

(10) **Pub. No.: US 2024/0176209 A1**

(43) **Pub. Date: May 30, 2024**

(54) **CAMERA WITH FOLDED OPTICS HAVING MOVEABLE LENS**

(71) Applicant: **Apple Inc.**, Cupertino, CA (US)

(72) Inventors: **Scott W. Miller**, Los Gatos, CA (US); **Alfred N. Mireault**, Cambridge, MA (US); **Brad V. Johnson**, Santa Clara, CA (US); **Nicholas D. Smyth**, San Jose, CA (US); **Rummel R. Adriano**, Milpitas, CA (US); **Shashank Sharma**, San Francisco, CA (US); **Steven Webster**, Singapore (SG)

(73) Assignee: **Apple Inc.**, Cupertino, CA (US)

(21) Appl. No.: **18/433,303**

(22) Filed: **Feb. 5, 2024**

**Related U.S. Application Data**

(63) Continuation of application No. 17/221,620, filed on Apr. 2, 2021, now Pat. No. 11,934,090, which is a continuation of application No. 16/244,030, filed on Jan. 9, 2019, now Pat. No. 10,969,652.

(60) Provisional application No. 62/615,824, filed on Jan. 10, 2018.

**Publication Classification**

(51) **Int. Cl.**  
**G03B 5/04** (2006.01)  
**G03B 3/10** (2006.01)  
**G03B 5/00** (2006.01)

**G03B 13/36** (2006.01)  
**G03B 17/17** (2006.01)  
**H02K 41/035** (2006.01)  
**H04M 1/02** (2006.01)  
**H04N 23/54** (2006.01)  
**H04N 23/55** (2006.01)  
**H04N 23/57** (2006.01)  
**H04N 23/67** (2006.01)  
**H04N 23/68** (2006.01)

(52) **U.S. Cl.**  
CPC ..... **G03B 5/04** (2013.01); **G03B 3/10** (2013.01); **G03B 5/00** (2013.01); **G03B 13/36** (2013.01); **G03B 17/17** (2013.01); **H02K 41/0356** (2013.01); **H04N 23/54** (2023.01); **H04N 23/55** (2023.01); **H04N 23/57** (2023.01); **H04N 23/67** (2023.01); **H04N 23/687** (2023.01); **G03B 2205/0015** (2013.01); **G03B 2205/0069** (2013.01); **H02K 2201/18** (2013.01); **H04M 1/0264** (2013.01)

(57) **ABSTRACT**

Various embodiments include a camera with folded optics and lens shifting capabilities. Some embodiments include voice coil motor (VCM) actuator arrangements to provide autofocus (AF) and/or optical image stabilization (OIS) movement. Some embodiments include suspension arrangements. The suspension arrangements may include leaf springs attached to a carrier structure for the lens.

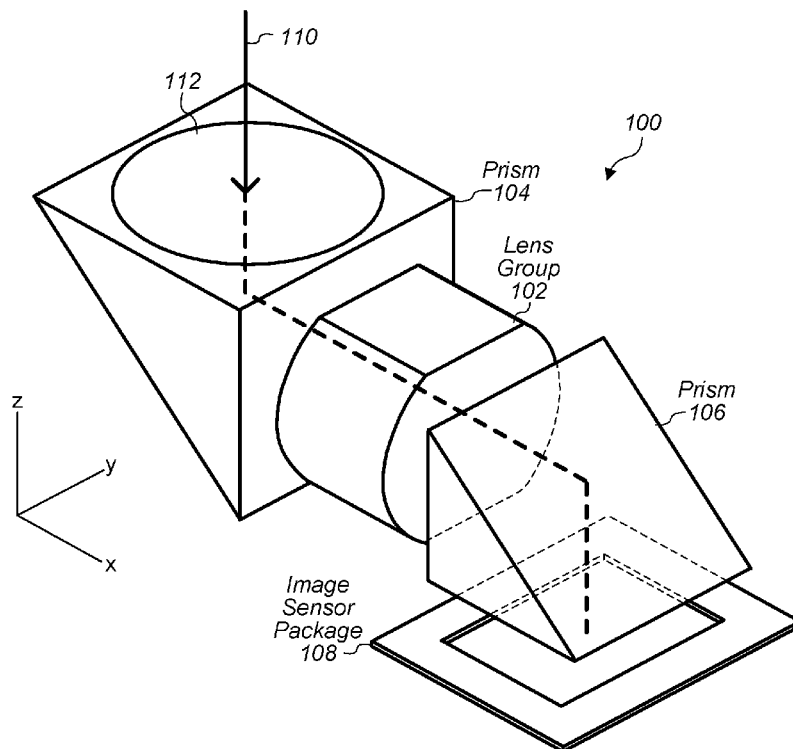

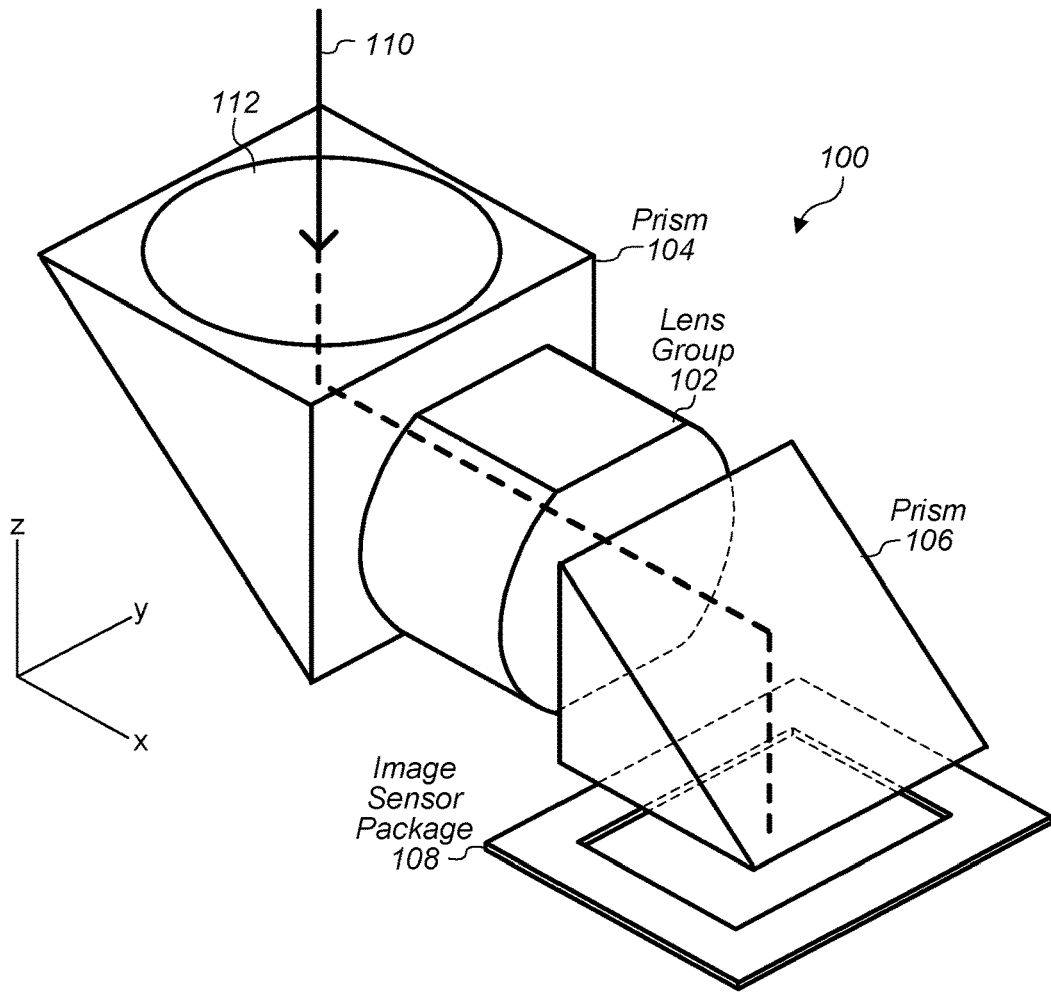

FIG. 1

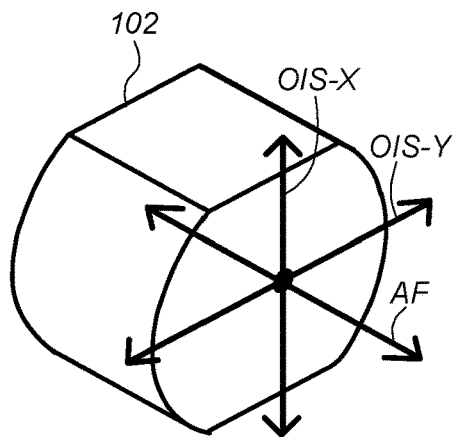

FIG. 2

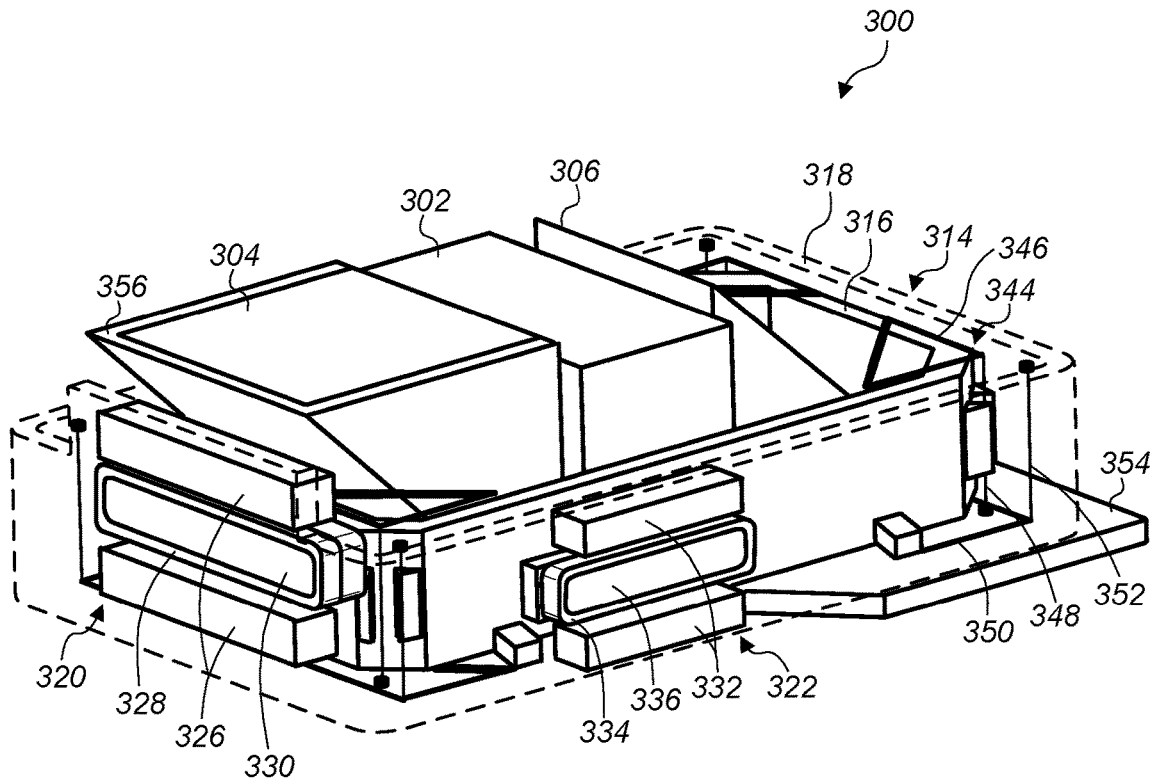

FIG. 3

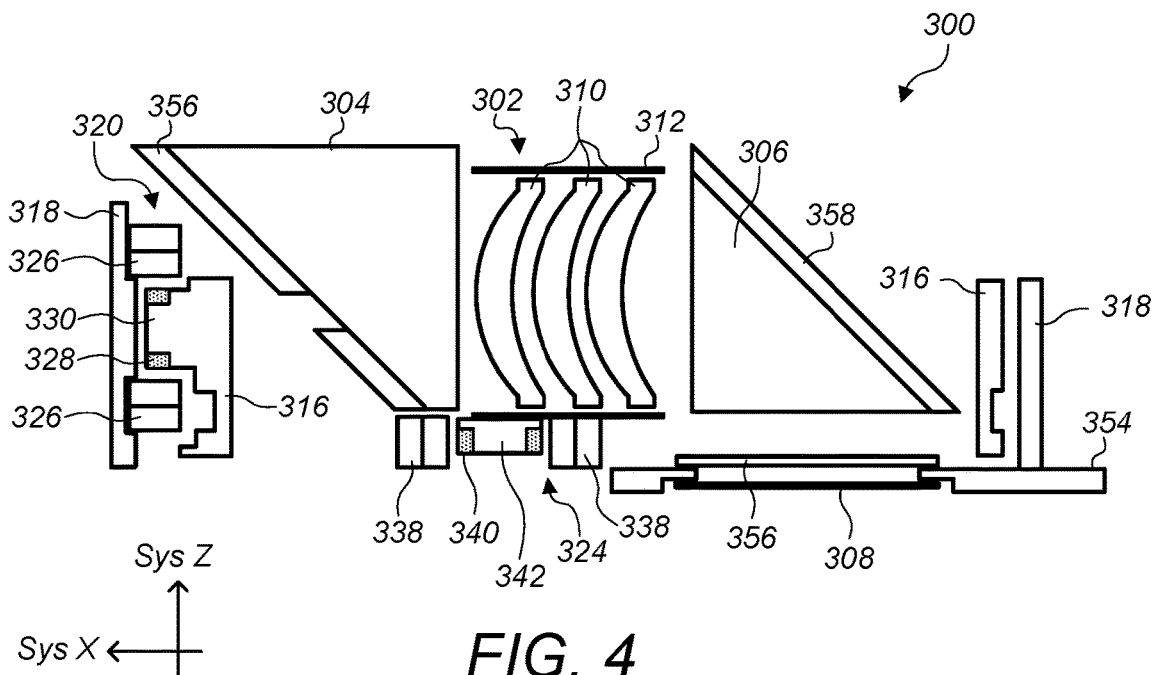

FIG. 4

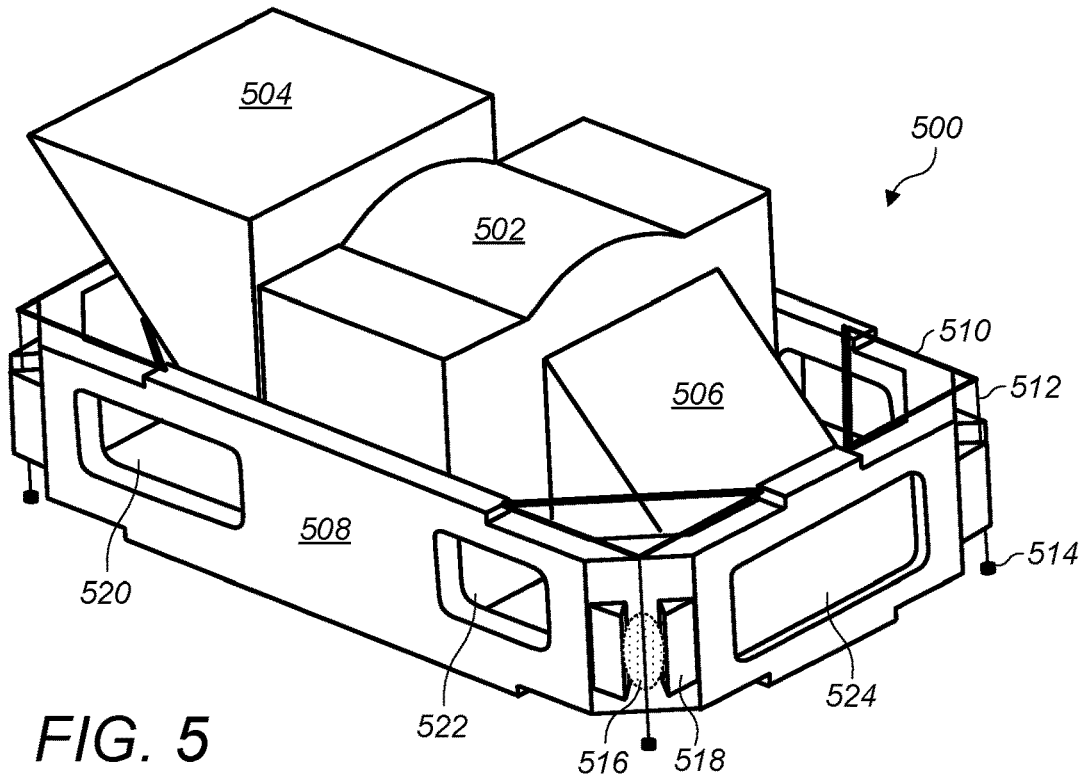

FIG. 5

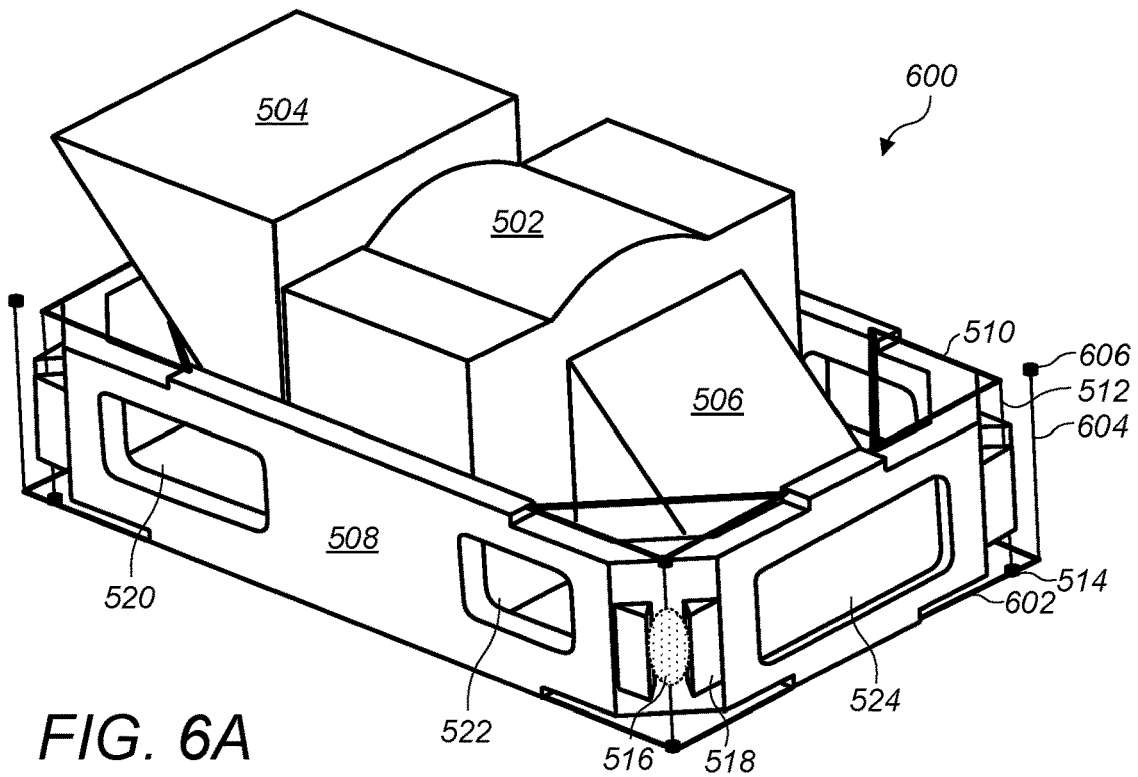

FIG. 6A

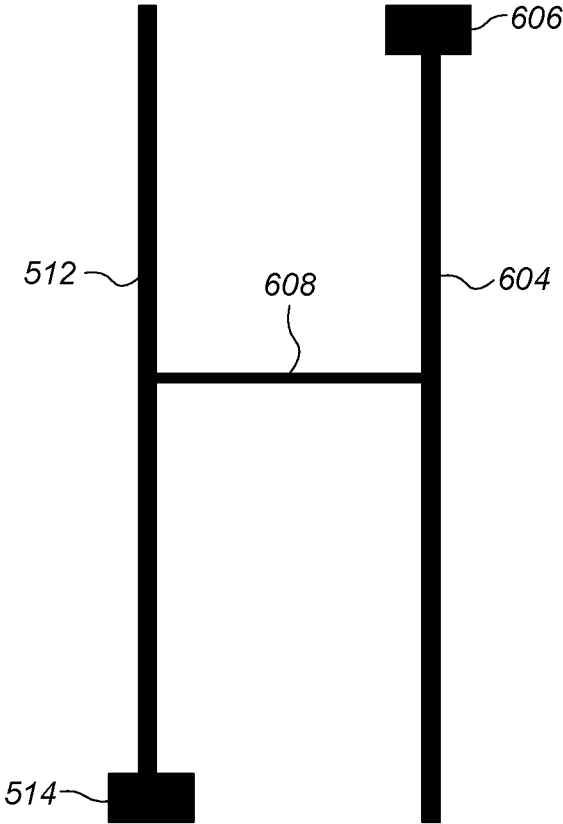

FIG. 6B

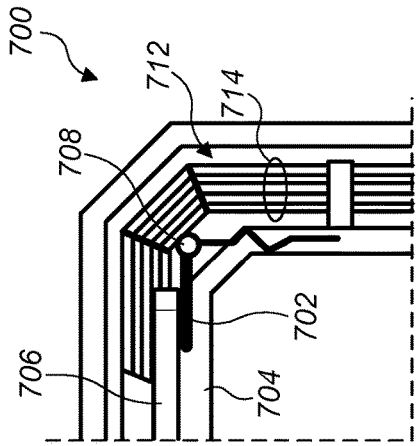

FIG. 7B

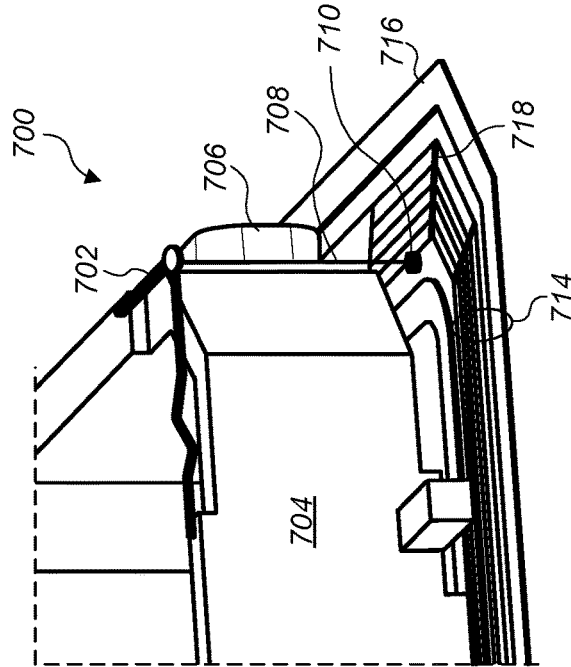

FIG. 7C

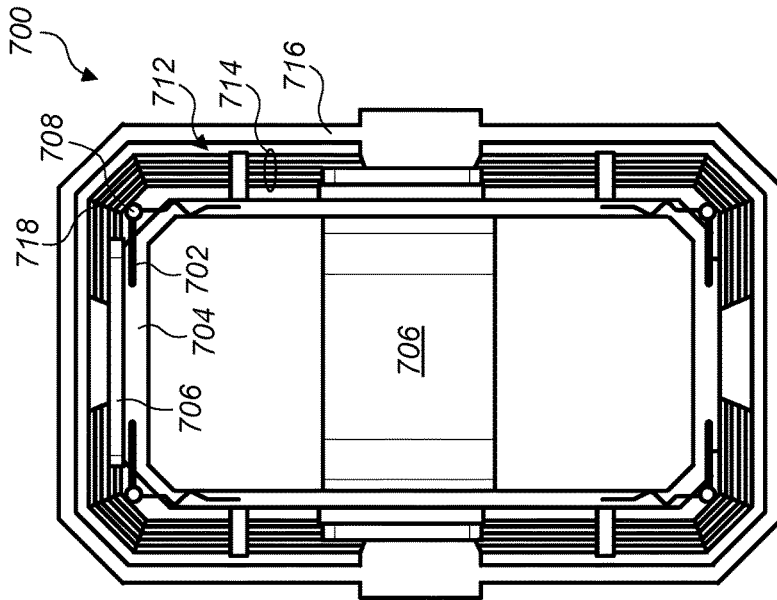

FIG. 7A

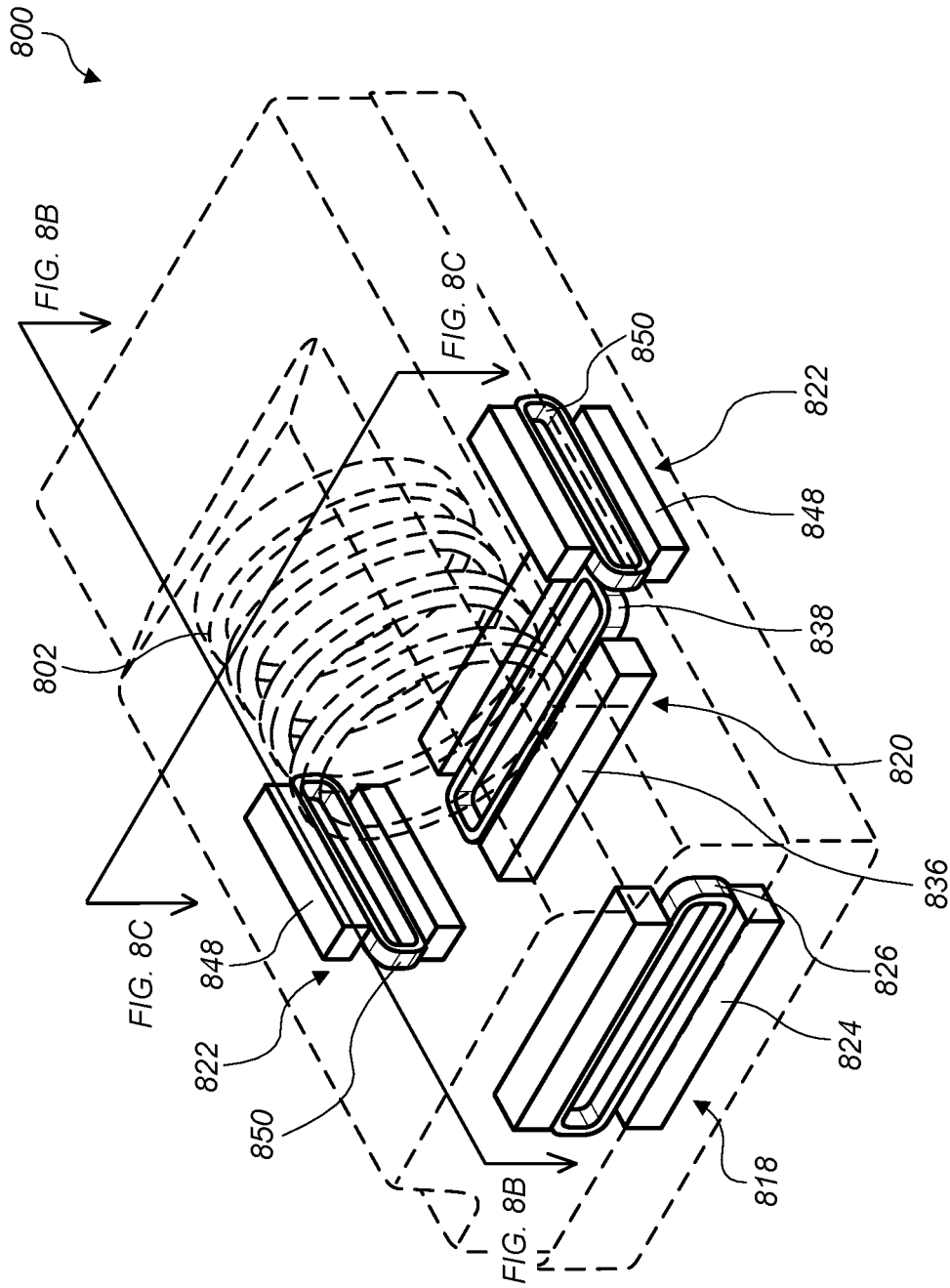

FIG. 8A

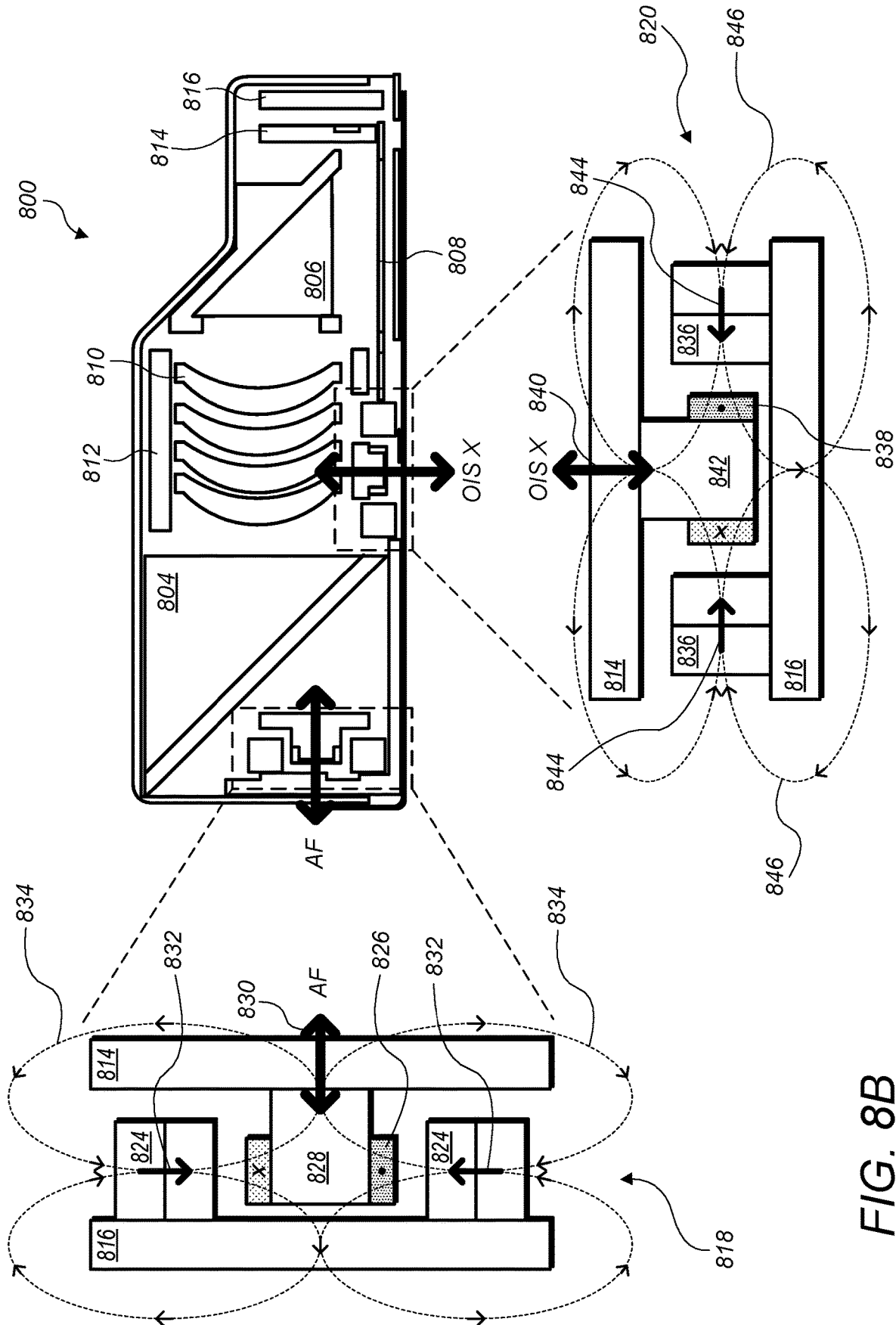

FIG. 8B



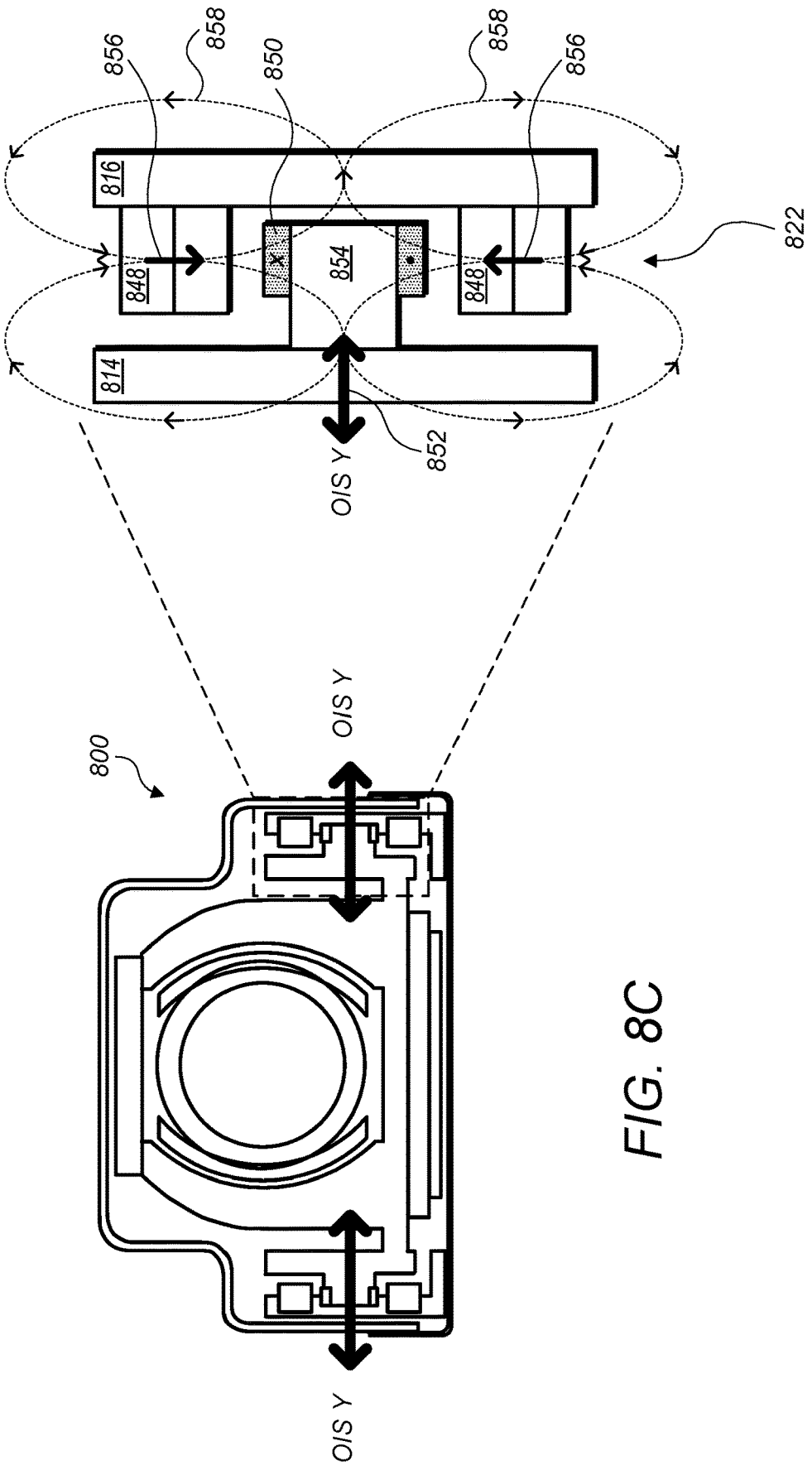

FIG. 8C

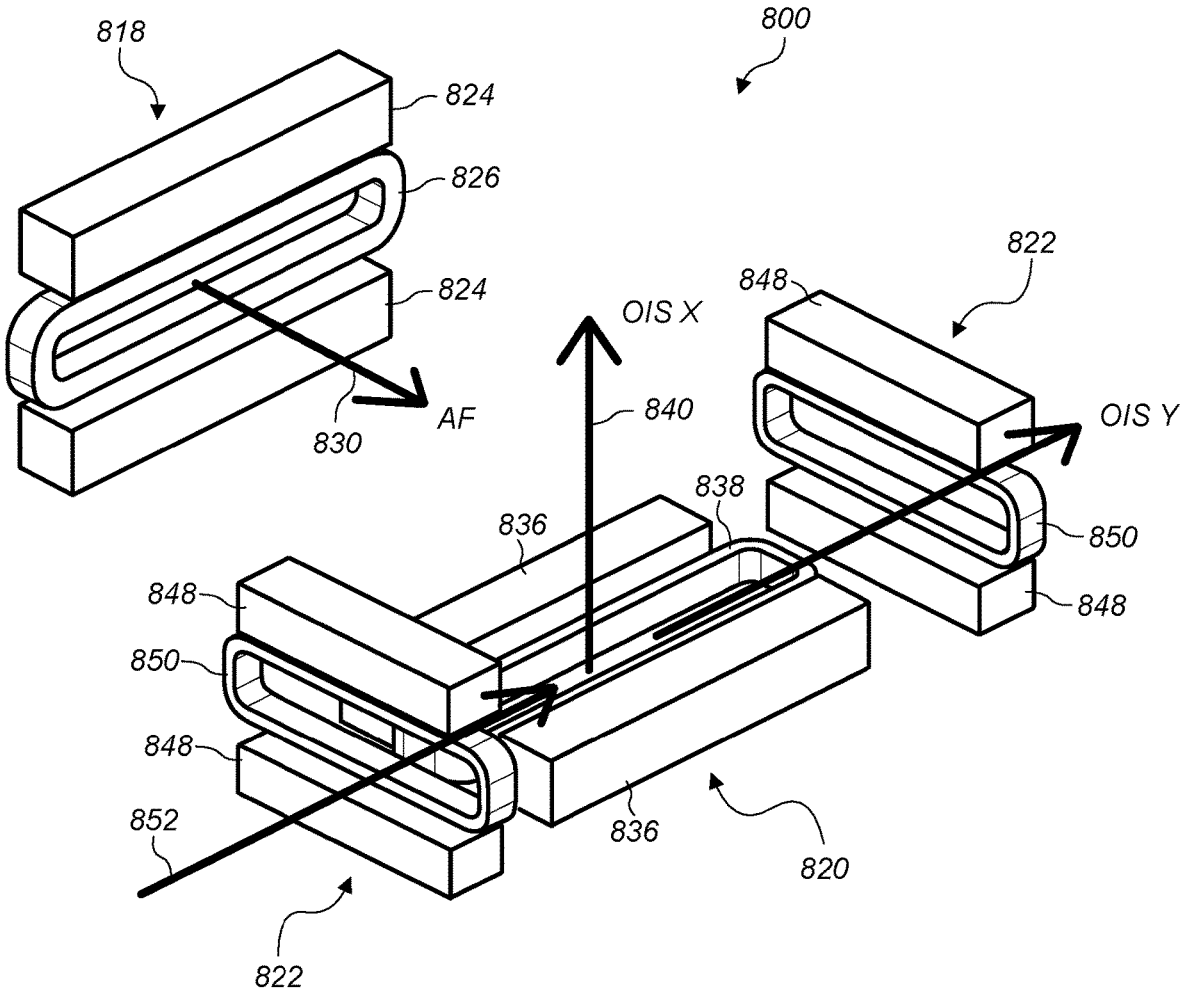

FIG. 8D

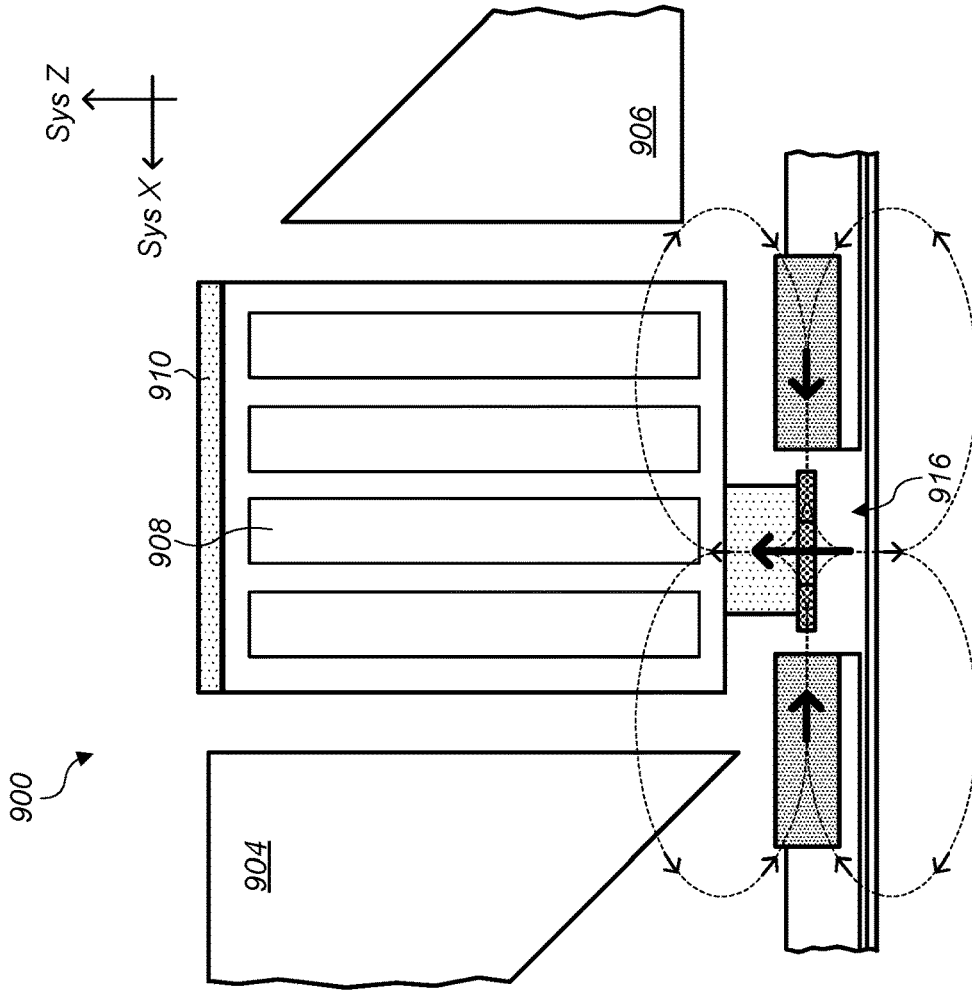

FIG. 9C

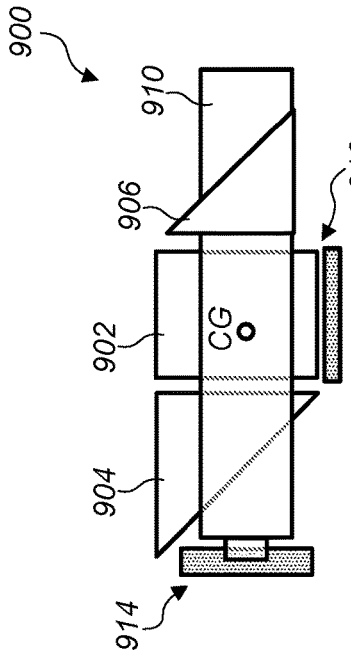

FIG. 9A

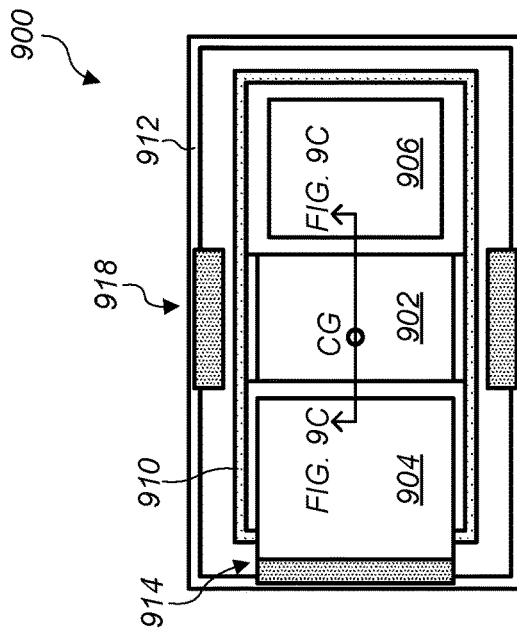

FIG. 9B

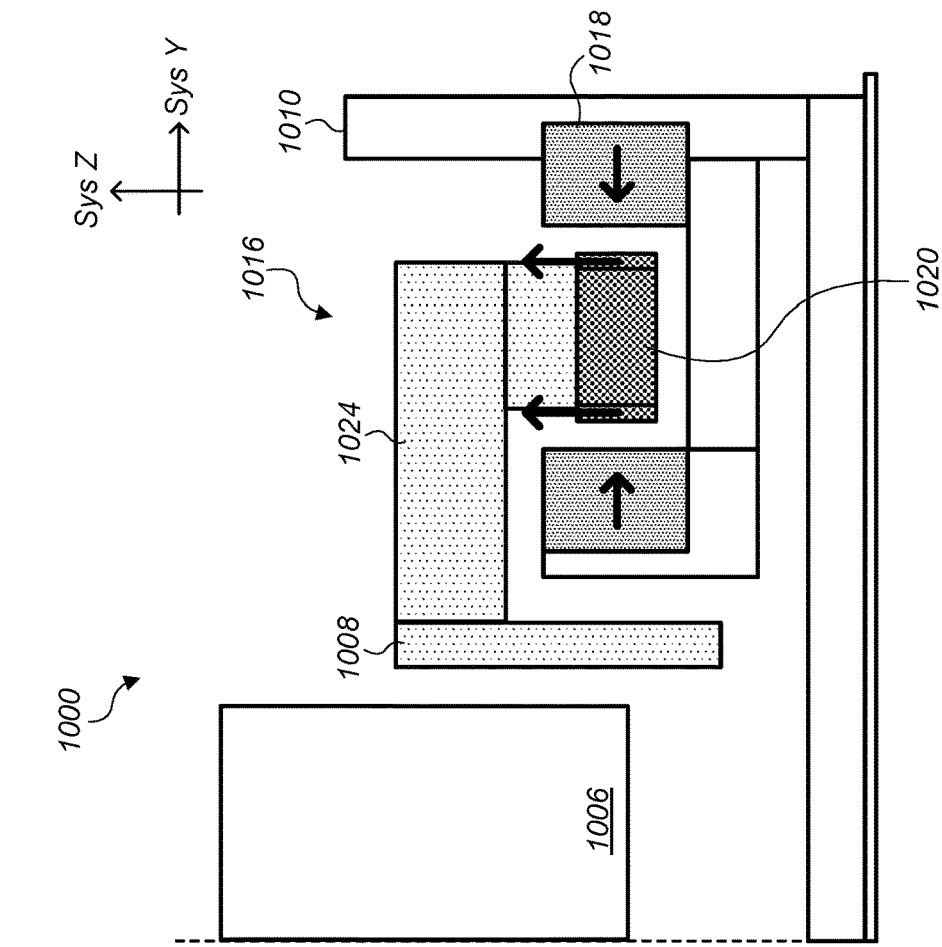

FIG. 10C

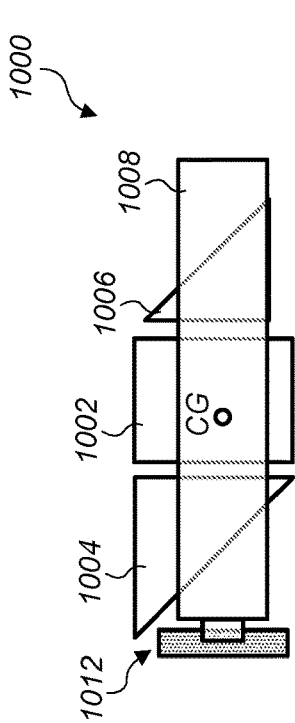

FIG. 10A

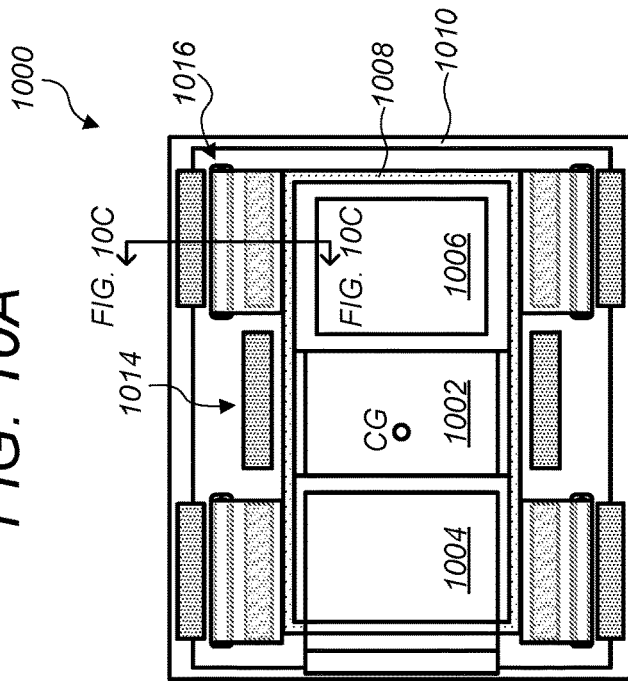

FIG. 10B

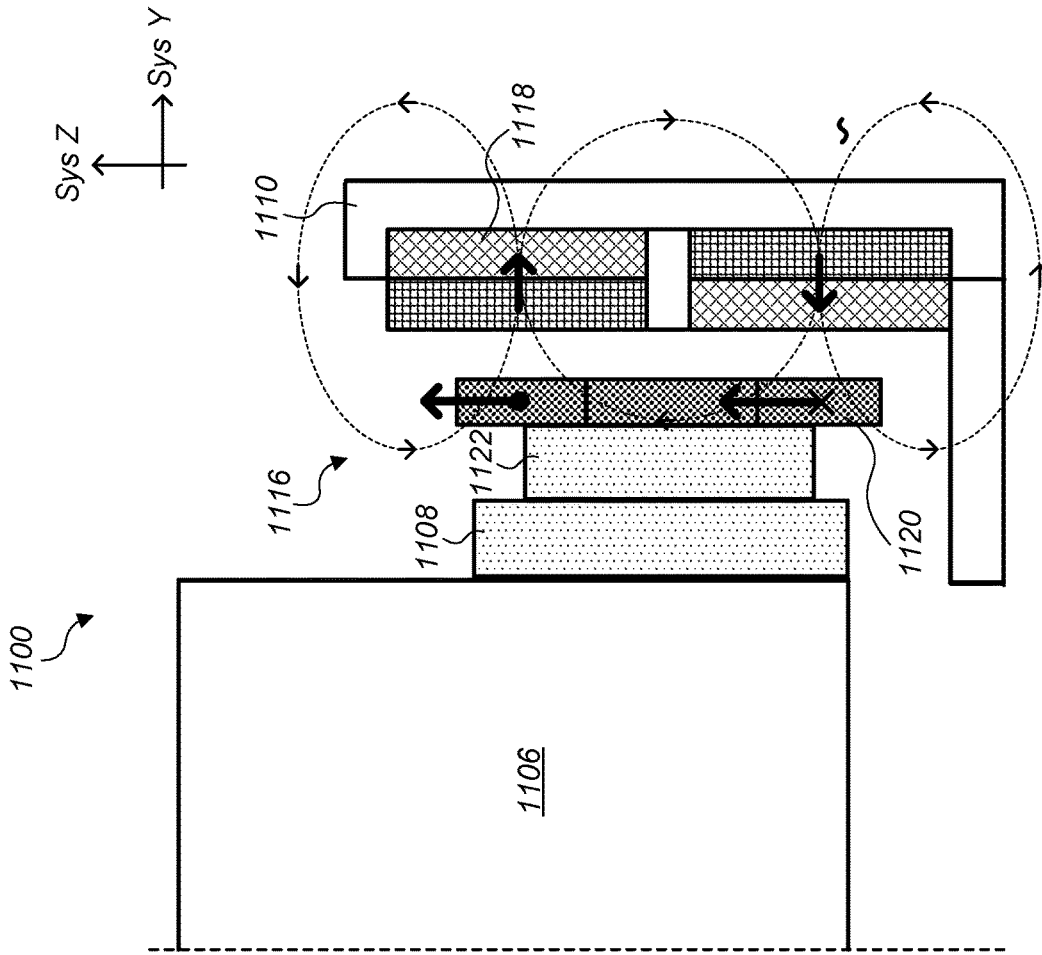

FIG. 11C

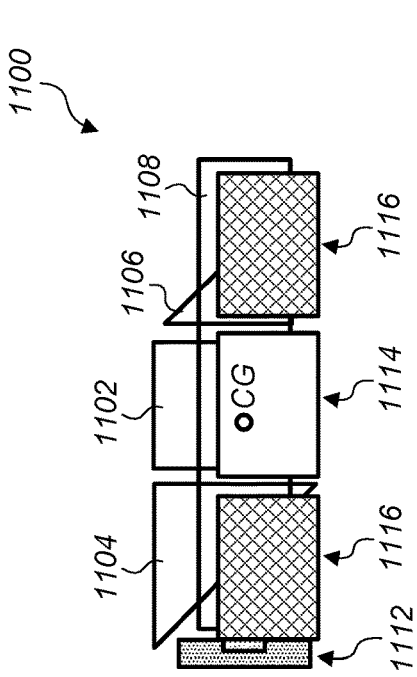

FIG. 11A

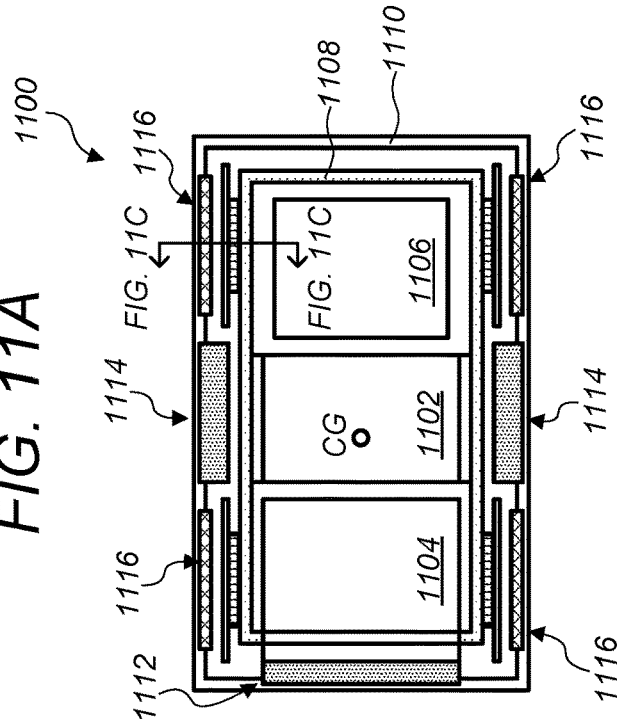

FIG. 11B

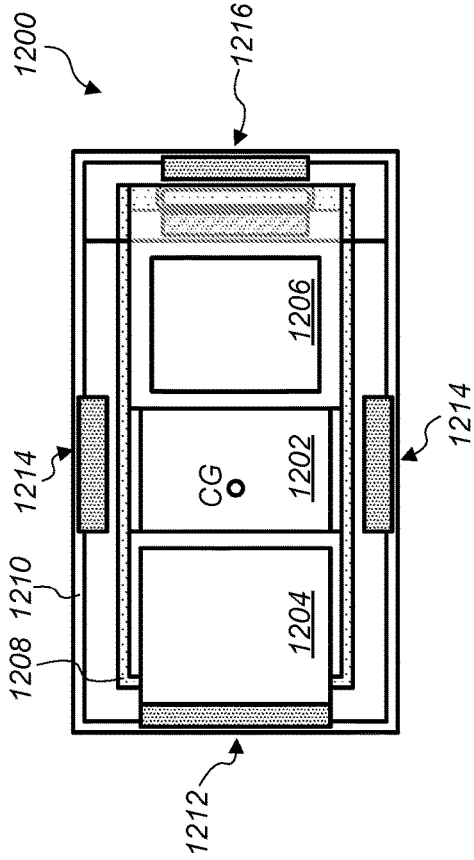

FIG. 12A

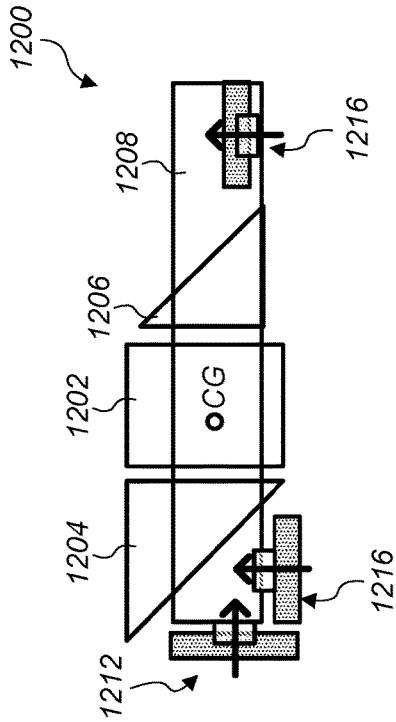

FIG. 12B

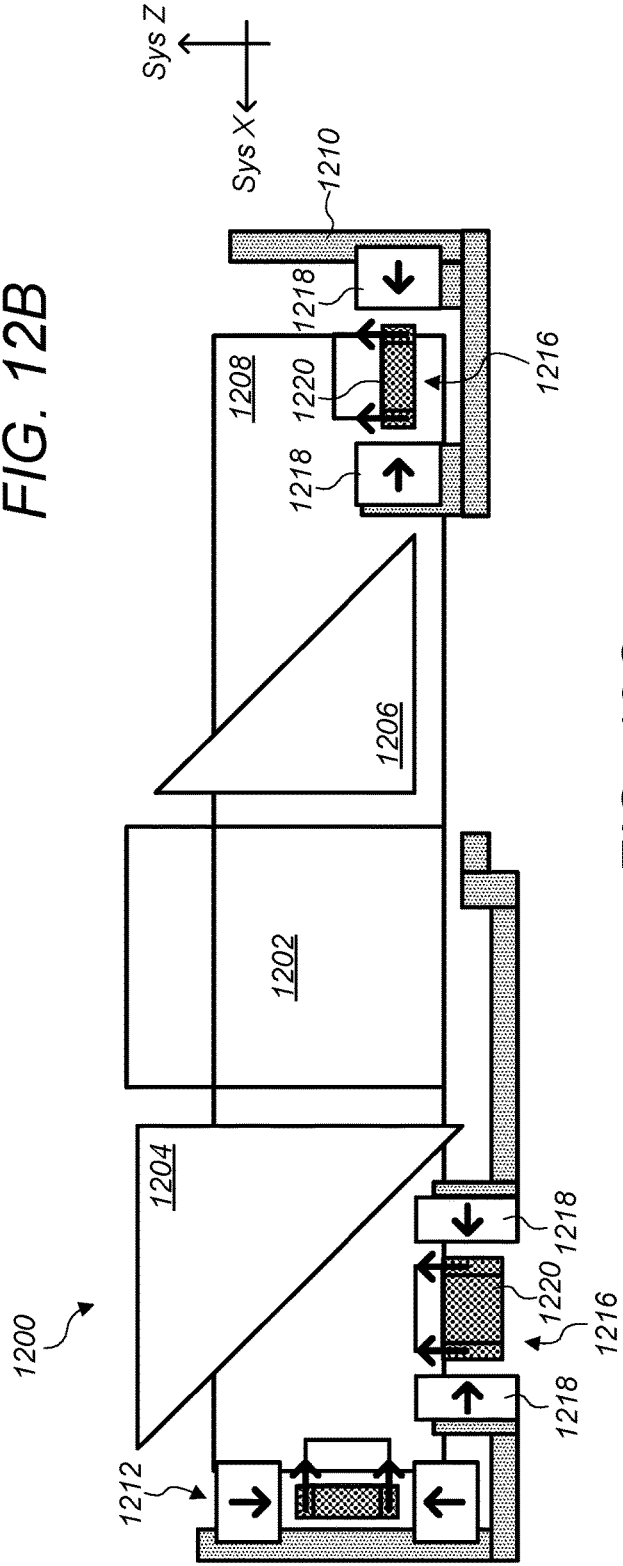

FIG. 12C

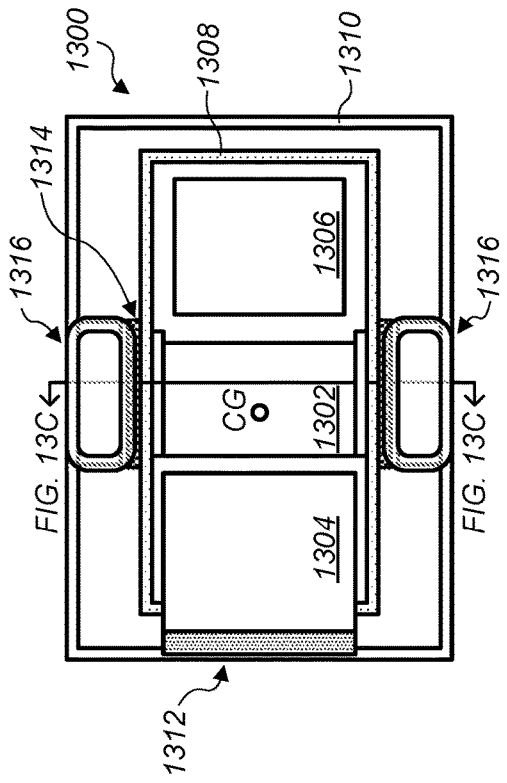

FIG. 13A

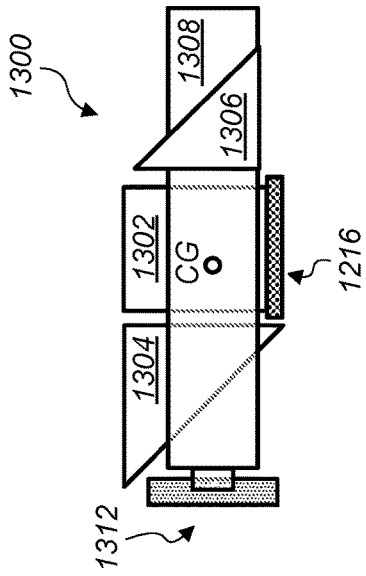

FIG. 13B

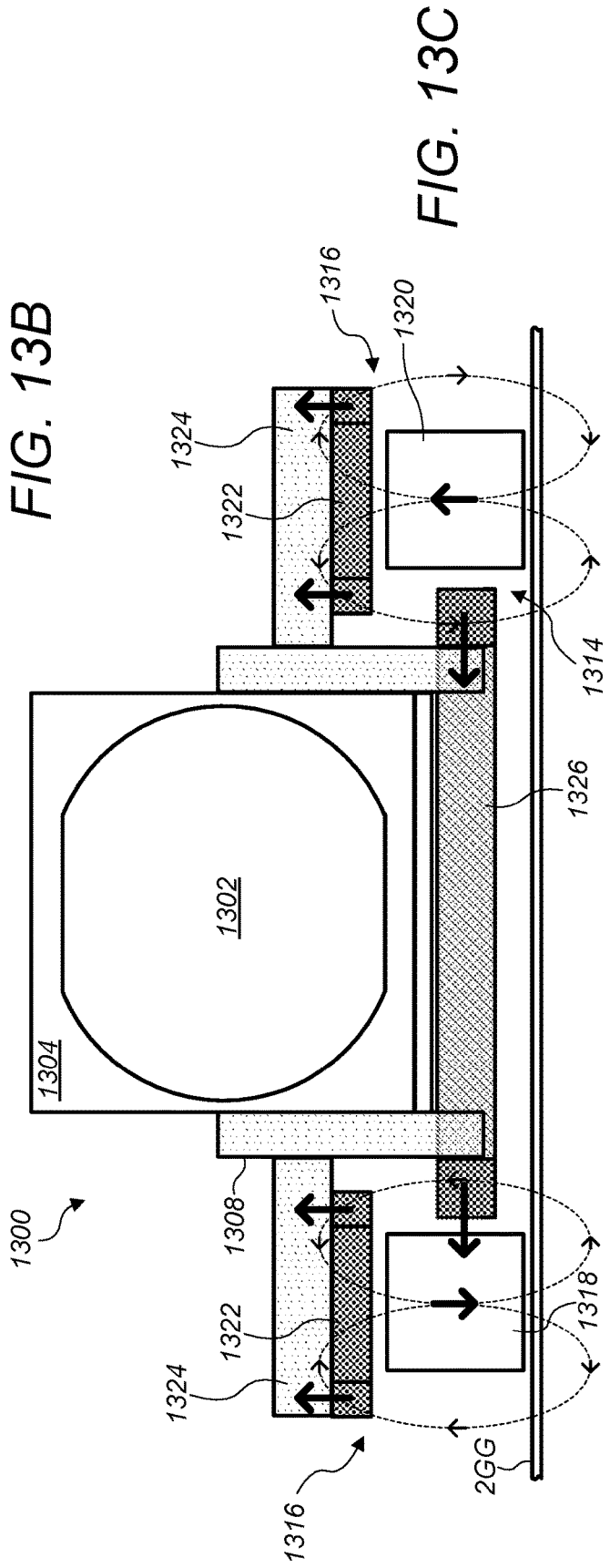

FIG. 13C

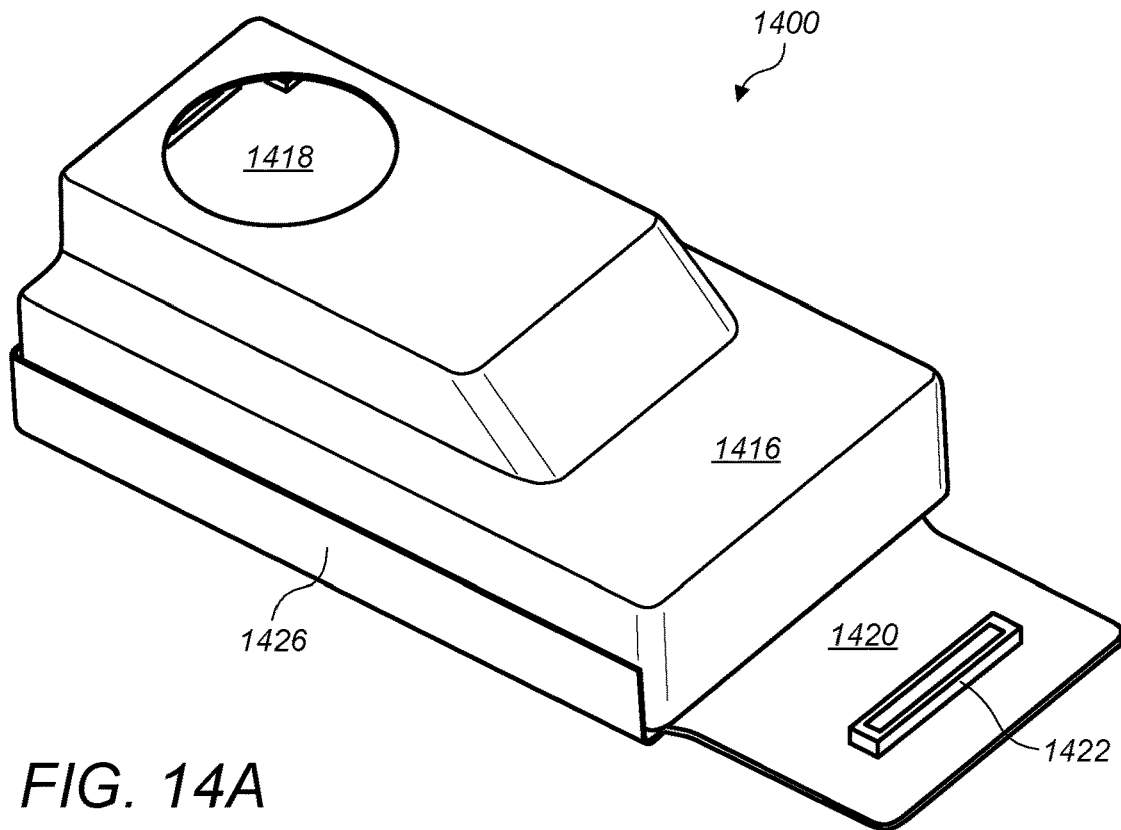

FIG. 14A

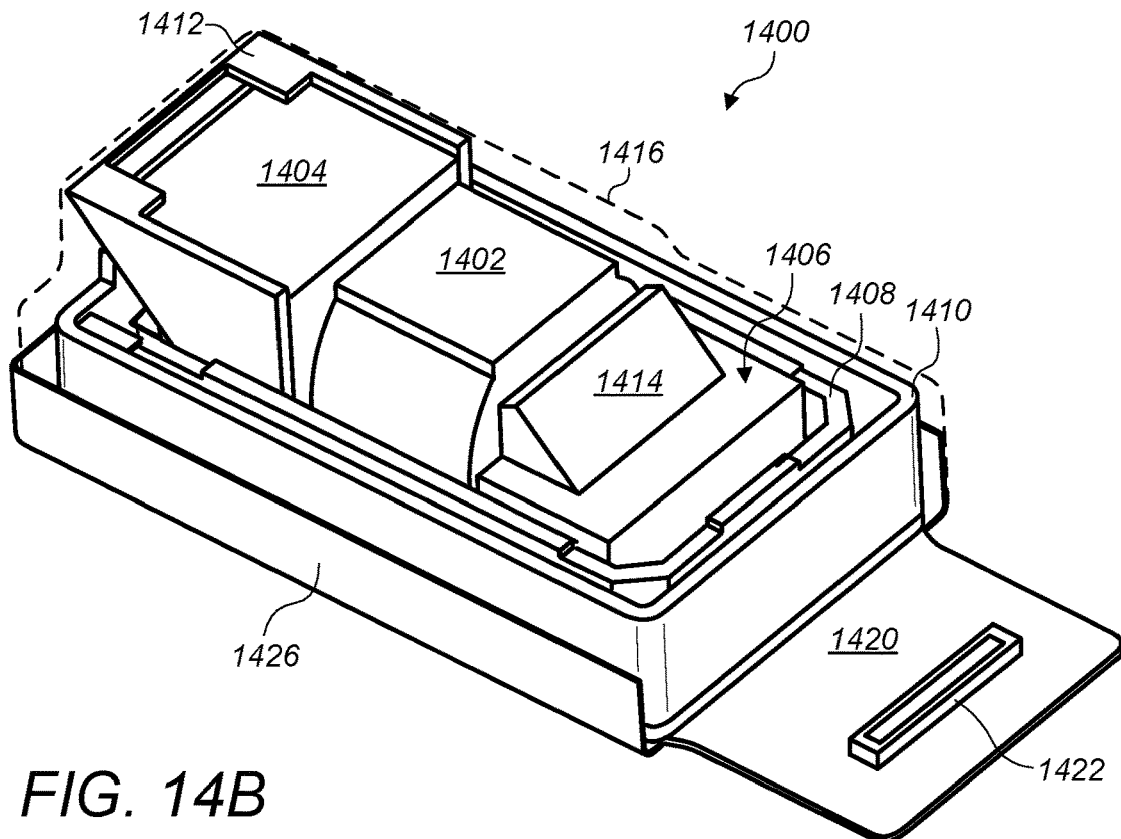

FIG. 14B



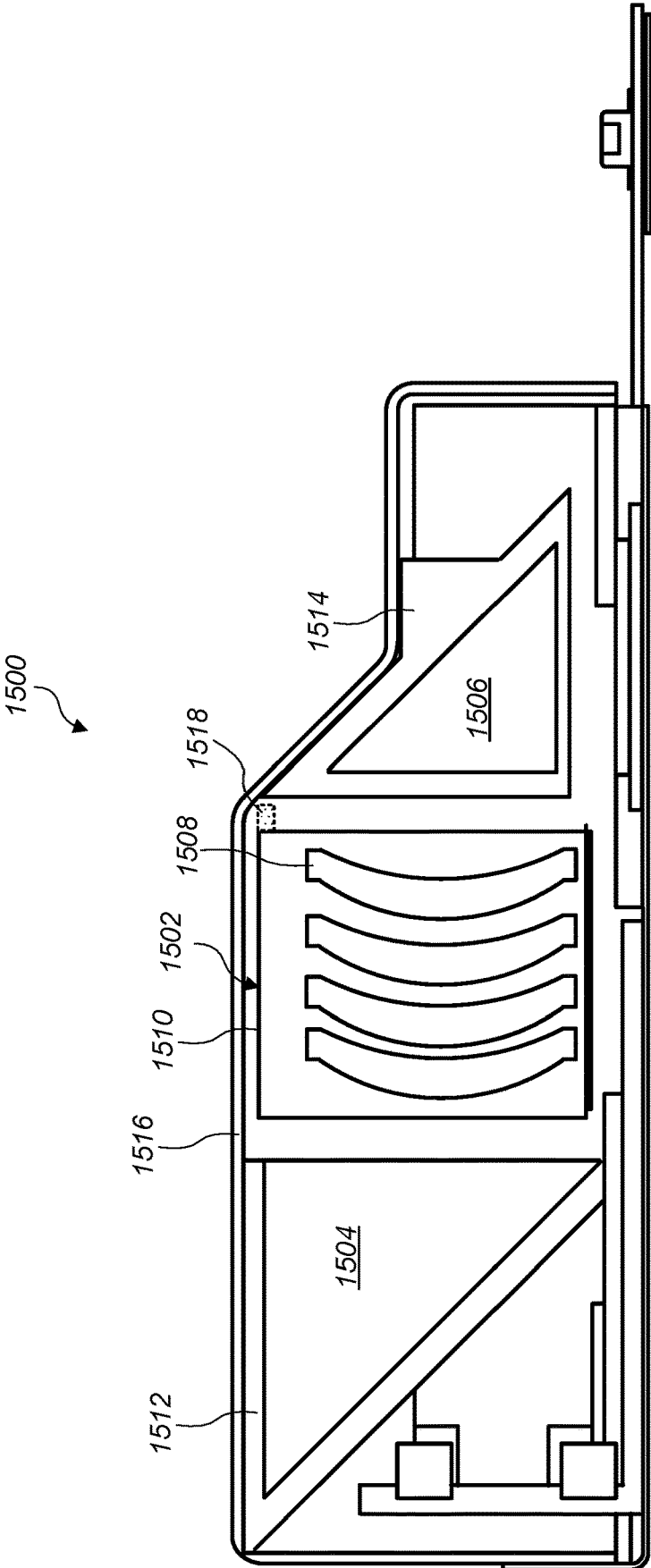

FIG. 15

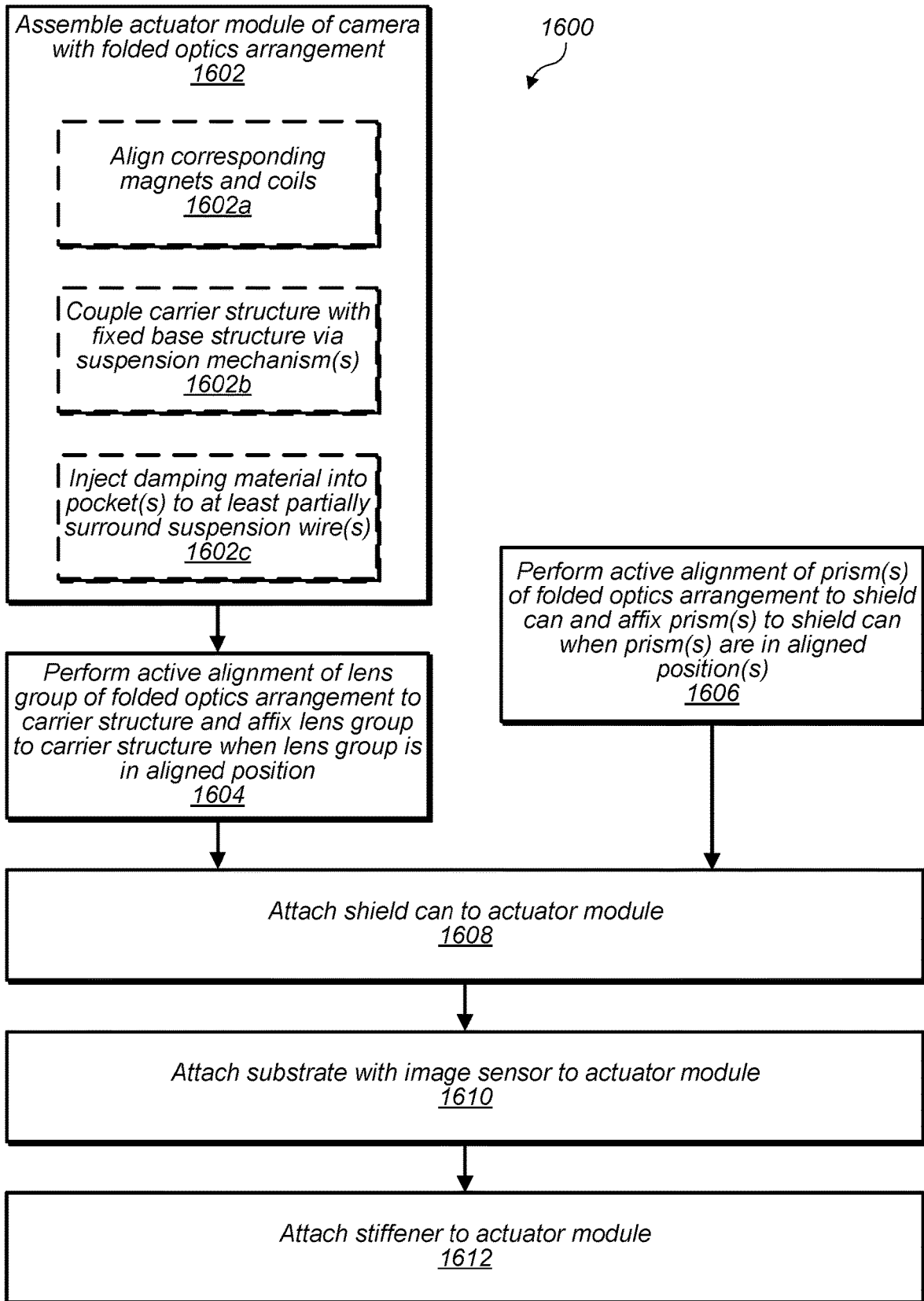

FIG. 16

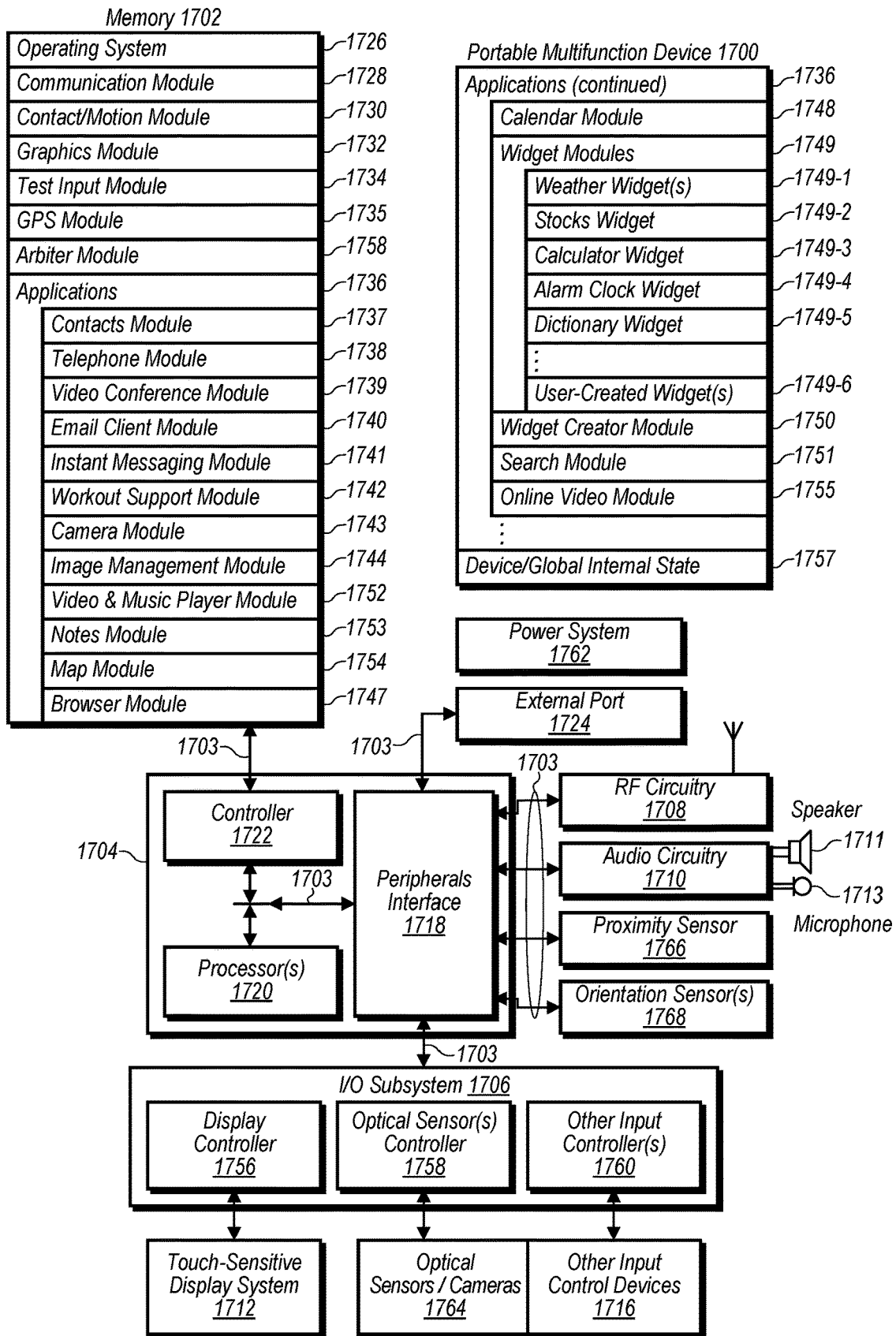

FIG. 17

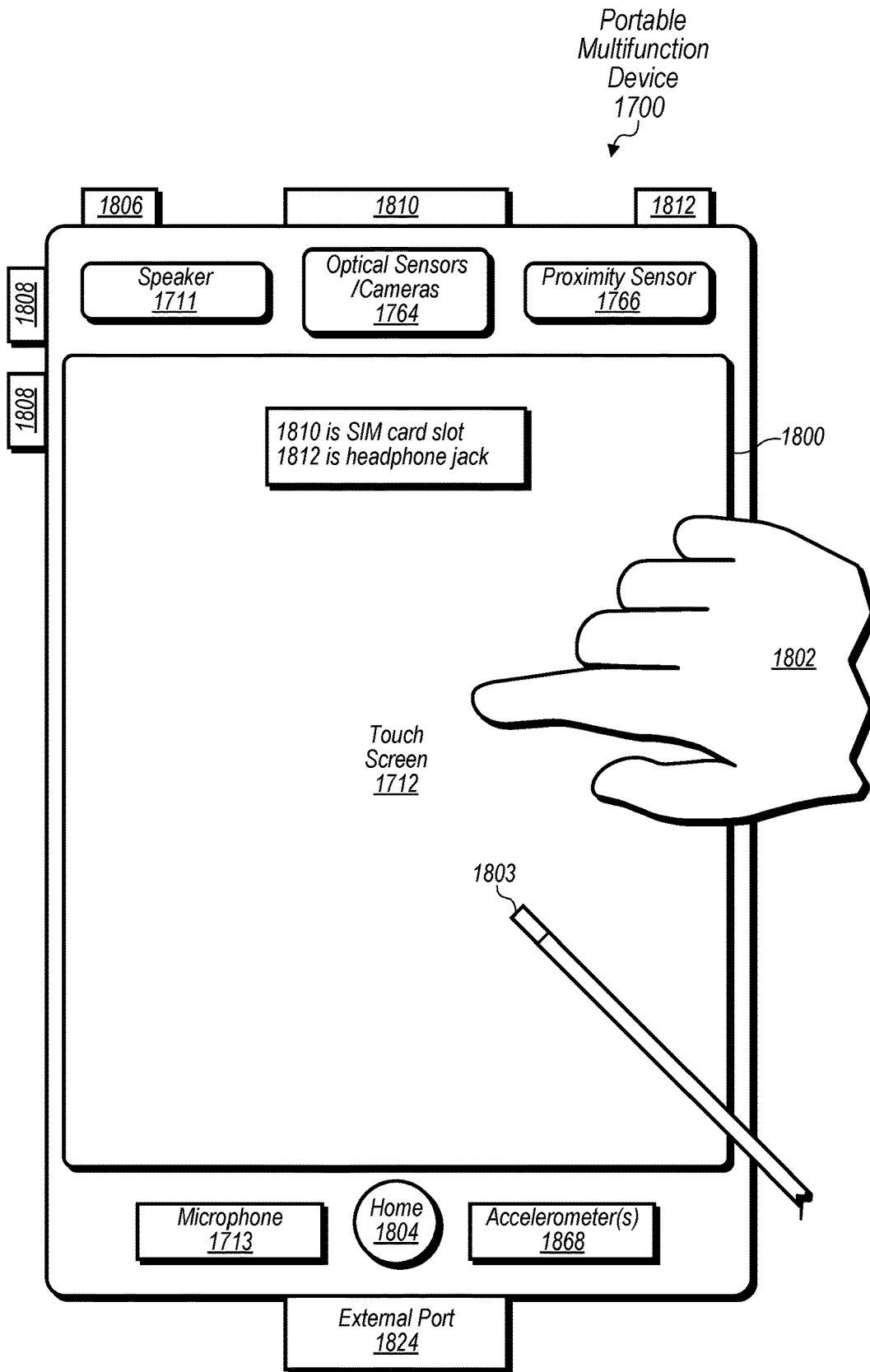

FIG. 18

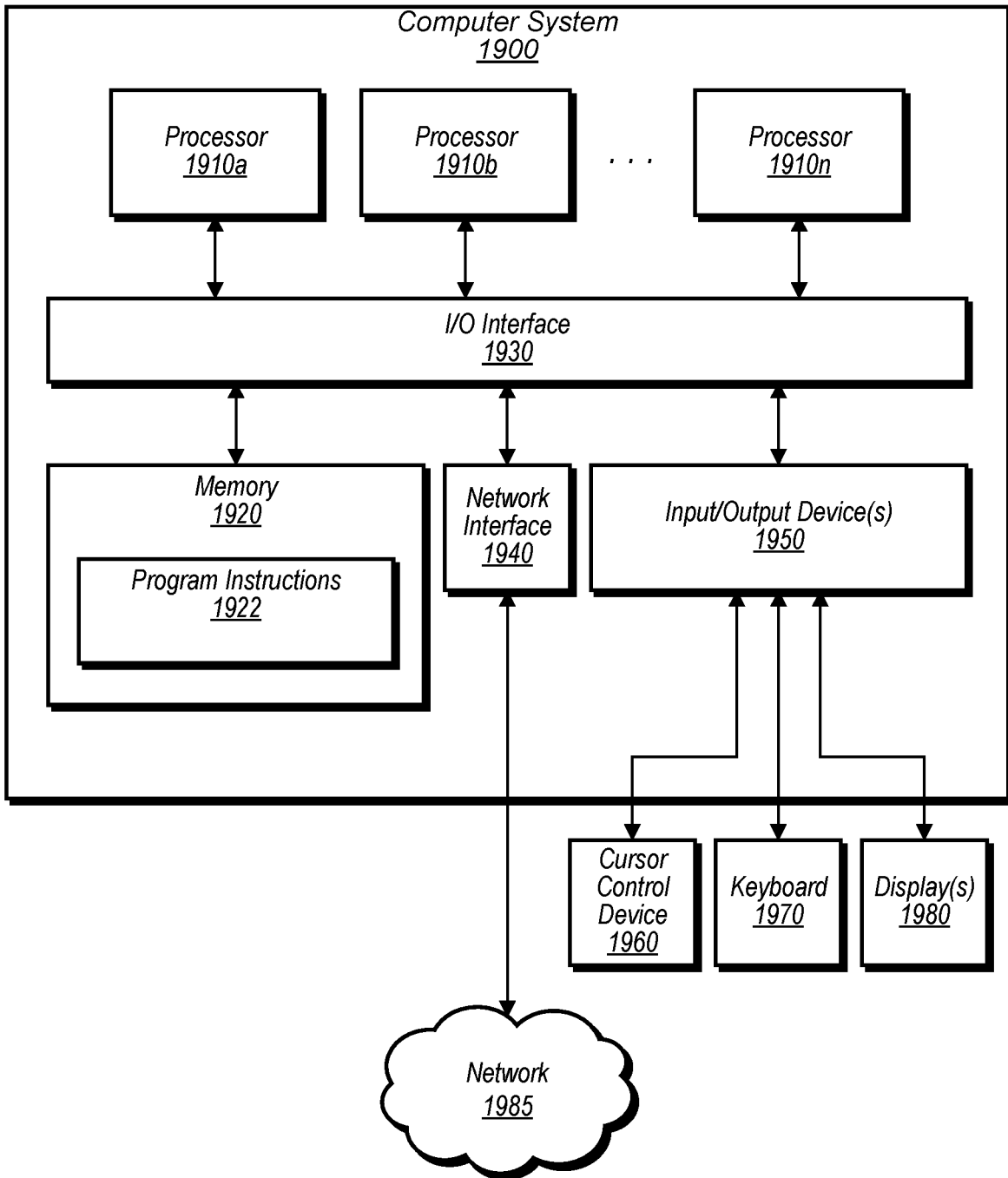

FIG. 19

## CAMERA WITH FOLDED OPTICS HAVING MOVEABLE LENS

[0001] This application is a continuation of U.S. patent application Ser. No. 17/221,620, filed Apr. 2, 2021, which is a continuation of U.S. patent application Ser. No. 16/244,030, filed Jan. 9, 2019, now U.S. Pat. No. 10,969,652, which claims benefit of priority to U.S. Provisional Application No. 62/615,824, filed on Jan. 10, 2018, which are hereby incorporated by reference in their entirety.

### BACKGROUND

#### Technical Field

[0002] This disclosure relates generally to architecture for a camera with folded optics and lens shifting capabilities.

#### Description of the Related Art

[0003] The advent of small, mobile multipurpose devices such as smartphones and tablet or pad devices has resulted in a need for high-resolution, small form factor cameras for integration in the devices. Some small form factor cameras may incorporate optical image stabilization (OIS) mechanisms that may sense and react to external excitation/disturbance by adjusting location of the optical lens on the X and/or Y axis in an attempt to compensate for unwanted motion of the lens. Some small form factor cameras may incorporate an autofocus (AF) mechanism whereby the object focal distance can be adjusted to focus an object plane in front of the camera at an image plane to be captured by the image sensor. In some such autofocus mechanisms, the optical lens is moved as a single rigid body along the optical axis of the camera to refocus the camera.

### BRIEF DESCRIPTION OF THE DRAWINGS

[0004] FIG. 1 illustrates a perspective view of an example camera with a folded optics arrangement, in accordance with some embodiments.

[0005] FIG. 2 illustrates an example of 3-axis movement of a lens group within a folded optics arrangement, in accordance with some embodiments.

[0006] FIG. 3 illustrates a perspective view of an example camera with a folded optics arrangement, in accordance with some embodiments. The camera of FIG. 3 includes an example actuator arrangement for shifting a lens group of the camera along three axes, in accordance with some embodiments.

[0007] FIG. 4 illustrates a side cross-sectional view of the example camera of FIG. 3, in accordance with some embodiments.

[0008] FIG. 5 illustrates a perspective view of an example suspension arrangement for a camera with a folded optics arrangement, in accordance with some embodiments.

[0009] FIG. 6A illustrates a perspective view of another example suspension arrangement for a camera with a folded optics arrangement, in accordance with some embodiments.

[0010] FIG. 6B illustrates an example brace connecting two suspension wires that may be used in a suspension arrangement for a camera with a folded optics arrangement, in accordance with some embodiments.

[0011] FIGS. 7A-7C each illustrate a respective view of yet another example suspension arrangement for a camera with a folded optics arrangement, in accordance with some embodiments. FIG. 7A shows a top view of the suspension

arrangement. FIG. 7B shows a top detail view of a corner portion of the suspension arrangement of FIG. 7A. FIG. 7C shows a perspective detail view of a corner portion of the suspension arrangement of FIG. 7A.

[0012] FIGS. 8A-8D each illustrate a respective view of an example actuator arrangement for 3-axis shifting of a lens group within a folded optics arrangement of a camera, in accordance with some embodiments. FIG. 8A shows a perspective view of the actuator arrangement. FIG. 8B shows a side cross-sectional view of the actuator arrangement. FIG. 8C shows a front cross-sectional view of the actuator arrangement.

[0013] FIG. 8D shows a perspective view of magnets and coils of the actuator arrangement.

[0014] FIGS. 9A-9C each illustrate a respective schematic view of an example actuator arrangement for 3-axis shifting of a lens group within a folded optics arrangement of a camera, in accordance with some embodiments. FIG. 9A shows a schematic side view of the actuator arrangement. FIG. 9B shows a schematic top view of the actuator arrangement. FIG. 9C shows a schematic cross-sectional view of the actuator arrangement.

[0015] FIGS. 10A-10C each illustrate a respective schematic view of another example actuator arrangement for 3-axis shifting of a lens group within a folded optics arrangement of a camera, in accordance with some embodiments. FIG. 10A shows a schematic side view of the actuator arrangement. FIG. 10B shows a schematic top view of the actuator arrangement. FIG. 10C shows a schematic cross-sectional view of the actuator arrangement.

[0016] FIGS. 11A-11C each illustrate a respective schematic view of yet another example actuator arrangement for 3-axis shifting of a lens group within a folded optics arrangement of a camera, in accordance with some embodiments. FIG. 11A shows a schematic side view of the actuator arrangement. FIG. 11B shows a schematic top view of the actuator arrangement. FIG. 11C shows a schematic cross-sectional view of the actuator arrangement.

[0017] FIGS. 12A-12C each illustrate a respective schematic view of still yet another example actuator arrangement for 3-axis shifting of a lens group within a folded optics arrangement of a camera, in accordance with some embodiments. FIG. 12A shows a schematic side view of the actuator arrangement. FIG. 12B shows a schematic top view of the actuator arrangement. FIG. 12C shows a schematic cross-sectional view of the actuator arrangement.

[0018] FIGS. 13A-13C each illustrate a respective schematic view of still yet another example actuator arrangement for 3-axis shifting of a lens group within a folded optics arrangement of a camera, in accordance with some embodiments. FIG. 13A shows a schematic side view of the actuator arrangement. FIG. 13B shows a schematic top view of the actuator arrangement. FIG. 13C shows a schematic cross-sectional view of the actuator arrangement.

[0019] FIGS. 14A and 14B each illustrate a respective perspective view of an example camera with a folded optics arrangement, in accordance with some embodiments. FIG. 14A shows a perspective view of the camera with a shield can covering at least a portion of the internal components of the camera. FIG. 14B shows a perspective view of the camera without the shield covering the internal components.

[0020] FIG. 15 illustrates a side cross-sectional view of an example camera with a folded optics arrangement, in accordance with some embodiments.

[0021] FIG. 16 is a flow chart of an example method for assembling a camera with a folded optics arrangement, in accordance with some embodiments.

[0022] FIG. 17 illustrates a block diagram of a portable multifunction device that may include a camera with a folded optics arrangement, in accordance with some embodiments.

[0023] FIG. 18 depicts a portable multifunction device that may include a camera with a folded optics arrangement, in accordance with some embodiments.

[0024] FIG. 19 illustrates an example computer system that may include a camera with a folded optics arrangement, in accordance with some embodiments.

[0025] This specification includes references to “one embodiment” or “an embodiment.” The appearances of the phrases “in one embodiment” or “in an embodiment” do not necessarily refer to the same embodiment. Particular features, structures, or characteristics may be combined in any suitable manner consistent with this disclosure.

[0026] “Comprising.” This term is open-ended. As used in the appended claims, this term does not foreclose additional structure or steps. Consider a claim that recites: “An apparatus comprising one or more processor units . . .” Such a claim does not foreclose the apparatus from including additional components (e.g., a network interface unit, graphics circuitry, etc.).

[0027] “Configured To.” Various units, circuits, or other components may be described or claimed as “configured to” perform a task or tasks. In such contexts, “configured to” is used to connote structure by indicating that the units/circuits/components include structure (e.g., circuitry) that performs those task or tasks during operation. As such, the unit/circuit/component can be said to be configured to perform the task even when the specified unit/circuit/component is not currently operational (e.g., is not on). The units/circuits/components used with the “configured to” language include hardware—for example, circuits, memory storing program instructions executable to implement the operation, etc. Reciting that a unit/circuit/component is “configured to” perform one or more tasks is expressly intended not to invoke 35 U.S.C. § 112, sixth paragraph, for that unit/circuit/component. Additionally, “configured to” can include generic structure (e.g., generic circuitry) that is manipulated by software and/or firmware (e.g., an FPGA or a general-purpose processor executing software) to operate in manner that is capable of performing the task(s) at issue. “Configure to” may also include adapting a manufacturing process (e.g., a semiconductor fabrication facility) to fabricate devices (e.g., integrated circuits) that are adapted to implement or perform one or more tasks.

[0028] “First,” “Second,” etc. As used herein, these terms are used as labels for nouns that they precede, and do not imply any type of ordering (e.g., spatial, temporal, logical, etc.). For example, a buffer circuit may be described herein as performing write operations for “first” and “second” values. The terms “first” and “second” do not necessarily imply that the first value must be written before the second value.

[0029] “Based On.” As used herein, this term is used to describe one or more factors that affect a determination. This term does not foreclose additional factors that may affect a determination. That is, a determination may be solely based on those factors or based, at least in part, on those factors. Consider the phrase “determine A based on B.” While in this

case, B is a factor that affects the determination of A, such a phrase does not foreclose the determination of A from also being based on C. In other instances, A may be determined based solely on B.

[0030] It will also be understood that, although the terms first, second, etc. may be used herein to describe various elements, these elements should not be limited by these terms. These terms are only used to distinguish one element from another. For example, a first contact could be termed a second contact, and, similarly, a second contact could be termed a first contact, without departing from the intended scope. The first contact and the second contact are both contacts, but they are not the same contact.

[0031] The terminology used in the description herein is for the purpose of describing particular embodiments only and is not intended to be limiting. As used in the description and the appended claims, the singular forms “a,” “an” and “the” are intended to include the plural forms as well, unless the context clearly indicates otherwise. It will also be understood that the term “and/or” as used herein refers to and encompasses any and all possible combinations of one or more of the associated listed items. It will be further understood that the terms “includes,” “including,” “comprises,” and/or “comprising,” when used in this specification, specify the presence of stated features, integers, steps, operations, elements, and/or components, but do not preclude the presence or addition of one or more other features, integers, steps, operations, elements, components, and/or groups thereof.

[0032] As used herein, the term “if” may be construed to mean “when” or “upon” or “in response to determining” or “in response to detecting,” depending on the context. Similarly, the phrase “if it is determined” or “if [a stated condition or event] is detected” may be construed to mean “upon determining” or “in response to determining” or “upon detecting [the stated condition or event]” or “in response to detecting [the stated condition or event],” depending on the context.

#### DETAILED DESCRIPTION

[0033] Some embodiments include camera equipment outfitted with controls, magnets, and voice coil motors to improve the effectiveness of a miniature actuation mechanism for a compact camera module. More specifically, in some embodiments, compact camera modules include actuators to deliver functions such as autofocus (AF) and/or optical image stabilization (OIS). One approach to delivering a very compact actuator for AF and/or OIS is to use a voice coil motor (VCM) actuator.

[0034] Reference will now be made in detail to embodiments, examples of which are illustrated in the accompanying drawings. In the following detailed description, numerous specific details are set forth in order to provide a thorough understanding of the present disclosure. However, it will be apparent to one of ordinary skill in the art that some embodiments may be practiced without these specific details. In other instances, well-known methods, procedures, components, circuits, and networks have not been described in detail so as not to unnecessarily obscure aspects of the embodiments.

[0035] Described here are folded optics arrangements for providing a reduced-height imaging system. The arrangements discussed throughout generally comprise one or more lenses positioned between two light path folding elements,

which collectively provides a dual-folded light path. The one or more lenses may be moveable between the light path folding elements to provide autofocus and/or image stabilization during imaging. FIG. 1 shows a generalized example of a camera 100 with a folded optics arrangement. The example X-Y-Z coordinate system shown in FIG. 1 is used to discuss aspects of systems and/or system components, and may apply to embodiments described throughout this disclosure.

**[0036]** In various embodiments, the camera 100 may include a lens group 102, a first prism 104, a second prism 106, and an image sensor package 108. The lens group 102 may include one or more lens elements. In some embodiments, the lens group 102 may be located between the first prism 104 and the second prism 106, forming the folded optics arrangement. Light may follow an optical path 110 that is folded by the first prism 104 such that the light is directed towards the lens group 102, passes through the lens group 102, and is folded by the second prism 106 such that the light is directed towards the image sensor package 108. In some examples, light may enter an object side of the first prism 104 along the Z-axis. The first prism 104 may redirect the light to propagate along the X-axis (which may be parallel to an optical axis defined by the lens group 102) towards the lens group 102. The second prism 106 may redirect the light to propagate along the Z-axis (which may be orthogonal to a plane defined by the image sensor package 108), e.g., such that the light exits an image side of the second prism 106 towards the image sensor package 108. The first prism 104, the lens group 102, and/or the second prism 106 may be positioned along a common axis (e.g., the X-axis, the optical axis defined by the lens group 102, etc.). According to some examples, the optical path 110 may be contained within a plane (e.g., the X-Z plane), and the image sensor package 108 may extend along a different plane (e.g., the X-Y plane).

**[0037]** In some embodiments, the object side of the first prism 104 may extend along the X-Y plane. Furthermore, the first prism 104 may include a pair of opposing lateral sides that each extend along the X-Z plane, a lens group facing side that extends along the Y-Z plane, and a reflecting surface side that is angled relative to one or more of the other sides of the first prism 104. For example, the reflecting surface side of the first prism 104 may include a reflective surface that is angled so as to redirect light received from the object side of the first prism 104 towards the lens group 102 (via the lens group facing side of the first prism 104), as discussed above.

**[0038]** In some embodiments, the image side of the second prism 106 may extend along the X-Y plane, e.g., proximate the image sensor package 108. Furthermore, the second prism 106 may include a pair of opposing lateral sides that each extend along the X-Z plane, a lens group facing side that extends along the Y-Z plane, and a reflecting surface side that is angled relative to one or more of the other sides of the second prism 106. For example, the reflecting surface side of the second prism 106 may include a reflective surface that is angled so as to redirect light received from the lens group 102 (via the lens group facing side of the second prism 106) towards the image sensor package (via the image side of the second prism 106), as discussed above.

**[0039]** While the light path folding elements are shown in various figures as comprising prisms (e.g., the first prism 104 and the second prism 106), the camera systems and/or

folded optics arrangements described herein may include any suitable light path folding element (e.g., a mirror or the like) or combination of elements. In some embodiments, one or more of the light path folding elements may also act as a lens element (or combination of lens elements). For example, one or more lens elements (e.g., other than those of the lens group 102) may be integrated with the first prism 104 (and/or the second prism 106) such that the prism acts as a lens element. Additionally, or alternatively, the first prism 104 (and/or the second prism 106) may be shaped such that the prism acts as a lens element.

**[0040]** As will be discussed in further detail below, the lens group 102 may be coupled with an actuator structure that is configured to move the lens group 102 along multiple axes, e.g., to provide autofocus (AF) and/or optical image stabilization (OIS) functionality. FIG. 2 shows an example of 3-axis movement of the lens group 102 to provide AF and/or OIS functionality. For example, the lens group 102 may be shifted (e.g., by an actuator structure, such as the actuator structures/arrangements discussed in further detail below) along the X-axis to provide AF movement. Additionally, or alternatively, the lens group 102 may be shifted along the Z-axis to provide OIS-X movement (e.g., movement that shifts the image projected on the image sensor package 108 in one or more directions parallel to the X-axis). Additionally, or alternatively, the lens group 102 may be shifted along the Y-axis to provide OIS-Y movement (e.g., movement that shifts the image projected on the image sensor package 108 in one or more directions parallel to the Y-axis). Components of the camera 100 (e.g., the lens group 102, the first prism 104, the second prism 106, and/or the image sensor package 108, etc.) may be used with any of the actuator arrangements described in the following figures.

**[0041]** As mentioned above, the camera systems described here may comprise an actuator system to move the lens group relative to the light path folding elements (e.g., the first prism 104 and the second prism 106). The actuator arrangements described here may generally comprise a frame (e.g., the carrier structure discussed below), one or more suspension structures for moveably holding the frame relative to the rest of the camera, and an actuator module for controlling movement of the frame. FIGS. 3 and 4 show perspective and side cross-sectional views of one such variation, and include an example camera 300 with a folded optics arrangement in accordance with some embodiments.

**[0042]** In some embodiments, the camera 300 may include a lens group 302, a first prism 304, and a second prism 306, and an image sensor 308. The lens group 302 may include one or more lens elements 310 disposed within a lens holder 312.

**[0043]** In various embodiments, the camera 300 may include an actuator module 314 that provides for shifting the lens group 302 along multiple axes, e.g., to provide AF and/or OIS movement. In some embodiments, the actuator module 314 may comprise a voice coil motor (VCM) actuator module that includes one or more VCM actuators, e.g., as shown in FIGS. 3 and 4.

**[0044]** In some examples, the actuator module 314 may include a carrier structure 316 and a fixed base structure 318. According to some embodiments, the carrier structure 316 may be attached to the lens group 302. In some examples, the carrier structure 316 may be attached to the lens group 302, and movement of the carrier structure 316 (e.g., due to actuation of one or more actuators of the actuator module



**314**) may cause movement of the lens group **302**, such that the lens group **302** moves together with the carrier structure **316**.

**[0045]** In various embodiments, the carrier structure **316** may extend around the first prism **304**, the lens group **302**, and the second prism **306**, e.g., as shown in FIG. 3. The carrier structure **316** may define a periphery within which at least a respective portion of each of the first prism **304**, the lens group **302**, and the second prism **306** are disposed. The carrier structure **316** may have multiple sides. For example, the carrier structure **316** may have a first side, a second side, a third side, and a fourth side. The first side may be a lateral side extending along the X-axis and along the side surfaces of the optical elements. The second side may be a lateral side extending along the X-axis and along the opposite side surfaces of the optical elements. The third side may be a distal/object side extending along the Y-axis, and may be positioned behind at least a portion of the reflecting surface side of the first prism **104** (e.g., such that the first prism **104** is disposed between the lens group **102** and the carrier structure **316**). The fourth side may be a proximal/image side extending along the Y-axis, and may be positioned in front of at least a portion of the reflecting surface side of the second prism **106** (e.g., such that the second prism **106** is disposed between the lens group **102** and the carrier structure **316**). While FIGS. 3 and 4 show the carrier structure **316** encircling the optical elements of the folded optics arrangement (e.g., the first prism **304**, the lens group **302**, and the second prism **306**), it is understood that the carrier structure **316** may partially encircle the optical elements in some embodiments. As a non-limiting example, one of the sides of the carrier structure **316** may comprise two parts that are spaced apart from each other by a gap, so that the carrier structure **316** partially encircles the optical elements. As another non-limiting example, the carrier structure **316** may comprise three sides (e.g., the carrier structure **316** may not include one of the four sides described above), so that the carrier structure **316** partially encircles the optical elements.

**[0046]** According to some embodiments, the fixed base structure **318** may include a component of the camera **300** to which the carrier structure **316** is moveably connected (e.g., via suspension elements). In some examples, the fixed base structure **318** may at least partially extend around the carrier structure **316**. The fixed base structure **318** may be fixed (or static) relative to movement of the carrier structure **316**. Furthermore, the fixed base structure **318** may be fixed relative to the first prism **304**, the second prism **306**, and/or the image sensor **308**. The fixed base structure **318** may be spaced apart from the carrier structure **316** to allow for movement (e.g., AF and/or OIS movement) of the carrier structure **316** within a periphery defined by the fixed base structure **318**. In some examples, the fixed base structure **318** may include multiple components that are joined or otherwise fixed relative to each other.

**[0047]** In various embodiments, the actuator module **314** may include one or more AF VCM actuators and/or one or more OIS VCM actuators. In some embodiments, the actuator module **314** may include an AF VCM actuator **320** (e.g., to provide AF movement), an OIS-Y VCM actuator **322** (e.g., to provide OIS-Y movement), and an OIS-X VCM actuator **324** (e.g., to provide OIS-X movement).

**[0048]** The AF VCM actuator **320** may include one or more magnets and one or more coils. In some examples, the AF VCM actuator **320** may include a pair of AF magnets

**326** and an AF coil **328**. The AF coil **328** may be electrically driven to magnetically interact with the AF magnets **326** to produce Lorentz forces that move the AF coil **328**, the carrier structure **316**, and/or the lens group **302** along an axis (e.g., along axis **202** of FIG. 2) to provide AF movement of the lens group **302**. The AF magnets **326** may be attached to the fixed base structure **318**. The AF coil **328** may be attached to the carrier structure **316** (e.g., to the distal/object side of the carrier structure **316**). According to some embodiments, the AF coil **328** may extend from the carrier structure **316** such that the AF coil **328** is nested between the AF magnets **326**. In some cases, the AF coil **328** may be attached to a protrusion **330** of the carrier structure **316**, and the protrusion **330** may extend toward the AF magnets **326**. In some instances, the AF coil **328** may be wound around the protrusion **330**. In some embodiments, the AF coil **328** may have a long axis that is parallel to respective long axes of the AF magnets **326**. In various embodiments, the AF VCM actuator **320** may be tucked within a space under a portion of the first prism **304**, e.g., as indicated in FIGS. 3 and 4. In this manner, the impact of the AF VCM actuator **320** on the dimension of the system along its long axis (also referred to herein as the “system X-axis”) and along its vertical axis (also referred to herein as the “system Z-axis”) may be reduced or eliminated.

**[0049]** The OIS-Y VCM actuator **322** may include one or more magnets and one or more coils. In some examples, the OIS-Y VCM actuator **322** may include a pair of OIS-Y magnets **332** and an OIS-Y coil **334**. The OIS-Y coil **334** may be electrically driven to magnetically interact with the OIS-Y magnets **332** to produce Lorentz forces that move the OIS-Y coil **334**, the carrier structure **316**, and/or the lens group **302** along an axis (e.g., along axis **206** of FIG. 2) to provide OIS-Y movement of the lens group **302**. The OIS-Y magnets **332** may be attached to the fixed base structure **318**. The OIS-Y coil **334** may be attached to the carrier structure **316** (e.g., to a lateral side of the carrier structure **316**). According to some embodiments, the OIS-Y coil **334** may extend from the carrier structure **316** such that the OIS-Y coil **334** is nested between the OIS-Y magnets **332**. In some cases, the OIS-Y coil **334** may be attached to a protrusion **336** of the carrier structure **316**, and the protrusion **336** may extend toward the OIS-Y magnets **332**. In some instances, the OIS-Y coil **334** may be wound around the protrusion **336**. In some embodiments, the OIS-Y coil **334** may have a long axis that is parallel to respective long axes of the OIS-Y magnets **332**. While a single OIS-Y VCM actuator **322** is shown in FIG. 3, it should be understood that various embodiments may include multiple OIS-Y VCM actuators. For instance, the camera **300** may include a second OIS-Y VCM actuator opposite (e.g., with respect to the lens group **302**) the first OIS-Y VCM actuator **322** depicted in FIG. 3.

**[0050]** The OIS-X VCM actuator **324** may include one or more magnets and one or more coils. In some examples, the OIS-X VCM actuator **324** may include a pair of OIS-X magnets **338** and an OIS-X coil **340**. The OIS-X coil **340** may be electrically driven to magnetically interact with the OIS-X magnets **338** to produce Lorentz forces that move the OIS-X coil **340**, the carrier structure **316**, and/or the lens group **302** along an axis (e.g., along axis **204** of FIG. 2) to provide OIS-X movement of the lens group **302**. The OIS-X magnets **338** may be attached to the fixed base structure **318**. The OIS-X coil **340** may be attached to the carrier structure **316** and/or the lens holder **312**. According to some embodi-

ments, the OIS-X coil 340 may extend from the carrier structure 316 such that the OIS-X coil 340 is nested between the OIS-X magnets 338. In some cases, the OIS-X coil 340 may be attached to a protrusion 342 of the carrier structure 316, and the protrusion 342 may extend toward the OIS-X magnets 338. In some instances, the OIS-X coil 340 may be wound around the protrusion 342. In some embodiments, the OIS-X coil 340 may have a long axis that is parallel to respective long axes of the OIS-X magnets 338.

[0051] In some embodiments, the camera 300 may include a suspension mechanism 344 (or “suspension arrangement”) from which the carrier structure 316 may be suspended relative to the fixed base structure 318. The suspension mechanism 344 may provide compliance and/or stiffness for controlled movement of the carrier structure 316. According to some examples, the suspension mechanism 344 may include a set of one or more top springs 346 (e.g., leaf springs) attached to respective top corner portions of the carrier structure 316. Furthermore, a respective suspension wire 348 may extend downward from each of the top springs 346. A bottom end portion of the respective suspension wire 348 may be attached to a fixed (or static) structure. Additionally, or alternatively, the suspension mechanism 344 may include a set of one or more bottom springs 350 attached to respective bottom corner portions of the carrier structure 316. Furthermore, a respective suspension wire 352 may extend upward from each of the bottom springs 350. A top end portion of the respective suspension wire 352 may be attached to a fixed (or static) structure. In some embodiments, the top and/or bottom springs may provide compliance for OIS-X movement in a controlled manner, and may provide sufficient stiffness to resist Z-axis movement of the lens group 302 during OIS-Y and/or AF movement. Furthermore, the suspension wires may provide compliance for OIS-Y and/or AF movement in a controlled manner, and may provide sufficient stiffness to resist X-Y plane movement of the lens group during OIS-X movement. Various non-limiting example suspension arrangements are described in greater detail below with reference to FIGS. 5-7C.

[0052] In various embodiments, the camera 300 may include a substrate 354 below the second prism 306. The image sensor 308 may be coupled with the substrate 354. In some embodiments, a filter 356 (e.g., an infrared filter) may also be coupled to the substrate 354. For instance, the filter 356 may be located above the image sensor 308 such that light passes through the filter 356 before reaching the image sensor 308.

[0053] In some embodiments, the camera 300 may include a first prism holder 356 that holds the first prism 304. In some embodiments, the first prism 304 may be attached to one or more fixed (or static) structures of the camera 300 via the first prism holder 356. For instance, the first prism holder 356 may be attached to a shield can (not shown) in some cases. Additionally, or alternatively, the camera 300 may include a second prism holder 358 that holds the second prism 306. In some embodiments, the second prism 306 may be attached to one or more fixed (or static) structures of the camera 300 via the second prism holder 358. For instance, the second prism holder 358 may be attached to the shield can in some cases.

[0054] The suspension arrangements described here may generally include one or more springs (e.g., leaf springs), one or more wires (e.g., suspension wires), and/or one or

more flexure arms. FIGS. 5-7C show various example suspension arrangements that may be used with any of the camera systems and/or actuator arrangements described herein. Although shown in FIGS. 3 and 4 as having a suspension arrangement comprising top (or “upper”) springs and bottom (or “lower”) springs, the suspension arrangement need not include both. For example, FIG. 5 illustrates a perspective view of an example suspension arrangement 500 (e.g., for a camera with a folded optics arrangement) that may have one or more top springs and one or more wires extending downward from the top spring(s).

[0055] In some embodiments, the camera may include a lens group 502, a first prism 504, and a second prism 506. In various embodiments, the camera may include an actuator module that provides for shifting the lens group 502 along multiple axes, e.g., to provide AF and/or OIS movement. In some examples, the actuator module may include a carrier structure 508 and a fixed base structure (e.g., the fixed base structure 318 of FIG. 3). According to some embodiments, the carrier structure 508 may be attached to the lens group 502. For instance, the carrier structure 508 may be attached to the lens group 502 such that the lens group 502 moves together with the carrier structure 508. In various embodiments, the carrier structure 508 may extend around the first prism 504, the lens group 502, and the second prism 506, e.g., as shown in FIG. 5. The carrier structure 508 may define a periphery within which at least a respective portion of each of the first prism 504, the lens group 502, and the second prism 506 are disposed.

[0056] In various embodiments, the suspension arrangement 500 may include a set of one or more top springs 510 attached to respective top corner portions of the carrier structure 508. Furthermore, a respective suspension wire 512 may extend downward from each of the top springs 510. A bottom end portion 514 of the respective suspension wire 512 may be attached to a fixed (or static) structure.

[0057] In some embodiments, the camera and/or the suspension arrangement 500 may include a damper that dampens movement of one or more of the suspension wires 512. For instance, the suspension wires 512 may be at least partially disposed within a viscoelastic material 516 (e.g., a viscoelastic gel). In some examples, one or more protrusions 518 may protrude from the carrier structure 508 and form one or more pockets within which the viscoelastic material 516 may be disposed. In some instances, the viscoelastic material 516 may be injected into a pocket through a hole in the base structure (not shown) that surrounds the carrier structure 508. For example, an insertion needle (not shown) may be inserted through the hole in the base structure to access the pocket and inject the viscoelastic material 516 into the pocket. In some embodiments, the protrusions 518 may extend from corner portions of the carrier structure 508, e.g., as shown in FIG. 5. While FIG. 5 shows protrusions 518 that form pockets configured to contain, at least in part, the viscoelastic material 516, it should be understood that the viscoelastic material 516 may be disposed within pockets formed differently, e.g., via pockets formed of protrusions from a structure other than the carrier structure 508, pockets formed via a combination of the carrier structure 508 and one or more other structures, etc. The viscoelastic material 516 may be located along any portion(s) of the length of a suspension wire 512. In some embodiments, the viscoelastic material 516 may be located along a central portion of the length of a suspension wire 512.

[0058] In some embodiments, the carrier structure 508 may define one or more cutout portions and/or one or more recessed portions, e.g., for weight reduction and/or mass balancing purposes. In some examples, the cutout portion(s) and/or recessed portion(s) may be positioned so as to reduce weight in certain areas to appropriately distribute weight, e.g., in camera systems that are not symmetric in one or more directions. For instance, it may be desirable to distribute the weight of components of a camera system in a manner that avoids undesirable moments about the center of gravity of the lens group 502. In some examples, the weight reduction may increase system responsiveness to actuation of the actuator module and/or may improve energy efficiency (e.g., by reducing the required amount of drive current to the coils). In the example illustrated in FIG. 5, the carrier structure 508 defines cutout portions 520 that oppose one another with respect to the first prism 504. Furthermore, the carrier structure 508 defines cutout portions 522 that oppose one another with respect to the second prism 506. Furthermore, the carrier structure 508 defines a recessed portion 524 proximate the second prism 506. In some instances, the cutout portion(s) and/or the recessed portion(s) may be located and/or sized to reduce or eliminate moments (e.g., caused by actuation forces) about a center of gravity of the lens group 502 and/or the carrier structure 508. Any of the carrier structures described above and below (e.g., with reference to FIGS. 3, 4, 7A-7C, 8B, 8C, and 9A-15) may include one or more cutout portions and/or one or more recessed portions in some embodiments. Additionally, or alternatively, the cutout portion(s) and/or the recessed portion(s) may be used with any suspension arrangement described herein.

[0059] FIG. 6A illustrates a perspective view of another example suspension arrangement 600 (e.g., for a camera with a folded optics arrangement) that may have one or more top (or “upper”) springs and one or more bottom (or “lower”) springs. One or more wires may extend downward from the top spring(s). Furthermore, one or more wires may extend upward from the bottom spring(s). While the suspension arrangement 600 is described as having top and bottom springs, the suspension arrangement 600 may include one or more additional features (that may not be shown in FIG. 6A) in some embodiments.

[0060] In various embodiments, the suspension arrangement 600 may include a set of one or more top springs 510 attached to respective top corner portions of the carrier structure 508. Furthermore, a respective suspension wire 512 may extend downward from each of the top springs 510. A bottom end portion 514 of the respective suspension wire 512 may be attached to a fixed (or static) structure.

[0061] Furthermore, the suspension arrangement 600 may include a set of one or more bottom springs 602 attached to respective bottom corner portions of the carrier structure 508. Furthermore, a respective suspension wire 604 may extend upward from each of the bottom springs 602. A top end portion 606 of the respective suspension wire 604 may be attached to a fixed (or static) structure. In some embodiments, one or more of the suspension wires 604 may be coupled with a corresponding suspension wire 512 (e.g., a suspension wire 512 that extends downward from a top spring 510 at a same corner portion) via a respective brace to limit relative movement between the corresponding suspension wires 512 and 604 in one or more degrees of freedom. For example, as indicated in FIG. 6B, the brace

608 may be a structure that connects the corresponding suspension wires 512 and 604 at their midpoints (e.g., midpoints along the directions in which the suspension wires 512 and 604 extend). However, it should be understood that the brace 608 may additionally or alternatively connect the suspension wires 512 and 604 at one or more other portions of the wires. In various embodiments, due to the brace 608, the corresponding suspension wires 512 and 604 may maintain a constant relative distance from each other at the portion(s) in which they are connected by the brace 608.

[0062] In some embodiments the camera and/or the suspension arrangement 600 may include a damper that dampens movement of one or more of the suspension wires 512 and/or the suspension wires 604. For instance, the suspension wires 512, 604 may be at least partially disposed within a viscoelastic material 516 (e.g., a viscoelastic gel). In some examples, one or more protrusions 518 may protrude from the carrier structure 508 and form one or more pockets within which the viscoelastic material 516 may be disposed. In some examples, a pocket may be formed to contain viscoelastic material 516 that surrounds one or more portions of the suspension wire 512 and not the suspension wire 604, e.g., as illustrated in FIG. 6A. However, in some embodiments, the protrusions 508 may extend further out to form a larger pocket such that the viscoelastic material 516 within the larger pocket may surround both the suspension wire 512 and the suspension wire 604. In other embodiments, a separate pocket may be formed for each respective wire. For instance, a first pocket may be formed to contain viscoelastic material within which at least a portion of the suspension wire 512 may be disposed, and a second pocket may be formed to contain viscoelastic material within which at least a portion of the suspension wire 604 may be disposed.

[0063] As mentioned above, some embodiments may include a suspension arrangement comprising flexure arms. FIGS. 7A-7C each illustrate a respective view of yet another example suspension arrangement 700 (e.g., for a camera with a folded optics arrangement) that may include such flexure arms. FIG. 7A shows a top view of the suspension arrangement 700. FIG. 7B shows a top detail view of a corner portion of the suspension arrangement 700 of FIG. 7A. FIG. 7C shows a perspective detail view of a corner portion of the suspension arrangement 700 of FIG. 7A.

[0064] According to various embodiments, the suspension arrangement 700 may include a combination of a spring-and-wire suspension mechanism (e.g., as discussed above with reference to FIGS. 3 and 5-6B) and a flexure suspension mechanism. For instance, the suspension arrangement 700 may include a set of one or more top springs 702 attached to respective top corner portions of a carrier structure 704. The carrier structure 704 may be attached to sides of a lens group 706, e.g., as shown in FIG. 7A. Furthermore, one or more coils 708 (e.g., coils of one or more VCM actuators) may be attached to the carrier structure 704. In some examples, a respective suspension wire 708 may extend downward from each of the top springs 702, e.g., as shown in FIGS. 7A-7C. A bottom end portion 710 of the respective suspension wire 708 may be attached to a fixed (or static) structure (e.g., a portion of the fixed base structure 716 not shown).

[0065] In some embodiments, the suspension arrangement 700 may include a bottom flexure suspension mechanism 712 attached to a lower portion (or bottom) of the carrier

structure 704. The bottom flexure suspension mechanism 712 may include a set of one or more flexure arms 714 that is coupled with the carrier structure 704 and the fixed base structure 716 that surrounds the carrier structure 704. In some instances, the set of flexure arms 714 may be attached to an inner frame that is part of the carrier structure 704. In other instances, the inner frame may be a separate structure that is coupled with the carrier structure 704. Similarly, the set of flexure arms 714 may be attached to an outer frame that is part of the fixed base structure 706 in some instances. In other instances, the outer frame may be a separate structure that is coupled with the fixed base structure 706.

[0066] In some examples, the bottom flexure suspension mechanism 712 may include one or more flexure stabilizers 718 that connect adjacent flexure arms 714 with one another to prevent the connected flexure arms 714 from interfering (e.g., bumping, tangling, etc.) with one another during movement of the flexure arms 714. In various embodiments, the flexure arms 714 may extend parallel to one another. Furthermore, in some embodiments, the flexure stabilizers 718 may extend at an angle to (e.g., orthogonal to) the flexure arms 714.

[0067] Although in FIGS. 7A-7C the suspension arrangement 700 is shown as including a top spring 702 and a bottom flexure suspension mechanism 712, it should be understood that in various embodiments the suspension arrangement 700 may additionally, or alternatively, include a bottom spring and/or a top flexure suspension mechanism.

[0068] In some embodiments, a viscoelastic material may be disposed at one or more locations of the suspension arrangement 700 to dampen movement of one or more portions of the spring-and-wire suspension mechanism and/or the flexure suspension mechanism. For instance, one or more pockets may be formed by one or more structures (e.g., the carrier structure 704 and/or the fixed base structure 716), and the pocket(s) may be configured to at least partially be filled with the viscoelastic material such that the viscoelastic material at least partially surrounds one or more wires, one or more flexure arms, and/or one or more flexure stabilizers of the suspension arrangement 700.

[0069] According to various embodiments, the camera systems described here may comprise actuator arrangements that may be used to move a carrier structure (which, as discussed above, may cause movement of a lens group). FIGS. 8A-13C show various example actuator arrangements that may be used with any of the camera systems, carrier structures, and/or suspension arrangements described above (e.g., with reference to FIGS. 3-7C). For instance, FIGS. 8A-8D each illustrate a respective view of an example actuator arrangement 800 for 3-axis shifting of a lens group within a folded optics arrangement of a camera. FIG. 8A shows a perspective view of the actuator arrangement 800. FIG. 8B shows a side cross-sectional view of the actuator arrangement 800. FIG. 8C shows a front cross-sectional view of the actuator arrangement 800. FIG. 8D shows a perspective view of magnets and coils of the actuator arrangement 800. The actuator arrangement 800 shown in FIGS. 8A-8D may be the same as, or similar to, the arrangement of actuator module 314 shown in FIGS. 3 and 4.

[0070] In various embodiments, the camera may include a lens group 802, a first prism 804, and a second prism 306, and an image sensor 808. The lens group 802 may include one or more lens elements 810 disposed within a lens holder

812. In various embodiments, the camera may include a carrier structure 814 and a fixed base structure 816. According to some embodiments, the carrier structure 814 may be attached to the lens group 802. For instance, the carrier structure 814 may be attached to the lens group 802 such that the lens group 802 moves together with the carrier structure 814. In various embodiments, the carrier structure 814 may extend around the first prism 804, the lens group 802, and the second prism 806. The carrier structure 814 may define a periphery within which at least a respective portion of each of the first prism 804, the lens group 802, and the second prism 806 are disposed.

[0071] In some embodiments, the fixed base structure 816 may extend around the carrier structure 814. The fixed base structure 816 may be fixed (or static) relative to movement of the carrier structure 814. The fixed base structure 816 may be spaced apart from the carrier structure 814 to allow for movement (e.g., AF and/or OIS movement) of the carrier structure 814 within a periphery defined by the fixed base structure 816.

[0072] In some embodiments, the actuator arrangement 800 may include one or more voice coil motor (VCM) actuators. For instance, the actuator arrangement 800 may include one or more autofocus (AF) VCM actuators and/or one or more optical image stabilization (OIS) VCM actuators. In some examples, the actuator arrangement 800 may include an AF VCM actuator 818 to provide AF movement, an OIS-X VCM actuator 820 to provide OIS-X movement, and an OIS-Y VCM actuator 822 to provide OIS-Y movement.

[0073] The AF VCM actuator 818 may include one or more magnets and one or more coils. In some examples, the AF VCM actuator 818 may include a pair of AF magnets 824 and an AF coil 826. The AF coil 826 may be electrically driven to magnetically interact with the AF magnets 824 to produce Lorentz forces that move the AF coil 826 the carrier structure 814, and/or the lens group 802 along an axis (e.g., in directions indicated by arrows 830 shown in FIGS. 8B and 8D) to provide AF movement of the lens group 802. The AF magnets 824 may be attached to the fixed base structure 816. The AF coil 826 may be attached to the carrier structure 814. According to some embodiments, the AF coil 826 may extend from the carrier structure 814 such that the AF coil 826 is nested between the AF magnets 824, e.g., as indicated in FIG. 8B. In some cases, the AF coil 826 may be attached to a protrusion 828 of the carrier structure 814, and the protrusion 828 may extend toward the AF magnets 824, e.g., to locate the AF coil 826 within a vertical space between the AF magnets 824. In some instances, the AF coil 826 may be wound around the protrusion 828. In some embodiments, the AF coil 826 may have a long axis that is parallel to respective long axes of the AF magnets 824. In various embodiments, the AF VCM actuator 818 may be tucked within a space under a portion of the first prism 804, e.g., as indicated in FIG. 8B. In this manner, the impact of the AF VCM actuator 818 on the dimension of the system along the system X-axis and along the system Z-axis may be reduced or eliminated.

[0074] In some embodiments, the AF magnets 824 may have opposite poling directions, e.g., as indicate in FIG. 8B by arrows 832. Furthermore, the AF magnets 824 may produce respective magnetic fields as indicated in FIG. 8B by magnetic field arrows 834. An example direction of current flow through the AF coil 826 is indicated in FIG. 8B

using a cross (X) and a dot (•). The cross indicates current flowing “into the page,” and the dot indicates current flowing “out of the page.” This “cross and dot” convention for indicating example directions of current flow through coils is maintained throughout this disclosure.

[0075] In various embodiments, the AF coil **826** may be located within components of the magnetic fields produced by the AF magnets **824** that remain substantially constant in direction along a stroke of the AF coil **826**.

[0076] The OIS-X VCM actuator **820** may include one or more magnets and one or more coils. In some examples, the OIS-X VCM actuator **820** may include a pair of OIS-X magnets **836** and an OIS-X coil **838**. The OIS-X coil **838** may be electrically driven to magnetically interact with the OIS-X magnets **836** to produce Lorentz forces that move the OIS-X coil **838**, the carrier structure **814**, and/or the lens group **802** along an axis (e.g., in directions indicated by arrows **840** shown in FIGS. **8B** and **8D**) to provide OIS-X movement of the lens group **802**. The OIS-X magnets **836** may be attached to the fixed base structure **816**. The OIS-X coil **838** may be attached to the carrier structure **814**. According to some embodiments, the OIS-X coil **838** may extend from the carrier structure **814** such that the OIS-X coil **838** is nested between the OIS-X magnets **836**, e.g., as indicated in FIG. **8B**. In some cases, the OIS-X coil **838** may be attached to a protrusion **842** of the carrier structure **814**, and the protrusion **842** may extend toward the OIS-X magnets **836**, e.g., to locate the OIS-X coil **838** within a horizontal space between the OIS-X magnets **836**. In some instances, the OIS-X coil **838** may be wound around the protrusion **842**. In some embodiments, the OIS-X coil **838** may have a long axis that is parallel to respective long axes of the OIS-X magnets **836**.

[0077] In some embodiments, the OIS-X magnets **836** may have opposite poling directions, e.g., as indicate in FIG. **8B** by arrows **844**. Furthermore, the OIS-X magnets **836** may produce respective magnetic fields as indicated in FIG. **8B** by magnetic field arrows **846**.

[0078] In various embodiments, the OIS-X coil **838** may be located within components of the magnetic fields produced by the OIS-X magnets **836** that remain substantially constant in direction along a stroke of the OIS-X coil **838**.

[0079] The OIS-Y VCM actuator **822** may include one or more magnets and one or more coils. In some examples, the OIS-Y VCM actuator **822** may include a pair of OIS-Y magnets **848** and an OIS-Y coil **850** to a first side of the lens group **802**, and another pair of OIS-Y magnets **848** and another OIS-Y coil **850** to a second side of the lens group **802** that is opposite the first side. The OIS-Y coils **850** may be electrically driven to magnetically interact with the OIS-Y magnets **848** to produce Lorentz forces that move the OIS-Y coils **850**, the carrier structure **814**, and/or the lens group **802** along an axis (e.g., in directions indicated by arrows **852** shown in FIGS. **8C** and **8D**) to provide OIS-Y movement of the lens group **802**. The OIS-Y magnets **848** may be attached to the fixed base structure **816**. The OIS-Y coils **850** may be attached to the carrier structure **814**. According to some embodiments, the OIS-Y coils **850** may extend from the carrier structure **814** such that respective OIS-Y coils **850** are nested between respective pairs of OIS-Y magnets **848**. In some cases, each of the OIS-Y coils **850** may be attached to a respective protrusion **854** of the carrier structure **814**, and the respective protrusion **854** may extend toward a respective pair of OIS-Y magnets **848**. In

some instances, each of the OIS-Y coils **850** may be wound around a respective protrusion **854**. In some embodiments, each of the OIS-Y coils **850** may have a respective long axis that is parallel to respective long axes of the OIS-Y magnets **848**.

[0080] In some embodiments, the OIS-Y magnets **848** may have opposite poling directions, e.g., as indicate in FIG. **8B** by arrows **856**. Furthermore, the OIS-Y magnets **848** may produce respective magnetic fields as indicated in FIG. **8B** by magnetic field arrows **858**.

[0081] In various embodiments, the OIS-Y coils **850** may be located within components of the magnetic fields produced by the OIS-Y magnets **848** that remain substantially constant in direction along respective strokes of the OIS-Y coils **850**.

[0082] FIGS. **9A-9C** illustrate schematic side, top, and cross-sectional views, respectively, of an example actuator arrangement **900** for 3-axis shifting of a lens group within a folded optics arrangement of a camera. The actuator arrangement **900** may be the same as, or similar to, the actuator arrangement **800** discussed above with reference to FIGS. **8A-8D**. In FIGS. **9A-9C**, arrows on the coils (e.g., Lorentz forces produced as a result of magnetic interaction between the coils and the magnets) and/or example directions of movement based on forces acting on the coils. Furthermore, arrows on the magnets may represent example poling directions of the magnets. These arrow conventions also apply to coils and magnets in FIGS. **10A-13C**.

[0083] In various embodiments, the camera may include a lens group **902**, a first prism **904**, and a second prism **906**. The lens group **902** may include one or more lens elements **908** disposed within a lens holder. In various embodiments, the camera may include a carrier structure **910** and a fixed base structure **912**. In some embodiments, the actuator arrangement **900** may include an AF VCM actuator **914** to provide AF movement, an OIS-X VCM actuator **916** to provide OIS-X movement, and an OIS-Y VCM actuator **918** to provide OIS-Y movement.

[0084] While some actuator arrangements described above may include an OIS-X VCM actuator located below the lens group, in some embodiments an actuator arrangement may include OIS-X VCM actuators located in corners of the camera system instead of below the lens group. For example, FIGS. **10A-10C** each illustrate a respective schematic view of an example actuator arrangement **1000** (e.g., for 3-axis shifting of a lens group within a folded optics arrangement of a camera) that may include such corner OIS-X VCM actuators. FIG. **10A** shows a schematic side view of the actuator arrangement **1000**. FIG. **10B** shows a schematic top view of the actuator arrangement **1000**. FIG. **10C** shows a schematic cross-sectional view of the actuator arrangement **1000**.

[0085] In various embodiments, the camera may include a lens group **1002**, a first prism **1004**, and a second prism **1006**. The lens group **1002** may include one or more lens elements disposed within a lens holder. In various embodiments, the camera may include a carrier structure **1008** and a fixed base structure **1010**.

[0086] In some embodiments, the actuator arrangement **1000** may include an AF VCM actuator **1012** to provide AF movement. The AF VCM actuator **1012** may be configured like the AF VCM actuator **818** described above with reference to FIGS. **8A-8D**.

[0087] In some embodiments, the actuator arrangement 1000 may include an OIS-Y VCM actuator 1014 to provide OIS-Y movement. The OIS-Y VCM actuator 1014 may be configured like the OIS-Y VCM actuator 822 described above with reference to FIGS. 8A-8D.

[0088] As mentioned above, the actuator arrangement 1000 may include corner OIS-X VCM actuators 1016. Rather than a single OIS-X VCM actuator being located below the lens group 1002 (e.g., as described above with reference to FIGS. 8A-8D), the corner OIS-X VCM actuators 1016 do not impact, or minimally impact, the dimension of the system along the system Z-axis. As shown in FIG. 10B, the actuator arrangement 1000 may include four corner OIS-X VCM actuators 1016 in some embodiments—each corner OIS-X VCM actuator 1016 being disposed proximate a respective corner of the carrier structure 1008 and/or the fixed base structure 1010.

[0089] As indicated in FIG. 10C, each corner OIS-X VCM actuator 1016 may include a pair of OIS-X magnets 1018 and an OIS-X coil 1020. The OIS-X magnets 1018 may be coupled to the fixed base structure 1010. In some examples, a first protrusion 1022 may extend from the fixed base structure 1010 towards the carrier structure 1008. The first protrusion 1022 may be part of the fixed base structure 1010 in some embodiments. In some embodiments, the first protrusion 1022 may be a structure that is attached to the fixed base structure 1010. One or both of the OIS-X magnets 1018 may be attached to or otherwise supported by the first protrusion 1022 and/or the fixed base structure 1010, e.g., as indicated in FIG. 10C. The OIS-X coil may be coupled to the carrier structure 1008. In some examples, a second protrusion 1024 may extend from the carrier structure 1008 towards the fixed base structure 1010 and towards the OIS-X magnets 1018. The OIS-X coil 1020 may be attached to an end portion of the second protrusion 1024 such that the OIS-X coil 1020 is located within a horizontal space between the OIS-X magnets 1018. That is, the OIS-X coil 1020 may be nested between the OIS-X magnets 1018.

[0090] In some actuator arrangements, corner OIS-X VCM actuators may comprise dual pole OIS-X magnets. For example, FIGS. 11A-11C each illustrate a respective schematic view of an example actuator arrangement 1100 (e.g., for 3-axis shifting of a lens group within a folded optics arrangement of a camera) that may include corner OIS-X VCM actuators having dual pole OIS-X magnets. FIG. 11A shows a schematic side view of the actuator arrangement 1100. FIG. 11B shows a schematic top view of the actuator arrangement 1100. FIG. 11C shows a schematic cross-sectional view of the actuator arrangement 1100.

[0091] In various embodiments, the camera may include a lens group 1102, a first prism 1104, and a second prism 1106. The lens group 1102 may include one or more lens elements disposed within a lens holder. In various embodiments, the camera may include a carrier structure 1108 and a fixed base structure 1110.

[0092] In some embodiments, the actuator arrangement 1100 may include an AF VCM actuator 1112 to provide AF movement. The AF VCM actuator 1112 may be configured like the AF VCM actuator 818 described above with reference to FIGS. 8A-8D.

[0093] In some embodiments, the actuator arrangement 1100 may include an OIS-Y VCM actuator 1114 to provide OIS-Y movement. The OIS-Y VCM actuator 1114 may be

configured like the OIS-Y VCM actuator 822 described above with reference to FIGS. 8A-8D.

[0094] In some embodiments, the actuator arrangement 1100 may include corner OIS-X VCM actuators 1116. Rather than a single OIS-X VCM actuator being located below the lens group 1102 (e.g., as described above with reference to FIGS. 8A-8D), the corner OIS-X VCM actuators 1116 do not impact, or minimally impact, the dimension of the system along the system Z-axis. As shown in FIG. 11B, the actuator arrangement 1100 may include four corner OIS-X VCM actuators 1116 in some embodiments—each corner OIS-X VCM actuator 1116 being disposed proximate a respective corner of the carrier structure 1108 and/or the fixed base structure 1110.

[0095] As indicated in FIG. 11C, each corner OIS-X VCM actuator 1116 may include a pair of dual pole OIS-X magnets 1118 and an OIS-X coil 1120. The dual pole OIS-X magnets 1118 may be coupled to the fixed base structure 1110, e.g., as indicated in FIG. 11C. In some examples, the dual pole OIS-X magnets may be aligned along a vertical plane. In some embodiments, the OIS-X coil 1120 may be coupled to the carrier structure 1108. According to some examples, a protrusion 1122 may extend from the carrier structure 1108 towards the fixed base structure 1110 and towards the dual pole OIS-X magnets 1118. The OIS-X coil 1120 may be attached to an end portion of the protrusion 1122 such that the OIS-X coil 1120 is located proximate the dual pole OIS-X magnets 1118. In the actuator arrangement 1100, the OIS-X coil 1120 may not be nested between the dual pole OIS-X magnets 1118. As such, in some instances the OIS-X coils 1120 on one side of the system may move away from their corresponding dual pole OIS-X magnets 1118. Components of the magnetic fields produced by the corresponding dual pole OIS-X magnets 1118 may increasingly vary in direction as the OIS-X coils 1120 move away from the magnets. Accordingly, one or more of the corner OIS-X VCM actuators 1116 may be independently controlled in some embodiments. For instance, a first pair of corner OIS-X VCM actuators 1116 at a first side of the carrier structure 1108 may be controlled independently of a second pair of corner OIS-X VCM actuators 1116 at a second side of the carrier structure 1108 opposite the first side of the carrier structure 1108.

[0096] As mentioned above, various actuator arrangements may include an OIS-X VCM actuator located below the lens group (e.g., as indicated in the actuator arrangements described above with reference to FIGS. 8A-9C) or corner OIS-X VCM actuators located at corners of the camera system (e.g., as indicated in the actuator arrangements described above with reference to FIGS. 10A-11C). In some embodiments, an actuator arrangement may instead include one or more OIS-X VCM actuators behind the first prism and/or in front of the second prism. For example, FIGS. 12A-12C each illustrate a respective schematic view of an example actuator arrangement 1200 (e.g., for 3-axis shifting of a lens group within a folded optics arrangement of a camera) that may include such OIS-X VCM actuators. FIG. 12A shows a schematic side view of the actuator arrangement 1200. FIG. 12B shows a schematic top view of the actuator arrangement 1200. FIG. 12C shows a schematic cross-sectional view of the actuator arrangement 1200.

[0097] In various embodiments, the camera may include a lens group 1202, a first prism 1204, and a second prism 1206. The lens group 1202 may include one or more lens

elements disposed within a lens holder. In various embodiments, the camera may include a carrier structure **1208** and a fixed base structure **1210**.

[0098] In some embodiments, the actuator arrangement **1200** may include an AF VCM actuator **1212** to provide AF movement. The AF VCM actuator **1212** may be configured like the AF VCM actuator **818** described above with reference to FIGS. **8A-8D**. In some embodiments, at least a portion of the AF VCM actuator **1212** may not be tucked under the first prism **1204**, e.g., as indicated in FIG. **12C**.

[0099] In some embodiments, the actuator arrangement **1200** may include an OIS-Y VCM actuator **1214** to provide OIS-Y movement. The OIS-Y VCM actuator **1214** may be configured like the OIS-Y VCM actuator **822** described above with reference to FIGS. **8A-8D**.

[0100] In some embodiments, the actuator arrangement **1200** may include OIS-X VCM actuators **1216** to provide OIS-X movement. For instance, the actuator arrangement **1200** may include a first OIS-X VCM actuator **1216** below the first prism **1204**, e.g., as indicated in FIGS. **12A** and **12C**. Furthermore, the actuator arrangement **1200** may include a second OIS-X VCM actuator **1216** proximate the second prism **1206**, e.g., as indicated in FIGS. **12A-12C**. Each of the OIS-X VCM actuators **1216** may include a pair of OIS-X magnets **1218** and an OIS-X coil **1220**. The OIS-X magnets **1218** may be coupled to the fixed base structure **1210**, and the OIS-X coil **1220** may be coupled to the carrier structure **1208**. In various embodiments, the OIS-X coil **1220** may be nested between the OIS-X magnets **1218**.

[0101] While some actuator arrangements described above may include a respective magnet for each VCM actuator, in some embodiments an actuator arrangement may include one or more magnets that may be shared by multiple VCM actuators. For example, FIGS. **13A-13C** each illustrate a respective schematic view of an example actuator arrangement **1300** (e.g., for 3-axis shifting of a lens group within a folded optics arrangement of a camera) that may include such shared magnets. FIG. **13A** shows a schematic side view of the actuator arrangement **1300**. FIG. **13B** shows a schematic top view of the actuator arrangement **1300**. FIG. **13C** shows a schematic cross-sectional view of the actuator arrangement **1300**.

[0102] In various embodiments, the camera may include a lens group **1302**, a first prism **1304**, and a second prism **1306**. The lens group **1302** may include one or more lens elements disposed within a lens holder. In various embodiments, the camera may include a carrier structure **1308** and a fixed base structure **1310**.

[0103] In some embodiments, the actuator arrangement **1300** may include an AF VCM actuator **1312** to provide AF movement. The AF VCM actuator **1312** may be configured like the AF VCM actuator **818** described above with reference to FIGS. **8A-8D**.

[0104] In some embodiments, the actuator arrangement **1300** may include an OIS-Y VCM actuator **1314** to provide OIS-Y movement. Furthermore, the actuator arrangement **1300** may include OIS-X VCM actuators **1316** to provide OIS-X movement. In some examples, the OIS-Y VCM actuator **1314** and the OIS-X VCM actuators **1316** may share magnets, e.g., as shown in FIG. **13C**. In some embodiments, the OIS-Y VCM actuator **1314** may share a first magnet **1318** with a first OIS-X VCM actuator **1316**, and the OIS-Y VCM actuator **1314** may share a second magnet **1320** with a second OIS-X VCM actuator **1316** opposite the first

OIS-X VCM actuator with respect to the carrier structure **1308**. The magnets **1318**, **1320** may be coupled to the fixed base structure **1310**. Each of the OIS-X VCM actuators **1316** may include a respective OIS-X coil **1322** that is coupled to the carrier structure **1308**. In some examples, the OIS-X coils **1322** may be horizontally-oriented racetrack coils. In some embodiments, each of the OIS-X coils **1322** may be attached to a respective protrusion **1324** that extends from the carrier structure **1308** towards the fixed base structure **1310**.

[0105] In some embodiments, the OIS-Y VCM actuator may include an OIS-Y coil **1326** that is coupled to the carrier structure **1308**. For instance, the OIS-Y coil **1326** may be a horizontally-oriented racetrack coil that is attached to the carrier structure **1308** below the lens group **1302**. Furthermore, the OIS-Y coil **1326** may surround an outer periphery of the lens group **1302** in some examples.

[0106] The camera systems described herein may have various components (e.g., the optical elements, the suspension arrangements, and/or the actuator arrangements, etc.) that are at least partially enclosed by a housing (e.g., a shield can). For example, FIG. **14A** shows a perspective view of an example camera **1400** with a shield can covering at least a portion of the internal components of the camera **1400**. FIG. **14B** shows a perspective view of the camera **1400** without the shield covering the internal components.

[0107] In some embodiments, the camera **1400** may include a lens group **1402** between a first prism **1404** and a second prism **1406**. The lens group **1302** may include one or more lens elements disposed within a lens holder. In various embodiments, the camera **1400** may include a carrier structure **1408** and a fixed base structure **1410**.

[0108] In some embodiments, the first prism **1404** may be held within a first prism holder **1412**. Furthermore, the second prism **1406** may be held within a second prism holder **1414**. The camera **1400** may include a shield can **1416** to which the first prism **1404** may be attached via first prism holder **1412**, and to which the second prism **1406** may be attached via the second prism holder **1414**.

[0109] According to various embodiments, the shield can **1416** may define an aperture **1418** above the first prism **1404** such that light may enter the camera **1400** and reach the first prism **1404**. In some cases, the aperture **1418** may be enclosed and/or sealed, e.g., via a transparent window. As such, dust particles may be prevented from entering the camera through the aperture **1418** and negatively impacting optical performance of the first prism **1404** and/or other components of the camera **1400** in some instances. Although not illustrated in FIGS. **14A** and **14B**, the camera **1400** may include one or more openings configured to allow ventilation.

[0110] In some embodiments, the camera **1400** may include a flex circuit **1420** disposed below the first prism **1404**, the lens group **1402**, the second prism **1406**, the carrier structure **1408**, and/or the fixed base structure **1410**. The flex circuit **1420** may include an interface **1422** configured to allow the camera **1400** to interface with one or more other components external to the camera **1400**. The flex circuit **1420** may be used to convey data signals and electrical power to and from the camera **1400**.

[0111] In some embodiments, the camera **1400** may include a stiffener **1426** at least partially below the flex circuit **1420**. For instance, the stiffener **1426** may be a folded stiffener, e.g., as shown in FIGS. **14A** and **14B**. According to

some examples, the folded stiffener **1426** may include a base portion below the flex circuit **1420** and tab portions that are each folded from the base portion to cover a respective side of the camera **1400** and/or the shield can **1416**. In some cases, the folded stiffener **1426** may include three tab portions, with each tab portion covering a portion of a respective one of three sides of the camera **1400** and/or the shield can **1416**. A fourth side of the camera **1400** and/or the shield can **1416** may not have a corresponding tab portion that covers a portion of it. For instance, the fourth side may be a side at which the flex circuit **1420** extends outwardly to one or more components that are external to the camera **1400**.

[0112] In some embodiments, it may be desirable to distribute the weight of components of a camera system in a manner that avoids undesirable moments (e.g., moments about the center of gravity of the lens group). For example, FIG. **15** illustrates a side cross-sectional view of an example camera **1500** with a folded optics arrangement in which a dense material may be added to provide such weight distribution.

[0113] In some embodiments, the camera **1500** may include a lens group **1502** between a first prism **1504** and a second prism **1506**. The lens group **1502** may include one or more lens elements **1508** disposed within a lens holder **1510**.

[0114] In some embodiments, the first prism **1504** may be held within a first prism holder **1512**. Furthermore, the second prism **1506** may be held within a second prism holder **1514**. The camera **1500** may include a shield can **1516** to which the first prism **1504** may be attached via the first prism holder **1512**. In some examples, a top and/or sides of the first prism holder **1512** may be adhered to the shield can **1516**. Additionally, the second prism **1506** may be attached to the shield can **1516** via the second prism holder **1514**. In some examples, a top and/or sides of the second prism holder **1512** may be adhered to the shield can **1516**.

[0115] In some cases, the center of gravity of the lens group **1502** may be located such that certain actuator arrangements may cause undesirable moments about the center of gravity. In some cases, to counteract such moments, a dense material **1518** may be attached to the lens holder **1510**. For instance, the dense material **1518** may be attached to a top portion of the lens holder **1510**, e.g., as indicated in FIG. **15**. In some embodiments, the dense material **1518** may not be attached to the lens holder **1510**, but rather the dense material **1518** may be part of (e.g., formed integrally with) the lens holder **1510**.

[0116] FIG. **16** is a flow chart of an example method **1600** for assembling a camera with a folded optics arrangement, in accordance with some embodiments.

[0117] At **1602**, the method **1600** may include assembling an actuator module of a camera with a folded optics arrangement. For instance, at **1602a**, magnets and coils of VCM actuators may be aligned or otherwise suitably positioned. In some examples, assembling the actuator module may include, at **1602b**, coupling a carrier structure with a fixed base structure via one or more suspension mechanisms. In some implementations, assembling the actuator module may include, at **1602c**, injecting damping material (e.g., a viscoelastic gel) into one or more pockets, e.g., to at least partially surround one or more suspension wires.

[0118] At **1604**, the method **1600** may include performing active alignment of a lens group of the folded optics arrangement to the carrier structure and affixing the lens group to the

carrier structure when the lens group is in an aligned position. At **1606**, the method **1600** may include performing active alignment of a first prism and/or a second prism of the folded optics arrangement to a shield can and affixing the prisms to the shield can when the prisms are in aligned positions. It should be understood that the active alignment with respect to the lens group may be performed before, after, or contemporaneously with the active alignment performed with respect to the prisms.

[0119] At **1608**, the method **1600** may include attaching the shield can to the assembled actuator module. At **1610**, the method **1600** may include attaching a substrate that is coupled with an image sensor to the actuator module. At **1612**, the method **1600** may include attaching a stiffener to the actuator module.

#### Multifunction Device Examples

[0120] Embodiments of electronic devices, user interfaces for such devices, and associated processes for using such devices are described. In some embodiments, the device is a portable communications device, such as a mobile telephone, that also contains other functions, such as PDA and/or music player functions. Example embodiments of portable multifunction devices include, without limitation, the iPhone®, iPod Touch®, and iPad® devices from Apple Inc. of Cupertino, California. Other portable electronic devices, such as laptops, cameras, cell phones, or tablet computers, may also be used. It should also be understood that, in some embodiments, the device is not a portable communications device, but is a desktop computer with a camera. In some embodiments, the device is a gaming computer with orientation sensors (e.g., orientation sensors in a gaming controller). In other embodiments, the device is not a portable communications device, but is a camera.

[0121] In the discussion that follows, an electronic device that includes a display and a touch-sensitive surface is described. It should be understood, however, that the electronic device may include one or more other physical user-interface devices, such as a physical keyboard, a mouse and/or a joystick.

[0122] The device typically supports a variety of applications, such as one or more of the following: a drawing application, a presentation application, a word processing application, a website creation application, a disk authoring application, a spreadsheet application, a gaming application, a telephone application, a video conferencing application, an e-mail application, an instant messaging application, a work-out support application, a photo management application, a digital camera application, a digital video camera application, a web browsing application, a digital music player application, and/or a digital video player application.

[0123] The various applications that may be executed on the device may use at least one common physical user-interface device, such as the touch-sensitive surface. One or more functions of the touch-sensitive surface as well as corresponding information displayed on the device may be adjusted and/or varied from one application to the next and/or within a respective application. In this way, a common physical architecture (such as the touch-sensitive surface) of the device may support the variety of applications with user interfaces that are intuitive and transparent to the user.

[0124] Attention is now directed toward embodiments of portable devices with cameras. FIG. **17** illustrates a block



diagram of an example portable multifunction device **1700** that may include one or more cameras (e.g., the cameras described above with reference to FIGS. **1-16**), in accordance with some embodiments. Cameras **1764** are sometimes called “optical sensors” for convenience, and may also be known as or called an optical sensor system. Device **1700** may include memory **1702** (which may include one or more computer readable storage mediums), memory controller **1722**, one or more processing units (CPUs) **1720**, peripherals interface **1718**, RF circuitry **1708**, audio circuitry **1710**, speaker **1711**, touch-sensitive display system **1712**, microphone **1713**, input/output (I/O) subsystem **1706**, other input or control devices **1716**, and external port **1724**. Device **1700** may include multiple optical sensors **1764**. These components may communicate over one or more communication buses or signal lines **1703**.

[0125] It should be appreciated that device **1700** is only one example of a portable multifunction device, and that device **1700** may have more or fewer components than shown, may combine two or more components, or may have a different configuration or arrangement of the components. The various components shown in FIG. **17** may be implemented in hardware, software, or a combination of hardware and software, including one or more signal processing and/or application specific integrated circuits.

[0126] Memory **1702** may include high-speed random access memory and may also include non-volatile memory, such as one or more magnetic disk storage devices, flash memory devices, or other non-volatile solid-state memory devices. Access to memory **1702** by other components of device **1700**, such as CPU **1720** and the peripherals interface **1718**, may be controlled by memory controller **1722**.

[0127] Peripherals interface **1718** can be used to couple input and output peripherals of the device to CPU **1720** and memory **1702**. The one or more processors **1720** run or execute various software programs and/or sets of instructions stored in memory **1702** to perform various functions for device **1700** and to process data.

[0128] In some embodiments, peripherals interface **1718**, CPU **1720**, and memory controller **1722** may be implemented on a single chip, such as chip **1704**. In some other embodiments, they may be implemented on separate chips.

[0129] RF (radio frequency) circuitry **1708** receives and sends RF signals, also called electromagnetic signals. RF circuitry **1708** converts electrical signals to/from electromagnetic signals and communicates with communications networks and other communications devices via the electromagnetic signals. RF circuitry **1708** may include well-known circuitry for performing these functions, including but not limited to an antenna system, an RF transceiver, one or more amplifiers, a tuner, one or more oscillators, a digital signal processor, a CODEC chipset, a subscriber identity module (SIM) card, memory, and so forth. RF circuitry **1708** may communicate with networks, such as the Internet, also referred to as the World Wide Web (WWW), an intranet and/or a wireless network, such as a cellular telephone network, a wireless local area network (LAN) and/or a metropolitan area network (MAN), and other devices by wireless communication. The wireless communication may use any of a variety of communications standards, protocols and technologies, including but not limited to Global System for Mobile Communications (GSM), Enhanced Data GSM Environment (EDGE), high-speed downlink packet access (HSDPA), high-speed uplink packet access (HSUPA), wide-

band code division multiple access (W-CDMA), code division multiple access (CDMA), time division multiple access (TDMA), Bluetooth, Wireless Fidelity (Wi-Fi) (e.g., IEEE 802.11a, IEEE 802.11b, IEEE 802.11g and/or IEEE 802.11n), voice over Internet Protocol (VOIP), Wi-MAX, a protocol for e-mail (e.g., Internet message access protocol (IMAP) and/or post office protocol (POP)), instant messaging (e.g., extensible messaging and presence protocol (XMPP), Session Initiation Protocol for Instant Messaging and Presence Leveraging Extensions (SIMPLE), Instant Messaging and Presence Service (IMPS)), and/or Short Message Service (SMS), or any other suitable communication protocol, including communication protocols not yet developed as of the filing date of this document.

[0130] Audio circuitry **1710**, speaker **1711**, and microphone **1713** provide an audio interface between a user and device **1700**. Audio circuitry **1710** receives audio data from peripherals interface **1718**, converts the audio data to an electrical signal, and transmits the electrical signal to speaker **1711**. Speaker **1711** converts the electrical signal to human-audible sound waves. Audio circuitry **1710** also receives electrical signals converted by microphone **1713** from sound waves. Audio circuitry **1710** converts the electrical signal to audio data and transmits the audio data to peripherals interface **1718** for processing. Audio data may be retrieved from and/or transmitted to memory **1702** and/or RF circuitry **1708** by peripherals interface **1718**. In some embodiments, audio circuitry **1710** also includes a headset jack (e.g., **1812**, FIG. **18**). The headset jack provides an interface between audio circuitry **1710** and removable audio input/output peripherals, such as output-only headphones or a headset with both output (e.g., a headphone for one or both ears) and input (e.g., a microphone).

[0131] I/O subsystem **1706** couples input/output peripherals on device **1700**, such as touch screen **1712** and other input control devices **1716**, to peripherals interface **1718**. I/O subsystem **1706** may include display controller **1756** and one or more input controllers **1760** for other input or control devices. The one or more input controllers **1760** receive/send electrical signals from/to other input or control devices **1716**. The other input control devices **1716** may include physical buttons (e.g., push buttons, rocker buttons, etc.), dials, slider switches, joysticks, click wheels, and so forth. In some alternate embodiments, input controller(s) **1760** may be coupled to any (or none) of the following: a keyboard, infrared port, USB port, and a pointer device such as a mouse. The one or more buttons (e.g., **1208**, FIG. **12**) may include an up/down button for volume control of speaker **1711** and/or microphone **1713**. The one or more buttons may include a push button (e.g., **1806**, FIG. **18**).

[0132] Touch-sensitive display **1712** provides an input interface and an output interface between the device and a user. Display controller **1756** receives and/or sends electrical signals from/to touch screen **1712**. Touch screen **1712** displays visual output to the user. The visual output may include graphics, text, icons, video, and any combination thereof (collectively termed “graphics”). In some embodiments, some or all of the visual output may correspond to user-interface objects.

[0133] Touch screen **1712** has a touch-sensitive surface, sensor or set of sensors that accepts input from the user based on haptic and/or tactile contact. Touch screen **1712** and display controller **1756** (along with any associated modules and/or sets of instructions in memory **1702**) detect

contact (and any movement or breaking of the contact) on touch screen 1712 and converts the detected contact into interaction with user-interface objects (e.g., one or more soft keys, icons, web pages or images) that are displayed on touch screen 1712. In an example embodiment, a point of contact between touch screen 1712 and the user corresponds to a finger of the user.

[0134] Touch screen 1712 may use LCD (liquid crystal display) technology, LPD (light emitting polymer display) technology, or LED (light emitting diode) technology, although other display technologies may be used in other embodiments. Touch screen 1712 and display controller 1756 may detect contact and any movement or breaking thereof using any of a variety of touch sensing technologies now known or later developed, including but not limited to capacitive, resistive, infrared, and surface acoustic wave technologies, as well as other proximity sensor arrays or other elements for determining one or more points of contact with touch screen 1712. In an example embodiment, projected mutual capacitance sensing technology is used, such as that found in the iPhone®, iPod Touch®, and iPad® from Apple Inc. of Cupertino, California.

[0135] Touch screen 1712 may have a video resolution in excess of 800 dpi. In some embodiments, the touch screen has a video resolution of approximately 860 dpi. The user may make contact with touch screen 1712 using any suitable object or appendage, such as a stylus, a finger, and so forth. In some embodiments, the user interface is designed to work primarily with finger-based contacts and gestures, which can be less precise than stylus-based input due to the larger area of contact of a finger on the touch screen. In some embodiments, the device translates the rough finger-based input into a precise pointer/cursor position or command for performing the actions desired by the user.

[0136] In some embodiments, in addition to the touch screen, device 1700 may include a touchpad (not shown) for activating or deactivating particular functions. In some embodiments, the touchpad is a touch-sensitive area of the device that, unlike the touch screen, does not display visual output. The touchpad may be a touch-sensitive surface that is separate from touch screen 1712 or an extension of the touch-sensitive surface formed by the touch screen.

[0137] Device 1700 also includes power system 1762 for powering the various components. Power system 1762 may include a power management system, one or more power sources (e.g., battery, alternating current (AC)), a recharging system, a power failure detection circuit, a power converter or inverter, a power status indicator (e.g., a light-emitting diode (LED)) and any other components associated with the generation, management and distribution of power in portable devices.

[0138] Device 1700 may also include one or more optical sensors or cameras 1764. FIG. 17 shows an optical sensor 1764 coupled to optical sensor controller 1758 in I/O subsystem 1706. Optical sensor 1764 may include charge-coupled device (CCD) or complementary metal-oxide semiconductor (CMOS) phototransistors. Optical sensor 1764 receives light from the environment, projected through one or more lens, and converts the light to data representing an image. In conjunction with imaging module 1743 (also called a camera module), optical sensor 1764 may capture still images or video. In some embodiments, an optical sensor 1764 is located on the back of device 1700, opposite touch screen display 1712 on the front of the device, so that

the touch screen display 1712 may be used as a viewfinder for still and/or video image acquisition. In some embodiments, another optical sensor is located on the front of the device so that the user's image may be obtained for video-conferencing while the user views the other video conference participants on the touch screen display.

[0139] Device 1700 may also include one or more proximity sensors 1766. FIG. 17 shows proximity sensor 1766 coupled to peripherals interface 1718. Alternately, proximity sensor 1766 may be coupled to input controller 1760 in I/O subsystem 1706. In some embodiments, the proximity sensor 1766 turns off and disables touch screen 1712 when the multifunction device 1700 is placed near the user's ear (e.g., when the user is making a phone call).

[0140] Device 1700 includes one or more orientation sensors 1768. In some embodiments, the one or more orientation sensors 1768 include one or more accelerometers (e.g., one or more linear accelerometers and/or one or more rotational accelerometers). In some embodiments, the one or more orientation sensors 1768 include one or more gyroscopes. In some embodiments, the one or more orientation sensors 1768 include one or more magnetometers. In some embodiments, the one or more orientation sensors 1768 include one or more global positioning system (GPS), Global Navigation Satellite System (GLONASS), and/or other global navigation system receivers. The GPS, GLONASS, and/or other global navigation system receivers may be used for obtaining information concerning the location and orientation (e.g., portrait or landscape) of device 1700. In some embodiments, the one or more orientation sensors 1768 include any combination of orientation/rotation sensors. FIG. 17 shows the one or more orientation sensors 1768 coupled to peripherals interface 1718. Alternately, the one or more orientation sensors 1768 may be coupled to an input controller 1760 in I/O subsystem 1706. In some embodiments, information is displayed on the touch screen display 1712 in a portrait view or a landscape view based on an analysis of data received from the one or more orientation sensors 1768.

[0141] In some embodiments, the software components stored in memory 1702 include operating system 1726, communication module (or set of instructions) 1728, contact/motion module (or set of instructions) 1730, graphics module (or set of instructions) 1732, text input module (or set of instructions) 1734, Global Positioning System (GPS) module (or set of instructions) 1735, arbiter module 1758 and applications (or sets of instructions) 1736. Furthermore, in some embodiments memory 1702 stores device/global internal state 1757. Device/global internal state 1757 includes one or more of: active application state, indicating which applications, if any, are currently active; display state, indicating what applications, views or other information occupy various regions of touch screen display 1712; sensor state, including information obtained from the device's various sensors and input control devices 1716; and location information concerning the device's location and/or attitude.

[0142] Operating system 1726 (e.g., Darwin, RTXC, LINUX, UNIX, OS X, WINDOWS, or an embedded operating system such as VxWorks) includes various software components and/or drivers for controlling and managing general system tasks (e.g., memory management, storage device control, power management, etc.) and facilitates communication between various hardware and software components.

[0143] Communication module 1728 facilitates communication with other devices over one or more external ports 1724 and also includes various software components for handling data received by RF circuitry 1708 and/or external port 1724. External port 1724 (e.g., Universal Serial Bus (USB), FIREWIRE, etc.) is adapted for coupling directly to other devices or indirectly over a network (e.g., the Internet, wireless LAN, etc.). In some embodiments, the external port is a multi-pin (e.g., 30-pin) connector.

[0144] Contact/motion module 1730 may detect contact with touch screen 1712 (in conjunction with display controller 1756) and other touch sensitive devices (e.g., a touchpad or physical click wheel). Contact/motion module 1730 includes various software components for performing various operations related to detection of contact, such as determining if contact has occurred (e.g., detecting a finger-down event), determining if there is movement of the contact and tracking the movement across the touch-sensitive surface (e.g., detecting one or more finger-dragging events), and determining if the contact has ceased (e.g., detecting a finger-up event or a break in contact). Contact/motion module 1730 receives contact data from the touch-sensitive surface. Determining movement of the point of contact, which is represented by a series of contact data, may include determining speed (magnitude), velocity (magnitude and direction), and/or an acceleration (a change in magnitude and/or direction) of the point of contact. These operations may be applied to single contacts (e.g., one finger contacts) or to multiple simultaneous contacts (e.g., “multitouch”/multiple finger contacts). In some embodiments, contact/motion module 1730 and display controller 1756 detect contact on a touchpad.

[0145] Contact/motion module 1730 may detect a gesture input by a user. Different gestures on the touch-sensitive surface have different contact patterns. Thus, a gesture may be detected by detecting a particular contact pattern. For example, detecting a finger tap gesture includes detecting a finger-down event followed by detecting a finger-up (lift off) event at the same position (or substantially the same position) as the finger-down event (e.g., at the position of an icon). As another example, detecting a finger swipe gesture on the touch-sensitive surface includes detecting a finger-down event followed by detecting one or more finger-dragging events, and subsequently followed by detecting a finger-up (lift off) event.

[0146] Graphics module 1732 includes various known software components for rendering and displaying graphics on touch screen 1712 or other display, including components for changing the intensity of graphics that are displayed. As used herein, the term “graphics” includes any object that can be displayed to a user, including without limitation text, web pages, icons (such as user-interface objects including soft keys), digital images, videos, animations and the like.

[0147] In some embodiments, graphics module 1732 stores data representing graphics to be used. Each graphic may be assigned a corresponding code. Graphics module 1732 receives, from applications etc., one or more codes specifying graphics to be displayed along with, if necessary, coordinate data and other graphic property data, and then generates screen image data to output to display controller 1756.

[0148] Text input module 1734, which may be a component of graphics module 1732, provides soft keyboards for

entering text in various applications (e.g., contacts 1737, e-mail 1740, IM 1741, browser 1747, and any other application that needs text input).

[0149] GPS module 1735 determines the location of the device and provides this information for use in various applications (e.g., to telephone 1738 for use in location-based dialing, to camera 1743 as picture/video metadata, and to applications that provide location-based services such as weather widgets, local yellow page widgets, and map/navigation widgets).

[0150] Applications 1736 may include the following modules (or sets of instructions), or a subset or superset thereof:

[0151] contacts module 1737 (sometimes called an address book or contact list);

[0152] telephone module 1738;

[0153] video conferencing module 1739;

[0154] e-mail client module 1740;

[0155] instant messaging (IM) module 1741;

[0156] workout support module 1742;

[0157] camera module 1743 for still and/or video images;

[0158] image management module 1744;

[0159] browser module 1747;

[0160] calendar module 1748;

[0161] widget modules 1749, which may include one or more of: weather widget 1749-1, stocks widget 1749-2, calculator widget 1749-3, alarm clock widget 1749-4, dictionary widget 1749-5, and other widgets obtained by the user, as well as user-created widgets 1749-6;

[0162] widget creator module 1750 for making user-created widgets 1749-6;

[0163] search module 1751;

[0164] video and music player module 1752, which may be made up of a video player module and a music player module;

[0165] notes module 1753;

[0166] map module 1754; and/or

[0167] online video module 1755.

[0168] Examples of other applications 1736 that may be stored in memory 1702 include other word processing applications, other image editing applications, drawing applications, presentation applications, JAVA-enabled applications, encryption, digital rights management, voice recognition, and voice replication.

[0169] In conjunction with touch screen 1712, display controller 1756, contact module 1730, graphics module 1732, and text input module 1734, contacts module 1737 may be used to manage an address book or contact list (e.g., stored in application internal state 1757), including: adding name(s) to the address book; deleting name(s) from the address book; associating telephone number(s), e-mail address(es), physical address(es) or other information with a name; associating an image with a name; categorizing and sorting names; providing telephone numbers or e-mail addresses to initiate and/or facilitate communications by telephone 1738, video conference 1739, e-mail 1740, or IM 1741; and so forth.

[0170] In conjunction with RF circuitry 1708, audio circuitry 1710, speaker 1711, microphone 1713, touch screen 1712, display controller 1756, contact module 1730, graphics module 1732, and text input module 1734, telephone module 1738 may be used to enter a sequence of characters corresponding to a telephone number, access one or more telephone numbers in address book 1737, modify a tele-

phone number that has been entered, dial a respective telephone number, conduct a conversation and disconnect or hang up when the conversation is completed. As noted above, the wireless communication may use any of a variety of communications standards, protocols and technologies.

[0171] In conjunction with RF circuitry 1708, audio circuitry 1710, speaker 1711, microphone 1713, touch screen 1712, display controller 1756, optical sensor 1764, optical sensor controller 1758, contact module 1730, graphics module 1732, text input module 1734, contact list 1737, and telephone module 1738, videoconferencing module 1739 includes executable instructions to initiate, conduct, and terminate a video conference between a user and one or more other participants in accordance with user instructions.

[0172] In conjunction with RF circuitry 1708, touch screen 1712, display controller 1756, contact module 1730, graphics module 1732, and text input module 1734, e-mail client module 1740 includes executable instructions to create, send, receive, and manage e-mail in response to user instructions. In conjunction with image management module 1744, e-mail client module 1740 makes it very easy to create and send e-mails with still or video images taken with camera module 1743.

[0173] In conjunction with RF circuitry 1708, touch screen 1712, display controller 1756, contact module 1730, graphics module 1732, and text input module 1734, the instant messaging module 1741 includes executable instructions to enter a sequence of characters corresponding to an instant message, to modify previously entered characters, to transmit a respective instant message (for example, using a Short Message Service (SMS) or Multimedia Message Service (MMS) protocol for telephony-based instant messages or using XMPP, SIMPLE, or IMPS for Internet-based instant messages), to receive instant messages and to view received instant messages. In some embodiments, transmitted and/or received instant messages may include graphics, photos, audio files, video files and/or other attachments as are supported in a MMS and/or an Enhanced Messaging Service (EMS). As used herein, "instant messaging" refers to both telephony-based messages (e.g., messages sent using SMS or MMS) and Internet-based messages (e.g., messages sent using XMPP, SIMPLE, or IMPS).

[0174] In conjunction with RF circuitry 1708, touch screen 1712, display controller 1756, contact module 1730, graphics module 1732, text input module 1734, GPS module 1735, map module 1754, and music player module 1746, workout support module 1742 includes executable instructions to create workouts (e.g., with time, distance, and/or calorie burning goals); communicate with workout sensors (sports devices); receive workout sensor data; calibrate sensors used to monitor a workout; select and play music for a workout; and display, store and transmit workout data.

[0175] In conjunction with touch screen 1712, display controller 1756, optical sensor(s) 1764, optical sensor controller 1758, contact module 1730, graphics module 1732, and image management module 1744, camera module 1743 includes executable instructions to capture still images or video (including a video stream) and store them into memory 1702, modify characteristics of a still image or video, or delete a still image or video from memory 1702.

[0176] In conjunction with touch screen 1712, display controller 1756, contact module 1730, graphics module 1732, text input module 1734, and camera module 1743, image management module 1744 includes executable

instructions to arrange, modify (e.g., edit), or otherwise manipulate, label, delete, present (e.g., in a digital slide show or album), and store still and/or video images.

[0177] In conjunction with RF circuitry 1708, touch screen 1712, display system controller 1756, contact module 1730, graphics module 1732, and text input module 1734, browser module 1747 includes executable instructions to browse the Internet in accordance with user instructions, including searching, linking to, receiving, and displaying web pages or portions thereof, as well as attachments and other files linked to web pages.

[0178] In conjunction with RF circuitry 1708, touch screen 1712, display system controller 1756, contact module 1730, graphics module 1732, text input module 1734, e-mail client module 1740, and browser module 1747, calendar module 1748 includes executable instructions to create, display, modify, and store calendars and data associated with calendars (e.g., calendar entries, to do lists, etc.) in accordance with user instructions.

[0179] In conjunction with RF circuitry 1708, touch screen 1712, display system controller 1756, contact module 1730, graphics module 1732, text input module 1734, and browser module 1747, widget modules 1749 are mini-applications that may be downloaded and used by a user (e.g., weather widget 549-1, stocks widget 549-2, calculator widget 1749-3, alarm clock widget 1749-4, and dictionary widget 1749-5) or created by the user (e.g., user-created widget 1749-6). In some embodiments, a widget includes an HTML (Hypertext Markup Language) file, a CSS (Cascading Style Sheets) file, and a JavaScript file. In some embodiments, a widget includes an XML (Extensible Markup Language) file and a JavaScript file (e.g., Yahoo! Widgets).

[0180] In conjunction with RF circuitry 1708, touch screen 1712, display system controller 1756, contact module 1730, graphics module 1732, text input module 1734, and browser module 1747, the widget creator module 1750 may be used by a user to create widgets (e.g., turning a user-specified portion of a web page into a widget).

[0181] In conjunction with touch screen 1712, display system controller 1756, contact module 1730, graphics module 1732, and text input module 1734, search module 1751 includes executable instructions to search for text, music, sound, image, video, and/or other files in memory 1702 that match one or more search criteria (e.g., one or more user-specified search terms) in accordance with user instructions.

[0182] In conjunction with touch screen 1712, display system controller 1756, contact module 1730, graphics module 1732, audio circuitry 1710, speaker 1711, RF circuitry 1708, and browser module 1747, video and music player module 1752 includes executable instructions that allow the user to download and play back recorded music and other sound files stored in one or more file formats, such as MP3 or AAC files, and executable instructions to display, present or otherwise play back videos (e.g., on touch screen 1712 or on an external, connected display via external port 1724). In some embodiments, device 1700 may include the functionality of an MP3 player.

[0183] In conjunction with touch screen 1712, display controller 1756, contact module 1730, graphics module 1732, and text input module 1734, notes module 1753 includes executable instructions to create and manage notes, to do lists, and the like in accordance with user instructions.

[0184] In conjunction with RF circuitry 1708, touch screen 1712, display system controller 1756, contact module 1730, graphics module 1732, text input module 1734, GPS module 1735, and browser module 1747, map module 1754 may be used to receive, display, modify, and store maps and data associated with maps (e.g., driving directions; data on stores and other points of interest at or near a particular location; and other location-based data) in accordance with user instructions.

[0185] In conjunction with touch screen 1712, display system controller 1756, contact module 1730, graphics module 1732, audio circuitry 1710, speaker 1711, RF circuitry 1708, text input module 1734, e-mail client module 1740, and browser module 1747, online video module 1755 includes instructions that allow the user to access, browse, receive (e.g., by streaming and/or download), play back (e.g., on the touch screen or on an external, connected display via external port 1724), send an e-mail with a link to a particular online video, and otherwise manage online videos in one or more file formats, such as H.264. In some embodiments, instant messaging module 1741, rather than e-mail client module 1740, is used to send a link to a particular online video.

[0186] Each of the above identified modules and applications correspond to a set of executable instructions for performing one or more functions described above and the methods described in this application (e.g., the computer-implemented methods and other information processing methods described herein). These modules (i.e., sets of instructions) need not be implemented as separate software programs, procedures or modules, and thus various subsets of these modules may be combined or otherwise re-arranged in various embodiments. In some embodiments, memory 1702 may store a subset of the modules and data structures identified above. Furthermore, memory 1702 may store additional modules and data structures not described above.

[0187] In some embodiments, device 1700 is a device where operation of a predefined set of functions on the device is performed exclusively through a touch screen and/or a touchpad. By using a touch screen and/or a touchpad as the primary input control device for operation of device 1700, the number of physical input control devices (such as push buttons, dials, and the like) on device 1700 may be reduced.

[0188] The predefined set of functions that may be performed exclusively through a touch screen and/or a touchpad include navigation between user interfaces. In some embodiments, the touchpad, when touched by the user, navigates device 1700 to a main, home, or root menu from any user interface that may be displayed on device 1700. In such embodiments, the touchpad may be referred to as a “menu button.” In some other embodiments, the menu button may be a physical push button or other physical input control device instead of a touchpad.

[0189] FIG. 18 depicts illustrates an example portable multifunction device 1700 that may include one or more cameras (e.g., the cameras described above with reference to FIGS. 1-16), in accordance with some embodiments. The device 1700 may have a touch screen 1702. The touch screen 1718 may display one or more graphics within user interface (UI) 1800. In this embodiment, as well as others described below, a user may select one or more of the graphics by making a gesture on the graphics, for example, with one or

more fingers 1802 (not drawn to scale in the figure) or one or more styluses 1803 (not drawn to scale in the figure).

[0190] Device 1700 may also include one or more physical buttons, such as “home” or menu button 1804. As described previously, menu button 1804 may be used to navigate to any application 1736 in a set of applications that may be executed on device 1700. Alternatively, in some embodiments, the menu button 1804 is implemented as a soft key in a GUI displayed on touch screen 1712.

[0191] In one embodiment, device 1700 includes touch screen 1712, menu button 1804, push button 1806 for powering the device on/off and locking the device, volume adjustment button(s) 1808, Subscriber Identity Module (SIM) card slot 1810, head set jack 1812, and docking/charging external port 1824. Push button 1806 may be used to turn the power on/off on the device by depressing the button and holding the button in the depressed state for a predefined time interval; to lock the device by depressing the button and releasing the button before the predefined time interval has elapsed; and/or to unlock the device or initiate an unlock process. In an alternative embodiment, device 1700 also may accept verbal input for activation or deactivation of some functions through microphone 1713.

[0192] It should be noted that, although many of the examples herein are given with reference to optical sensor (s)/camera(s) 1764 (on the front of a device), one or more rear-facing cameras or optical sensors that are pointed opposite from the display may be used instead of, or in addition to, an optical sensor(s)/camera(s) 1764 on the front of a device.

#### Example Computer System

[0193] FIG. 19 illustrates an example computer system 1900 that may include one or more cameras (e.g., the cameras described above with reference to FIGS. 1-16), according to some embodiments. The computer system 1900 may be configured to execute any or all of the embodiments described above. In different embodiments, computer system 1900 may be any of various types of devices, including, but not limited to, a personal computer system, desktop computer, laptop, notebook, tablet, slate, pad, or netbook computer, mainframe computer system, handheld computer, workstation, network computer, a camera, a set top box, a mobile device, a consumer device, video game console, handheld video game device, application server, storage device, a television, a video recording device, a peripheral device such as a switch, modem, router, or in general any type of computing or electronic device.

[0194] Various embodiments of a camera motion control system as described herein, including embodiments of magnetic position sensing, as described herein may be executed in one or more computer systems 1900, which may interact with various other devices. Note that any component, action, or functionality described above with respect to FIGS. 1-18 may be implemented on one or more computers configured as computer system 1900 of FIG. 19, according to various embodiments. In the illustrated embodiment, computer system 1900 includes one or more processors 1910 coupled to a system memory 1920 via an input/output (I/O) interface 1930. Computer system 1900 further includes a network interface 1940 coupled to I/O interface 1930, and one or more input/output devices 1950, such as cursor control device 1960, keyboard 1970, and display(s) 1980. In some cases, it is contemplated that embodiments may be imple-

mented using a single instance of computer system **1900**, while in other embodiments multiple such systems, or multiple nodes making up computer system **1900**, may be configured to host different portions or instances of embodiments. For example, in one embodiment some elements may be implemented via one or more nodes of computer system **1900** that are distinct from those nodes implementing other elements.

[0195] In various embodiments, computer system **1900** may be a uniprocessor system including one processor **1910**, or a multiprocessor system including several processors **1910** (e.g., two, four, eight, or another suitable number). Processors **1910** may be any suitable processor capable of executing instructions. For example, in various embodiments processors **1910** may be general-purpose or embedded processors implementing any of a variety of instruction set architectures (ISAs), such as the x86, PowerPC, SPARC, or MIPS ISAs, or any other suitable ISA. In multiprocessor systems, each of processors **1910** may commonly, but not necessarily, implement the same ISA.

[0196] System memory **1920** may be configured to store camera control program instructions **1922** and/or camera control data accessible by processor **1910**. In various embodiments, system memory **1920** may be implemented using any suitable memory technology, such as static random access memory (SRAM), synchronous dynamic RAM (SDRAM), nonvolatile/Flash-type memory, or any other type of memory. In the illustrated embodiment, program instructions **1922** may be configured to implement a lens control application **1924** incorporating any of the functionality described above. Additionally, existing camera control data **1932** of memory **1920** may include any of the information or data structures described above. In some embodiments, program instructions and/or data may be received, sent or stored upon different types of computer-accessible media or on similar media separate from system memory **1920** or computer system **1900**. While computer system **1900** is described as implementing the functionality of functional blocks of previous Figures, any of the functionality described herein may be implemented via such a computer system.

[0197] In one embodiment, I/O interface **1930** may be configured to coordinate I/O traffic between processor **1910**, system memory **1920**, and any peripheral devices in the device, including network interface **1940** or other peripheral interfaces, such as input/output devices **1950**. In some embodiments, I/O interface **1930** may perform any necessary protocol, timing or other data transformations to convert data signals from one component (e.g., system memory **1920**) into a format suitable for use by another component (e.g., processor **1910**). In some embodiments, I/O interface **1930** may include support for devices attached through various types of peripheral buses, such as a variant of the Peripheral Component Interconnect (PCI) bus standard or the Universal Serial Bus (USB) standard, for example. In some embodiments, the function of I/O interface **1930** may be split into two or more separate components, such as a north bridge and a south bridge, for example. Also, in some embodiments some or all of the functionality of I/O interface **1930**, such as an interface to system memory **1920**, may be incorporated directly into processor **1910**.

[0198] Network interface **1940** may be configured to allow data to be exchanged between computer system **1900** and other devices attached to a network **1985** (e.g., carrier or

agent devices) or between nodes of computer system **1900**. Network **1985** may in various embodiments include one or more networks including but not limited to Local Area Networks (LANs) (e.g., an Ethernet or corporate network), Wide Area Networks (WANs) (e.g., the Internet), wireless data networks, some other electronic data network, or some combination thereof. In various embodiments, network interface **1940** may support communication via wired or wireless general data networks, such as any suitable type of Ethernet network, for example; via telecommunications/telephony networks such as analog voice networks or digital fiber communications networks; via storage area networks such as Fibre Channel SANs, or via any other suitable type of network and/or protocol.

[0199] Input/output devices **1950** may, in some embodiments, include one or more display terminals, keyboards, keypads, touchpads, scanning devices, voice or optical recognition devices, or any other devices suitable for entering or accessing data by one or more computer systems **1900**. Multiple input/output devices **1950** may be present in computer system **1900** or may be distributed on various nodes of computer system **1900**. In some embodiments, similar input/output devices may be separate from computer system **1900** and may interact with one or more nodes of computer system **1900** through a wired or wireless connection, such as over network interface **1940**.

[0200] As shown in FIG. 19, memory **1920** may include program instructions **1922**, which may be processor-executable to implement any element or action described above. In one embodiment, the program instructions may implement the methods described above. In other embodiments, different elements and data may be included. Note that data may include any data or information described above.

[0201] Those skilled in the art will appreciate that computer system **1900** is merely illustrative and is not intended to limit the scope of embodiments. In particular, the computer system and devices may include any combination of hardware or software that can perform the indicated functions, including computers, network devices, Internet appliances, PDAs, wireless phones, pagers, etc. Computer system **1900** may also be connected to other devices that are not illustrated, or instead may operate as a stand-alone system. In addition, the functionality provided by the illustrated components may in some embodiments be combined in fewer components or distributed in additional components. Similarly, in some embodiments, the functionality of some of the illustrated components may not be provided and/or other additional functionality may be available.

[0202] Those skilled in the art will also appreciate that, while various items are illustrated as being stored in memory or on storage while being used, these items or portions of them may be transferred between memory and other storage devices for purposes of memory management and data integrity. Alternatively, in other embodiments some or all of the software components may execute in memory on another device and communicate with the illustrated computer system via inter-computer communication. Some or all of the system components or data structures may also be stored (e.g., as instructions or structured data) on a computer-accessible medium or a portable article to be read by an appropriate drive, various examples of which are described above. In some embodiments, instructions stored on a computer-accessible medium separate from computer system **1900** may be transmitted to computer system **1900** via

transmission media or signals such as electrical, electromagnetic, or digital signals, conveyed via a communication medium such as a network and/or a wireless link. Various embodiments may further include receiving, sending or storing instructions and/or data implemented in accordance with the foregoing description upon a computer-accessible medium. Generally speaking, a computer-accessible medium may include a non-transitory, computer-readable storage medium or memory medium such as magnetic or optical media, e.g., disk or DVD/CD-ROM, volatile or non-volatile media such as RAM (e.g. SDRAM, DDR, RDRAM, SRAM, etc.), ROM, etc. In some embodiments, a computer-accessible medium may include transmission media or signals such as electrical, electromagnetic, or digital signals, conveyed via a communication medium such as network and/or a wireless link.

**[0203]** The methods described herein may be implemented in software, hardware, or a combination thereof, in different embodiments. In addition, the order of the blocks of the methods may be changed, and various elements may be added, reordered, combined, omitted, modified, etc. Various modifications and changes may be made as would be obvious to a person skilled in the art having the benefit of this disclosure. The various embodiments described herein are meant to be illustrative and not limiting. Many variations, modifications, additions, and improvements are possible. Accordingly, plural instances may be provided for components described herein as a single instance. Boundaries between various components, operations and data stores are somewhat arbitrary, and particular operations are illustrated in the context of specific illustrative configurations.

**[0204]** Additional descriptions of embodiments (example clauses):

**[0205]** Clause 1: A camera, comprising: a folded optics arrangement to fold a path of light, the folded optics arrangement comprising: a first prism; a second prism; and a lens group disposed between the first prism and the second prism, wherein the lens group includes one or more lens elements; an image sensor to capture light that has passed through the first prism, the lens group, and the second prism; an actuator module to move the lens group along multiple axes; and a carrier structure that at least partially encircles the folded optics arrangement, wherein the carrier structure is coupled with the lens group such that the carrier structure and the lens group are moveable together relative to the image sensor.

**[0206]** Clause 2: The camera of Clause 1, wherein the actuator module comprises: a first optical image stabilization (OIS) voice coil motor (VCM) actuator to move the lens group to provide OIS movement of an image, captured via the image sensor, in at least a first direction; a second OIS VCM actuator to move the lens group to provide OIS movement of the image in at least a second direction that is orthogonal to the first direction; and an autofocus (AF) VCM actuator to move the lens group to provide AF movement of the image in at least a third direction that is orthogonal to the first direction and the second direction.

**[0207]** Clause 3: The camera of any of Clauses 1-2, wherein: the actuator module comprises: one or more magnets; and one or more coils; the carrier structure comprises an inner frame to which at least one coil of the one or more coils is attached; and the camera further comprises: an outer frame to which at least one magnet of the one or more

magnets is attached, wherein the outer frame at least partially encircles the inner frame.

**[0208]** Clause 4: The camera of any of Clauses 1-3, further comprising: a suspension arrangement to suspend the lens group and allow movement of the lens group along the multiple axes, wherein the suspension arrangement comprises: a leaf spring attached to the carrier structure; and suspension wires, wherein a suspension wire of the suspension wires comprises: a first end portion attached to the leaf spring; and a second end portion attached to a fixed structure that is stationary relative to movement of the lens group.

**[0209]** Clause 5: The camera of any of Clauses 1-4, wherein: the first prism and the second prism are positioned along an optical axis defined by the lens group; and the image sensor defines a plane that is parallel to the optical axis.

**[0210]** Clause 6: A device, comprising: one or more processors; memory storing program instructions executable by the one or more processors to control operation of a camera; and the camera, comprising: a folded optics arrangement to fold a path of light, the folded optics arrangement comprising: a first prism; a second prism; and a lens group disposed between the first prism and the second prism, wherein the lens group includes one or more lens elements; an image sensor to capture light that has passed through the first prism, the lens group, and the second prism; an actuator module to move the lens group along multiple axes; and a carrier structure that at least partially encircles the folded optics arrangement, wherein the carrier structure is coupled with the lens group such that the carrier structure and the lens group are moveable together relative to the image sensor.

**[0211]** Clause 7: The device of Clause 6, wherein the one or more processors are further to: cause the actuator module to move the carrier structure, in at least a first direction parallel to an optical axis defined by the lens group, to provide autofocus (AF) movement of an image captured via the image sensor; cause the actuator module to move the carrier structure, in at least a second direction that is orthogonal to the first direction, to provide optical image stabilization movement of the image; and cause the actuator module to move the carrier structure, in at least a third direction that is orthogonal to the first direction and the second direction.

**[0212]** Clause 8: The device of any of Clauses 6-7, wherein: the actuator module comprises: one or more magnets; and one or more coils; the carrier structure comprises an inner frame to which at least one coil of the one or more coils is attached; and the camera further comprises: an outer frame to which at least one magnet of the one or more magnets is attached, wherein the outer frame at least partially encircles the inner frame.

**[0213]** Clause 9: The device of any of Clauses 6-8, wherein: the first prism comprises: an object side through which light enters the first prism; and a first reflecting surface side comprising a first reflective surface to redirect the light towards the lens group; and the second prism comprises: a second reflecting surface side comprising a second reflective surface to redirect the light towards the image sensor; and an image side through which the light exits the first prism, the image side proximate the image sensor.

**[0214]** Clause 10: The device of any of Clauses 6-9, wherein: the first reflecting surface side is angled relative to

the object side of the first prism; and the actuator module comprises a voice coil motor (VCM) actuator having at least one magnet and at least one coil disposed within a space under the first reflecting surface side.

**[0215]** Clause 11: The device of any of Clauses 6-10, wherein the VCM actuator comprises an autofocus (AF) actuator to move the carrier structure, in at least a first direction parallel to an optical axis defined by the lens group, to provide AF movement of an image captured via the image sensor.

**[0216]** Clause 12: The device of any of Clauses 6-11, wherein the camera further comprises: a suspension arrangement to suspend the lens group and allow movement of the lens group along the multiple axes, wherein the suspension arrangement comprises: a leaf spring attached to the carrier structure; and suspension wires, wherein a suspension wire of the suspension wires comprises: a first end portion attached to the leaf spring; and a second end portion attached to a fixed structure that is stationary relative to movement of the lens group.

**[0217]** Clause 13: The device of any of Clauses 6-12, wherein: the leaf spring is an upper leaf spring attached to a top surface of the carrier structure, the upper leaf spring extending along a first plane that is parallel to the image sensor; the suspension wire is a first suspension wire that extends from the upper leaf spring in a first direction that is orthogonal to an optical axis defined by the lens group; the suspension arrangement further comprises a lower leaf spring attached to a bottom surface of the carrier structure, the lower leaf spring extending along a second plane that is parallel to the image sensor; and the suspension wires further comprise a second suspension wire that extends from the lower leaf spring in a second direction opposite the first direction.

**[0218]** Clause 14: The device of any of Clauses 6-13, wherein: the carrier structure comprises an inner frame; and the camera further comprises: an outer frame that at least partially encircles the inner frame; and a suspension arrangement to suspend the lens group and allow movement of the lens group along the multiple axes, wherein the suspension arrangement comprises: flexure arms to mechanically connect the inner frame to the outer frame, the flexure arms extending along a plane that is parallel to the image sensor.

**[0219]** Clause 15: The device of any of Clauses 6-14, wherein: the camera further comprises a lens holder to hold the lens group; and the carrier structure is fixedly attached to the lens holder.

**[0220]** Clause 16: A folded optics system, comprising: a lens group including one or more lens elements; a first prism to redirect light to the lens group; a second prism to receive the light from the lens group and redirect the light to an image sensor; an actuator module to move the lens group along multiple axes; and a carrier structure to couple with the lens group such that the carrier structure and the lens group are moveable together relative to the image sensor, wherein the carrier structure is to at least partially encircle the lens group, the first prism, and the second prism.

**[0221]** Clause 17: The folded optics system of Clause 16, wherein the actuator module comprises: a first optical image stabilization (OIS) voice coil motor (VCM) actuator to move the lens group to provide OIS movement of an image, captured via the image sensor, in at least a first direction; a second OIS VCM actuator to move the lens group to provide OIS movement of the image in at least a second direction

that is orthogonal to the first direction; and an autofocus (AF) VCM actuator to move the lens group to provide AF movement of the image in at least a third direction that is orthogonal to the first direction and the second direction.

**[0222]** Clause 18: The folded optics system of any of Clauses 16-17, wherein: the actuator module comprises: one or more magnets; and one or more coils; a first portion of the actuator module is attached to the carrier structure; and a second portion of the actuator module is attached to a base structure that is fixed relative to movement of the carrier structure.

**[0223]** Clause 19: The folded optics system of any of Clauses 16-18, wherein: the first prism comprises: an object side through which light enters the first prism; and a first reflecting surface side comprising a first reflective surface to redirect the light to the lens group; the second prism comprises: a second reflecting surface side comprising a second reflective surface to redirect the light to the image sensor; an image side through which the light exits the first prism, the image side proximate the image sensor; the first reflecting surface side is angled relative to the object side of the first prism; and the actuator module comprises a voice coil motor (VCM) actuator having at least one magnet and at least one coil disposed within a space under the first reflecting surface side.

**[0224]** Clause 20: The folded optics system of any of Clauses 16-19, wherein: the lens group is disposed between the first prism and the second prism; and the first prism and the prism are positioned along an optical axis defined by the lens group.

**[0225]** Other allocations of functionality are envisioned and may fall within the scope of claims that follow. Finally, structures and functionality presented as discrete components in the example configurations may be implemented as a combined structure or component. These and other variations, modifications, additions, and improvements may fall within the scope of embodiments as defined in the claims that follow.

**1.-20.** (canceled)

**21.** A camera, comprising:

a folded optics arrangement to fold a path of light, the folded optics arrangement comprising:

a first prism;

a second prism; and

a lens group disposed between the first prism and the second prism, wherein the lens group includes one or more lens elements that define an optical axis;

an image sensor to capture light that has passed through the first prism, the lens group, and the second prism;

a carrier structure that at least partially encircles the folded optics arrangement, wherein the carrier structure is coupled with the lens group such that the carrier structure and the lens group are moveable together relative to the image sensor;

an actuator to move the lens group along multiple axes; and

a suspension arrangement to suspend the carrier structure and allow movement of the lens group along the multiple axes, the suspension arrangement comprising one or more leaf springs attached to the carrier structure and extending along a plane that is parallel to the image sensor and to the optical axis.

**22.** The camera of claim 21, wherein the carrier structure comprises a top surface and a bottom surface that is distinct



from the top surface, and wherein the one or more leaf springs comprises an upper leaf spring extending along a first plane that is parallel to the image sensor and to the optical axis, wherein the upper leaf spring is attached to the top surface of the carrier structure.

**23.** The camera of claim **22**, wherein the one or more leaf springs further comprises a lower leaf spring that extends along a second plane that is parallel to the first plane and is closer to the image sensor than the first plane, wherein the lower leaf spring is attached to the bottom surface of the carrier structure.

**24.** The camera of claim **21**, wherein the suspension arrangement includes a damping arrangement configured to damp movement of one or more parts of the suspension arrangement.

**25.** The camera of claim **24**, wherein the damping arrangement comprises a viscoelastic material.

**26.** The camera of claim **25**, wherein the wherein the viscoelastic material is disposed within one or more protrusions of the carrier structure, and wherein the one or parts of the suspension arrangement whose movement is to be damped are configured to be in contact with the viscoelastic material.

**27.** The camera of claim **21**, wherein the suspension arrangement further comprises one or more flexure arms coupled to the carrier structure and to a fixed base structure that surrounds the carrier structure.

**28.** The camera of claim **21**, wherein the carrier structure comprises:

- an inner frame to which at least one coil of the actuator is attached; and
- an outer frame to which at least one magnet of the actuator is attached, wherein the outer frame at least partially encircles the inner frame.

**29.** The camera of claim **28**, wherein the suspension arrangement further comprises flexure arms to mechanically connect the inner frame to the outer frame.

**30.** A device, comprising:  
one or more processors;

memory storing program instructions executable by the one or more processors to control operation of a camera; and

the camera, comprising:

a folded optics arrangement to fold a path of light, the folded optics arrangement comprising:

- a first prism;
- a second prism; and

a lens group disposed between the first prism and the second prism, wherein the lens group includes one or more lens elements that define an optical axis;

an image sensor to capture light that has passed through the first prism, the lens group, and the second prism;

a carrier structure that at least partially encircles the folded optics arrangement, wherein the carrier structure is coupled with the lens group such that the carrier structure and the lens group are moveable together relative to the image sensor;

an actuator to move the lens group along multiple axes; and

a suspension arrangement to suspend the carrier structure and allow movement of the lens group along the multiple axes, the suspension arrangement comprising one or more leaf springs attached to the carrier

structure and extending along a plane that is parallel to the image sensor and to the optical axis.

**31.** The device of claim **30**, wherein the carrier structure comprises a top surface and a bottom surface that is distinct from the top surface, and wherein the one or more the leaf springs includes an upper leaf spring extending along a first plane that is parallel to the image sensor and to the optical axis, wherein the upper leaf spring is attached to the top surface of the carrier structure.

**32.** The device of claim **31**, wherein the one or more the leaf springs includes a lower leaf spring that extends along a second plane that is parallel to the first plane and is closer to the image sensor than the first plane, wherein the lower leaf spring is attached to the bottom surface of the carrier structure.

**33.** The device of claim **30**, wherein the suspension arrangement includes a damping arrangement configured to damp movement of one or more parts of the suspension arrangement.

**34.** The device of claim **33**, wherein the damping arrangement comprises a viscoelastic material.

**35.** The device of claim **34**, wherein the wherein the viscoelastic material is disposed within one or more protrusions of the carrier structure, and wherein the one or parts of the suspension arrangement are configured to be in contact with the viscoelastic material within the one or more protrusions.

**36.** The device of claim **30**, wherein the actuator module is configured to:

move the carrier structure, in at least a first direction parallel to an optical axis defined by the lens group, to provide autofocus (AF) movement of an image captured via the image sensor;

move the carrier structure, in at least a second direction that is orthogonal to the first direction, to provide optical image stabilization movement of the image; or

move the carrier structure, in at least a third direction that is orthogonal to the first direction and the second direction.

**37.** A folded optics system, comprising:

a folded optics arrangement comprising:

- a first prism to redirect light to a lens group;
- a second prism to receive the light from the lens group and redirect the light to an image sensor; and
- the lens group disposed between the first prism and the second prism, wherein the lens group includes one or more lens elements that define an optical axis;

a carrier structure that at least partially encircles the folded optics arrangement, wherein the carrier structure is coupled with the lens group such that the carrier structure and the lens group are moveable together relative to the image sensor; and

a suspension arrangement to suspend the carrier structure and allow movement of the lens group along multiple axes, the suspension arrangement comprising one or more leaf springs attached to the carrier structure and extending along a plane that is parallel to the image sensor and to the optical axis.

**38.** The folded optics system of claim **37**, wherein the suspension arrangement further comprises one or more flexure arms coupled to the carrier structure and to a fixed base structure that surrounds the carrier structure.

**39.** The folded optics system of claim **37**, wherein the carrier structure comprises:

an inner frame to which at least one coil of an actuator is attached, the actuator configured to move the lens group along multiple axes; and

an outer frame to which at least one magnet of the actuator is attached, wherein the outer frame at least partially encircles the inner frame.

**40.** The folded optics system of claim **39**, wherein the suspension arrangement further comprises:

one or more flexure arms to mechanically connect the inner frame to the outer frame.

\* \* \* \* \*