



US 20200411817A1

(19) **United States**

(12) **Patent Application Publication**
YOU et al.

(10) **Pub. No.: US 2020/0411817 A1**

(43) **Pub. Date: Dec. 31, 2020**

(54) **BATTERY PACK AND VEHICLE**

Publication Classification

(71) Applicant: **Contemporary Amperex Technology Co., Limited**, Ningde City (CN)

(51) **Int. Cl.**
H01M 2/10 (2006.01)
H01M 10/04 (2006.01)
H01M 2/30 (2006.01)

(72) Inventors: **Kaijie YOU**, Ningde City (CN); **Yongguang Wang**, Ningde City (CN); **Yu Tang**, Ningde City (CN); **Weilong Lin**, Ningde City (CN); **Jun Ma**, Ningde City (CN)

(52) **U.S. Cl.**
CPC *H01M 2/1077* (2013.01); *H01M 10/0431* (2013.01); *H01M 2220/20* (2013.01); *H01M 2/305* (2013.01); *H01M 10/0413* (2013.01)

(21) Appl. No.: **16/856,883**

(22) Filed: **Apr. 23, 2020**

(30) **Foreign Application Priority Data**

Jun. 27, 2019 (CN) 201910565257.4

(57) **ABSTRACT**

A battery pack and a vehicle, wherein the battery pack includes a box assembly, a battery unit, a constraint component and an outer cover, the box assembly includes a box body and a fixed beam, the fixed beam is fixed in the box body; the battery unit is arranged in the box body; the constraint component covers the battery unit and is fixed with the fixed beam; and the outer cover is arranged on one side of the constraint component away from the box body to seal an open end of the box body.

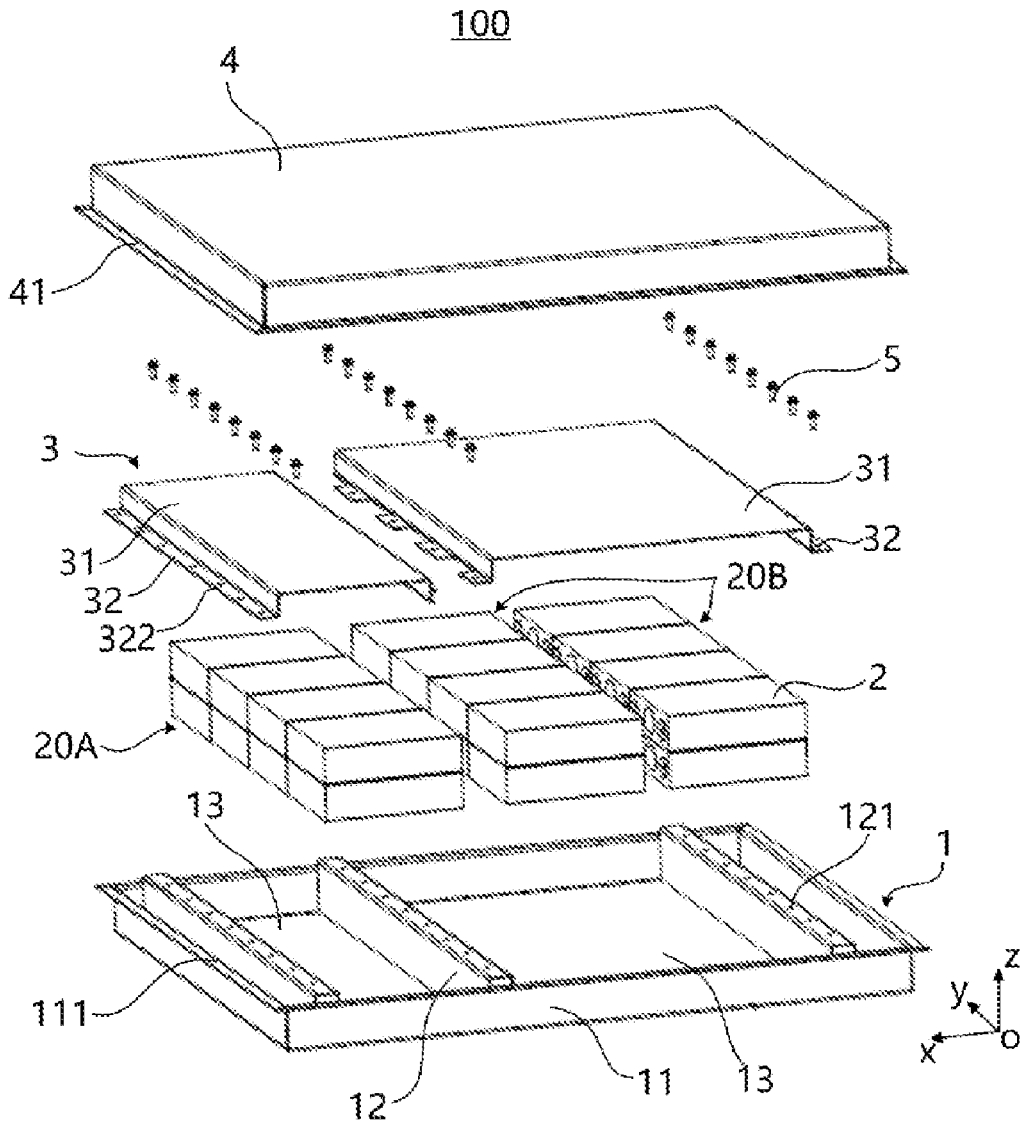

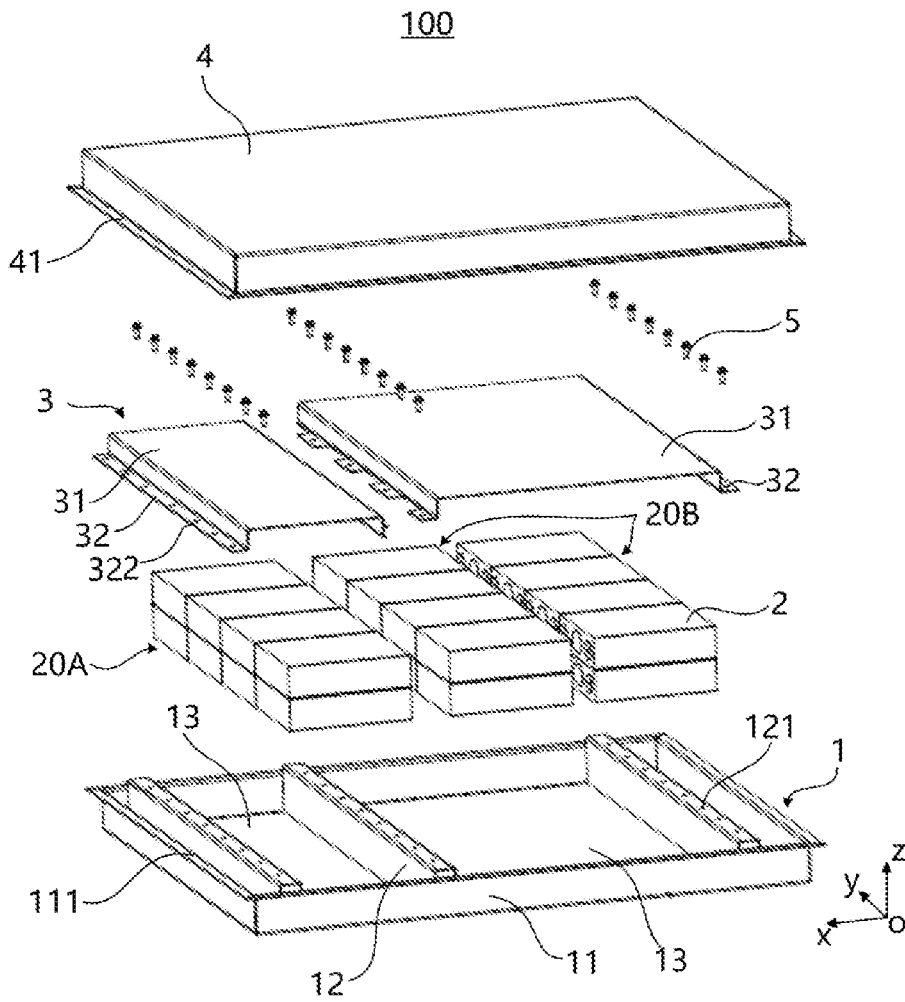

Fig. 1

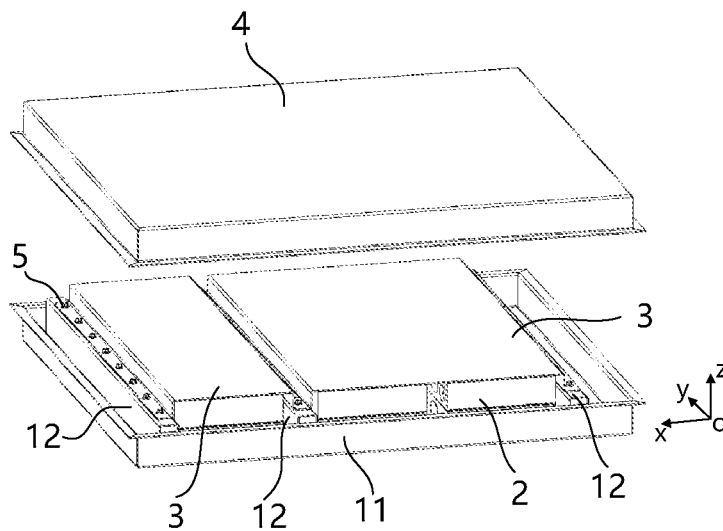

Fig. 2

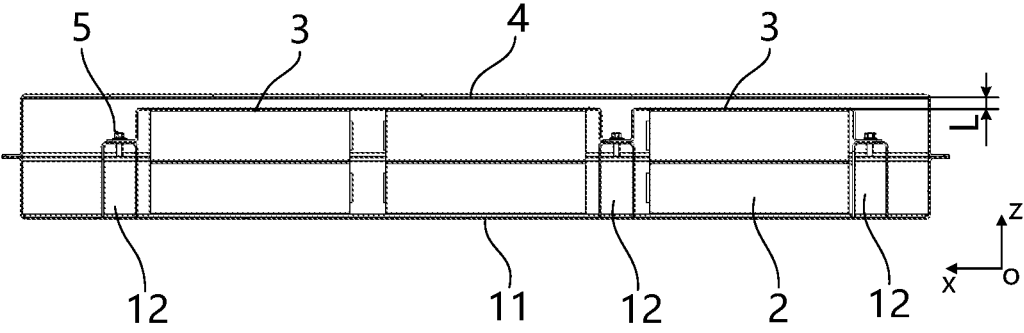

Fig. 3

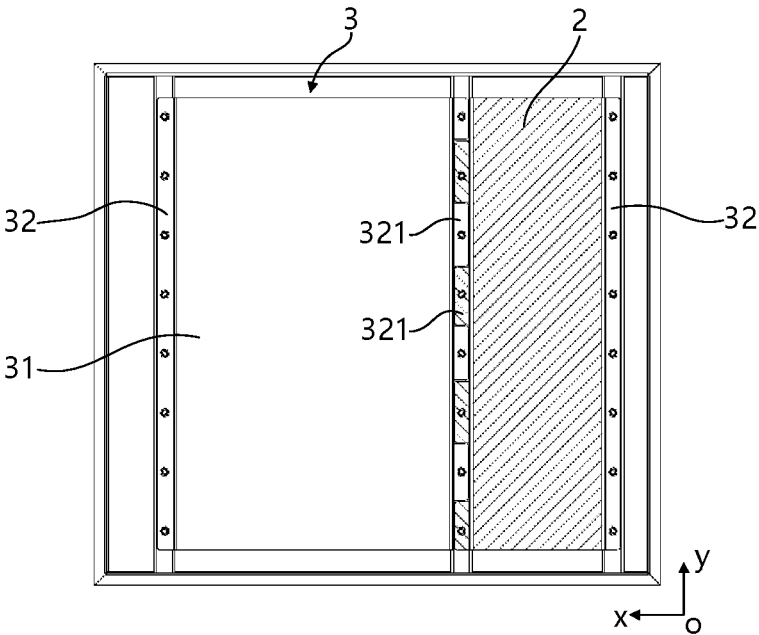

Fig. 4

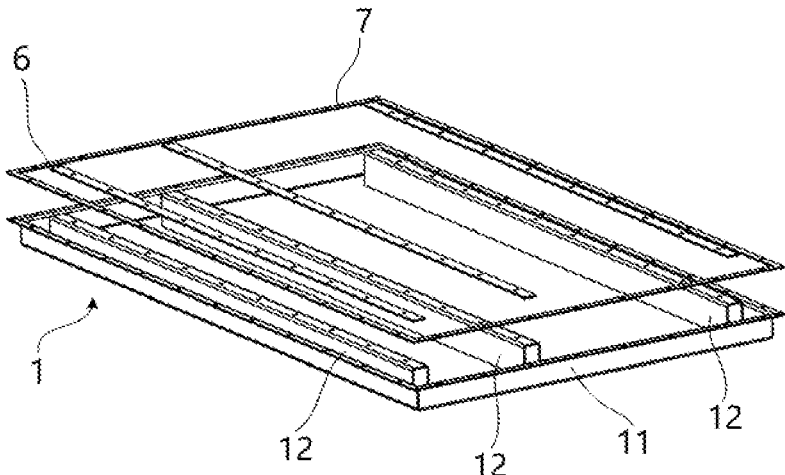

Fig. 5

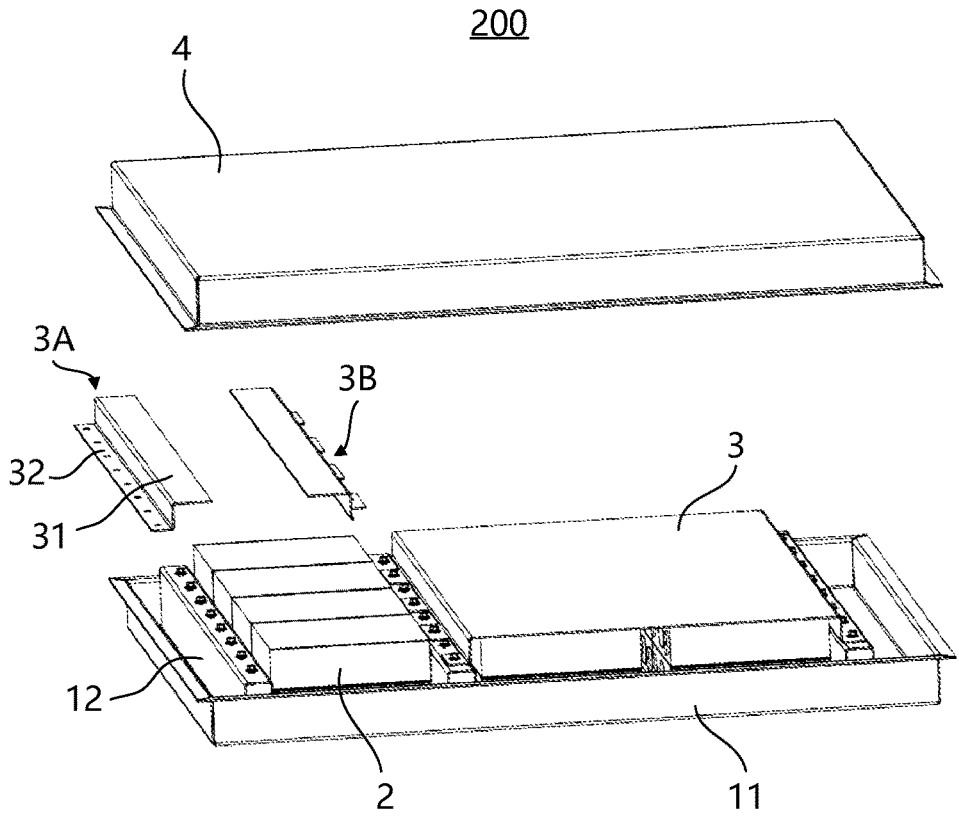

Fig. 6

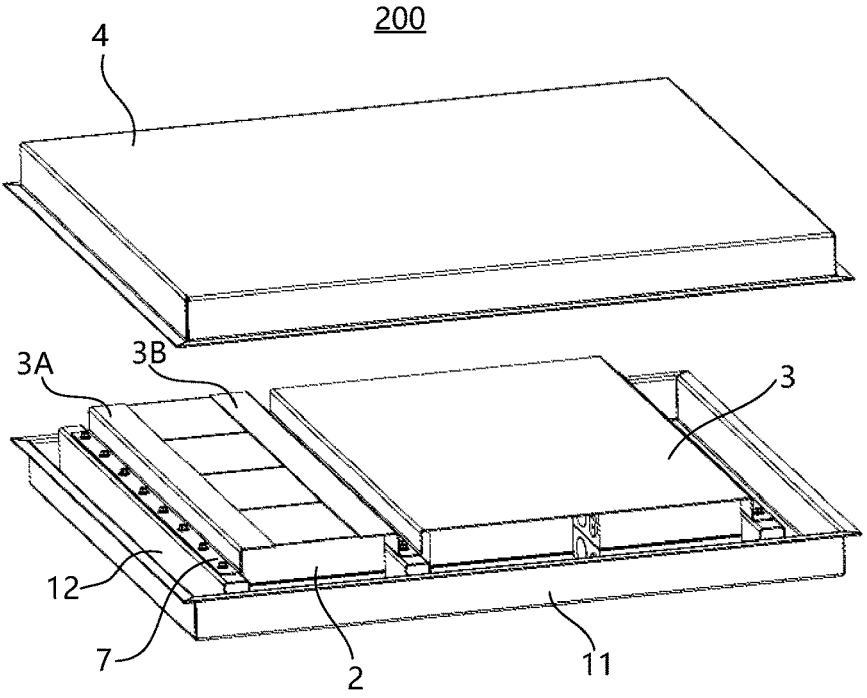

Fig. 7

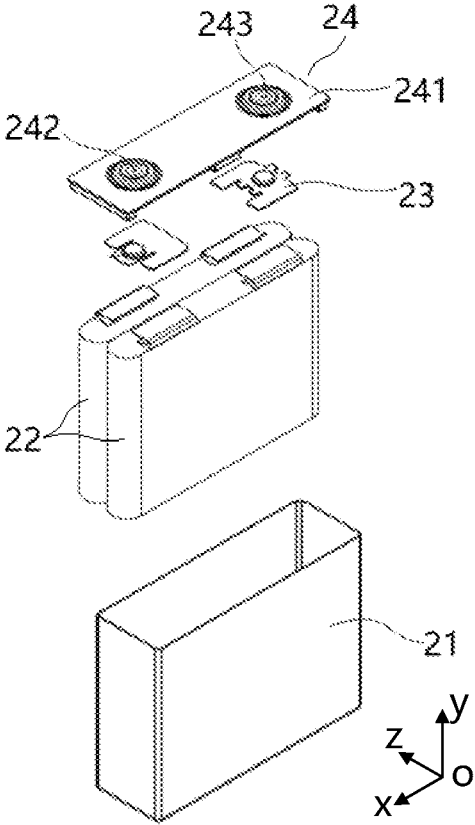

Fig. 8

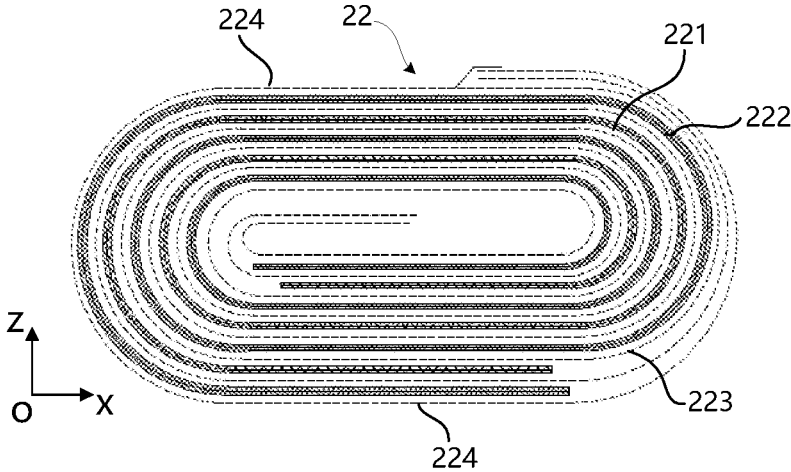

Fig. 9

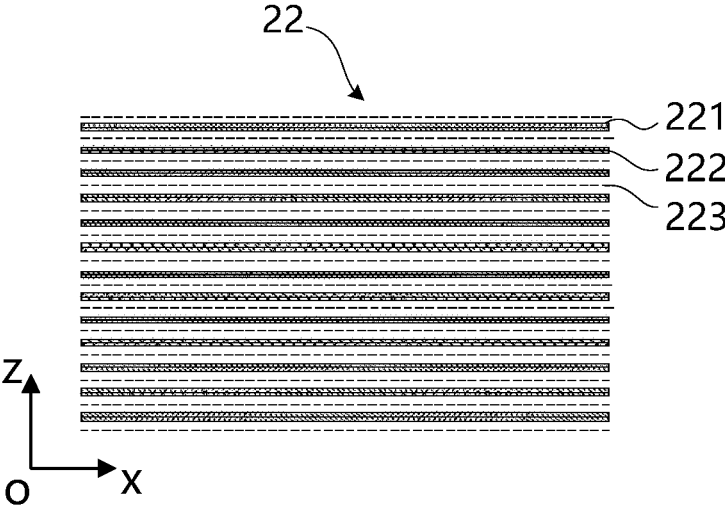

Fig. 10

BATTERY PACK AND VEHICLE**CROSS-REFERENCE TO RELATED APPLICATION**

[0001] The present application claims priority of Chinese application No. 201910565257.4, filed on Jun. 27, 2019. The disclosed content of the Chinese application is hereby entirely incorporated into the present disclosure.

FIELD OF THE DISCLOSURE

[0002] The present disclosure relates to the technical field of batteries, and, to a battery pack and a vehicle.

BACKGROUND OF THE DISCLOSURE

[0003] In recent years, rechargeable batteries have been widely used for providing power for high-power devices, such as electric vehicles and the like. The rechargeable batteries achieve greater capacity or power by connecting a plurality of battery units in series, in parallel or in series parallel.

SUMMARY OF THE DISCLOSURE

[0004] According to one aspect of the present disclosure, a battery pack is provided, including:

[0005] a box assembly, including a box body and a fixed beam, wherein the fixed beam is fixed in the box body;

[0006] a battery unit, arranged in the box body;

[0007] a constraint component covering the battery unit and fixed with the fixed beam; and

[0008] an outer cover arranged on one side of the constraint component away from the box body to seal an open end of the box body.

[0009] In some embodiments, the box body is divided into a plurality of accommodation cavities by the fixed beam, the battery pack includes a plurality of battery units, and the plurality of battery units are divided into several groups of battery units in a plane perpendicular to the height direction of the battery pack, and several groups of the battery units each has at least two battery units and are respectively arranged in different accommodation cavities.

[0010] In some embodiments, the box assembly includes a plurality of fixed beams arranged on both sides of each group of battery units along a grouping direction in which the battery units are divided into several groups.

[0011] In some embodiments, a plurality of battery units are divided into several groups along a length direction of the battery pack, the fixed beam extends along a width direction of the battery pack; and/or

[0012] the plurality of battery units are divided into several groups along a width direction of the battery pack, and the fixed beam extends along a length direction of the battery pack.

[0013] In some embodiments, the battery pack includes a plurality of constraint components, and the constraint components respectively cover different groups of the battery units.

[0014] In some embodiments, the constraint component includes:

[0015] a limiting portion covering the same group of battery units; and

[0016] two mounting portions, respectively connected to the both sides of the limiting portion along a grouping direction of the battery units, wherein the two mounting

portions are respectively fixed with the fixed beams on the both sides of the same groups of battery units.

[0017] In some embodiments, the whole limiting portion protrudes relative to the mounting portion toward a direction away from the battery units.

[0018] In some embodiments, there is only one fixed beam arranged between two adjacent groups of battery units, each of the two adjacent mounting portions fixed with the fixed beam includes a plurality of mounting blocks, the plurality of mounting blocks are arranged along an extension direction of the fixed beam at intervals, and the plurality of mounting blocks of the two adjacent mounting portions are alternately arranged.

[0019] In some embodiments, the constraint component is of a split structure covering at least part of the surface of the corresponding battery unit.

[0020] In some embodiments, there is a predetermined gap between an inner surface of the outer cover and an outer surface of the constraint component.

[0021] In some embodiments, the predetermined gap ranges from 2 mm to 100 mm.

[0022] In some embodiments, the battery pack further includes:

[0023] a depression bar and a fastener, wherein the mounting portions are arranged between the depression bar and the fixed beam, and the fastener passes through the depression bar and the mounting portions and is fixed with the fixed beam to fix the mounting portions to the fixed beam.

[0024] In some embodiments, the battery pack further includes a sealing member, the sealing member is arranged between the outer cover and the box body to seal the open end of the box body.

[0025] In some embodiments, a bonding layer is arranged between the battery units on the bottommost layer and an inner bottom surface of the box body; and/or, a bonding layer is arranged between two adjacent battery units in each group of battery units; and/or

[0026] a bonding layer is arranged between the constraint component and the battery unit on the topmost layer.

[0027] In some embodiments, the battery unit includes:

[0028] a shell; and

[0029] an electrode assembly arranged in the shell, wherein the electrode assembly includes a first pole piece, a second pole piece, and a diaphragm arranged between the first pole piece and the second pole piece; and

[0030] wherein the electrode assembly is of a wound structure and is flat, the outer surface of the electrode assembly includes two flat surfaces, and the two flat surfaces are oppositely arranged along a height direction of the battery pack; or,

[0031] the electrode assembly is of a laminated structure, and the first pole piece and the second pole piece are stacked along a height direction of the battery pack.

[0032] According to another aspect of the present disclosure, a vehicle is provided, including:

[0033] the battery pack in the above embodiments; and

[0034] a vehicle body provided with the battery pack.

BRIEF DESCRIPTION OF THE ACCOMPANYING DRAWINGS

[0035] The drawings illustrated herein are used for providing a further understanding of the present disclosure and constitute a part of the present application, and the illustrative embodiments of the present disclosure and the descrip-

tions thereof are used for explaining the present disclosure and do not constitute an undue limitation to the present disclosure. In the drawings:

[0036] FIG. 1 is a decomposed schematic diagram of some embodiments of a battery pack of the present disclosure;

[0037] FIG. 2 is a structural schematic diagram of the battery pack as shown in FIG. 1 after an outer cover is opened;

[0038] FIG. 3 is a section view of the battery pack as shown in FIG. 1 along an xz plane;

[0039] FIG. 4 is a partial section view of an internal structure of the battery pack as shown in

[0040] FIG. 2;

[0041] FIG. 5 is a structural schematic diagram of the battery pack provided with a depression bar and a sealing member;

[0042] FIG. 6 is a decomposed schematic diagram of other embodiments of the battery pack of the present disclosure;

[0043] FIG. 7 is a structural schematic diagram of the battery pack as shown in FIG. 6 after the outer cover is opened;

[0044] FIG. 8 is a decomposed schematic diagram of some embodiments of a battery unit in the battery pack;

[0045] FIG. 9 is a section view of a wound electrode assembly of the battery pack along the xz plane in FIG. 8;

[0046] FIG. 10 is a section view of a stacked electrode assembly of the battery pack along the xz plane in FIG. 8.

REFERENCE SIGNS

[0047] 1, box assembly; 11, box body; 111, first flange; 12, fixed beam; 121, first mounting hole; 13, accommodation cavity;

[0048] 2, battery unit; 20A, first group of battery units; 20B, second group of battery units; 21, shell; 22, electrode assembly; 221, first pole piece; 222, second pole piece; 223, diaphragm; 224, flat surface; 23, adapter piece; 24, cover plate assembly; 241, cover plate; 242, first electrode terminal; 243, second electrode terminal;

[0049] 3, constraint component; 3A, first constraint component; 3B, second constraint component; 31, limiting portion; 32, mounting portion; 321, mounting block; 322, second mounting hole;

[0050] 4, outer cover; 41, second flange;

[0051] 5, fastener; 6, depression bar; 7, sealing member.

DETAILED DESCRIPTION OF THE PREFERRED EMBODIMENTS

[0052] The present disclosure is described in detail below. In the following paragraphs, different aspects of the embodiments are defined in more detail. Aspects so defined can be combined with any other one or more aspects, unless clearly indicated that they are not combinable. In particular, any feature that is considered to be preferred or advantageous can be combined with the other one or more features that are considered to be preferred or advantageous.

[0053] The terms “first”, “second” and the like appearing in the present disclosure are merely for the convenience of description to distinguish different components having the same name, and do not indicate a sequential or primary and secondary relationship.

[0054] In addition, when an element is referred to as being “on” another element, the element can be directly on the other element, or can be indirectly on the other element and

one or more intermediate elements are inserted therebetween. In addition, when an element is referred to be “connected to” another element, the element can be directly connected to the other element or can be indirectly connected to the other element and one or more intermediate elements are inserted therebetween. The same reference sign denotes the same element below.

[0055] “A plurality of” appearing in the present disclosure refer to two or more (including two), and similarly, “multiple groups” refer to two or more groups (including two groups), and “multiple” refers to two or more (including two).

[0056] In order to clearly describe various orientations in the following embodiments, for example, various directions of a battery pack are defined in a coordinate system in FIG. 1, an x direction represents a length direction of the battery pack; a y direction is perpendicular to the x direction in the horizontal plane, and represents the width direction of the battery pack; the z direction is perpendicular to a plane formed by the x and y directions, and represents the height direction of the battery pack, when the battery pack is installed on a vehicle, the height direction of the battery pack is parallel to the vertical direction, and the vertical direction mentioned herein allows a certain angular deviation relative to the theoretical vertical direction. Based on this orientation definition, “upper”, “lower”, “top” and “bottom” are relative to the height direction.

[0057] In some embodiments, the present disclosure provides a vehicle including a vehicle body and a battery pack, and the battery pack is arranged in the vehicle body. The vehicle is a new energy vehicle, which can be a pure electric vehicle and can also be a hybrid vehicle or an extended-range vehicle, a driving motor is arranged in the vehicle body, the driving motor is electrically connected with the battery pack and is powered by the battery pack, and the driving motor is connected with wheels on the vehicle via a transmission mechanism so as to drive the vehicle to move. For example, the battery pack can be horizontally arranged at the bottom of the vehicle body and can be mounted in a top hooking and/or a bottom supporting manner.

[0058] In an actual use process, it is found that an outer cover of a battery pack has a large area and relatively poor rigidity, and a battery unit expands during charging and discharging, so that the outer cover of the battery pack is greatly deformed. The deformation of the outer cover of the battery pack will reduce the sealing performance of the outer cover and a box body, so that the external moisture enters the battery pack to cause a short circuit problem; and since the outer cover of the battery pack may jack the other components of a vehicle after deformation, when the battery pack needs to be removed from the vehicle for maintenance, it is difficult to be removed from the vehicle and reinstall on the vehicle.

[0059] Embodiments of the present disclosure provide a battery pack and a vehicle, which can effectively improve the sealing property of the battery pack.

[0060] Based on the above technical solutions, in the battery pack according to some embodiments of the present disclosure, by disposing the constraint component and fixing the same with the fixed beam, when the battery unit expands, a stable and effective pressing force can be provided for the battery unit to reduce the degree of expansion deformation of the battery unit; and moreover, since the constraint

component is provided, the deformation of the outer cover can be reduced, and the sealing property of the battery pack can be improved.

[0061] FIG. 1 to FIG. 5 are structural schematic diagrams of one embodiment of a battery pack of the present disclosure. The battery pack 100 includes a box assembly 1, a battery unit 2, a constraint component 3, and an outer cover 4.

[0062] The box assembly 1 includes a box body 11 and a fixed beam 12, the box body 11 has an open end, the fixed beam 12 is fixed in the box body 11, for example, the fixed beam 12 can be fixed to an inner bottom surface or a side wall of the box body 11. The battery unit 2 is arranged in the box body 11, the constraint component 3 covers the battery unit 2 and be in contact with the battery unit 2 on the topmost layer or reserve a predetermined gap, and the constraint component 3 is fixed with the fixed beam 12, and is configured to limit the expansion of the battery unit 2.

[0063] The outer cover 4 is arranged on one side of the constraint component 3 away from the box body 11, and is buckled to the open end of the box body 11 along the height direction of the battery pack for sealing the open end of the box body 11. The sealing here refers to a sealing connection between the outer cover 4 and the box body 11, which can prevent external liquid and water vapor from entering the battery pack, thereby improving the safety performance of the battery pack.

[0064] In the embodiment of the present disclosure, by disposing the constraint component 3 and fixing the same with the fixed beam 12, when the battery unit 2 expands, a stable and effective pressing force can be provided for the battery unit 2 to reduce the degree of expansion deformation of the battery unit 2; and moreover, since the constraint component 3 is provided, the deformation of the outer cover 4 can be reduced, and the sealing property of the battery pack can be improved. Furthermore, since the battery pack is provided with the constraint component 3, the deformation of the outer cover 4 can be reduced, when the battery pack is applied to the vehicle, the battery pack can still be smoothly removed or installed at the original mounting position after long-term use, so that the maintenance difficulty of the battery pack can be reduced, and the situation that an external force applied to a mounting structure member on the vehicle due to the deformation of the battery pack can also be prevented.

[0065] As shown in FIG. 1, the box body 11 is divided into a plurality of accommodation cavities 13 by the fixed beam 12, the battery pack includes a plurality of battery units 2, and the plurality of battery units 2 are divided into several groups of battery units in a plane perpendicular to the height direction, and several groups of the battery units 2 each has at least two battery units 2 and are respectively arranged in different accommodation cavities 13. For example, the sizes of the accommodation cavities 13 are adapted to the overall outline size of the battery units 2 in the same group.

[0066] In the present embodiment, the battery units 2 are divided into several groups, and the constraint component 3 is fixed with the fixed beams 12 for grouping the battery units 2, the fixing points between the constraint component 3 and the box body 11 are increased, therefore, the span between the fixing points is reduced, and the deformation resistance of the constraint component 3 can be improved. Compared with the conventional solution of constraining the entirety of all battery units through a cover body, the present

embodiment has the advantages that fixed constraint is separately applied to the periphery of each group of battery units 2, when the battery units expand, the constraint component 3 is not easy to be deformed, a stable pressing force can be further provided for the battery units 2 to prevent an increase in the size of the battery pack on the height direction, and it is also not easy to squeeze the outer cover 4 due to the deformation of the constraint component 3, thereby prolonging the service life of the battery pack.

[0067] Moreover, the battery units 2 are divided into several groups, when part of the battery units 2 work to generate a large amount of heat leading to thermal runaway, the diffusion of the heat toward the battery units 2 of other groups can be relieved, thereby improving the working safety of the battery pack, even if a part of the battery units 2 cannot be used normally, the battery pack can be used with reduced power.

[0068] As shown in FIG. 1, the battery pack includes a plurality of fixed beams 12, and the fixed beams 12 are arranged on both sides of each group of battery units 2 along a grouping direction in which the battery units 2 are divided into several groups. The fixed beams 12 are arranged not only in a passage formed by the adjacent groups of battery units 2, but also on one side of the battery units 2 in the outermost group close to the inner wall of the box body 11. The fixed beam 12 can be designed into a continuous structure on its own extension direction and can also be designed into a segmented structure.

[0069] The groups of battery units 2 can be fixed on the both sides along the grouping direction in the structure, in order to apply a more stable constraint force to the battery units 2, thereby improving the constraint effect on the group of battery units 2, and the expansion of the battery units can be further limited to prolong the service life of the battery pack.

[0070] For example, one layer or multiple layers of battery units 2 are stacked along the height direction, for example, two layers are provided in FIG. 1. The battery units 2 are divided into a plurality of columns along the grouping direction, and the battery units 2 in each column of battery units 2 are connected in parallel or in series through a bus bar, for two adjacent column of battery units 2 with electrode terminals facing each other, a gap is disposed between two adjacent columns of battery units 2.

[0071] For example, the distance between adjacent fixed beams 12 is configured to accommodate two columns of battery units 2 at most. In this way, the span between the adjacent fixed beams 12 can be reduced as much as possible, more fixing points are available between the constraint components 3 and the fixed beams 12, the deformation resistance of the constraint component 3 can be improved, and the constraint reliability on each group of battery units 2 can be improved.

[0072] In a front view as shown in FIG. 2, three fixed beams 12 extending along the width direction of the battery pack are arranged in the box body 11, and can be fixed to the inner bottom surface of the box body 11, the intermediate fixed beam 12 is located between two groups of battery units 2, the fixed beams 12 on both sides are arranged in the vicinity of the inner side wall of the box body 11, the space inside the box body 11 is divided into two accommodation cavities 13, wherein the first group of battery units 20A is placed in one accommodation cavity 13 (located on the left side in FIG. 1), and the first group of battery units 20A

includes only one column of battery units **2**; the second group of battery units **20B** is placed in the other accommodation cavity **13** (located on the right side in FIG. 1), and the second group of battery units **20B** includes two columns of battery units **2** arranged side by side along the length direction at intervals. Each column of battery units **2** includes a plurality of battery units **2** arranged side by side along the width direction in sequence, the side faces of the two adjacent battery units **2** are in contact with each other, and two layers of battery units **2** are stacked on the height direction.

[0073] The extension direction of the fixed beams **12** is perpendicular to the grouping direction of the battery units **2**, so that the internal structure of the battery pack more compact. As shown in FIG. 1, a plurality of battery units **2** are grouped along the length direction of the battery pack, the fixed beams **12** extend along the width direction of the battery pack, this arrangement mode is conducive to dividing the battery units **2** into more groups to increase the fixing points between the constraint component **3** and the box body **11**, and the overall length-width ratio of each group of battery units **2** can be reduced, so that the constraint rigidity of the constraint component **3** on each group of battery units **2** on the length and width directions is balanced, and the constraint reliability is improved.

[0074] Optionally, a plurality of battery units **2** are divided into several groups along the width direction of the battery pack, and the fixed beams **12** extend along the length direction of the battery pack. Or the plurality of battery units **2** can also be divided into several groups simultaneously along the length direction and the width direction of the battery pack, and the fixed beams **12** forms a latticed structure.

[0075] For the specific structure of the fixed beam **12**, a solid fixed beam or a hollow fixed beam can be used, and the cross section thereof can be rectangular, trapezoidal or C-shaped or the like, the upper surface thereof can be set as a plane to fix the constraint component to the upper surface of the fixed beam **12**, and optionally, the constraint component **3** can also be fixed to the side face of the fixed beam **12**.

[0076] In the decomposed schematic diagram as shown in FIG. 8, each battery unit **2** includes: a shell **21** and an electrode assembly **22** arranged in the shell **21**, and the shell **21** can have a hexahedral shape or other shapes and has an opening. The electrode assembly **22** is accommodated in the shell **21**. A cover plate assembly **24** covers the opening of the shell **21**. The cover plate assembly **24** includes a cover plate **241** and two electrode terminals arranged on the cover plate, and the two electrode terminals are respectively a first electrode terminal **242** and a second electrode terminal **243**. The first electrode terminal **242** can be a positive electrode terminal, and the second electrode terminal **243** can be a negative electrode terminal. In other embodiments, the first electrode terminal **242** can also be a negative electrode terminal, and the second electrode terminal **243** is a positive electrode terminal. An adapter piece **23** is arranged between the cover plate assembly **24** and the electrode assembly **22**, and the lugs of the electrode assembly **22** are electrically connected with the electrode terminals on the cover plate **241** through the adapter piece **23**. In the present embodiment, two adapter pieces **23** are disposed, namely, a positive electrode adapter piece and a negative electrode adapter piece, respectively.

[0077] As shown in FIG. 8, two electrode assemblies **22** are arranged in the shell **21**, and the two electrode assemblies **22** are stacked along the height direction (the z direction) of the battery unit **2**, wherein the height direction of the battery unit **2** is consistent with the height direction of the battery pack. Of course, in other embodiments, only one electrode assembly **22** is arranged in the shell **21**, or three or more electrode assemblies **22** are arranged in the shell **21**. A plurality of electrode assemblies **22** are stacked along the height direction (the z direction) of the battery unit **2**.

[0078] As shown in FIG. 9 and FIG. 10, the electrode assembly **22** includes a first pole piece **221**, a second pole piece **222**, and a diaphragm **223** arranged between the first pole piece **221** and the second pole piece **222**. The first pole piece **221** can be a positive pole piece, and the second pole piece **222** is a negative pole piece. In other embodiments, the first pole piece **221** can also be a negative pole piece, and the second pole piece **222** is a positive pole piece. The diaphragm **223** is an insulator located between the first pole piece **221** and the second pole piece **222**. The active substance of the positive pole piece can be coated on a coating area of the positive pole piece, and the active substance of the negative pole piece can be coated on the coating area of the negative pole piece. A portion extending from the coating area of the positive pole piece serves as a positive electrode lug; and a portion extending from the coating area of the negative pole piece serves as a negative electrode lug. The positive electrode lug is connected to the positive electrode terminal on the cover plate assembly **24** through the positive electrode adapter piece, and likewise, the negative electrode lug is connected to the negative electrode terminal on the cover plate assembly **24** through the negative electrode adapter piece.

[0079] As shown in FIG. 9, the electrode assembly **22** is of a wound structure. The first pole piece **221**, the diaphragm **223** and the second pole piece **222** are all of strip-shaped structure, the first pole piece **221**, the diaphragm **223** and the second pole piece **222** are sequentially stacked and wound for two or more circles to form the electrode assembly **22**, and the electrode assembly **22** is flat. When the electrode assembly **22** is fabricated, the electrode assembly **22** can be directly wound into a flat shape, or can be wound into a hollow cylindrical structure at first and then is flattened after being wound. FIG. 9 is a schematic diagram showing the outline of the electrode assembly **22**, the outer surface of the electrode assembly **22** includes two flat surfaces **224**, and the two flat surfaces **224** are oppositely arranged along the height direction (the z direction) of the battery unit **2**. The electrode assembly **22** is substantially of a hexahedral structure, and the flat surface **224** is substantially parallel to the winding axis and is the largest outer surface. The flat surface **224** can be a relatively flat surface and is not required to be a strict plane.

[0080] As shown in FIG. 10, the electrode assembly **22** is of a laminated structure, that is, the electrode assembly **22** includes a plurality of first pole pieces **221** and a plurality of second pole pieces **222**, and the diaphragms **223** are arranged between the first pole pieces **221** and the second pole pieces **222**. The first pole pieces **221** and the second pole pieces **222** are stacked along the height direction (the z direction) of the battery unit **2**.

[0081] The electrode assembly **22** inevitably expands along the thickness direction of the pole pieces during charging and discharging, the amount of expansion of each

pole piece is superimposed, the amount of expansion accumulated on the height direction is larger than that of the other directions, in the embodiment of the present disclosure, by increasing the fixing points between the constraint member 3 and the box body 11, the direction having the maximal amount of expansion of the battery unit 2 can be constrained to prevent the deformation of the battery pack, thereby prolonging the service life of the battery pack.

[0082] As shown in FIG. 3, there is a predetermined gap L between an inner surface of the outer cover 4 and an outer surface of the constraint component 3. By reserving an expansion space for the battery units 2, a force generated after the deformation of the constraint component 3 can be prevented from being transmitted to the outer cover 4 to force the outer cover 4 to generation deformation as well; furthermore, even if the battery unit 2 expands, such that the constraint component 3 is deformed to contact with the top cover 4, the outer cover 4 can further constrain the deformation of the constraint component 3 and the expansion of the battery unit 2. For example, for different sizes of battery packs, the predetermined gap ranges from 2 mm to 100 mm.

[0083] As shown in FIG. 1 and FIG. 2, the battery pack can include a plurality of constraint components 3, and the constraint components 3 respectively cover different groups of battery units 2. In the present embodiment, by using a plurality of constraint components 3 to respectively constrain different groups of battery units 2, fixed constraint can be independently applied to each group of battery units 2, thereby reducing the covering surface of the constraint component 3, and improving the self-stiffness to prevent easy deformation, so as to provide a stable and reliable constraint force. Furthermore, when the expansion of a certain group of battery units 2 is greater, which results in deformation of the same constraint component 3, the influence on the other groups of battery units 2 can be avoided, and the working reliability and the service life of the battery pack can be improved.

[0084] Specifically, each constraint component 3 includes a limiting portion 31 and two mounting portions 32. Wherein the limiting portion 31 covers the same group of battery units 2. The two mounting portions 32 are respectively connected to the both sides of the limiting portion 31 along the grouping direction of the battery units 2 and are respectively fixed with the fixed beams 12 on both sides of the same group of battery units 2 along the grouping direction. The constraint component 3 can be formed by bending a flat plate.

[0085] As shown in FIG. 2, the limiting portion 31 completely covers the top faces of the same group of battery units 2, so that the constraint force on the battery units 2 can be improved, and the deformation resistance of the constraint component 3 can be enhanced.

[0086] In the embodiment, by providing a plurality of independent constraint components 3, the groups of battery units 2 can be respectively constrained, the constraints on each groups of battery units 2 are completely independent, and the disassembly and assembly of the respective constraint components 3 does not affect each other. When the groups of battery units 2 have different heights, the mounting of the constraint components 3 is not affected. If the amount of expansion in an individual group of battery units 2 is relatively large, only the corresponding constraint component 3 is deformed, and the deformation force is not transmitted to the other constraint components 3. Moreover,

when the individual group of battery units 2 is faulty and needs to be maintained and replaced by opening the cover, only the corresponding constraint component 3 needs to be operated without disassembling the other constraint components 3.

[0087] As shown in FIG. 3, the whole limiting portion 31 protrudes relative to the mounting portion 32 toward a direction away from the battery units 2. Such a structure can not only reduce the arrangement height of the fixed beam 12 but also ensure the strength of the fixed beam 12, and when the mounting portion 32 and the fixed beam 12 are fixed by using a fastener 5, the fastener 5 can be prevented from protruding from the top face of the limiting portion 31, and the height of the battery pack can be reduced.

[0088] As shown in FIG. 3 and FIG. 4, there is only one fixed beam 12 arranged between two adjacent groups of battery units 2, each of the two adjacent mounting portions 32 fixed with the fixed beam 12 includes a plurality of mounting blocks 321, the plurality of mounting blocks 321 are arranged along the extension direction of the fixed beam 12 at intervals, and the plurality of mounting blocks 321 of the two adjacent mounting portions 32 are alternately arranged. For example, the mounting block 321 can have a rectangular, trapezoidal or triangular configuration. The structure can make the constraint components 3 corresponding to the two adjacent groups of battery units 2 to be fixed by one fixed beam 12, therefore the space can be saved, and the energy density of the battery pack can be improved. Optionally, two fixed beams 12 are arranged between the two adjacent groups of battery units 2, and two constraint components 3 are respectively fixed on two fixed beams 12.

[0089] Specifically, as shown in FIG. 1, in order to fix the outer cover 4 with the box body 11, a first flange 111 is arranged around the open end of the box body 11, a second flange 41 is arranged around the outer cover 4, and the first flange 111 and the second flange 41 can be fixed by bonding or fastener connection. In order to fix the constraint component 3 with the fixed beam 12, the mounting portion 32 is provided with a plurality of second mounting holes 322 spaced apart along the extension direction of the fixed beam 12, the top of the fixed beam 12 is provided with a plurality of first mounting holes 121 spaced apart along its own extension direction, and the fastener 5 passes through the second mounting holes 322 and the first mounting holes 121 to fix the constraint component 3 with the fixed beam 12.

[0090] As shown in FIG. 5, the battery pack of the present disclosure can further include: a depression bar 6 arranged between the mounting portion 32 and the fixed beam 12, the depression bar 6 can adopt a long strip-like structure, and the depression bar 6 is provided with a hole for ensuring the fastener 5 to pass through. The depression bar 6 with a proper thickness can be selected during the assembly to adjust the assembly gap, after the constraint component 3 and the fixed beam 12 are fixed by the fastener 5, a proper assembly gap can be kept between the constraint component 3 and the battery unit 2, so as to prevent the constraint component 3 from generating a larger pressing force on the battery unit 2, thereby prolonging the service life of the battery pack.

[0091] Optionally, the depression bar 6 can also be arranged between the fastener 5 and the top face of the mounting portion 32. For example, when the fastener 5 is a screw, the depression bar 6 is arranged between the screw

head and the top face of the mounting portion 32 to improve the fixing reliability of the fastener 5.

[0092] Still referring to FIG. 5, in order to ensure the sealing property of an internal space of the battery pack, and to prevent the external liquid or water vapor from entering the battery pack to affect the working performance of the battery unit 2, the battery pack of the present disclosure can further include a sealing member 7 arranged between the outer cover 4 and the box body 11, and the sealing member 7 can have a long strip-like structure or a rectangular annular structure. The sealing member 7 is provided with a hole for ensuring the fastener 5 to pass through. The sealing member can be made of silicone rubber or other materials. When the battery pack is used in a vehicle, the sealing member can also absorb vibration transmitted to the battery pack during the work of the vehicle.

[0093] In some embodiments, in order to improve the fixing reliability of the battery unit 2 and to prevent the battery unit 2 from shaking, a bonding layer is arranged between the battery unit 2 on the bottommost layer and an inner bottom surface of the box body 11; and/or, a bonding layer is arranged between two adjacent battery units 2 in each group of battery units 2; and/or, a bonding layer is arranged between the constraint component 3 and the battery unit 2 on the topmost layer. For the battery pack provided with only a single layer of battery unit 2, the battery unit 2 on the bottommost layer and the battery unit 2 on the topmost layer are the same layer of battery unit 2.

[0094] FIG. 6 and FIG. 7 are structural schematic diagram of other embodiments of a battery pack of the present disclosure. The difference between the battery pack 200 and the battery pack 100 shown in FIG. 1 to FIG. 4 lies in that the constraint component 3 can adopt a split structure and cover part of surfaces of the battery unit 2.

[0095] The constraint component 3 is of a split structure and arranged at least along one of the length direction and the width direction, the constraint component 3 adopts a split structure and covers at least part of the surface of the corresponding battery unit 2. As shown in FIG. 6, the constraint component 3 for covering the first group of battery units 20A includes a first constraint component 3A and a second constraint component 3B, and the limiting portions 31 of the first constraint component 3A and the second constraint component 3B can be arranged along the length direction at intervals and only cover part of the surfaces of the group of battery units 2. The mounting portion 32 of the first constraint component 3A continuously extends along the width direction, and the mounting portion 32 of the second constraint component 3B includes a plurality of mounting blocks 321 arranged along the width direction at intervals. The constraint component 3 for covering the second group of battery units 20B adopts an integral structure. FIG. 7 shows a schematic diagram of fixing the first constraint component 3A and the second constraint component 3B to the fixed beam 12 by the fastener 5.

[0096] The embodiment has the advantages that, due to the influence of the dimensional tolerance of the battery units 2 and the accuracy of the stacking arrangement, the tops of the battery units 2 in the same group may have a height difference, the split constraint component 3 is used to reduce the processing requirements for the height size of a side plate of the limiting portion, and the assembly is also easy; furthermore, the split constraint component 3 can save

the material; and in addition, the heat dissipation of the battery unit 2 is facilitated by partially covering the surfaces of the battery units 2.

[0097] On this basis, the temperature adjustment can be performed according to the working requirements of the battery pack, and the box assembly 1 can further include a temperature control component, the temperature control component is arranged in a bottom area of the box body 11, the temperature control component is used for performing temperature adjustment on the battery unit 2 from the bottom, for example, in order to take away the heat generated in the working process of the battery unit 2, the battery unit 2 can be cooled; or when the battery pack is used in a low temperature area, the battery unit can be heated.

[0098] In the embodiments of the present disclosure, by disposing the heat-conducting fixed beam 12 and the constraint component 3, and covering the tops and the sides of the groups of battery units 2, when the temperature control component performs the temperature adjustment at the bottom of the box body 11, the temperature can be sequentially transmitted to the fixed beam 12 and the constraint component 3, therefore the conduction path of the temperature control component to regulate the temperature of the battery unit 2 is changed, the temperature distribution in the accommodation cavity along the height direction can be balanced, the temperature difference between the battery units 2 in the upper and lower areas can be reduced, and the temperature uniformity of the battery units 2 is improved, thereby improving the consistency of discharging depths.

[0099] In some embodiments, a device using a secondary battery is also provided in the present disclosure, and the battery includes the battery pack of the above embodiments. The device using secondary battery can include vehicle, ship, drone, etc. Since the sealing property of the battery pack can be improved, the battery pack can still be smoothly removed or installed at the original mounting position after long-term use, so that the maintenance difficulty of the battery pack can be reduced, and the situation that an external force applied to a mounting structure member on the device due to the deformation of the battery pack can also be prevented.

[0100] The battery pack and the vehicle provided by the present disclosure are described in detail above. The principles and the embodiments of the present disclosure have been described herein by using specific embodiments, and the description of the above embodiments is only used for assisting to understand the method of the present disclosure and its core idea. It should be noted that those of ordinary skill in the art can make several improvements and modifications to the present disclosure without departing from the principles of the present disclosure, and these improvements and modifications shall also fall within the protection scope of the claims of the present disclosure.

What is claimed is:

1. A battery pack, comprising:

- a box assembly, comprising a box body and a fixed beam, wherein the fixed beam is fixed in the box body;
- a battery unit, arranged in the box body;
- a constraint component covering the battery unit and fixed with the fixed beam; and
- an outer cover, arranged on one side of the constraint component away from the box body to seal an open end of the box body.

2. The battery pack according to claim 1, wherein the box body is divided into a plurality of accommodation cavities by the fixed beam, the battery pack comprises a plurality of battery units, and the plurality of battery units are divided into several groups of battery units in a plane perpendicular to a height direction of the battery pack, and several groups of the battery units each has at least two battery units and are respectively arranged in different accommodation cavities.

3. The battery pack according to claim 2, wherein the box assembly comprises a plurality of fixed beams arranged on both sides of each group of battery units along a grouping direction in which the battery units are divided into several groups.

4. The battery pack according to claim 2, wherein, the plurality of battery units are divided into several groups along a length direction of the battery pack, the fixed beam extends along a width direction of the battery pack; and/or

the plurality of battery units are divided into several groups along a width direction of the battery pack, and the fixed beam extends along a length direction of the battery pack.

5. The battery pack according to claim 2, comprising a plurality of constraint components, wherein the constraint components respectively cover different groups of the battery units.

6. The battery pack according to claim 5, wherein the constraint component comprises:

a limiting portion covering the same group of battery units; and

two mounting portions, respectively connected to the both sides of the limiting portion along a grouping direction of the battery units, wherein the two mounting portions are respectively fixed with the fixed beams on the both sides of the same group of battery units.

7. The battery pack according to claim 6, wherein the whole limiting portion protrudes relative to the mounting portion toward a direction away from the battery unit.

8. The battery pack according to claim 6, wherein there is only one fixed beam arranged between two adjacent groups of battery units, each of the two adjacent mounting portions fixed with the fixed beam comprises a plurality of mounting blocks, the plurality of mounting blocks are arranged along an extension direction of the fixed beam at intervals, and the plurality of mounting blocks of the two adjacent mounting portions are alternately arranged.

9. The battery pack according to claim 1, wherein the constraint component is of a split structure covering at least part of the surface of the corresponding battery unit.

10. The battery pack according to claim 1, wherein there is a predetermined gap between an inner surface of the outer cover and an outer surface of the constraint component.

11. The battery pack according to claim 10, wherein the predetermined gap ranges from 2 mm to 100 mm.

12. The battery pack according to claim 6, further comprising:

a depression bar and a fastener, wherein the mounting portions are arranged between the depression bar and the fixed beam, and the fastener passes through the depression bar and the mounting portions, and is fixed with the fixed beam to fix the mounting portions to the fixed beam.

13. The battery pack according to claim 1, further comprising a sealing member, wherein the sealing member is arranged between the outer cover and the box body to seal the open end of the box body.

14. The battery pack according to claim 2, wherein,

a bonding layer is arranged between the battery units on the bottommost layer and an inner bottom surface of the box body; and/or,

a bonding layer is arranged between two adjacent battery units in each group of battery units; and/or,

a bonding layer is arranged between the constraint component and the battery units on the topmost layer.

15. The battery pack according to claim 1, wherein the battery unit comprises:

a shell; and

an electrode assembly arranged in the shell, wherein the electrode assembly comprises a first pole piece, a second pole piece, and a diaphragm arranged between the first pole piece and the second pole piece; and

wherein the electrode assembly is of a wound structure and is flat, the outer surface of the electrode assembly comprises two flat surfaces, and the two flat surfaces are oppositely arranged along a height direction of the battery pack; or,

the electrode assembly is of a laminated structure, and the first pole piece and the second pole piece are stacked along a height direction of the battery pack.

16. A vehicle, comprising:

the battery pack according to claim 1; and

a vehicle body provided with the battery pack.

17. A device of using a secondary battery, and the battery comprising a battery pack according to claim 1.

* * * * *