



US 20210354279A1

(19) **United States**

(12) **Patent Application Publication**

**Ricordi et al.**

(10) **Pub. No.: US 2021/0354279 A1**

(43) **Pub. Date: Nov. 18, 2021**

(54) **GAS-OPERATED FIXING TOOL AND METHOD OF OPERATING IT**

**Publication Classification**

(71) Applicant: **Illinois Tool Works Inc.**, Glenview, IL (US)

(51) **Int. Cl.**  
*B25C 1/14* (2006.01)  
*B25C 1/18* (2006.01)

(72) Inventors: **Christian Ricordi**, Glenview, IL (US);  
**Olivier Baudrand**, Glenview, IL (US)

(52) **U.S. Cl.**  
CPC . *B25C 1/14* (2013.01); *B25C 1/18* (2013.01)

(21) Appl. No.: **17/277,675**

(57) **ABSTRACT**

(22) PCT Filed: **Sep. 9, 2019**

Gas-operated fixing tool including a working chamber, a piston mounted slideably in the working chamber and comprising a driving rod of which a first longitudinal end is configured to drive a fixing element and of which a second longitudinal end is connected to a head which separates the working chamber into a first portion and into a second portion which is traversed by the rod, and at least one combustion chamber in which a mixture of air and fuel is intended to be burnt in order that combustion gases generate a rise in pressure that causes a movement of the piston in the working chamber, wherein the at least one combustion chamber is in fluid communication with the second portion in such a way that the rise in pressure causes the movement and the return of the piston into a rest position ready for firing a fixing element.

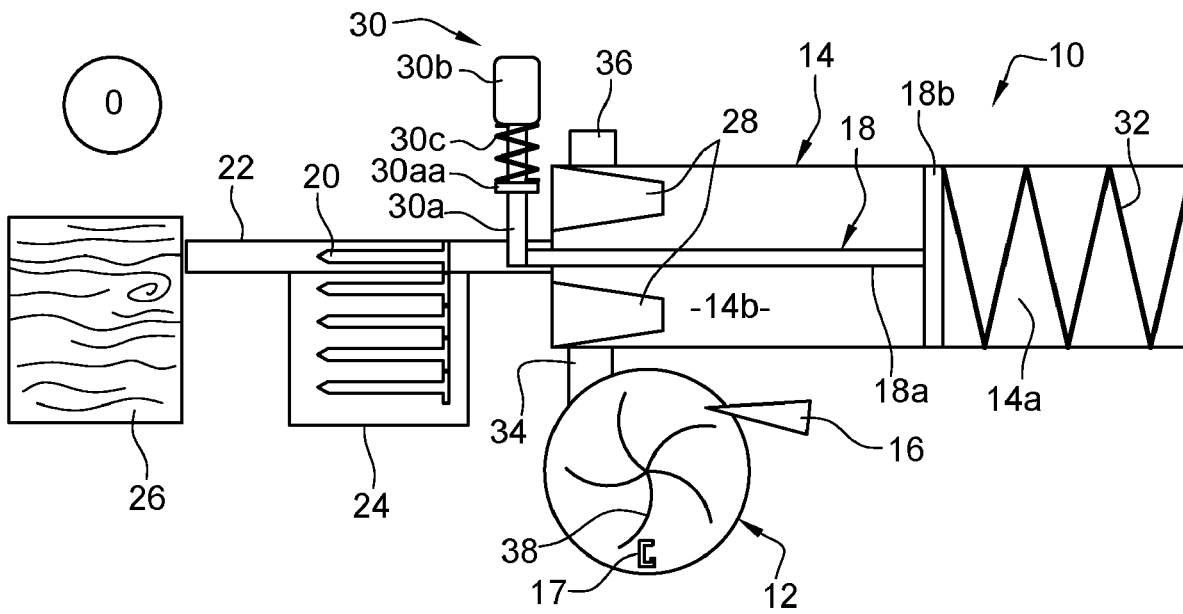
(86) PCT No.: **PCT/US2019/050171**

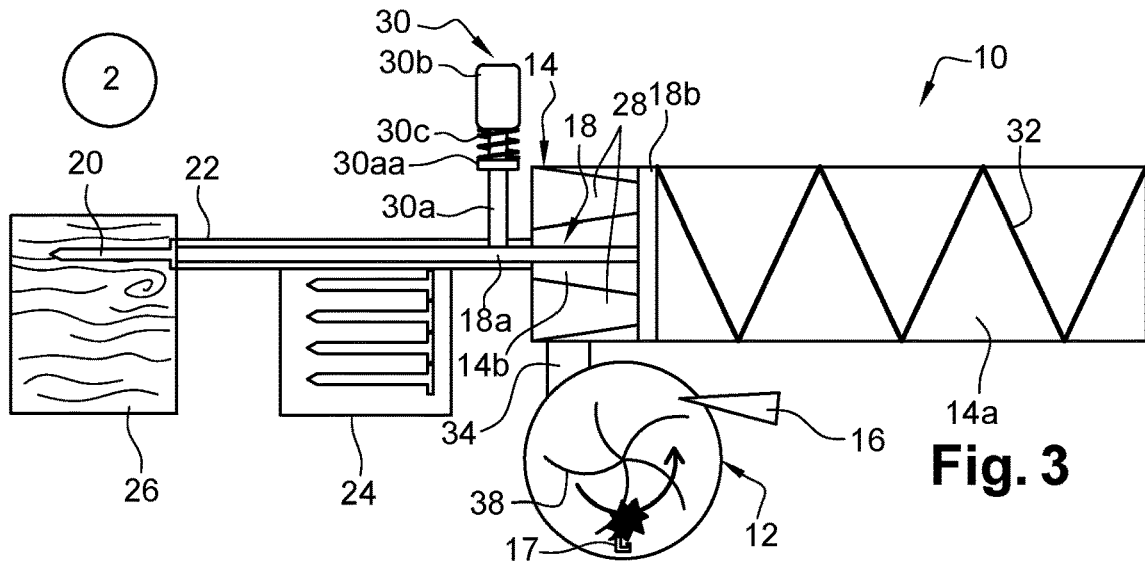
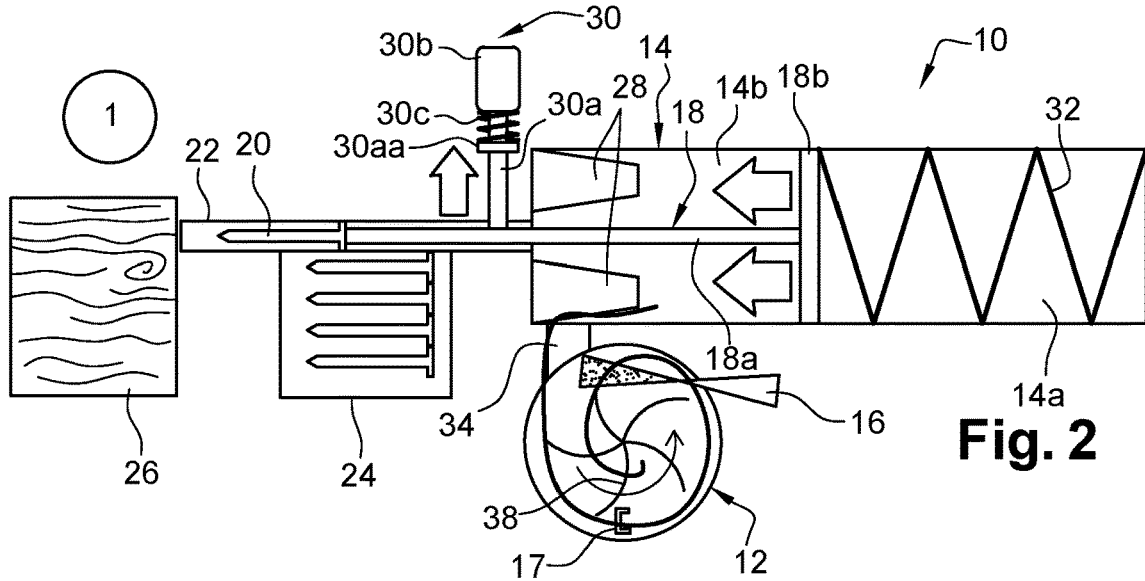
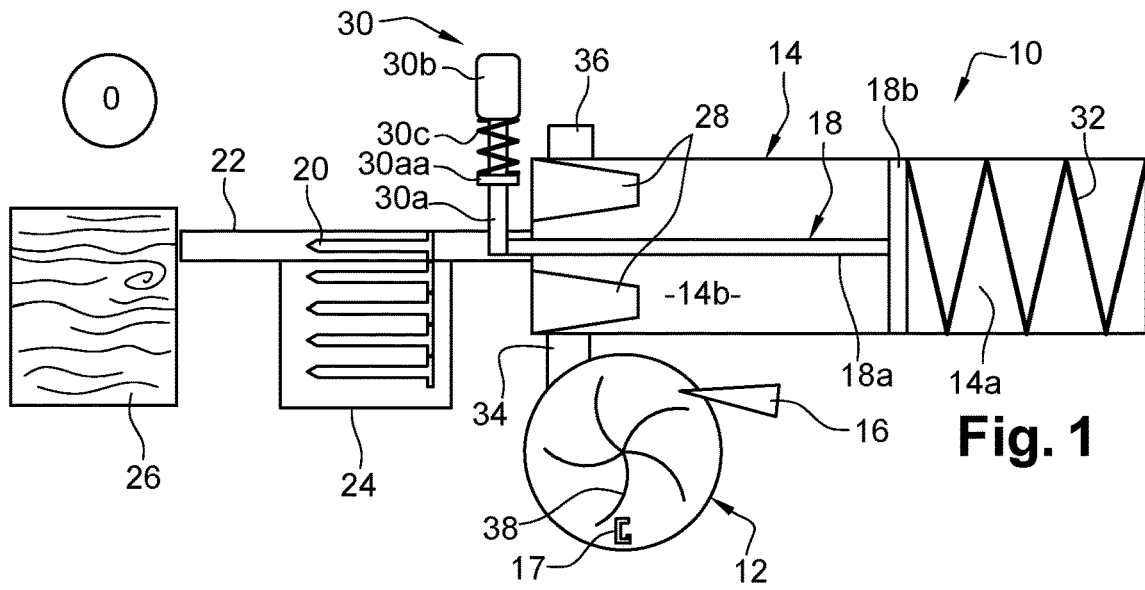
§ 371 (c)(1),

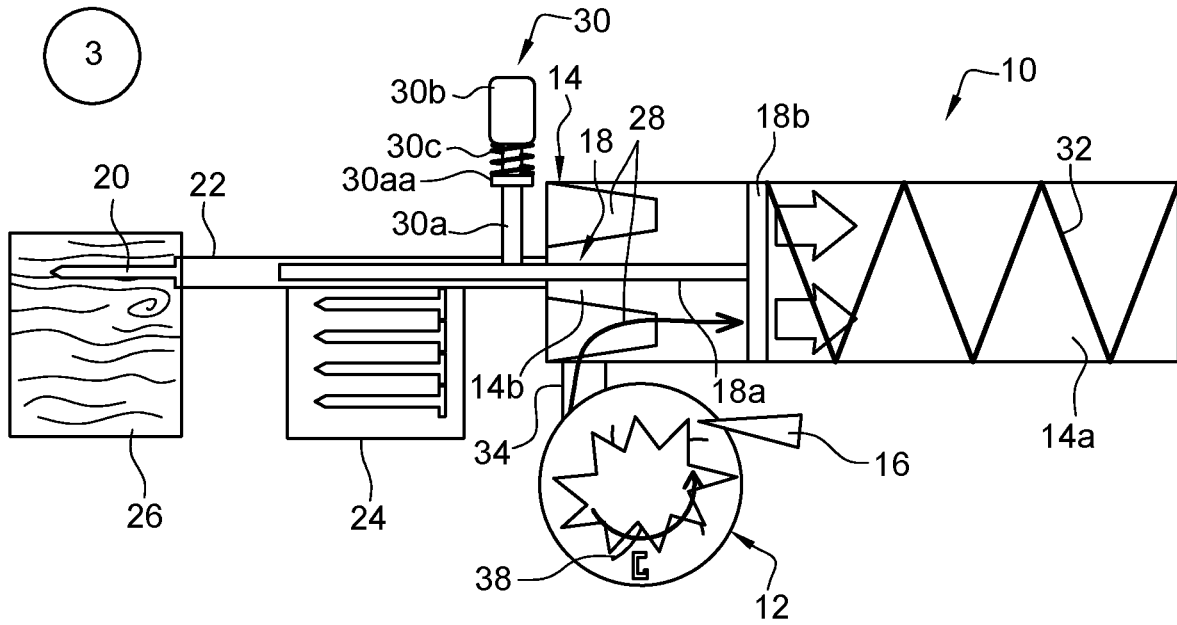
(2) Date: **Mar. 18, 2021**

(30) **Foreign Application Priority Data**

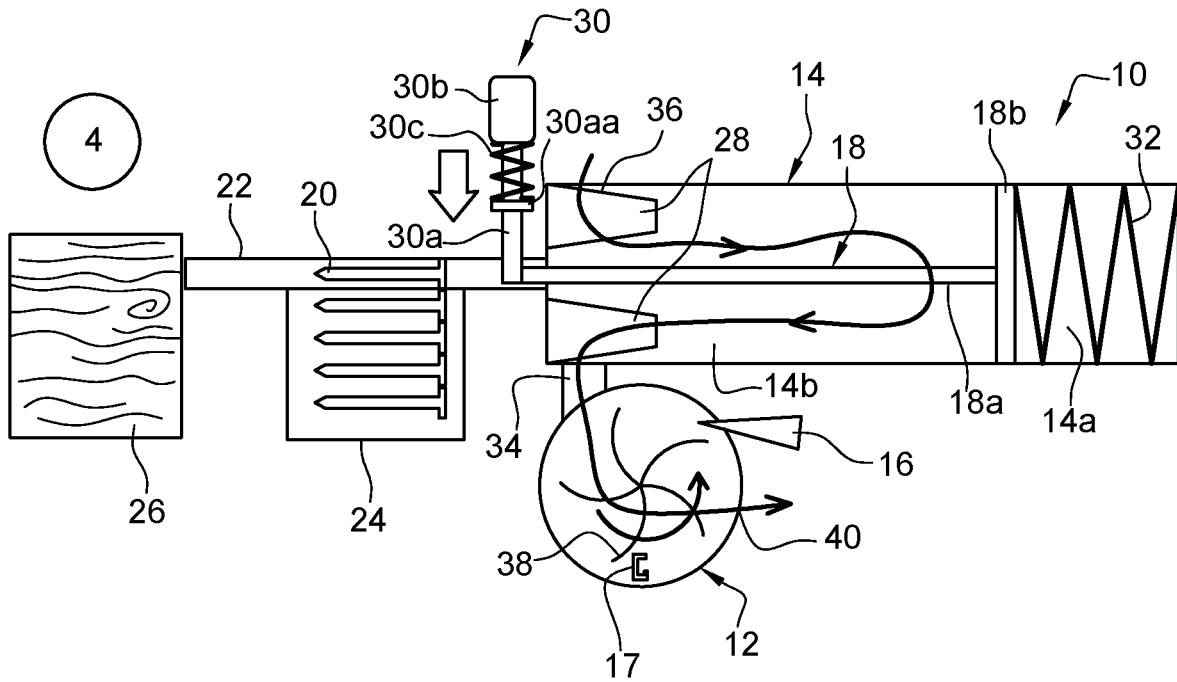
Oct. 1, 2018 (FR) ..... 1859058



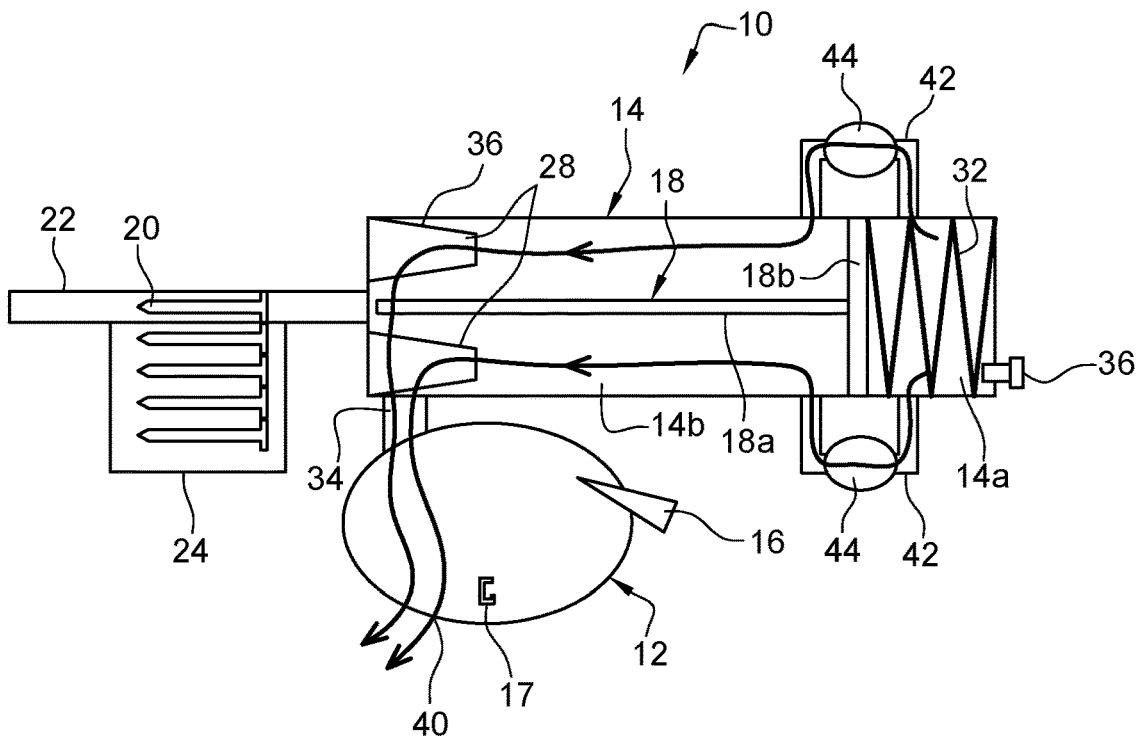




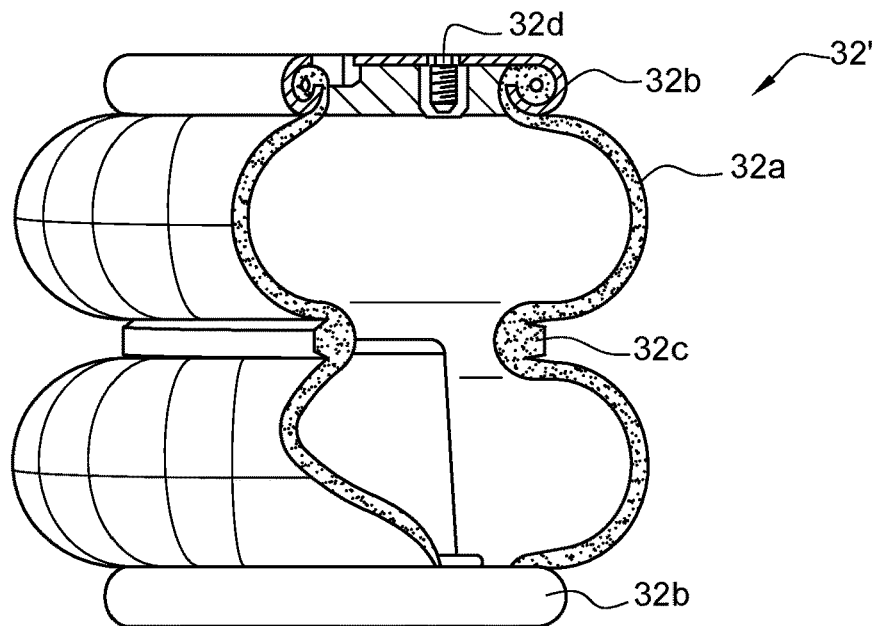
**Fig. 4**



**Fig. 5**



**Fig. 6**



**Fig. 7**

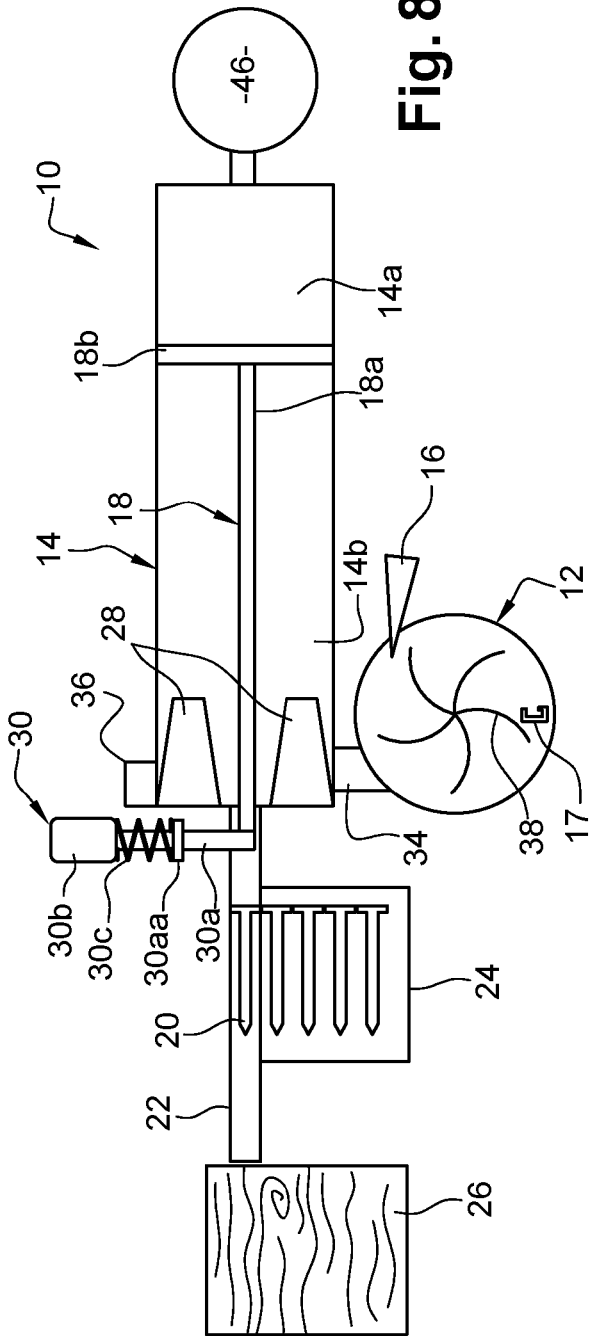


Fig. 8

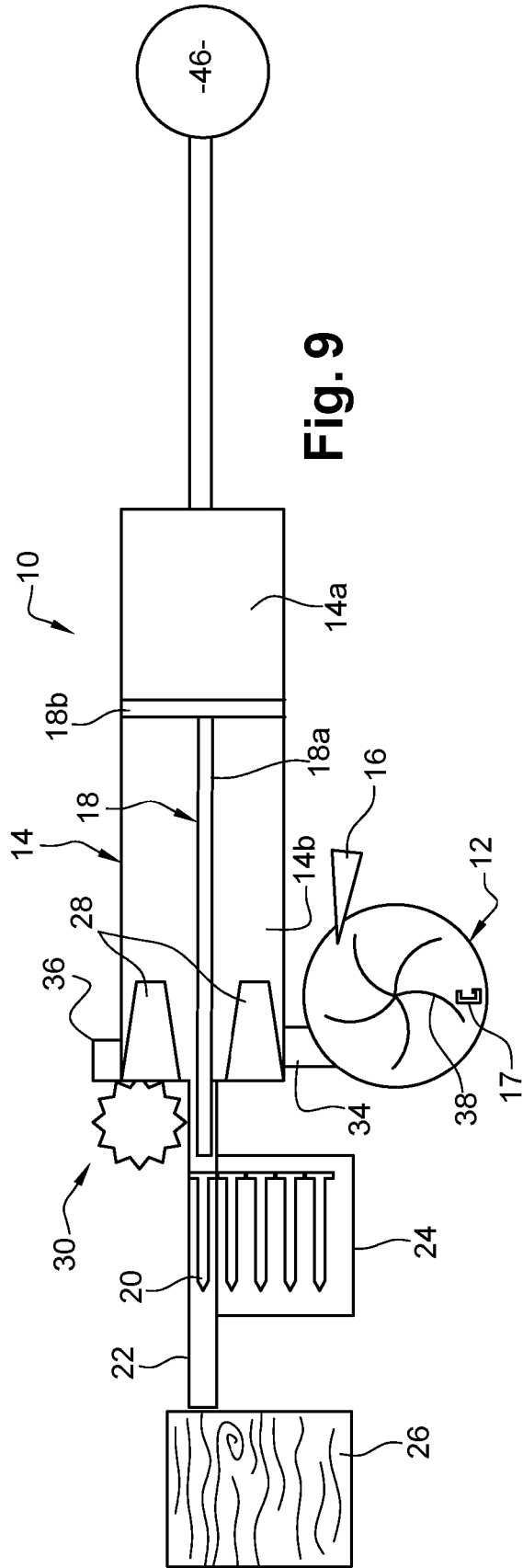


Fig. 9

## GAS-OPERATED FIXING TOOL AND METHOD OF OPERATING IT

### PRIORITY

**[0001]** This application claims priority to and the benefit of French Patent Application No. 1859058, filed Oct. 1, 2018, the entire contents of which are incorporated herein by reference.

### FIELD

**[0002]** The invention concerns a gas-operated fixing tool, such as a nail gun for example, and a method of operating it.

### BACKGROUND

**[0003]** The invention concerns so-called gas-operated fastening or fixing tools, that is to say tools including an internal combustion engine operating by ignition in a combustion chamber of an air-fuel mixture, the fuel being injected into the chamber by an injection device from a fuel container termed a gas cartridge. Tools of this kind are intended to drive fixing elements into substrate materials to fix components thereto. Gas-operated nail guns are nowadays in very widespread use. By way of fuel for an internal combustion engine there may be cited for example butane, propane, etc. in liquid and/or gas form.

**[0004]** A tool of this kind is generally portable and includes a casing in which is mounted the internal combustion engine for propelling a piston for driving a fixing element. A tool of this kind may also include an electrical power supply battery as well as a holding, manipulation and firing handle on which is mounted a trigger for actuating the tool.

**[0005]** A firing cycle comprises a plurality of steps such as the distribution of a quantity of fuel by the cartridge, the admission of the fuel into the chamber, the mixing of the fuel with air in the chamber, the ignition and combustion of the mixture to drive the piston, and the evacuation of the combustion gases from the chamber.

**[0006]** At present the piston is mounted in a working chamber and includes a drive rod a first longitudinal end of which is configured to drive a fixing element and a second longitudinal end of which is connected to a head that divides the working chamber into two portions. A first of these portions is intended to receive the combustion gases coming from the combustion chamber in order drive the piston from its rest position to its working or firing position. The piston rod passes through a second portion of the working chamber.

**[0007]** In this first (gas-operated) fixing tool technology the piston is returned automatically from its working position to its rest position. In fact, the reduced pressure generated in the first portion of the working chamber because of the firing and the movement of the piston is sufficient to exert a suction return force on the piston so that it returns to its rest position.

**[0008]** However, this type of gas-operated fixing tool has a disadvantage linked to the fact that firing quality is strongly linked to the climatic conditions in which the tool is used. In fact, the climatic conditions influence the combustion of the air-fuel mixture. The air that is mixed with the fuel comes from the surrounding air and the variation in the density of the air linked for example to the temperature or to the altitude can have a negative effect on the quality of the

combustion in the combustion chamber. Moreover, if the tool heats up because of a plurality of successive firings the performance of the internal combustion engine and therefore of the tool may decrease.

**[0009]** To solve this problem manufacturers of fixing tools also offer tools with no internal combustion engine. These fixing tools are configured to fire fixing elements by pneumatic or mechanical energy.

**[0010]** In the case of pneumatic actuation the aforementioned first portion of the working chamber is generally connected to a source of gas under pressure, such as compressed air. Feeding this first portion with gas under pressure causes the piston to move from its rest position to its working position and fires a fixing element.

**[0011]** In the case of mechanical actuation a compression spring is mounted in the first portion of the working chamber and is configured to urge the piston from its rest position to its working position to fire a fixing element.

**[0012]** This other (pneumatic or mechanical) fixing tool technology employs a gear motor, that is to say an electric motor associated with a reduction gear, to return the piston from its working position to its rest position. The gear motor and its power supply battery are heavy and bulky however.

**[0013]** The present invention proposes an improvement to the existing technologies that makes it possible to solve at least some of the problems referred to above.

### SUMMARY

**[0014]** The present invention concerns a gas-operated fixing tool, comprising:

**[0015]** a working chamber,

**[0016]** a piston mounted slideably in the working chamber and comprising a driving rod of which a first longitudinal end is configured to drive a fixing element and of which a second longitudinal end is connected to a head which separates the said working chamber into a first portion and into a second portion which is traversed by the said rod, and

**[0017]** at least one combustion chamber in which a mixture of air and fuel is intended to be burnt in order that combustion gases generate a rise in pressure which causes a movement of the piston in the working chamber,

characterized in that the said at least one combustion chamber is in fluid communication with the said second portion in such a way that the rise in pressure causes the movement and the return of the piston into a rest position ready for firing a fixing element.

**[0018]** The invention proposes an optimum compromise between the two technologies described above. The tool according to the invention may be considered to conform to the first technology since it is of the gas-operated type, that is to say comprises an internal combustion engine or to be more precise a combustion chamber in which an air-fuel mixture is intended to be burned and to generate combustion gases increasing the pressure in the combustion chamber. However, in contrast to the prior art, these combustion gases and this increase in pressure in the combustion chamber are not used for firing, that is to say for moving the piston from its rest position to its working position, but on the contrary to move the piston to its rest position. An internal combustion engine is lighter and less bulky than a gear motor and its power supply battery. Replacing the gear motor by an internal combustion engine is therefore advantageous. The

tool may furthermore utilize the second technology to fire a fixing element, that is to say that firing may be obtained using pneumatic or mechanical energy. In this case, even the climatic conditions are not the optimum for the operation of the internal combustion engine of the tool, these conditions will have no influence on firing a fixing element. In conclusion, the compromise proposed by the invention makes it possible to benefit from the advantages of the aforementioned two technologies without their disadvantages.

[0019] The tool according to the invention may include one or more of the following features or steps, separately or in combination:

- [0020] the tool is devoid of direct fluid communication between the said at least one combustion chamber and the said first portion;
  - [0021] the said first portion contains an elastically deformable member which is configured to:
    - [0022] be elastically compressed by the piston during its movement to its rest position, and
    - [0023] by elastic expansion, urge the said piston from its rest position to a working position and thus lead to a fixing element being fired;
  - [0024] the said first portion is in fluid communication with a pressurized and non-flammable gas source in order to ensure the movement of the piston from its rest position to a working position;
  - [0025] the tool comprises an element for blocking the piston in its rest position;
  - [0026] the said second portion comprises at least one elastic stop for damping the piston at the end of travel during a firing operation;
  - [0027] the said at least one combustion chamber comprises a propeller;
  - [0028] the said propeller is fixed in rotation;
  - [0029] the said propeller is free to rotate or configured to be driven in rotation by a motor;
  - [0030] the said at least one combustion chamber comprises a spark plug and is connected to a fuel cartridge;
  - [0031] the said second portion and/or the said at least one combustion chamber comprise or comprises a vent for fresh air venting and for optionally discharging combustion gases;
  - [0032] the said first and second portions are in fluid communication via at least one duct equipped with a valve and configured such that the pressurized air contained in the said first portion, and resulting from the movement of the piston to its rest position, is at least partially discharged into the said second portion or even into the said at least one combustion chamber.
- [0033] The present invention further concerns a method for operating a gas-operated fixing tool according to one of the preceding claims, characterized in that it comprises the steps of:
- [0034] a) moving the piston from its rest position to a working position and driving a fixing element by the rod of the piston,
  - [0035] b) igniting an air and fuel mixture in the said at least one combustion chamber and generating combustion gases causing a rise in pressure resulting in a movement of the piston to its rest position.
- [0036] The method according to the invention may include one or more of the following features or steps, separately or in combination:

[0037] before the step a), a step of releasing the piston and/or a step of supplying the first portion of the working chamber with a pressurized and non-flammable gas,

[0038] after the step b), a step of discharging the combustion gases from the said at least one combustion chamber by purging by means of ambient air or air from the said first portion,

[0039] after the step b), a step of blocking the piston in its rest position,

[0040] during the step a), supplying the said at least one combustion chamber by gases expelled from the said second portion owing to the movement of the piston from its rest position to its working position,

[0041] during the step a), setting the gases in rotation or creating turbulence in the said at least one combustion chamber.

#### BRIEF DESCRIPTION OF THE FIGURES

[0042] The invention will be better understood and other details, features and advantages of the present invention will become more clearly apparent on reading the following description given by way of nonlimiting example and with reference to the appended drawings, in which:

[0043] FIGS. 1 to 5 are highly diagrammatic part-sectional views of a gas-operated fixing tool according to the invention and illustrate steps of the method of operating it,

[0044] FIG. 6 is a view similar to those of FIGS. 1 to 5 showing a variant embodiment of the invention,

[0045] FIG. 7 is a partially cutaway diagrammatic perspective view of an elastically deformable member for a tool according to the invention, and

[0046] FIGS. 8 and 9 are views similar to those of FIGS. 1 to 5 showing other variant embodiments of the invention.

#### DETAILED DESCRIPTION

[0047] FIGS. 1 to 5 illustrate a first embodiment of a fixing tool 10 according to the present invention.

[0048] The fixing tool 10 is highly diagrammatically and partially represented in the drawings. This tool 10 includes a casing (not shown) in which is located an internal combustion engine equipped with at least two chambers: a combustion chamber 12 and a working chamber 14. A variant embodiment could include an additional precombustion chamber.

[0049] The combustion chamber 12 is intended to receive a mixture of air and fuel. Fuel 16 is fed via an injection member from a fuel gas cartridge (not shown). In practise the combustion chamber 12 receives an air-fuel mixture ignited by a spark plug 17 or the like.

[0050] A drive piston 18 is mounted in the working chamber 14 to slide from a rest position shown in FIG. 1 to a working position shown in FIG. 3 and vice-versa. Firing means movement of the piston 18 from its rest position to its working position and driving a fixing element 20, which is a nail in the example shown but could be of some other type, such as a clip for example.

[0051] The piston 18 includes a drive rod 18a a first longitudinal end of which is configured to drive a fixing element 20 and a second longitudinal end of which is connected to a head 18b that divides the working chamber 14 into a first portion 14a and a second portion 14b. The portions 14a, 14b are coaxial. The rod 18a passes through

the second portion **14b** and extends as far as a tip **22** of the tool through which the fixing element **20** is fired.

[0052] The fired fixing element **20** is extracted from a feed magazine **24** and is intended to be anchored into a substrate material **26** when it exits the tip **22** of the tool. Although this cannot be seen, the casing of the tool **10** includes a handle for holding and manipulating the tool. The handle is also used for firing by means of an actuator trigger mounted on it. All these components of gas-operated fixing tools are known to the person skilled in the art and therefore have not all been represented in the drawings.

[0053] The second portion **14b** of the working chamber **14** includes one or more elastic abutments **28** for damping the piston at the end of travel upon firing (FIG. 3).

[0054] The tool **10** further includes an element **30** for immobilizing the piston **18** in its rest position shown in FIG. 1. In the example shown this member **30** is located at the level of the tip **22** of the tool and comprises a mobile finger **30a**. This finger **30a** is mobile between a deployed position shown in FIGS. 1 and 5 and a retracted position shown in FIGS. 2 to 4. In the deployed position the finger **30a** extends in front of the free end of the rod **18a** of the piston **18**. This end bears on the finger **30a** which therefore immobilizes the piston **18** in its rest position. In the retracted position the finger **18** is retracted relative to the rod **18a** of the piston **18** which is therefore free to move in the working chamber **14**. The finger **30a** may be moved by an actuator (not shown) controlled by a controller (not shown) of the tool **10**. Here the finger **30a** is mounted to slide on a support **30b** and urged into its deployed position by a compression coil spring **30c** mounted around the finger **30a** and extending between the support **30b** and an annular flange **30aa** of the finger.

[0055] In the example shown firing is brought about by mechanical energy that here is supplied by an elastically deformable member **32** housed in the first portion **14a** of the working chamber.

[0056] The member **32** extends between the head **18b** of the piston **18** and a rear end of the working chamber **14** opposite the tip and is elastically deformable in compression in a direction parallel to the direction of movement of the piston **18**.

[0057] In the example shown this member **32** is diagrammatically represented as a compression coil spring but this embodiment is not limiting on the invention. FIG. 7 shows for example a variant embodiment of the member **32** that is formed by a bellows **32'**. The bellows **32'** comprises a tubular elastic membrane **32a** the axial ends of which are closed by transverse plates **32b**. The membrane **32a** is surrounded by one or more rings **32c** which define between them and with the plates **32b** compressible portions of the membrane. The bellows **32'** encloses a gas under pressure that can be injected via a port **32d** of one of the plates **32b**. The bellows **32'** functions in a similar way to a compression spring.

[0058] The member **32** is advantageously configured:

[0059] to be compressed elastically by the piston **18** when it moves to its working position, and

[0060] by elastic expansion, to urge the piston **18** from its rest position to a working position and thereby to fire a fixing element **20**.

[0061] In FIG. 1 the piston **18** is immobilized in its rest position by the element **30**. When the element **30** moves and the piston **18** is therefore released, the member **32** drives the piston **18** from its rest position to the working and firing

position (FIG. 2). The end of travel is defined by the abutments **28** which are able to bring about reverse elastic return of the piston (FIG. 3). The movement and the return to its rest position of the piston **18** are brought about in accordance with the invention by a rise in pressure in the second portion **14b** of the working chamber **14** by igniting an air-fuel mixture in the combustion chamber **12** (FIG. 4).

[0062] To this end the combustion chamber **12** is in direct fluidic communication with the second portion **14b**. A combustion gas outlet of the chamber **12** is connected here by a pipe **34** to an inlet of the second portion **14b**. In the example shown this inlet is situated at a forward end of the working chamber **14** at which the abutments **28** are situated.

[0063] The front end of the working chamber **14** advantageously further includes a vent **36** to the surrounding air and for possible evacuation of the combustion gases (FIG. 1).

[0064] The combustion chamber **12** may be any shape. In the example shown it has a cylindrical general shape the axis of revolution of which is substantially perpendicular to the lengthwise axis of the piston **18**. Alternatively, it could have a longitudinal orientation parallel to the piston **18**. Moreover, in the example shown it is disposed alongside the working chamber **14**. It could alternatively be disposed around the latter and be coaxial with the chamber **14**.

[0065] The pipe **34** opens into the chamber **12** in a substantially tangential direction so as to facilitate rotation of air coming from the chamber **14** in the chamber **12**.

[0066] The combustion chamber **12** may include a propeller **38** or any other means able to facilitate the mixing of air and fuel in the chamber **12** or to accentuate the phenomena of turbulence therein.

[0067] The propeller **38** may be fixed or mobile in rotation. In the latter case, the propeller **38** may be free to rotate or driven by a motor, for example an electric motor, or a turbine and also connected to the controller of the tool **10**.

[0068] Upon firing, the piston **18** moves the air contained in the second portion **14b** that is expelled from the working chamber **14** and feeds the combustion chamber **12**. This air is caused to rotate or subjected to turbulence in the chamber **12** thanks to the propeller **38** and the fuel **16** is injected into the chamber **12** to be mixed with this air. When the piston **18** reaches its FIG. 3 working position the controller of the tool is able to command the spark plug **17** to generate a spark and ignite the air-fuel mixture (FIG. 4). Ignition of the mixture generates combustion gases and a rise in pressure in the combustion chamber **12** and in the second portion **14a** of the working chamber which communicates via the pipe **34** with the chamber **12**. This pressure rise causes the piston **18** to move and to return to the rest position. The controller of the tool is then able to activate the finger **30** to return it to its position immobilizing the piston (FIG. 5). The return of the piston **18** to its rest position causes a reduced pressure in the second portion **14b** of the working chamber **14** that generates the feeding of air to this portion **14b** and the combustion chamber **12** via the vent **36**. The combustion chamber **12** advantageously also includes a vent **40** for evacuating the combustion gases and vitiated purge air (FIG. 5). The vents **36**, **40** are preferably equipped with valves controlled by the controller of the tool.

[0069] FIG. 6 shows a variant embodiment of the tool.

[0070] Here the first and second portions **14a**, **14b** of the working chamber **14** are in fluidic communication via at least one pipe **42** equipped with a valve **44** and configured



so that the air under pressure contained in the first portion **14a** and resulting from the movement of the piston **18** to its rest position is at least in part evacuated into the second portion **14b** and even into the combustion chamber **12** in order to purge that chamber **12**. The valve or valves **44** is/are controlled by the controller of the tool **10**.

**[0071]** In this variant embodiment the combustion chamber is equipped with a vent **40** and the vent **36** of the working chamber may be situated at the level of its first portion **14a**.

**[0072]** FIGS. **8** and **9** show other variant embodiments of the tool.

**[0073]** In these figures firing is brought about by pneumatic energy which here is supplied by a source **46** of non-inflammable gas under pressure, such as compressed air for example.

**[0074]** The source **46** may be disposed in the vicinity of the working chamber **14** (FIG. **8**) or remotely from the latter (FIG. **9**).

**[0075]** Moreover, in FIG. **9** the member **30** includes a pinion that cooperates with a rack (not shown) carried by or formed on the rod **18a** of the piston **18**. The controller of the tool is able to command immobilization of the pinion against rotation in order to immobilize the piston **18** in its rest position and is able to leave the pinion free to rotate to allow movement of the piston during firing and returning to the rest position.

**1-15.** (canceled)

**16.** A gas-operated fixing tool comprising:

a casing;

a working chamber in the casing;

a piston slidably mounted in the working chamber and including a driving rod having a first longitudinal end configured to drive a first fixing element and a second longitudinal end connected to a head that separates the working chamber into a first portion and into a second portion that is traversable by the driving rod; and

a combustion chamber in the casing and in fluid communication with the second portion such that a rise in pressure in the combustion chamber due to combustion of a mixture of air and fuel in the combustion chamber causes movement and return of the piston toward a rest position such that the driving rod is ready to drive a second fixing element.

**17.** The gas-operated fixing tool of claim **16**, wherein the combustion chamber is not in direct fluid communication with the first portion of the working chamber.

**18.** The gas-operated fixing tool of claim **16**, which includes an elastically deformable member elastically compressible by the piston during movement of the piston to the rest position and elastically expandable to cause the piston to move from the rest position to drive the first fixing element.

**19.** The gas-operated fixing tool of claim **16**, wherein the first portion is in fluid communication with a pressurized non-flammable gas source to cause the piston to move from the rest position to drive the first fixing element.

**20.** The gas-operated fixing tool of claim **16**, which includes a piston movement blocking element engageable with the piston in the rest position.

**21.** The gas-operated fixing tool of claim **16**, which includes an elastic damping stop in the second portion and engageable by the piston after moving from the rest position.

**22.** The gas-operated fixing tool of claim **16**, which includes a propeller in the combustion chamber.

**23.** The gas-operated fixing tool of claim **22**, wherein the propeller is free to rotate or configured to be driven in rotation by a motor.

**24.** The gas-operated fixing tool of claim **16**, which includes a spark plug partially in the combustion chamber and wherein the combustion chamber is fluidly connectable to a replaceable fuel cartridge supported by the casing.

**25.** The gas-operated fixing tool of claim **16**, wherein one of the second portion and the combustion chamber include a vent configured to vent discharge combustion gases.

**26.** The gas-operated fixing tool of claim **16**, wherein the first portion and the second portion are in fluid communication via at least one duct having a valve and configured such that the pressurized air contained in the first portion resulting from movement of the piston to the rest position is at least partially dischargeable into the second portion or into the combustion chamber.

**27.** A gas-operated fixing tool comprising:

a casing;

a working chamber in the casing;

a piston slidably mounted in the working chamber and including a driving rod having a first longitudinal end configured to drive a first fixing element and a second longitudinal end connected to a head that separates the working chamber into a first portion and into a second portion that is traversable by the driving rod;

a combustion chamber in the casing and in fluid communication with the second portion such that a rise in pressure in the combustion chamber due to combustion of a mixture of air and fuel in the combustion chamber causes movement and return of the piston toward a rest position such that the driving rod is ready to drive a second fixing element, and wherein the combustion chamber is not in direct fluid communication with the first portion of the working chamber; and

a piston movement blocking element engageable with the piston in the rest position.

**28.** The gas-operated fixing tool of claim **27**, which includes an elastically deformable member elastically compressible by the piston during movement of the piston to the rest position and elastically expandable to cause the piston to move from the rest position to drive the first fixing element.

**29.** The gas-operated fixing tool of claim **27**, wherein the first portion is in fluid communication with a pressurized non-flammable gas source to cause the piston to move from the rest position to drive the first fixing element.

**30.** The gas-operated fixing tool of claim **16**, which includes a spark plug partially in the combustion chamber and wherein the combustion chamber is fluidly connectable to a replaceable fuel cartridge supportable by the casing.

**31.** A method of operating a gas-operated fixing tool having a working chamber and a piston including a driving rod having a first longitudinal end and a second longitudinal end connected to a head that separates the working chamber into a first portion and into a second portion, said method comprising:

moving the piston in the working chamber from a rest position to a driving position to drive a first fixing element; and

combusting a mixture of air and fuel in a combustion chamber and fluidly communicating a rise in pressure caused by the combustion to the second portion to

cause movement and return of the piston toward the rest position such that the driving rod is ready to drive a second fixing element.

**32.** The method of operating a gas-operated fixing tool of claim **31**, which includes causing a blocking element to release the piston to enable moving the piston in the working chamber.

**33.** The method of operating a gas-operated fixing tool of claim **31**, which includes elastically expanding an elastically deformable member to cause the moving of the piston from the rest position to the driving position to drive the first fixing element.

**34.** The method of operating a gas-operated fixing tool of claim **31**, wherein moving the piston in the working chamber from the rest position to the driving position includes supplying the first portion of the working chamber with a pressurized and non-flammable gas.

**35.** The method of operating a gas-operated fixing tool of claim **31**, which includes fluidly communicating gases expelled from the second portion of the chamber due to moving the piston in the working chamber from the rest position to the driving position into the combustion chamber to create turbulence in the combustion chamber.

\* \* \* \* \*