



(19) **United States**

(12) **Patent Application Publication**
SAID et al.

(10) **Pub. No.: US 2015/0285542 A1**

(43) **Pub. Date: Oct. 8, 2015**

(54) **INTERMITTENT ABSORPTION SYSTEM WITH A LIQUID-LIQUID HEAT EXCHANGER**

(52) **U.S. Cl.**
CPC *F25B 27/007* (2013.01); *F25B 17/02* (2013.01)

(71) Applicant: **KING FAHD UNIVERSITY OF PETROLEUM AND MINERALS**, Dhahran (SA)

(57) **ABSTRACT**

(72) Inventors: **SYED A.M. SAID**, DHAHRAN (SA); **MUHAMMAD UMAR SIDDIQUI**, DHAHRAN (SA)

The intermittent absorption system with a liquid-liquid heat exchanger includes two generator/absorber units that operate out-of-phase, a solar collector unit, a dephlegmator, a condenser unit, an evaporator, and valves to control the flow of aqua-ammonia coolant through the system. The system operates on a two-day cycle. On the first day, during the daytime, the first generator/absorber unit generates liquid ammonia, while on the second day of the cycle, the roles are reversed, the second generator/absorber unit generating liquid ammonia. At the start of each day, one generator/absorber unit is partially pressurized and the other partially depressurized by liquid-liquid heat exchange between their heat exchangers, followed by disconnecting the heat exchangers from each other and connecting the generator to the solar collector to complete pressurization. The liquid-liquid heat exchange between the generator/absorber units reduces the heat required from the solar collector to generate liquid ammonia refrigerant, improving the coefficient of performance.

(73) Assignee: **KING FAHD UNIVERSITY OF PETROLEUM AND MINERALS**, Dhahran (SA)

(21) Appl. No.: **14/243,727**

(22) Filed: **Apr. 2, 2014**

Publication Classification

(51) **Int. Cl.**
F25B 27/00 (2006.01)
F25B 17/02 (2006.01)

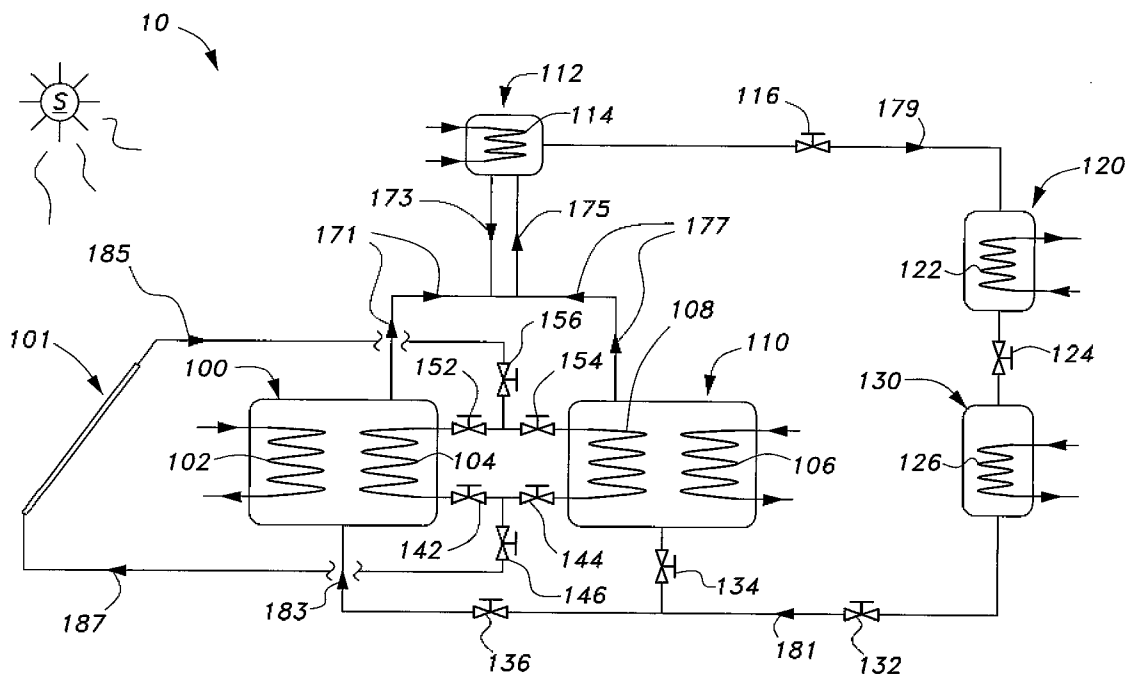

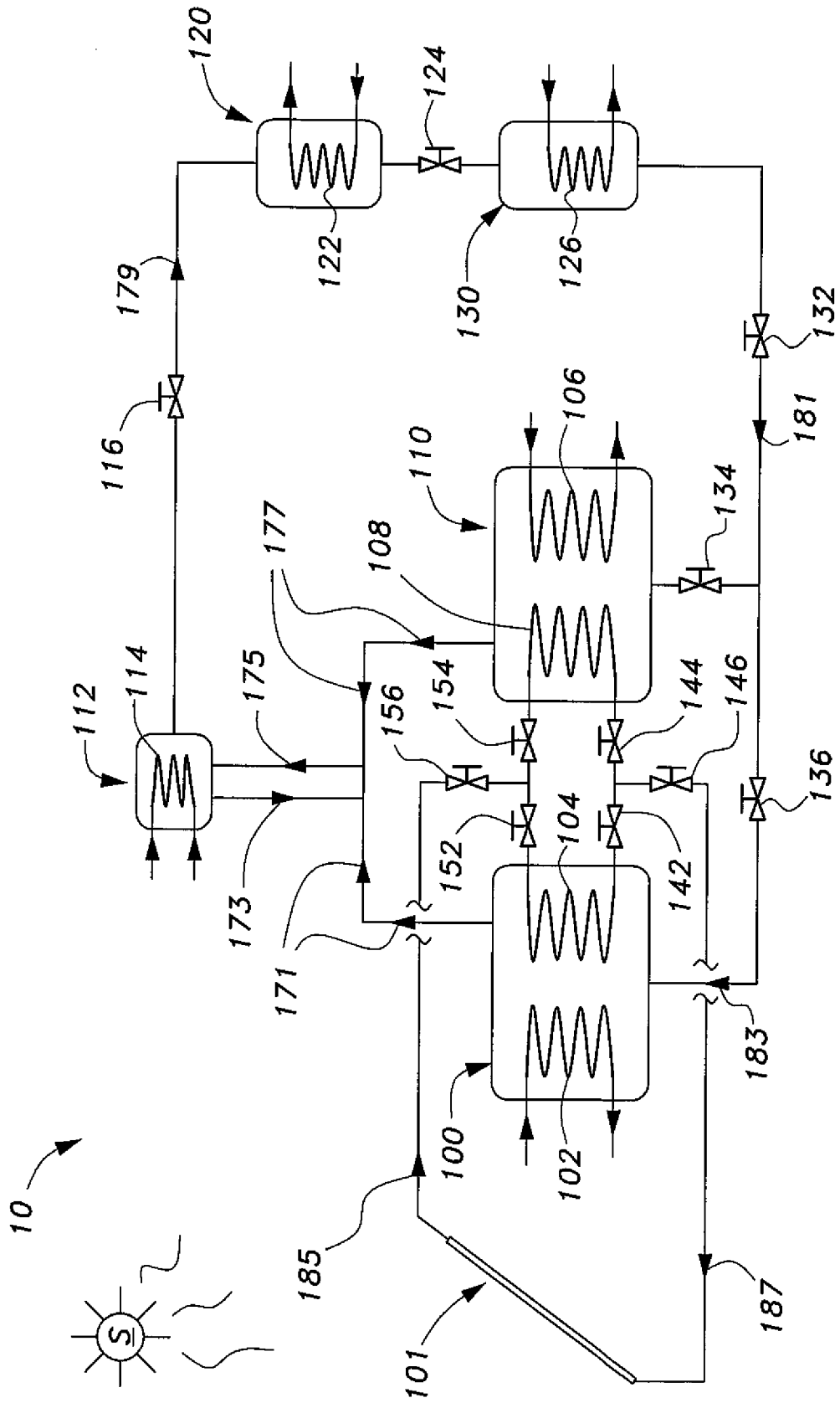

INTERMITTENT ABSORPTION SYSTEM WITH A LIQUID-LIQUID HEAT EXCHANGER

BACKGROUND OF THE INVENTION

[0001] 1. Field of the Invention

[0002] The present invention relates to cooling and refrigeration systems, and more particularly to an intermittent absorption system with a liquid-liquid heat exchanger that uses waste heat to reduce the need for solar energy and increase the coefficients of performance of intermittent absorption air-conditioning and refrigeration systems.

[0003] 2. Description of the Related Art

[0004] Conservation of energy, namely electricity, in both the production and consumption sectors, is continuing to be a worldwide priority. One such area is in the development of air-conditioning and refrigeration systems. It is no surprise that the days, times, and locations requiring maximum cooling loads coincide with the days and times with the highest temperatures and locations with the hottest climates. Conventional air-conditioning and refrigeration systems are powered using electricity. In the areas with the hottest climates and during the days and times with the hottest temperatures, the use of electricity to power such air-conditioning and refrigeration systems becomes very expensive and inefficient.

[0005] Solar power can be utilized to provide power for refrigeration and air-conditioning systems. Absorption chillers, for example, can use solar energy to produce refrigeration. Absorption chillers can be classified in two different categories, namely, continuous operation systems and intermittent operation systems. The difference between the two systems lies in their mode of operation. For example, in continuous systems both generation and absorption of energy take place at the same time in a continuous manner, whereas in intermittent systems, the generation and absorption of energy do not take place at the same time. Instead the generation and absorption of energy follow each other intermittently within the operation of the system.

[0006] Compared to continuous systems, intermittent systems have an advantage of not requiring any solution pump for their operation. Although not requiring a solution pump, their coefficient of performance is still comparatively very low. The main reason for higher coefficient of performance of continuous systems is their ability to recover waste energy by employing a liquid-liquid heat exchanger. The ability to recover waste heat in continuous operation systems is due to the fact that both absorption and generation take place at the same time so that both hot and cold solutions are present during the operation at the same time, hence making it possible to recover waste energy.

[0007] However, for conventional intermittent systems, it is not usually possible to use a liquid-liquid heat exchanger simultaneously for waste energy recovery due to the unavailability of hot and cold solutions at the same time. The inability of conventional intermittent systems to use a liquid-liquid heat exchanger simultaneously to recover waste energy results in a significant increase in capital cost and a decrease in its coefficient of performance, therefore, making conventional intermittent absorptions systems cost prohibitive and not economically feasible.

[0008] Thus, an intermittent absorption system with a liquid-liquid heat exchanger solving the aforementioned problems is desired.

SUMMARY OF THE INVENTION

[0009] The intermittent absorption system with a liquid-liquid heat exchanger includes two generator/absorber units that operate out-of-phase, a solar collector unit, a dephlegmator, a condenser unit, an evaporator, and valves to control the flow of aqua-ammonia coolant through the system. The system operates on a two-day cycle. On the first day, during the daytime, the first generator/absorber unit is pressurized to generate liquid ammonia, which is stored in the evaporator, while the second generator/absorber unit is depressurized by heat exchange with ambient air. At nighttime, liquid ammonia is evaporated to produce refrigerant effect, and the second generator/absorber unit acts as an absorber. On the second day of the cycle, the roles are reversed, the second generator/absorber unit generating liquid ammonia in the daytime and the first generator/absorber unit acting as an absorber. At the start of each day, one generator/absorber unit is partially pressurized and the other partially depressurized by liquid-liquid heat exchange between their heat exchangers, followed by disconnecting the heat exchangers from each other and connecting the generator to the solar collector to complete pressurization.

[0010] In this manner, part of the energy required to generate the aqua-ammonia vapor that is converted to liquid ammonia is derived from liquid-liquid heat exchange between hot and cold liquids simultaneously present in the system, which is heat energy that would otherwise be wasted. The balance of the energy required to generate the aqua-ammonia vapor is derived from the solar collector unit. However, the quantity of heat that must be derived from the solar collector is decreased by the liquid-liquid heat exchange, reducing the installation costs of the solar collector unit and improving the coefficient of performance of the intermittent absorption system in an energy efficient manner.

[0011] These and other features of the present invention will become readily apparent upon further review of the following specification and drawings.

BRIEF DESCRIPTION OF THE DRAWINGS

[0012] The sole drawing FIGURE is a schematic diagram of an intermittent absorption system with a liquid-liquid heat exchanger according to the present invention.

DETAILED DESCRIPTION OF THE PREFERRED EMBODIMENTS

[0013] Referring to the sole drawing FIGURE, the intermittent absorption system with a liquid-liquid heat exchanger, designated generally as **10** in the drawing, includes two generator/absorber units that operate out-of-phase. The intermittent absorption system **10** includes a first generator/absorber unit **100**, a second generator/absorber unit **110**, a dephlegmator unit **112**, a condenser unit **120**, an evaporator unit **130**, and a solar collector unit **101** that uses electrical power derived from the sun to heat aqua-ammonia coolant that circulates throughout the system **10**.

[0014] The first generator/absorber unit **100** houses a first heat exchanger **104** for heating purposes when the first generator/absorber unit **100** is operated as a generator, and a second heat exchanger **102** for cooling purposes when the first generator/absorber unit **100** is operated as an absorber. The second generator/absorber unit **110** also houses a first heat exchanger **108** for heating purposes when the second generator/absorber unit **110** is operated as a generator, and a

second heat exchanger **106** for cooling purposes when the second generator/absorber unit **110** is operated as an absorber. As in conventional intermittent absorption chillers, the generator/absorber units typically operate as a generator in the daytime and as an absorber at nighttime.

[0015] The solar collector **101** is in communication with the first and second generator/absorber units **100**, **110** by conduits controlled by valves **146** and **156**. Valve **146** is located in the stem of a T-connection that includes valves **142** and **144**, which connect one end of heat exchangers **104** and **108**. Valve **156** is located in the stem of a T-connection that includes valves **152** and **154**, which connect the opposite end of heat exchangers **104** and **108**. When valves **146** and **156** are closed, valves **142**, **144**, **152**, and **154** may be opened for liquid-liquid heat exchange between the generator heat exchanger **104** of the first generator/absorber unit **100** and the generator heat exchanger **108** of the second generator/absorber unit **110**. When valves **146** and **156** are open, valves **142** and **152** may be open and valves **144**, **154** closed to connect the solar collector **101** to the first generator/absorber unit **100**, or valves **142** and **152** may be closed and valves **144**, **154** open to connect the solar collector **101** to the second generator/absorber unit **110**.

[0016] The first generator/absorber unit **100** and the second generator/absorber unit **110** are in communication with the dephlegmator unit **112**. The dephlegmator unit **112** is located above both generator/absorber units **100**, **110**. The dephlegmator unit **112** houses a heat exchanger **114** and essentially acts as a reflux condenser that receives aqua-ammonia vapor from one of the generator/absorber units **100**, **110** and passes ammonia vapor on to the condenser unit **120**, while condensing water and returning the water to the corresponding generator/absorber unit **100**, **110**, thereby rectifying the aqua-ammonia vapor.

[0017] The dephlegmator unit **112** is in communication with the at least one condenser unit **120** through a conduit controlled by a ball valve **116**. The condenser unit **120** houses a heat exchanger **122** for converting the ammonia vapor to liquid ammonia, and is in communication with the evaporator unit **130** through conduit controlled by a valve **124**. The liquid ammonia produced by the condenser unit **120** is stored in the evaporator unit **130** in the daytime.

[0018] The evaporator unit **130** houses a heat exchanger **126**. At nighttime, the pressure in the evaporator unit is decreased so that the ammonia is converted to vapor, producing a refrigeration effect in the heat exchanger **126**. The evaporator unit **130** is in communication with one or the other of the generator/absorber units **100**, **110** through conduit controlled by a throttling valve **132**. It should be understood that the valves used in the intermittent absorption system with a liquid-liquid heat exchanger **10** are not limited to ball valves and throttling valves, but can also include valves such as check valves, gate valves, globe valves, and butterfly valves, for example. When valves **132** and **134** are open and valve **136** is closed, the evaporator unit **130** is connected to the second generator/absorber unit **110** so that the ammonia vapor is absorbed by the second generator/absorber unit **110**. When valves **132** and **136** are open and valve **134** is closed, the evaporator unit **130** is connected to the first generator/absorber unit **100** so that the ammonia vapor is absorbed by the first generator/absorber unit **100**.

[0019] Due to the intermittent nature of the system **10**, each of the two generator/absorber units **100** and **110** behaves as a generator during the day and behaves as an absorber during

the night. The system **10** operates on a 48-hour cycle. The process begins with a partial pressurization of a strong aqua-ammonia solution in the first generator/absorber unit **100** and a partial depressurization of a weak aqua-ammonia solution in the second generator/absorber unit **110** during the daytime of the first day of the 48-hour cycle.

[0020] The partial pressurization and depressurization processes are commenced by the heat transfer between the cold, strong aqua-ammonia solution of the first generator/absorber unit **100** and the hot, weak aqua-ammonia solution of the second generator/absorber unit **110** by connecting heat exchangers **104** and **108** for liquid-liquid heat exchange. During the partial pressurization/partial depressurization processes, the solar collector **101** is kept isolated from the generator/absorber units **100**, **110** by closing valves **156** and **146**. While valves **156** and **146** are closed, valves **152**, **154**, **142**, and **144** are opened to allow the liquid-liquid heat exchange to occur between the first generator/absorber unit **100** and the second heat generator/absorber unit **110**. The flow required for this heat exchange to take place is provided by a thermosiphon effect between the heat exchangers **104**, **108**.

[0021] The water in heat exchange coil **108** of the second generator/absorber **110** gains the heat from the hot weak aqua-ammonia solution in the second generator/absorber unit **100** and becomes less dense. The water in the heat exchange coil **108** of the second generator/absorber **110** is then transferred to the heat exchange coil **104** in the first generator/absorber **100**. As the water from the second generator/absorber unit **110** is absorbed into the heat exchange coil **104** it loses heat to the cold strong aqua-ammonia solution in the first generator/absorber unit **100**. The coolant (which may be water) within the heat exchanger **108** gains heat from the hot, weak aqua-ammonia solution, becomes less dense, and rises to enter heat exchanger **104**, where it loses heat to the comparatively cold, weak aqua-ammonia solution within the first generator/absorber unit **100**.

[0022] As a result, the temperature of the cold, strong aqua-ammonia solution in the first generator/absorber unit **100** will rise, while the temperature of the hot, weak aqua-ammonia solution in the second generator/absorber unit **110** will decrease. Ideally, the temperature of the cold, weak aqua-ammonia solution in the first generator/absorber unit would rise to equilibrium, where it would be equal to the temperature of the hot, weak aqua-ammonia solution in the second generator/absorber unit **110**. However, practically, heat exchange will continue until a temperature difference of ΔT_{min} is maintained between the cold, strong aqua-ammonia solution in the first generator/absorber unit **100** and the hot weak aqua-ammonia solution in the second generator/absorber unit **110**, such that temperature of the weak aqua-ammonia solution in the second generator/absorber unit **110** is higher than the strong aqua-ammonia solution in the first generator/absorber unit **100**. During this process, partial cooling of weak aqua-ammonia solution in the second generator/absorber unit **110** occurs and partial heating of strong aqua-ammonia solution in the first generator/absorber unit **100** also occurs.

[0023] Once the temperature difference of ΔT_{min} is maintained between the cold strong aqua-ammonia solution in the first generator/absorber unit and the hot weak aqua-ammonia solution in the second generator/absorber unit, the second generator/absorber **110** is disconnected from the first generator/unit **100** and the first generator/absorber unit **100** is con-

nected to the solar collector **101**. This can be accomplished by closing valves **144**, **154** and opening valves **146**, **156**.

[0024] The pressurization of the first generator/absorber unit **100** continues beyond the partial pressurization of two connected generator/absorber units by heat transfer **185** from the sun **S** through the solar collector **101** during daytime of the first day of the 48-hour cycle. During first 24 hours within a 48-hour cycle, the first generator/absorber unit **100** operates as a generator as heat is added to the system through the heat exchanger **104** from the solar collector **101** at constant pressure.

[0025] As a result of the heat transfer **185** from the solar collector **101**, the temperature of the strong aqua-ammonia solution in the first generator/absorber unit **100** rises. As a result of the generation process and the heat gained through the solar collector **101**, aqua-ammonia vapor forms in the first generator/absorber unit **100** and the concentration of the strong aqua-ammonia solution drops, which also further increases the temperature of the solution.

[0026] The first heat exchange coil **104** continues the generation process and the water content inside of the generated aqua-ammonia vapor increases as the temperature in the first generator/absorber unit **100**. Meanwhile, depressurization of the weak aqua-ammonia solution in the second generator/absorber **110** also occurs, as the heat exchanger **106** rejects the heat to ambient air. This decrease in temperature is accompanied by a decrease in pressure as depressurization continues throughout the daytime of the first day of the 48-hour cycle.

[0027] During the daytime of the first day, the valve **172** is open and the valve **174** is closed so that the aqua-ammonia vapor generated in the first generator/absorber unit **100** rises to the dephlegmator unit **112** via conduit paths **171**, **175**. In the dephlegmator **112**, water condenses from the aqua-ammonia vapor (being cooled by heat exchanger **114**) and returns to the first generator/absorber unit **100** via conduit path **173**, **171**. The pure or rectified ammonia vapor continues to the condenser unit **120** via conduit path **179** as regulated by valve **116**. The rectified or purified ammonia vapor is condensed by rejecting the heat to the heat exchanger **122**, then passed through valve **124** and is stored as saturated liquid ammonia inside of the evaporator **130** during the day of the first day of the 48-hour cycle.

[0028] The process continues during the nighttime of the first day of the 48-hour cycle, when the second generator/absorber unit **110** operates as an absorber for the intermittent system **10**. At this point, the throttling valve **132** is opened, which reduces the pressure inside of the evaporator unit **130** so that the ammonia vaporizes, producing a refrigeration effect in the heat exchanger **126** as a result of the evaporation of the refrigerant. The heat exchanger **126** inside of the evaporator unit **130** can be filled with a brine solution to avoid the heat exchanger **126** becoming inoperative if the refrigerant effect is below the freezing point of water. The ammonia refrigerant vapor is then moved from the evaporator unit **130** through the throttling valve **132** and directed by conduit path **181** through the ball valve **134** to the second generator/absorber unit **110** for absorption of the ammonia vapor into the weak aqua-ammonia solution inside the unit **110**.

[0029] The valve **136** is closed through this nighttime phase of the first day of the 48-hour cycle to in order keep the first generator/absorber unit **100** isolated from the absorption process. In keeping the first generator/absorber unit **100** isolated, a strong aqua-ammonia solution is produced inside the sec-

ond generator/absorber unit **110** so the heat is not absorbed by the heat exchanger **106** during the nighttime phase of the first day of the 48-hour cycle. A coolant is provided to the heat exchange coil **106** in the second generator/absorber unit **110**, the condenser unit **120**, and the dephlegmator unit **112** during day of the first day of the 48-hour cycle and to the heat exchange coil **106** during the night of the first day of the 48-hour cycle.

[0030] At the start of the first day of the 48-hour cycle, the first generator/absorber unit **100** was initially filled with cold strong aqua-ammonia solution and the second generator/absorber unit **110** was initially filled with hot weak aqua-ammonia solution. After the operations during the first 24, the first generator/absorber unit **100** contains hot, weak aqua-ammonia solution and the second generator/absorber unit **110** contains cold, strong aqua-ammonia solution.

[0031] Continuing the process into the second day of the 48-hour cycle, the intermittent absorption system reverses its method of operation. The second day of the 48-hour cycle begins with the partial pressurization of the second generator/absorber unit **110** instead of the first generator/absorber unit **100**, and the partial depressurization of the first generator/absorber unit **100**. The partial pressurization/partial depressurization process begins by closing valves **146** and **156** to isolate the solar collector **101** from the generator/absorber units **100**, **110** and opening valves **142**, **152**, **144**, and **154** to connect heat exchangers **104** and **108** for liquid-liquid heat exchange, as described above. During this process, the strong, cold aqua-ammonia solution in the second generator/absorber unit is partially heated, and the weak, hot aqua-ammonia solution in the first generator/absorber unit is partially cooled.

[0032] Once the partial pressurization of the second generator/absorber unit **110** and depressurization of the first generator/absorber unit **100** is complete, the first generator/absorber unit **100** is disconnected from the second generator/absorber unit **110**. Valves **142** and **152** are closed and valves **146**, **156** are opened, thereby connecting the solar collector **101** to the generator heat exchanger **108** of the second generator/absorber unit **110**. At the same time, heat exchanger **102** cools the weak aqua-ammonia solution in the first generator/absorber unit **100**, thereby continuing depressurization during the daytime of the second day of the 48-hour cycle.

[0033] The pressurization continues to occur within the second generator/absorber unit **110** by gaining heat from the solar collector **101**. The pressurization in the second generator/absorber unit **110** is followed by the processes of generation of aqua-ammonia vapor, dephlegmation, and condensation of liquid ammonia in a similar manner as that described during daytime of the first day of the 48-hour cycle. The aqua-ammonia vapor rises to the dephlegmator **112** via conduit path **177**, **175**, while keeping the valve **174** open and the valve **172** closed, and the condensed water returns to the second generator/absorber unit via conduit path **173**, **177**. Rectified ammonia vapor travels from the dephlegmator **112** to the condenser via conduit **179**, regulated by valve **116**, is condensed to saturated liquid ammonia refrigerant in condenser **120**, and is stored in the daytime of the second day in the evaporator unit **130**.

[0034] The process continues during the night of the second day of the 48-hour cycle, where the first generator/absorber unit **100** operates as an absorber for the intermittent system **10**. At this point the throttling valve **132** is opened, which reduces the pressure inside of the evaporator unit **130** and

produces a refrigeration effect in the heat exchange coil 126 as a result of the evaporation of the refrigerant. The heat exchange coil 126 inside of the evaporator unit 130 may be filled with a brine solution to avoid the heat exchange coil 126 becoming inoperative if the refrigerant effect is below the freezing point of water. The ammonia refrigerant vapor is then moved from the evaporator unit 130 through the throttling valve 132 and directed by conduit path 181 through the ball valve 136 to the first generator/absorber 100 for absorption of the ammonia into the weak aqua-ammonia solution inside. Valve 134 is closed during this process.

[0035] In keeping the second generator/absorber unit 110 isolated, a strong aqua-ammonia solution is produced inside the first generator/absorber unit 100, as the heat is not absorbed by the heat exchanger 102 during the nighttime phase of the second day of the 48-hour cycle. A coolant is provided to the heat exchange coil 102 in the first generator/absorber unit 100, the condenser unit 120, and the dephlegmator unit 112 during daytime of the second day of the 48-hour cycle and to the heat exchange coil 102 during the nighttime of the second 24 hours in a 48-hour cycle.

[0036] At the beginning of the second 24 hours of the 48-hour cycle, the second generator/absorber unit 110 was filled with cold, strong aqua-ammonia solution and the first generator/absorber unit 100 was filled with hot, weak aqua-ammonia solution. After the operations during the second day of the 48-hour cycle, the second generator/absorber unit 110 contains hot, weak aqua-ammonia solution and the first generator/absorber unit 100 contains cold, strong aqua-ammonia solution.

[0037] This 48-hour cycle then repeats itself indefinitely to maintain the intermittent absorption system for as long as desired. The system 10 thus uses liquid-liquid heat exchange during the pressurization/depressurization stages at the start of each day to recapture heat that would otherwise be wasted to ambient air through the absorber heat exchangers 102, 106 to reduce the energy demands on the solar collector unit 101, thereby permitting a smaller, low-cost solar collector installation and improving the coefficient of performance of the system 10.

[0038] The intermittent absorption system 10 may include a conventional control system to control the timing of opening and closing the various valves, which may be solenoid valves or servo motor-controlled valves, in the system 10. The control system may include a processor, such as a programmable logic controller, a timer circuit, and various sensors, including photodetectors, temperature sensors, pressure sensors, etc., as is known in the art.

[0039] It is to be understood that the present invention is not limited to the embodiments described above, but encompasses any and all embodiments within the scope of the following claims.

I claim:

- 1. An intermittent absorption system with a liquid-liquid heat exchanger, comprising:
 - a first combination generator/absorber unit and a second combination generator/absorber unit, each of the combination generator absorption units having a generator heat exchanger and an absorber heat exchanger;
 - a dephlegmator;
 - a condenser;
 - an evaporator;
 - a solar collector unit;

- a conduit system connecting the combination generator/absorber units, the dephlegmator, the condenser, the evaporator, and the solar collector unit;
- a plurality of valves disposed in the conduit system for controlling coolant flow, the conduit system and the valves being configured so that:
 - the solar collector panel is selectively connected by the conduit system to the generator heat exchanger of the first combination generator/absorber unit, the generator heat exchanger of the second combination generator/absorber unit, or neither of the combination generator/absorber units; and
 - the generator heat exchanger of the first combination generator/absorber unit and the generator heat exchanger of the second combination generator/absorber unit are selectively connected to each other for liquid-liquid heat exchange between the combination generator/absorber units; and
- an aqua-ammonia coolant circulating in the conduit system, the coolant including ammonia refrigerant and water absorber.
- 2. A method for intermittent absorption chilling and refrigeration in a 48-hour duty cycle, comprising the steps of:
 - disconnecting a solar collection unit from a first combination generator/absorber unit and a second combination generator/absorber unit;
 - connecting a generator heat exchanger of the first combination generator/absorber unit to a generator heat exchanger of the second combination generator/absorber unit for liquid-liquid heat exchange to partially pressurize the first combination generator/absorber unit and partially depressurize the second combination generator/absorber unit;
 - after partial pressurization and depressurization of the combination generator/absorber units, connecting the solar collection unit to the first combination generator/absorber unit to pressurize the first combination generator/absorber unit while depressurizing the second combination generator/absorber unit;
 - storing liquid ammonia generated by the first combination generator/absorber unit in an evaporator during daytime of the first day of the 48-hour duty cycle;
 - evaporating the liquid ammonia during the nighttime of the first day of the 48-hour duty cycle to produce a refrigerant effect in the evaporator;
 - directing flow of the evaporated ammonia to the second combination generator/absorber unit for absorption during nighttime of the first day of the 48-hour duty cycle;
 - thereafter, disconnecting the solar collection unit from the first combination generator/absorber unit and the second combination generator/absorber unit;
 - thereafter, connecting the generator heat exchanger of the first combination generator/absorber unit to the generator heat exchanger of the second combination generator/absorber unit for liquid-liquid heat exchange to partially pressurize the second combination generator/absorber unit and partially depressurize the first combination generator/absorber unit;
 - after partial pressurization and depressurization of the combination generator/absorber units, connecting the solar collection unit to the second combination generator/absorber unit to pressurize the second combination generator/absorber unit while depressurizing the first

combination generator/absorber unit during daytime of the second day of the 48-hour duty cycle;
storing liquid ammonia generated by the second combination generator/absorber unit in an evaporator during daytime of the second day of the 48-hour duty cycle;
evaporating the liquid ammonia during the nighttime of the second day of the 48-hour duty cycle to produce a refrigerant effect in the evaporator; and
directing flow of the evaporated ammonia to the first combination generator/absorber unit for absorption during nighttime of the second day of the 48-hour duty cycle.

* * * * *