

No. 785,702.

PATENTED MAR. 28, 1905.

A. O. ARNOLD.

FREIGHT CAR DOOR FASTENER.

APPLICATION FILED DEC. 19, 1901. RENEWED FEB. 12, 1903.

2 SHEETS—SHEET 1.

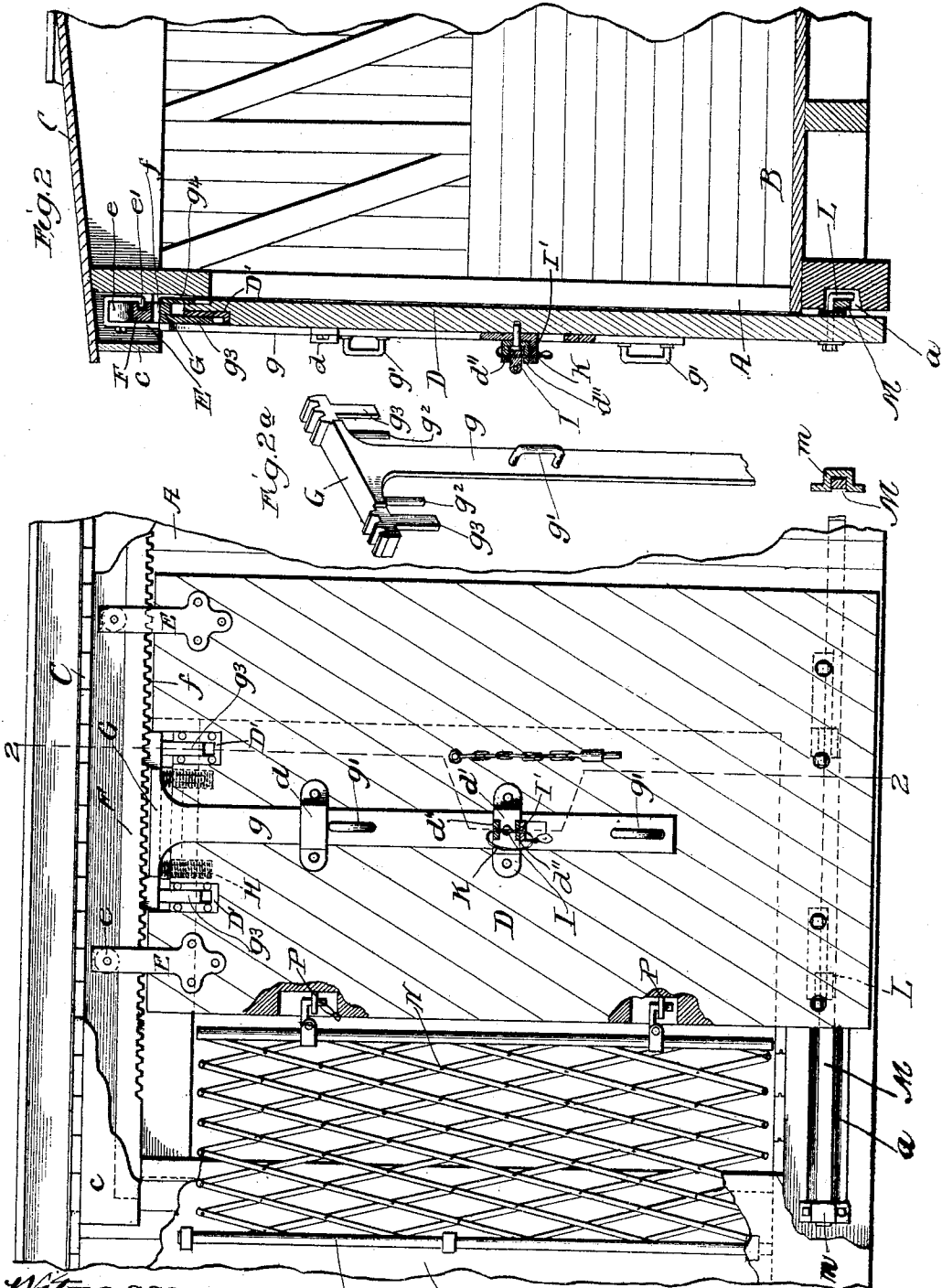

Witnesses:

Harold E. Bault
Bell & Evans.

Fig. 1

A. O. Arnold Inventor.

By W. Hopkins Atty.

A. O. ARNOLD.

FREIGHT CAR DOOR FASTENER.

APPLICATION FILED DEC. 19, 1901. RENEWED FEB. 12, 1903.

2 SHEETS—SHEET 2.

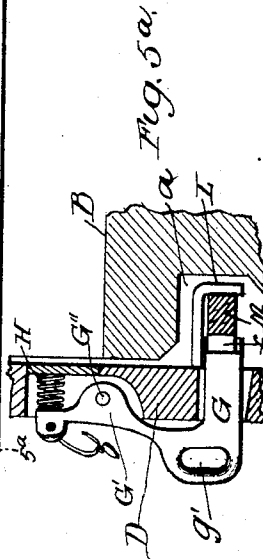
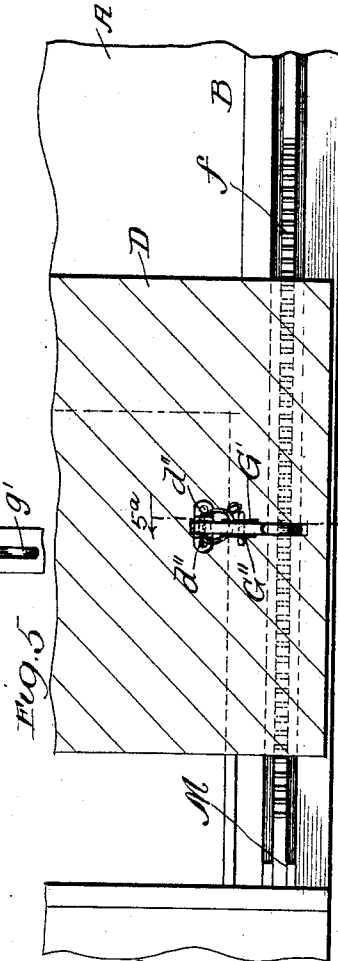
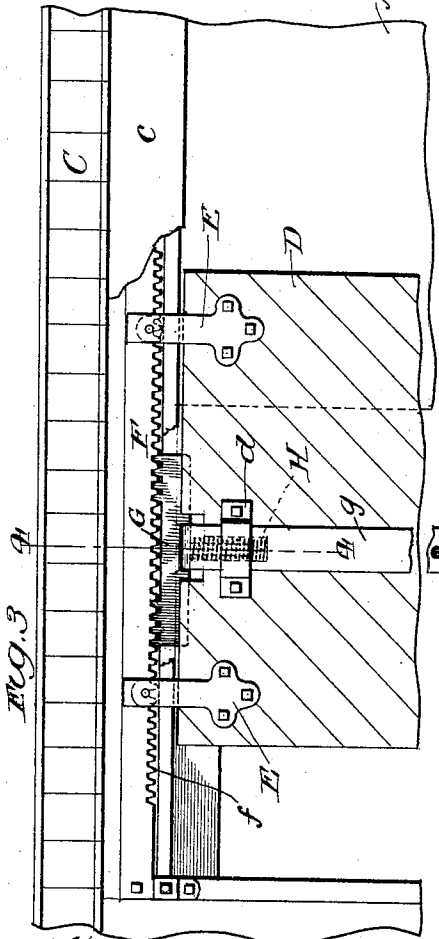
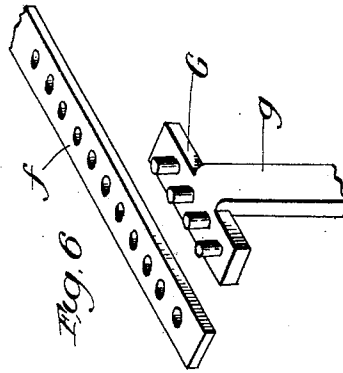
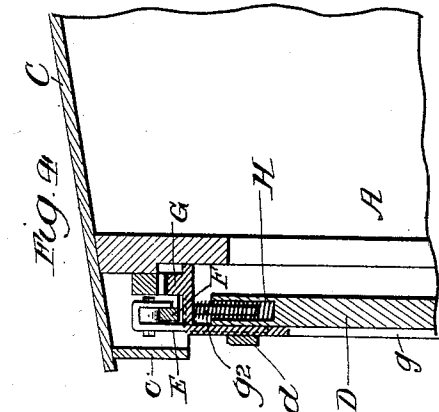

Witnesses:

Harold E. Barrett
Bella Evans.

Andrew O. Arnold, Inventor.

By *[Signature]*
Atty.

UNITED STATES PATENT OFFICE.

ANDREW O. ARNOLD, OF GALESBURG, ILLINOIS.

FREIGHT-CAR-DOOR FASTENER.

SPECIFICATION forming part of Letters Patent No. 785,702, dated March 28, 1905.

Application filed December 19, 1901. Renewed February 12, 1903. Serial No. 143,089.

To all whom it may concern:

Be it known that I, ANDREW O. ARNOLD, a citizen of the United States, residing at Galesburg, in the county of Knox and State of Illinois, have invented certain new and useful Improvements in Freight-Car-Door Fasteners, of which the following is a specification.

The object of the present invention is to provide simple and effective means whereby the door of a freight-car may be locked or sealed, or both locked and sealed either in its closed position or in any intermediate position between its closed and completely open position.

Frequently the character of the freight with which the car is loaded makes it desirable to leave the door partly open for the purpose of ventilation, while at the same time it is desirable to lock or seal or both lock and seal it, so that it cannot be opened farther. For instance, in the shipment of horses and other live stock or poultry in box-cars it is desirable to leave the door partly open for the purposes of ventilation and permitting ingress and egress of the attendant, while it is not desirable that the door be left free to be completely opened at the will of whosoever will. Again, in the shipment of vegetables, fruits, and other perishable freight, which is not usually accompanied by an attendant, it is desirable to leave the door partly open and at the same time prevent the ingress or egress of any person.

The object of the present invention is to provide improved means whereby these desiderata may be attained; and to this end the invention consists in the features of novelty that are hereinafter described.

In the accompanying drawings, which are made a part of this specification, Figure 1 is a side elevation of a portion of a freight-car having a door-fastener embodying the invention in its preferred form, portions of the framing of the car being broken away. Fig. 2 is a vertical transverse section thereof on the line 2 2, Fig. 1. Fig. 2^a is a perspective view of the detent and its pull-rod. Fig. 3 is a side elevation of a portion of a car and of a door-fastener embodying some features of the invention under a modification. Fig. 4 is a

vertical transverse section thereof on the line 4 4, Fig. 3. Fig. 5 is a side elevation of a portion of a car and a door-fastener embodying some features of the invention under still another modification. Fig. 5^a is an enlarged vertical section on the line 5^a, Fig. 3, looking in the direction of the arrows. Fig. 6 is a perspective view of some of the parts under still another modification.

In all of the several modifications like parts are designated by like letters of reference.

A represents the side, B the floor, C the roof, and D the door, of a freight-car, all of which may be of customary or of any desired construction.

In the preferred form of the invention the door is supported by hangers E, having rollers *e*, which bear upon the top side of a rail F, the ends of which are secured to the side of the car behind the eave-board *e*, so as to leave a space between said rail and the side of the car. Into this space project downturned portions of the hangers E, and these downturned portions terminate in flanges or fingers *e'*; which project into a groove in the rear side of the rail F, whereby the door is prevented from being either lifted or moved outward away from the side of the car. On the under side of the rail is a toothed rack *f*, which is engaged by a detent G, carried by the door. In the preferred form of the invention this detent consists of a rack-bar considerably shorter than the rack *f*. It has a pull-rod *g*, slidably mounted in bearings *d d'*, carried by the car-door, and this pull-rod is provided with one or more handles *g'*, by which it may be moved endwise when free so to do. The detent is held normally in engagement with the rack *f* by means of a coiled spring or springs H, mounted in a suitable socket or sockets in the door, and for confining and guiding the springs or each of them the detent is provided with a pin or stud *g''*, which projects into it.

For the purpose of preventing the outward movement of the detent away from the side of the car it is provided with a flange or projection *g^t*, which extends downward past the top of the door and engages the back of it, the door being preferably recessed to receive it.

For the purpose of sustaining and bracing the

detent in the direction of its length and relieving the pull-rod g and the brackets or guides d d' of injurious strain the detent is provided with tongues or fingers g^2 , which occupy
5 grooves in castings D' , let into recesses in the face of the door and secured thereto by any suitable means.

With the parts constructed and arranged as above described the spring or springs H will
10 hold the detent normally in engagement with the rack f and prevent the door from being moved in either direction. When the detent is disengaged from the rack, which may be done by grasping one or both of the handles
15 g' and exerting a downward pull upon the rod g of the detent, the door may be moved in either direction, and when the rod g is again released the spring or springs H will again cause the detent to engage the rack. When
20 the door has been placed in the desired position, whether closed or partially open, it may be locked or sealed or both locked and sealed by locking or sealing or both locking and sealing the detent. This is preferably done
25 through the medium of its pull-rod g .

In Figs. 1 and 2 I have shown the guide d' and the rod g as being provided with perforations which register when the detent is in engagement with the rack, and I have shown a
30 pin I , which is adapted to enter these perforations, so that when this pin is in place, as shown in Fig. 1, the rod g cannot move endwise to disengage the detent from the rack. The pin may be held in this position by a
35 lock or a seal, or both. To this end the guide d' is provided with perforated ears d'' , lying beside the pin, and the pin is provided with a perforation adapted to be brought to register with the perforations of the ears. Through
40 these perforations may be passed the hasp of a lock or the wire or ribbon of a seal, or both. In the drawings I have shown a seal K . In addition to the pin I the pull-rod may be provided with a perforated ear I' , which lies close
45 to the perforated ear d'' at the lower side of the guide d' when the detent is in engagement with the rack, and the hasp of the lock or the seal-wire may be passed through this ear instead of or in addition to being passed through
50 the pin I .

For the purpose of preventing the bottom of the door from being moved outward away from the car I provide the door on its rear side with hooks L , which engage a rail M ,
55 disposed in a recess a in the side of the car, whereby it is concealed and protected. The rail M is held in place by castings m of approximately U shape, which straddle it at or near its ends and are secured by bolts or other
60 suitable devices to the side of the car. This permits of a slight endwise movement of the rail relatively to its fastening devices and prevents the rail from being bent should the body of the car be sprung.

65 This completes the description of the pre-

ferred form of the invention, the principal features of which are a rack carried by the car-body and a detent carried by the car-door for engaging said rack and holding said door in any
70 desired position, minor features being means for causing the detent to automatically engage the rack, means for locking or sealing, or both locking and sealing, the detent, the described
75 means for preventing the door from being moved either upward or outward, and the details above described. The invention in its broadest aspect is not, however, limited to the precise construction above described and illustrated in Figs. 1 and 2 of the drawings.

In Figs. 3 and 4 the rail F for supporting
80 the door and the rack for engagement by the detent G are shown as being formed separately instead of in one piece, as in the preferred form of the invention. Here also the
85 guide studs or projections g^3 and their accessories are dispensed with, and only one actuating-spring for the detent is used; but the principal features of the invention are nevertheless present. Again, in Fig. 5 the rack f
90 and the detent G are placed at the bottom instead of at the top of the door, the rack in this instance being formed on the front of the rail M ; but this is within the generic feature of the invention. Here also there is shown
95 a different means for manipulating the detent. Instead of the sliding pull-rod of Figs. 1 to 4, inclusive, I have here shown a lever G' , fulcrumed upon a pivot G'' , supported by the door. The handle g' is at one side of the fulcrum of the lever, and the spring H engages the
100 lever at the other side of said fulcrum, and here the lever has a perforation for receiving the sealing wire or metallic ribbon, the perforated ears d'' being located on opposite sides of it.

Heretofore in this specification the terms
105 "rack" and "detent" have been used; but these terms are not to be construed as limited to a rack or a detent of any particular type, and in Fig. 6 I have shown a rack f and a detent G differing in construction from the rack and
110 detent shown in the other figures of the drawings.

The mechanism above described will permit of the door being stopped and locked or
115 sealed, or both locked and sealed, at any desired point; but it leaves between the edge of the door and the door-jamb an open space. To close this when it is desired to do so, a
120 "lazy-tong" gate N may be used. This gate may be constructed in the manner peculiar to its class and may be mounted at one side upon a vertical rod O , fixed to the car-body, and provided at the other side with hooks, adapted to enter eyes or staples P , carried by the door,
125 one or more of said hooks being provided with a perforation for receiving the hasp of a lock or the wire or ribbon or other part of a seal.

Having thus described my invention, the following is what I claim as new therein and desire to secure by Letters Patent:

1. In a freight-car-door fastener, the combination of a horizontal rail secured to the car above the doorway and having a toothed rack, hangers secured to the door and supported by the rail, a vertically-movable detent adapted to engage said rack, a vertically-disposed rod or bar carrying said detent, means for securing said rod or bar to the door and supporting it against lateral movement while permitting its endwise movement vertically, whereby when the detent is disengaged from the rack said rod or bar affords means for moving the door in either direction, and a spring for holding said detent normally in engagement with the rack, substantially as described.

2. In a car-door fastener, the combination of a horizontal rail secured to the car above the doorway and having on its under side a toothed rack, the teeth of which are presented downward, hangers secured to the door and supported by said rail, a detent, under the control of the operator, adapted to engage said rack, a spring for holding said detent normally in engagement with the rack, a vertically-movable rod or bar carrying said detent, means for securing said rod or bar to the door and supporting it against lateral movement while permitting its free endwise movement, whereby, when the detent is disengaged from the rack-bar, said vertically-movable bar affords means for moving the door laterally in either direction, and means under the control of the operator for securing said vertically-movable rod or bar against endwise movement, the door being provided with a socket in which the spring fits, substantially as described.

3. In a car-door fastener, the combination of a rack carried by the car, a detent carried by the door and having a vertical pull-rod slidably mounted upon the door, guiding fingers or tongues carried by the detent, the door being provided with sockets in which said fingers work, and means for holding the detent in engagement with the rack, substantially as described.

4. In a car-door fastener, the combination of a rack carried by the car, a detent carried by the door and adapted to engage the rack, springs interposed between the detent and the

door, the door being provided in its upper edge with sockets in which said springs fit, and means for disengaging the detent from the rack, substantially as described.

5. In a car-door fastener, the combination of a rail secured to the car above the doorway and having on its under side a rack, and in its rear side a groove, hangers secured to the door and having rollers running upon said rail and having also depending portions entering the groove in the back of the rail, a detent carried by the door and adapted to engage the rack, and means for operating said detent, substantially as described.

6. In a car-door fastener, the combination of a rail secured to the car above the doorway, hangers secured to the door and engaging said rail whereby the door is supported, said hangers having portions which project downward behind the rail for preventing the door from moving outward, said hangers having also fingers which project forward and engage the rail whereby the door is prevented from moving outward, and means for preventing the bottom of the door from moving outward, substantially as described.

7. In a car-door fastener, the combination with the door, of a rail secured to the car, the car being provided with a groove or channel in which said rail is located, said groove or channel being open only at its outer side, and hooks carried by the door and engaging said rail, substantially as described.

8. In a car-door fastener, the combination of a rack secured to the car above the doorway and having its teeth presented downward, a detent carried by the car-door and having teeth presented upward and adapted to engage the teeth of the rack, a flange projecting downward from the detent and engaging the back of the door and a pull-rod slidably mounted upon the front side of the door, and means for locking or sealing the detent in engagement with the rack, substantially as described.

ANDREW O. ARNOLD.

Witnesses:

BELLA EVANS,
L. M. HOPKINS.