



US 20190153756A1

(19) **United States**

(12) **Patent Application Publication**  
**Huang et al.**

(10) **Pub. No.: US 2019/0153756 A1**

(43) **Pub. Date: May 23, 2019**

(54) **DOUBLE-DOOR LOCK ASSEMBLY**

**Publication Classification**

(71) Applicant: **TAIWAN FU HSING INDUSTRIAL CO., LTD.**, Kaohsiung City (TW)

(51) **Int. Cl.**  
*E05C 7/02* (2006.01)  
*E05B 15/00* (2006.01)  
*E05B 55/00* (2006.01)  
*E05B 63/14* (2006.01)

(72) Inventors: **Chao-Ming Huang**, Kaohsiung City (TW); **Yu-Cheng Lin**, Tainan City (TW)

(52) **U.S. Cl.**  
CPC ..... *E05C 7/02* (2013.01); *E05B 15/0073* (2013.01); *E05B 63/04* (2013.01); *E05B 63/143* (2013.01); *E05B 55/005* (2013.01)

(21) Appl. No.: **16/261,783**

(57) **ABSTRACT**

(22) Filed: **Jan. 30, 2019**

A double-door lock assembly includes a first lock and a second lock which are mounted to a first door and a second door, respectively. The first lock includes a first rotary member, a first magnetic member and a linkage member. The second lock includes a second rotary member having a driving portion and a second magnetic member. The first and second rotary members can be driven to rotate together to open or close the first and second doors simultaneously when the first and second magnetic members are attracted to each other and the driving portion on the second rotary member contacts against the linkage member on the first rotary member.

**Related U.S. Application Data**

(63) Continuation-in-part of application No. 15/653,680, filed on Jul. 19, 2017, now Pat. No. 10,233,669.

**Foreign Application Priority Data**

(30) May 9, 2017 (TW) ..... 106115225  
Nov. 23, 2018 (TW) ..... 107141798

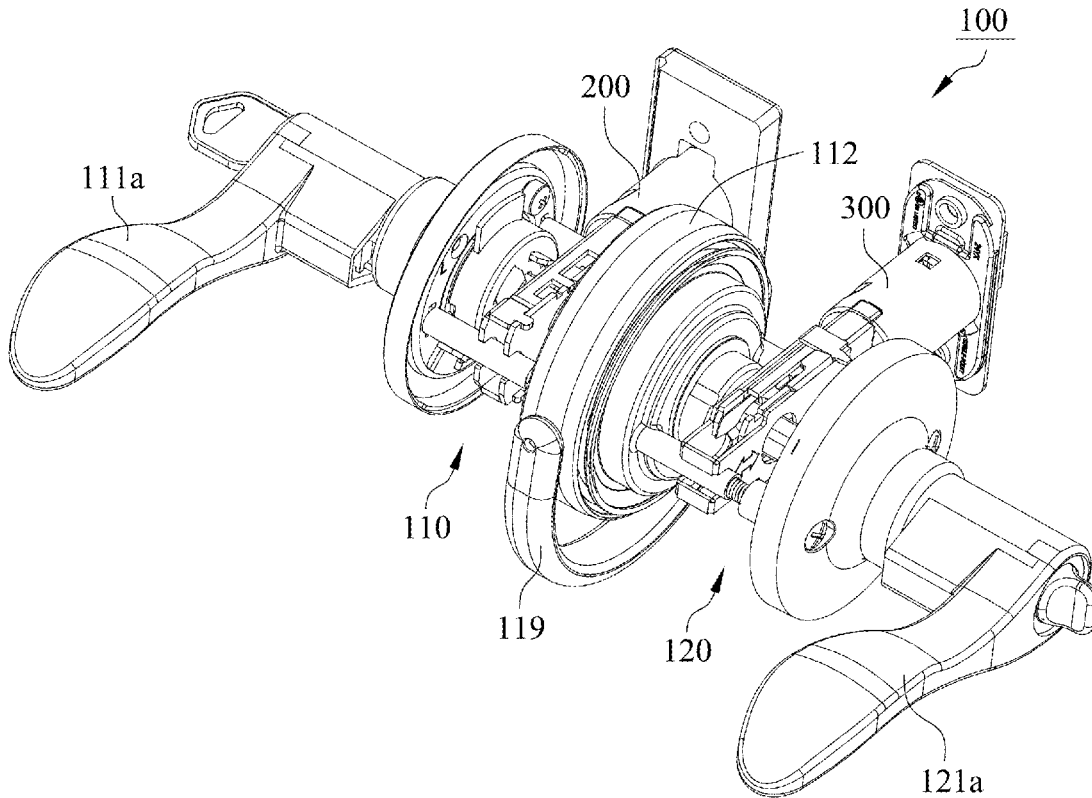

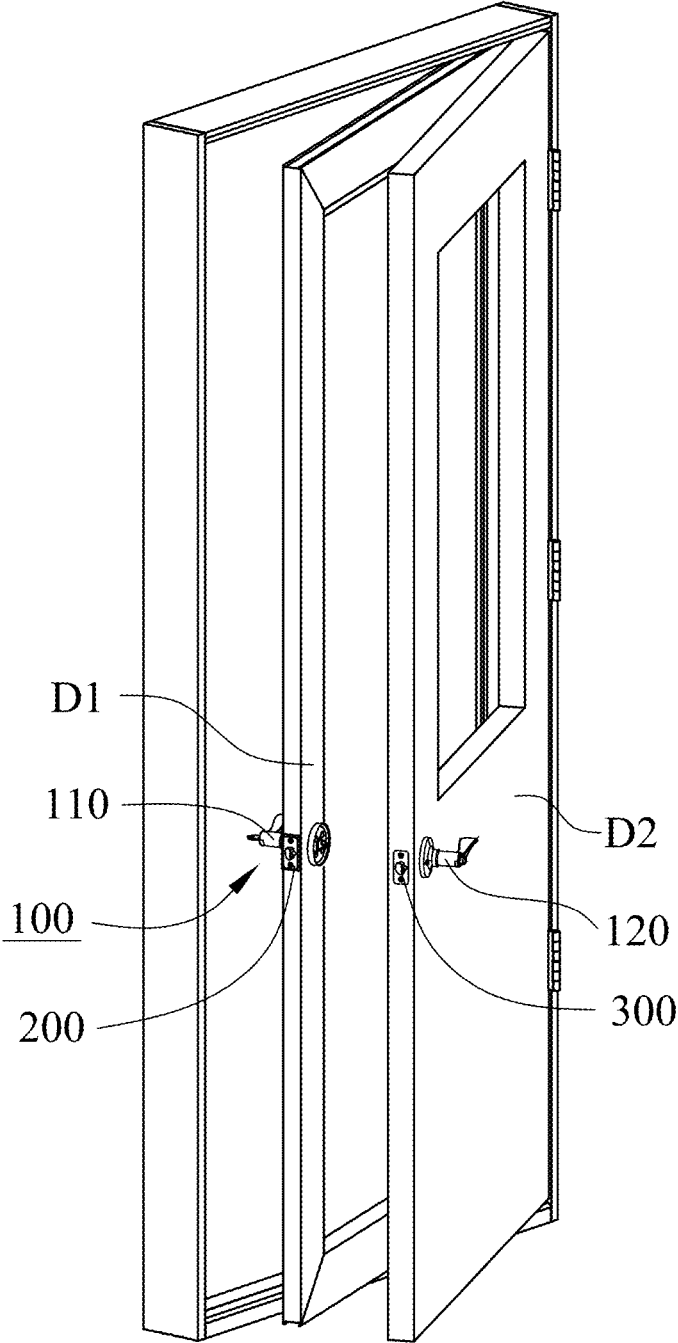

FIG. 1

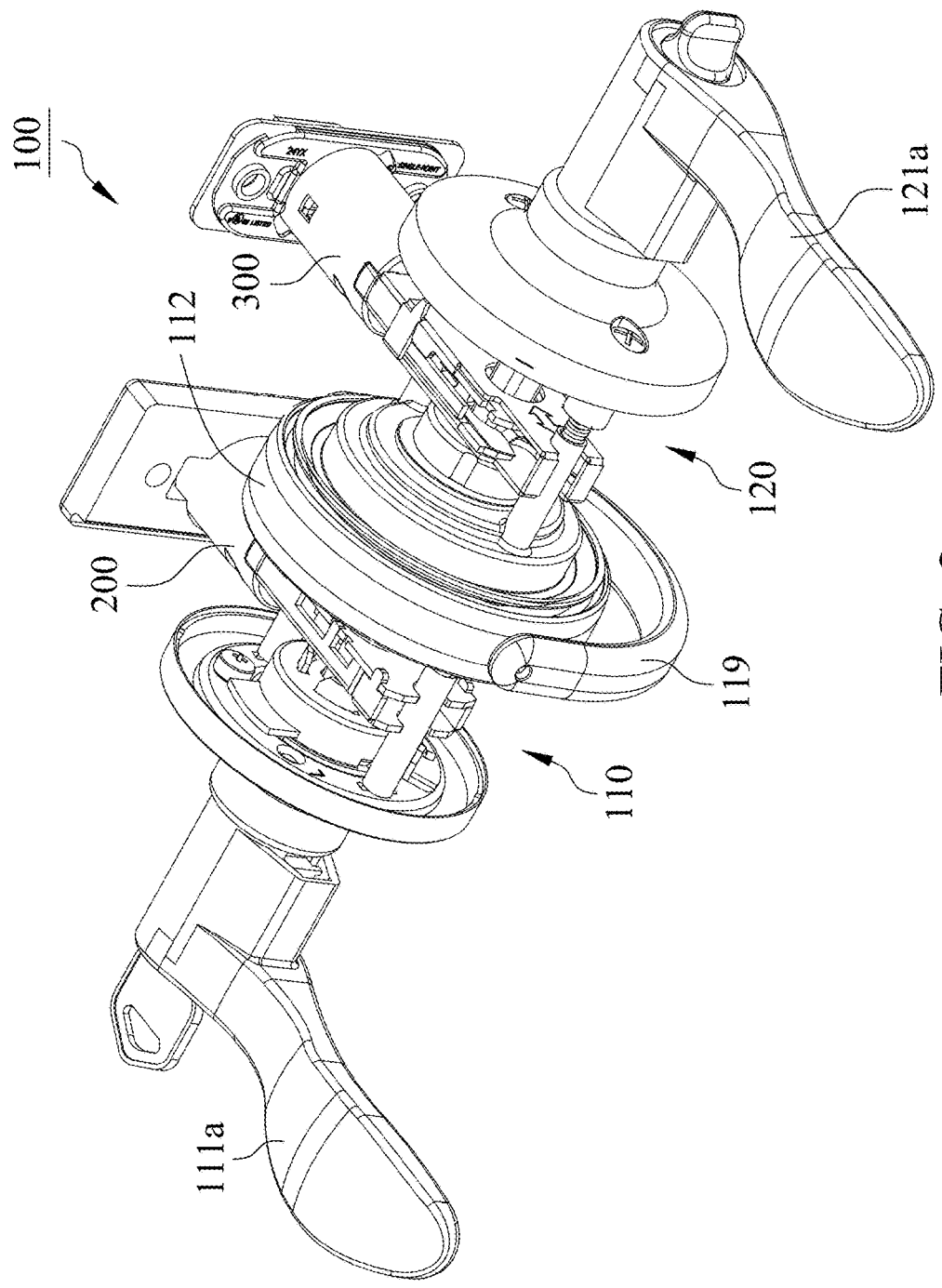

FIG. 2

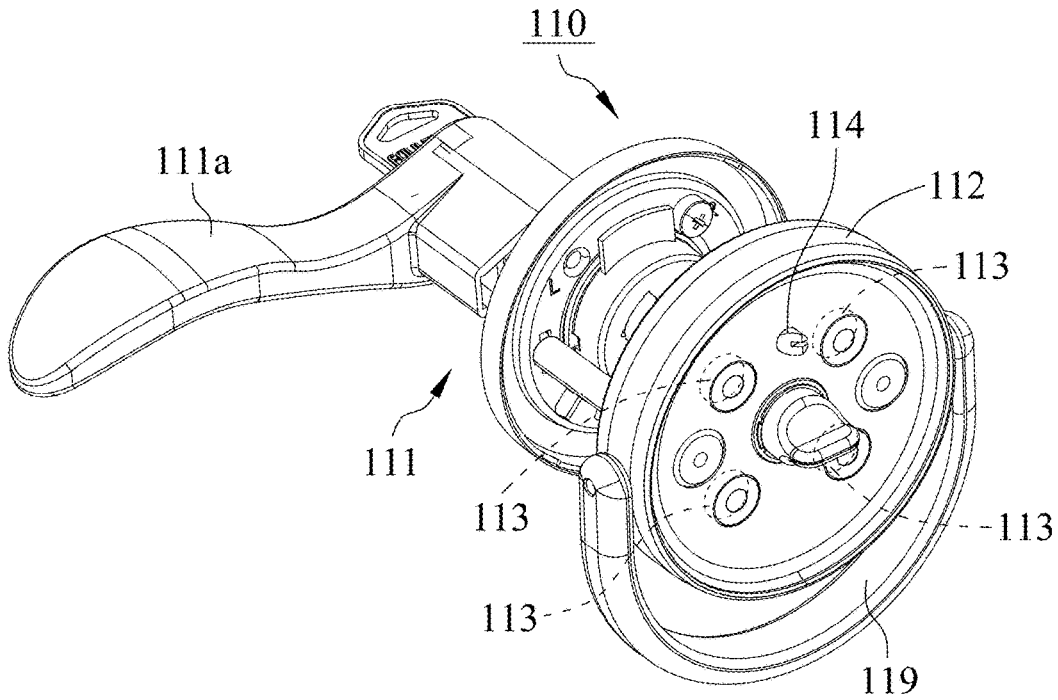

FIG. 3

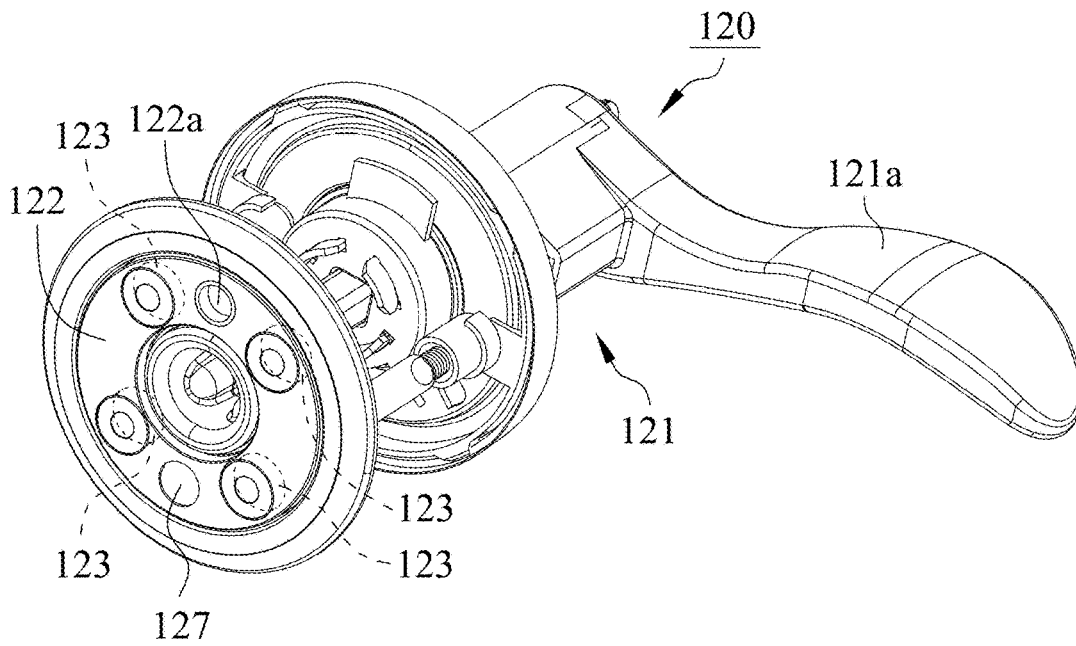

FIG. 4

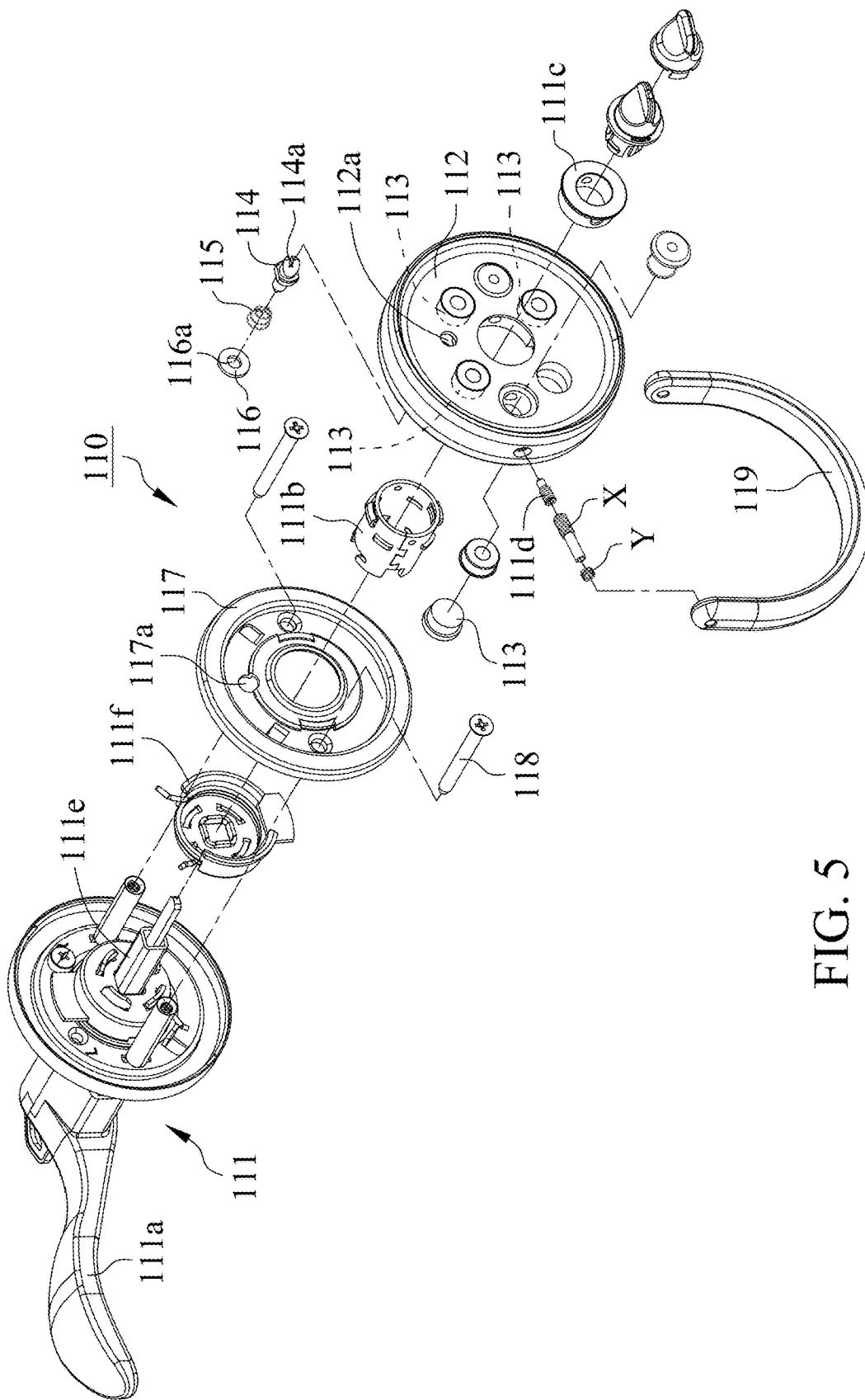

FIG. 5

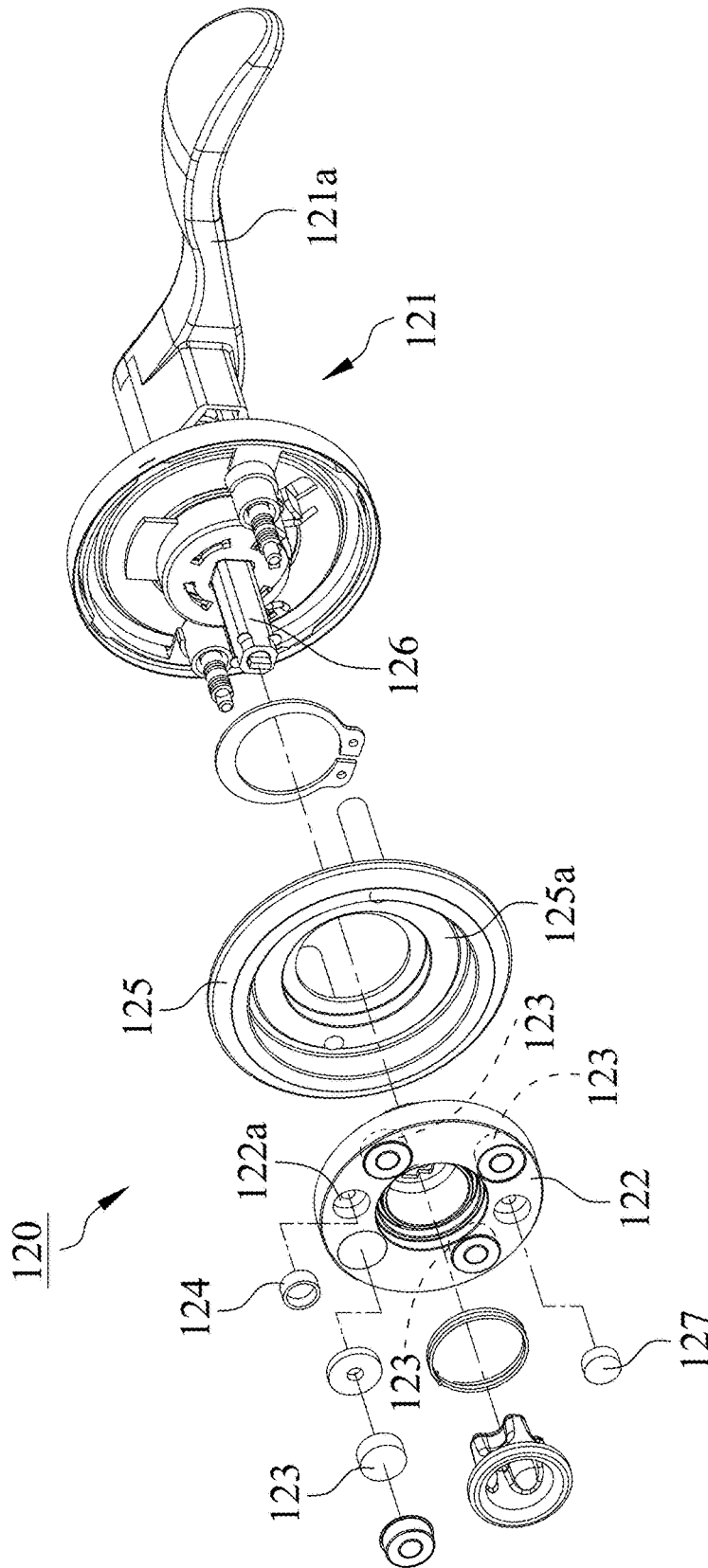

FIG. 6

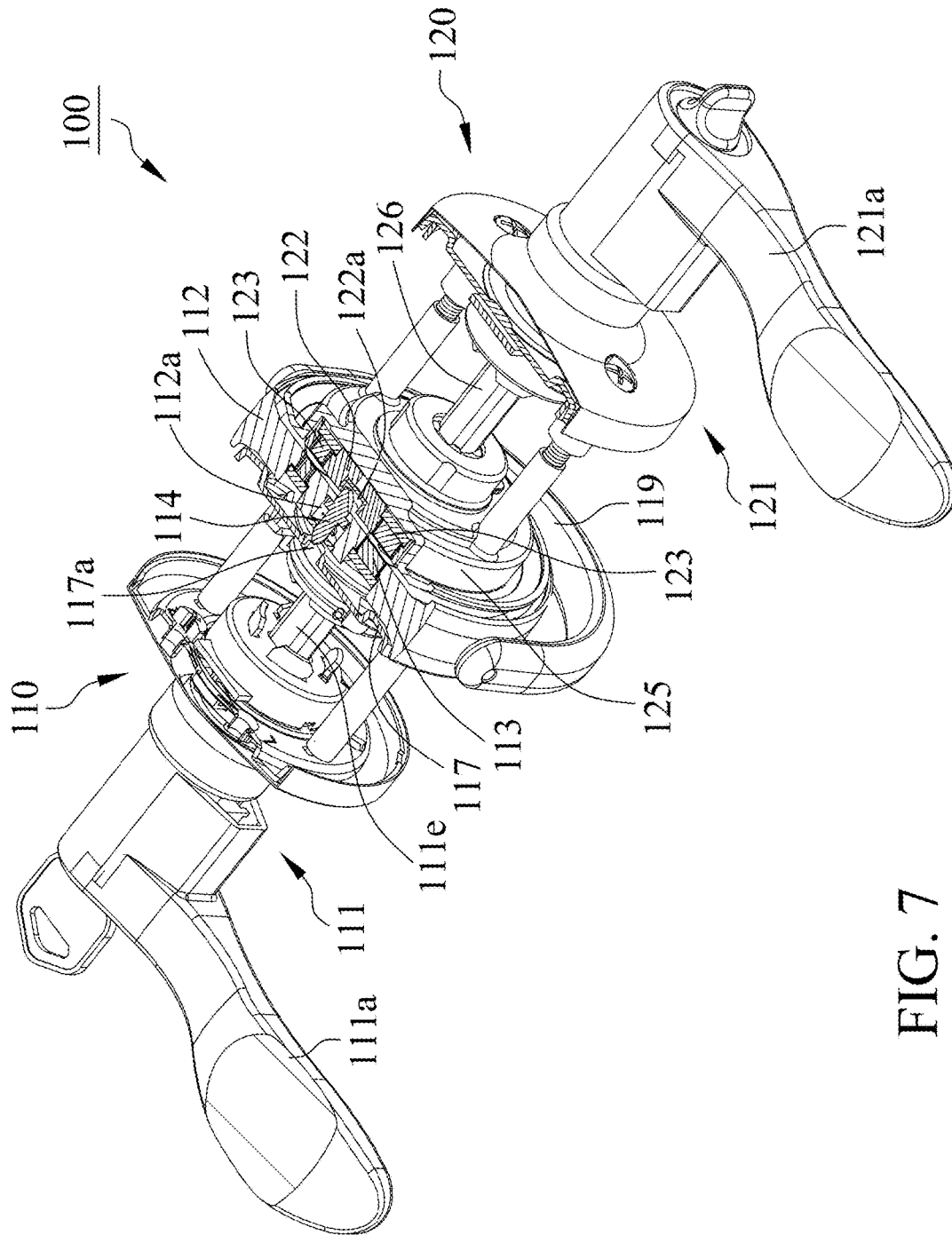

FIG. 7

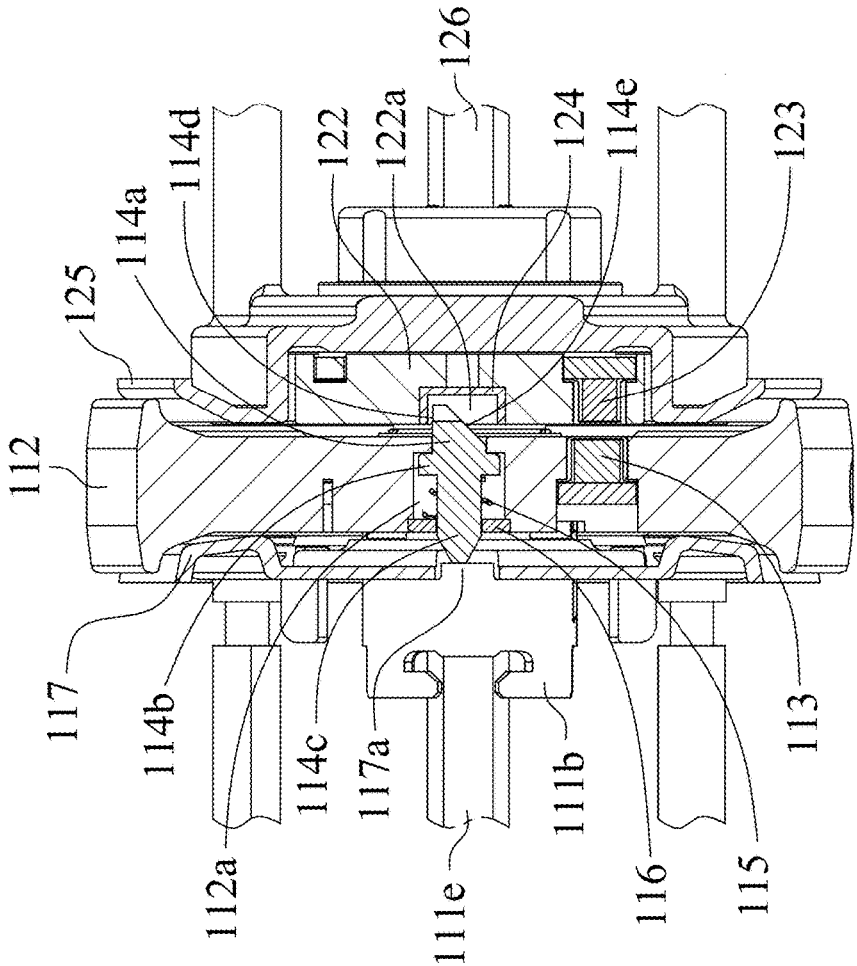

FIG. 8



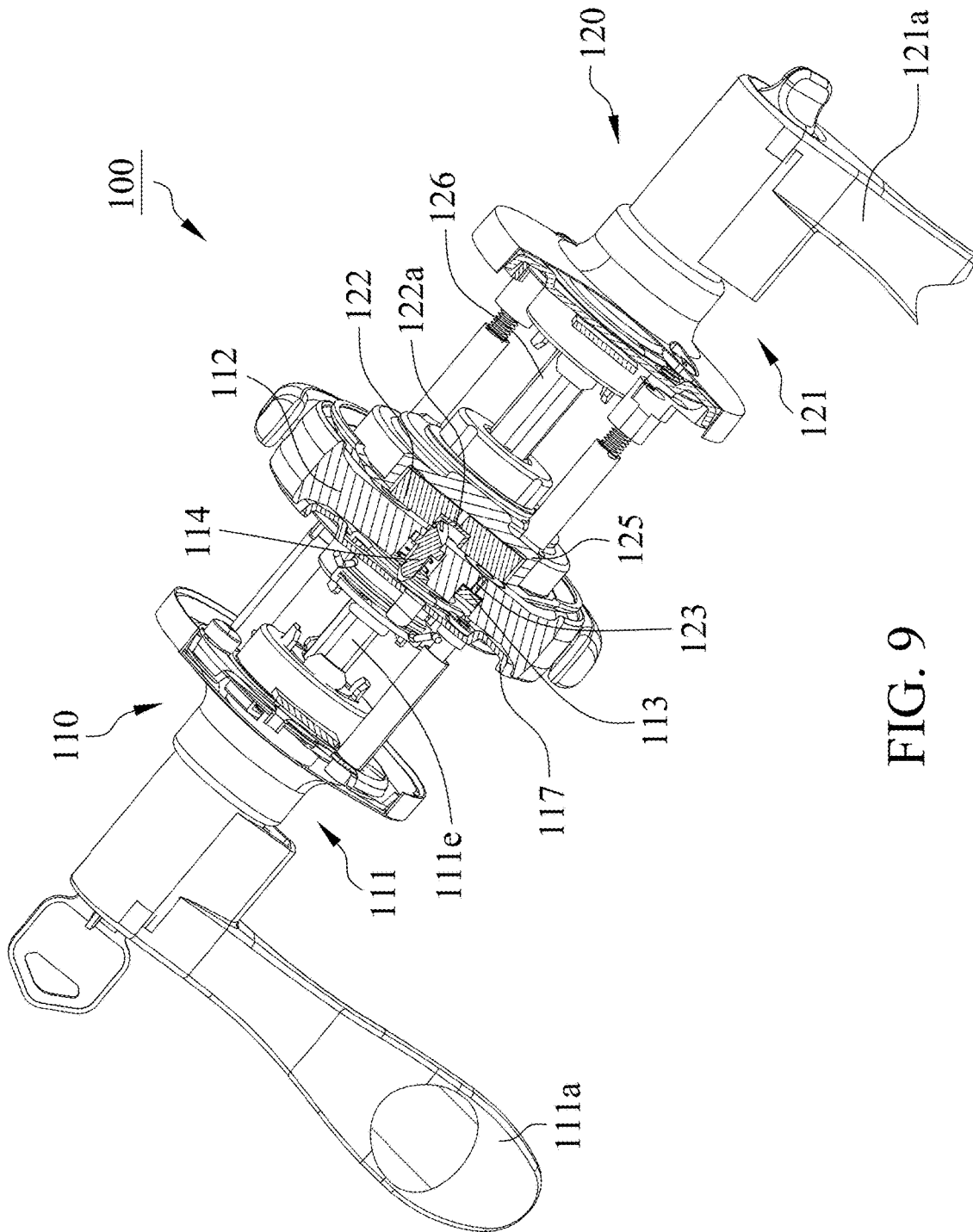

FIG. 9

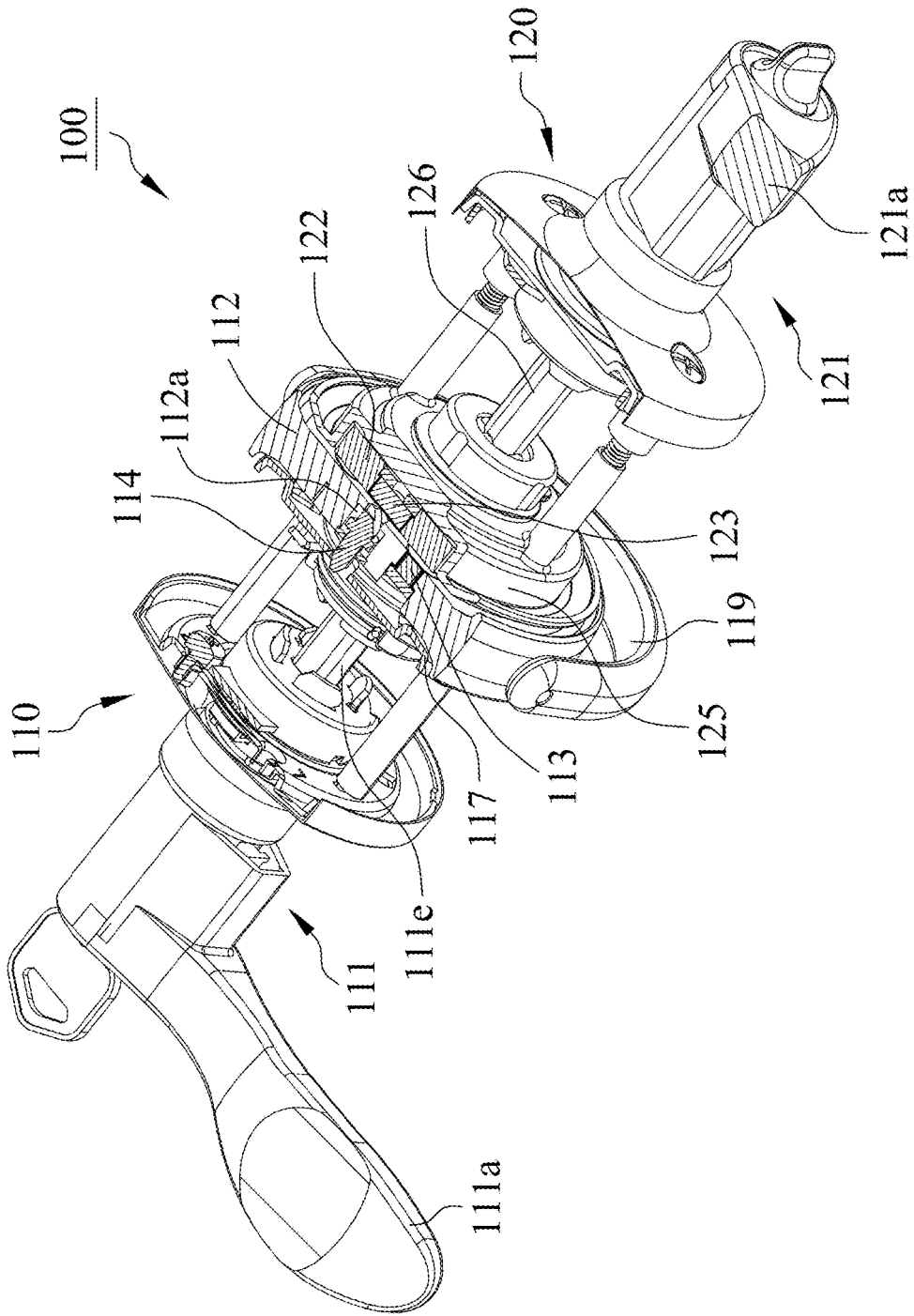

FIG. 10

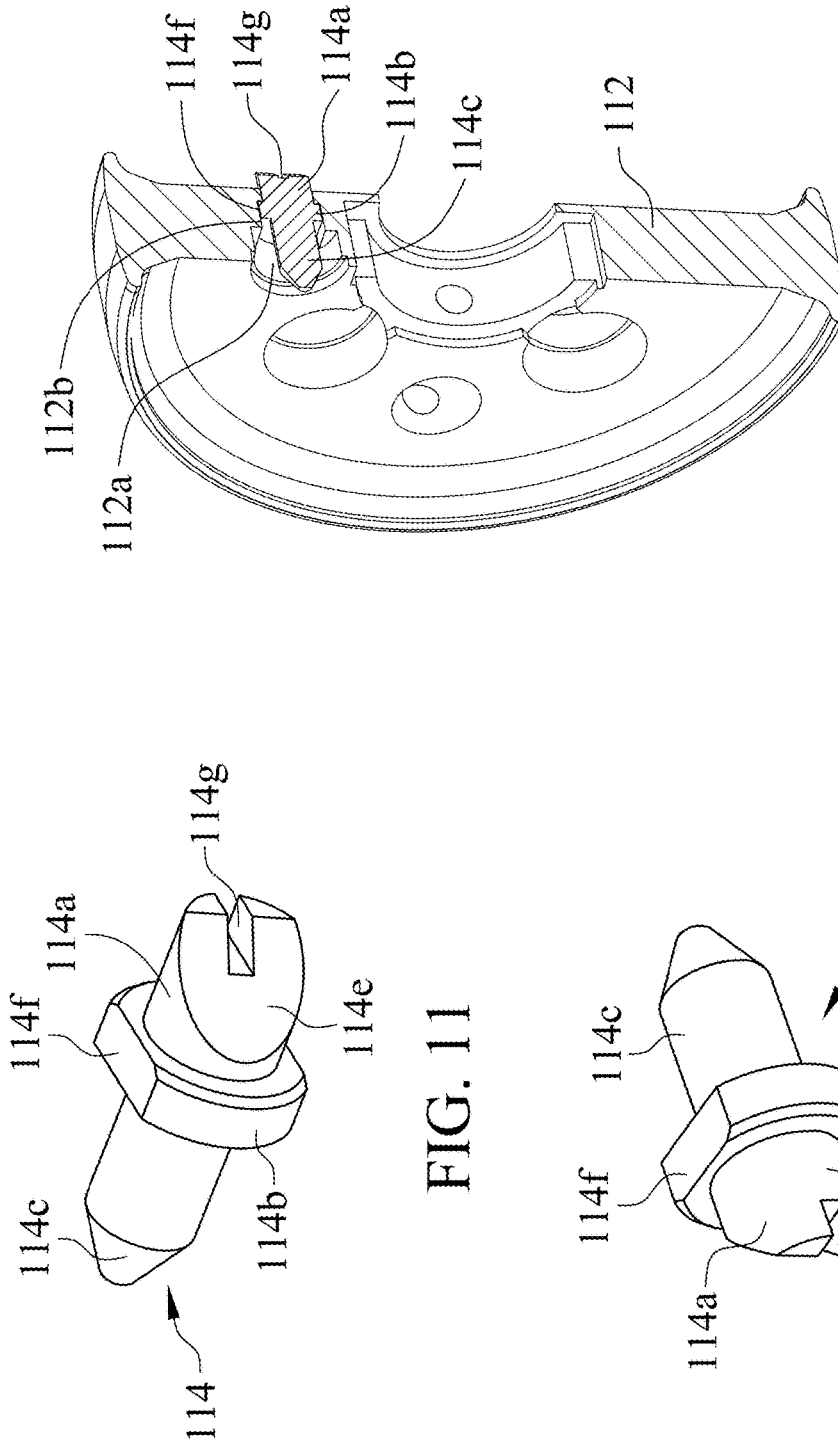

FIG. 11

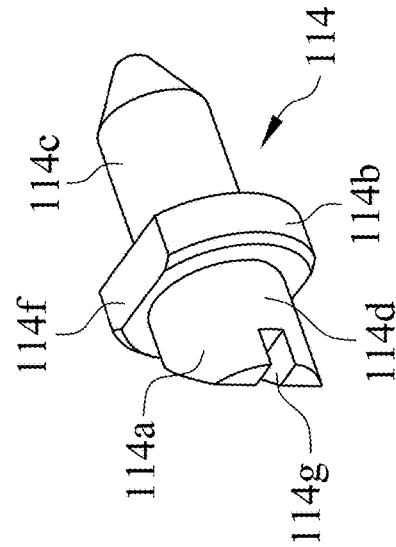

FIG. 12

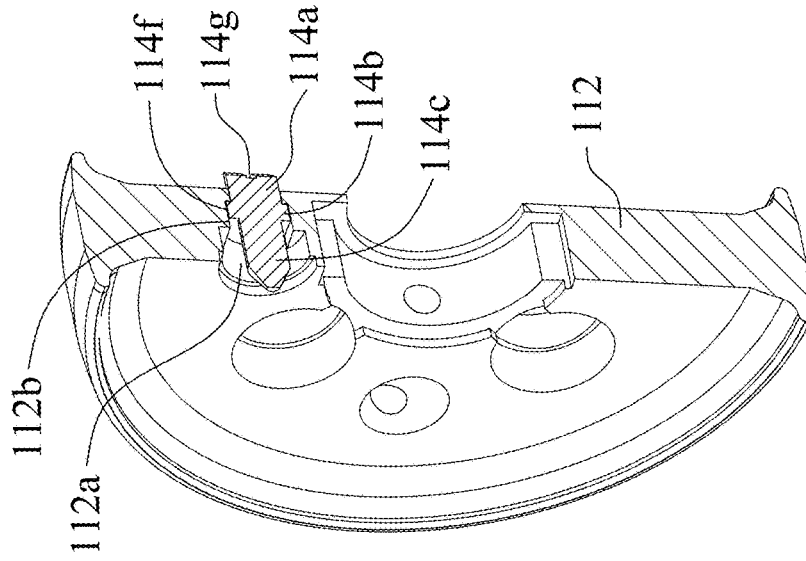

FIG. 13

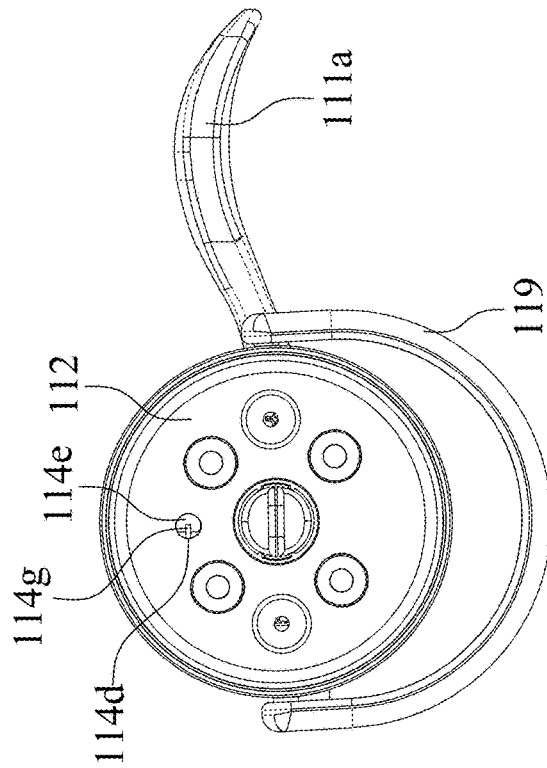

FIG. 15

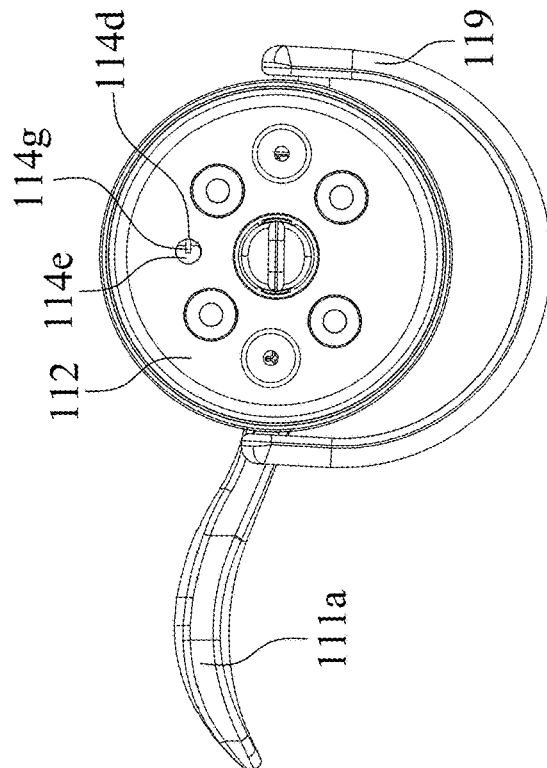

FIG. 14

## DOUBLE-DOOR LOCK ASSEMBLY

### CROSS-REFERENCE TO RELATED APPLICATIONS

**[0001]** This application is a continuation-in-part of U.S. application Ser. No. 15/653,680, filed on Jul. 19, 2017, which claims priority to Taiwan Patent Application No. 106115225, filed on May 9, 2017. This application also claims priority to Taiwan Patent Application No. 107141798, filed on Nov. 23, 2018. All of the foregoing applications are incorporated herein by reference in its entirety.

### FIELD OF THE INVENTION

**[0002]** This invention relates to a double-door lock assembly which is designed to be mounted on a first door and a second door and provided to open and close the first door and the second door simultaneously or individually.

### BACKGROUND OF THE INVENTION

**[0003]** For the purpose of burglar-proof ventilation or natural light, a first door and a second door are mounted to a door frame and a first lock and a second lock are assembled on the first and second doors, respectively. In order to open the first and second doors, user has to operate the first lock to open the first door and then operate the second lock to open the second door. That is inconvenient for use, and additionally, more space is required for the opened doors if the first and second doors are designed to be open in opposite directions.

**[0004]** In order to solve the problems mentioned above, the present inventors designed a double-door lock assembly and filed a Taiwan Patent Application No. 106115225 (now Pat. No. TW 1611089 B), a U.S. Patent Application Ser. No. 15/653,680 (now Pub. No. US 2018/0328077 A1) and a China Patent Application No. 201710539100.5 (now Pub. No. CN 108868376 A).

### SUMMARY

**[0005]** The object of the present invention is to improve cooperation reliability of first and second locks during actuation of the lock assembly.

**[0006]** One double-door lock assembly of the present invention for operating a first door and a second door simultaneously or individually comprises a first lock and a second lock. The first lock is mounted on the first door and includes a first handle set, a first rotary member rotated by the first handle set, at least one first magnetic member and a linkage member. The first magnetic member and the linkage member are disposed on and moved with the first rotary member. The linkage member is movably disposed in an accommodation hole of the first rotary member and able to be moved into or protruded from the accommodation hole. A first end of the linkage member has a blocking surface. The second lock is mounted on the second door and includes a second handle set, a second rotary member rotated by the second handle set, at least one second magnetic member and a driving portion. The second magnetic member and the driving portion are disposed on and moved with the second rotary member. When the first and second magnetic members are attracted to each other and the linkage member is protruded from the accommodation hole, the driving portion contacts against the blocking surface of

the linkage member such that the first and second rotary members are able to be rotated together.

**[0007]** Another double-door lock assembly of the present invention for operating a first door and a second door simultaneously or individually comprises a first lock and a second lock. The first lock is mounted on the first door and includes a first handle set, a first rotary member rotated by the first handle set and a linkage member disposed on and moved with the first rotary member. The linkage member is movably disposed in an accommodation hole of the first rotary member and able to be moved into or protruded from the accommodation hole. A first end of the linkage member has a blocking surface and an inclined guide surface which are located on different sides of the first end. The second lock is mounted on the second door and includes a second handle set, a second rotary member rotated by the second handle set and a driving portion disposed on and moved with the second rotary member. The first and second rotary members are able to be rotated together when the driving portion contacts against the blocking surface of the linkage member protruded from the accommodation hole. And the first and second rotary members are able to be separated from each other when the driving portion contacts against the inclined guide surface of the linkage member protruded from the accommodation hole to move the linkage member into the accommodation hole.

**[0008]** The lock assembly of the present invention utilizes the attraction between the first and second magnetic members and the mutual contacting of the linkage member on the first rotary member and the driving portion on the second rotary member to enhance cooperation reliability of the first and second locks during actuating the lock assembly.

### DESCRIPTION OF THE DRAWINGS

**[0009]** FIG. 1 is a perspective assembly diagram illustrating a lock assembly mounted on a first door and a second door in accordance with an embodiment of the present invention.

**[0010]** FIG. 2 is a perspective assembly diagram illustrating the lock assembly engaged to a latch in accordance with an embodiment of the present invention.

**[0011]** FIG. 3 is a perspective assembly diagram illustrating a first lock in accordance with an embodiment of the present invention.

**[0012]** FIG. 4 is a perspective assembly diagram illustrating a second lock in accordance with an embodiment of the present invention.

**[0013]** FIG. 5 is a perspective exploded diagram illustrating the first lock in accordance with an embodiment of the present invention.

**[0014]** FIG. 6 is a perspective exploded diagram illustrating the second lock in accordance with an embodiment of the present invention.

**[0015]** FIG. 7 is a perspective cross-section view diagram illustrating the lock assembly before actuation in accordance with an embodiment of the present invention.

**[0016]** FIG. 8 is a partial cross-section view diagram illustrating the lock assembly in accordance with an embodiment of the present invention.

**[0017]** FIG. 9 is a perspective cross-section view diagram illustrating the lock assembly when turning a second handle downwardly in accordance with an embodiment of the present invention.

[0018] FIG. 10 is a perspective cross-section view diagram illustrating the lock assembly when turning the second handle upwardly in accordance with an embodiment of the present invention.

[0019] FIG. 11 is a perspective diagram illustrating a linkage member in accordance with an embodiment of the present invention.

[0020] FIG. 12 is a perspective diagram illustrating the linkage member in accordance with an embodiment of the present invention.

[0021] FIG. 13 is a perspective cross-section view diagram illustrating the linkage member mounted on the first rotary member in accordance with an embodiment of the present invention.

[0022] FIG. 14 is a lateral view diagram illustrating the linkage member mounted on the first lock in accordance with an embodiment of the present invention.

[0023] FIG. 15 is a lateral view diagram illustrating the linkage member mounted on the first lock in accordance with an embodiment of the present invention.

#### DETAILED DESCRIPTION OF THE INVENTION

[0024] With reference to FIGS. 1 and 2, a double-door lock assembly 100 of the present invention includes a first lock 110 and a second lock 120. Similar to the related invention, published in Taiwan Pat. No. TW I611089 B, U.S. Pub. No. US 2018/0328077 A 1, and China Pub. No. CN 108868376 A and entitled “double-door lock assembly”, the first lock 110 and the second lock 120 are mounted on a first door D1 and a second door D2, respectively. The first door D1 and the second door D2 can be open and closed simultaneously or individually. In this embodiment, the first lock 110 mounted on the first door D1 is provided to actuate a first latch 200 and the second lock 120 mounted on the second door D2 is provided to actuate a second latch 300. With reference to FIGS. 3 and 5, the first lock 110 includes a first handle set 111, a first rotary member 112, at least one first magnetic member 113 and a linkage member 114. The first handle set 111 can rotate the first rotary member 112. The first magnetic member 113 and the linkage member 114 are placed on the first rotary member 112 such that they are moved with the first rotary member 112. In this embodiment, the first handle set 111 includes a first handle 111a and a shaft tube 111b, the first handle 111a is used to drive the shaft tube 111b to rotate the first rotary member 112.

[0025] With reference to FIG. 5, the first handle set 111 further preferably includes a connection member 111c and a fixing member 111d. The connection member 111c is connected to the shaft tube 111b, and the fixing member 111d is used to integrate the connection member 111c and the shaft tube 111b to the first rotary member 112 such that the first rotary member 112 can be rotated by the first handle 111a via the shaft tube 111b and the connection member 111c.

[0026] With reference to FIGS. 2 and 5, the first handle set 111 further includes a first transmission tube 111e and a transmission plate 111f. The first transmission tube 111e is engaged to the first handle 111a and inserted into the transmission plate 111f and the first latch 200, and the shaft tube 111b is engaged to the transmission plate 111f. Turning the first handle 111a will rotate the first rotary member 112 through the first transmission tube 111e, the transmission plate 111f, the shaft tube 111b and the connection member 111c to operate a latchbolt (not shown) of the first latch 200.

[0027] With reference to FIGS. 3 and 5, the linkage member 114 is movably disposed in an accommodation hole 112a of the first rotary member 112 and may be moved into or protruded from the accommodation hole 112a. In this embodiment, the first lock 110 further includes an elastic member 115 which is also disposed in the accommodation hole 112a of the first rotary member 112. The elastic member 115 is provided to push the linkage member 114 to allow a first end 114a of the linkage member 114 to protrude from the accommodation hole 112a.

[0028] With reference to FIGS. 11 and 12, in this embodiment, the first end 114a of the linkage member 114 has a blocking surface 114d and an inclined guide surface 114e which are located on different sides of the first end 114a.

[0029] With reference to FIGS. 5 and 11, the linkage member 114 of this embodiment further has a limited portion 114b and a second end 114c. The limited portion 114b is located between the first end 114a and the second end 114c, and the elastic member 115 is provided to push the limited portion 114b to flake the first end 114a protrude from the accommodation hole 112a. The first handle set 111 further preferably includes a blocking member 116 disposed on the first rotary member 112, and particularly, the blocking member 116 is disposed in the accommodation hole 112a. The elastic member 115 is retained between the restriction member 114b and the blocking member 116 so that the elastic member 115 compressed by the linkage member 114 can exert a return force to push the linkage member 114.

[0030] With reference to FIGS. 11, 12 and 13, a first limitation surface 112b in the accommodation hole 112a of the first rotary member 112 is designed to limit the limited portion 114b of the linkage member 114. In this embodiment, the first limitation surface 112b is designed to stop the rotation of the linkage member 114 in the accommodation hole 112a by limiting a second limitation surface 114f of the limited portion 114b.

[0031] With reference to FIGS. 3 and 5, the first lock 110 includes a mounting plate 117 which is engaged with the first handle set 111 by using at least one fixing rod 118, such that the mounting plate 117 will not be rotated by the first handle set 111. In this embodiment, the mounting plate 117 has a relief hole 117a aligned with the linkage member 114 and the blocking member 116 has a through hole 116a aligned with the linkage member 114 and the relief hole 117a. Besides, the first lock 110 further includes a driving handle 119 connected to the first rotary member 112 by using an adjusting screw X and a spring Y. The driving handle 119 is used to drive the first rotary member 112 while the first door D1 and the second door D2 are open individually.

[0032] With reference to FIGS. 4 and 6, the second lock 120 includes a second handle set 121, a second rotary member 122, at least one second magnetic member 123 and a driving portion 122a. The second handle set 121 is used to drive the second rotary member 122 in rotation, the second magnetic member 123 and the driving portion 122a are disposed on the second rotary member 122 and moved with the second rotary member 122. The driving portion 122a may be a recess or rib, and in this embodiment, the driving portion 122a is a recess. The second lock 120 further preferably includes a collar 124 disposed in the recess.

[0033] With reference to FIGS. 4 and 6, the second handle set 121 includes a second handle 121a and the second lock 120 further includes a base 125 and a second transmission

tube **126** in this embodiment. The base **125** is fixed on the second handle set **121** and will not be rotated by the second handle set **121**.

**[0034]** The second rotary member **122** is rotatably received in a receiving groove **125a** of the base **125**. Both ends of the second transmission tube **126** are engaged to the second handle **121a** and the second rotary member **122**, respectively, and the second latch **300** is set on the second transmission tube **126**. User can turn the second handle **121a** to rotate the second rotary member **122** via the second transmission tube **126** and actuate a latchbolt (not shown) of the second latch **300**.

**[0035]** With reference to FIGS. **7** and **8**, the first lock **110** and the second lock **120** are attracted to each other by using the first magnetic member **113** and the second magnetic member **123**.

**[0036]** With reference to FIGS. **7**, **8** and **9**, while the first end **114a** of the linkage member **114** is protruded from the accommodation hole **112a** and the first magnetic member **113** is attracted to the second magnetic member **123**, turning the second handle **121a** downwardly can drive the second transmission tube **126** to rotate the second rotary member **122** and actuate the latchbolt (not shown) of the second latch **300** and can move the driving portion **122a** to contact against the blocking surface **114d** of the linkage member **114** protruded from the accommodation hole **112a**. Accordingly, the linkage member **114** can drive the first rotary member **112** to rotate with the second rotary member **122** and also drive the shaft tube **111b**, the transmission plate **111f** and the first transmission tube **111e** to rotate with the first rotary member **111b**. By the attraction of the first magnetic member **113** and the second magnetic member **123** and the linkage member **114** pushed by the driving portion **122a**, the second rotary member **122** and the first rotary member **112** can be rotated together. The first rotary member **112** can drive the first transmission tube **111e** to actuate the latchbolt (not shown) of the first latch **200** to open or close the first door **D1** and the second door **D2** simultaneously.

**[0037]** With reference to FIGS. **7**, **8** and **9**, the linkage member **114** on the first rotary member **112** of the first lock **110** and the driving portion **122a** on the second rotary member **122** of the second lock **120** are utilized to improve cooperation reliability of the first lock **110** and the second lock **120** when actuating the lock assembly **100**.

**[0038]** With reference to FIGS. **7** and **8**, similarly, rotating the first handle **111a** downwardly can drive the rotation of the first rotary member **112**. When the first rotary member **112** is rotated and the driving portion **122a** is moved to contact against the blocking surface **114d** of the linkage member **114**, the linkage member **114**, which is rotated with the first rotary member **112** and unable to move into the accommodation hole **112a** due to a second end **114c** of the linkage member **114** contacts against the mounting plate **117**, can drive the second rotary member **122** and the second transmission tube **126** to rotate. The synchronize rotation of the first rotary member **112** and the second rotary member **122** result from the first end **114a** of the linkage member **114** contacting with the driving portion **122a** realizes the synchronize operation of the first door **D1** and the second door **D2**.

**[0039]** With reference to FIGS. **7**, **8** and **10**, turning the second handle **121a** upwardly also can rotate the second rotary member **122** via the second transmission tube **126**. However, when the second rotary member **122** is rotated to

lead the driving portion **122a** to press the inclined guide surface **114e** of the linkage member **114**, the second magnetic member **123** is moved with the second rotary member **122** to misalign the first magnetic member **113** and the linkage member **114** is pushed into the accommodation hole **112a** of the first rotary member **112** by the driving portion **122a** of the second rotary member **122**. In this embodiment, the driving portion **122a** can press the inclined guide surface **114a** of the linkage member **114** to force the first end **114a** of the linkage member **114** into the accommodation hole **112a** of the first rotary member **112** and force the second end **114c** of the linkage member **114** into the relief hole **117a** of the mounting plate **117** so that the second rotary member **122** can be detached from the first rotary member **112** to separate the second lock **120** from the first lock **110** to open or close the first door **D1** and the second door **D2** individually.

**[0040]** With reference to FIGS. **3**, **4**, **5** and **6**, the second lock **120** further includes at least one third magnetic member **127** disposed on the second rotary member **122**. When the first magnetic member **113** and the second magnetic member **123** are misaligned due to the first rotary member **112** or the second rotary member **122** is rotated, the third magnetic member **127** corresponds and repels with the first magnetic member **113** and the linkage member **114** is pushed into the accommodation hole **112a** of the first rotary member **112** by the driving portion **122a** so as to separate the second rotary member **122** from the first rotary member **112**.

**[0041]** With reference to FIGS. **7** and **8**, different to the second handle **121a**, pulling the first handle **111a** upwardly can't separate the first rotary member **112** from the second rotary member **122**. The first rotary member **112** and the linkage member **114** are rotated by the pulled-up first handle **111a**, but the linkage member **114** is unable to be moved into the accommodation hole **112a** because the second end **114c** of the linkage member **114** contacts against the mounting plate **117** and the first rotary member **112** is unable to be rotated by the first handle set **111** owing to the blocking surface **114d** contacts against the driving portion **122a**. As a result, pulling up the first handle **111a** can't separate the first lock **110** from the second lock **120**.

**[0042]** With reference to FIGS. **11**, **12**, **13** and **14**, the lock assembly **100** is able to be mounted on left and right hand door by a recessed groove **114g** on the first end **114a** of the linkage member **114**. Referring to FIGS. **3**, **14** and **15**, when a tool (not shown) is inserted into the recessed groove **114g** to press the linkage member **114** inwardly, the second limitation surface **114f** of the limited portion **114b** is moved away from the first limitation surface **112h** of the accommodation hole **112a** such that the linkage member **114** is rotatable to allow the lock assembly **100** to be mounted on left or right hand door. While this invention has been particularly illustrated and described in detail with respect to the preferred embodiments thereof it will be clearly understood by those skilled in the art that is not limited to the specific features shown and described and various modified and changed in form and details may be made without departing from the spirit and scope of this invention.

What is claimed is:

**1.** A lock assembly for operating a first door and a second door simultaneously or individually, the lock assembly comprising:

a first lock designed to be mounted to the first door and including a first handle set, a first rotary member rotated by the first handle set, at least one first magnetic

- member and a linkage member, the at least one first magnetic member and the linkage member are disposed on and moved with the first rotary member, the linkage member is movably disposed in an accommodation hole of the first rotary member and able to be moved into or protruded from the accommodation hole, a first end of the linkage member has a blocking surface; and
- a second lock designed to be mounted to the second door and including a second handle set, a second rotary member rotated by the second handle set, at least one second magnetic member and a driving portion, the at least one second magnetic member and the driving portion are disposed on and moved with the second rotary member, wherein when the at least one first magnetic member and the at least one second magnetic member are attracted to each other and the linkage member is protruded from the accommodation hole, the driving portion contacts against the blocking surface of the linkage member such that the first and second rotary members are able to be rotated simultaneously.
2. The lock assembly in accordance with claim 1, wherein the first end of the linkage member has an inclined guide surface, and the inclined guide surface and the blocking surface are located on different sides of the first end.
3. The lock assembly in accordance with claim 2, wherein when the first rotary member or the second rotary member is rotated to misalign the at least one first magnetic member and the at least one second magnetic member, the driving portion contacts against the linkage member to move the linkage member into the accommodation hole of the first rotary member such that the first rotary member and the second rotary member are able to be separated from each other.
4. The lock assembly in accordance with claim 3, wherein at least one third magnetic member is disposed on the second rotary member and repelled by the at least one first magnetic member.
5. The lock assembly in accordance with claim 1, wherein the first lock further includes a mounting plate which is engaged to the first handle set and unable to be rotated by the first handle set, a second end of the linkage member contacts against the mounting plate to stop the movement of the linkage member into the accommodation hole when the first rotary member is rotated and the driving portion contacts against the blocking surface of the linkage member.
6. The lock assembly in accordance with claim 3, wherein the first lock further includes a mounting plate which is engaged to the first handle set and unable to be rotated by the first handle set, a second end of the linkage member is moved in a relief hole of the mounting plate when the second rotary member is rotated and the driving portion contacts against the inclined guide surface of the linkage member.
7. The lock assembly in accordance with claim 1, wherein the first lock further includes an elastic member disposed in the accommodation hole of the first rotary member, the elastic member is used to push the linkage member such that the first end of the linkage member is protruded from the accommodation hole.
8. The lock assembly in accordance with claim 7, wherein the linkage member includes a limited portion and a second end, the limited portion is located between the first and second ends and pushed by the elastic member.
9. The lock assembly in accordance with claim 8, wherein the first lock further includes a blocking member disposed on the first rotary member, the elastic member is retained between the limited portion and the blocking member.
10. The lock assembly in accordance with claim 8, wherein there is a first limitation surface in the accommodation hole for limiting a second limitation surface on the limited portion of the linkage member.
11. The lock assembly in accordance with claim 1, wherein a recessed groove is formed on the first end of the linkage member.
12. The lock assembly in accordance with claim 1, wherein the first handle set includes a shaft tube, a connection member connected to the shaft tube and a fixing member, and the connection member and the shaft tube are integrated to the first rotary member by the fixing member.
13. The lock assembly in accordance with claim 1, wherein the driving portion is a recess or a rib.
14. A lock assembly for operating a first door and a second door simultaneously or individually, the lock assembly comprising:
- a first lock designed to be mounted to the first door and including a first handle set, a first rotary member rotated by the first handle set and a linkage member disposed on and moved with the first rotary member, the linkage member is moveably disposed in an accommodation hole of the first rotary member and able to be moved into or protruded from the accommodation hole, a first end of the linkage member has a blocking surface and an inclined guide surface located on different sides of the first end; and
- a second lock designed to be mounted to the second door and including a second handle set, a second rotary member rotated by the second handle set and a driving portion disposed on and moved with the second rotary member, wherein the first and second rotary members are able to be rotated simultaneously when the driving portion contacts against the blocking surface of the linkage member protruded from the accommodation hole, and wherein the first and second rotary members are able to be separated from each other when the driving portion contacts against the inclined guide surface of the linkage member protruded from the accommodation hole to push the linkage member into the accommodation hole.
15. The lock assembly in accordance with claim 14, wherein the first lock further includes a mounting plate which is engaged to the first handle set and unable to be rotated by the first handle set, a second end of the linkage member contacts against the mounting plate to stop the movement of the linkage member into the accommodation hole when the first rotary member is rotated and the driving portion contacts against the blocking surface of the linkage member.
16. The lock assembly in accordance with claim 14, wherein the first lock further includes a mounting plate which is engaged to the first handle set and unable to be rotated by the first handle set, a second end of the linkage member is moved in a relief hole of the mounting plate when the second rotary member is rotated and the driving portion contacts against the inclined guide surface of the linkage member.
17. The lock assembly in accordance with claim 14, wherein the first lock further includes an elastic member disposed in the accommodation hole of the first rotary member, the elastic member is used to push the linkage



member such that the first end of the linkage member is protruded from the accommodation hole.

**18.** The lock assembly in accordance with claim **17**, wherein the linkage member includes a limited portion and a second end, the limited portion is located between the first and second ends and pushed by the elastic member.

**19.** The lock assembly in accordance with claim **18**, wherein the first lock further includes a blocking member disposed on the first rotary member, the elastic member is retained between the limited portion and the blocking member.

**20.** The lock assembly in accordance with claim **18**, wherein there is a first limitation surface in the accommodation hole for limiting a second limitation surface on the limited portion of the linkage member.

**21.** The lock assembly in accordance with claim **14**, wherein a recessed groove is formed on the first end of the linkage member.

**22.** The lock assembly in accordance with claim **14**, wherein the first handle set includes a shaft tube, a connection member connected to the shaft tube and a fixing member, and the connection member and the shaft tube are integrated to the first rotary member by the fixing member.

**23.** The lock assembly in accordance with claim **14**, wherein the driving portion is a recess or a rib.

\* \* \* \* \*