



- (51) **International Patent Classification:**  
*E05B 3/06* (2006.01) *E05B 63/04* (2006.01)
- (21) **International Application Number:**  
PCT/IT2013/000360
- (22) **International Filing Date:**  
23 December 2013 (23.12.2013)
- (25) **Filing Language:** Italian
- (26) **Publication Language:** English
- (71) **Applicant:** CISA S.P.A. [IT/IT]; Via Guglielmo Oberdan, 42, I-48018 Faenza (IT).
- (72) **Inventors:** FUSTINI, Fausto; Via Degli Sminatori, 68, I-40026 Imola (IT). BASAVARAJ, Vrashabhendra; 427,8th B Main Road 1 Block, 560043 Kalyan Nagar, Bangalore (IN). KLOSTERMEIER, Manfred; Hofackerstrasse 1, D-78056 Villingen-Schwenningen (DE). HOMBERG, Martin; Nikolaus-Ehlen-Weg 26, 77652 Offenbourg (DE). MATTOGNO, Gianluca; Via Oberdan 5, 62014 Matelica (IT).
- (74) **Agent:** MODIANO, Micaela; Modiano & Partners, Via Meravigli, 16, I-20123 Milano (IT).

- (81) **Designated States** (unless otherwise indicated, for every kind of national protection available): AE, AG, AL, AM, AO, AT, AU, AZ, BA, BB, BG, BH, BN, BR, BW, BY, BZ, CA, CH, CL, CN, CO, CR, CU, CZ, DE, DK, DM, DO, DZ, EC, EE, EG, ES, FI, GB, GD, GE, GH, GM, GT, HN, HR, HU, ID, IL, IN, IR, IS, JP, KE, KG, KN, KP, KR, KZ, LA, LC, LK, LR, LS, LT, LU, LY, MA, MD, ME, MG, MK, MN, MW, MX, MY, MZ, NA, NG, NI, NO, NZ, OM, PA, PE, PG, PH, PL, PT, QA, RO, RS, RU, RW, SA, SC, SD, SE, SG, SK, SL, SM, ST, SV, SY, TH, TJ, TM, TN, TR, TT, TZ, UA, UG, US, UZ, VC, VN, ZA, ZM, ZW.
- (84) **Designated States** (unless otherwise indicated, for every kind of regional protection available): ARIPO (BW, GH, GM, KE, LR, LS, MW, MZ, NA, RW, SD, SL, SZ, TZ, UG, ZM, ZW), Eurasian (AM, AZ, BY, KG, KZ, RU, TJ, TM), European (AL, AT, BE, BG, CH, CY, CZ, DE, DK, EE, ES, FI, FR, GB, GR, HR, HU, IE, IS, IT, LT, LU, LV, MC, MK, MT, NL, NO, PL, PT, RO, RS, SE, SI, SK, SM, TR), OAPI (BF, BJ, CF, CG, CI, CM, GA, GN, GQ, GW, KM, ML, MR, NE, SN, TD, TG).

**Published:**  
— with international search report (Art. 21(3))

(54) **Title:** NON-HANDED HANDLE ASSEMBLY AND ASSOCIATED SELECTION APPARATUS

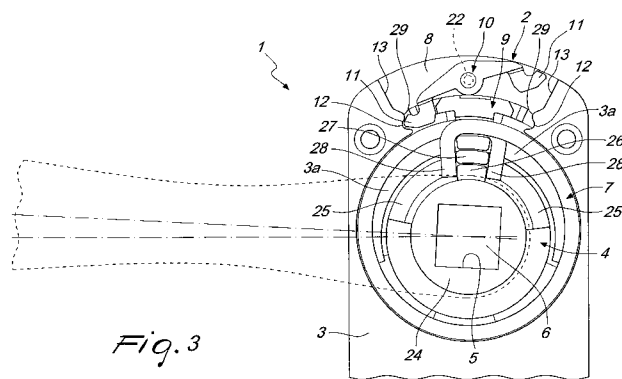

Fig. 3

(57) **Abstract:** A non-handed handle assembly (1) of the type comprising a main body (3) for rotatable accommodation of a carousel (4), provided with a substantially central seat (5) for the accommodation of the transverse stem (6) of a handle, elastic means (7) for contrasting the free rotation of the carousel (4) being interposed between the carousel (4) and the main body (3). The body (3) comprises a hollow (8) whose shape and dimensions are complementary to those of a contoured insert (9), the hollow (8) having a larger angular extent than the insert (9) rotatably accommodated therein; a rocker (10) that is pivoted centrally proximate to the hollow (8) has respective contoured ends (11), which oscillate between a first configuration for detachable interlocking of a first end (11) within a respective first receptacle (12) of the edge (13) of the hollow (8) and a second configuration for detachable interlocking of a second end (11) within a respective second receptacle (12) that is opposite the first one. The insert (9) abuts against at least one of the first end and the second end (11) in one of the first configuration and the second configuration, with consequent partially rotated arrangement thereof. At least one portion of the carousel (4) and at least one portion of the insert (9) are coupled by means of respective elastic means (7).



## NON-HANDED HANDLE ASSEMBLY AND ASSOCIATED SELECTION APPARATUS

The present invention relates to a non-handed handle assembly and to an associated selection apparatus.

5 It is known that it is possible to use handle assemblies that are capable of actuating the spring latch of a lock.

Applying a moment to the handle that produces a rotation thereof causes the retraction of the spring latch of the lock.

10 Unfortunately, however, traditional handle assemblies are generally provided for one-handed installations: in practice, a handle assembly can allow the rotation of the handle either clockwise or counterclockwise.

The rotation of the handle is closely correlated to the opening direction of the door in which it is installed: it is therefore necessary to provide handles that rotate counterclockwise in left-swing doors (left-swing  
15 opening being understood as the opening of a door which, when pushed, rotates by moving its end to the left) and handles that rotate clockwise in right-swing doors (right-swing opening being understood as the opening of a door which, when pushed, rotates by moving its end to the right).

20 For each specific installation (with a handle having clockwise or counterclockwise rotation) there is always an inclination of said handle, so that its end is slightly higher than its pivoting axis.

In practice, the longitudinal axis of the grip portion of the handle lies on a plane that is inclined (with respect to the horizontal plane) and has a height that increases progressively from the portion that is aligned with the  
25 pivoting axis to the opposite free end.

This arrangement is intended to facilitate the grip and application of the force required to rotate the handle (in contrast to specific elastic means).

30 There are some embodiments of handle assemblies that allow the rotation of the handle in both directions; however, they do not allow a placement of the handle according to the traditional inclination and

therefore are awkward and unnatural for users.

The aim of the present invention is to solve the problems described above, providing a non-handed handle assembly that can be installed equally on a right-swing door or on a left-swing door, allowing comfortable  
5 use of the handle by the user.

Within the scope of this aim, an object of the invention is to propose a non-handed handle assembly that allows the installation of the handle equally on right-swing and left-swing according to standardized position and inclination criteria.

10 Another object of the invention is to propose a corresponding selection apparatus that makes a handle assembly that comprises it suitable for use equally on right-swing or left-swing doors.

Another object of the invention is to propose a corresponding selection apparatus that makes it possible to configure a handle assembly  
15 that comprises it according to the two different installation possibilities, indicated for right-swing and left-swing doors, repeating this configuration even multiple times.

A further object of the present invention is to provide a non-handed handle assembly and a corresponding selection apparatus that have a low  
20 cost, are relatively simple to provide in practice and are safe in application.

This aim, as well as these and other objects that will become more apparent hereinafter, are achieved by a non-handed handle assembly of the type comprising a main body for rotatable accommodation of a carousel, provided with a substantially central seat for the accommodation of the  
25 transverse stem of a handle, elastic means for contrasting the free rotation of said carousel being interposed between said carousel and said main body, characterized in that said body comprises a hollow whose shape and dimensions are complementary to those of a contoured insert, said hollow having a larger angular extent than said insert rotatably accommodated  
30 therein, a rocker that is pivoted centrally proximate to said hollow having

respective contoured ends, which oscillate between a first configuration for detachable interlocking of a first end within a respective first receptacle of the edge of said hollow and a second configuration for detachable interlocking of a second end within a respective second receptacle that is  
5 opposite the first one, said insert abutting against at least one of said first end and said second end in one of the first configuration and the second configuration, with consequent partially rotated arrangement thereof.

This aim and these and other objects are also achieved by a corresponding selection apparatus for handle assemblies, characterized in  
10 that it comprises a carousel that can rotate within a seat of a main body provided with a hollow whose shape and dimensions are complementary to those of a contoured insert, said hollow having a larger angular extent than said insert rotatably accommodated therein, a rocker that is pivoted centrally proximate to said hollow having respective contoured ends, which oscillate  
15 between a first configuration for detachable interlocking of a first end within a respective first receptacle of the edge of said hollow and a second configuration for detachable interlocking of a second end within a respective second receptacle that is opposite the first one, at least one portion of said carousel and at least one portion of said insert being mated  
20 by respective elastic means, said insert abutting against at least one of said first and second ends in one of the first configuration and the second configuration, with consequent partially rotated arrangement of said insert and of the at least one portion of said carousel which is integral therewith.

Further characteristics and advantages of the invention will become  
25 more apparent from the description of a preferred but not exclusive embodiment of the non-handed handle assembly and of the corresponding selection apparatus according to the invention, illustrated by way of non-limiting example in the accompanying drawings, wherein:

Figure 1 is a perspective view of a non-handed handle assembly  
30 according to the invention;

Figure 2 is a front view of a non-handed handle assembly according to the invention;

Figure 3 is a front view of a non-handed handle assembly according to the invention;

5 Figure 4 is a front view of a non-handed handle assembly according to the invention;

Figure 5 is a perspective view of a component of a non-handed handle assembly according to the invention;

10 Figure 6 is a perspective view of an additional component of a non-handed handle assembly according to the invention.

With particular reference to the figures cited above, the numeral 1 generally designates a non-handed handle assembly and the numeral 2 designates a corresponding selection apparatus.

15 The handle assembly 1 comprises a main body 3 for the rotatable accommodation of a carousel 4, which is provided with a substantially central seat 5 for accommodating the transverse stem 6 of a handle.

The main body 3 has a substantially prismatic boxlike shape and is adapted to be accommodated within a dedicated compartment of the installation wing.

20 According to a preferred constructive solution, the main body 3 is substantially a parallelepiped that has a curved and convex face (the upper one in the installation configuration).

Elastic means 7 for contrasting the free rotation of the carousel 4 are interposed between the carousel 4 and the main body 3.

25 In practice, said elastic means 7 are referred to respective shoulders that prevent their free rotation: the rotation of the carousel 4 therefore occurs in contrast to said elastic means 7, which undergo an elastic deformation during said rotation movements (responding with a mechanical reaction of the elastic type).

30 The mechanical reaction of the elastic type is the one that will be

perceived by the user when he rotates the handle to cause the retraction of the spring latch and accordingly open the installation wing.

The main body 3 furthermore comprises a hollow 8 whose shape and dimensions are complementary to those of a contoured insert 9.

5 The hollow 8 and the contoured insert 9 have an annular shape in some of their portions: the entire extension of said annular portions is delimited by a specific contour angle (which defines the lateral space occupation).

The recess 8 has a greater angular extent (understood as its contour  
10 angle) than the insert 9 accommodated rotatably therein: in practice, therefore, the insert 9 can perform rotations (with respect to the rotation axis of the carousel 4 and of the stem 6 of the handle) of a small extent within the respective hollow 8.

A rocker 10 is pivoted centrally at a part of the hollow 8 and is  
15 provided with respective lateral contoured ends 11.

The ends 11, in the usage arrangement of the assembly 1, oscillate between a first configuration for detachable interlocking of a first end 11 within a respective first receptacle 12 of the edge 13 of the hollow 8 and a second configuration for detachable interlocking of a second end 11 within  
20 a respective second receptacle 12 that is opposite the first one.

In the movement between the first configuration and the second configuration, the rocker 10 can assume all the intermediate angular positions, in which, however, it is not constrained but can oscillate freely.

The insert 9 abuts against at least one of the first and second ends 11  
25 (in particular it abuts against the internal surface of the rocker 10 that lies opposite the contour of the end 11 intended to interlock in the respective receptacle 12) in either the first configuration or the second configuration, with a consequent partially rotated arrangement thereof.

When the insert 9 assumes a partially rotated configuration, in  
30 relation to the fact that the elastic means 7 use said insert 9 as a shoulder,

the carousel 4 also is kept by the elastic means 7 themselves in a partially rotated arrangement (when it is inactive and the elastic means 7 are not deformed).

This partial rotation of the carousel 4 also entails that the seat 5 for the stem 6 of the handle is rotated: the handle is therefore inclined (with respect to the horizontal) with a minimum height at the stem 6 and a maximum height at its free end (which is furthest from said stem 6).

This arrangement of the handle makes it more ergonomic and easily usable for the user.

Depending on the type of wing in which the handle assembly 1 is installed, it is possible to modify the partial rotation of the carousel 4 (moving the rocker 7 from the first configuration to the second configuration for interlocking one of its ends 11 in a receptacle 12) and therefore ensure that the handle assumes the ideal inclination in relation to ergonomics and convenience of use.

It is specified that the hollow 8 is substantially shaped like an annular sector that is symmetrical with respect to the longitudinal axis of the main body 3.

The hollow 8 is present (with different shapes and contours) in both of the mutually opposite faces of the main body 1 (bordering on the accommodation seat of the carousel 4): on a first face, its dimensions are greater in a radial direction and in the extent of the contour angle, and it has a shape that fully coincides with an annular sector; on the opposite face, its dimensions are smaller, since it is constituted by a T-shaped curved recess (the upper stem of the T-shape being shaped like an annular sector excavated within the body 3).

The constructive embodiment of greatest interest for the insert 9 comprises a base block 14 provided with two protruding lateral tabs 15.

The block 14 in turn is surmounted by a central post 16 that is provided with a perpendicular end band 17, which is integral with a

symmetrical curved frame 18 whose opposite heads 19 protrude laterally with respect to the lateral tabs 15 of the base block 14.

It is convenient to note that the curved frame 18 protrudes downward with respect to the perpendicular band 17: said protruding part is intended to  
5 be accommodated in the upper bar of the T-shaped recess that constitutes the hollow 8 in one of the two faces of the body 3.

The angular extent of the upper bar of the T-shaped recess that constitutes part of the hollow 8, as already shown previously, is greater than that of the curved frame 18, which can move (by rotating about the axis of  
10 the stem 6 of the handle) according to a predefined stroke.

The limits of said predefined stroke correspond to the two limiting configurations of the rocker 7 (first and second configuration, in which one end 11 is interlocked in a receptacle 12 of the edge 13). The edge 13 and therefore also the receptacle 12 and the rocker 10 are arranged in the portion  
15 of the hollow 8 that is located in the face that lies opposite the face provided with the T-shaped recess.

According to the constructive solution shown in the accompanying figures, a constructive solution that is of unquestionable interest in practice and in application, the rocker 10 comprises a central block 20 provided with  
20 a pivoting axis 21.

Said pivoting axis 21 is intended to be accommodated within a respective hole 22 of the main body 3.

The central block 20 is provided with two protruding symmetrical arms 23, which terminate respectively in the first end 11 and in the second  
25 end 11.

The carousel 4 comprises a shell 24 with a concavity that is complementary to a disk 25 for the corresponding accommodation.

The shell 24 is provided with a protruding perimetric pillar 26, while the disk 25 comprises a protruding perimetric bar 27.

30 The pillar 26 and the bar 27 are mutually parallel (and are furthermore



parallel to the axis of the stem 6).

When the handle assembly 1 is in the configuration for use, the pillar 26 and the bar 27 are substantially aligned and proximate.

In this configuration, the pillar 26 and the bar 27 are interposed  
5 between respective end protrusions 28 of elastic means 7, being forced elastically by them into mutual alignment.

It is specified that the elastic means 7 are constituted by a spiral spring that is substantially coaxial with the carousel 4 and has a diameter that is smaller than and proximate to the diameter of the accommodation for  
10 said carousel 4 of the main body 3.

The spring (which constitutes the elastic means 7) comprises the respective radial end protrusions 28 that are directed outward.

The central post 16 of the insert 9, the pillar 26 of the shell 24 and the bar 27 of the disk 25 are arranged between said protrusions 28 and are  
15 forced elastically into mutual alignment.

The shell 24 is functionally associated with the spring latch of the lock installed in the wing in which the handle assembly 1 is fitted. External devices are used which can be operated by an authorized user and are suitable for the selective locking/release of the shell 24: when the shell 24 is  
20 in the locking configuration, it is prevented from performing any rotation and it cannot cause the retraction of the spring latch; a rotation of the handle causes only a rotation of the disk 25 and does not allow the retraction the spring latch.

When the shell 24 is in the released configuration, by rotating the  
25 handle one rotates the disk 25 (which accommodates the stem 6 in its seat 5) together with the shell 24, which can thus cause the retraction of the spring latch and allow the opening of the installation wing.

It is deemed necessary to specify again that the shell 24 is integral, also with the interposition of respective transmission elements, with the  
30 spring latch of the lock of the wing in which the handle assembly 1 is

installed: these transmission elements are of a known type and therefore are not within the scope of the present invention.

The protective scope of the present invention also extends to a selection apparatus 2 for handle assemblies 1 that comprises a carousel 4 that can rotate within a seat 3a of a main body 3 provided with a hollow 8 whose shape and dimensions are complementary to those of a contoured insert 9.

The hollow 8 has a larger angular extent than the insert 9 accommodated rotatably therein.

10 A rocker 10 is pivoted, centrally proximate to the hollow 8, to the main body 2 and has respective contoured ends 11 that oscillate between a first configuration for detachable interlocking of a first end 11 within a respective first receptacle 12 of the edge 13 of the hollow 8 and a second configuration for detachable interlocking of a second end 11 within a  
15 respective second receptacle 12 that is opposite the first one.

At least one portion of the carousel 4 and at least one portion of the insert 9 are coupled by means of respective elastic means 7.

The insert 9 abuts against at least one of the first and second ends 11 in one of the first and second configurations, with consequent partially  
20 rotated arrangement of said insert 9 and of the at least one portion of the carousel 4 that is integral therewith.

The carousel 4 comprises a shell 24 whose concavity is complementary to a disk 25 for the corresponding seat.

The shell 24 is provided with a protruding perimetric pillar 26, while  
25 the disk 25 comprises a protruding perimetric bar 27.

In the configuration for use, the pillar 26 and the bar 27 are substantially aligned and proximate and interposed, together with at least one portion of the insert 9, between respective end protrusions 28 of the elastic means 7 and are forced elastically by them into mutual alignment.

30 It is deemed appropriate to specify that each edge 13 of the hollow 8

comprises two protruding teeth 29 that delimit a respective receptacle 12: each tooth 29 has an external face that is inclined for the guiding and conveyance of the respective end 11 of the rocker 10 (which slides on said inclined face before engaging, following an elastic deformation, in the  
5 respective receptacle 12).

The shell 24, according to a constructive solution of unquestionable interest in practice and in application, is integral, also with the interposition of respective transmission elements, with a spring latch of the lock of the wing in which the handle assembly 1 is installed.

10 Advantageously, the present invention solves the problems described earlier, proposing a non-handed handle assembly 1 that can be installed equally on doors with right-swing or left-swing opening, allowing comfortable use of the handle by the user.

Indeed, depending on the type of installation, it is possible to adjust  
15 the inclination of the handle in the inactive configuration simply by arranging within the respective receptacle 12 one end 11 or the other of the rocker 10.

Validly, the handle assembly 1 allows the installation of the handle, on doors equally with right-swing and left-swing opening, according to  
20 standardized position and inclination criteria: installation is in fact straightforward and, without the need for further modifications or calibrations, provides for the correct inclination of the handle in order to meet the current norms in terms of ergonomics.

Positively, the selection apparatus 2 makes a handle assembly 1 that  
25 comprises it suitable for use both on doors with right-swing or with left-swing opening.

Conveniently, the selection apparatus 2 according to the invention makes it possible to configure a handle assembly 1 that comprises it according to the two different installation possibilities, indicated for doors  
30 with right-swing and left-swing opening, repeating this configuration even

multiple times: thanks to the apparatus 1, therefore, the handle assembly can be disassembled from one door and installed on another door that has the opposite opening direction, simply by modifying the configuration of the rocker 10. It is unquestionable, therefore, that the handle assembly 1 that  
5 comprises the apparatus 2 is much more versatile than those of the known type.

Advantageously, the non-handed handle assembly 1 and the corresponding selection apparatus 2 have low costs and are relatively simple to provide and safe in application.

10 The invention thus conceived is susceptible of numerous modifications and variations, all of which are within the scope of the appended claims; all the details may furthermore be replaced with other technically equivalent elements.

In particular, it is specified that the orientation of the seat 5 is such as  
15 to eliminate the effects of any machining tolerances of the stem 6 of the handle, which might cause a downward-oriented arrangement thereof, if a precise coupling between the seat 5 and the stem 6 does not occur.

In the exemplary embodiments shown, individual characteristics, given in relation to specific examples, may actually be interchanged with  
20 other different characteristics that exist in other exemplary embodiments.

In practice, the materials used, as well as the dimensions, may be any according to the requirements and the state of the art.

Where technical features mentioned in any claim are followed by reference signs, those reference signs have been included for the sole  
25 purpose of increasing the intelligibility of the claims and accordingly such reference signs do not have any limiting effect on the interpretation of each element identified by way of example by such reference signs.

CLAIMS

1. A non-handed handle assembly of the type comprising a main body (3) for rotatable accommodation of a carousel (4), provided with a substantially central seat (5) for the accommodation of the transverse stem (6) of a handle, elastic means (7) for contrasting the free rotation of said carousel (4) being interposed between said carousel (4) and said main body (3), characterized in that said body (3) comprises a hollow (8) whose shape and dimensions are complementary to those of a contoured insert (9), said hollow (8) having a larger angular extent than said insert (9) rotatably accommodated therein, a rocker (10) that is pivoted centrally proximate to said hollow (8) having respective contoured ends (11), which oscillate between a first configuration for detachable interlocking of a first end (11) within a respective first receptacle (12) of the edge (13) of said hollow (8) and a second configuration for detachable interlocking of a second end (11) within a respective second receptacle (12) that is opposite the first one, said insert (9) abutting against at least one of said first end and said second end (11) in one of the first configuration and the second configuration, with consequent partially rotated arrangement thereof.

2. The non-handed handle assembly according to claim 1, characterized in that said hollow (8) is substantially shaped like an annular sector, which is symmetrical with respect to the longitudinal axis of said main body (3) on one side of said body (3), on the opposite side said hollow (8) being constituted by a curved T-shaped recess.

3. The non-handed handle assembly according to claim 1, characterized in that said insert (9) comprises a base block (14), provided with two protruding lateral tabs (15), a block (14) surmounted by a central post (16) provided with a perpendicular end band (17), integral with a symmetrical curved frame (18) in which the mutually opposite heads (19) protrude laterally with respect to said lateral tabs (15) of said base block (14).

4. The non-handed handle assembly according to claim 1, characterized in that said rocker (10) comprises a central block (20) provided with an axis (21) for pivoting to a respective hole (22) of said main body (3), said block (20) being provided with two protruding  
5 symmetrical arms (23) that terminate respectively in said first end (11) and in said second end (11).

5. The non-handed handle assembly according to claim 1, characterized in that said carousel (4) comprises a shell (24) with a concavity that is complementary to a disk (25) for the corresponding seat,  
10 said shell (24) being provided with a protruding perimetric pillar (26), said disk (25) comprising a protruding perimetric bar (27), in the configuration for use said pillar (26) and said bar (27) being substantially aligned and proximate and interposed between respective end protrusions (28) of said elastic means (7) and being forced elastically by them into mutual  
15 alignment.

6. The non-handed handle assembly according to one or more of the preceding claims, characterized in that said elastic means (7) are constituted by a spiral spring that is substantially coaxial with said carousel (4) and has a diameter that is smaller than and proximate to the diameter of the seat (3a)  
20 of the main body (3) for said carousel (4), said spring comprising respective radial end protrusions (28) that are directed outward, said central post (16) of said insert (9), said pillar (26) of said shell (24) and said bar (27) of said disk (25) being arranged and forced elastically into mutual alignment between said protrusions (28).

25 7. The non-handed handle assembly according to one or more of the preceding claims, characterized in that said shell (24) is integral, also with the interposition of respective transmission elements, with a spring latch of the lock of the wing in which the handle assembly (1) is installed, said disk (25) comprising a seat (5) for the accommodation of the stem (6) of a  
30 respective actuation handle.

8. A selection apparatus for handle assemblies (1), characterized in that it comprises a carousel (4) that can rotate within a seat (3a) of a main body (3) provided with a hollow (8) whose shape and dimensions are complementary to those of a contoured insert (9), said hollow (8) having a larger angular extent than said insert (9) rotatably accommodated therein, a rocker (10) that is pivoted centrally proximate to said hollow (8) having respective contoured ends (11), which oscillate between a first configuration for detachable interlocking of a first end (11) within a respective first receptacle (12) of the edge (13) of said hollow (8) and a second configuration for detachable interlocking of a second end (11) within a respective second receptacle (12) that is opposite the first one, at least one portion of said carousel (4) and at least one portion of said insert (9) being mated by respective elastic means (7), said insert (9) abutting against at least one of said first and second ends (11) in one of the first configuration and the second configuration, with consequent partially rotated arrangement of said insert (9) and of the at least one portion of said carousel (4) integral therewith.

9. The selection apparatus according to the preceding claim, characterized in that said carousel (4) comprises a shell (24) with a concavity that is complementary to a disk (25) for the corresponding seat, said shell (24) being provided with a protruding perimetric pillar (26), said disk (25) comprising a protruding perimetric bar (27), in the configuration for use said pillar (26) and said bar (27) being substantially aligned and proximate and interposed, together with at least one portion of said insert (9), between respective end protrusions (28) of said elastic means (7) and being forced by them elastically into mutual alignment.

10. The selection apparatus according to claim 8, characterized in that each edge (13) of said hollow (8) comprises two protruding teeth (29) that delimit a respective receptacle (12), each tooth (29) having an outer face that is inclined for the guiding and conveyance of the respective end of said

rocker (10).

11. The selection apparatus according to claim 8, characterized in that said shell (24) is integral, also with the interposition of respective transmission elements, with a spring latch of the lock of the wing in which  
5 the handle assembly (1) is installed, said disk (25) comprising an accommodation seat (5) for the stem (6) of a respective actuation handle.



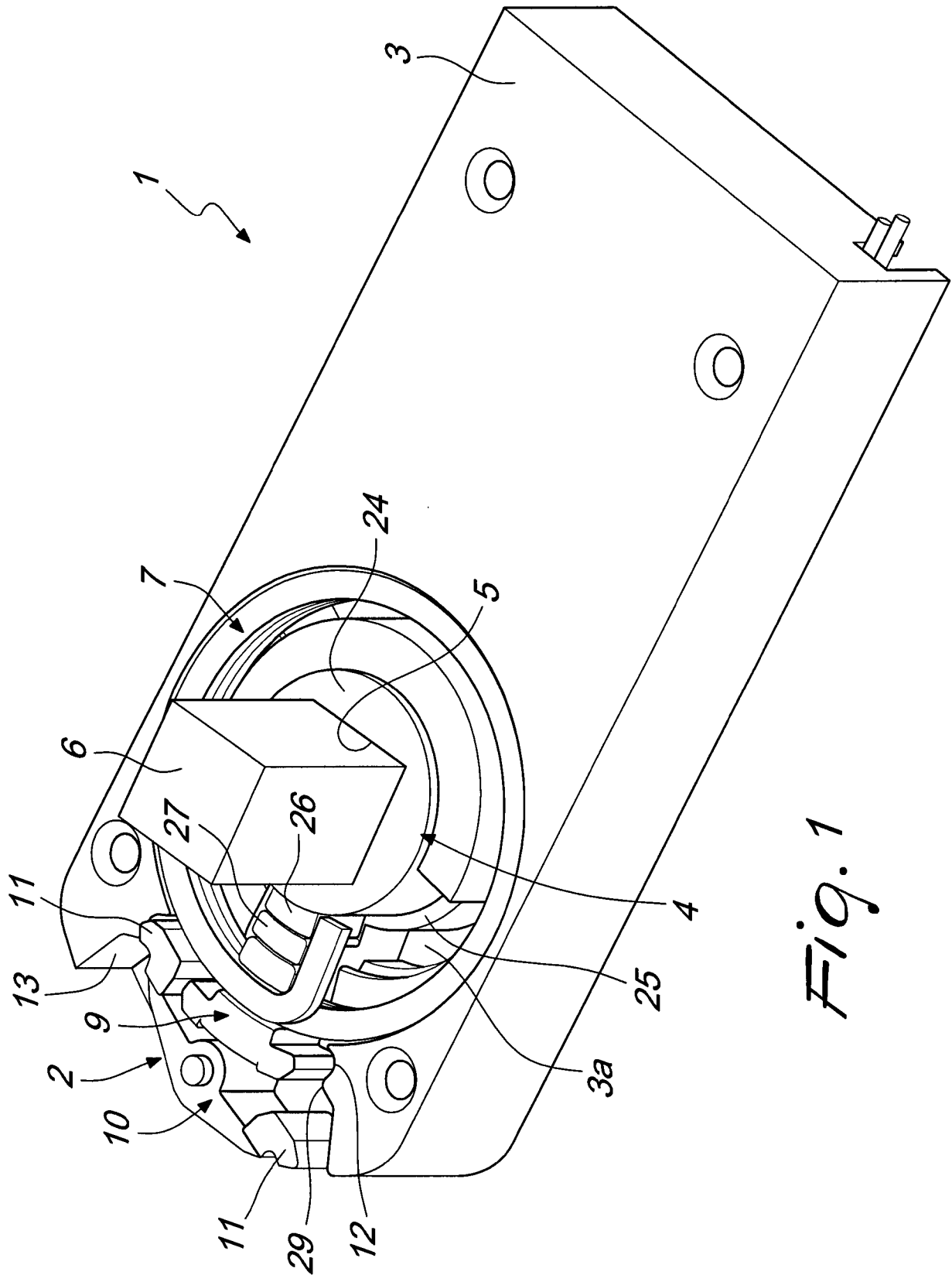

Fig. 1

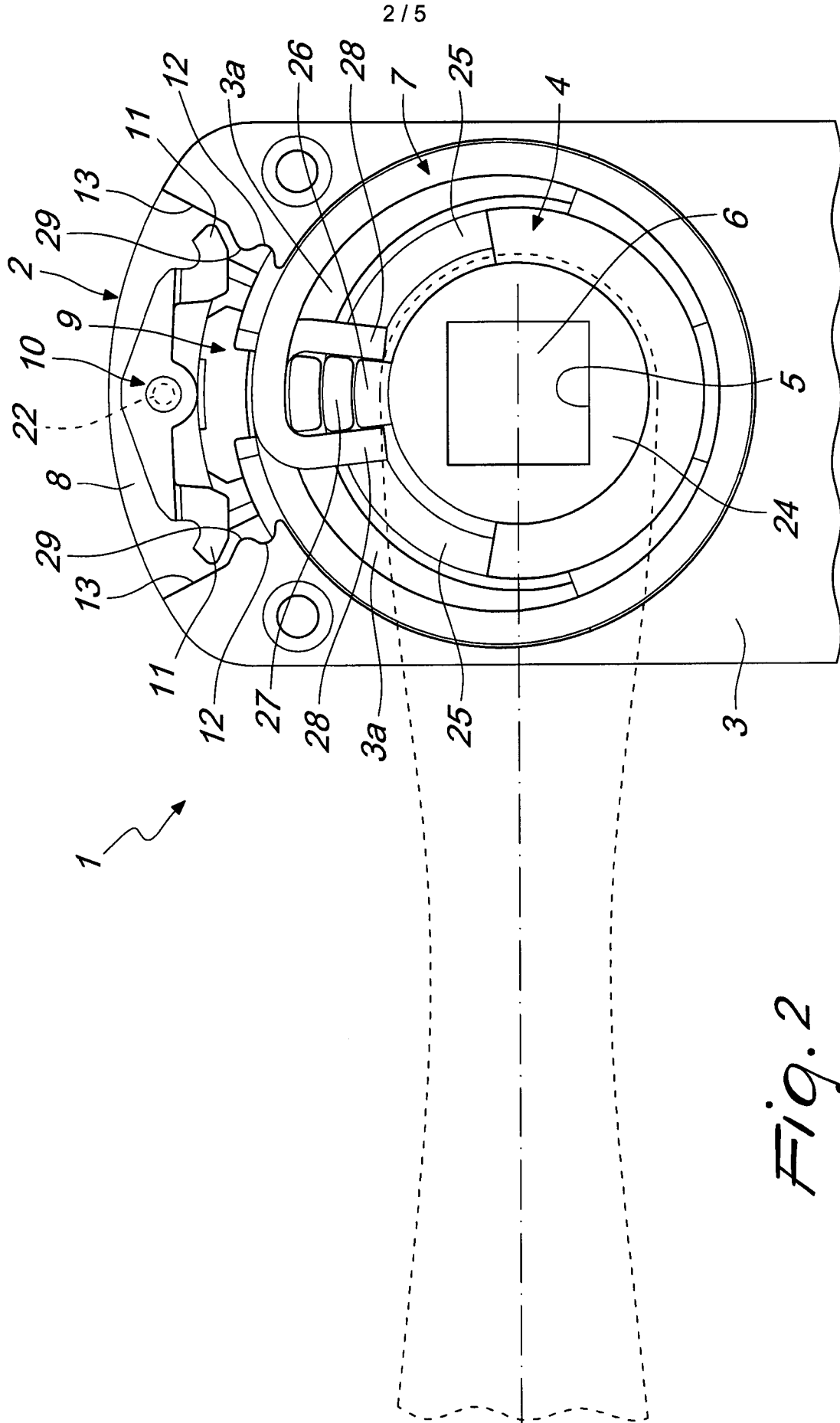

Fig. 2

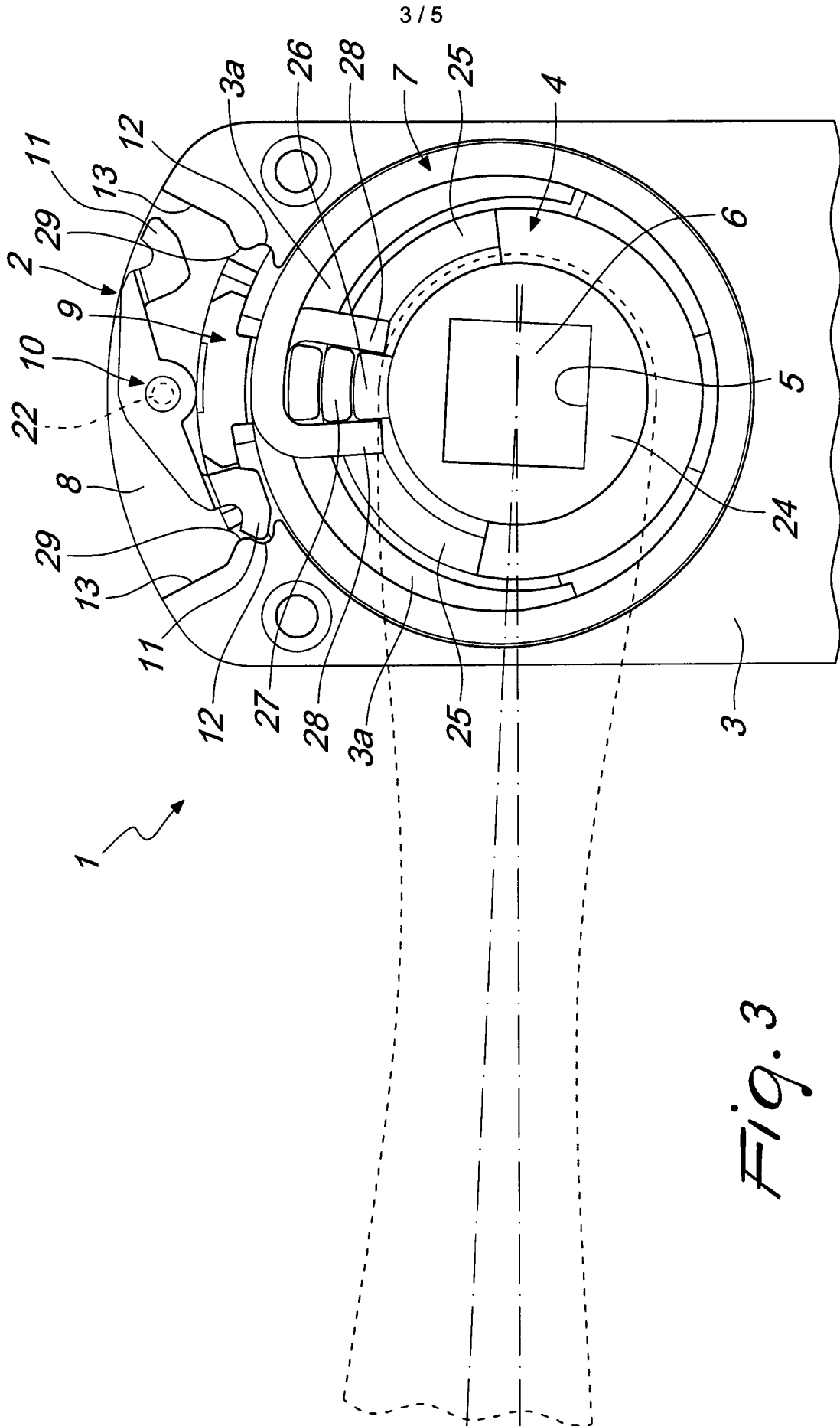

Fig. 3

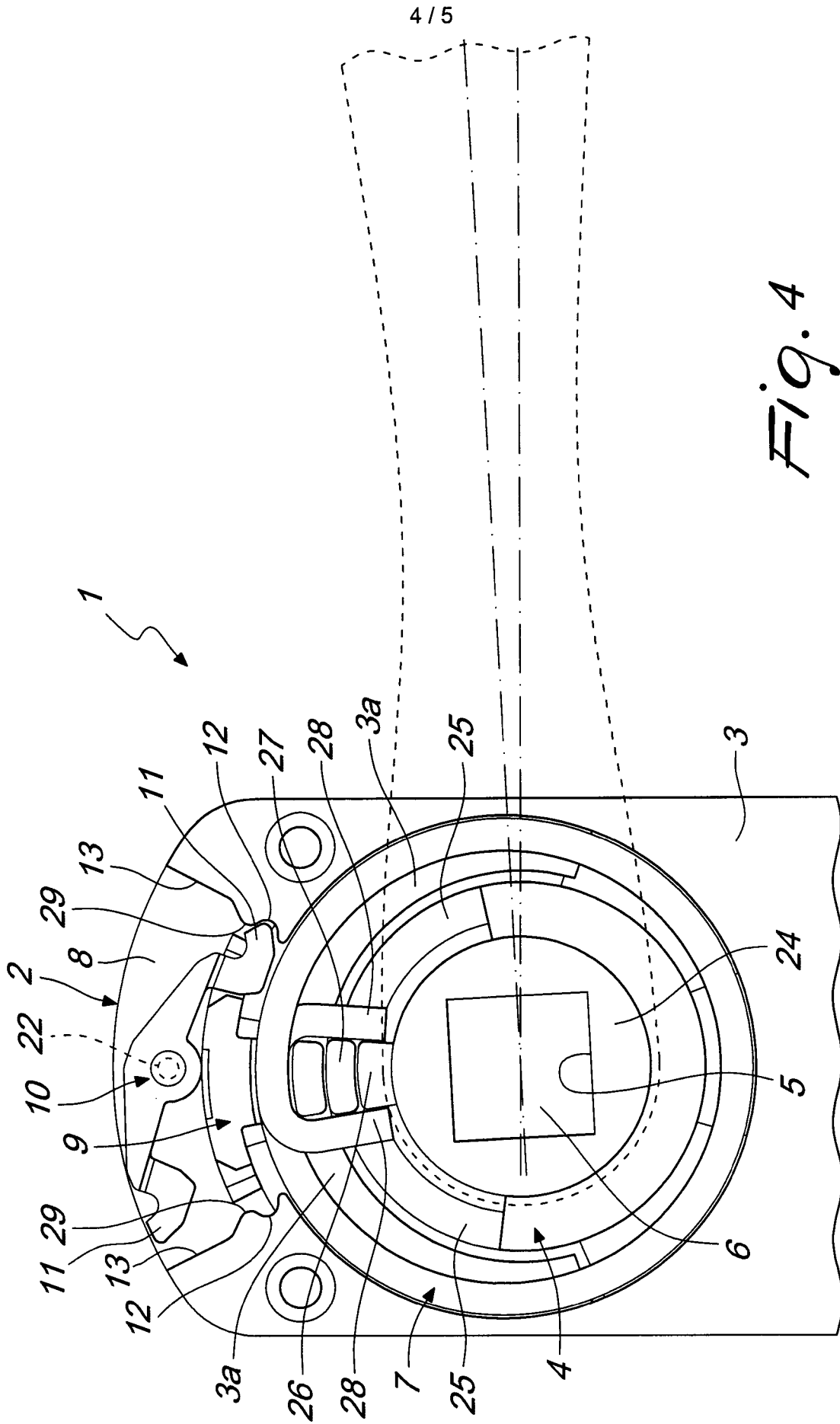

Fig. 4

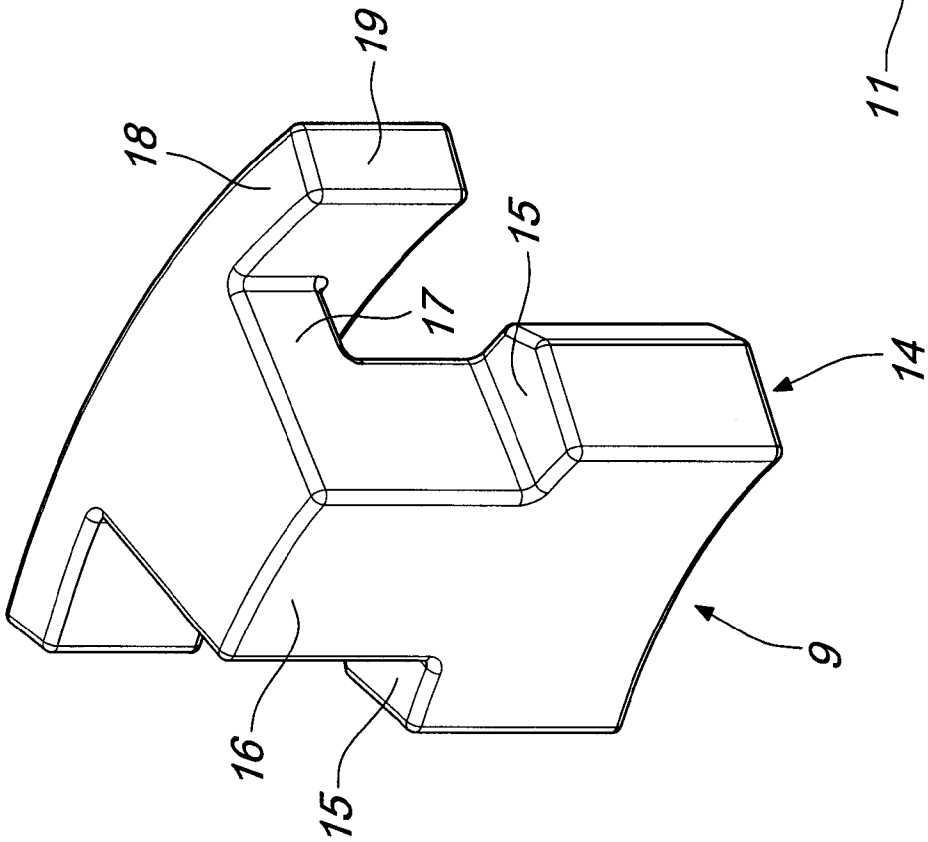

Fig. 5

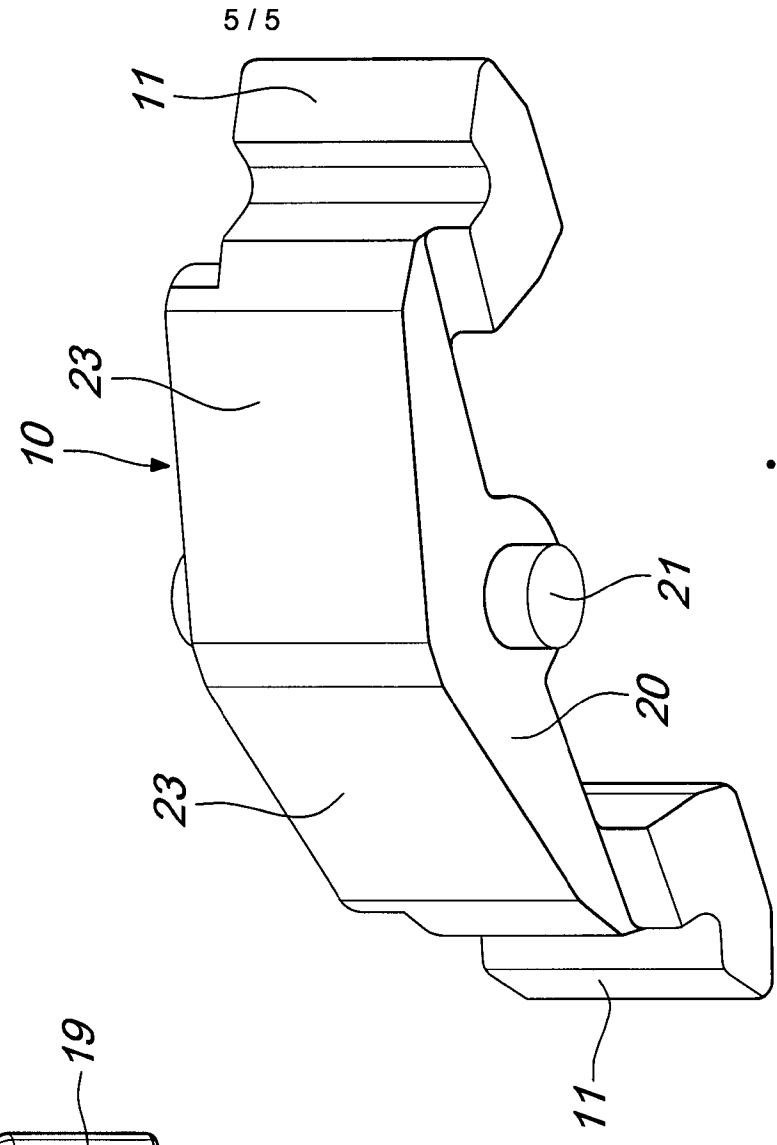

Fig. 6

INTERNATIONAL SEARCH REPORT

International application No  
PCT/IT2013/000360

A. CLASSIFICATION OF SUBJECT MATTER  
INV. E05B3/06  
ADD. E05B63/04

According to International Patent Classification (IPC) or to both national classification and IPC

B. FIELDS SEARCHED

Minimum documentation searched (classification system followed by classification symbols)  
E05B

Documentation searched other than minimum documentation to the extent that such documents are included in the fields searched

Electronic data base consulted during the international search (name of data base and, where practicable, search terms used)  
EPO-Internal

C. DOCUMENTS CONSIDERED TO BE RELEVANT

Category*	Citation of document, with indication, where appropriate, of the relevant passages	Relevant to claim No.
A	AT 9 593 U1 (KABA GMBH [AT]) 15 December 2007 (2007-12-15) page 2, line 4 - line 7; figure 2 page 2, line 18 - line 21 page 2, line 43 - line 49 page 3, line 29 - line 35	1-11
A	DE 20 2010 005648 U1 (DOM SICHERHEITSTECHNIK [DE]) 14 October 2011 (2011-10-14) figures 2-6, 11	1-11
A	EP 2 397 627 A2 (DOM SICHERHEITSTECHNIK [DE]) 21 December 2011 (2011-12-21) figures 14-16	1-11
	----- -/--	

Further documents are listed in the continuation of Box C.

See patent family annex.

\* Special categories of cited documents :

"A" document defining the general state of the art which is not considered to be of particular relevance

"E" earlier application or patent but published on or after the international filing date

"L" document which may throw doubts on priority claim(s) or which is cited to establish the publication date of another citation or other special reason (as specified)

"O" document referring to an oral disclosure, use, exhibition or other means

"P" document published prior to the international filing date but later than the priority date claimed

"T" later document published after the international filing date or priority date and not in conflict with the application but cited to understand the principle or theory underlying the invention

"X" document of particular relevance; the claimed invention cannot be considered novel or cannot be considered to involve an inventive step when the document is taken alone

"Y" document of particular relevance; the claimed invention cannot be considered to involve an inventive step when the document is combined with one or more other such documents, such combination being obvious to a person skilled in the art

"&" document member of the same patent family

Date of the actual completion of the international search  12 September 2014	Date of mailing of the international search report  22/09/2014
--	--

Name and mailing address of the ISA/ European Patent Office, P.B. 5818 Patentlaan 2 NL - 2280 HV Rijswijk Tel. (+31-70) 340-2040, Fax: (+31-70) 340-3016	Authorized officer  Philipp, Tobias
--	---

## INTERNATIONAL SEARCH REPORT

International application No  
PCT/IT2013/000360

C(Continuation). DOCUMENTS CONSIDERED TO BE RELEVANT		
Category*	Citation of document, with indication, where appropriate, of the relevant passages	Relevant to claim No.
A	EP 2 273 041 A1 (FERREMI LEONINO S R L [IT]) 12 January 2011 (2011-01-12) figures 2a - 2b -----	1-11
A	DE 20 2013 103127 U1 (ASTRA GES FUER ASSET MAN MBH [DE]) 8 August 2013 (2013-08-08) figures 2,3 -----	1-11

# INTERNATIONAL SEARCH REPORT

Information on patent family members

International application No

PCT/IT2013/000360

Patent document cited in search report	Publication date	Patent family member(s)	Publication date
AT 9593	U1	15-12-2007	AT 9593 U1
			EP 1930530 A2
			15-12-2007
			11-06-2008
-----			
DE 202010005648	U1	14-10-2011	NONE
-----			
EP 2397627	A2	21-12-2011	DE 102010017388 A1
			EP 2397627 A2
			12-01-2012
			21-12-2011
-----			
EP 2273041	A1	12-01-2011	NONE
-----			
DE 202013103127	U1	08-08-2013	NONE
-----			