



US 20170285265A1

(19) **United States**

(12) **Patent Application Publication**
Chen

(10) **Pub. No.: US 2017/0285265 A1**

(43) **Pub. Date: Oct. 5, 2017**

(54) **FACET OPTICAL COUPLER**

Publication Classification

(71) Applicant: **Acacia Communications, Inc.**,
Maynard, MA (US)

(51) **Int. Cl.**
G02B 6/122 (2006.01)
G02B 6/24 (2006.01)
G02B 6/14 (2006.01)

(72) Inventor: **Long Chen**, Marlboro, NJ (US)

(52) **U.S. Cl.**
CPC **G02B 6/1228** (2013.01); **G02B 6/14**
(2013.01); **G02B 6/24** (2013.01); **G02B**
2006/12097 (2013.01)

(73) Assignee: **Acacia Communications, Inc.**,
Maynard, MA (US)

(57) **ABSTRACT**

(21) Appl. No.: **15/620,601**

Techniques for forming a facet optical coupler to couple light at an edge of silicon substrate are described. The facet optical coupler includes a silicon substrate, a layer of second material disposed on the silicon substrate and in direct contact with the edge of the silicon substrate, and an undercut region disposed between a portion of the silicon substrate and the layer of second material. The undercut region is offset from the edge to provide mechanical integrity of the facet optical coupler to improve production of photonic integrated circuits having the facet optical coupler from a wafer.

(22) Filed: **Jun. 12, 2017**

Related U.S. Application Data

(63) Continuation of application No. 14/796,678, filed on Jul. 10, 2015, now Pat. No. 9,703,038.

(60) Provisional application No. 62/023,529, filed on Jul. 11, 2014.

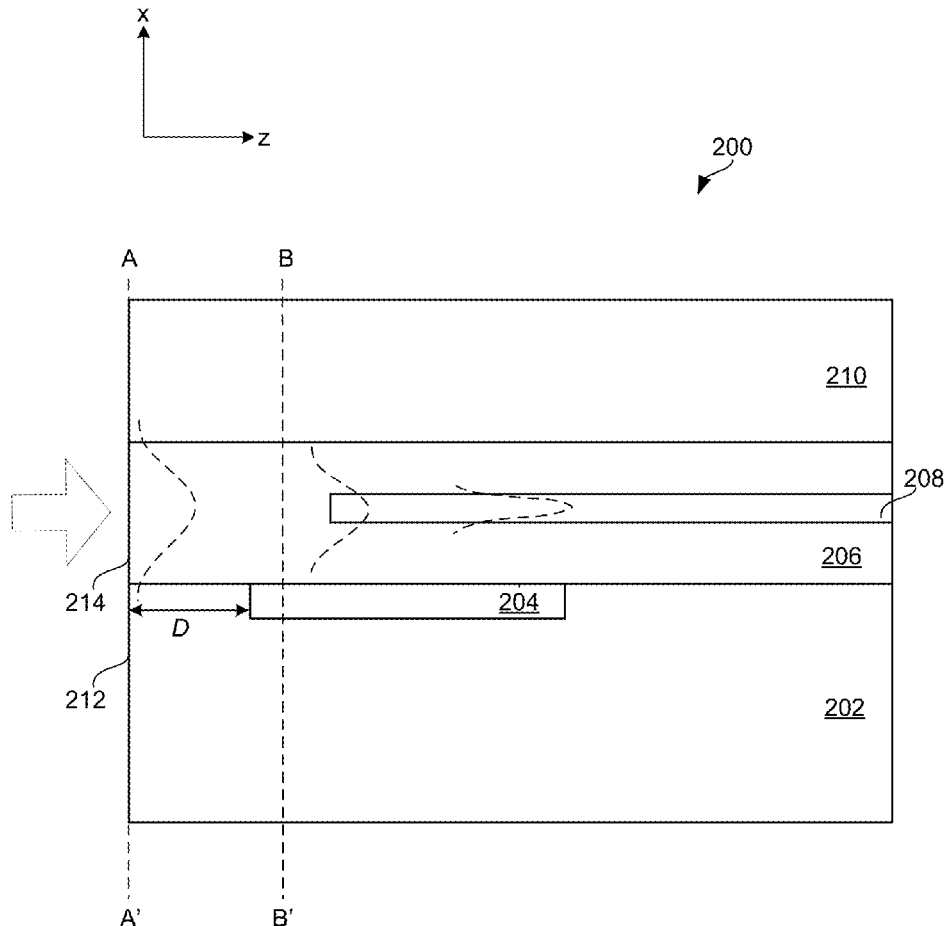

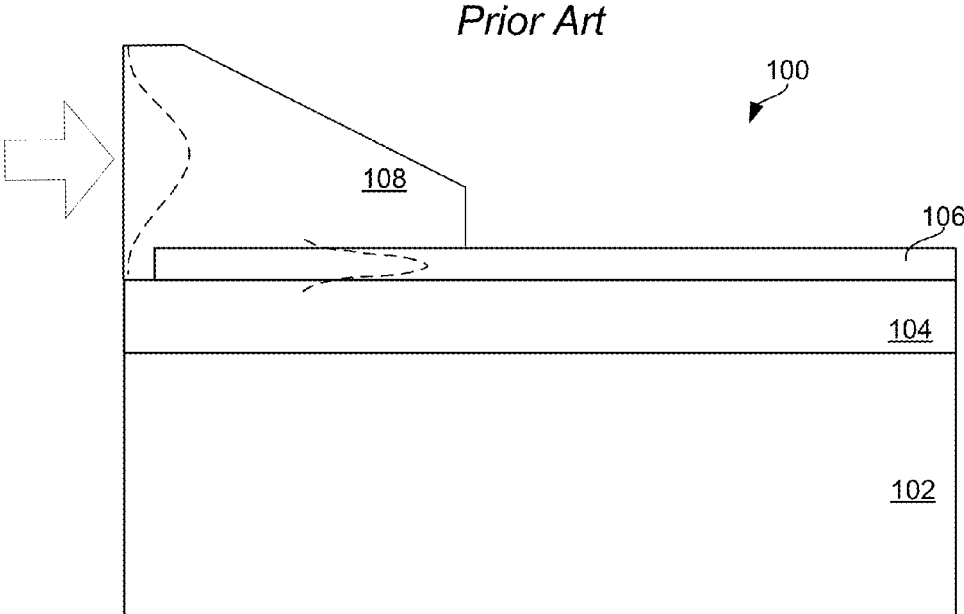

FIG. 1A

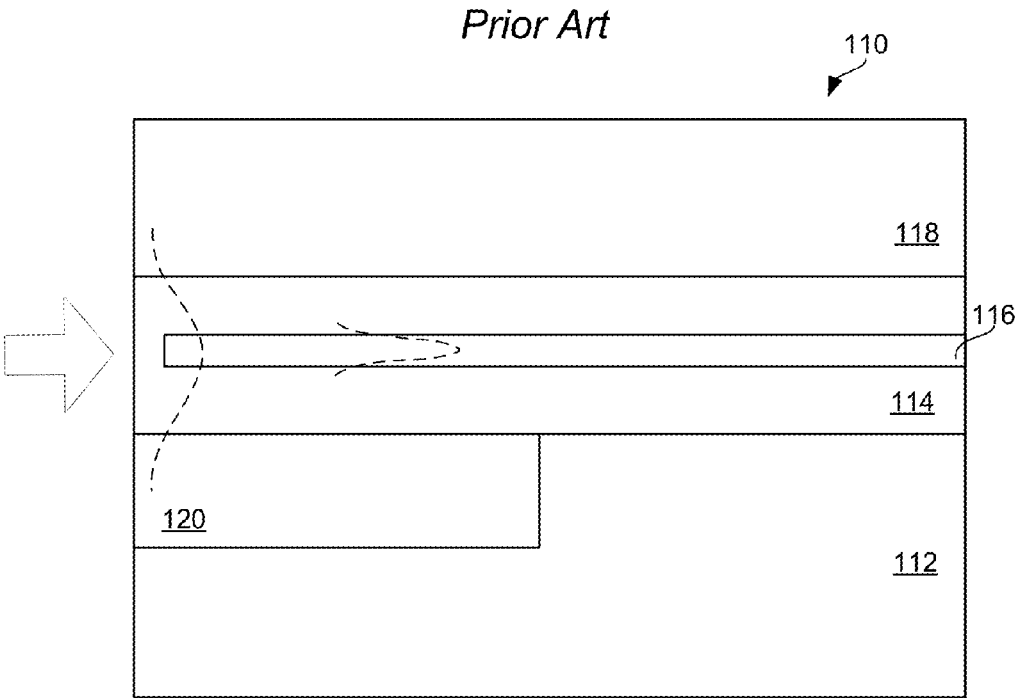
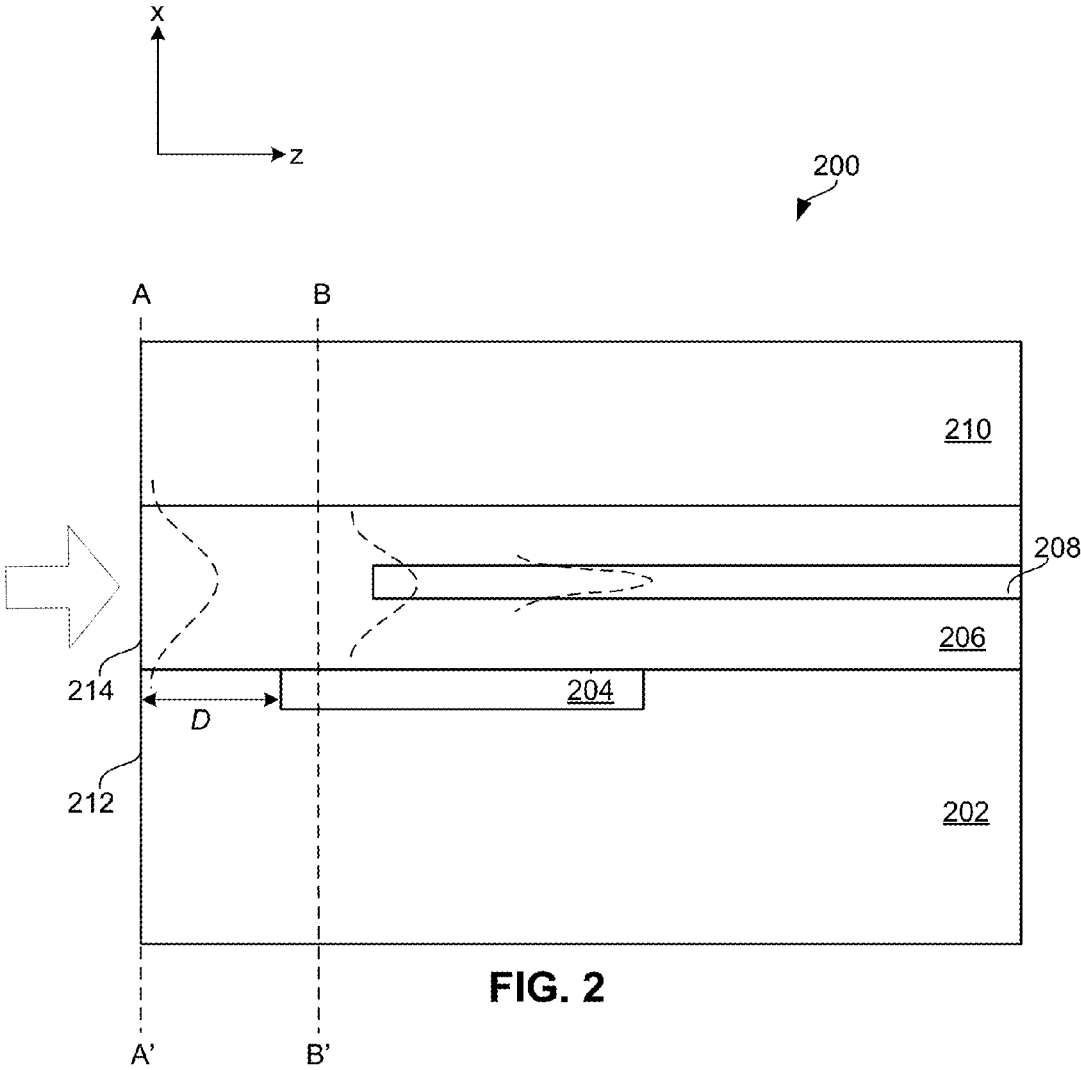

FIG. 1B



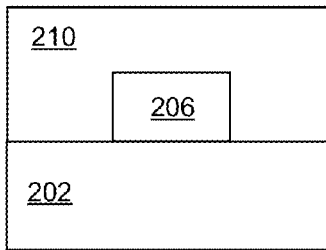
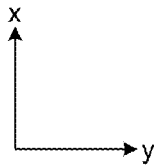

FIG. 3A

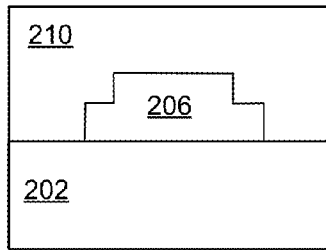

FIG. 3B

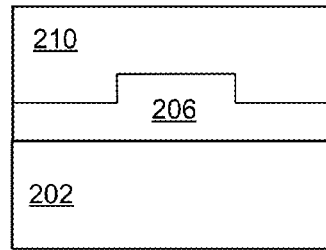

FIG. 3C

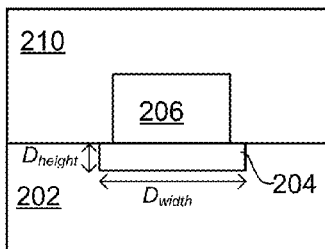

FIG. 4A

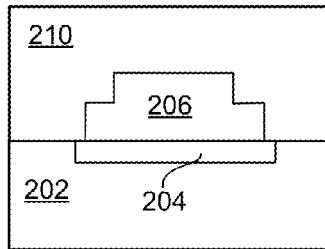

FIG. 4B

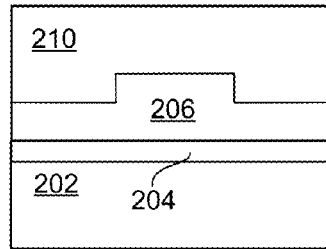

FIG. 4C

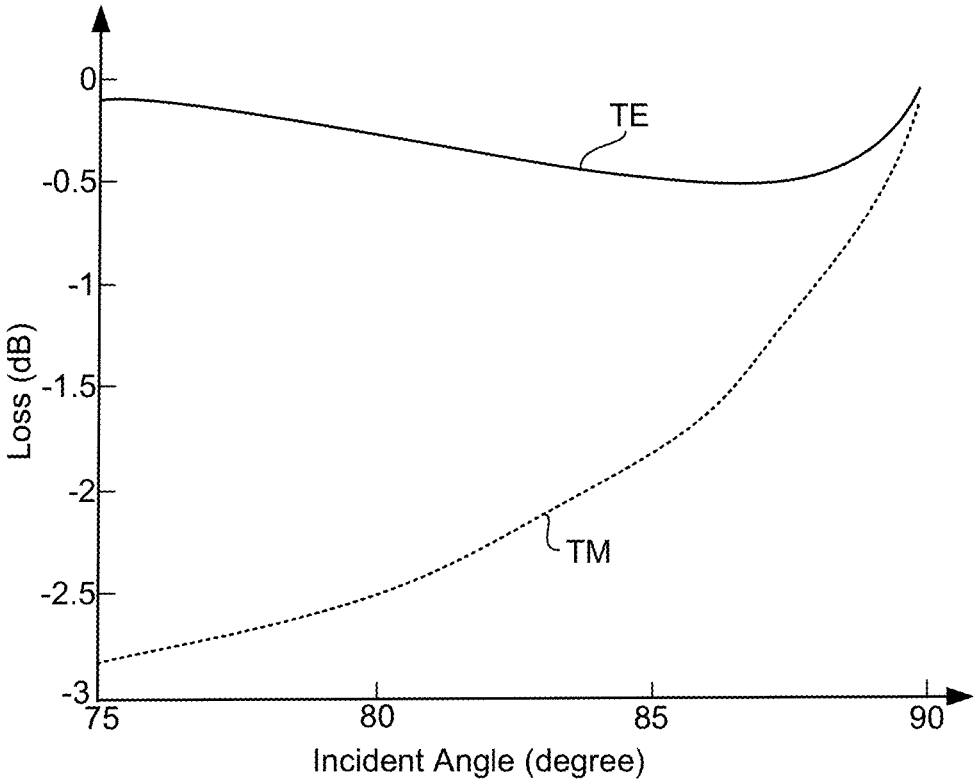

FIG. 5

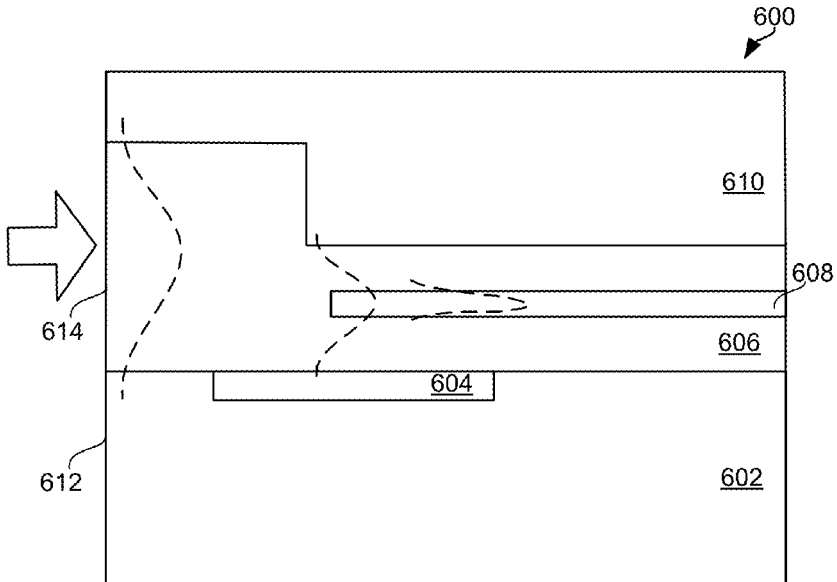
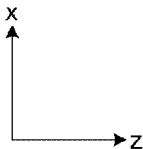

FIG. 6

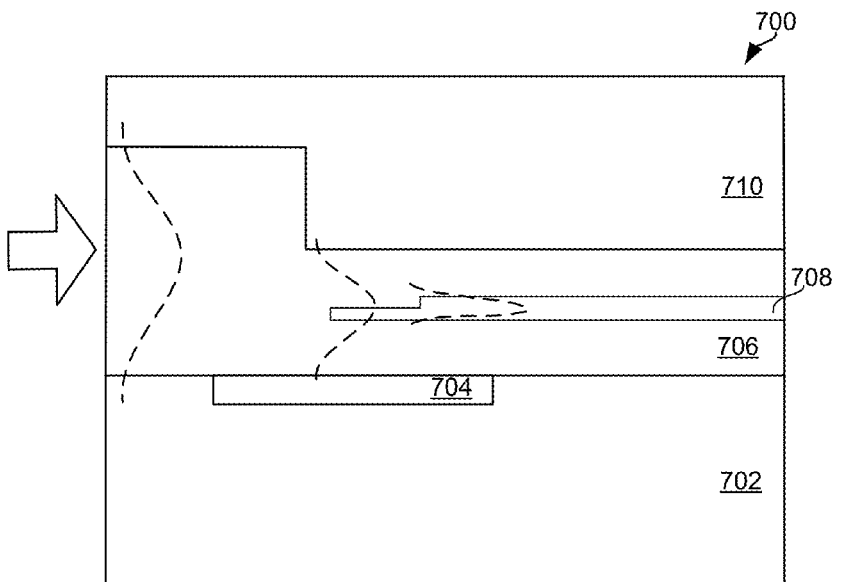

FIG. 7

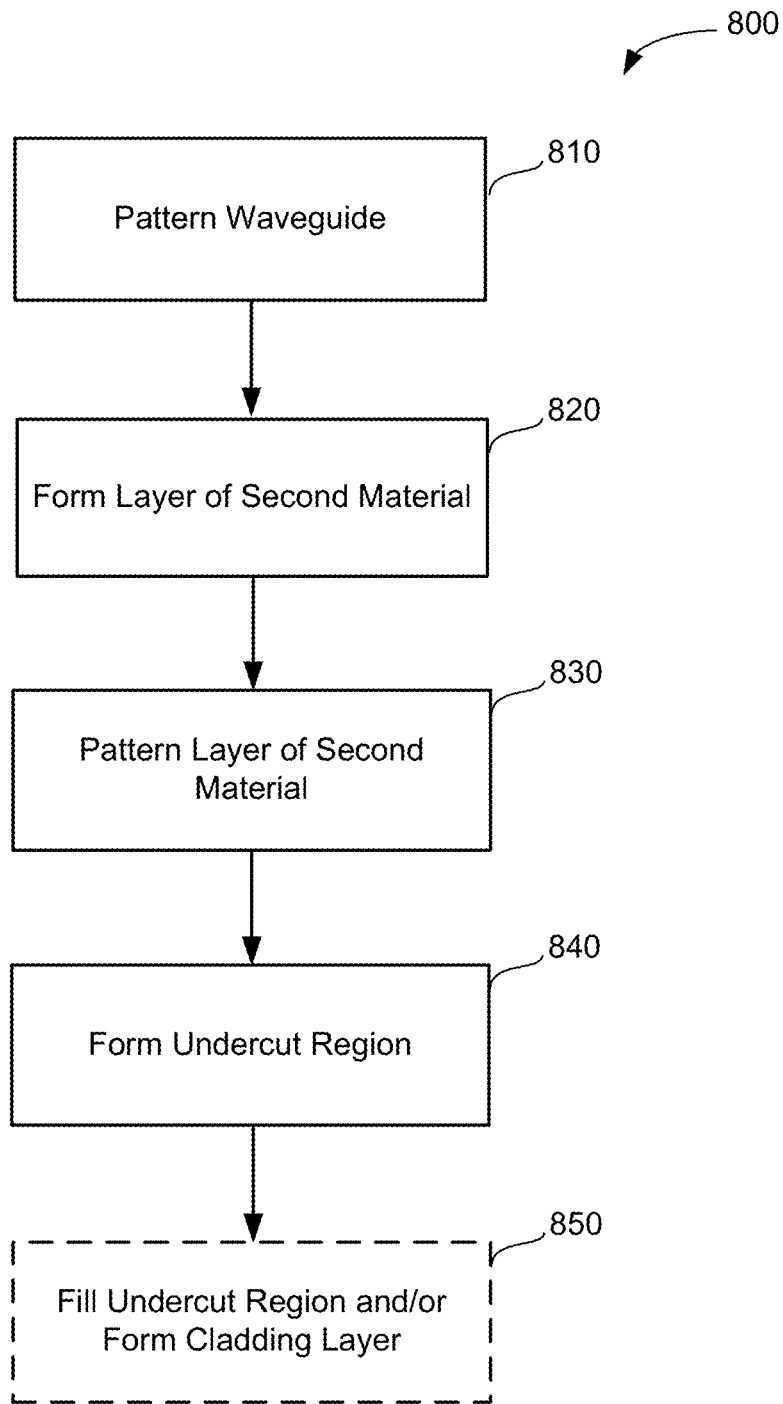

FIG. 8

FACET OPTICAL COUPLER

RELATED APPLICATIONS

[0001] The present application claims the benefit under 35 U.S.C. §120 of U.S. application Ser. No. 14/796,678, filed on Jul. 10, 2015 under Attorney Docket No. A1117.70007US01 and entitled “FACET OPTICAL COUPLER,” which is hereby incorporated herein by reference in its entirety. Application Ser. No. 14/796,678 claims the benefit under 35 U.S.C. §119(e) of U.S. Provisional Patent Application Ser. No. 62/023,529 entitled “FACET OPTICAL COUPLER,” filed Jul. 11, 2014, which is incorporated herein by reference in its entirety.

BACKGROUND

Field

[0002] The present application relates to a facet optical coupler and related apparatus and methods.

Related Art

[0003] A photonic integrated circuit (PIC) includes integrated optical components on a substrate. A facet optical coupler couples an external optical component, such as an optical fiber, to a waveguide of the PIC via an edge of the substrate.

BRIEF SUMMARY

[0004] According to an aspect of the present application a facet optical coupler is provided. The facet optical coupler comprises a silicon substrate having an edge, a waveguide, a layer of second material, and an undercut region. The layer of second material is disposed on the silicon substrate and in contact with the silicon substrate at the edge. The waveguide is embedded within the layer of second material. The undercut region is disposed between a portion of the silicon substrate and the layer of second material.

[0005] According to another aspect of the present application a method of manufacturing a facet optical coupler is provided. The method comprises forming, in a surface of a silicon substrate having a first index of refraction, a region having a second index of refraction less than the first index of refraction. The silicon substrate further comprises an edge. The method further comprises forming a layer of second material on the surface of the silicon substrate such that an edge of the layer of second material is substantially co-planar with the edge of the silicon substrate and forming a waveguide embedded in the layer of second material.

BRIEF DESCRIPTION OF DRAWINGS

[0006] Various aspects and embodiments of the application will be described with reference to the following figures. It should be appreciated that the figures are not necessarily drawn to scale. Items appearing in multiple figures are indicated by the same reference number in all the figures in which they appear.

[0007] FIGS. 1A and 1B are cross-sectional diagrams of examples of facet couplers.

[0008] FIG. 2 is a cross-sectional diagram of a facet coupler having an offset undercut region, according to a non-limiting embodiment.

[0009] FIGS. 3A-3C illustrate, in cross-sectional views, alternative examples of the facet coupler of FIG. 2 taken along line A-A' in FIG. 2.

[0010] FIGS. 4A-4C illustrate, in cross-sectional views, alternate examples of the facet coupler of FIG. 2 taken along line B-B' in FIG. 2.

[0011] FIG. 5 is a plot of power loss as a function of incident angle for polarizations TE and TM in a facet coupler of the type illustrated in FIG. 2.

[0012] FIG. 6 is a cross-sectional diagram of an example of a facet coupler according to a non-limiting embodiment.

[0013] FIG. 7 is a cross-sectional diagram of an example of a facet coupler according to a non-limiting embodiment.

[0014] FIG. 8 is a schematic illustrating an exemplary method for forming a facet coupler according to a non-limiting embodiment.

DETAILED DESCRIPTION

[0015] Aspects of the present application relate to a facet optical coupler of a silicon-based integrated device. The contrast in the indices of refraction between silicon and other materials (e.g., silicon dioxide, air) allows the formation of silicon-based photonic integrated circuits (PICs) with submicron waveguide dimensions. While PICs can include multiple components because of these submicron dimensions, coupling an optical fiber as an optical input or output to a submicron waveguide on the PIC can be challenging due to the mismatch in mode field size between the optical fiber and the waveguide. For example, a standard single-mode optical fiber has a mode field diameter of approximately 10 microns, while a silicon submicron waveguide has a mode field diameter of less than 1 micron. Direct coupling or butt coupling between the fiber and the waveguide may result in significant coupling loss, such as more than 20 dB in some instances. Thus, coupling techniques that account for the significantly different mode sizes between an optical fiber and a submicron silicon waveguide may improve performance of silicon based PICs by reducing coupling loss.

[0016] One type of coupling technique may include a grating coupler on an integrated device, where mode matching can be achieved by forming the dimensions of the waveguide and positioning additional elements to direct scattered light. Such couplers may have a narrow optical bandwidth because the capability to direct light between the fiber and the waveguide depends on the extent to which phase matching conditions are met. Another type of coupling technique may vary the dimensions and/or shape of the waveguide to improve mode matching by expanding the mode field of the waveguide in one or more dimensions to sufficiently couple with the mode field of the optical fiber. The waveguide may be tapered in one or more dimensions perpendicular to the direction of light propagation within the waveguide. However, challenges may arise in implementing these designs because of the index of refraction of the surrounding materials, including cladding materials and the silicon substrate. The large contrast in the indices of refraction between the silicon and cladding materials provides that the tapered waveguide has a narrow tip, such as 50 nm or less, to sufficiently expand the mode field. The silicon substrate may be located within 3 microns or less of the waveguide and may interfere with the mode field expansion of the waveguide due to this proximity.

[0017] Applicants have appreciated that incorporating a layer of second material in a facet optical coupler of a

photonic integrated circuit (PIC) may improve the coupling of light between an optical fiber and the PIC. The layer of second material may function as an auxiliary waveguide bridging the external coupling beam and the submicron silicon waveguide. Accordingly, aspects of the present application relate to a facet optical coupler with a layer of second material disposed on a silicon substrate and in direct contact with the silicon substrate. A waveguide of the integrated device may be embedded within the layer of second material. In some embodiments, the layer of second material and the silicon substrate may have coplanar edges.

[0018] A cross-sectional view of a facet optical coupler is shown in FIG. 1A. Facet optical coupler **100** includes silicon substrate **102**, layer **104**, silicon waveguide **106**, and overlay region **108**. The overlay region may act as a waveguide and may have a refractive index higher than that of layer **104**. Overlay region **108** may define the size and shape of the mode field. Overlay region **108** may include a taper, and the buried waveguide **106** may include a taper as well, both of which are to direct light coupled into overlay region **108** towards waveguide **106**, as shown by the dashed lines in FIG. 1A. The dimensions of overlay region **108** at the edge of the facet optical coupler (at the arrow shown in FIG. 1A) may constrain expansion of the mode and may lack suitable coupling for some optical fibers, such as optical fibers with a large mode field size (e.g., approximately 10 microns).

[0019] A cross-sectional view of another facet optical coupler is shown in FIG. 1B. Facet optical coupler **110** includes silicon substrate **112**, undercut region **120**, layer **114**, waveguide **116**, and cladding **118**. Undercut region **120** separates silicon substrate **112** from waveguide **116** near the facet, reducing interference in the mode field expansion during coupling of facet optical coupler **110** with an optical fiber. As shown by the dashed lines in FIG. 1B, the mode field expands near the edge of the integrated device and contracts in a direction of light propagation along waveguide **116**. Undercut region **120** may have a lower refractive index than that of both the layer **114** and silicon substrate **112**.

[0020] In some cases, undercut region **120** may be air, which results in layer of second material **114** being suspended over silicon substrate **112** at the edge. Having undercut region **120** located at an edge where layer **114** is suspended reduces the mechanical integrity of facet optical coupler **110**. This lack of structural integrity may be particularly problematic during formation of an integrated device having facet coupler **100** because the structure of the facet coupler may break or become faulty when a wafer is diced along edges of the integrated device and/or when adhering optical fibers to the edges of the device for packaging of the device.

[0021] Applicants have appreciated that offsetting the undercut region from an edge of a silicon substrate can result in suitable coupling performance even if there is a region where the silicon substrate forms an interface with a layer of second material. Accordingly, aspects of the present application relate to forming a facet optical coupler with an undercut region offset a distance from an edge of an integrated device. Such an undercut region may improve the mechanical integrity of the device by adhering a silicon substrate and a layer of second material at an edge of the integrated device. The distance by which the undercut region is offset from the edge may be selected to provide suitable coupling efficiency for the facet coupler while maintaining sufficient mechanical integrity. In this manner, a facet optical

coupler having an offset undercut region may facilitate production and processing of integrated devices having the facet optical coupler while providing desired coupling efficiency with an external optical component.

[0022] In some embodiments, the undercut region may be formed by removing a portion of the silicon substrate, and in some embodiments, filling the removed portion with a filler material having a lower index of refraction than the silicon substrate and the second material.

[0023] The aspects and embodiments described above, as well as additional aspects and embodiments, are described further below. These aspects and/or embodiments may be used individually, all together, or in any combination of two or more, as the application is not limited in this respect.

[0024] An exemplary facet optical coupler having an offset undercut region is shown in FIG. 2. The facet optical coupler is configured to couple light between an optical fiber positioned proximate to edge **214** and waveguide **208**. As an example, the arrow and dashed curved lines shown in FIG. 2 indicate the propagation of light through the facet optical coupler **200** from an optical fiber near edge **214** into waveguide **208** along the z-direction, where the spread of the curved dashed lines indicates a variation in mode field size. Facet optical coupler **200** may be used as an optical input or an optical output by changing the direction of light propagation. Waveguide **208** may include silicon and may be considered a silicon waveguide. Although FIG. 2 shows the propagation of input light, facet coupler **200** may be configured as an optical output where light propagating through waveguide **208** couples to an optical fiber or other external optical component positioned proximate to edge **214**.

[0025] Facet optical coupler **200** includes silicon substrate **202** having an edge **212**. A layer of second material **206** is disposed on silicon substrate **202**. Waveguide **208** may be embedded within layer of second material **206**. Layer of second material **206** may be in direct contact with silicon substrate **202** at edge **212**. The surface of silicon substrate **202** and layer of second material **206** may form an interface, where an edge of the interface is located at edge **212** of silicon substrate **202**. The interface between silicon substrate **202** and layer of second material **206** may be substantially perpendicular to edge **212** of silicon substrate **202**. In some embodiments, edge **214** of layer of second material **206** may be coplanar with edge **212**. Layer of second material **206** may have a lower index of refraction than substrate **202** and may have higher index of refraction than cladding layer **210**. Layer of second material **206** may include a dielectric material, and may be considered a dielectric layer. Layer of second material **206** may include one or more of SiO₂, SiON, and Si₃N₄, by way of example and not limitation.

[0026] Facet optical coupler **200** also includes undercut region **204** disposed between a portion of silicon substrate **202** and layer of second material **206**. In some embodiments, D may be at least 10 microns, at least 20 microns, at least 50 microns, at least 100 microns, or at least 500 microns. Undercut region **204** may have an index of refraction lower than that of layer of second material **206**. In embodiments where layer of second material **206** includes silicon dioxide, undercut region **204** may have an index of refraction less than silicon dioxide. Undercut region **206** may include a gas (e.g., air), a liquid (e.g., index-matching oil), and/or a solid filler material (e.g., thermal- or UV-curable adhesive or epoxy). Undercut region **204** may be offset from edge **212** in a direction perpendicular to edge **212** of silicon substrate

202. The offset direction of undercut region **204** from edge **212** may be in a direction of light propagation through facet optical coupler **200** such that there is a region where silicon substrate **202** and layer of second material **206** are in contact between edges **212** and **214** and undercut region **204**. Edges **212** and **214** may form an edge of an integrated device having facet coupler **200**, and undercut region **204** may be offset by a certain distance from the edge of the device. By having undercut region **204** offset from edge **212**, layer of second material **206** contacts silicon substrate **202** at edge **212** and provides mechanical integrity to the edge of the integrated device, rather than having a suspended structure at the edge, such as the facet coupler structure shown in FIG. 1B. A facet optical coupler, such as **200**, where an undercut region is offset from an edge of an integrated device reduces mechanical fragility at the edge, allowing for improved production and processing of the integrated device when dicing a wafer and/or attachment of one or more optical fibers to the integrated device at the edge.

[0027] Facet optical coupler **200** may include cladding layer **210** positioned on layer of second material **206**. Cladding layer **210** may provide an index of refraction contrast at an interface between cladding layer **210** and layer of second material **206**. Cladding layer **210** may have a lower index of refraction than layer of second material **206**. Cladding layer **210** may include air or, in embodiments where layer of second material **206** is silicon dioxide, may include a material with an index of refraction lower than silicon dioxide. In some embodiments, both cladding layer **210** and undercut region **204** may include the same material.

[0028] Layer of second material **206** may have any suitable dimensions configured to couple light between waveguide **208** and edge **214** such that light couples to an external optical component positioned proximate to edge **214**. Exemplary cross-sectional configurations of facet coupler **200** along line A to A', which is at edge **212** of silicon substrate **202** and at edge **214** of layer of second material **206**, are shown in FIGS. 3A, 3B, and 3C. Layer of second material **206** contacts silicon substrate **202**, forming an interface between layer **206** and substrate **202** along the y-direction. A cross-sectional width of layer of second material **206** may vary in the y-direction to include a portion having a larger width in contact with silicon substrate **202**, such as shown in FIGS. 3B and 3C. In some instances, layer of second material **206** may have a width that covers a surface of substrate **202** such that cladding layer **210** lacks direct contact with substrate **202** as shown in FIG. 3C. A direction for the variation in cross-sectional width of layer of second material **206** may be considered perpendicular to a direction of light propagation and parallel to a surface of substrate **202**.

[0029] Undercut region **204** may have any suitable configuration. In some embodiments, undercut region **204** may extend beyond a dimension of layer of second material **206**. Exemplary cross-sectional configurations of facet optical coupler **200** along line B to B' are shown in FIGS. 4A, 4B, and 4C, corresponding to FIGS. 3A, 3B, and 3C, respectively. As shown in FIG. 4A, undercut region **204** may have a cross-sectional width, D_{width} , and height, D_{height} . Undercut region **204** may have a larger cross-sectional width than layer of second material **206** such that undercut region **204** extends beyond layer of second material **206** along the y-direction, as shown in FIGS. 4A and 4B. In some embodiments, undercut region **204** may have a similar or the same

cross-sectional width as layer of second material **206**, as shown in FIG. 4C. The cross-sectional width of undercut region **204** may be a dimension of the undercut region **204** that lies in a direction parallel to an interface between undercut region **204** and layer of second material **206**, and perpendicular to a direction of light propagation. In some embodiments, the cross-sectional width of undercut region **204** may be at least 10 microns or at least 14 microns. Undercut region **204** provides a separation between substrate **202** and layer of second material **206** by having a cross-sectional height, such as D_{height} along the x-direction shown in FIG. 4A. The dimension of undercut region **204** corresponding to a cross-sectional height may lie in a direction that is perpendicular to an interface of undercut region **204** and layer of second material **206** and perpendicular to a direction of light propagation. In some embodiments, the cross-sectional height of undercut region **204** may be at least 2 microns or at least 10 microns.

[0030] Some embodiments of the present application relate to layer of second material **206** having a lower refractive index than silicon substrate **202**, where layer of second material **206** may act as a waveguide with some amount of optical power leakage into substrate **202**. The leakage occurs primarily over a region that light propagates where there is an interface between substrate **202** and layer of second material **206**, such as dimension D shown in FIG. 2. Within this region, as an optical beam hits the interface between substrate **202** and layer **206** there is a certain amount of optical loss that occurs from refraction at the interface. In some embodiments, the design of layer of second material **206** as a waveguide may reduce optical power leakage, such as by configuring layer **206** to reduce the amount of power loss per a hit of the optical beam at the interface. In some embodiments, reducing a dimension of this region along a direction of light propagation, such as the length of D, may reduce the refraction loss and may improve coupling efficiency of the facet optical coupler.

[0031] In some embodiments, the power leakage at the interface between layer of second material **206** and substrate **202** may be reduced by suitable selection of the dimensions of the layer of second material **206** and/or the refractive indices of layer of second material **206** and cladding layer **210**. The optical modes supported by layer of second material **206** may have some amount of leakage when the refractive index of substrate **202** is higher than that of layer of second material **206**. The leakage can be understood by way of a ray optics depiction of the propagation of light through layer of second material **206**. For each mode, light travels at an angle from the propagation direction z, and is bounced back and forth at the interfaces of layer of second material **206**. The amount of power leakage per unit length depends on the incidence angle at the interface between layer of second material **206** and substrate **202**. As the angle approaches 90 degrees from the normal of the interface, the light beam may nearly graze along the interface, and the power leakage decreases. FIG. 5 is a plot illustrating the amount of leakage loss (on the y-axis) as a function of incident angle for both transverse-electric (TE) and transverse-magnetic (TM) polarizations with the example of an interface between silicon dioxide and silicon. At large incident angles approaching 90 degrees, the amount of leakage loss becomes small for both TE and TM polarizations to provide sufficient coupling efficiency for facet coupler **200**. One can obtain a large incident angle towards 90 degrees by

making the effective index of the mode very close to the refractive index of layer of second material **206**. This in turn can be achieved by making the cross-sectional dimensions of layer of second material **206** relatively large and the index of the cladding **210** relatively close to that of the layer of second material **206**, while preserving a mode size comparable to that of the external coupling mode.

[0032] Dimensions of the layer of second material, the undercut region, and/or waveguide may provide varying mode field size capabilities to allow sufficient coupling of an optical fiber, or other external optical component, with a desired mode field size to facet optical coupler. Some embodiments relate to configuring a layer of second material to reduce power lost through leakage, such as by tapering one or more dimensions of the layer to alter the field mode within the layer of second material. The layer of second material may have a decrease in size taken in a direction moving from an edge of a silicon substrate to a waveguide by having a reduced dimension in the x-direction and/or y-direction. Some embodiments may include variation along the x-direction, such as a vertical tapering and/or step profile of the height of the layer of second material. An exemplary facet optical coupler is shown in FIG. 6 where layer of second material **606** decreases in size from edge **612** of silicon substrate **602** to waveguide **608**. As shown in FIG. 5, layer of second material **606** may include a step profile, where a height of layer **606** along the x-direction decreases by a certain amount at a location overlapping with undercut region **604** and non-overlapping with waveguide **608**. Cladding layer **610** positioned on layer of second material **606** may have one or more dimensions conforming to the variation of layer **606**. Having a larger cross-sectional area of layer of second material **606** at edge **614** may facilitate mode overlap between an optical fiber positioned at edge **614** and facet coupler **600**. By reducing the cross-sectional area of layer **606**, the mode field within layer **606** is sufficiently reduced to allow coupling of light to waveguide **608**. Such a configuration may improve coupling efficiency between layer of second material **606** and waveguide **608** and/or improve the fabrication process by relaxing fabrication requirements for the waveguide **608**, such as requirements related to including an inverse taper for waveguide **608**.

[0033] Some embodiments relate to configuring a waveguide to have variation in one or more dimensions perpendicular to a direction of light propagation. A cross-sectional area of a waveguide may increase in a direction moving away from an edge the waveguide towards a center portion of the waveguide. The waveguide may have a first portion that overlaps with an undercut region and a second portion that does not overlap with the undercut region. The waveguide may increase in size moving in a direction from the first portion to the second portion. An exemplary facet optical coupler is shown in FIG. 7 where waveguide **708** has a variable dimension along the x-direction. As shown in FIG. 7, waveguide **708** may include a vertical step profile such that waveguide **708** has a smaller dimension in a region where waveguide **708** and layer of second material **706** couple. Facet optical coupler **700** also includes substrate **702**, layer of second material **706**, and cladding layer **710**. Such a configuration may improve coupling efficiency between layer of second material **706** and waveguide **708** and/or improve the fabrication process by relaxing fabrication requirements for waveguide **708**.

[0034] Some embodiments of the present application relate to a method of manufacturing a facet optical coupler having a structure described herein. Any fabrication techniques suitable for silicon-based photonic integrated circuits may be used according to some embodiments. FIG. 8 shows steps of an example of a method of manufacturing a facet optical coupler, although other suitable methods and/or additional steps may be used to form any of the facet optical couplers described above. Method **800** may start with a silicon substrate having a layer of second material formed on the silicon substrate and a layer of silicon formed on the layer of second material. In some embodiments, a wafer may include a silicon substrate, a layer of second material on the silicon substrate, and a layer of silicon on the layer of second material, such as a silicon-on-insulator (SOI) wafer. In other embodiments, method **800** may include forming a layer of second material on a silicon substrate and forming a layer of silicon on the layer of second material.

[0035] Regardless of the techniques used to achieve this initial structure, method **800** may proceed by patterning a waveguide by act **810**. Patterning the waveguide may include removing a portion of the silicon layer to achieve a desired structure for the waveguide. Method **800** may include forming additional second material on the patterned waveguide to form a layer of second material by act **820**. In this manner, the waveguide may be embedded in the layer of second material. This act may include forming a layer of second material on a surface of the silicon substrate such that an edge of the layer of second material is substantially coplanar with the edge of the silicon substrate. Method **800** may also include patterning the layer of second material by act **830** with a suitable structure and dimensions, such as the configurations shown in FIGS. 3A-3C. Some embodiments may include forming the layer of second material with a decreasing size taken in a direction moving from the edge of the silicon substrate to the waveguide.

[0036] Method **800** may include forming an undercut region in the silicon substrate at act **840**. The undercut region may have an index of refraction that differs from the silicon substrate. The silicon substrate may have a first index of refraction and the undercut region may have a second index of refraction less than the first index of refraction. The undercut region having a second index of refraction may be formed by removing a portion of the silicon substrate. For example, the portion of the silicon substrate may be removed by etching the silicon substrate at the sides of the layer of second material, such as by isotropic etching. Such techniques may allow removal of silicon both laterally and vertically to form an undercut region positioned between the silicon substrate and the layer of second material. In some embodiments, a protection layer (e.g., a photoresist mask) may be formed on the layer of second material to protect the layer of second material while forming the undercut region. In some embodiments, patterning of the layer of second material and forming the undercut region may be performed in a common set of steps by forming the protection layer in a desired pattern for the layer of second material and removing both the layer of second material and the portion of the silicon substrate removed to form the undercut region.

[0037] Forming the undercut region having the second index of refraction may include positioning the undercut region at an offset from an edge of the silicon substrate. In some embodiments, forming the undercut region having the second index of refraction may include forming the undercut

region to extend beyond the layer of second material in a direction perpendicular to a direction of light propagation and parallel to an interface of the undercut region having the second index of refraction and the layer of second material (e.g., a direction along the y-axis in FIGS. 4A-4C). In some embodiments, a dimension (e.g., D_{width} shown in FIG. 4A) of the undercut region having the second index of refraction is at least 10 microns. The dimension, D_{width} , may be considered as a dimension of the undercut region along a direction that is perpendicular to a direction of light propagation and parallel to an interface of the undercut region having the second index of refraction (e.g., a direction along the y-axis in FIGS. 4A-4C).

[0038] In some embodiments, the waveguide may have a variable dimension moving in a direction of the propagation of light. The waveguide may include a first portion overlapping the undercut region having the second index of refraction and a second portion not overlapping the undercut region where the waveguide increases in size moving in a direction from the first portion to the second portion.

[0039] In some embodiments, method **800** optionally includes filling the undercut region with a filler material having the second index of refraction by act **850**. Filling the undercut region may include filling the undercut region with a liquid (e.g., an epoxy) and/or curing the liquid to form a solid. In some embodiments, act **850** may alternatively or additionally involve forming a cladding layer disposed on the layer of second material, wherein the cladding layer has a lower index of refraction than the layer of second material. In some embodiments, filling the undercut region with a filler material and forming the cladding layer may be performed in a common set of steps. In such embodiments, the undercut region and the cladding layer may include a common material.

[0040] Having thus described several aspects and embodiments of the technology of this application, it is to be appreciated that various alterations, modifications, and improvements will readily occur to those of ordinary skill in the art. Such alterations, modifications, and improvements are intended to be within the spirit and scope of the technology described in the application. It is, therefore, to be understood that the foregoing embodiments are presented by way of example only and that, within the scope of the appended claims and equivalents thereto, inventive embodiments may be practiced otherwise than as specifically described. In addition, any combination of two or more features, systems, articles, materials, kits, and/or methods described herein, if such features, systems, articles, materials, kits, and/or methods are not mutually inconsistent, is included within the scope of the present disclosure.

[0041] Also, as described, some aspects may be embodied as one or more methods. The acts performed as part of the method may be ordered in any suitable way. Accordingly, embodiments may be constructed in which acts are performed in an order different than illustrated, which may include performing some acts simultaneously, even though shown as sequential acts in illustrative embodiments.

[0042] All definitions, as defined and used herein, should be understood to control over dictionary definitions, definitions in documents incorporated by reference, and/or ordinary meanings of the defined terms.

[0043] The indefinite articles “a” and “an,” as used herein in the specification and in the claims, unless clearly indicated to the contrary, should be understood to mean “at least one.”

[0044] The phrase “and/or,” as used herein in the specification and in the claims, should be understood to mean “either or both” of the elements so conjoined, i.e., elements that are conjunctively present in some cases and disjunctively present in other cases.

[0045] As used herein in the specification and in the claims, the phrase “at least one,” in reference to a list of one or more elements, should be understood to mean at least one element selected from any one or more of the elements in the list of elements, but not necessarily including at least one of each and every element specifically listed within the list of elements and not excluding any combinations of elements in the list of elements. This definition also allows that elements may optionally be present other than the elements specifically identified within the list of elements to which the phrase “at least one” refers, whether related or unrelated to those elements specifically identified.

[0046] In the claims, as well as in the specification above, all transitional phrases such as “comprising,” “including,” “carrying,” “having,” “containing,” “involving,” “holding,” “composed of,” and the like are to be understood to be open-ended, i.e., to mean including but not limited to. The transitional phrases “consisting of” and “consisting essentially of” shall be closed or semi-closed transitional phrases, respectively.

What is claimed is:

1. A facet optical coupler comprising:
 - a substrate having opposing first and second two-dimensional edges;
 - an undercut region in the substrate, the undercut region being proximate to and offset from the first two-dimensional edge of the substrate and being distal from the second two-dimensional edge of the substrate; and
 - a waveguide having an end over the undercut region, wherein the undercut region is closer to the first two-dimensional edge than is the end of the waveguide.
2. The facet optical coupler of claim 1, wherein the substrate further includes a surface, and the facet optical coupler further comprises a layer of second material disposed on the surface of the substrate, wherein the waveguide is embedded in the layer of second material.
3. The facet optical coupler of claim 2, wherein the layer of second material has a surface substantially co-planar with the first two-dimensional edge.
4. The facet optical coupler of claim 2, wherein the undercut region extends beyond the layer of second material in a direction perpendicular to a direction of the waveguide.
5. The facet optical coupler of claim 2, wherein a dimension of the undercut region that is parallel to an interface of the undercut region and the layer of second material is at least 10 microns.
6. The facet optical coupler of claim 2, wherein a dimension of the undercut region that is perpendicular to an interface of the undercut region and the layer of second material is at least 2 microns.
7. The facet optical coupler of claim 2, wherein the layer of second material decreases in size in a direction moving from the first two-dimensional edge of the substrate to the waveguide.

8. The facet optical coupler of claim 2, wherein the second material is a dielectric material.

9. The facet optical coupler of claim 2, wherein the second material includes one or more of SiO₂, SiON, and Si₃N₄.

10. The facet optical coupler of claim 2, further comprising a cladding layer on the layer of second material.

11. The facet optical coupler of claim 10, wherein each of the cladding layer and the undercut region has a lower refractive index than the second material.

12. The facet optical coupler of claim 1, wherein the undercut region is offset from the first two-dimensional edge of the substrate by at least 20 microns.

13. The facet optical coupler of claim 1, wherein the waveguide has a first portion overlapping the undercut region and a second portion not overlapping the undercut region, and wherein the waveguide increases in size moving in a direction from the first portion to the second portion.

14. A method of manufacturing a facet optical coupler, the method comprising:

forming a region in a substrate such that the region has a lower index of refraction than the substrate and is positioned proximate to but offset from a first planar edge of the substrate and distal a second planar edge of the substrate opposite the first planar edge; and

forming a waveguide terminating over the region such that a distance between the waveguide and the first planar edge is greater than a distance between the region and the first planar edge.

15. The method of claim 14, wherein forming the region comprises positioning the region at an offset of at least 20 microns from the first planar edge of the substrate.

16. The method of claim 14, wherein forming the region comprises removing and filling a portion of the substrate with a filler material having the lower index of refraction.

17. The method of claim 14, further comprising forming a layer of second material over the substrate and forming a cladding layer on the layer of second material, wherein the waveguide is embedded in the layer of second material and the cladding layer has a lower index of refraction than the layer of second material.

18. The method of claim 17, wherein forming the region comprises forming the region to extend beyond the layer of second material in a direction perpendicular to a direction of the waveguide.

19. The method of claim 17, wherein forming the layer of second material comprises forming the layer of second material with a decreasing size in a direction moving from the first planar edge of the substrate to the waveguide.

20. The method of claim 14, wherein forming the waveguide comprises forming the waveguide with a first portion overlapping the region and a second portion not overlapping the region, and wherein the waveguide increases in size moving in a direction from the first portion to the second portion.

* * * * *