



US009427984B2

(12) **United States Patent**  
**Matsuya et al.**

(10) **Patent No.:** **US 9,427,984 B2**

(45) **Date of Patent:** **Aug. 30, 2016**

(54) **PRINTER WITH CUTTER PROTECTION MECHANISM**

(71) Applicant: **FUJITSU COMPONENT LIMITED**,  
Tokyo (JP)

(72) Inventors: **Tomoyuki Matsuya**, Tokyo (JP);  
**Yoshinari Takabatake**, Tokyo (JP)

(73) Assignee: **FUJITSU COMPONENT LIMITED**,  
Tokyo (JP)

(\* ) Notice: Subject to any disclaimer, the term of this  
patent is extended or adjusted under 35  
U.S.C. 154(b) by 16 days.

(21) Appl. No.: **14/600,109**

(22) Filed: **Jan. 20, 2015**

(65) **Prior Publication Data**

US 2015/0138299 A1 May 21, 2015

**Related U.S. Application Data**

(62) Division of application No. 13/713,265, filed on Dec.  
13, 2012, now Pat. No. 8,967,893.

(30) **Foreign Application Priority Data**

Dec. 22, 2011 (JP) ..... 2011-282405

(51) **Int. Cl.**

**B41J 11/70** (2006.01)

**B26D 7/22** (2006.01)

**B41J 15/04** (2006.01)

**B41J 29/13** (2006.01)

**B26D 7/00** (2006.01)

(52) **U.S. Cl.**

CPC ..... **B41J 11/70** (2013.01); **B26D 7/22**  
(2013.01); **B41J 15/042** (2013.01); **B41J**  
**29/13** (2013.01); **B26D 2007/005** (2013.01)

(58) **Field of Classification Search**

CPC ..... B41J 11/70; B41J 11/77; B41J 29/13;  
B41J 11/06; B41J 29/136; B41J 11/66;  
G05B 5/027; G05B 5/02; B26D 7/22; G07B  
5/02

See application file for complete search history.

(56) **References Cited**

U.S. PATENT DOCUMENTS

6,118,469 A \* 9/2000 Hosomi ..... B26D 1/305  
347/222

7,510,343 B1 3/2009 Arrington et al.

2010/0143018 A1 6/2010 Kawaguchi

2011/0170930 A1 7/2011 Kawaguchi

2012/0057918 A1 3/2012 Eoka

FOREIGN PATENT DOCUMENTS

JP S56-060164 5/1981

JP H04-371442 12/1992

(Continued)

*Primary Examiner* — Daniel J Colilla

(74) *Attorney, Agent, or Firm* — IPUSA, PLLC

(57) **ABSTRACT**

A printer includes a main body case in which a sheet roll is installed, a sheet discharge port from which a printed sheet of paper is discharged, an opening/closing cover that opens and closes with respect to the main body case, a cutter that is attached to the opening/closing cover and configured to cut the printed sheet of paper from the sheet roll, and a cutter protection mechanism configured to move in correspondence with an opening movement or a closing movement of the opening/closing cover. The cutter protection mechanism is configured to expose the cutter at the sheet discharge port when the opening/closing cover is in a closed state and conceal the cutter when the opening/closing cover is in an open state.

**2 Claims, 10 Drawing Sheets**

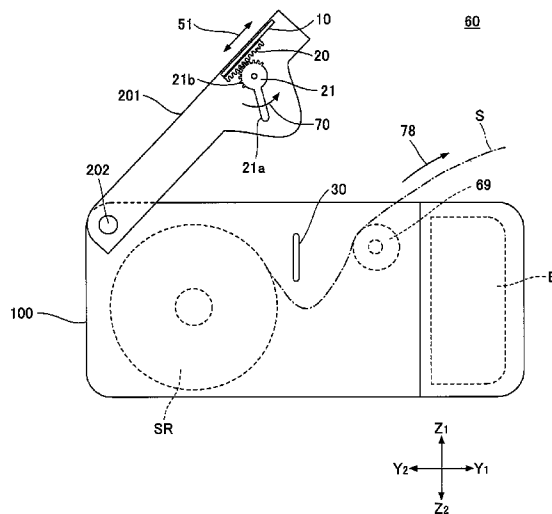

(56)

**References Cited**

FOREIGN PATENT DOCUMENTS

JP H07-164695 6/1995  
JP 2003-127091 5/2003

JP 2003-211756 7/2003  
JP 2008119838 A \* 5/2008  
JP 2009-166238 7/2009  
JP 2010-179467 8/2010  
JP 2011-140199 7/2011

\* cited by examiner

FIG. 1

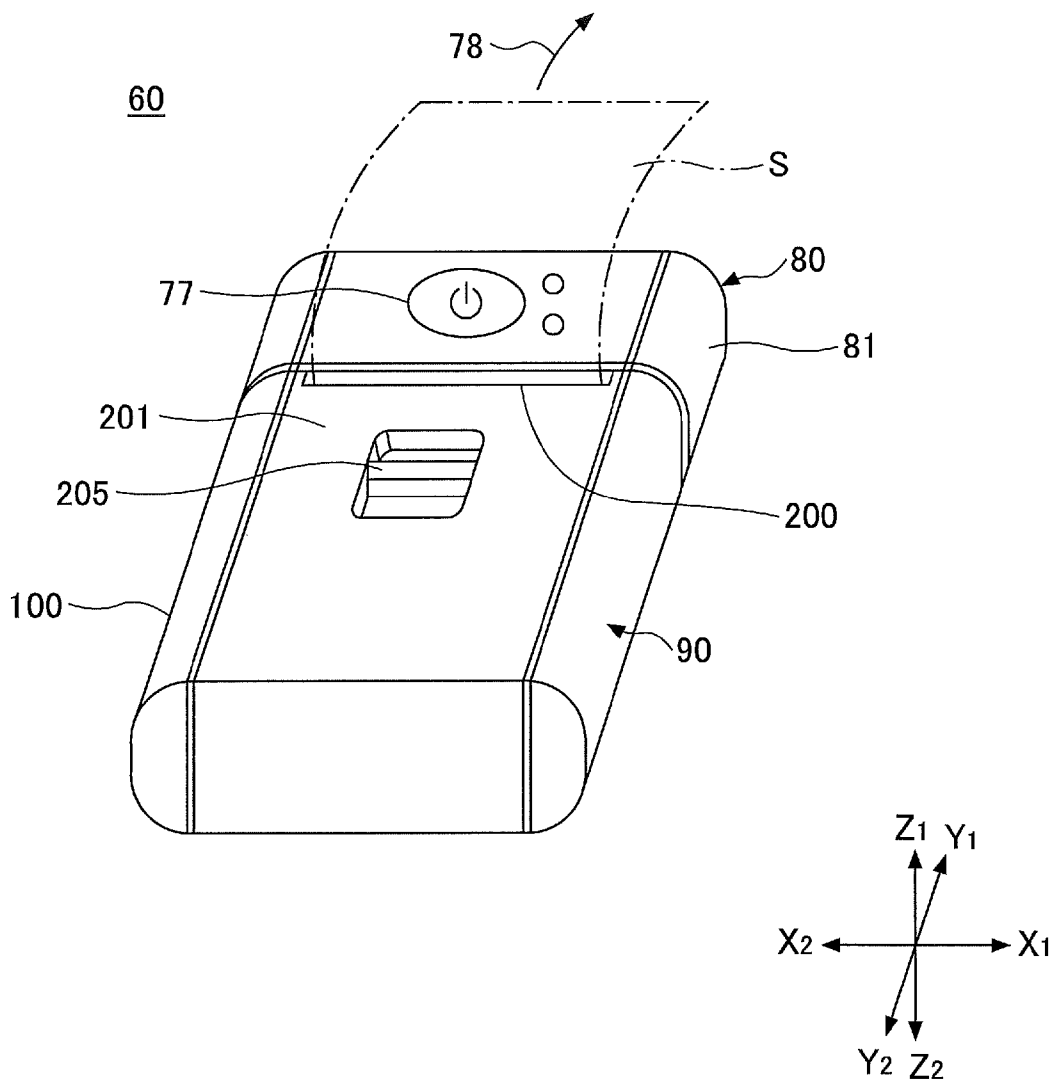

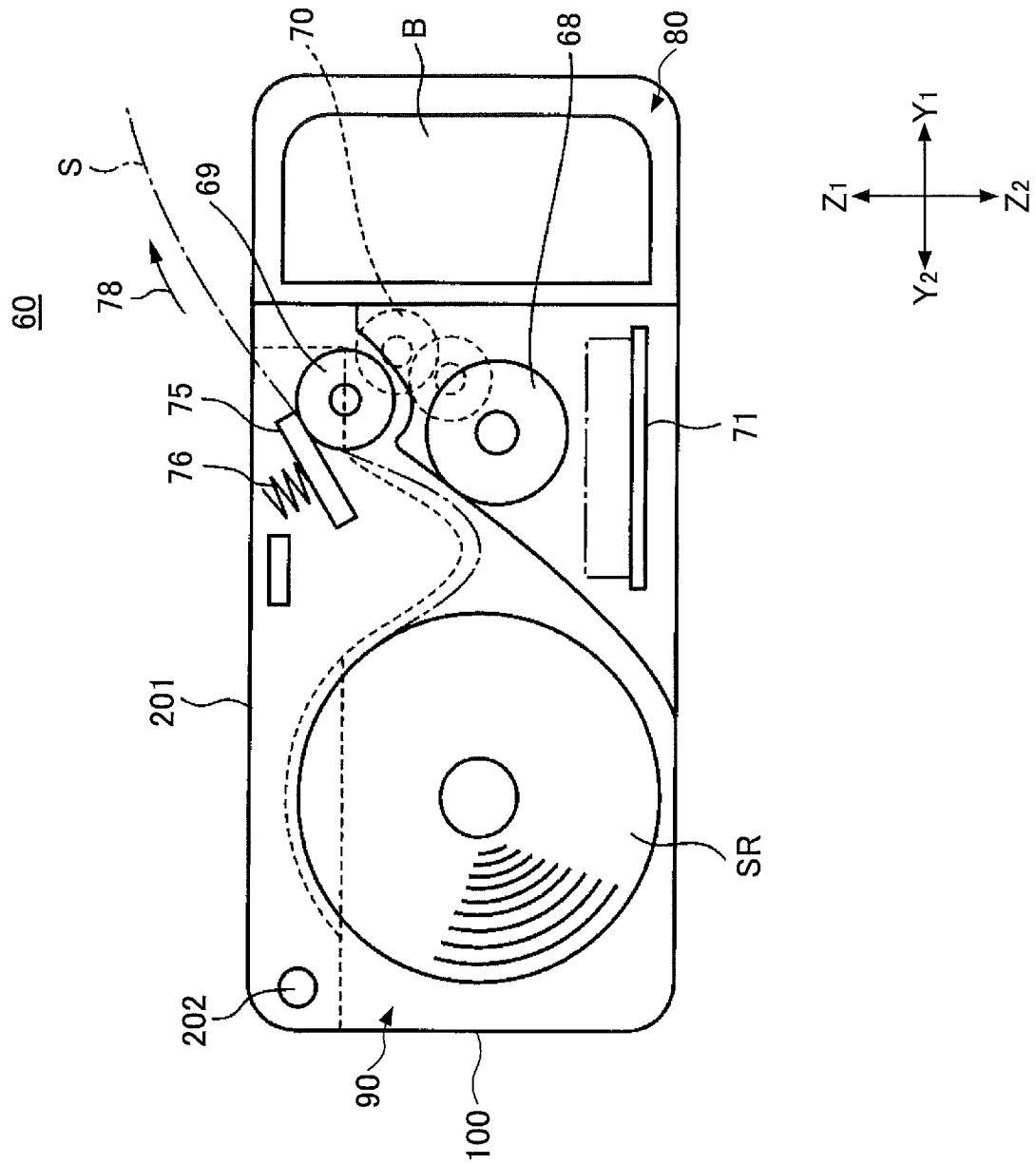

FIG. 2

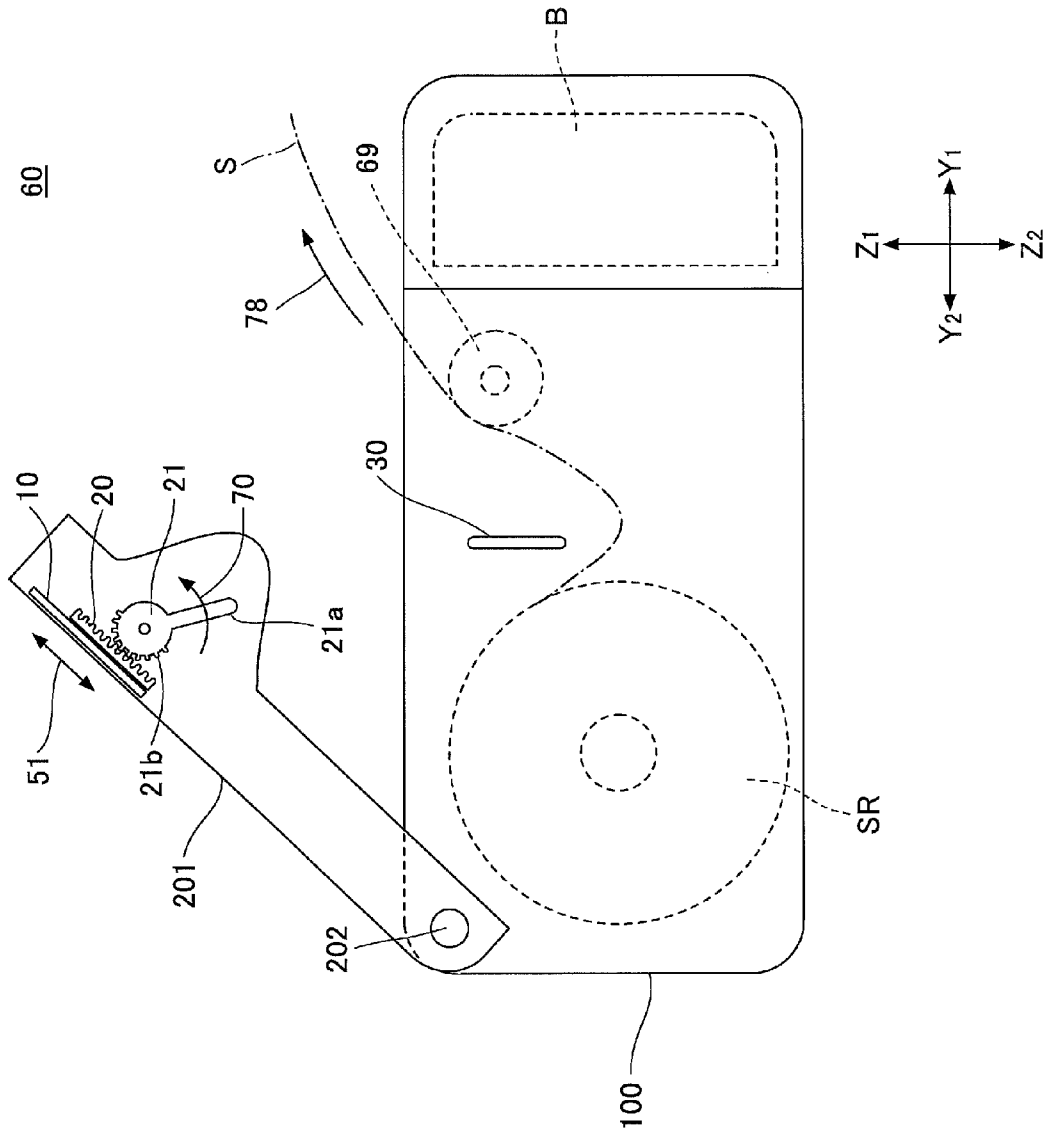

FIG. 3

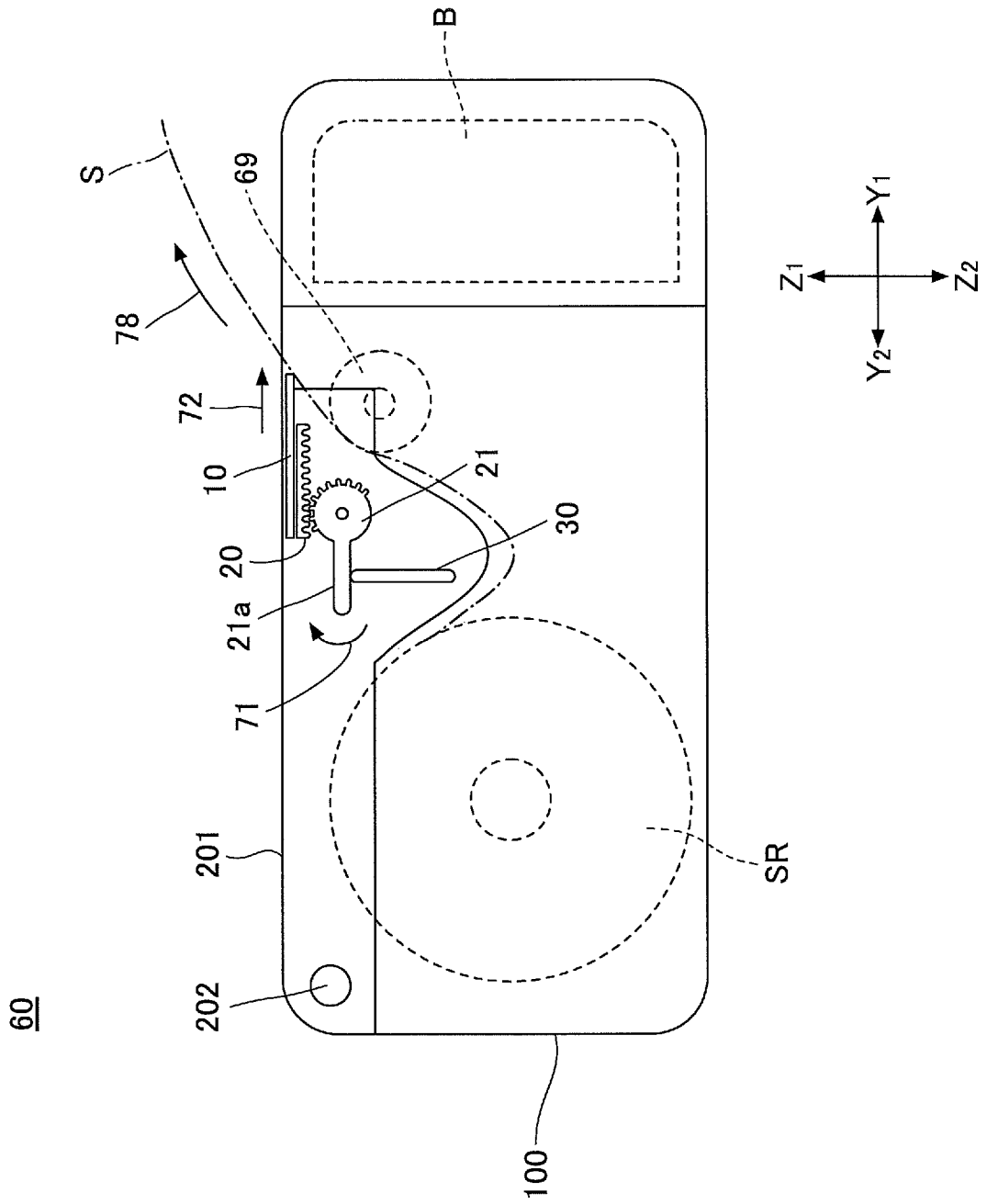

FIG. 4

FIG.5A

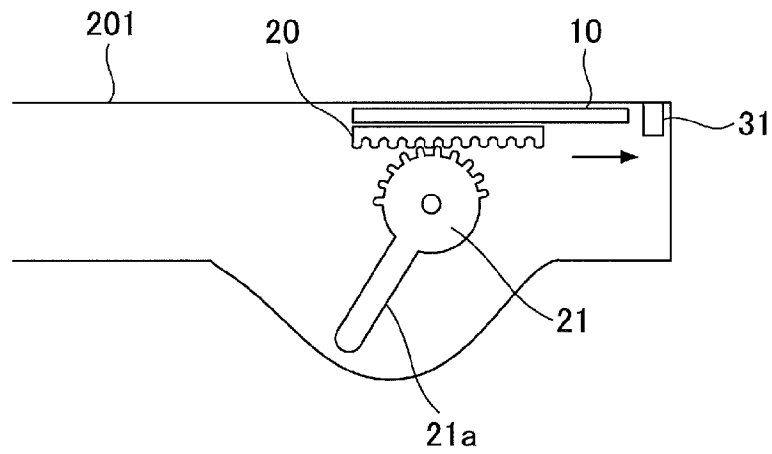
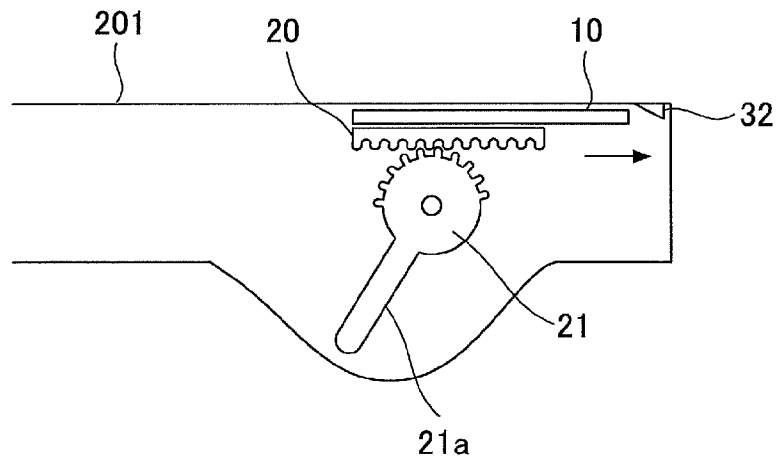

FIG.5B



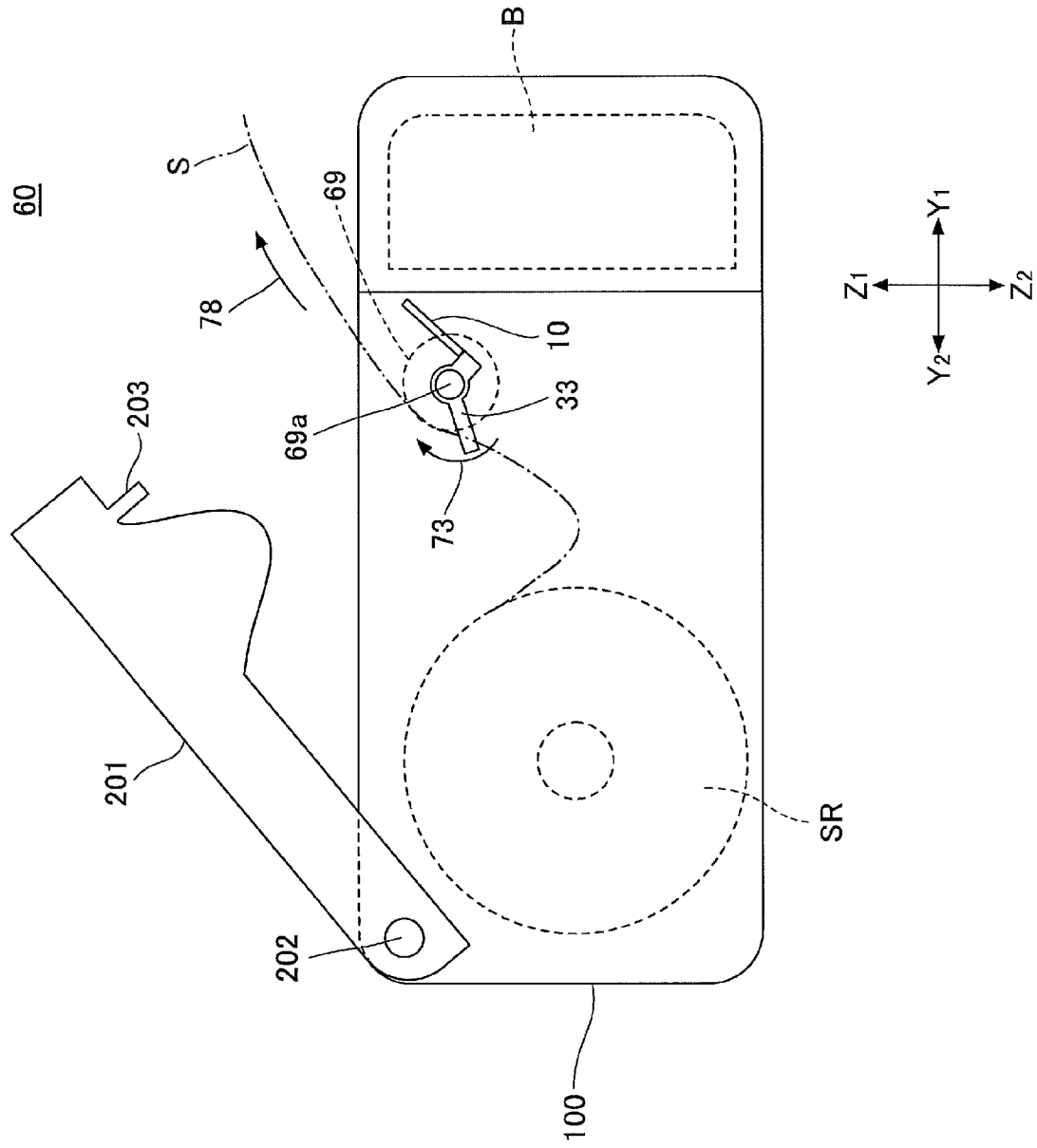

FIG. 6



60

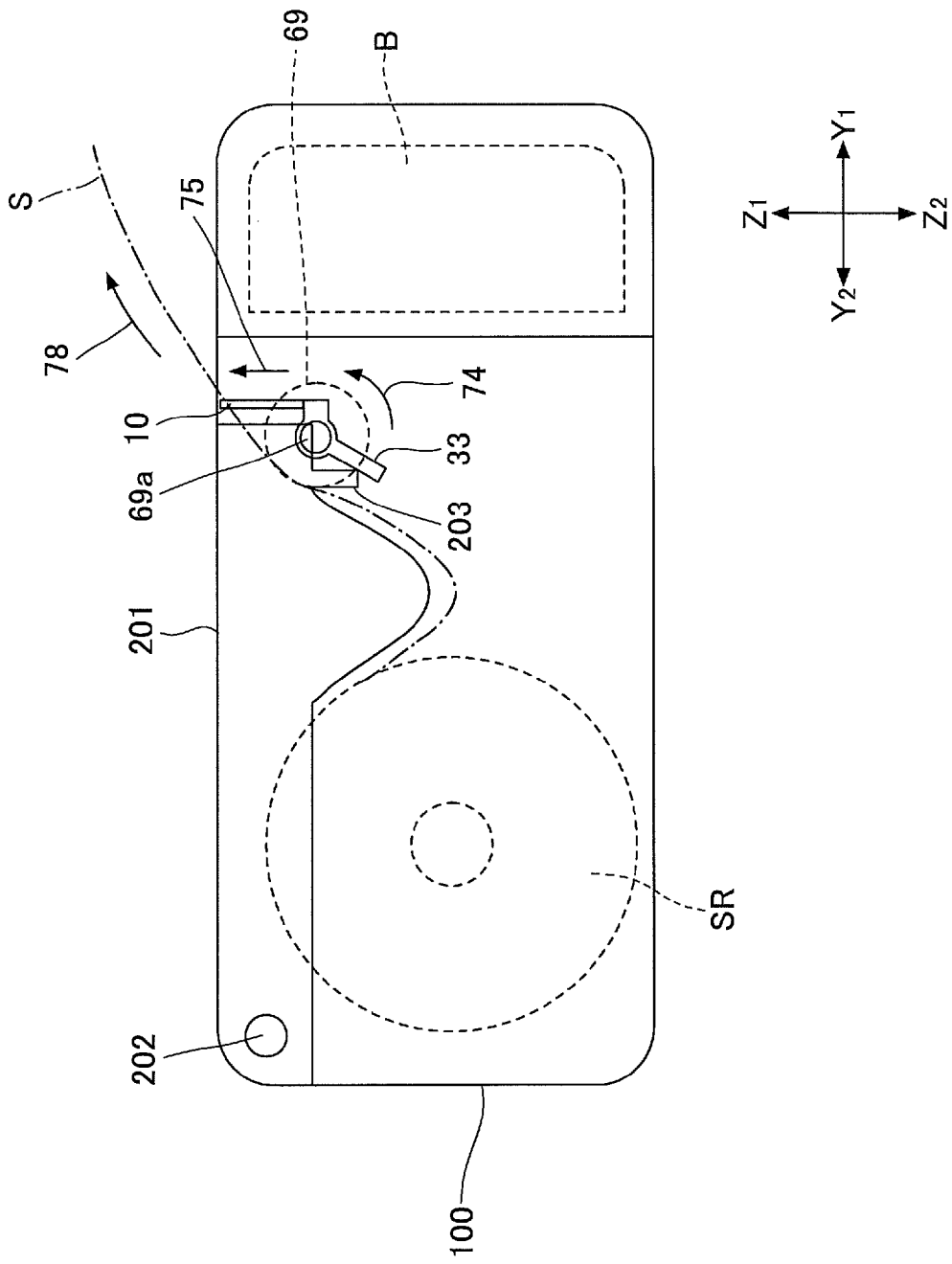

FIG. 7

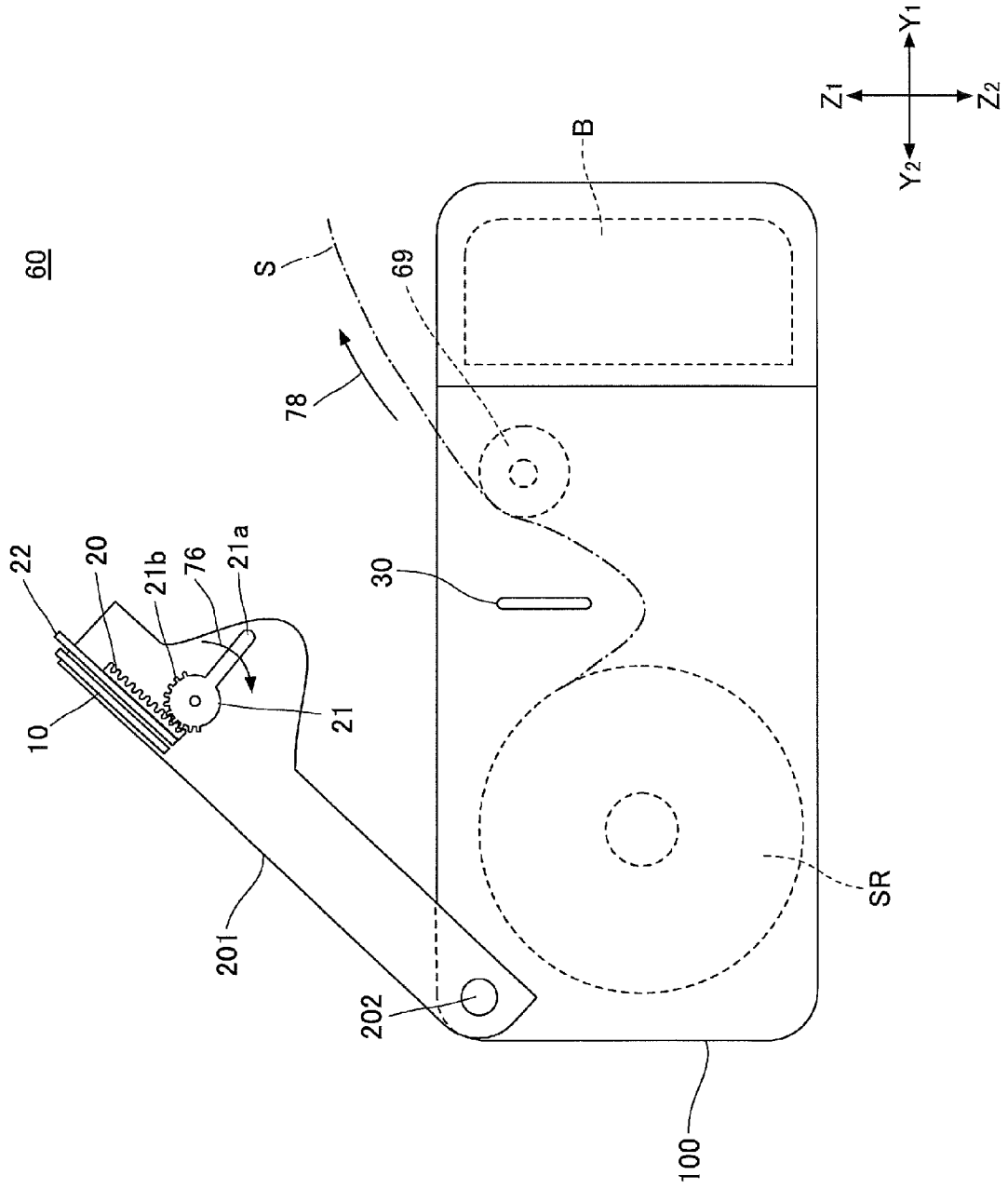

FIG. 8

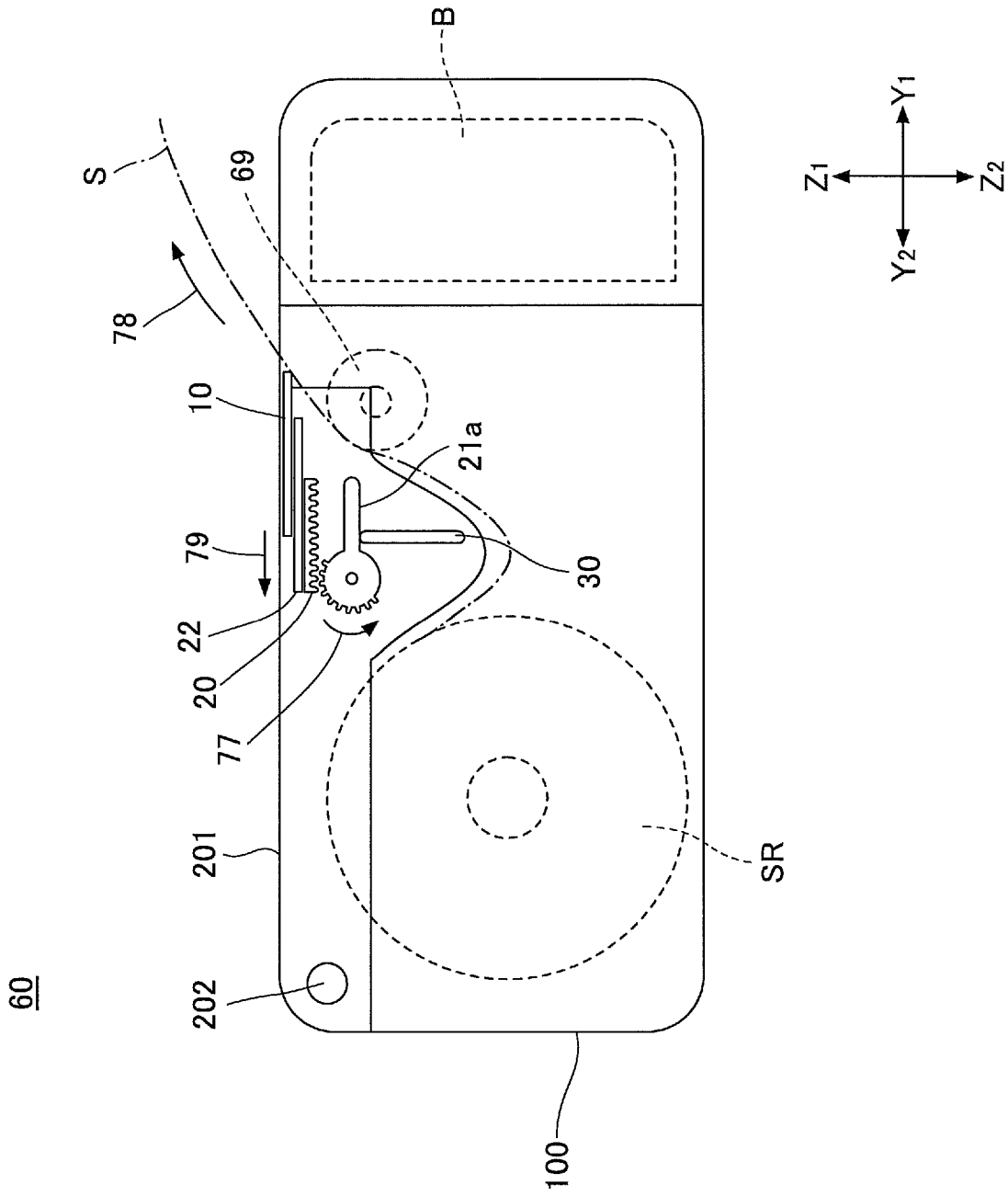

FIG. 9

FIG.10A

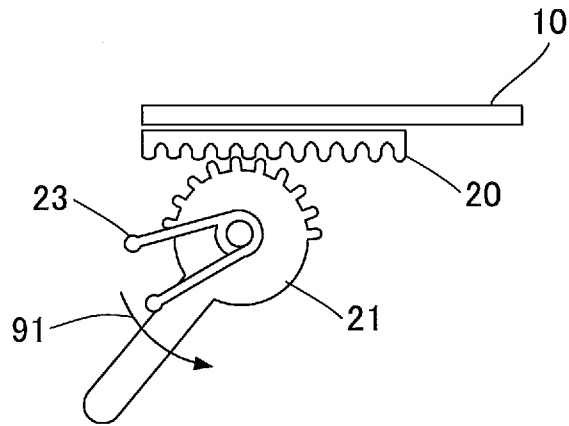

FIG.10B

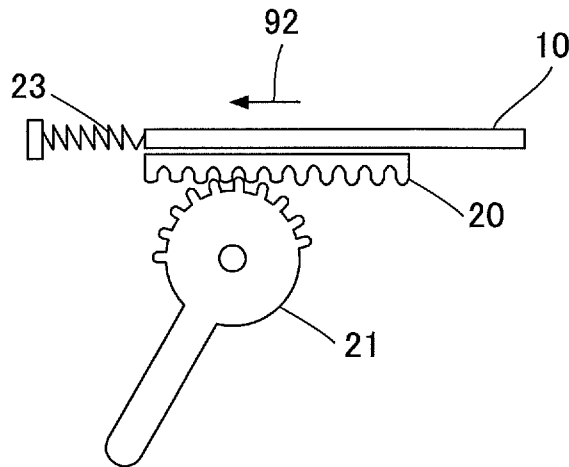
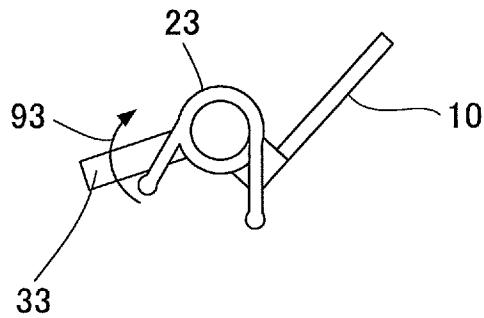

FIG.10C



1

## PRINTER WITH CUTTER PROTECTION MECHANISM

### CROSS-REFERENCE TO RELATED APPLICATION

This application is a divisional patent application of, and claims the benefit of and priority to, U.S. patent application Ser. No. 13/713,265 filed on Dec. 13, 2012, which claims the benefit of priority of Japanese Patent Application No. 2011-282405 filed on Dec. 22, 2011, with the Japanese Patent Office, all of which are hereby incorporated by reference.

### BACKGROUND OF THE INVENTION

#### 1. Field of the Invention

The present invention generally relates to a printer.

#### 2. Description of the Related Art

Typically, a portable type printer, which performs printing on continuous paper (e.g., roll paper), has a paper cutter mounted thereon. The paper cutter is used to cut the continuous paper discharged from the portable type printer. The portable type printer includes a case body for installing the continuous paper therein. The portable type printer also includes an opening/closing cover that opens and closes for loading or replacing the continuous paper. The paper cutter is mounted on either the case body or the opening/closing cover in the vicinity of a sheet discharge port of the portable type printer.

The paper cutter, which is located in the vicinity of the paper discharge port, is exposed when the opening/closing cover is in an open state. This may result in a user being cut by the paper cutter at the time of, for example, loading the continuous paper.

For example, Japanese Laid-Open Patent Publication No. 7-164695 discloses a receipt printer having a shaft that cooperatively moves with an upper cover, in which a cutting blade is prevented from advancing forward by a tip part of the shaft that protrudes in front of the cutting blade when the upper cover is opened.

However, with the receipt printer disclosed in Japanese Laid-Open Patent Publication No. 7-164695, contact or the like may be caused upon the upper lever in a state where the upper cover is open during an operation of, for example, paper replacement. The contact may cause a lock lever to detach from a pin and result in exposure of the cutting blade. By continuing operation in the state where the cutting blade is exposed, the user could be injured by inadvertently touching the cutting blade.

### SUMMARY OF THE INVENTION

The present invention may provide a printer that substantially eliminates one or more of the problems caused by the limitations and disadvantages of the related art.

Features and advantages of the present invention will be set forth in the description which follows, and in part will become apparent from the description and the accompanying drawings, or may be learned by practice of the invention according to the teachings provided in the description. Objects as well as other features and advantages of the present invention will be realized and attained by a printer particularly pointed out in the specification in such full, clear, concise, and exact terms as to enable a person having ordinary skill in the art to practice the invention.

To achieve these and other advantages and in accordance with the purpose of the invention, as embodied and broadly

2

described herein, an embodiment of the present invention provides a printer including a main body case in which a sheet roll is installed, a sheet discharge port from which a printed sheet of paper is discharged, an opening/closing cover that opens and closes with respect to the main body case, a cutter that is attached to the opening/closing cover and configured to cut the printed sheet of paper from the sheet roll, and a cutter protection mechanism configured to move in correspondence with an opening movement or a closing movement of the opening/closing cover, wherein the cutter protection mechanism is configured to expose the cutter at the sheet discharge port when the opening/closing cover is in an open state and conceal the cutter when the opening/closing cover is in a closed state.

Other objects and further features of the present invention will be apparent from the following detailed description when read in conjunction with the accompanying drawings.

### BRIEF DESCRIPTION OF THE DRAWINGS

FIG. 1 is a perspective view illustrating a portable type thermal printer according to an embodiment of the present invention;

FIG. 2 is a schematic diagram illustrating an internal structure of the portable type thermal printer of FIG. 1;

FIG. 3 is a schematic side view illustrating an open state of an opening/closing cover of a thermal printer according to a first embodiment of the present invention;

FIG. 4 is a schematic side view illustrating a closed state of an opening/closing cover of a thermal printer according to the first embodiment of the present invention;

FIGS. 5A and 5B are schematic diagrams illustrating a cleaning member and a polishing member of a thermal printer according to a second embodiment of the present invention;

FIG. 6 is a schematic side view illustrating an open state of an opening/closing cover of a thermal printer according to the second embodiment of the present invention;

FIG. 7 is a schematic side view illustrating a closed state of an opening/closing cover of a thermal printer according to the second embodiment of the present invention;

FIG. 8 is a schematic side view illustrating an open state of an opening/closing cover of a thermal printer according to a third embodiment of the present invention;

FIG. 9 is a schematic side view illustrating a closed state of an opening/closing cover of a thermal printer according to the third embodiment of the present invention; and

FIGS. 10A-10C are schematic diagrams illustrating a configuration including a pinion gear, a cutter, and an urging part of a holding member according to an embodiment of the present invention.

### DESCRIPTION OF THE PREFERRED EMBODIMENTS

In the following, embodiments of a printer (e.g., thermal printer) of the present invention are described with reference to the accompanying drawings.

FIGS. 1 and 2 illustrate a thermal printer 60 according to an embodiment of the present invention. In the drawings, arrows X1-X2 indicate the width direction, arrows Y1-Y2 indicate the depth direction, and arrows Z1-Z2 indicate the height direction of the thermal printer 60 according to an embodiment of the present invention.

The thermal printer 60 includes a main body case 100 having a substantially rectangular parallelepiped shape. A sheet roll installing part 90 for installing a sheet roll SR

therein, a conveying mechanism for conveying the sheet roll SR, and a battery installing part **80** for installing a battery B therein are provided inside the main body case **100**. The thermal printer **60** is formed in a portable size.

The thermal printer **60**, which is a so-called clam shell type printer, also includes an opening/closing cover **201**. By opening the opening/closing cover **201**, the sheet roller SR can easily be, for example, replaced or removed from the thermal printer **60**.

The battery installing part **80** is positioned on the Y1 side of the main body case **100**. The sheet roll installing part **90** is positioned on the Y2 side of the main body **100**. The battery installing part **80** includes a cover **81**. The battery B can be replaced by opening and closing the cover **81**.

The main body case **100** also has, for example, a sheet conveying motor **68**, a platen roller **69**, a gear mechanism **70**, and a control circuit board **71** installed therein. The gear mechanism **70** serves to transmit the rotation of the sheet conveying motor **68** to the platen roller **69**.

The opening/closing cover **201** is positioned at an upper part of the sheet roller installing part **90**. The inside of the sheet roller installing part **90** is exposed by rotating the opening/closing cover **201**, in the Z1 direction, around an axle member **202**, so that the sheet roller SR can be easily loaded or replaced.

The opening/closing cover **201** includes a thermal head **75** located in a position that contacts the platen roller **69** when the opening/closing cover **201** is in a closed state. A spring **76** urges (i.e. exerts pressure on) the platen roller **69** when the platen roller **69** is in a state contacting the thermal head **75**. Further, an operation button **77** and an open/close lever **205** are arranged at an upper part (Z1 direction) of the opening/closing cover **201**.

The thermal printer **60** is ready to be used when a sheet S of the sheet roll SR is in a state nipped between the thermal head **75** and the platen roller **69** by installing the battery B in the battery installing part **80**, closing the cover **81**, installing the sheet roll SR in the sheet installing part **90**, pulling out a sheet S of the sheet roll SR, and closing the opening/closing cover **201**.

Printing is performed on the sheet S by driving the motor **68** in accordance with commands sent from an external device by way of, for example, wireless, cable, or infrared communication. Accordingly, the motor **68** causes the platen roller **69** to convey the sheet S from the sheet roll R to a predetermined position between the thermal head **75** and the platen roller **69**, so that printing can be performed on the sheet S. After letters or the like are printed on a surface of the sheet S, the sheet S is delivered to a sheet discharge port **200** in a direction indicated by an arrow **78** in FIG. 2.

The sheet S discharged from the sheet discharge port **200** is cut off in a direction that substantially perpendicularly intersects the direction in which the sheet S is conveyed (sheet conveying direction). The sheet S is cut off by a cutter **10** (see, for example, FIG. 3) provided in the vicinity of the sheet discharge port **200**.

[First Embodiment]

FIGS. 3 and 4 illustrate an example of a configuration of the thermal printer **60** according to the first embodiment of the present invention. FIGS. 3 and 4 are for describing movements in the thermal printer **60** during the opening/closing of the opening/closing cover **201**. FIG. 3 is a schematic side view of the thermal printer **60** in a state where the opening/closing cover **201** is open. FIG. 4 is a schematic side view of the thermal printer **60** in a state where the opening/closing cover **201** is closed.

The opening/closing cover **201** includes the cutter **10** for cutting the sheet S. The cutter **10** is movable in a direction indicated by an arrow **51** in FIG. 3. A rack gear **20** is attached to an end part of the cutter **10**. Further, the opening/closing cover **201** includes a pinion gear **21** which rotates by engaging the rack gear **20** attached to the end part of the cutter **10**.

The pinion gear **21** includes a rod part **21a** and a gear part **21b**. The rod part **21a** having a pole-like shape projects from a peripheral surface of the pinion gear **21**. The gear part **21b** is configured to mesh with the rack gear **20**. Accordingly, the below-described urging member urges (i.e. exerts pressure on) the pinion gear **21**, so that the pinion gear **21** can rotate in a direction indicated by an arrow **70** of FIG. 3. In a state where no pressure is exerted on the pinion gear **21**, the pinion gear **21** is configured to move the cutter **10** toward the inside of the opening/closing cover **201** via the rack gear **20**.

For example, a spring **23** may be used as the urging member for urging (i.e. exerting pressure on) the pinion gear **21**. The spring **23** may be positioned in a manner illustrated in FIG. 10A to urge the pinion gear **21** in a direction indicated by an arrow **91**. Alternatively, the spring **23** may be positioned in manner illustrated in FIG. 10B to urge the cutter **10** in a direction indicated by an arrow **92** of FIG. 10B.

Further, a rib **30** is arranged in an inner side surface of the main body case **100**. The rib **30** is positioned to push the rod part **21a** upward and rotate the pinion gear **21** when closing the opening/closing cover **201**. As illustrated in FIG. 4, the rib **30** contacts the rod part **21a** when the opening/closing cover **201** is in a closed state. In this closed state, the rib **30** rotates the pinion gear **21** in a direction indicated by an arrow **71** of FIG. 4, so that the cutter **10** is moved in a direction indicated by an arrow **72** by way of the rack gear **20**. Thereby, the cutter **10** is exposed at the sheet discharge port **200**.

Hence, the cutter **10** can be moved to be installed in the opening/closing cover **201** in a case where the opening/closing cover **201** is in an open state (as illustrated in FIG. 3) by providing a cutter protection mechanism including the rack gear **20**, the pinion gear **21**, the urging part (e.g., spring **23**) of the pinion gear **21**, and the rib **30**. That is, with the cutter protection mechanism, the cutter **10** can be installed inside the opening/closing cover **201** in a case where the opening/closing cover **201** is in an open state by exerting pressure on the pinion gear **21**, so that the pinion gear **21** is rotated in a direction indicated by an arrow **70** of FIG. 3 and the gear part **21b** and the rack gear **20** are engaged.

In a case where the opening/closing cover **201** is in a closed state, the rib **30** arranged in the main body case **100** pushes the rod part **21b** of the pinion gear **21** upward and rotates the pinion gear **21** in a direction indicated by an arrow **71** in FIG. 4. The cutter **10**, which includes the rack gear **20** that meshes with the pinion gear **21**, moves in a direction indicated by an arrow **72** in FIG. 4 in a case where the pinion gear **21** is moved in the direction indicated by the arrow **71** in FIG. 4. Thereby, the cutter **10** is moved from a state installed in the opening/closing cover **201** to a state exposed at the sheet discharge port **200**. By exposing the cutter **10** at the sheet discharge part **200** in a case where the opening/closing cover **201** is in a closed state, a sheet S, after having letters or the like printed thereon, can be cut off by pressing the sheet S against the cutter **10**.

With the thermal printer **60** according to the first embodiment of the present invention, an operator can be prevented from being cut or injured by contact with the cutter **10** during an operation of loading or replacing a sheet roll SR

5

owing to the cutter 10 installed in the opening/closing cover 201 in a case where the opening/closing cover 201 is in an open state.

As illustrated in FIGS. 5A and 5B, a cleaning member 31 or a polishing member 32 may be arranged at a position enabling the cutter 10 to move toward and contact the cleaning member 31 or the polishing member 32 when the opening/closing cover 201 is opened or closed. FIG. 5A illustrates an example of a configuration of the thermal printer 60 including the cleaning member 31. FIG. 5B illustrates an example of a configuration of the thermal printer 60 including the polishing member 32.

The cleaning member 31 may be, for example, a sponge made by foaming a synthetic resin such as polyurethane. Paper particles and foreign material adhered to the cutter 10 can be removed when the cutter 10 moves in correspondence with the opening or closing of the opening/closing cover 201.

Accordingly, cutting failure due to foreign matter caught between the sheet S and the cutter 10 can be prevented by providing the cleaning member 31.

Further, the polishing member 32 may be, for example, an abrasive grinding wheel that polishes the blade of the cutter 10 whenever the cutter 10 moves. Accordingly, the cutter 10 can maintain a state similar to a brand new state. Thus, the life span of the cutter 10 can be prevented from being shortened due to wear of the blade of the cutter 10.

Further, by providing both the cleaning member 31 and the polishing member 32 in the thermal printer 60, the above-described effects attained by cleaning member 31 and the polishing member 32 can be attained at the same time.

[Second Embodiment]

FIGS. 6 and 7 illustrate an example of a configuration of the thermal printer 60 according to the second embodiment of the present invention. FIGS. 6 and 7 are for describing movements in the thermal printer 60 during the opening/closing of the opening/closing cover 201. In the second embodiment, like components are denoted by like reference numerals as those of the first embodiment and are not further explained.

The main body case 100 includes a retaining member 33 which retains the cutter 10. The retaining member 33 is rotatably supported by a shaft 69a of the platen roller 69 of the main body case 100. A spring or the like urges the retaining member 33 in a direction indicated by an arrow 73 of FIG. 6. In a state where the opening/closing cover 201 is in an open state as illustrated in FIG. 6, the retaining member 33 is urged to rotate in a direction indicated by the arrow 73, so that the cutter 10 is rotated and installed in the main body case 100. For example, the spring 23 illustrated in FIG. 100 may be used as an urging member for urging the retaining member 33. The spring 23 may be arranged to urge the retaining member 33 in a direction indicated by an arrow 93 of FIG. 100.

The opening/closing cover 201 includes a projecting part 203 formed in a position at which the projecting part 230 contacts the retaining member 33 and rotates the retaining member 33. In a case where the opening/closing cover 201 is in a closed state as illustrated in FIG. 7, the projecting part 203 of the opening/closing cover 201 depresses the retaining member 33 and rotates the retaining member 33 in a direction indicated by an arrow 74. Thereby, the cutter 10, being retained by the retaining member 33, is exposed at the sheet discharge port 200.

Hence, the cutter 10 can be moved to be installed in the opening/closing cover 201 in a case where the opening/closing cover 201 is in an open state by providing a cutter

6

protection mechanism including the projecting part 203 of the opening/closing cover 201, the retaining member 33 (which retains the cutter 10 and is rotatably supported by, for example, the shaft of the platen roller 69), and the urging member 23 (which urges the retaining member 33). Therefore, even in a case of loading or replacing the sheet roll SR, the operator can be prevented from being cut by the cutter 10.

[Third Embodiment]

FIGS. 8 and 9 illustrate an example of a configuration of the thermal printer 60 according to the third embodiment of the present invention. FIGS. 8 and 9 are for describing movements in the thermal printer 60 during the opening/closing of the opening/closing cover 201. In the third embodiment, like components are denoted by like reference numerals as those of the first embodiment and are not further explained.

The cutter 10 is fixed to the opening/closing cover 201, so that the cutter 10 is in a position exposed at the sheet discharge port 200. That is, the cutter 10 is attached to the opening/closing cover 201 in a manner that the cutter 10 is unable to move. The opening/closing cover 201 includes a shutter 22 that can move in positions exposing and covering the cutter 10.

The rack gear 20 is arranged at an end part of the shutter 22. The rack gear 20 meshes with the pinion gear 21 that is rotatably supported by a shaft or the like. The pinion gear 21 is urged in a direction indicated by an arrow 76 of FIG. 8 by an urging member. The pinion gear 21 includes a rod part 21a projecting from a peripheral surface of the pinion gear 21 and a gear part 21b. By urging the pinion gear 21 in a direction indicated by an arrow 76 of FIG. 9, the shutter 22 is moved to a position covering the cutter 10 in a state where the opening/closing cover 201 is open.

Similar to the first embodiment, a spring 23 or the like may be used as the urging part that urges the pinion gear 21. Accordingly, the spring 23 may urge the pinion gear 21 in a direction indicated by the arrow 76 of FIG. 8, so that the pinion gear 21 causes the shutter 22 to move toward a position covering the cutter 10.

Further, the rib 30 is arranged in an inner side surface of the main body case 100. The rib 30 is positioned to push the rod part 21a upward and rotate the pinion gear 21 when closing the opening/closing cover 201. As illustrated in FIG. 9, the rib 30 contacts the rod part 21a when the opening/closing cover 201 is in a closed state. In this closed state, the rib 30 rotates the pinion gear 21 in a direction indicated by an arrow 77 of FIG. 9, so that the shutter 22 is moved in a direction indicated by an arrow 79 by way of the rack gear 20. Thereby, the cutter 10 is exposed at the sheet discharge port 200.

Hence, the shutter 22 can be moved to cover the cutter 10 in a case where the opening/closing cover 201 is in an open state (as illustrated in FIG. 8) and moved to expose the cutter 10 at the sheet discharge port 200 in a case where the opening/closing cover 201 is in a closed state (as illustrated in FIG. 9) by providing a cutter protection mechanism including the shutter 22, the rack gear 20, the pinion gear 21, the urging part (e.g., spring 23) of the pinion gear 21, and the rib 30.

Therefore, even in a case of loading or replacing the sheet roll SR, the operator can be prevented from being cut by the cutter 10 owing to the cutter 10 covered by the shutter 22 in a state where the opening/closing cover 201 is open.

All examples and conditional language recited herein are intended for pedagogical purposes to aid the reader in understanding the invention and the concepts contributed by

the inventor to furthering the art, and are to be construed as being without limitation to such specifically recited examples and conditions, nor does the organization of such examples in the specification relate to a showing of the superiority and inferiority of the invention. Although the embodiments of the present invention have been described in detail, it should be understood that the various changes, substitutions, and alterations could be made hereto without departing from the spirit and scope of the invention.

What is claimed is:

1. A printer comprising:

- a main body case in which a sheet roll is installed;
- a sheet discharge port from which a printed sheet of paper is discharged;
- an opening/closing cover that opens and closes with respect to the main body case;
- a cutter that is attached to the opening/closing cover and configured to cut the printed sheet of paper from the sheet roll; and
- a cutter protection mechanism configured to move in correspondence with an opening movement or a closing movement of the opening/closing cover;
- wherein the cutter protection mechanism is configured to expose the cutter at the sheet discharge port when the opening/closing cover is in a closed state and conceal the cutter when the opening/closing cover is in an open state,
- wherein the cutter is attached to the opening/closing cover in a manner such that the cutter is unable to move,
- wherein the cutter protection mechanism includes a shutter that is movable with respect to the opening/closing cover, and
- wherein the shutter is configured to expose the cutter in correspondence with the closing movement of the opening/closing cover and conceal the cutter in correspondence with the opening movement of the opening/closing cover,
- wherein the cutter protection mechanism further includes a rack gear that is fixed to an end part of the shutter, a pinion gear configured to mesh with the rack gear and rotate relative to the rack gear,
- an urging part configured to urge the cutter or the pinion gear in a direction causing the shutter to cover the cutter, and

- a rib that is formed on an inner side surface of the main body case,
  - wherein the pinion gear includes a rod part projecting from a peripheral surface of the pinion gear,
  - wherein the rib is configured to rotate the pinion gear by exerting pressure on the rod part during the closing movement of the opening/closing cover and move the shutter to a position that exposes the cutter at the sheet discharge port.
2. A printer comprising:
- a main body case in which a sheet roll is installed;
  - a sheet discharge port from which a printed sheet of paper is discharged;
  - an opening/closing cover that opens and closes with respect to the main body case;
  - a cutter that is attached to the opening/closing cover and configured to cut the printed sheet of paper from the sheet roll; and
  - a cutter protection mechanism configured to move in correspondence with an opening movement or a closing movement of the opening/closing cover;
  - wherein the cutter protection mechanism is configured to expose the cutter at the sheet discharge port when the opening/closing cover is in a closed state and conceal the cutter when the opening/closing cover is in an open state,
  - wherein the cutter protection mechanism includes a shutter that is movably attached to the opening/closing cover,
  - a rack gear that is fixed to an end part of the shutter,
  - a pinion gear configured to mesh with the rack gear and rotate relative to the rack gear,
  - an urging part configured to urge the cutter or the pinion gear in a direction causing the shutter to cover the cutter, and
  - a rib that is formed on an inner side surface of the main body case,
  - wherein the pinion gear includes a rod part projecting from a peripheral surface of the pinion gear, and
  - wherein the rib is configured to rotate the pinion gear by exerting pressure on the rod part during the closing movement of the opening/closing cover and move the shutter to a position that exposes the cutter at the sheet discharge port.

\* \* \* \* \*