



US 20240134122A1

(19) **United States**

(12) **Patent Application Publication**
Frish

(10) **Pub. No.: US 2024/0134122 A1**

(43) **Pub. Date: Apr. 25, 2024**

(54) **PHOTONICS GRATING COUPLER AND METHOD OF MANUFACTURE**

Publication Classification

(71) Applicant: **Micron Technology, Inc.**, Boise, ID (US)

(51) **Int. Cl.**
G02B 6/30 (2006.01)
G02B 6/122 (2006.01)
G02B 6/124 (2006.01)
G02B 6/13 (2006.01)
G02B 6/132 (2006.01)
G02B 6/34 (2006.01)
G02B 6/36 (2006.01)

(72) Inventor: **Harel Frish**, Moshav Sede Moshe (IL)

(21) Appl. No.: **18/336,473**

(52) **U.S. Cl.**
CPC *G02B 6/30* (2013.01); *G02B 6/122* (2013.01); *G02B 6/124* (2013.01); *G02B 6/13* (2013.01); *G02B 6/132* (2013.01); *G02B 6/34* (2013.01); *G02B 6/3628* (2013.01); *B29D 11/00663* (2013.01)

(22) Filed: **Jun. 16, 2023**

Related U.S. Application Data

(60) Division of application No. 17/352,745, filed on Jun. 21, 2021, now Pat. No. 11,774,680, which is a continuation of application No. 16/669,937, filed on Oct. 31, 2019, now Pat. No. 11,041,990, which is a continuation of application No. 16/138,159, filed on Sep. 21, 2018, now Pat. No. 10,473,861, which is a continuation of application No. 15/664,975, filed on Jul. 31, 2017, now Pat. No. 10,209,449, which is a continuation of application No. 14/976,677, filed on Dec. 21, 2015, now Pat. No. 9,753,226, which is a continuation of application No. 13/829,893, filed on Mar. 14, 2013, now Pat. No. 9,239,432.

(57) **ABSTRACT**

A structure for coupling an optical signal between an integrated circuit photonic structure and an external optical fiber is disclosed as in a method of formation. The coupling structure is sloped relative to a horizontal surface of the photonic structure such that light entering or leaving the photonic structure is substantially normal to its upper surface.

100

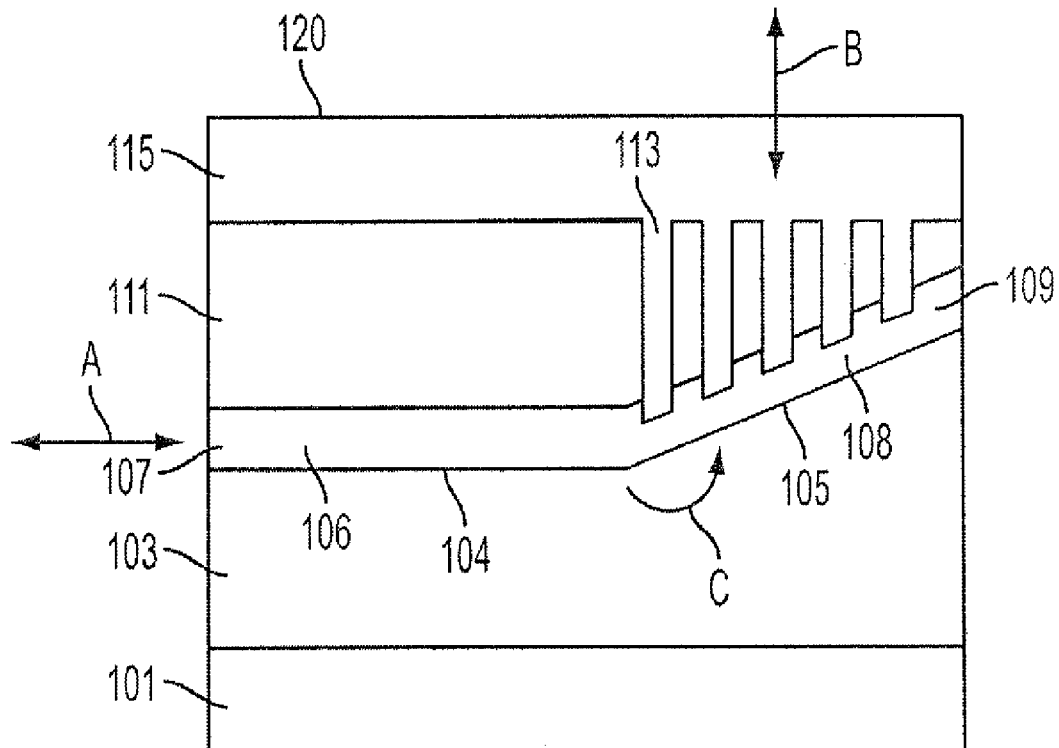

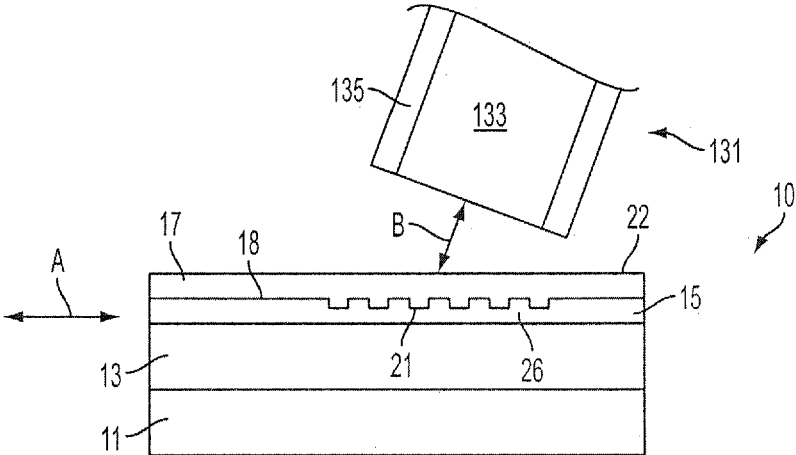

FIG. 1
PRIOR ART

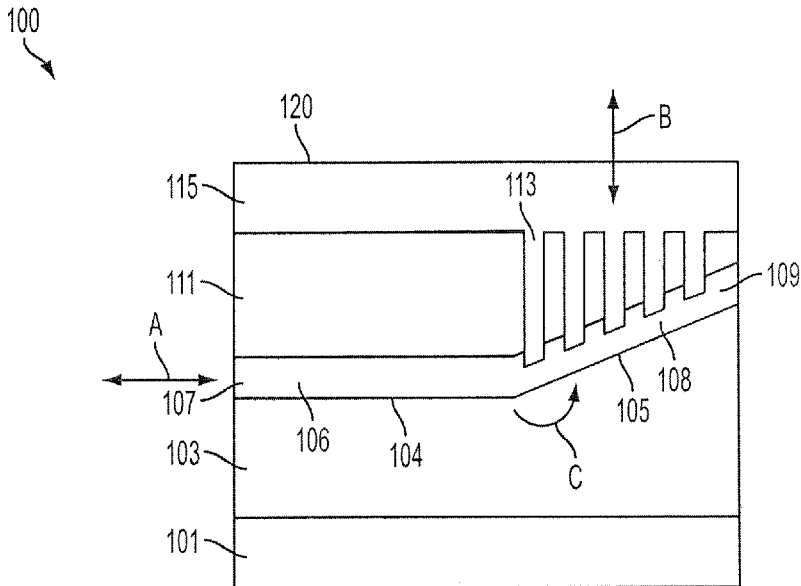

FIG. 2

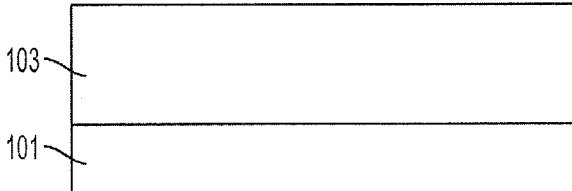

FIG. 3A

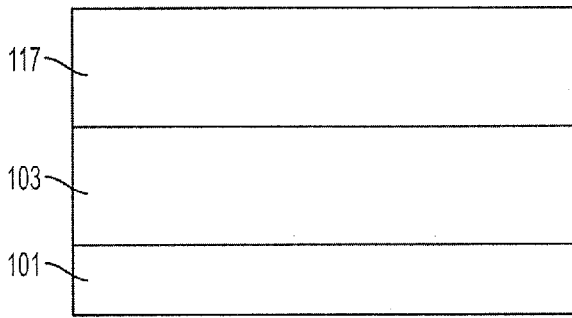

FIG. 3B

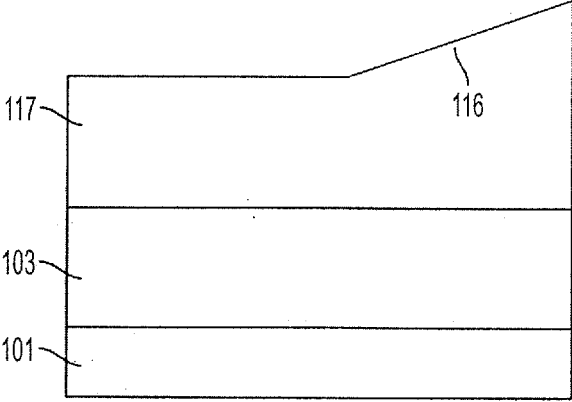

FIG. 3C

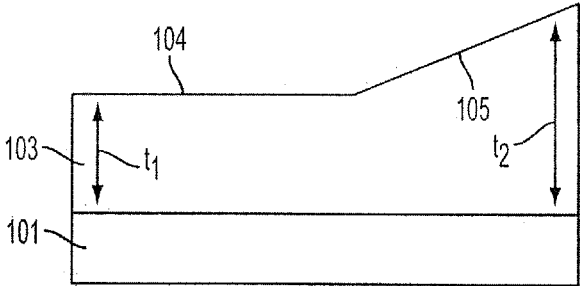

FIG. 3D

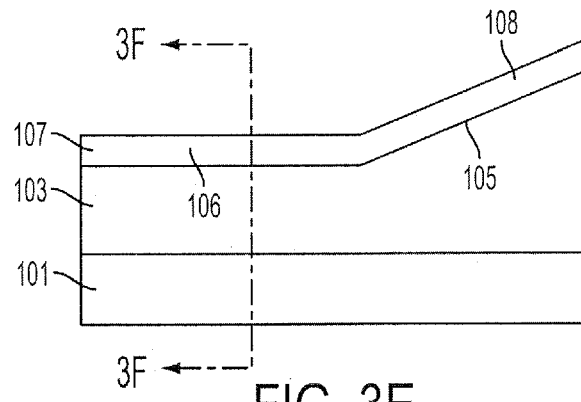

FIG. 3E

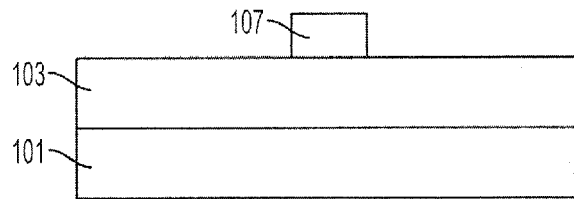

FIG. 3F

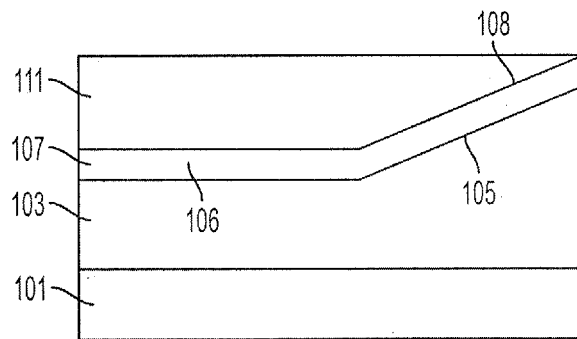

FIG. 3G

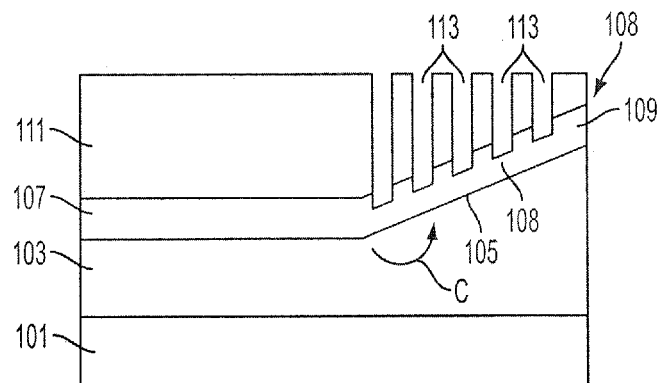

FIG. 3H

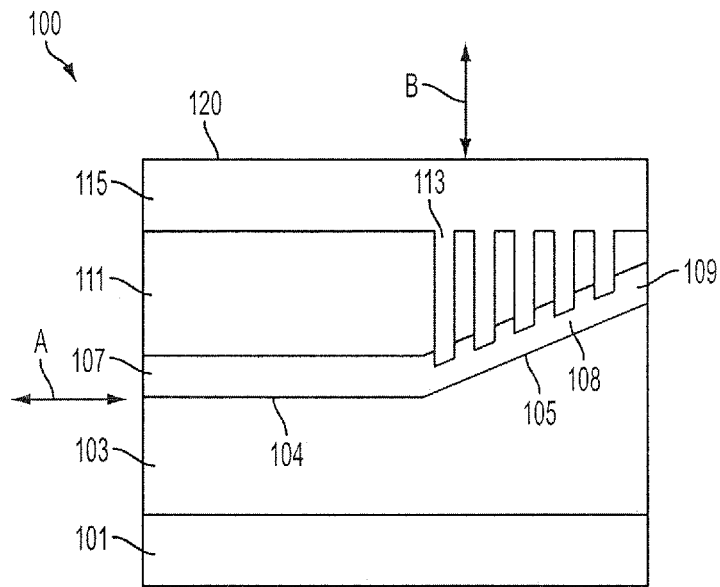

FIG. 3I

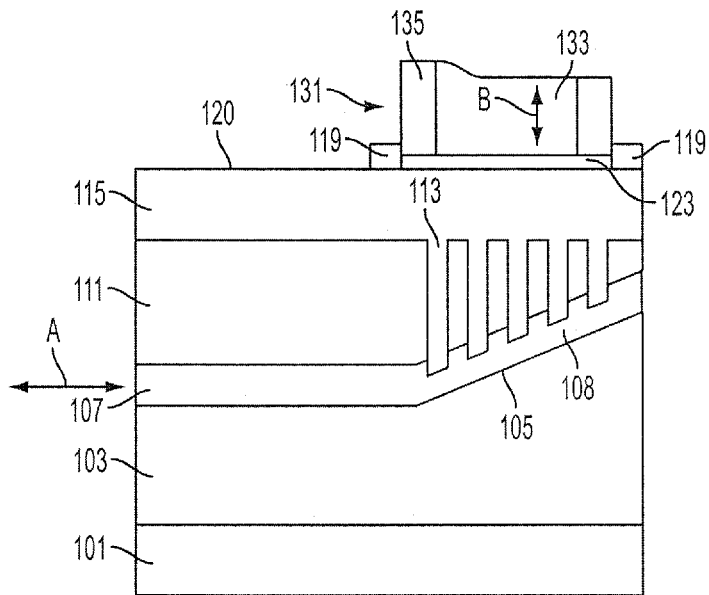

FIG. 4

PHOTONICS GRATING COUPLER AND METHOD OF MANUFACTURE

CROSS-REFERENCE TO RELATED APPLICATION

[0001] This application is a divisional of U.S. application Ser. No. 17/352,745, filed Jun. 21, 2021, which is a continuation of U.S. application Ser. No. 16/669,937, filed Oct. 31, 2019, now U.S. Pat. No. 11,041,990; which is a continuation of U.S. application Ser. No. 16/138,159, filed Sep. 21, 2018, now U.S. Pat. No. 10,473,861; which is a continuation of U.S. application Ser. No. 15/664,975, filed Jul. 31, 2017, now U.S. Pat. No. 10,209,449; which is a continuation of Ser. No. 14/976,677, filed Dec. 21, 2015, now U.S. Pat. No. 9,753,226; which is a continuation of U.S. application Ser. No. 13/829,893, filed Mar. 14, 2013, now U.S. Pat. No. 9,239,432; each of which is incorporated herein by reference.

GOVERNMENT RIGHTS

[0002] This invention was made with Government support under Agreement 9999404-12-0008 awarded by DARPA. The Government has certain rights in the invention.

FIELD OF THE INVENTION

[0003] Embodiments of the invention provide a structure for coupling optical signals between an integrated circuit photonics device, e.g., a waveguide, and an external optical fiber.

BACKGROUND OF THE INVENTION

[0004] Optical signal transmission may be used to communicate signals between separated integrated circuit chips to provide inter-chip connections and within components on the same integrated circuit chip to provide inter-chip connections. In many instances, it is necessary to couple an external optical fiber to a photonic device, e.g., a waveguide, of an integrated circuit photonics chip. Such coupling requires precise optical alignment between the optical fiber and the photonic device to maximize optical signal transmission between them.

[0005] However, coupling light into and out of a sub-micron integrated photonic device, such as a waveguide, with high efficiency is difficult because of the small waveguide mode size compared with that of an optical fiber.

[0006] Such optical coupling is made conventionally through a diffraction grating coupler provided on a planar upper surface of a waveguide which changes the direction of an optical signal passing through the waveguide from being generally parallel to the running length of waveguide to a direction which is out of the waveguide.

[0007] FIG. 1 illustrates in cross section an example of a prior art grating coupler. An integrated circuit photonic structure 10 is provided which has a silicon-on-insulator (SOI) substrate having a silicon base 11, a buried oxide (BOX) 13, typically formed of silicon dioxide, formed over silicon base 11, and a silicon fabrication material 26, which is formed into a waveguide core 15. The BOX 13 provides a lower cladding for the silicon waveguide core 15 and a further oxide material 17, which has a flat upper surface 22, is provided as side and an upper cladding for the waveguide core 15. A grating coupler 21 is formed in the upper surface 18 of the waveguide core 15 to direct light passing between

the waveguide core 15 and an optical fiber 131. The optical fiber 131 has a core 133 and outer cladding 135.

[0008] As shown, light entering into or exiting from the grating coupler 21 in the direction of arrows A is angled along optical axis B relative to the upper surface 22 of upper cladding 17. This angling of light along axis B is an inherent characteristic of grating coupler 21. Depending on the design of the grating coupler 21, including materials used, the optical axis B is at an angle in the range of about 8 to about 12 degrees from a direction normal to the upper surface 22 of photonic structure 10. As a result, if an optical fiber 131 is arranged to be normal to the upper surface of the photonic structure there is a considerable optical signal power loss, as much as 50%, between the grating coupler 21 and optical fiber 131. Thus, to obtain maximum efficiency in the transfer of light between the grating coupler 21 and optical fiber 131, the optical fiber 131 must, as shown, also be angled by a like amount relative to the upper surface 22 of the photonic structure 10. This complicates packaging of the photonic structure 10 as a mechanical angled coupling must be provided for the optical fiber 131. Moreover, the connection between the angled optical fiber 131 and photonic structure 10 typically requires an active alignment system to ensure alignment of the optical fiber 131 to the photonic structure 10 along optical axis B. This adds costs and complexity to the packaging of the photonic structure 10.

[0009] What is needed is a grating coupler and method of formation which provides an optical signal which is emitted to or received by an optical grating coupler in a direction substantially normal to the upper surface 22 of the photonic structure 10 to facilitate mechanical coupling with an optical fiber 131.

BRIEF DESCRIPTION OF THE DRAWINGS

[0010] FIG. 1 illustrates in cross-section a prior art arrangement of a photonic structure with an optical fiber;

[0011] FIG. 2 illustrates in a cross-section an embodiment of the invention;

[0012] FIGS. 3A-3I illustrate in cross-section one embodiment of a method for forming the FIG. 2 embodiment; and,

[0013] FIG. 4 illustrates in cross-section the coupling of the FIG. 2 embodiment with an external optical fiber.

DETAILED DESCRIPTION OF THE INVENTION

[0014] Embodiments described herein provide a grating coupler for an integrated photonic structure, and a method of its formation, which achieves a light coupling into and out of the photonic structure in a direction which is substantially normal to an upper surface of the photonic structure. In the context of this application substantially normal encompasses normal and a deviation of no more than 2 degrees from normal. As a result, assembly of the integrated circuit with an external light fiber can be facilitated, without requiring an active alignment structure between the two.

[0015] FIG. 2 illustrates in cross-section one embodiment of an integrated photonic structure 100 which has an optical axis B between a grating coupler 109 and an external fiber (FIG. 4) in a direction substantially normal to an upper surface 120 of the photonic structure 100. It comprises a substrate 101, for example a silicon substrate, and a lower cladding material 103 of an oxide, for example, silicon

dioxide. The lower cladding material **103** is provided with a generally horizontal portion having a horizontal upper surface **104** and an upwardly sloping portion having an upwardly sloping upper surface **105**. The photonic structure **100** further comprises a waveguide core **107** formed of, for example, silicon provided over the lower cladding material **103**. The waveguide core **107** has a horizontal portion **106** and an upwardly sloping portion **108**. The silicon used for waveguide core **107** can be polycrystalline silicon, single crystal silicon or amorphous silicon. The slope of upper surface **105** of lower cladding material **103** is at an angle C within the range of about 8 degrees and about 12 degrees relative to the horizontal upper surface **104** of the lower cladding material **103**, and also relative to an upper surface of horizontal portion **106** of waveguide core **107**, and also relative to an upper surface **120** of photonic structure **100**. The exact angle C is dependent on the design of grating coupler **109** and materials used, as described below.

[0016] An upper cladding material **111**, formed of for example, an oxide, e.g., silicon dioxide, or of silicon nitride, is provided over and around the sides of waveguide core **107**. The upper cladding material **111** has a series of grooves **113** therein over the upwardly sloping portion **108** of the waveguide core **107**. The grooves **113** extend into an upper surface of, but not through, the upwardly sloping portion **108** of the waveguide core **107** to form a sloped grating coupler **109**. The grating coupler **109** is also sloped by the angle C.

[0017] The photonic structure **100** further comprises an oxide material **115**, for example, silicon dioxide formed over an upper surface of upper cladding material **111** which extends into grooves **113** to complete, with cladding material **111** and oxide material **103**, a surrounding cladding for the waveguide core **107** and sloped grating coupler **109**. In one specific example, the slope angle C can be in the range of about 11.5 to about 12 degrees, the depth of the grooves in the upper surface of the sloped portion **108** of the waveguide core **107** may be in the range of about 270 nm to about 280 nm and the period of the grooves may be about 498 nm, although other slope angles C within the range of about 8 degrees to about 12 degrees can be used. Other depths and periods can also be used depending on the design of the grating coupler **109** and materials used.

[0018] Light transmitted along the horizontal portion **106** of waveguide **107** (i.e., along optical axis A) passes into the sloped grating coupler **109** which directs the light to exit an upper surface **120** of photonic structure **100** in a direction of optical axis B which is substantially normal to the upper surface **120**. Likewise, light entering into the photonic structure **100** at a location over grating **109** in a direction of optical axis B, will be directed by the grating **109** into the horizontal portion **106** of waveguide **107** along axis A. Thus, light enters or leaves the photonic structure **100** at an angle which is substantially normal to upper surface **120**, which minimizes optical signal power loss and facilitates assembly with an optical fiber **131** in the manner described below.

[0019] One manner in which the FIG. 2 structure can be fabricated is now described with reference to the cross-sectional views in FIGS. 3A through 3I.

[0020] FIG. 3A illustrates a substrate **101** having a flat upper surface and which may be of any suitable material for supporting an integrated photonic structure, including semiconductor materials such as silicon. A lower cladding material **103** is provided over substrate **101** and, depending on the

material used for waveguide core **107**, has an index of refraction lower than that of the waveguide core **107** material. If the waveguide core material is silicon, the lower cladding material **103** may be an oxide, for example, silicon dioxide. The lower cladding material **103** may be deposited by any known deposition technique, for example by PECVD or may be grown if the substrate **101** is a silicon substrate. The thickness of the deposited lower cladding material **103** may be in the range of about 1.5 μm to about 3.0 μm . The upper surface of the lower cladding material may be planarized, e.g., by CMP, to provide a flat surface which is parallel to the flat upper surface of substrate **101** to facilitate further fabrication.

[0021] FIG. 3B illustrates the deposition of a photoresist material **117** over the lower cladding material **103**. The deposited photoresist material **117** may be planarized, e.g., by CMP, such that the upper surface is flat. The deposited photoresist material **117** is then patterned using a known gray scale lithography technique for example, using high resolution 193 nm laser light and a graduated gray scale mask, to create the sloped upper surface **116** in the resist material **117** shown in FIG. 3C. A reactive ion dry etch (RIE), or a deep reactive ion dry etch (DRIE) is performed on the photoresist material **117** illustrated in FIG. 3C which consumes the photoresist material **117** and transfers the pattern of the upper surface of photoresist material **117** into the upper surface of lower cladding material **103**, as shown in FIG. 3D. After etching, the lower cladding material **103** has a horizontal upper surface **104** and an upwardly extending sloped upper surface **105**. The thickness t_1 of the lower cladding material **103** at the horizontal upper surface **104** can be in a range of from about 0.5 μm to about 1 μm and the thickness t_2 of the lower cladding material **103**, at the end of the sloped upper surface **105** can be in the range of about 1 μm to about 2 μm .

[0022] FIG. 3E illustrates deposition of a waveguide core **107** over the upper surface of the lower cladding material **103**. Waveguide core **107** may be formed of any suitable material for forming an optical waveguide, including silicon and may have a uniform thickness. Any suitable known deposition technique can be used to form waveguide core **107** including, PECVD and sputtering, among others. As illustrated in FIG. 3E, the waveguide core **107** has a horizontal portion **106** and an upwardly sloped portion **108** which corresponds to the sloped upper surface **105** of the lower cladding material **103**. The waveguide material **107** is initially deposited as a blanket layer which is then masked and etched to the upper surface of the lower cladding material **103** to form waveguide core **107**. FIG. 3F shows a ninety degree rotated cross sectional view of the FIG. 3E structure along the lines 3F-3F and the resultant waveguide core **107** after the masking and etching of the waveguide core blanket material.

[0023] Following formation of waveguide core **107**, and as illustrated in FIG. 3G, an upper cladding material **111**, which may be an anti-reflective coating, is then deposited over the waveguide core material **107**. The deposited upper cladding material **111** is planarized to have a flat surface which is substantially parallel to the flat surface of substrate **101** and the flat upper surface of the horizontal portion **106** of waveguide core **107**. Any suitable deposition technique can be used to deposit material **111** including PECVD. The upper cladding material **111** has an index of refraction lower than that of the waveguide core **107** material. For a silicon

waveguide core **107** the anti-reflective coating which provides the upper cladding material **111** can be silicon nitride, or an oxide such as silicon dioxide.

[0024] Next, as illustrated in FIG. 3H, the upper cladding material **111** is etched to form a plurality of parallel grooves **113** therein which extend not only through the upper cladding material **111** but also into an upper surface of the sloped portion **108** of the waveguide core **107**. The grooves **113** are vertically oriented relative to an upper surface of the horizontal portion **106** of waveguide core **107**. The plurality of grooves **113** extend into the upper surface of sloped portion **108** of the waveguide core **107** and form grating coupler **109**. The etching of grooves **113** may be performed by reactive ion etching, or other wet or dry etching technique. The bottom of the grooves **113** have a profile which matches the slope profile of the upper surface of sloped portion **108**. In one example, the grooves may extend into the upper surface of sloped portion **108** of the waveguide core **107** by an amount in the range of about 270 nm to about 280 nm. The grooves **113** may extend the entire width of the waveguide core **107**. In one example, the grooves **113** can also be spaced on a pitch of about 498 nm. However, other groove depths and periods, including non-uniform periods, can be used depending on the desired design of the grating coupler **109**, and materials used.

[0025] Next, as shown in FIG. 3I, additional cladding material such as an oxide material **115**, for example, silicon dioxide, is deposited to overcoat upper cladding material **111** and to fill in the grooves **113**. The upper surface **120** of oxide material **115** can be planarized such that it is parallel to the horizontal upper surface of **104** of the lower cladding material **103**. By filling in the grooves **113** with the oxide material **115**, the upper cladding for waveguide core **107** is complete such that a surrounding cladding for waveguide core **107** and grating coupler **109** is provided by lower cladding material **103**, upper cladding material **111**, and grooves **113** filled with oxide material **115**. As an option, the oxide material **115** can also be planarized to the upper surface of the upper cladding material **111** after grooves **113** are filled in which case the upper surface of the upper cladding material **111** provides the upper surface of the photonic structure **100**.

[0026] Grating coupler **109** formed on the sloped portion **108** of waveguide core **107** provides a direction change for light passing into or out of waveguide core **107** and into or out of the photonic structure **100** illustrated in FIG. 3I. The angle with which light enters or leaves the photonic structure **100** is at a direction substantially normal to an upper surface **120** of the photonic structure **100**. The angle is also substantially normal to materials in the photonic structure **100** including the horizontal portion of waveguide core **107**, and the upper surface of upper cladding material **111**. As noted, depending on the design of the grating coupler **109** and materials used, the slope angle C for grating **109** is in the range of about 8 degrees to about 12 degrees relative to upper surface **120**. Thus, the direction of light into or out of the grating coupler **109** is such that the angle between the direction of light paths A in the horizontal portion **106** of the waveguide core **107** and B into and out of the grating coupler (FIG. 2) is substantially normal, that is, at 90 degrees.

[0027] The precise angle C will be different for different physical characteristics of the grating coupler **109**, including materials used and location and spacing of the grooves **113**,

and materials used for the surrounding cladding. Accordingly, the exact slope angle for a particular grating coupler **109** within the range of about 8 degrees to about 12 degrees relative to the upper surface **120** can be determined in advance. One technique for determining the slope angle of a specific grating coupler **109** in advance is to first fabricate a horizontal grating coupler of the same materials and which has the same groove structure as a grating coupler **109** to be fabricated. The exit angle of light propagating through the horizontal grating coupler is measured for deviation from a direction normal to the upper surface of the waveguide core. This deviation angle is then used as the slope angle C in the grating coupler **109** fabricated as described above with reference to FIGS. 3A through 3I. In a second more preferred technique, the construction of the planar waveguide grating coupler is simulated by a computer and the deviation from normal of the light emitted by the simulated planar waveguide is determined and then used to set the slope angle C of the grating coupler **109** fabricated as described with reference to FIGS. 3A through 3I. For the grating coupler **109** having the materials, groove depth and groove pitch as described above, a slope angle of about 11.5 to about 12 degrees has been found suitable to produce an optical direction B of entry or exit of light in the wavelength range of 1525 nm to 1565 nm or 1180 nm to 1260 nm into or from the grating coupler **109**, which is substantially normal relative to upper surface **120**. In general, the grating period A follows the equation:

$$A = \frac{\lambda_o}{n_{eff} - n_{top} \text{Sine}\theta}$$

wherein n_{eff} is the effective refractive index of the waveguide core, n_{top} the refractive index of the cladding, λ_o is the free space wavelength of light passing through a waveguide, and θ is the emitting angle of light in a standard non sloped grating coupler. θ is the angle which is needed for the slope angle C to achieve a substantially normal emission from the sloped grating coupler **109**. Any change in etch depth, grating period, the duty cycle and slope, or combination of them, will change n_{eff} and affect the wavelength λ_o passing through the waveguide.

[0028] FIG. 4 shows the addition of a fiber alignment structure **119** to the upper surface of oxide material **115**. The alignment structure can be fabricated of any suitable material, for example, silicon dioxide and is provided such that an optical fiber **131** held by the alignment structure has an end face which sits squarely over the grating coupler **109**. For example, the alignment structure **119** can be fabricated as a collar for surrounding an optical fiber **131**. Since the angle of light entering or leaving the integrated circuit structure illustrated in FIG. 4 is substantially normal to the upper surface **120** of the photonic structure **100**, the optical fiber **131** can be easily fixed to the photonic structure **100** in a direction substantially normal to upper surface **120** by an optically transparent adhesive **123**. Thus, a simplified method for providing a photonic structure **100** which can be easily packaged for connection with an external optical fiber **131** and which does not need an active alignment structure is provided.

[0029] The various identified materials can be varied, as can the structure of the grating coupler **109** which is formed, either in the depth of the grooves **113** or period of the

grooves in order to accommodate specific wavelengths of light traveling through waveguide **107** and into or out of the photonic structure **100**. Also, while waveguide core **107** is described as being formed of silicon, which may be polycrystalline silicon, single crystalline silicon, or amorphous silicon, other materials known to be suitable for forming a waveguide core can also be used. Such other material include silicon nitride (Si₃N₄), silicon oxynitride (SiO_xN₄), silicon carbide (SiC), silicon germanium (Si_xGe_y), gallium arsenide (GaAs), aluminum gallium arsenide (AlGaAs), indium gallium arsenide (InGaAs), indium phosphor (InP), or other light transmission materials. In this list of materials x and y represent a positive integer. Likewise other materials than those discussed above can be used for cladding materials **103**, **111**, **115**, as long as the index of refraction of the material of the waveguide core **107** is higher than that of the surrounding upper and lower cladding materials **103**, **111**, **115**.

[0030] While embodiments of an optical grating coupler **109** and method of its formation have been described and illustrated, the invention is not limited by these embodiments. Also, while the photonic structure **100** is shown as having an upper surface **120** of a cladding material **115**, it should be apparent that additional light transmissive materials can be formed over the cladding material **115** as part of photonics integrated circuit. Also, as described, cladding material **115** can be planarized down to the upper surface of cladding material **111** such that the upper surface of cladding material **111** provides the upper surface of photonic structure **100**. In addition, while the sloped grating coupler **109** is described as being provided in a waveguide core **107**, it may also be provided in a light path of other photonic devices.

[0031] Accordingly, the invention as described above with reference to specific embodiments is not limited by the foregoing description but is only limited by the scope of the appended claims.

What is claimed is:

1. An integrated photonic structure, comprising:
 - a substrate;
 - a lower cladding material disposed over the substrate;
 - a waveguide core disposed over the lower cladding; and
 - an upper cladding material disposed over the waveguide core, the upper cladding material including a sloped grating coupler configured to redirect light into or out of the waveguide core in a direction normal to a planar upper surface of the integrated photonic structure.
2. The integrated photonic structure of claim **1**, wherein the sloped grating coupler comprises spaced grooves in the upper cladding material and in a sloped portion of the waveguide core.
3. The integrated photonic structure of claim **2**, wherein the spaced grooves are oriented substantially vertically relative to the planar upper surface of the integrated photonic structure.
4. The integrated photonic structure of claim **2**, wherein the spaced grooves extend into the sloped portion of the waveguide core by an amount ranging from about 270 nm to about 280 nm.
5. The integrated photonic structure of claim **2**, wherein the spaced grooves have a period of about 498 nm.

6. The integrated photonic structure of claim **2**, wherein the spaced grooves have a period A, wherein:

$$A = \frac{\lambda_o}{n_{eff} - n_{top} \text{Sine}\theta}$$

7. The integrated photonic structure of claim **1**, wherein the lower cladding has a horizontal portion and a sloped portion.

8. The integrated photonic structure of claim **1**, wherein the upper cladding material has an upper surface that is substantially parallel to the planar upper surface of the integrated photonic structure.

9. The integrated photonic structure of claim **1**, further comprising an oxide material disposed over the upper cladding material.

10. The integrated photonic structure of claim **9**, wherein the oxide material is further disposed in spaced grooves in the upper cladding material.

11. The integrated photonic structure of claim **9**, wherein the oxide material comprises the planar upper surface of the integrated photonic structure.

12. The integrated photonic structure of claim **1**, wherein the sloped grating coupler has a slope angle between 8 and 12 degrees relative to the planar upper surface of the integrated photonic structure.

13. The integrated photonic structure of claim **1**, wherein the sloped grating coupler is configured to redirect the light through a redirection angle of about 90 degrees.

14. The integrated photonic structure of claim **1**, further comprising a collar configured to surround a planar end of an optical fiber, the collar disposed upon the planar upper surface of the integrated photonic structure and vertically aligned with the sloped grating coupler.

15. The integrated photonic structure of claim **1**, wherein the waveguide core comprises polycrystalline silicon, single crystalline silicon, amorphous silicon, silicon nitride, silicon oxynitride, silicon carbide, silicon germanium, gallium arsenide, aluminum gallium arsenide, indium gallium arsenide, indium phosphor, or a combination thereof.

16. A method of making an integrated photonic structure, comprising:

- providing a substrate;
- disposing a lower cladding material over the substrate;
- disposing a waveguide core over the lower cladding; and
- disposing an upper cladding material over the waveguide core, the upper cladding material including a sloped grating coupler configured to redirect light into or out of the waveguide core in a direction normal to a planar upper surface of the integrated photonic structure.

17. The method of claim **16**, further comprising disposing an oxide material over the upper cladding material.

18. The method of claim **17**, further comprising disposing the oxide material in spaced grooves in the upper cladding material.

19. The method of claim **16**, further comprising disposing a collar configured to surround a planar end of an optical fiber upon the planar upper surface of the integrated photonic structure and vertically aligned with the sloped grating coupler.

* * * * *