



(11) **EP 4 261 514 A3**

(12) **EUROPEAN PATENT APPLICATION**

(88) Date of publication A3:
15.11.2023 Bulletin 2023/46

(43) Date of publication A2:
18.10.2023 Bulletin 2023/42

(21) Application number: **22213007.2**

(22) Date of filing: **13.12.2022**

(51) International Patent Classification (IPC):
G01L 9/00 (2006.01) G01L 19/04 (2006.01)
G01L 19/06 (2006.01) G01L 19/14 (2006.01)
G01L 21/30 (2006.01)

(52) Cooperative Patent Classification (CPC):
G01L 19/0636; G01L 9/0022; G01L 9/003;
G01L 9/008; G01L 19/04; G01L 19/0645;
G01L 19/142; G01L 19/149; G01L 21/30

(84) Designated Contracting States:
AL AT BE BG CH CY CZ DE DK EE ES FI FR GB
GR HR HU IE IS IT LI LT LU LV MC ME MK MT NL
NO PL PT RO RS SE SI SK SM TR
Designated Extension States:
BA
Designated Validation States:
KH MA MD TN

(30) Priority: **22.03.2022 JP 2022045867**

(71) Applicant: **Vacuum Products Corporation**
Kodaira-shi, Tokyo 187-0012 (JP)

(72) Inventor: **HOJOH, Hisao**
Musashino-shi, Tokyo (JP)

(74) Representative: **Wunderlich & Heim**
Patentanwälte
Partnerschaftsgesellschaft mbB
Irmgardstraße 3
81479 München (DE)

(54) **DIAPHRAGM PRESSURE GAUGE AND COMPOUND PRESSURE GAUGE**

(57) A diaphragm pressure gauge 10 includes: a structure 40 disposed under pressure to be measured (P_m); two diaphragms 20 attached to the structure so as to oppose each other; and a detection element 30 that is fixed to the two diaphragms to detect displacements of the two diaphragms. In each of the two diaphragms, when one of two surfaces is designated an opposing surface and the other surface is designated a non-opposing surface, the structure and the two diaphragms set a space faced by one of the opposing surface and the non-opposing surface as an airtight space 40A to be kept in a reference vacuum (P_r), and the other of the opposing surface and the non-opposing surface is subjected to the pressure to be measured.

FIG. 1

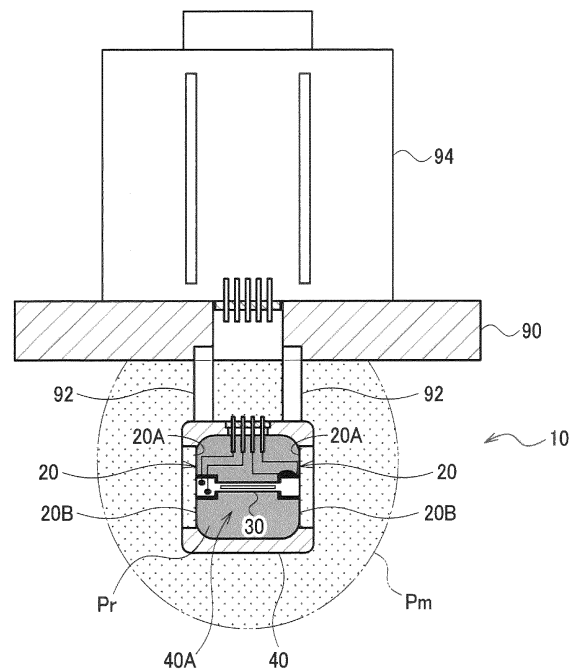

EP 4 261 514 A3



EUROPEAN SEARCH REPORT

Application Number

EP 22 21 3007

5

10

15

20

25

30

35

40

45

50

55

DOCUMENTS CONSIDERED TO BE RELEVANT			
Category	Citation of document with indication, where appropriate, of relevant passages	Relevant to claim	CLASSIFICATION OF THE APPLICATION (IPC)
X	US 2009/308168 A1 (MOTOYAMA HISAO [JP]) 17 December 2009 (2009-12-17)	1, 3, 4, 7	INV. G01L9/00 G01L19/04 G01L19/06 G01L19/14 G01L21/30
Y	* abstract * * paragraphs [0049], [0050] * * figures 1, 3 *	2-6, 8-10	
X	US 2020/232861 A1 (HOJOH HISAO [JP]) 23 July 2020 (2020-07-23)	1, 2, 7	
Y	* abstract * * paragraphs [0085], [0099] * * figure 8 *	2-6, 8-10	
Y	EP 3 779 384 A1 (ROSEMOUNT AEROSPACE INC [US]) 17 February 2021 (2021-02-17) * paragraph [0054] * * figure 2 *	5	
Y	JP H07 294355 A (NIPPON DENSO CO) 10 November 1995 (1995-11-10) * paragraph [0016] * * figure 3 *	6	TECHNICAL FIELDS SEARCHED (IPC)
Y	US 2021/096035 A1 (KELLY BRANDON J [US] ET AL) 1 April 2021 (2021-04-01) * paragraphs [0058], [0059] *	8-10	G01L
The present search report has been drawn up for all claims			
Place of search The Hague		Date of completion of the search 2 October 2023	Examiner Grewe, Clemens F.
CATEGORY OF CITED DOCUMENTS X : particularly relevant if taken alone Y : particularly relevant if combined with another document of the same category A : technological background O : non-written disclosure P : intermediate document		T : theory or principle underlying the invention E : earlier patent document, but published on, or after the filing date D : document cited in the application L : document cited for other reasons & : member of the same patent family, corresponding document	

3
EPO FORM 1503 03:82 (P04C01)



Application Number

EP 22 21 3007

5

CLAIMS INCURRING FEES

The present European patent application comprised at the time of filing claims for which payment was due.

10

Only part of the claims have been paid within the prescribed time limit. The present European search report has been drawn up for those claims for which no payment was due and for those claims for which claims fees have been paid, namely claim(s):

15

No claims fees have been paid within the prescribed time limit. The present European search report has been drawn up for those claims for which no payment was due.

20

LACK OF UNITY OF INVENTION

The Search Division considers that the present European patent application does not comply with the requirements of unity of invention and relates to several inventions or groups of inventions, namely:

25

see sheet B

30

All further search fees have been paid within the fixed time limit. The present European search report has been drawn up for all claims.

35

As all searchable claims could be searched without effort justifying an additional fee, the Search Division did not invite payment of any additional fee.

40

Only part of the further search fees have been paid within the fixed time limit. The present European search report has been drawn up for those parts of the European patent application which relate to the inventions in respect of which search fees have been paid, namely claims:

45

None of the further search fees have been paid within the fixed time limit. The present European search report has been drawn up for those parts of the European patent application which relate to the invention first mentioned in the claims, namely claims:

50

55

The present supplementary European search report has been drawn up for those parts of the European patent application which relate to the invention first mentioned in the claims (Rule 164 (1) EPC).



LACK OF UNITY OF INVENTION
SHEET B

Application Number

EP 22 21 3007

5

The Search Division considers that the present European patent application does not comply with the requirements of unity of invention and relates to several inventions or groups of inventions, namely:

10

1. claims: 1-4, 7

- Invention 1 according to claims 1-4 and 7 solves the problem of how to provide a more compact pressure sensor,

15

2. claim: 5

- Invention 2 according to claims 5 solves the problem of how to reduce the temperature influence on the pressure sensing,

20

3. claim: 6

- Invention 3 according to claims 6 solves the problem of how to reduce the influence of fluid comprising particles on the pressure measurement,

25

4. claims: 8-10

- Invention 4 according to claims 8-10 solves the problem of how to provide a compound pressure sensor.

30

35

40

45

50

55

ANNEX TO THE EUROPEAN SEARCH REPORT
ON EUROPEAN PATENT APPLICATION NO.

EP 22 21 3007

5 This annex lists the patent family members relating to the patent documents cited in the above-mentioned European search report.
The members are as contained in the European Patent Office EDP file on
The European Patent Office is in no way liable for these particulars which are merely given for the purpose of information.

02-10-2023

Patent document cited in search report	Publication date	Patent family member(s)	Publication date
US 2009308168 A1	17-12-2009	CN 101603870 A	16-12-2009
		CN 102589786 A	18-07-2012
		JP 2010019828 A	28-01-2010
		KR 20090129363 A	16-12-2009
		TW 201007151 A	16-02-2010
		US 2009308168 A1	17-12-2009
US 2020232861 A1	23-07-2020	CN 111712697 A	25-09-2020
		EP 3845881 A1	07-07-2021
		JP 6796352 B2	09-12-2020
		JP WO2020079773 A1	15-02-2021
		KR 20210080271 A	30-06-2021
		US 2020232861 A1	23-07-2020
		WO 2020079773 A1	23-04-2020
EP 3779384 A1	17-02-2021	BR 102019026238 A2	02-03-2021
		CA 3065019 A1	16-02-2021
		EP 3779384 A1	17-02-2021
		US 2021047939 A1	18-02-2021
JP H07294355 A	10-11-1995	NONE	
US 2021096035 A1	01-04-2021	CN 107110730 A	29-08-2017
		CN 111220321 A	02-06-2020
		DK 3227654 T3	30-05-2022
		EP 3227654 A2	11-10-2017
		EP 4033216 A1	27-07-2022
		JP 6670839 B2	25-03-2020
		JP 2018502305 A	25-01-2018
		KR 20170102553 A	11-09-2017
		SG 10202105319Q A	29-07-2021
		SG 11201704775Q A	28-07-2017
		TW 201634219 A	01-10-2016
		TW 202025222 A	01-07-2020
		TW 202201473 A	01-01-2022
		US 2016209288 A1	21-07-2016
		US 2019271607 A1	05-09-2019
		US 2021096035 A1	01-04-2021
WO 2016115232 A2	21-07-2016		