



(11) **EP 3 631 235 B1**

(12) **EUROPEAN PATENT SPECIFICATION**

(45) Date of publication and mention of the grant of the patent:
27.12.2023 Bulletin 2023/52

(21) Application number: **18728883.2**

(22) Date of filing: **01.06.2018**

(51) International Patent Classification (IPC):
F16F 9/46^(2006.01)

(52) Cooperative Patent Classification (CPC):
F16F 9/466

(86) International application number:
PCT/EP2018/064515

(87) International publication number:
WO 2018/220200 (06.12.2018 Gazette 2018/49)

(54) **ELECTRONICALLY CONTROLLED VALVE FOR A SHOCK ABSORBER**

ELEKTRONISCH GESTEUERTES VENTIL FÜR EINEN STOSSDÄMPFER

VANNE À COMMANDE ÉLECTRONIQUE POUR UN AMORTISSEUR DE CHOCS

(84) Designated Contracting States:
AL AT BE BG CH CY CZ DE DK EE ES FI FR GB GR HR HU IE IS IT LI LT LU LV MC MK MT NL NO PL PT RO RS SE SI SK SM TR

(30) Priority: **01.06.2017 EP 17174115**

(43) Date of publication of application:
08.04.2020 Bulletin 2020/15

(73) Proprietor: **Öhlins Racing AB**
194 27 Upplands Väsby (SE)

(72) Inventor: **LINDBLAD, Geir**
195 31 Märsta (SE)

(74) Representative: **AWA Sweden AB**
P.O. Box 665
831 27 Östersund (SE)

(56) References cited:
EP-A2- 0 322 608 US-A1- 2016 200 163
US-A1- 2017 082 169

EP 3 631 235 B1

Note: Within nine months of the publication of the mention of the grant of the European patent in the European Patent Bulletin, any person may give notice to the European Patent Office of opposition to that patent, in accordance with the Implementing Regulations. Notice of opposition shall not be deemed to have been filed until the opposition fee has been paid. (Art. 99(1) European Patent Convention).

Description

Background

- 5 **[0001]** Some modern shock absorbers are provided with electronically controlled valves for dynamically adjusting the damping properties of the shock absorber by adjusting the throughput of the valve.
- [0002]** Some known electrically controllable valves comprise a needle valve controlling fluid flow through the valve. Larger fluid pressures increase forces on the needle, which in turn leads to the need of a stronger actuator to control movement of the needle in order to open or close the valve.
- 10 **[0003]** It is generally advantageous to provide small valves for example in order to reduce the size of the dampers and to save cost.
- [0004]** A prior art valve is described in WO 2010/002314 A1. The valve comprises a needle valve controlled by an actuator. A drawback of the valve is that the actuator is slow which makes adjustment of the position of the needle slow. Moreover, document US 2017/082169 A1 describes a valve according to the preamble of claim 1.
- 15 **[0005]** Hence, there is a need for an electrically controlled valve which quicker reacts to control signals to quickly adapt the damping characteristics of the shock absorber comprising the valve. Also, there is a need for a smaller and less expensive valve.

Summary of the invention

- 20 **[0006]** Accordingly, a first aspect of the invention relates to an improved valve for a shock absorber mitigating the above-mentioned shortcomings of the prior art valves. The valve comprises a housing insertable into a first chamber of the shock absorber. The housing is provided with a portion forming a piston holder configured to extend along a central longitudinal axis of the first chamber. A piston is provided on the piston holder and configured to separate the inner
- 25 volume of the first chamber into a second chamber and a third chamber. The piston comprises a primary fluid channel fluidly connecting the second and third chambers to allow for a primary fluid flow between the second and third chambers. The piston holder comprises a secondary fluid channel fluidly connecting the second and third chambers to provide for a secondary fluid flow between the second and third chambers through said fluid channel. The valve further comprises a spool movable between an open position in which the spool allows secondary fluid flow through the secondary fluid
- 30 channel and a restricting position in which the spool at least partly restricts secondary fluid flow through the secondary fluid channel. The valve further comprises an electrically controlled actuator configured to move the spool between its open and restricting positions. The spool is guided in a corresponding portion of the secondary fluid channel of the piston holder for movement back and forth between the open and the closed positions. The piston holder is provided with one or more radial ports providing fluid inlets into the secondary fluid channel from the second chamber. The spool is
- 35 configured to throttle the secondary fluid flow at the fluid inlets of the piston holder by gradually blocking the fluid inlets of the secondary fluid channel with an outer surface of the spool upon movement of the spool from the open position towards the restricting position, and gradually unblocking the fluid inlets of the fluid channel upon movement of the spool from the restricting position towards the open position.
- [0007]** In such a valve, damping fluid is routed radially into the piston holder, thereby allowing the spool to cut-off fluid
- 40 flow according to the spool valve principle. By throttling the second fluid flow primarily at the inlets of the piston holder using the spool, rather than at the outlet, the pressure of the fluid contained within the piston holder and the spool is substantially constant independently of the fluid pressure in the second chamber of the first chamber. Upon unblocking of the inlet at opening of the spool, the pressure drop occurs mainly adjacent the inlet. The pressure drop should take place at a short flow path in order to make the shock absorber less prone to fading.
- 45 **[0008]** The one or more radial ports may in some embodiments be provided at an end portion of the piston holder, wherein the spool is provided with an inner fluid channel with a fluid inlet and a fluid outlet, the spool being configured such that the secondary fluid flow is routed through the inner fluid channel of the spool in use. Such a configuration of the valve is advantageous for fluid flows directed from the distal end portion of the piston holder inwards towards the base of the piston holder, typically during a compression stroke.
- 50 **[0009]** The end of the piston holder may be closed. The closed end of the piston holder promotes fluid flow through the radial inlet ports of the piston holder.
- [0010]** Specifically, the end of the piston holder may be closed by means of a plug provided with a substantially conical portion. The tip of the conical portion typically protrudes into the fluid channel of the spool. The conical portion of the plug guides fluid entering the valve thereby reducing turbulence and flow resistance through the valve. By providing the
- 55 conical portion as a part of a plug, production of the piston holder comprising the internal cone is simplified. Further, this design provides for a modular design using plugs with differently shaped cones for different valves/spools as required.
- [0011]** The base of the conical portion may have a smaller diameter than the inner diameter of the piston holder. Such a conical portion enables fluid to enter substantially radially into the piston holder and redirect along the piston holder

over a larger distance in a controlled manner, thereby reducing flow resistance and improving the reaction speed of the valve.

[0012] The fluid inlet opening of the spool may comprise a chamfered portion substantially parallel to the conical portion of the plug. The chamfered portion provides for a sharper distal edge of the spool and more distinct restriction of damper fluid flow.

[0013] The inlet of the spool may be provided through an end of the spool. With the provision of the inlet of the spool through an end of the spool, as opposed to a provision of the inlet as a radial hole through the wall of the spool, fluid flow and turbulence can be adjusted mainly by modifying the shape, position and number of inlets of the piston holder, since pressure drops spread around the inlet.

[0014] A pressure compensation chamber may be provided in the housing, said pressure compensation chamber being fluidly connected to the inner fluid channel of the spool by means of an auxiliary fluid channel.

[0015] The pressure compensation chamber enables pressure balancing of the spool to make the movement of the spool substantially pressure-independent. A pressure balanced spool enables use of a smaller actuator and/or a faster actuator since the actuator does not have to work as hard to overcome pressure acting on the spool.

[0016] The auxiliary fluid channel may be provided through the spool. By providing the auxiliary fluid channel through the spool, there is no need to machine a fluid channel in the housing, and thus different spool configurations can be used for one type of housing.

[0017] Alternatively, the auxiliary fluid channel may be provided in the wall of the piston holder. By providing the auxiliary fluid channel in the wall of the piston holder manufacturing of the spool is simplified.

[0018] The actuator may be a stepper motor. The stepper motor enables control of the position of the spool with no further parts, as opposed to using a solenoid which requires the spool to be biased against the force of the solenoid in order to allow control of the position of the spool.

[0019] The spool may be connected to the actuator by means of a shaft, and wherein the pressure compensation chamber is provided around the shaft. Providing the pressure compensation chamber around the shaft enables use of a simple and robust piston holder in one piece with a simple to machine inner channel/bore, whereas any extra balancing forces needed can be allocated to the portion surrounding the shaft, which is readily available for machining from the actuator-side of the housing anyways. This design of the valve is thus simple and robust.

[0020] The spool and the shaft may be cylindrical and the diameter of the shaft smaller than the diameter of the spool. The space around the shaft exposes surfaces of the spool suitable for pressure-compensation within the confines of the central bore of the piston holder. Thereby fewer machining steps are required for manufacturing of the valve, whilst the overall size and weight of the spool, as well as the valve, may be kept small.

[0021] The spool and/or the shaft may be configured such that a fluid pressure acting in the pressure compensation chamber forces the spool away from the open position towards the closed position. The pressure from the fluid in the pressure compensation chamber acts on surfaces of the spool directed so as to have a force component acting for pushing the spool in the described direction, thereby fully or partially balancing the forces caused by the fluid pressure in other portions of the valve acting on the spool for pushing the spool inwards in a direction from the closed position towards the open position.

[0022] The spool and/or the shaft may be configured such that fluid pressure acting on the spool generates a balanced force substantially not forcing the spool to move in any direction. A balanced spool enables use of smaller and/or faster stepper motors since less power is needed to control the position of the spool. For example, the diameter of the shaft can be varied to decrease the net force from the pressure compensation chamber on the spool by increasing the shaft diameter, and vice versa.

[0023] A sealing element may be provided between the shaft and the housing for isolating the pressure compensation chamber from a portion of the housing containing the actuator. The sealing element enables reliable closing of the pressure compensation chamber by surfaces of the housing, which in turn enables the net force on the spool created by the fluid pressure in the pressure compensation chamber to act in the desired direction. If the pressure compensation chamber would be a chamber within the spool itself, the net force acting on the spool would be zero.

[0024] The outlet openings of the piston holder may be sized larger than the inlet openings of the piston holder. Such configuration provides for restriction of fluid flow through the valve is mainly at the inlet of the piston holder and not at the outlet of the piston holder.

Brief description of drawings

[0025]

Fig. 1 shows a perspective view of a shock absorber for a front fork or a vehicle, such as a motorcycle, shown with an electrical connector at the upper portion of the shock absorber for control of the damping characteristics of the shock absorber.

Fig. 2 shows a cross-sectional view of the shock absorber also shown in Fig. 1. The shock absorber comprises a valve according to a first embodiment of the invention.

Fig. 3 shows an enlarged detail view of a first portion A of the shock absorber also shown in Figs. 1 and 2.

Fig. 4 shows an enlarged detail view of a second portion B of the shock absorber also shown in Figs. 1, 2 and 3.

5 Fig. 5 is a cross sectional view in plane P1 showing an enlarged detail of the outlets of the inner fluid channel of the spool, and of the outlets of the secondary fluid passage of the piston holder.

Fig. 6 shows a perspective view of a shock absorber for a rear swing arm of a vehicle, such as a motorcycle, shown with two valves according to the invention, and respective electrical connectors shown for illustrative purposes as detached from at the respective valves, although they in reality are connected to each respective valve.

10 Fig. 7 show a cross-sectional view in perspective of a portion of a valve according to a first embodiment of the invention fitted within a first chamber of the shock absorber of Figs. 1-4. Note that the actuator is not shown, as it is outside the bounds of the figure, but the actuator is shown in Figs. 2 and 3 - enlarged portion A.

Fig. 8 show a cross-sectional view in perspective of a valve according to a second embodiment of the invention fitted within a first chamber of the rear shock absorber of Fig. 6. Note that the actuator is shown but not the piston normally attached to the piston holder in the left hand portion of Fig. 8. However, the piston has the same basic design and function as that of Fig. 7.

Fig. 9 shows a side view of a damper provided with a valve according to a third embodiment of the invention.

Fig. 10 shows the damper of Fig. 9 in cross-section.

20 Fig. 11 shows the valve according to the third embodiment of the invention. As shown, the inlet of the secondary fluid channel is provided at an inner portion of the piston holder for controlling rebound flow of the damper fluid. In this embodiment, the secondary fluid flow is not routed through the spool but directly through the secondary fluid channel of the piston holder.

Fig. 12 shows an alternative embodiment of the valve shown in Fig. 11, further provided with a pressure compensation system for balancing fluid forces acting on the spool.

25 **[0026]** The following reference numerals are used throughout the description and claims. It should be noted that reference numeral 1 refers generally to the inventive valve, whereas 1a and 1b refer directly to each respective one of the two disclosed embodiments.

30	1	valve	13	electrically controlled actuator
	2	shock absorber	14	inner fluid channel of spool
	3	housing of valve	15	inlet of inner fluid channel of spool
35	4	first chamber of shock absorber	16	outlet of inner fluid channel of spool
	5	piston holder	17	end portion of piston holder
	6	central longitudinal axis of first chamber	18	fluid inlets
	7	piston	19	pressure compensation chamber
40	8	first chamber	20	auxiliary fluid channel
	9	second chamber	21	shaft
	10	primary fluid channel (of piston)	22	primary fluid flow
45	11	secondary fluid channel (of piston holder)	23	secondary fluid flow
	12	spool		

Detailed description

50 **[0027]** The disclosed embodiments will hereinafter be described in more detail with reference to the accompanying drawings in which several embodiments of the invention are shown. However, the invention may be embodied in many different forms and should not be construed as limited to the embodiments set forth herein. Rather, these embodiments are provided by way of example so that this disclosure will be thorough and complete, and will fully convey the scope of the invention to those skilled in the art. Like numbers refer to like elements throughout the description.

55 **[0028]** A shock absorber 2a comprising a valve according to a first embodiment of the invention is shown in Figs. 1-4 and 6. A valve according to a second embodiment of the invention is shown in Figs. 5 and 7.

[0029] The shock absorber 2a of Figs 1-4 is typically used for damping the movement of a front wheel of a motorcycle,

although other uses are possible. The damper uses a known twin tube design to route damping fluid during compression and rebound stroke of the shock absorber past one or more valves controlling fluid flow in the damper. The inventive valve is shown in more detail in Figs. 4 and 6.

[0030] The valve 1 comprises a housing 3 inserted into a first chamber 4 of the shock absorber 2.

[0031] The first chamber may in some embodiment correspond to the working chamber of the shock absorber. In other embodiments, the first chamber may correspond to an auxiliary chamber in fluid connection with the working chamber of the shock absorber, such as a space formed in an upper portion of the housing of the shock absorber as shown in Fig. 6. In other embodiments, the first chamber may be some other chamber of the shock absorber, through which damping fluid is routed in use.

[0032] The housing 3 is provided with a portion forming a piston holder 5 configured to extend along a central longitudinal axis 6 of the first chamber 4. A piston 7 is provided on the piston holder 5 and configured to separate the inner volume of the first chamber 4 into a second chamber 8 and a third chamber 9. The piston 7 comprises a primary fluid channel 10 fluidly connecting the second 8 and third 9 chambers to allow for a primary fluid flow 22 between the second 8 and third 9 chambers. The piston holder 5 comprises a secondary fluid channel 11 fluidly connecting the second 8 and third 9 chambers to provide for a secondary fluid flow 23 between the second 8 and third 9 chambers through said secondary fluid channel 11. The valve 1 further comprises a spool 12 movable between an open position in which the spool 12 allows secondary fluid flow through the secondary fluid channel 11 and a restricting position in which the spool 12 at least partly restricts secondary fluid flow through the secondary fluid channel 11.

[0033] The primary fluid flow is controlled by the fluid resistance characteristic of the piston 7, such as the size and number of holes defining the fluid channels of the piston, and optional provision of one or more shims covering the holes. The disclosed valve 1a of the first embodiment comprises a number of holes distributed around the piston and a shim stack covering the holes. A similar piston arrangement is provided for other embodiments of the inventive valve.

[0034] In order to further control damping fluid flow through the valve, the secondary fluid flow is adjustable by movement of the spool 12 between said open and restricting positions. In the open position, the valve is preferably fully open such that a larger secondary fluid flow is enabled. In the restricting position of the spool, the flow path of the secondary fluid flow is reduced by the spool, such that only a smaller fluid flow is allowed. In some embodiments, the spool in its restricting position fully blocks the secondary fluid flow.

[0035] In order to control the movement of the spool 12, the valve 1 comprises an electrically controlled actuator 13. In the embodiments of Figs. 1-7, the actuator is provided at an end portion A of the damper as illustrated in Fig. 3. By providing the actuator 13 at an end portion of the damper, electric cables need not be routed far through the damper to reach the actuator. In other embodiments, the actuator could be arranged further into the damper with cables routed to the actuator through the damper.

[0036] The actuator 13 is configured to move the spool 12 between its open and its restricting positions. The spool 12 is guided in a corresponding portion of the secondary fluid channel 11 of the piston holder 5 for movement between the open and the closed positions, typically a movement back and forth between various intermediate positions as governed by the actuator to vary fluid resistance of the valve. In the embodiments of Figs. 1-7, the piston holder has a substantially cylindrical shape, typically manufactured by turning. Also, the secondary fluid channel is made by drilling, and thus has a hole shape matching a cylindrical outer surface of the spool. In other embodiments, the secondary fluid channel may instead have some other cross-sectional shape, such as one with elliptical cross-section, wherein the spool would have a corresponding shape with an elliptical cross-section. In any case, the spool has to be movable between its open and restricting positions, and has to seal against the surrounding inner surface of the secondary fluid channel, such that the secondary fluid flow is routed through the spool rather than leaking past the spool in-between the spool and the piston holder, around the spool.

[0037] Thus, the spool 12 is provided with an inner fluid channel 14 with a fluid inlet 15 and a fluid outlet 16. The spool 12 is configured such that the secondary fluid flow is routed through the inner fluid channel 14 of the spool 12 in use. An end portion 17 of the piston holder 5 is provided with one or more radial ports providing fluid inlets 18 into the fluid channel 11 from the second chamber 8. The spool 12 is configured to throttle the secondary fluid flow at the fluid inlets 18 of the piston holder 5 by gradually blocking the fluid inlets 18 of the secondary fluid channel 11 with the cylindrical, or otherwise shaped, outer surface of the spool 12 upon movement of the spool 12 from the open position towards the restricting position, and gradually unblocking the fluid inlets 18 of the fluid channel 11 upon movement of the spool 12 from the restricting position towards the open position. As shown in Fig. 5, the outlets of the inner fluid channel of the spool are surrounded by a continuous space formed by the six holes forming the outlets of the secondary fluid passage of the piston holder. Since fluid can flow between the inner channel of the spool and the continuous space formed by the outlets, the spool is allowed to be arbitrarily rotated relative to the housing without negatively affecting fluid flow through the outlet. It should be noted that for some embodiments the spool is allowed to rotate relative to the housing, whilst in other embodiments the spool is directly or indirectly prevented from rotating relative to the housing. The design choice is largely depending on the choice of actuator. The main considerations affecting design is if a captive or a non-captive stepper motor is used. For example, in embodiments in which a non-captive stepper motor is used, the spool

must be directly or indirectly prevented from rotating in order for the torque of the stepper motor to be able to feed the spool between its open and restricting positions. One means for preventing relative rotation between spool and housing is to provide a ball in mutual track of the spool and the housing.

5 [0038] As best shown in Figs. 6-7, the end of the piston holder 5 is closed by means of a plug. The plug is provided with a substantially conical portion with the tip of the conical portion protruding into the fluid channel 11 of the spool 12. The closed end of the piston holder routes fluid flow through the radial ports of the piston holder, in contrast to a piston holder with an open end, which would have allowed fluid flow also through an axial opening of the piston holder.

10 [0039] Alternatively, the closed end may be integrally formed with the rest of the piston holder, such as by drilling the secondary fluid channel from the actuator-end of the housing, only partly through the housing so that there is no need to plug the end. The conical portion of the plug could thus alternatively be machined as an integral portion of the housing rather than as a part of a plug, for example by milling. However, milling is not suitable and may not even be possible so far into the elongate piston holder from the actuator -end of the housing.

15 [0040] By using the plug to provide a closed end of the piston holder, manufacturing of the conical portion is made easier since the conical portion of the plug can be made by turning. Thus, by providing the conical portion as a part of a plug, production of the piston holder comprising the internal cone is thus simple and inexpensive. Further, this design provides for a modular design using plugs with differently shaped cones for different valves or intended characteristics of the valves on a case-by-case basis.

20 [0041] In the embodiments of Figs. 1-7, the base of the conical portion has a smaller diameter than the inner diameter of the piston holder. Such a cone enables fluid to enter substantially radially into the piston holder and redirect along the piston holder over a larger distance in a controlled manner, thereby reducing flow resistance and improving the reaction speed of the valve. In other embodiments, the cone could have the same diameter as the inner diameter of the piston holder.

25 [0042] The fluid inlet opening of the spool 12 comprises a chamfered portion substantially parallel to the conical portion of the plug. The chamfered portion provides for a sharper distal edge of the spool, which in turn provides for increased turbulence by the inlets adjusted by the spool. The inlet 15 of the spool 12 is provided through an end of the spool 12, substantially centrally along the longitudinal axis of the spool.

30 [0043] With the provision of the inlet of the spool through an end of the spool, as opposed to a provision of the inlet as a hole through the side wall of the spool, such as a radial hole, fluid flow and turbulence can be adjusted mainly by modifying the shape, position and number of inlets of the piston holder. Pressure drops spread around the inlet of the spool and damping fluid flow can easily be cut off by the continuous edge portion surrounding the inlet of the spool. Hence, no rotational alignment is needed between the radial inlets of the piston rod and the spool about the longitudinal axis of the spool since the inlet of the inner channel 14 of the spool is symmetric about the longitudinal axis of the spool, thereby providing increased freedom of positioning the radial ports/inlets of the piston holder.

35 [0044] As best shown in Figs. 6 and 7, a pressure compensation chamber 19 is provided in the housing 3, the pressure compensation chamber 19 is fluidly connected to the inner fluid channel 14 of the spool 12 by means of a fluid channel herein called auxiliary fluid channel 20. The pressure compensation chamber enables pressure balancing of the spool to make movement of the spool substantially pressure-independent. A pressure balanced spool enables use of a smaller actuator or a faster actuator since the actuator does not have to work as hard to overcome pressure acting on the spool. If no pressure compensation chamber would be used, an increase of the pressure inside the spool would lead to an increased net force acting on the spool to force it towards its open position. With the pressure compensation chamber, fluid inside the pressure compensation chamber will have the same pressure as fluid in contact with the secondary fluid channel such that the net force of the pressure acting on the secondary fluid channel can be compensated by forces by a force acting in the opposite direction. Hence, the pressure compensation chamber enables a total net force of the fluid in contact with the spool to be adjusted by altering the size and shape of the pressure compensation chamber. The specific configuration and positioning of the pressure compensation chamber and the auxiliary fluid channel can be varied within the scope of the invention, as would be understood by the skilled person.

40 [0045] The auxiliary fluid channel 20 is provided through the spool 12. By providing the auxiliary fluid channel through the spool, there is no need to machine a fluid channel in the housing, and thus different spool configurations can be used for one type of housing. Alternatively, the auxiliary fluid channel 20 could in other embodiments be provided in the wall of the piston holder 5, for example as a recess extending along the length of the spool, such that the auxiliary fluid channel is formed between the outside of the spool and the recess in the inner surface of the spool.

45 [0046] By providing the auxiliary fluid channel in the wall of the piston holder 5, manufacturing of the spool 12 is simplified. In the illustrated embodiments, the actuator is a stepper motor. The stepper motor enables control of the position of the spool with no further parts, as opposed to using a solenoid which requires the spool to be biased against the force of the solenoid in order to allow control of the position of the spool, for example using a spring. That said, the actuator could alternatively be a solenoid instead of a stepper motor.

50 [0047] The spool 12 is connected to the actuator 13 by means of a shaft 21. The shaft is an integral portion of the spool 12, but may in other embodiments contain separate parts joined to the spool 12 by any suitable means, such as

threads, press fit, punching or welding. In the first embodiment or Figs. 1-4 and 6, the spool 12 is connected to the actuator by means of a long shaft. The pressure compensation chamber 19 is provided around the shaft 21. In the disclosed embodiment, the pressure 15 compensation chamber is formed in a space formed between the cylindrical inner surface of the piston holder also forming the secondary fluid channel, i.e. the same bore. In other embodiments

where a larger balancing force from the pressure compensation chamber is needed, a larger diameter space may be formed outside the main bore forming the secondary fluid channel.

[0048] Providing the pressure compensation chamber around the shaft enables use of a simple and robust piston holder in one piece with a simple-to-machine inner channel/bore. Since the shaft connecting the spool 12 and the actuator has a smaller diameter than the spool 12, the net force of fluid pressure in the pressure compensation chamber of the spool 12 is directed such that it forces the spool 12 in a direction away from the actuator. The pressure from the damping fluid in the pressure compensation chamber acts on surfaces of the spool directed so as to have a force component acting for pushing the spool in the described direction, thereby fully or partially balancing the forces caused by the fluid pressure in other portions of the valve acting on the spool for pushing the spool inwards in a direction from the closed position towards the open position.

[0049] Hence, the spool 12 and the shaft 21 are configured such that fluid pressure acting on the spool 12 generates a balanced force substantially not forcing the spool 12 to move in any direction. A balanced spool enables use of a smaller and faster actuator/stepper motor since less power is needed to control the position of the spool.

[0050] A sealing element being an O-ring, is provided between the shaft 21 and the housing 3 for isolating the pressure compensation chamber 19 from other portions of the housing, such as a portion of the housing 3 in some embodiments containing the actuator 13.

[0051] Also, the outlet openings of the piston holder 5 are sized larger than the outlet openings of the spool 12 such that fluid flow through the valve is mainly restricted at the inlet of the piston holder and not at the outlet of the piston holder.

[0052] By restricting fluid flow through the valve mainly at the inlet of the spool, the behavior of the valve consistent and predictable.

[0053] Although less advantageous, the valve could in alternative embodiments be configured such that fluid flow is restricted evenly at the inlet and the outlet of the secondary fluid channel, or even mainly at the outlet of the secondary fluid channel.

[0054] The shock absorber 2b of Fig. 6 for a rear swing arm of a vehicle, such as a motorcycle, is provided with two valves 1b according to a second embodiment of the invention as shown in Fig. 7. The valve 1b functions in the same way as the valve 1/1a of the first embodiment described above and shown in Figs. 1-5 and 8. A difference is the shorter shaft connecting the actuator and the spool. It should also be noted that in fig. 8, the valve 1b is shown without the piston 7 mounted on the piston holder 5. However, a piston 7 is indeed provided also in this second embodiment of the invention and hence also a primary fluid flow 22. A further difference is the shape of the housing which in this second embodiment houses also the actuator but which in the first embodiment of Figs. 1-5 and 7 houses only other features of the invention, such as the secondary fluid channel and the spool.

[0055] A valve according to a third embodiment of the invention is shown in Figs. 9-11 with an alternative embodiment in Fig. 12 comprising a pressure compensation system with an auxiliary fluid channel 20 connecting a pressure compensation chamber 19 to the secondary fluid channel 11 through the spool 12. The valve 1c according to the third embodiment of the invention functions similar to the valve of the first two embodiments 1a, 1b described above, but is adapted for damper fluid flows in the opposite directions. As such, the secondary fluid flow is restricted at the opposite side of the piston as compared to the other two embodiments. The spool restricts the secondary fluid flow at the end portion of the spool and retracts the end portion to unrestrict the secondary fluid flow which then flows directly through the secondary fluid channel of the piston holder without being routed through the spool. As shown in Fig. 11, the restricting end of the spool is provided with a conical portion. The conical portion guides the secondary fluid flow 23 into the secondary fluid channel 11.

[0056] In the above described embodiments of the invention, the piston of the valve is static within the first chamber when the shock absorber works, i.e. when a primary piston, for example connected to a wheel of a motorcycle, is moved through a working chamber of the shock absorber in use. A shock movement of the primary piston causes a pressure increase in the first chamber, for example the working chamber, which in turn forces damping fluid through the inventive valve or valves of the shock absorber, whilst the piston of the valve remains static relative to the first chamber.

Claims

1. A valve (1) for a shock absorber (2),

wherein the valve (1) comprises
a housing (3) at least partly insertable into a first chamber (4) of the shock absorber (2),

wherein the housing (3) is provided with a portion forming a piston holder (5) configured to extend along a central longitudinal axis (6) of the first chamber (4),

wherein a piston (7) is provided on the piston holder (5) and configured to separate the inner volume of the first chamber (4) into a second chamber (8) and a third chamber (9),

wherein the piston (7) comprises a primary fluid channel (10) for fluidly connecting the second (8) and third (9) chambers to allow for a primary fluid flow between the second (8) and third (9) chambers,

wherein the piston holder (5) comprises a secondary fluid channel (11) for fluidly connecting the second (8) and third (9) chambers to provide for a secondary fluid flow between the second (8) and third (9) chambers through the secondary fluid channel (11),

characterised in that

the valve (1) further comprises a spool (12) movable between an open position in which the spool (12) allows secondary fluid flow through the secondary fluid channel (11) and a restricting position in which the spool (12) at least partly restricts secondary fluid flow through the secondary fluid channel (11),

wherein the valve (1) further comprises an electrically controlled actuator (13) configured to move the spool (12) between its open and restricting positions,

wherein the spool (12) is guided in a corresponding portion of the secondary fluid channel (11) of the piston holder (5) for movement back and forth between the open and the closed positions,

wherein the piston holder (5) is provided with one or more radial ports providing fluid inlets (18) into the secondary fluid channel (11) from the second chamber (8), and

wherein the spool (12) is configured to throttle the secondary fluid flow at the fluid inlets (18) of the piston holder (5) by gradually blocking the fluid inlets (18) of the secondary fluid channel (11) with an outer surface of the spool (12) upon movement of the spool (12) from the open position towards the restricting position, and gradually unblocking the fluid inlets (18) of the secondary fluid channel (11) upon movement of the spool (12) from the restricting position towards the open position.

2. A valve (1) according to claim 1, wherein the one or more radial ports are provided at an end portion (17) of the piston holder (5) and wherein the spool (12) is provided with an inner fluid channel (14) with a fluid inlet (15) and a fluid outlet (16), the spool (12) being configured such that the secondary fluid flow is routed through the inner fluid channel (14) of the spool (12) in use.
3. A valve (1) according to claim 2, wherein the end of the piston holder (5) is closed.
4. A valve (1) according to claim 3, wherein the end of the piston holder (5) is closed by means of a plug provided with a substantially conical portion with the tip of the conical portion protruding into the inner fluid channel (11) of the spool (12).
5. A valve (1) according to claim 4, wherein the base of the conical portion has a smaller diameter than the inner diameter of the piston holder (5).
6. A valve (1) according to any one of claims 4-5, wherein the fluid inlet opening of the spool (12) comprises a chamfered portion substantially parallel to the conical portion of the plug.
7. A valve (1) according to any one of claims 2-6, wherein the inlet (15) of the spool (12) is provided through an end of the spool (12).
8. A valve (1) according to any one of claims 2-7, wherein a pressure compensation chamber (19) is provided in the housing (3), said pressure compensation chamber (19) being fluidly connected to the inner fluid channel (14) of the spool (12) by means of an auxiliary fluid channel (20).
9. A valve (1) according to claim 8, wherein the auxiliary fluid channel (20) is provided through the spool (12).
10. A valve (1) according to any one of the preceding claims, wherein the actuator (13) is a stepper motor.
11. A valve (1) according to any one of the preceding claims, wherein the spool (12) is connected to the actuator (13) by means of a shaft (21), and wherein the pressure compensation chamber (19) is provided around the shaft (21).
12. A valve (1) according to claim 11, wherein the spool (12) and the shaft (21) are cylindrical and wherein the diameter

of the shaft (21) is smaller than the diameter of the spool (12).

13. A valve (1) according to any one of claims 11-12, wherein the spool (12) and/or the shaft (21) are configured such that a fluid pressure acting in the pressure compensation chamber (19) forces the spool (12) away from the open position towards the closed position.

14. A valve (1) according to any one of claims 11-13, wherein the spool (12) and/or the shaft (21) are configured such that fluid pressure acting on the spool (12) generates a balanced force substantially not forcing the spool (12) to move in any direction.

Patentansprüche

1. Ventil (1) für einen Stoßdämpfer (2),

wobei das Ventil (1) ein Gehäuse (3) umfasst, das zumindest teilweise in eine erste Kammer (4) des Stoßdämpfers (2) einsetzbar ist,

wobei das Gehäuse (3) mit einem Abschnitt versehen ist, der einen Kolbenhalter (5) bildet, der eingerichtet ist, um sich entlang einer zentralen Längsachse (6) der ersten Kammer (4) zu erstrecken,

wobei ein Kolben (7) auf dem Kolbenhalter (5) vorgesehen ist und eingerichtet ist, das Innenvolumen der ersten Kammer (4) in eine zweite Kammer (8) und eine dritte Kammer (9) zu trennen,

wobei der Kolben (7) einen primären Fluidkanal (10) zum Fluidverbinden der zweiten (8) und der dritten (9) Kammer umfasst, um einen primären Fluidstrom zwischen der zweiten (8) und der dritten (9) Kammer zu ermöglichen,

wobei der Kolbenhalter (5) einen sekundären Fluidkanal (11) zum Fluidverbinden der zweiten (8) und der dritten (9) Kammer umfasst, um einen sekundären Fluidstrom zwischen der zweiten (8) und der dritten (9) Kammer durch den sekundären Fluidkanal (11) bereitzustellen,

dadurch gekennzeichnet, dass

das Ventil (1) ferner einen Schieber (12) umfasst, der zwischen einer offenen Position, in der der Schieber (12) einen sekundären Fluidstrom durch den sekundären Fluidkanal (11) ermöglicht, und einer drosselnden Position, in der der Schieber (12) den sekundären Fluidstrom durch den sekundären Fluidkanal (11) zumindest teilweise drosselt, beweglich ist,

wobei das Ventil (1) ferner ein elektrisch gesteuertes Stellglied (13) umfasst, das eingerichtet ist, um den Schieber (12) zwischen seiner offenen und seiner drosselnden Position zu bewegen,

wobei der Schieber (12) in einem entsprechenden Abschnitt des sekundären Fluidkanals (11) des Kolbenhalters (5) für eine Hin- und Herbewegung zwischen der offenen und der geschlossenen Position geführt wird,

wobei der Kolbenhalter (5) mit einer oder mehreren radialen Öffnungen versehen ist, die Fluideinlässe (18) in den sekundären Fluidkanal (11) von der zweiten Kammer (8) bereitstellen, und

wobei der Schieber (12) eingerichtet ist, um den sekundären Fluidstrom an den Fluideinlässen (18) des Kolbenhalters (5) zu drosseln, indem er die Fluideinlässe (18) des sekundären Fluidkanals (11) mit einer Außenfläche des Schiebers (12) bei einer Bewegung des Schiebers (12) von der offenen Position in Richtung der drosselnden Position zunehmend blockiert und die Fluideinlässe (18) des sekundären Fluidkanals (11) bei einer Bewegung des Schiebers (12) von der drosselnden Position in Richtung der offenen Position zunehmend freigibt.

2. Ventil (1) nach Anspruch 1, wobei die eine oder mehreren radialen Öffnungen an einem Endabschnitt (17) des Kolbenhalters (5) vorgesehen sind und

wobei der Schieber (12) mit einem inneren Fluidkanal (14) mit einem Fluideinlass (15) und einem Fluidauslass (16) versehen ist, wobei der Schieber (12) derart eingerichtet ist, dass der sekundäre Fluidstrom im Gebrauch durch den inneren Fluidkanal (14) des Schiebers (12) geleitet wird.

3. Ventil (1) nach Anspruch 2, wobei das Ende des Kolbenhalters (5) geschlossen ist.

4. Ventil (1) nach Anspruch 3, wobei das Ende des Kolbenhalters (5) mittels eines Einsatzkörpers verschlossen ist, der mit einem im Wesentlichen konischen Abschnitt versehen ist, wobei die Spitze des konischen Abschnitts in den inneren Fluidkanal (14) des Schiebers (12) vorsteht.

5. Ventil (1) nach Anspruch 4, wobei die Basis des konischen Abschnitts einen kleineren Durchmesser hat als der Innendurchmesser des Kolbenhalters (5).

EP 3 631 235 B1

6. Ventil (1) nach einem der Ansprüche 4-5, wobei die Fluideinlassöffnung des Schiebers (12) einen abgeschrägten Abschnitt umfasst, der im Wesentlichen parallel zu dem konischen Abschnitt des Einsatzkörpers ist.
- 5 7. Ventil (1) nach einem der Ansprüche 2-6, wobei der Einlass (15) des Schiebers (12) durch ein Ende des Schiebers (12) vorgesehen ist.
8. Ventil (1) nach einem der Ansprüche 2-7, wobei in dem Gehäuse (3) eine Druckausgleichskammer (19) vorgesehen ist, wobei die Druckausgleichskammer (19) mittels eines Hilfsfluidkanals (20) mit dem inneren Fluidkanal (14) des Schiebers (12) fluidverbunden ist.
- 10 9. Ventil (1) nach Anspruch 8, wobei der Hilfsfluidkanal (20) durch den Schieber (12) hindurch vorgesehen ist.
10. Ventil (1) nach einem der vorhergehenden Ansprüche, wobei das Stellglied (13) ein Schrittmotor ist.
- 15 11. Ventil (1) nach einem der vorhergehenden Ansprüche, wobei der Schieber (12) mittels einer Welle (21) mit dem Stellglied (13) verbunden ist, und wobei die Druckausgleichskammer (19) um die Welle (21) herum vorgesehen ist.
12. Ventil (1) nach Anspruch 11, wobei der Schieber (12) und die Welle (21) zylindrisch sind und wobei der Durchmesser der Welle (21) kleiner ist als der Durchmesser des Schiebers (12).
- 20 13. Ventil (1) nach einem der Ansprüche 11-12, wobei der Schieber (12) und/oder die Welle (21) derart eingerichtet sind, dass ein Fluiddruck, der in der Druckausgleichskammer (19) wirkt, den Schieber (12) von der offenen Position weg in Richtung der geschlossenen Position drückt.
- 25 14. Ventil (1) nach einem der Ansprüche 11-13, wobei der Schieber (12) und/oder die Welle (21) derart eingerichtet sind, dass der Fluiddruck, der auf den Schieber (12) wirkt, eine ausgeglichene Kraft erzeugt, die den Schieber (12) im Wesentlichen nicht zwingt, sich in irgendeine Richtung zu bewegen.

30 Revendications

1. Soupape (1) pour un absorbeur de chocs (2),

dans laquelle la soupape (1) comprend
35 un boîtier (3) susceptible d'être inséré au moins partiellement dans une première chambre (4) de l'absorbeur de chocs (2),
dans laquelle le boîtier (3) est doté d'une portion formant un support de piston (5) configuré pour s'étendre le long d'un axe longitudinal central (6) de la première chambre (4),
dans laquelle un piston (7) est disposé sur le support de piston (5) et configuré pour séparer le volume intérieur
40 de la première chambre (4) en une deuxième chambre (8) et une troisième chambre (9),
dans laquelle le piston (7) comprend un canal de fluide primaire (10) destiné à raccorder fluidiquement les deuxième (8) et troisième (9) chambres pour permettre un écoulement de fluide primaire entre les deuxième (8) et troisième (9) chambres,
dans laquelle le support de piston (5) comprend un canal de fluide secondaire (11) destiné à raccorder fluidiquement les deuxième (8) et troisième (9) chambres afin d'assurer un écoulement de fluide secondaire entre les deuxième (8) et troisième (9) chambres par le biais du canal de fluide secondaire (11),
45 **caractérisée en ce que**
la soupape (1) comprend en outre une bobine (12) déplaçable entre une position ouverte dans laquelle la bobine (12) permet un écoulement de fluide secondaire à travers le canal de fluide secondaire (11) et une position de limitation dans laquelle la bobine (12) limite au moins partiellement l'écoulement de fluide secondaire à travers le canal de fluide secondaire (11),
dans laquelle la soupape (1) comprend en outre un actionneur (13) commandé électriquement, configuré pour déplacer la bobine (12) entre ses positions de limitation et ouverte fermée,
dans laquelle la bobine (12) est guidée dans une portion correspondante du canal de fluide secondaire (11) du support de piston (5) pour un mouvement de va-et-vient entre les positions ouverte et fermée,
55 dans laquelle le support de piston (5) est doté d'un ou de plusieurs orifices radiaux fournissant des entrées de fluide (18) dans le canal de fluide secondaire (11) à partir de la deuxième chambre (8), et
dans laquelle la bobine (12) est configurée pour étrangler l'écoulement de fluide secondaire au niveau des

EP 3 631 235 B1

entrées de fluide (18) du support de piston (5) en bloquant progressivement les entrées de fluide (18) du canal de fluide secondaire (11) avec une surface extérieure de la bobine (12) lors du déplacement de la bobine (12) de la position ouverte vers la position de limitation, et en débloquant progressivement les entrées de fluide (18) du canal de fluide secondaire (11) lors du déplacement de la bobine (12) à partir de la position de limitation vers la position ouverte.

- 5
2. Soupape (1) selon la revendication 1, dans laquelle les un ou plusieurs orifices radiaux sont disposés au niveau d'une portion d'extrémité (17) du support de piston (5) et dans laquelle la bobine (12) est dotée d'un canal de fluide intérieur (14) avec une entrée de fluide (15) et une sortie de fluide (16), la bobine (12) étant configurée de telle façon que l'écoulement de fluide secondaire est acheminé à travers le canal de fluide intérieur (14) de la bobine (12) utilisée.
- 10
3. Soupape (1) selon la revendication 2, dans laquelle l'extrémité du support de piston (5) est fermée.
- 15
4. Soupape (1) selon la revendication 3, dans laquelle l'extrémité du support de piston (5) est fermée au moyen d'un bouchon doté d'une portion substantiellement conique avec la pointe de la portion conique faisant saillie dans le canal de fluide intérieur (14) de la bobine (12).
- 20
5. Soupape (1) selon la revendication 4, dans laquelle la base de la portion conique présente un diamètre inférieur au diamètre intérieur du support de piston (5).
- 25
6. Soupape (1) selon l'une quelconque des revendications 4 à 5, dans laquelle l'ouverture d'entrée de fluide de la bobine (12) comprend une portion chanfreinée substantiellement parallèle à la portion conique du bouchon.
- 30
7. Soupape (1) selon l'une quelconque des revendications 2 à 6, dans laquelle l'entrée (15) de la soupape (12) est disposée à travers une extrémité de la bobine (12).
- 35
8. Soupape (1) selon l'une quelconque des revendications 2 à 7, dans laquelle une chambre de compensation de pression (19) est disposée dans le boîtier (3), ladite chambre de compensation de pression (19) étant reliée fluidiquement au canal de fluide intérieur (14) de la bobine (12) au moyen d'un canal de fluide auxiliaire (20).
- 40
9. Soupape (1) selon la revendication 8, dans laquelle le canal de fluide auxiliaire (20) est disposé à travers la bobine (12).
- 45
10. Soupape (1) selon l'une quelconque des revendications précédentes, dans laquelle l'actionneur (13) est un moteur pas à pas.
- 50
11. Soupape (1) selon l'une quelconque des revendications précédentes, dans laquelle la bobine (12) est raccordée à l'actionneur (13) au moyen d'un arbre (21), et dans laquelle la chambre de compensation de pression (19) est disposée autour de l'arbre (21).
- 55
12. Soupape (1) selon la revendication 11, dans laquelle la bobine (12) et l'arbre (21) sont cylindriques et dans laquelle le diamètre de l'arbre (21) est inférieur au diamètre de la bobine (12).
13. Soupape (1) selon l'une quelconque des revendications 11 à 12, dans laquelle la bobine (12) et/ou l'arbre (21) sont configurés de telle façon qu'une pression fluide agissant dans la chambre de compensation de pression (19) pousse la bobine (12) à distance de la position ouverte vers la position fermée.
14. Soupape (1) selon l'une quelconque des revendications 11 à 13, dans laquelle la bobine (12) et/ou l'arbre (21) sont configurés de telle façon qu'une pression fluide agissant sur la bobine (12) génère une force équilibrée ne poussant quasiment pas la bobine (12) à se déplacer dans une direction quelconque.

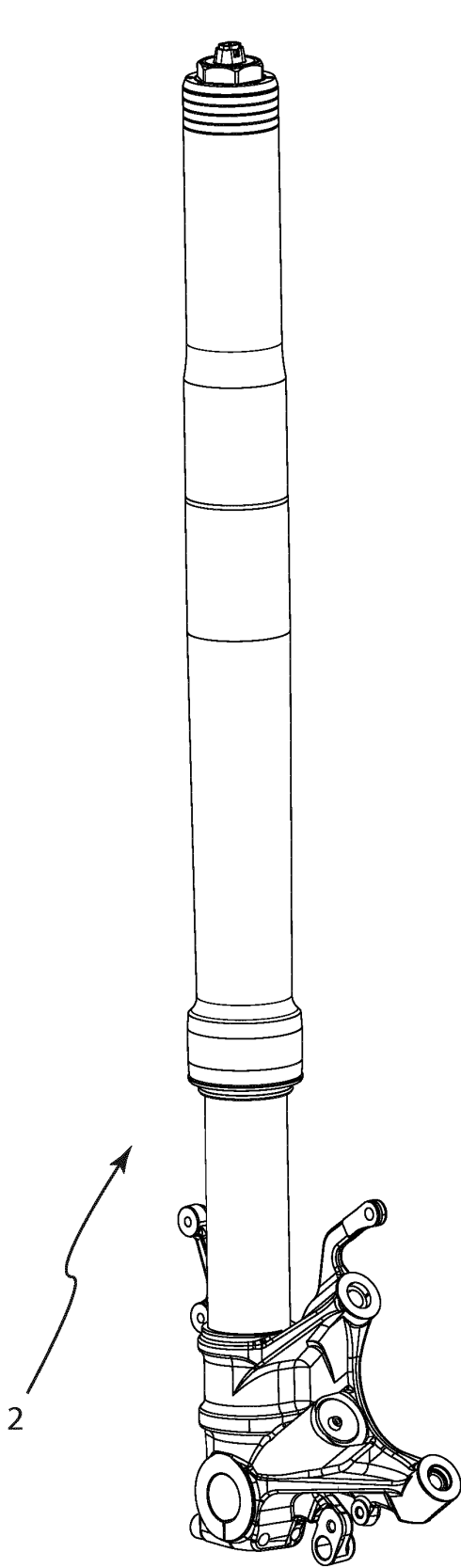

Fig. 1

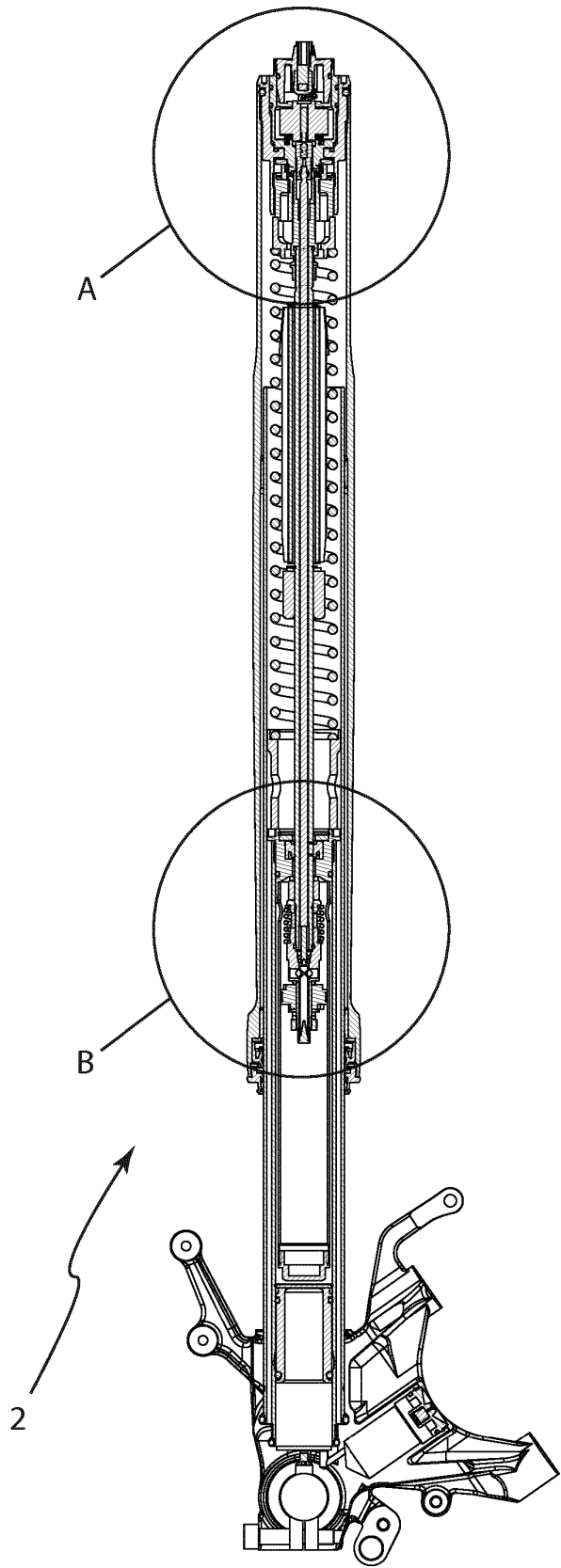

Fig. 2

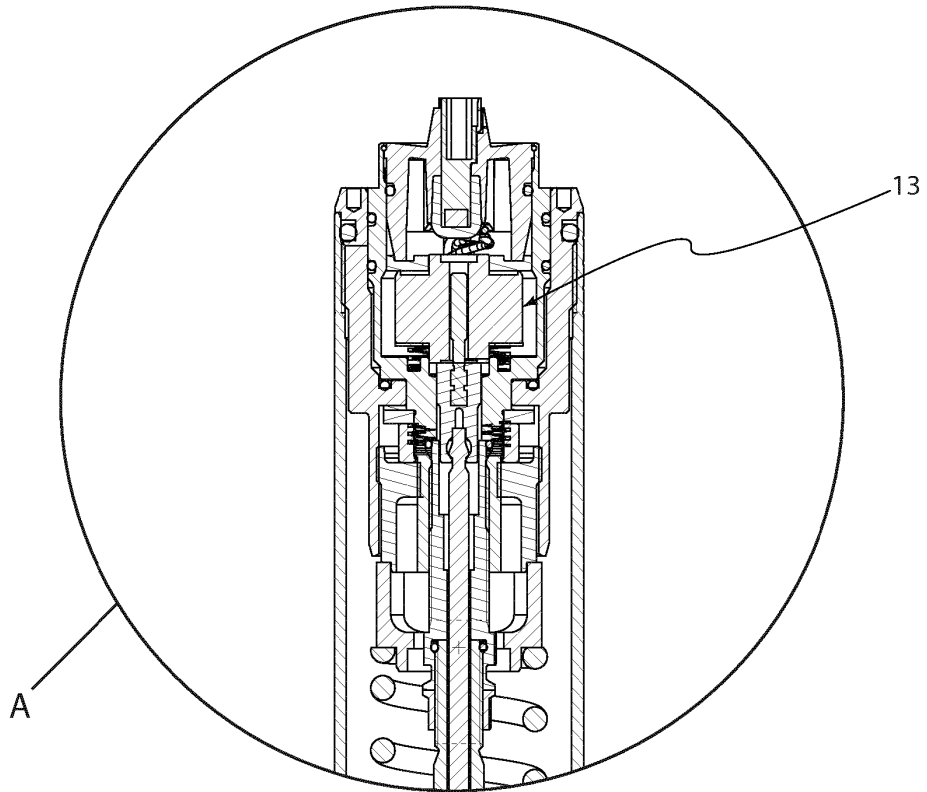

Fig. 3

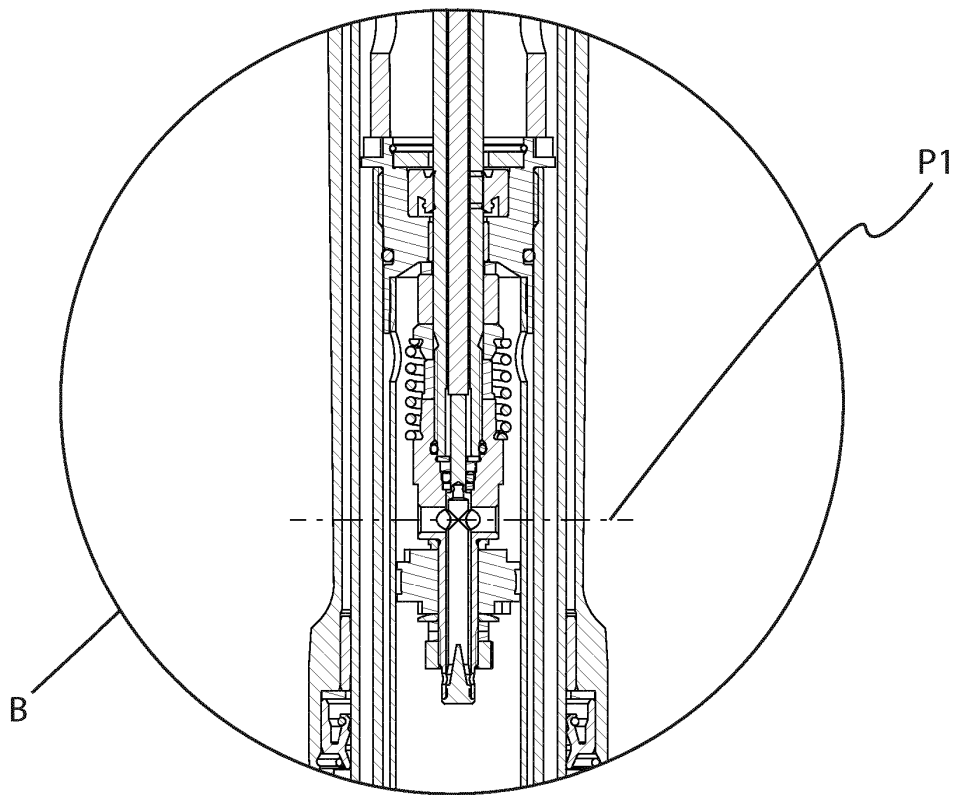

Fig. 4

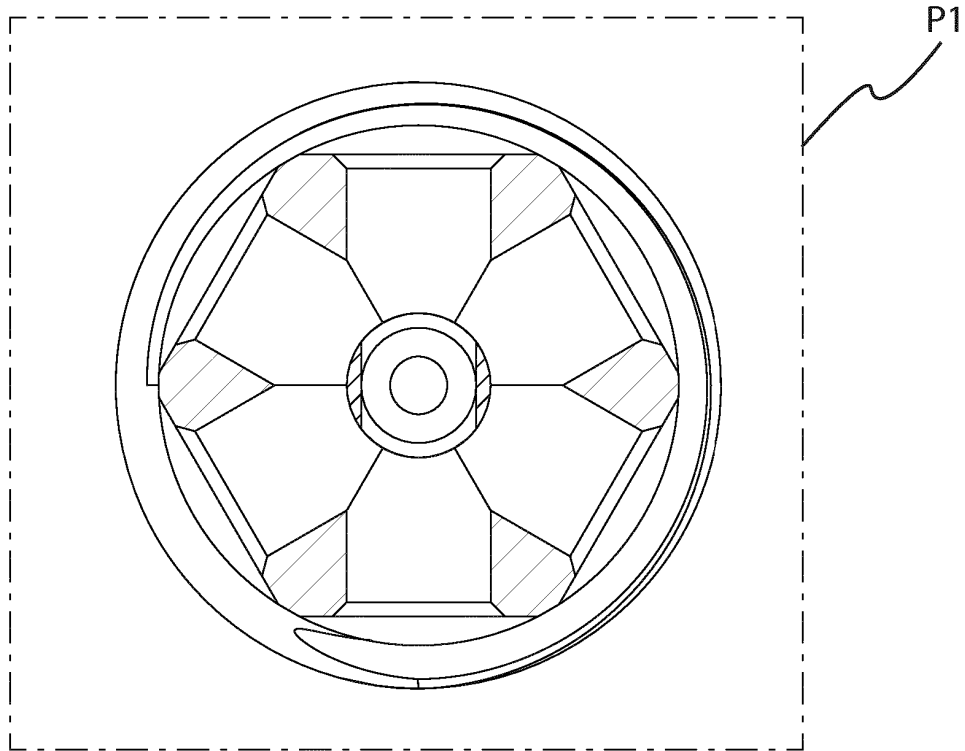

Fig. 5

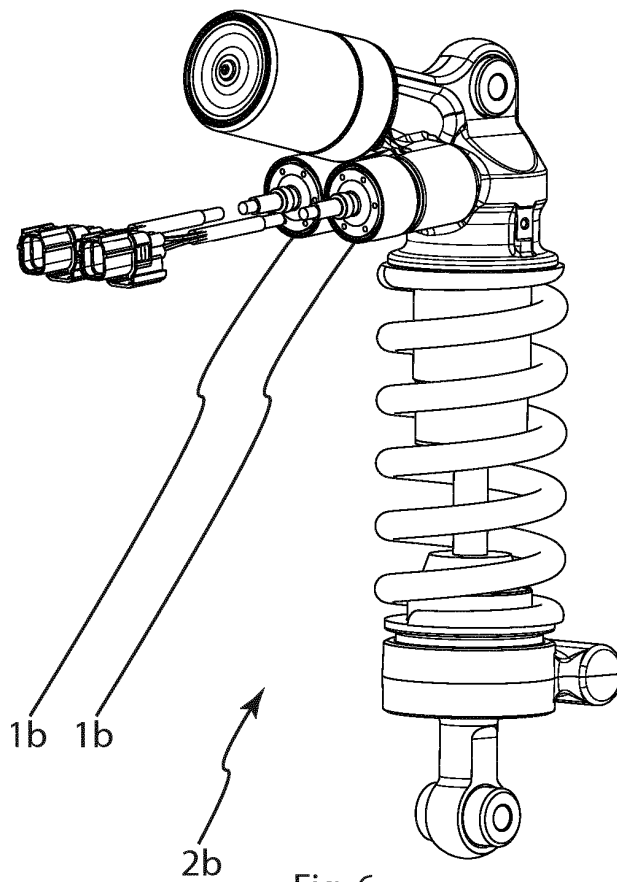

Fig. 6

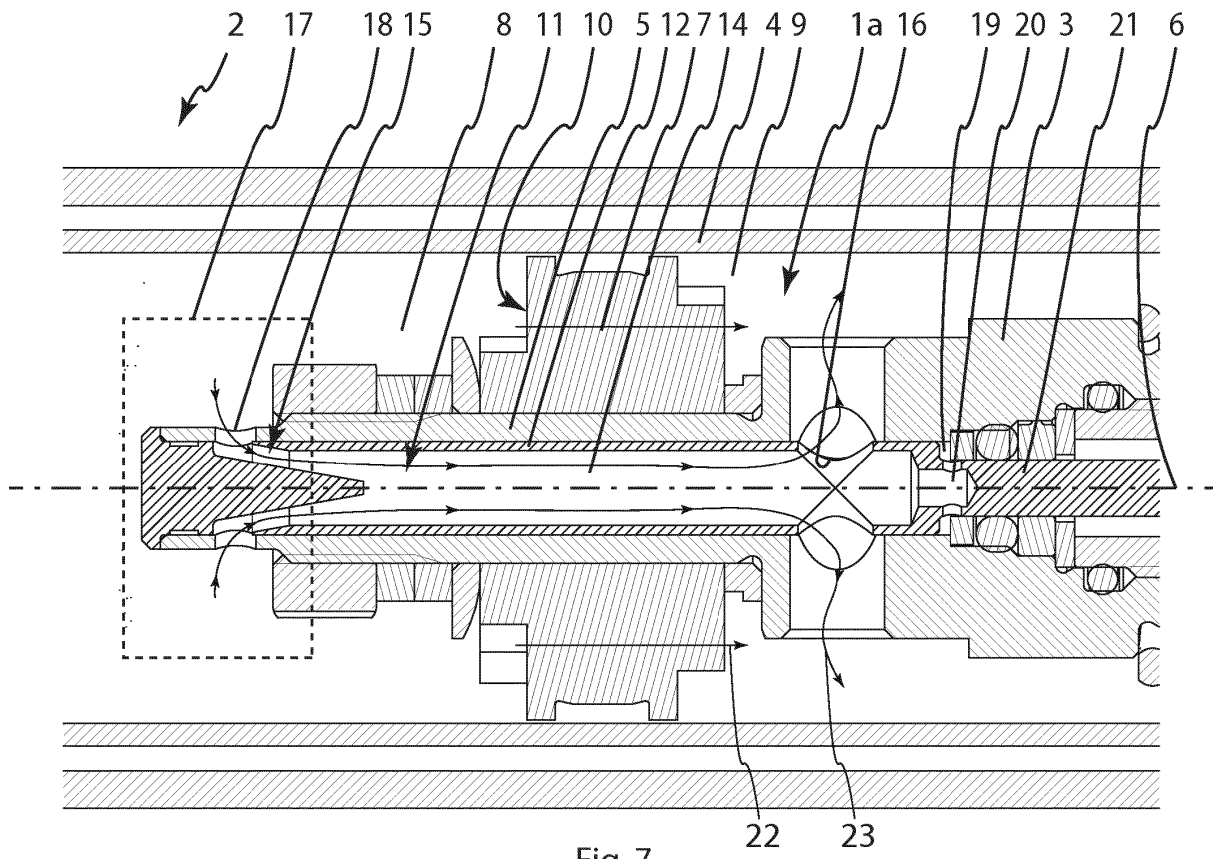

Fig. 7

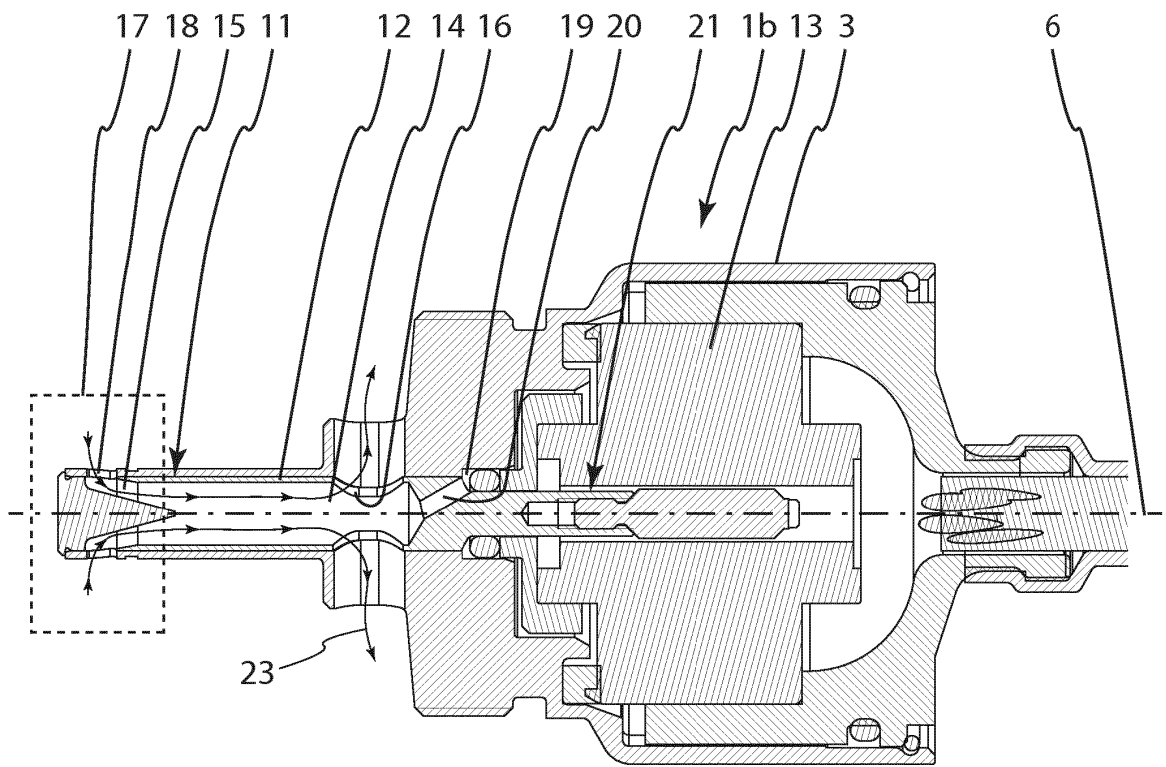

Fig. 8

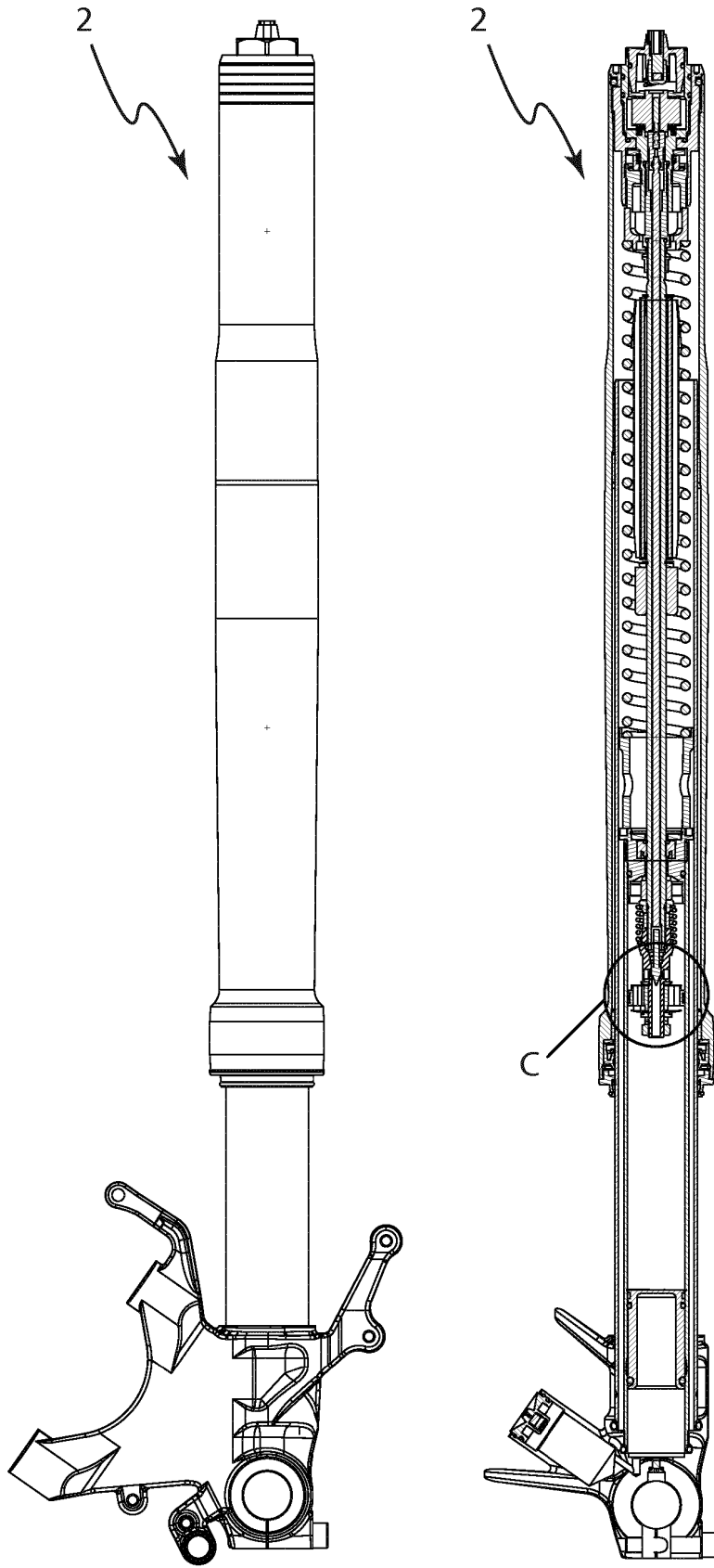

Fig. 9

Fig. 10

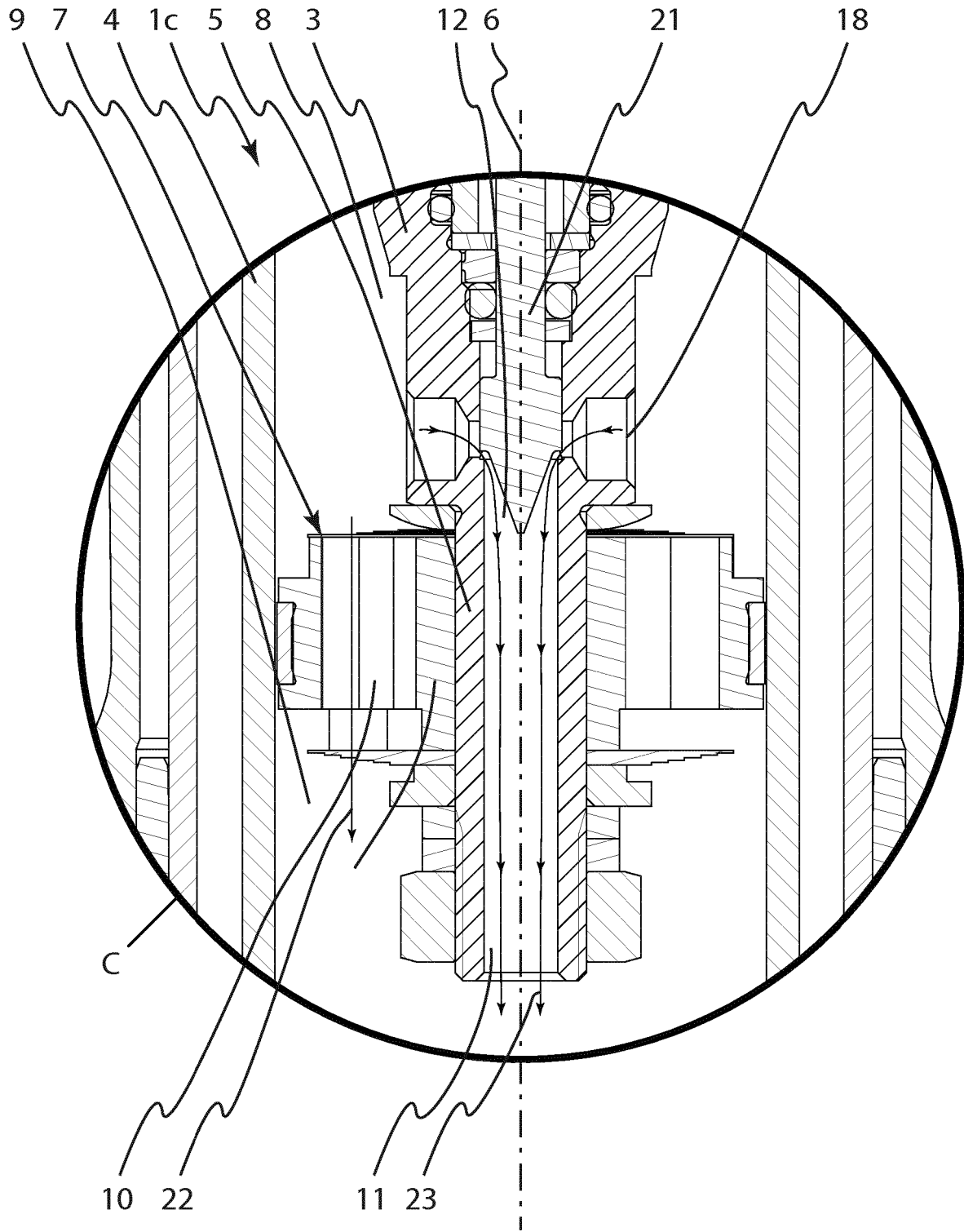

Fig. 11

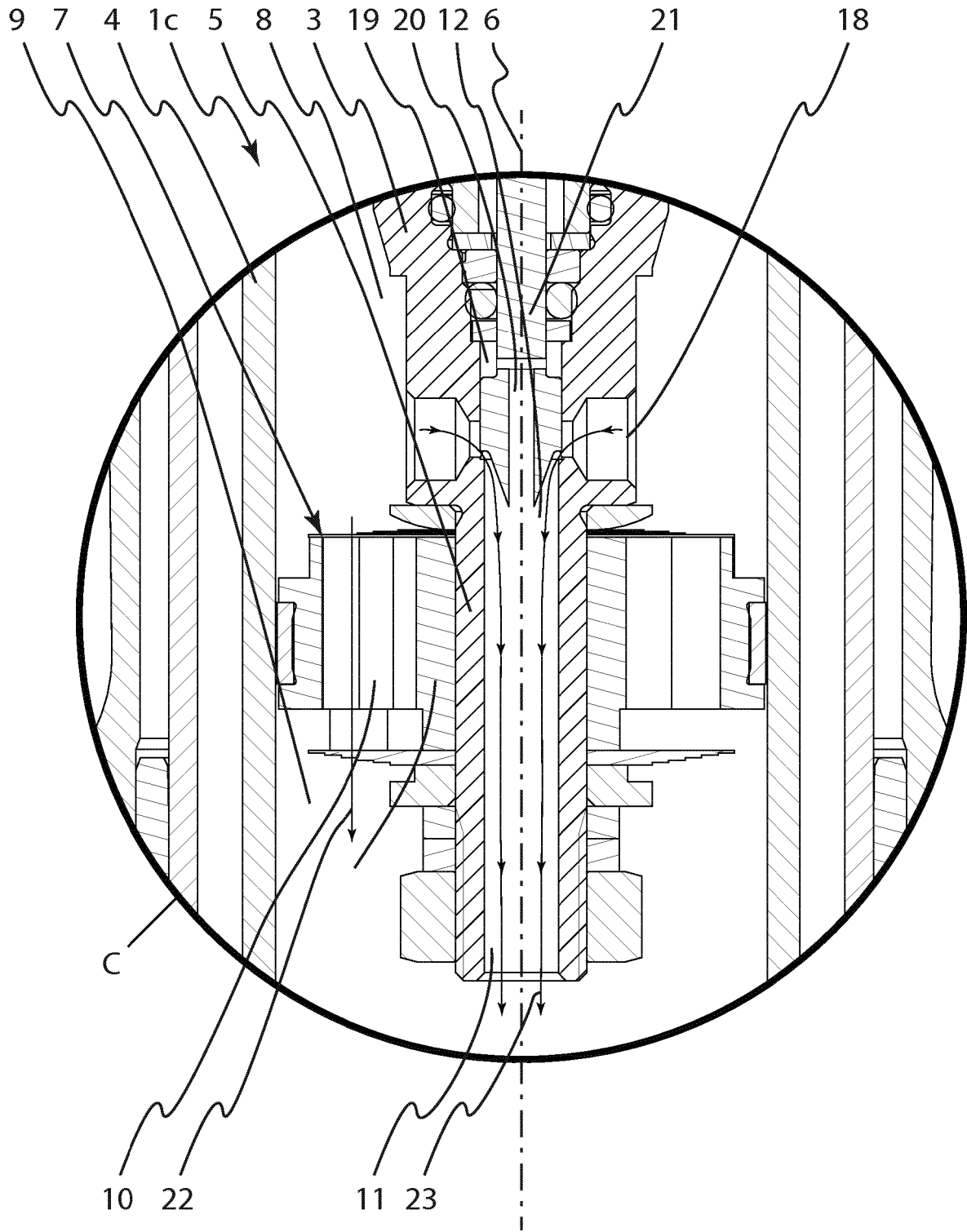

Fig. 12

REFERENCES CITED IN THE DESCRIPTION

This list of references cited by the applicant is for the reader's convenience only. It does not form part of the European patent document. Even though great care has been taken in compiling the references, errors or omissions cannot be excluded and the EPO disclaims all liability in this regard.

Patent documents cited in the description

- WO 2010002314 A1 [0004]
- US 2017082169 A1 [0004]