



(19) **United States**

(12) **Patent Application Publication**
Raimondi et al.

(10) **Pub. No.: US 2017/0230020 A1**

(43) **Pub. Date: Aug. 10, 2017**

(54) **CLASS D SWITCHING AMPLIFIER AND METHOD OF CONTROLLING A LOUDSPEAKER**

(71) Applicant: **STMicroelectronics S.r.l.**, Agrate Brianza (IT)

(72) Inventors: **Marco Raimondi**, Busto Garolfo (IT); **Edoardo Botti**, Vigevano (IT)

(21) Appl. No.: **15/497,313**

(22) Filed: **Apr. 26, 2017**

Related U.S. Application Data

(63) Continuation of application No. 14/797,934, filed on Jul. 13, 2015, now Pat. No. 9,660,586.

Foreign Application Priority Data

Aug. 8, 2014 (IT) TO2014A000650

Publication Classification

(51) **Int. Cl.**
H03F 3/45 (2006.01)
H03F 3/217 (2006.01)
H03F 3/185 (2006.01)
(52) **U.S. Cl.**
CPC **H03F 3/45932** (2013.01); **H03F 3/185** (2013.01); **H03F 3/2173** (2013.01); **H03F 2200/351** (2013.01); **H03F 2200/171** (2013.01); **H03F 2200/78** (2013.01); **H03F 2200/258** (2013.01); **H03F 2200/03** (2013.01)

(57) **ABSTRACT**

A switching amplifier includes a first half-bridge PWM modulator, a second half-bridge PWM modulator, and at least one amplifier stage configured to receive input signals. The switching amplifier also includes a PWM control stage configured to control switching of the first PWM modulator and of the second PWM modulator as a function of the input signals, by respective first PWM control signals and second PWM control signals. The amplifier stage and the PWM control stage have a fully differential structure.

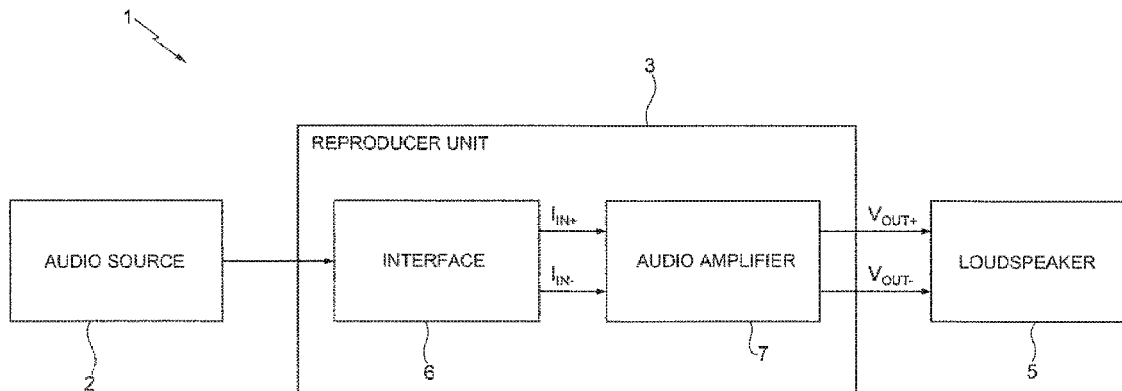

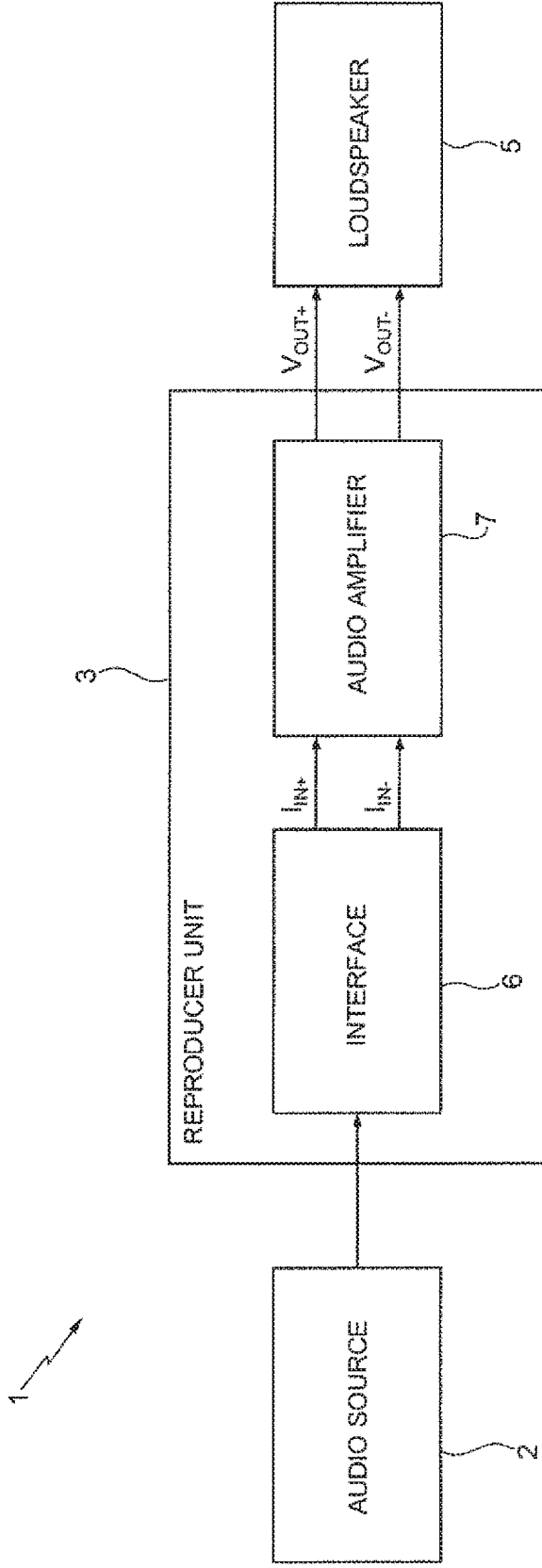

FIG. 1

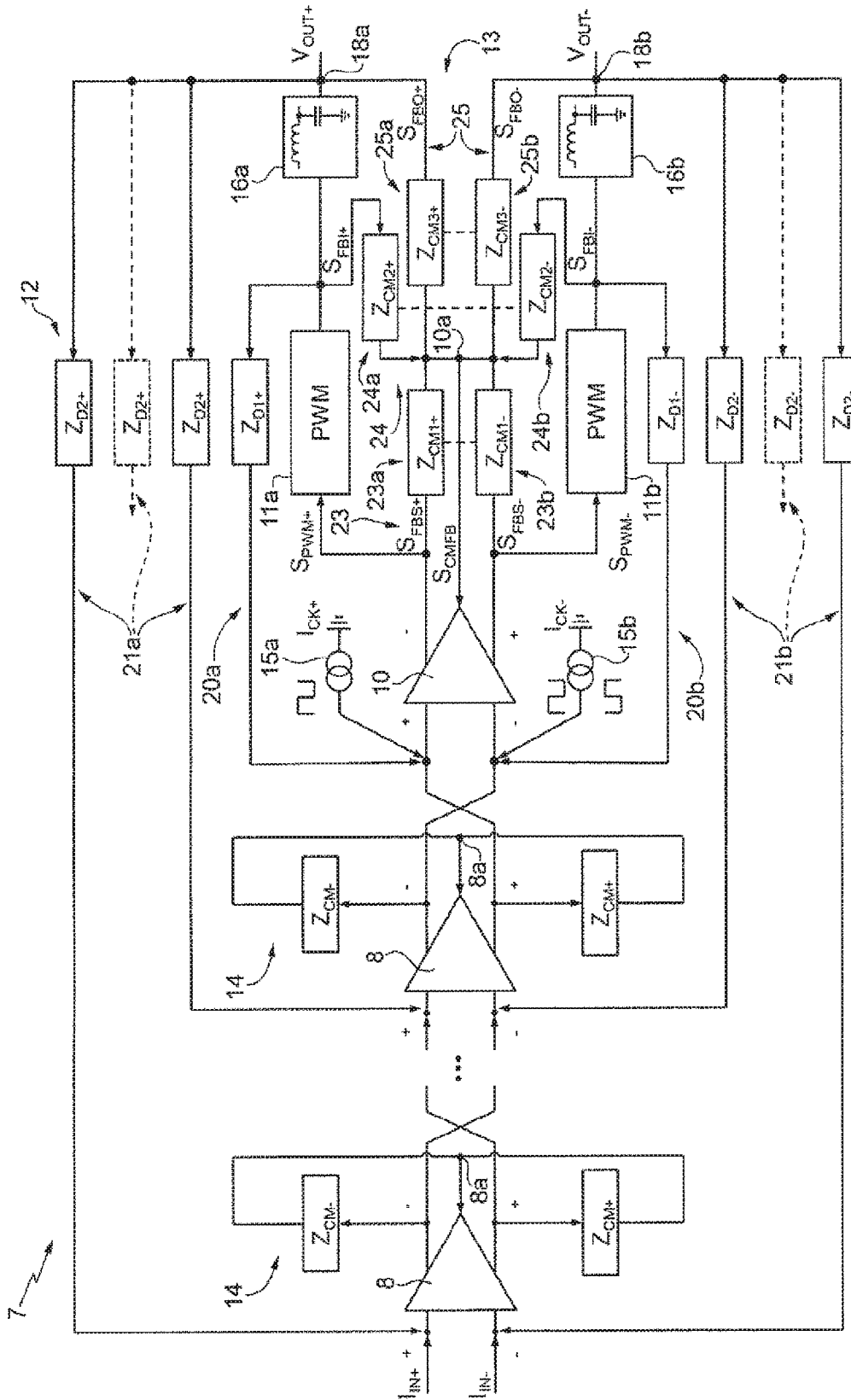

FIG. 2

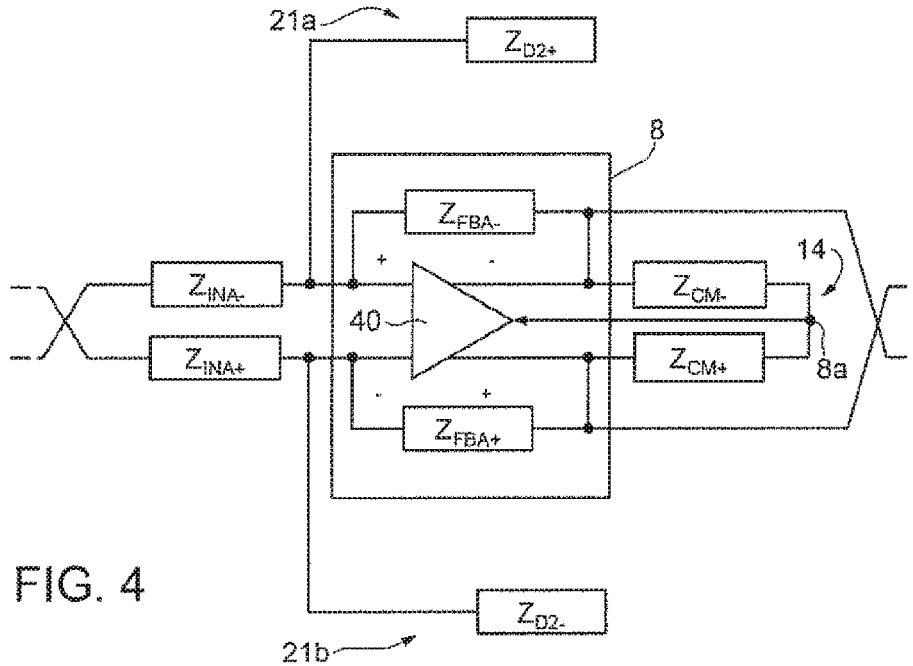

FIG. 4

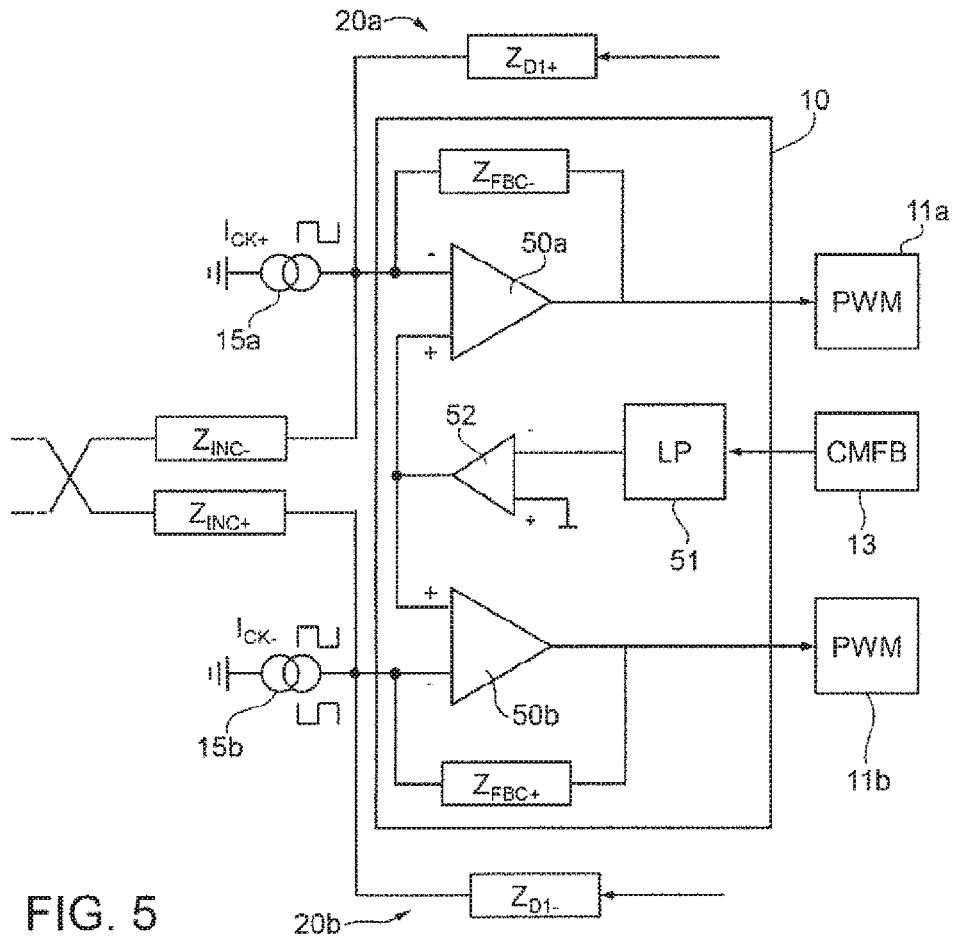

FIG. 5

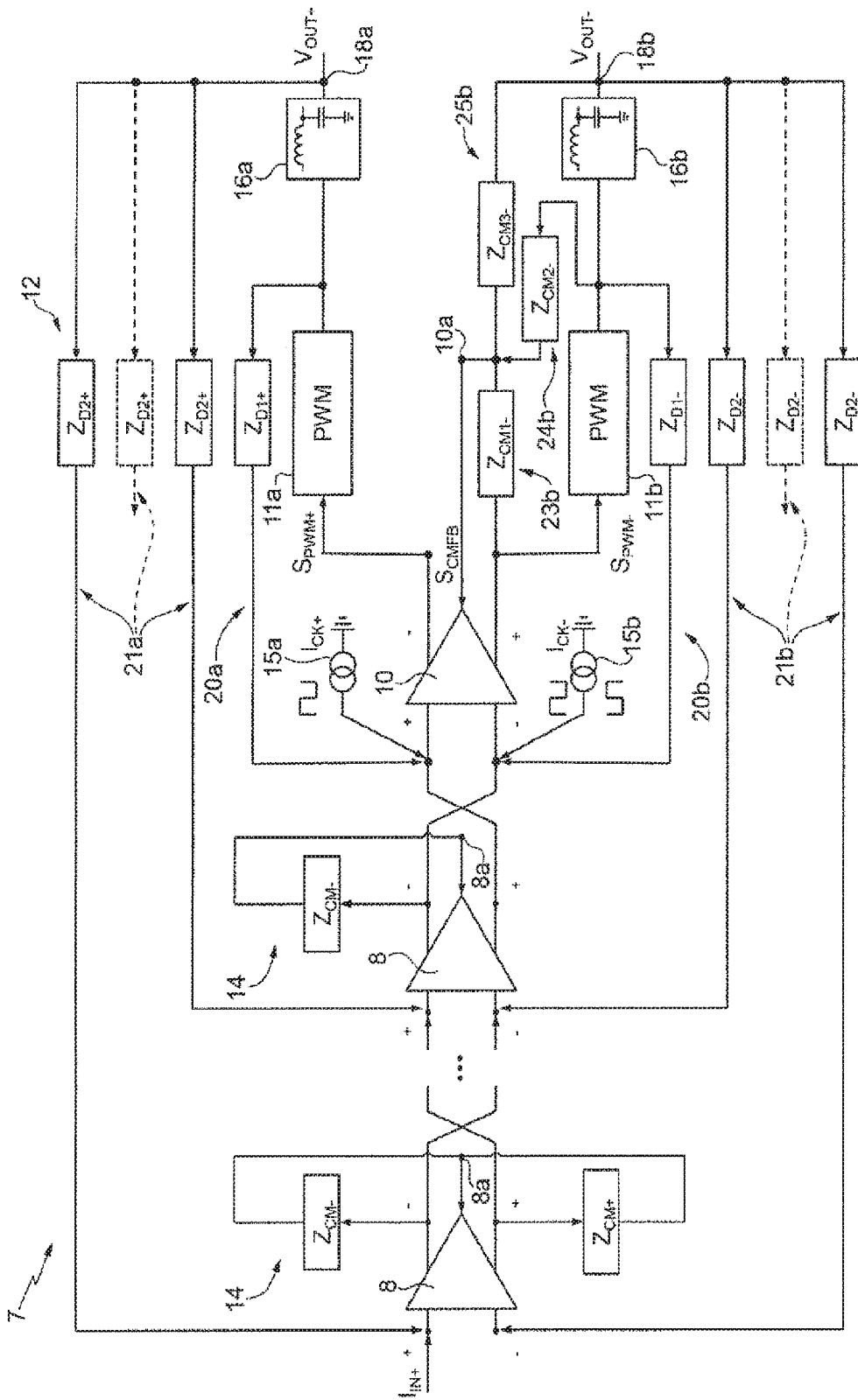

FIG. 6

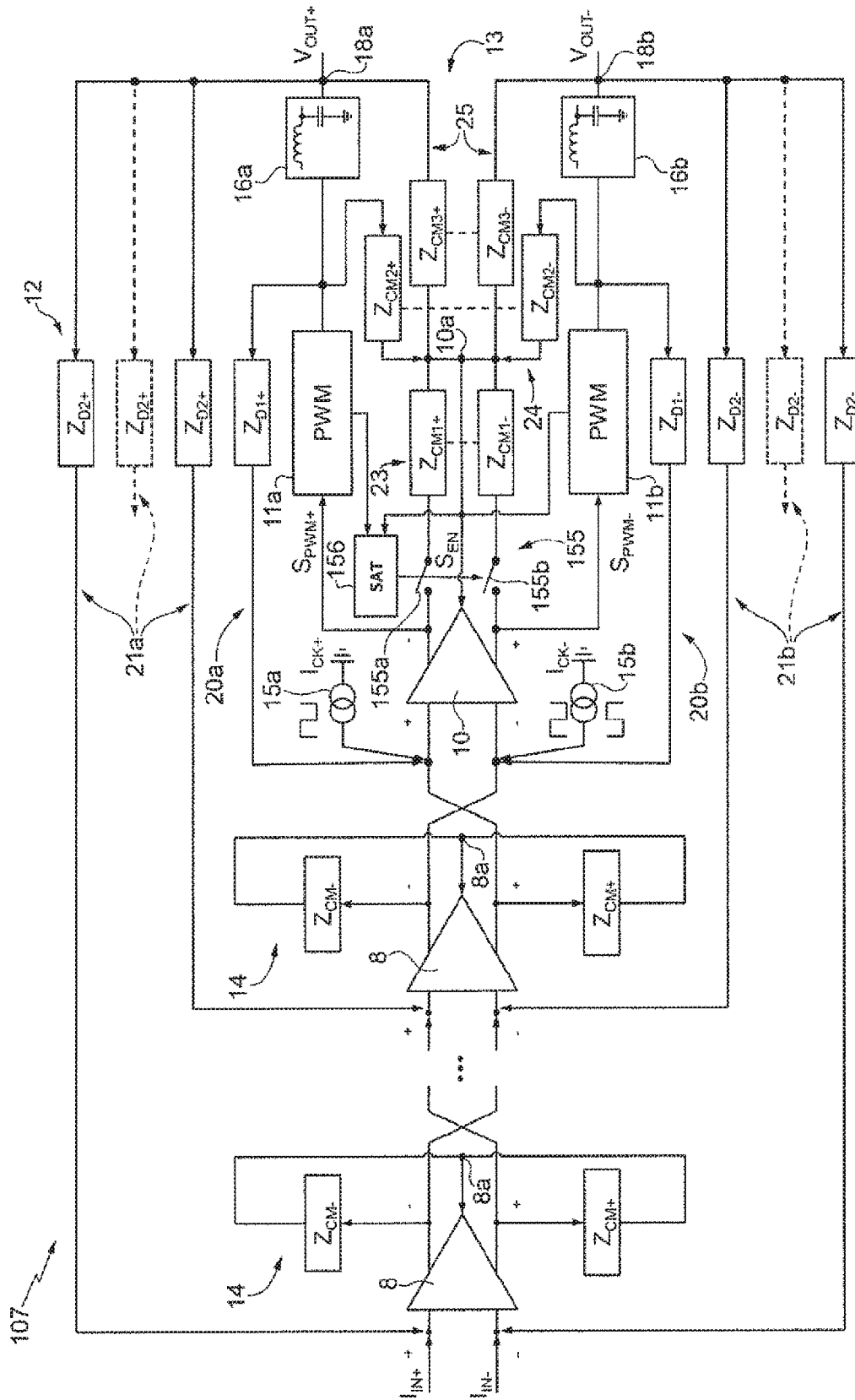

FIG. 7

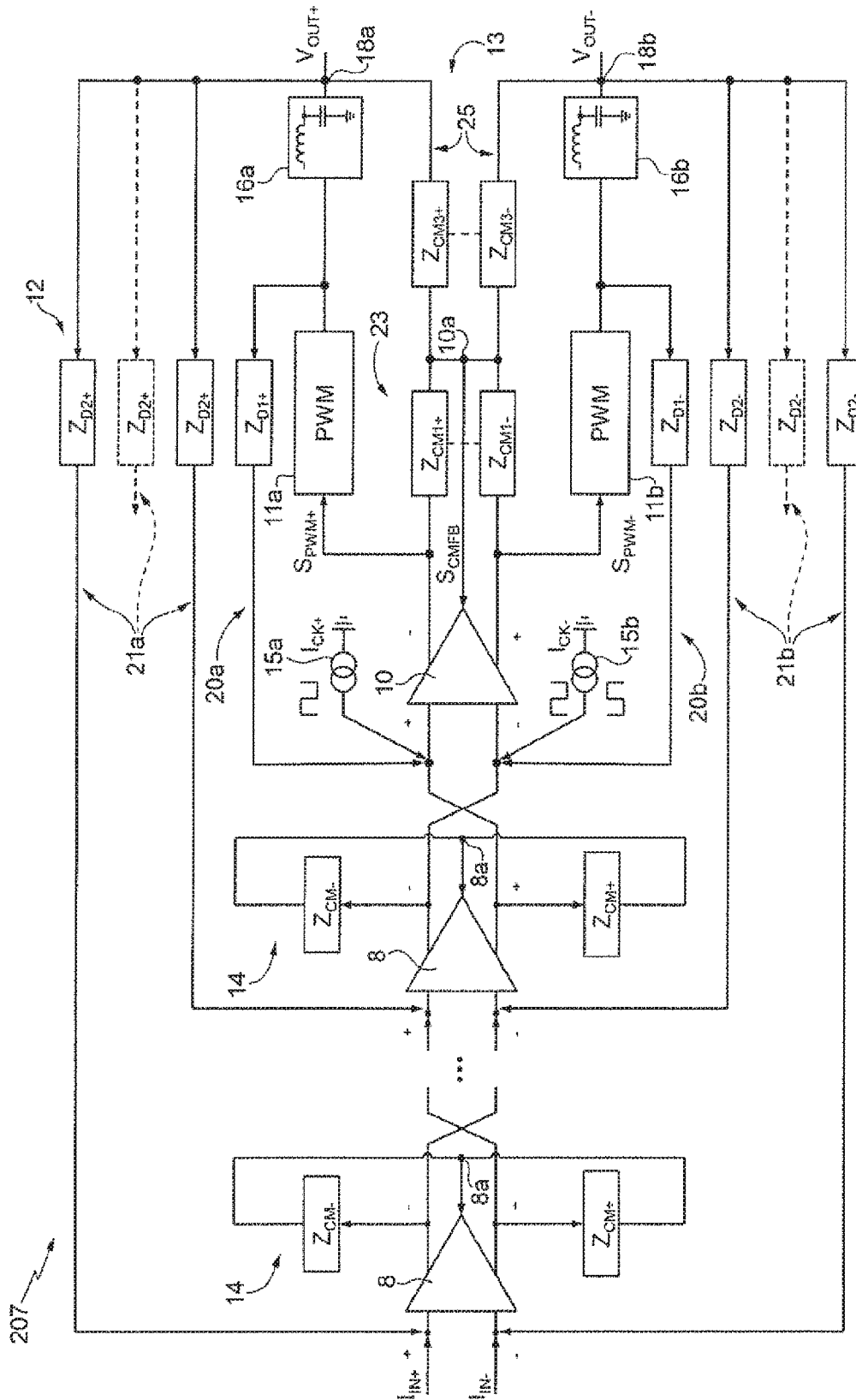

FIG. 8

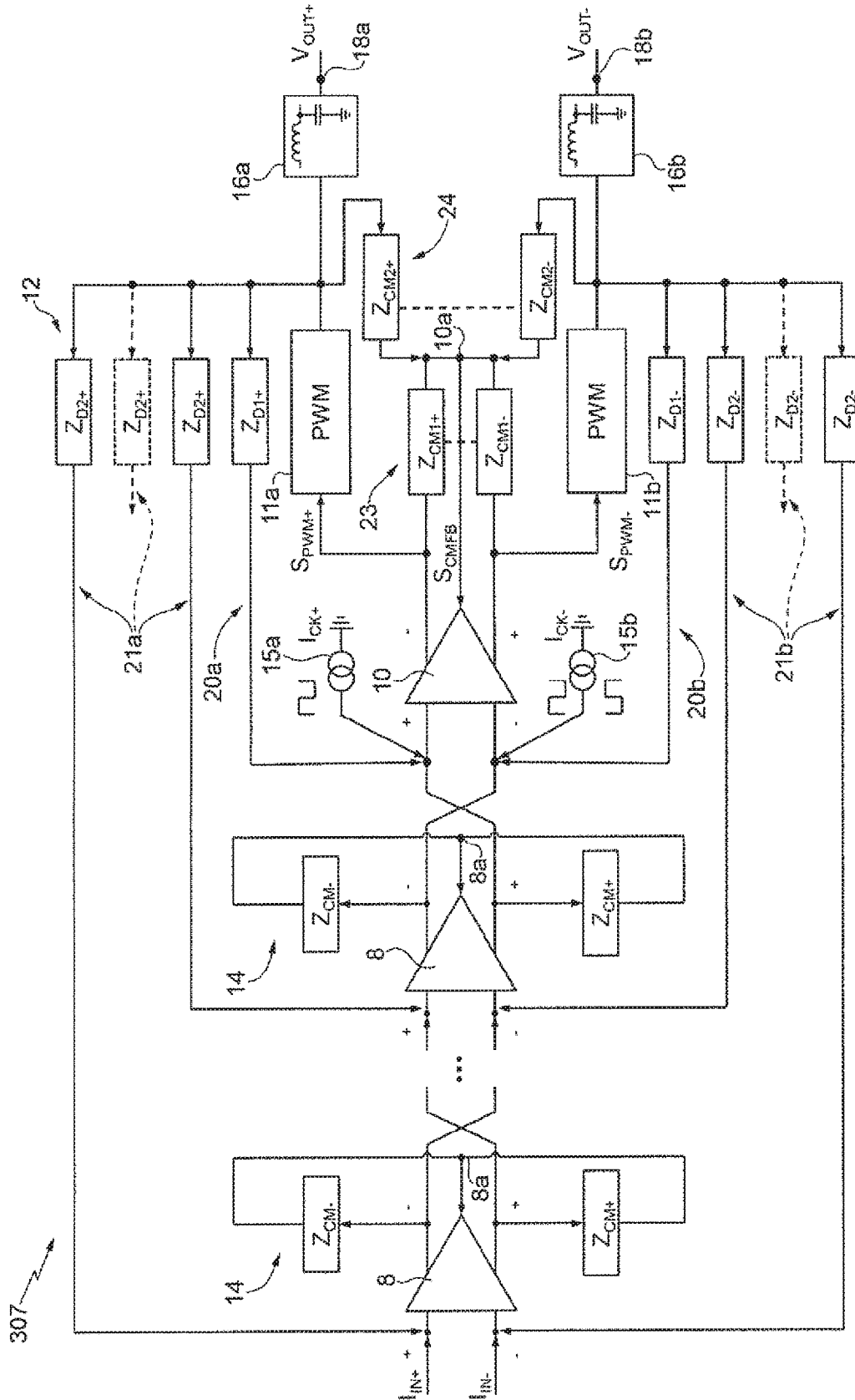

FIG. 9

CLASS D SWITCHING AMPLIFIER AND METHOD OF CONTROLLING A LOUDSPEAKER

CROSS-REFERENCE TO RELATED APPLICATIONS

[0001] This application is a continuation of U.S. patent application Ser. No. 14/797,934, filed on Jul. 13, 2015, which application claims the benefit of Italian Application No. TO2014A000650, filed on Aug. 8, 2014, which application is hereby incorporated herein by reference.

TECHNICAL FIELD

[0002] The present disclosure relates to a class D switching amplifier and to a method of controlling a loudspeaker for use in audio applications.

BACKGROUND

[0003] As is known, some widespread types of amplifiers, for example class D audio amplifiers, exploit full-bridge converter stages in order to maximize the dynamics of the output voltages that may be supplied to the load, maintaining high efficiency.

[0004] A full-bridge converter stage of an audio amplifier is based upon two half-bridge circuits, which may be controlled separately, albeit in a coordinated way, by respective distinct driving stages. This type of technology affords in fact a satisfactory flexibility of use. For instance, it is possible to implement pulse width modulation (PWM) techniques, both in phase and in phase opposition.

[0005] The driving stages have the same structure and receive at input signals in phase opposition that are used for controlling the respective half-bridge circuits symmetrically.

[0006] A limit of known amplifiers that are based upon independent driving stages is represented by the rejection of common-mode disturbance.

[0007] Possible defects of symmetry of the two driving stages may easily lead to unbalancing that affects the rejection of supply disturbance and cause so-called “crosstalk” phenomena.

[0008] Furthermore, known structures suffer from a certain sensitivity to high-frequency noise, which is typical of analog-to-digital converters of a sigma-delta type, which are frequently used upstream of the stages for driving the final power stages.

[0009] Known technology for overcoming the sensitivity to high-frequency disturbance lead on the other hand to an increase in the number of components and, consequently, in the complexity of the amplifiers.

SUMMARY

[0010] A switching amplifier includes a first half-bridge PWM modulator, a second half-bridge PWM modulator, and at least one amplifier stage configured to receive input signals. The switching amplifier also includes a PWM control stage configured to control switching of the first PWM modulator and of the second PWM modulator as a function of the input signals, by respective first PWM control signals and second PWM control signals. The amplifier stage and the PWM control stage have a fully differential structure.

BRIEF DESCRIPTION OF THE DRAWINGS

[0011] For a better understanding of the invention, some embodiments thereof will now be described purely by way of non-limiting example with reference to the attached drawings, wherein:

[0012] FIG. 1 is a simplified block diagram of an audio system according to the invention;

[0013] FIG. 2 is a more detailed block diagram of a switching amplifier according to one embodiment of the present invention, incorporated in the audio system of FIG. 1;

[0014] FIG. 3 is a more detailed block diagram of a first component of the switching amplifier of FIG. 2;

[0015] FIG. 4 is a more detailed block diagram of a second component of the switching amplifier of FIG. 2;

[0016] FIG. 5 is a more detailed block diagram of a third component of the switching amplifier of FIG. 2;

[0017] FIG. 6 shows the switching amplifier of FIG. 2 in a different operating configuration;

[0018] FIG. 7 is a block diagram of the switching amplifier according to a different embodiment of the present invention;

[0019] FIG. 8 is a block diagram of the switching amplifier according to a further embodiment of the present invention; and

[0020] FIG. 9 is a block diagram of the switching amplifier according to another embodiment of the present invention.

DETAILED DESCRIPTION OF ILLUSTRATIVE EMBODIMENTS

[0021] With reference to FIG. 1, an audio system designated as a whole by the number 1 comprises a signal source 2, a reproducer unit 3 and at least one loudspeaker 5.

[0022] The signal source 2 is configured to supply audio signals SA. It may, for example, but not exclusively, be a tuner, a stereo or “home theater” system, a cellphone or a reproducer of audio files, such as a module for reproducing audio files incorporated in a smartphone, a tablet, a portable computer, or a personal computer.

[0023] The reproducer unit 3 comprises an interface 6, coupled to the signal source 2 and configured to convert the audio signals SA into corresponding input signals I_{IN+} , I_{IN-} and an audio amplifier 7, configured to drive the loudspeaker 5 by output signals V_{OUT+} , V_{OUT-} as a function of the input signals I_{IN+} , I_{IN-} .

[0024] In one embodiment, the input signals I_{IN+} , I_{IN-} and the output signals V_{OUT+} , V_{OUT-} are differential signals, for example, respectively, differential currents and differential voltages.

[0025] The loudspeaker 5 may, for example, be an element of a set of loudspeakers or an ear-piece of an earphone set.

[0026] In one embodiment, the audio amplifier 7 has the structure illustrated in a simplified way in FIG. 2. The audio amplifier 7 is a class D switching amplifier, uses two PWM modulators each based upon a MOSFET half-bridge and has a structure with nested feedback control loops. In greater detail, the audio amplifier 7 comprises a cascaded chain of amplifier stages 8, a PWM control stage 10, a first PWM modulator 11a, a second PWM modulator 11b, a differential feedback-control network 12 and a common-mode feedback-control network 13.

[0027] The amplifier stages 8, which in FIG. 2 are represented in a simplified way, are of a fully differential type. By

convention, it will be understood hereinafter that each fully differential stage or structure has a positive input, a negative input, a positive output, a negative output and a common-mode control network. In particular, the terms “positive” and “negative” are herein to be understood in the sense that a variation to the positive input produces a variation of the same sign on the positive output and a variation of an opposite sign on the negative output. A variation to the negative input produces a variation of the same sign on the negative output and a variation of an opposite sign on the positive output. It is evident that the terms “positive” and “negative” may be exchanged. Furthermore, each fully differential stage or structure has a common-mode control terminal.

[0028] The first amplifier stage **8** of the series is coupled to the interface **6** (not illustrated in FIG. 2) for receiving the input signals I_{IN+} , I_{IN-} . Furthermore, each differential stage **8** has the positive output and the negative output coupled to the positive input and to the negative input of the next amplifier stage **8**, respectively.

[0029] The last amplifier stage **8** of the series has the positive output and the negative output coupled, respectively, to the positive input and to the negative input of the PWM control stage **10**, which has a fully differential structure and is also represented in a simplified way in

[0030] FIG. 2.

[0031] The amplifier stages **8** are further provided with common-mode control networks **14**, between the respective outputs and a respective common-mode control terminal **8a**. The common-mode control networks **14** have respective impedances Z_{CM+} , Z_{CM-} that may be the same as one another or different, according to the requirements.

[0032] As well as being coupled to the outputs of the last amplifier stage **8** of the series, the positive input and the negative input of the PWM control stage **10** are coupled, respectively, to a first reference generator **15a**, for receiving a first reference signal I_{CK+} and to a second reference generator **15b**, for receiving a second reference signal I_{CK-} . In one embodiment, the reference signals I_{CK+} , I_{CK-} are square-wave currents that have a switching frequency and are integrated by the PWM control stage **10**. In a different embodiment (not illustrated), the reference signals may be sawtooth voltages with a frequency equal to the switching frequency supplied directly to the first PWM modulator **11a** and to the second PWM modulator **11b**, respectively. Furthermore, the reference signals I_{CK+} , I_{CK-} (whether square-wave or sawtooth) may be supplied in phase opposition for carrying out a modulation of an out-of-phase type, or else in phase, for carrying out a modulation of an in-phase type.

[0033] The negative output and the positive output of the PWM control stage **10** are coupled, respectively, to the first PWM modulator **11a** and to the second PWM modulator **11b** and supply, respectively, a first PWM control signal S_{PWM+} and a second PWM control signal S_{PWM-} . The first PWM control signal S_{PWM+} and the second PWM control signal S_{PWM-} cause switching, respectively, of the first PWM modulator **11a** and of the second PWM modulator **11b** at the frequency of the reference signals I_{CK+} , I_{CK-} and with a duty cycle that is a function of the input signals I_{IN+} , I_{IN-} .

[0034] A first output filter **16a** is connected between an output of the first PWM modulator **11a** and a first output terminal **18a** and comprises a first LC network. A second output filter **16b** is coupled between an output of the second PWM modulator **11b** and a second output terminal **18b** and

comprises a second LC network. The loudspeaker **5** is coupled between the outputs **18a**, **18b** and defines a load of the audio amplifier **7**.

[0035] The differential feedback-control network **12** has: a feedback branch **20a**, having an impedance Z_{D1+} , which picks up a feedback signal from the output of the first PWM modulator **11a** (upstream of the first output filter **16a**) and is coupled to the positive input of the PWM control stage **10**; a feedback branch **20b**, having an impedance Z_{D1-} , which picks up a feedback signal from the output of the second PWM modulator **11b** (upstream of the second output filter **16b**) and is coupled to the negative input of the PWM control stage **10**; a plurality of feedback branches **21a**, which have respective impedances Z_{D2+} and are coupled to the first output terminal **18a** (downstream of the first output filter **16a**) and each to the positive input of a respective amplifier stage **8**; and a plurality of feedback branches **21b**, which have respective impedances Z_{D2-} and are coupled to the second output terminal **18b**, (downstream of the second output filter **16b**) and each to the negative input of a respective amplifier stage **8**.

[0036] The differential feedback-control network **12** thus provides a nested feedback-loop structure.

[0037] The common-mode feedback-control network **13** includes the first PWM modulator **11a** and the second PWM modulator **11b** and is configured to pick up feedback signals between the outputs of the PWM control stage **10** and the output terminals **18a**, **18b** and to supply a common-mode control signal S_{CMFB} to a common-mode control terminal **10a** of the PWM control stage **10**, for maintaining a common-mode voltage of the PWM control stage **10** substantially constant.

[0038] In one embodiment, the common-mode feedback-control network **13** comprises a clipping control loop **23**, an inner control loop **24** and an outer control loop **25**.

[0039] The clipping control loop **23** has: a branch **23a**, having an impedance Z_{CM1+} , between the negative output of the PWM control stage **10** and its common-mode control terminal **10a**; and a branch **23b**, having an impedance Z_{CM1-} , between the positive output of the PWM control stage **10** and its common-mode control terminal **10a**. The clipping control loop **23** thus picks up clipping feedback signals S_{FBS+} , S_{FBS-} upstream of the PWM modulators **11a**, **11b**.

[0040] The inner control loop **24** has: a branch **24a**, having an impedance Z_{CM2+} , between the output of the first PWM modulator **11a** and the common-mode control terminal **10a** of the PWM control stage **10**; and a branch **24b**, having an impedance Z_{CM2-} , between the output of the second PWM modulator **11b** and the common-mode control terminal **10a**.

The inner control loop **24** is thus internal to the output filters **16a**, **16b** and picks up inner clipping feedback signals S_{FBI+} , S_{FBI-} downstream of the PWM modulators **11a**, **11b**.

[0041] The outer control loop **25** has: a branch **25a**, having an impedance Z_{CM3+} , between the first output terminal **18a** and the common-mode control terminal **10a**; and a branch **25b**, having an impedance Z_{CM3-} , between the second output terminal **18b** and the common-mode control terminal **10a**. The outer control loop **25** is thus external to the output filters **16a**, **16b** and picks up outer clipping feedback signals S_{FBO+} , S_{FBO-} downstream both of the PWM modulators **11a**, **11b** and of the output filters **16a**, **16b**.

[0042] In the embodiment described and illustrated in FIG. 2, the clipping feedback signals S_{FBS+} , S_{FBS-} coincide

with the PWM control signals S_{PWM+} , S_{PWM-} , the inner clipping feedback signals S_{FBI+} , S_{FBI-} coincide with the signals supplied by the PWM modulators **11a**, **11b** and the outer clipping feedback signals S_{FBO+} , S_{FBO-} coincide with the output signals V_{OUT+} , V_{OUT-} .

[0043] In FIG. 2, possible connections between the branch **23a** and the branch **23b**, between the branch **24a** and the branch **24b** and between the branch **25a** and the branch **25b** are represented schematically by dashed lines.

[0044] Consequently, the clipping control loop **23** picks up its own feedback signals between the PWM control stage **10** and the PWM modulators **11a**, **11b**. The inner control loop **24** and the outer control loop **25** pick up the respective feedback signals, respectively, upstream and downstream of the output filters **16a**, **16b**.

[0045] The first PWM modulator **11a** and the second PWM modulator **11b** are of the half-bridge type and are driven separately, respectively, by the negative output and the positive output of the PWM control stage **10**. As illustrated in FIG. 3, the first PWM modulator **11a** and the second PWM modulator **11b** each comprise: a comparator stage **30a** (**30b**), for example a threshold comparator, possibly with hysteresis; and two switches **27a**, **28a** (**27b**, **28b**), which are defined by respective MOS transistors and are arranged in series between a supply line **29** and ground and are controlled by the comparator stage **30a** (**30b**) through respective driving circuits **31a**, **32a** (**31b**, **32b**). The comparator stages **30a**, **30b** have first inputs coupled, respectively, to the negative output and to the positive output of the PWM control stage **10** and second inputs coupled to a reference generator **35**, which supplies a constant reference signal. In one embodiment (not illustrated), the reference generator may supply a sawtooth or triangular reference signal. In this case, the reference generators **15a**, **15b** may be omitted.

[0046] As already noted (FIG. 2), the first PWM modulator **11a** and the second PWM modulator **11b** are included in the control loops of the common mode of the PWM control stage **10** provided by the common-mode feedback-control network **13**.

[0047] The fully differential structure of the amplifier stages **8** and of the PWM control stage **10** enables substantial limitation of the possible defects of symmetry, avoiding any unbalancing that might affect rejection of disturbance. Furthermore, thanks to the fully differential structure, maintenance of the sign at each step of the chain of amplifier stages **8** is obtained simply by coupling the positive and negative outputs of one stage to the positive and negative inputs, respectively, of the next stage. There is thus the advantage of a reduced sensitivity to high-frequency disturbance, typical of inverting configurations, without any need to use purposely provided inversion stages for obtaining the correct sign, with benefit in terms of number of components, complexity of construction, area occupied and, ultimately, costs.

[0048] The common-mode feedback-control network **13** generally allows to set the common mode of the PWM control stage **10** effectively, enabling, among other things, both to use an in-phase modulation scheme, if desired, and to implement diagnostic techniques that envisage operation in single-ended mode (this aspect will be taken up in greater detail in what follows).

[0049] Furthermore, the innermost clipping control loop **23** enables stable maintenance of the common mode also

when the input signals I_{IN+} , I_{IN-} cause clipping of the PWM modulators **11a**, **11b** (in practice, the duty cycle is constantly forced to 100% or 0%, exhausting the available margin). In this eventuality, the control loops that pick up the feedback signals downstream of the PWM modulators **11a**, **11b** are ineffective because the respective feedback signals remain unchanged despite variations of the input signals I_{IN+} , I_{IN-} and, within given intervals, also of the outputs of the PWM control stage **10**. In the absence of common-mode control, the common-mode offsets may cause drift of the control signals and exit from the clipping condition of one of the PWM modulators **11a**, **11b** (according to the sign of the offsets), reducing the maximum output power available. In general, operation of the audio amplifier would present anomalies.

[0050] The clipping control loop **23**, instead, continues to operate properly up to saturation of the PWM control stage **10** and thus with an available swing that is wider than in clipping conditions. The common-mode control of the PWM control stage **10** is thus effective and all the power available may be properly supplied.

[0051] The outer control loop **25** picks up its feedback signals downstream of the output filters **16a**, **16b**, which are thus included in the common-mode control structure. The outer control loop **25** thus enables damping of the common-mode resonance of the output filters **16a**, **16b**, whereas the differential-mode resonance is attenuated by the differential feedback-control network **12**, as well as by the load present between the output terminals **18a**, **18b** (in this case, the loudspeaker **5**).

[0052] In one embodiment, the amplifier stages **8** have the structure illustrated in FIG. 4. FIG. 4 shows, by way of example, a single amplifier stage **8**. It is, however, understood that what is described hereinafter applies to all the amplifier stages **8** present. In particular, each amplifier stage **8** comprises a fully differential amplifier **40** provided with feedback impedances Z_{FBA+} , Z_{FBA-} . Input impedances T_{INA+} , T_{INA-} (not illustrated for simplicity in FIG. 2) are further coupled to the positive and negative inputs of the fully differential amplifier **40**. The positive and negative inputs of the fully differential amplifier **40** define, respectively, the positive and negative inputs of the amplifier stage **8**. The input impedances T_{INA+} , T_{INA-} , which are arranged in series to respective inputs of the fully differential amplifier **40**, for simplicity are not represented in the simplified diagram of FIG. 2. It is understood in any case that the positive and negative outputs of each amplifier stage **8** are coupled, respectively, to the positive and negative inputs of the next amplifier stage **8** of the chain through the input impedances T_{INA-} , T_{INA+} of the latter. The feedback branches **21a**, **21b** of the differential feedback-control network **12** are coupled to the positive and negative inputs, respectively, of the fully differential amplifier **40**. The feedback impedances Z_{FBA+} , Z_{FBA-} are arranged the first between the negative input and the positive output and the second between the positive input and the negative output. The outputs and the common-mode control terminal **8a** of the amplifier stage **8** are defined, respectively, by the outputs and by a common-mode control terminal of the fully differential amplifier **40**.

[0053] FIG. 5 illustrates the structure of the PWM control stage **10** in one embodiment. The PWM control stage **10** comprises a first control amplifier **50a**, a second control

amplifier **50b**, input impedances $T_{I_{NC+}}$, $T_{I_{NC-}}$, feedback impedances Z_{FBC+} , Z_{FBC-} , a low-pass filter **51** and an error amplifier **52**.

[0054] The first control amplifier **50a** and the second control amplifier **50b** are of the single-terminal type and are coupled symmetrically between the positive and negative inputs and the positive and negative outputs for forming a fully differential structure. More precisely, the input impedances $T_{I_{NC-}}$, $T_{I_{NC+}}$ are coupled in series to first inputs of the same type (for example, inverting inputs), respectively, of the first control amplifier **50a** and of the second control amplifier **50b**, which have the feedback impedances Z_{FBC+} , Z_{FBC-} coupled between the same inputs and the respective outputs. The outputs of the first control amplifier **50a** and of the second control amplifier **50b** define, respectively, the negative output and the positive output of the PWM control stage **10**. The square-wave reference signals I_{CK+} , I_{CK-} are injected, respectively, at input to the first control amplifier **50a** and the second control amplifier **50b**.

[0055] The low-pass filter **51** has an input that defines the common-mode control terminal **10a** of the PWM control stage **10** and an output coupled to an input of the error amplifier **52**. The error amplifier **52** has a further input, which receives a common-mode reference signal and an output coupled to second inputs of the same type (for example, non-inverting inputs) of the first control amplifier **50a** and of the second control amplifier **50b**, respectively.

[0056] The low-pass filter **51** has a cutoff frequency lower than the switching frequency of the reference signals I_{CK+} , I_{CK-} , for example by at least one decade, and limits the band of the feedback loops defined by the common-mode feedback-control network **13**. By virtue of the feedback impedances Z_{FBC+} , Z_{FBC-} , the inverting inputs of the control amplifiers **50a**, **50b** are kept at the same voltage as the corresponding non-inverting inputs when the reference signals I_{CK+} , I_{CK-} are injected. The low-pass filter **51**, by limiting the band, prevents the feedback loops defined by the common-mode feedback-control network **13** from reacting to the variations due to oscillations of the reference signals I_{CK+} , I_{CK-} . In practice, the low-pass filter **51** allows to attenuate and substantially suppress the oscillations at the switching frequency fed back from the common-mode feedback-control network **13** to the common-mode control terminal **10a**. The output of the error amplifier **52** and the inputs of the control amplifiers **50a**, **50b** coupled thereto are not affected by these oscillations and the waveforms on the outputs of the control amplifiers **50a**, **50b** towards the PWM modulators **11a**, **11b** are preserved. This enables operation of the audio amplifier **7** both in in-phase mode and in single-terminal mode (for example, to implement functions of diagnostics of the load) albeit using amplification stages and a PWM control stage with a fully differential structure, which would otherwise not be recommended. The audio amplifier described may consequently be used in a flexible way, in addition to enjoying the benefit of the fully differential structure as regards having low sensitivity to disturbance.

[0057] As mentioned, the audio amplifier **7** described may be used in single-terminal mode to implement diagnostic functions for the load. For this purpose, a test signal, for example a voltage, is applied to a load present between the output terminals **18a**, **18b** and the current consequently produced is read, checking whether it remains within a range of values indicating that operation is correct and the load is

connected. In class D amplifiers, however, reading of the load current is affected by an error due to the current that flows through the capacitive portion of the LC output filters, in particular if the testing frequency is high. To reduce the reading error, during testing one of the outputs is kept in conditions of rest, i.e., with a substantially zero signal present. The current that flows in the PWM modulator (half-bridge) driven in this way is substantially equal to the current in the load, as described in EP-A-2 048 896, in the name of the present applicant.

[0058] The operating conditions referred to above may be obtained in the audio amplifier **7** in the way referred to hereinafter, with reference to FIG. 6. The input signal on one of the inputs of the audio amplifier **7** (for example, the input signal I_{IN-}) is annulled and the common-mode control on the amplifier stage **8** immediately upstream of the PWM control stage **10** is performed through just one of the outputs, for example the negative output. In practice, a portion of the corresponding common-mode control network **14** (for example, the branch Z_{CM+} corresponding to the positive output) is disabled or excluded. Furthermore, the portion of the common-mode feedback-control network **13** corresponding to one of the outputs of the PWM control stage **10** (for example, the branches **23a**, **24a**, **25a** corresponding to the positive output) is excluded or disabled. In this way, control at the common-mode control terminal **10a** is carried out only through the branches **23b**, **24b**, **25b** enabled and the corresponding (negative) output. The voltage offset of this output as a result of the input signal I_{IN+} is reduced, enabling an accurate reading of the current in the load.

[0059] Illustrated in FIG. 7 is a different embodiment. In this case, a class D audio amplifier **107** comprises the chain of amplifier stages **8**, the PWM control stage **10**, the first PWM modulator **11a**, the second PWM modulator **11b**, the differential feedback-control network **12** and the common-mode feedback-control network **13** already described with reference to FIGS. 2-6. Furthermore, the audio amplifier **107** comprises a selective-enabling stage **155** and a clipping-detector stage **156**. The selective-enabling stage **155** comprises a first switch **155a** and a second switch **155b**, which are arranged along the branch **23a** and along the branch **23b**, respectively, of the clipping control loop **23** for enabling and disabling alternatively the clipping control loop **23** as a function of the response of the clipping-detector stage **156**. More precisely, the first switch **155a** is arranged between the negative output of the PWM control stage **10** and the impedance Z_{CM+} and the second switch **155b** is arranged between the positive output of the PWM control stage **10** and the impedance Z_{CM-} .

[0060] The clipping-detector stage **156** has inputs coupled to the first PWM modulator **11a** and to the second PWM modulator **11b**, respectively and is configured to detect conditions of saturation of one and/or the other, i.e., conditions where the output of the first PWM modulator **11a** and/or of the second PWM modulator **11b** is given by control signals with maximum duty cycle (for example, 100%). An output of the clipping-detector stage **156** simultaneously controls the first switch **155a** and the second switch **155b** by an enable signal S_{EN} . In conditions of clipping of the first PWM modulator **11a** and/or of the second PWM modulator **11b**, the clipping-detector stage **156** sets the enable signal S_{EN} to an enabling value, which causes closing of the first switch **155a** and of the second switch **155b** and enables operation of the clipping control loop **23**.

Instead, in normal operating conditions of the first PWM modulator **11a** and of the second PWM modulator **11b**, the clipping-detector stage **156** sets the enable signal S_{EN} to a disabling value, which causes opening of the first switch **155a** and of the second switch **155b** and inhibits operation of the clipping control loop **23**. In this way, the clipping control loop **23** is used exclusively when the remaining portion of the common-mode feedback-control network **13** is not in a condition to guarantee proper common-mode control of the PWM driving stage **10** on account of clipping.

[0061] In one embodiment (illustrated in FIG. **8**), in an audio amplifier **207** the inner control loop **24** may be missing, for example when the outer control loop **25** has a sufficiently high d.c. gain and is at the same time able to ensure adequate stability.

[0062] FIG. **9** shows a further embodiment. In this case, in an audio amplifier **307** the outer control loop **25** is missing and common-mode control of the PWM driving stage **10** is entrusted to the inner control loop **24** in ordinary operating conditions and to the clipping control loop **23** in conditions of clipping of the first PWM modulator **11a** and/or of the second PWM modulator **11b**. Furthermore, as for the inner control loop **24**, also the differential feedback-control network **12** may pick up the feedback signals at output from the PWM modulators **11a**, **11b** upstream of the output filters **16a**, **16b**.

[0063] Finally, it is evident that modifications and variations may be made to the amplifier and to the method described herein, without thereby departing from the scope of the present invention, as defined in the annexed claims.

What is claimed is:

1. A Class-D amplifier comprising:
 - a first fully-differential amplifier having differential inputs configured to receive an input signal;
 - a PWM control stage coupled to the first fully-differential amplifier and having a common-mode input, wherein the PWM control stage comprises a low-pass filter coupled between the common-mode input of the PWM control stage and a first output of the PWM control stage;
 - a first half-bridge coupled between the PWM control stage and a first output node; and
 - a second half-bridge coupled between the PWM control stage and a second output node, wherein the PWM control stage is configured to control the first half-bridge and the second half-bridge,
 - an input of the first half-bridge is coupled to the common-mode input of the PWM control stage via a first impedance,
 - an input of the second half-bridge is coupled to the common-mode input of the PWM control stage via a second impedance,
 - the first output node is coupled to the common-mode input of the PWM control stage via a third impedance, and
 - the second output node is coupled to the common-mode input of the PWM control stage via a fourth impedance.
2. The Class-D amplifier of claim **1**, further comprising a second fully-differential amplifier coupled between the first fully-differential amplifier and the PWM control stage.
3. The Class-D amplifier of claim **1**, further comprising:
 - a first output filter coupled to the first output node;
 - a second output filter coupled to the second output node; and
 - a load coupled between the first output filter and the second output filter.
4. The Class-D amplifier of claim **3**, wherein
 - a first terminal of the load is coupled to the common-mode input of the PWM control stage via a fifth impedance; and
 - a second terminal of the load is coupled to the common-mode input of the PWM control stage via a sixth impedance.
5. The Class-D amplifier of claim **1**, wherein the PWM control stage further comprises:
 - a first control amplifier coupled to the first output of the PWM control stage;
 - a second control amplifier coupled to a second output of the PWM control stage; and
 - an error amplifier coupled between the low-pass filter and the first and second control amplifiers.
6. The Class-D amplifier of claim **1**, further comprising:
 - a first comparator coupled between the PWM control stage and the first half-bridge;
 - a second comparator coupled between the PWM control stage and the second half-bridge; and
 - a reference generator coupled to the first and second comparators.
7. The Class-D amplifier of claim **6**, wherein the reference generator is configured to generate a triangular signal.
8. The Class-D amplifier of claim **1**, further comprising:
 - a first switch coupled between the input of the first half-bridge and the first impedance;
 - a second switch coupled between the input of the second half-bridge and the second impedance; and
 - a clipping detector coupled to the first switch and the second switch.
9. The Class-D amplifier of claim **8**, wherein the clipping detector is configured to turn on the first switch and the second switch when a clipping event occurs.
10. A method of controlling a Class-D amplifier, the method comprising:
 - receiving an input signal with a first fully-differential amplifier;
 - generating a first and second PWM signals with a PWM control stage based on differential outputs of the fully differential amplifier;
 - controlling a first half-bridge with the first PWM signal;
 - controlling a second half-bridge with the second PWM signal; and
 - setting a common-mode of the PWM control stage based on a feedback node, wherein the setting the common-mode of the PWM control stage comprises
 - receiving the first PWM signal at the feedback node via a first impedance,
 - receiving the second PWM signal at the feedback node via a second impedance,
 - receiving a first signal from an output of the first half-bridge at the feedback node via a third impedance,
 - receiving a second signal from an output of the second half-bridge at the feedback node via a fourth impedance, and

- low-pass filtering a signal from the feedback node with a low-pass filter.
- 11.** The method of claim **10**, wherein the setting the common-mode of the PWM control stage further comprises: receiving a third signal from a first output filter coupled to the first half-bridge at the feedback node via a fifth impedance; and receiving a fourth signal from a second output filter coupled to the second half-bridge at the feedback node via a sixth impedance.
- 12.** The method of claim **10**, wherein the first PWM signal and the second PWM signal correspond to an in-phase modulation scheme.
- 13.** The method of claim **10**, wherein the first PWM signal and the second PWM signal correspond to an out-of-phase modulation scheme.
- 14.** The method of claim **10**, wherein the low-pass filter has a cut-off frequency lower than a switching frequency of the first PWM signal.
- 15.** The method of claim **10**, further comprising: detecting a clipping event; closing a first switch coupled between a first output of the PWM control stage and the first impedance after detecting the clipping event; and closing a second switch coupled between a second output of the PWM control stage and the second impedance after detecting the clipping event.
- 16.** The method of claim **15**, wherein detecting the clipping event comprises: determining that the output of the first half-bridge has a 100% duty cycle; or determining that the output of the second half-bridge has a 100% duty cycle.
- 17.** The method of claim **15**, further comprising opening the first and second switches during an absence of the clipping event.
- 18.** A Class-D audio amplifier comprising: a first fully-differential amplifier stage configured to receive an audio signal;
- a fully-differential PWM control stage comprising differential inputs coupled to differential outputs of the first fully-differential amplifier; and a low-pass filter coupled between a common-mode input of the fully-differential PWM control stage and a first and second differential outputs of the fully-differential PWM control stage;
- a first half-bridge coupled between the first differential output of the fully-differential PWM control stage and a first output node; and
- a second half-bridge coupled between the second differential output of the fully-differential PWM control stage and a second output node, wherein the first differential output of the fully-differential PWM control stage is coupled to the common-mode input of the fully-differential PWM control stage via a first impedance, the second differential output of the fully-differential PWM control stage is coupled to the common-mode input of the fully-differential PWM control stage via a second impedance, the first output node is coupled to the common-mode input of the fully-differential PWM control stage via a third impedance, and the second output node is coupled to the common-mode input of the fully-differential PWM control stage via a fourth impedance.
- 19.** The Class-D audio amplifier of claim **18**, further comprising: a first output filter coupled to the first output node; a second output filter coupled to the second output node; and a loudspeaker coupled between the first output filter and the second output filter.
- 20.** The Class-D audio amplifier of claim **19**, wherein a first terminal of the loudspeaker is coupled to the common-mode input of the fully-differential PWM control stage via a fifth impedance; and a second terminal of the loudspeaker is coupled to the common-mode input of the fully-differential PWM control stage via a sixth impedance.

* * * * *