



(19) **United States**

(12) **Patent Application Publication**  
**Sannala**

(10) **Pub. No.: US 2018/0063485 A1**  
(43) **Pub. Date: Mar. 1, 2018**

(54) **SYSTEMS, METHODS, AND DEVICES FOR MANAGING COEXISTENCE OF MULTIPLE TRANSCEIVER DEVICES BY OPTIMIZING COMPONENT LAYOUT**

*H01Q 1/24* (2006.01)  
*H01Q 1/22* (2006.01)  
*G08B 25/10* (2006.01)  
*H04W 88/06* (2009.01)

(71) Applicant: **GOOGLE INC.**, Mountain View, CA (US)

(52) **U.S. Cl.**  
CPC ..... *H04N 7/18* (2013.01); *H04W 88/06* (2013.01); *G08B 17/10* (2013.01); *G08B 17/113* (2013.01); *G08B 25/007* (2013.01); *G08B 13/19619* (2013.01); *H04W 72/1215* (2013.01); *H04W 48/10* (2013.01); *H04W 48/02* (2013.01); *H04W 4/008* (2013.01); *H04N 5/33* (2013.01); *H04N 5/23206* (2013.01); *H04N 5/2256* (2013.01); *H04N 5/2254* (2013.01); *H04L 12/2836* (2013.01); *H04L 12/282* (2013.01); *H04L 12/2814* (2013.01); *H04L 12/2809* (2013.01); *H04B 1/3838* (2013.01); *H01Q 21/28* (2013.01); *H01Q 1/24* (2013.01); *H01Q 1/2291* (2013.01); *G08B 25/10* (2013.01); *G08B 25/009* (2013.01); *G08B 13/19636* (2013.01); *H04L 2012/2841* (2013.01); *H04L 2012/2849* (2013.01); *H04W 72/1242* (2013.01)

(72) Inventor: **Mikko Pekka Sannala**, Los Gatos, CA (US)

(21) Appl. No.: **15/691,663**

(22) Filed: **Aug. 30, 2017**

**Related U.S. Application Data**

(63) Continuation of application No. 15/085,927, filed on Mar. 30, 2016, now Pat. No. 9,794,522, which is a continuation-in-part of application No. 14/616,302, filed on Feb. 6, 2015, which is a continuation-in-part of application No. 14/819,373, filed on Aug. 5, 2015, now Pat. No. 9,396,633.

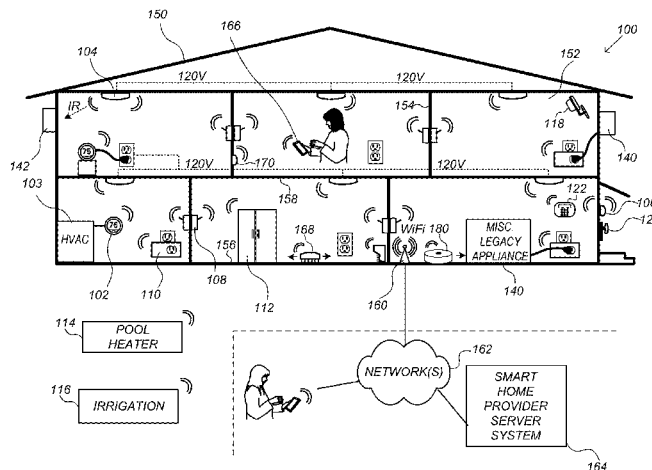
(60) Provisional application No. 62/175,393, filed on Jun. 14, 2015.

**Publication Classification**

(51) **Int. Cl.**  
*H04N 7/18* (2006.01)  
*H04W 72/12* (2009.01)  
*G08B 17/10* (2006.01)  
*G08B 17/113* (2006.01)  
*G08B 25/00* (2006.01)  
*G08B 13/196* (2006.01)  
*H04W 48/10* (2009.01)  
*H04W 48/02* (2009.01)  
*H04W 4/00* (2009.01)  
*H04N 5/33* (2006.01)  
*H04N 5/232* (2006.01)  
*H04N 5/225* (2006.01)  
*H04L 12/28* (2006.01)  
*H01Q 21/28* (2006.01)

(57) **ABSTRACT**

The various implementations disclosed herein include a camera assembly configured for communication over multiple communication protocols. The camera assembly includes: (1) an enclosed housing; (2) a lens module positioned within the enclosed housing and configured to receive light; (3) circuit board(s) positioned within the enclosed housing; (4) communication circuitry coupled to the circuit board(s) and configured to wirelessly communicate over a plurality of different communication protocols, the communication circuitry including one or more transceivers configured for communication over a first communication protocol and a second communication protocol; (5) a first antenna arranged at a first location on the circuit board(s), the first antenna configured for communication over the first communication protocol; and (6) a second antenna arranged at a second location on the circuit board(s), the second antenna configured for communication over the second communication protocol.



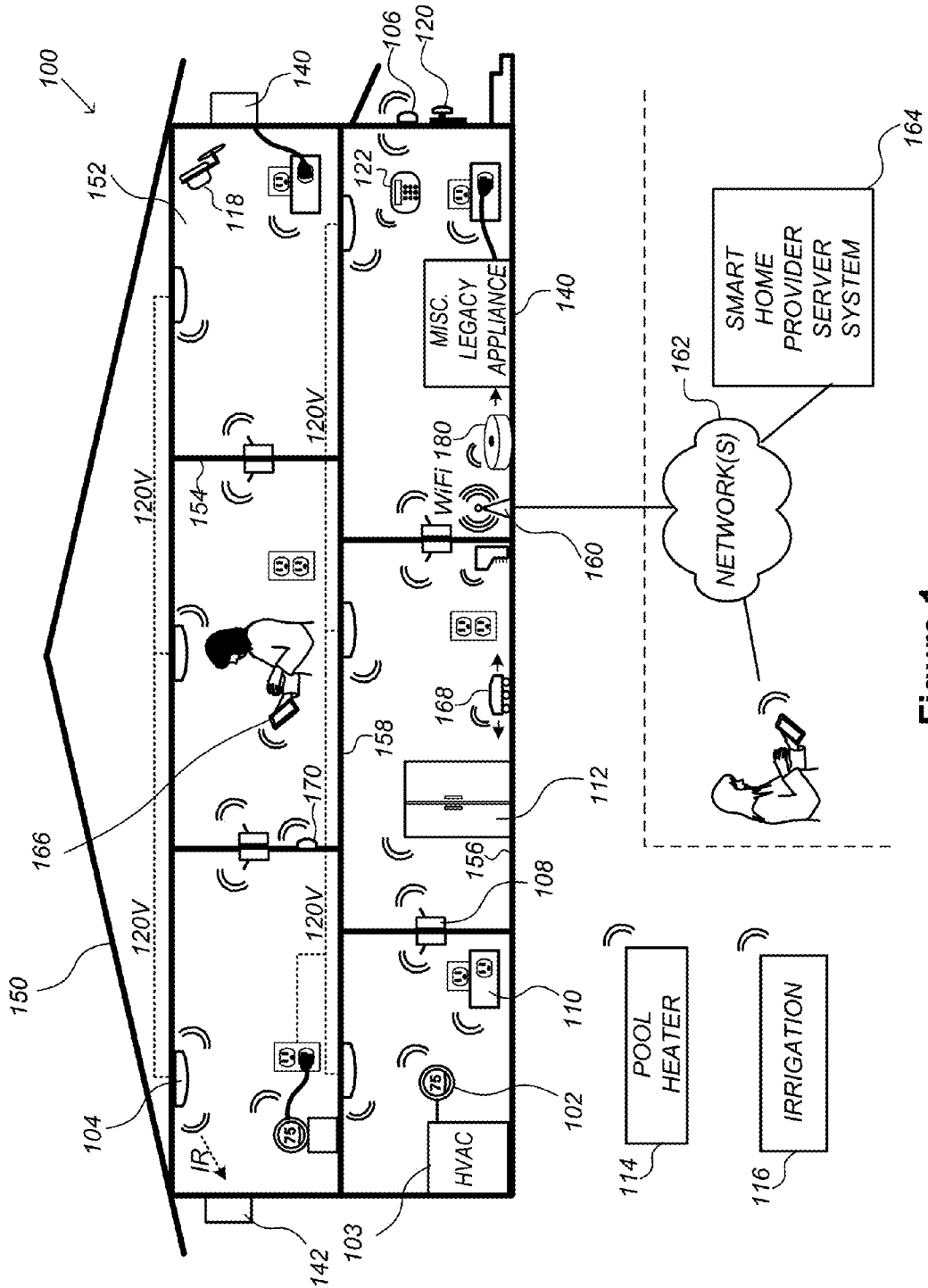


Figure 1

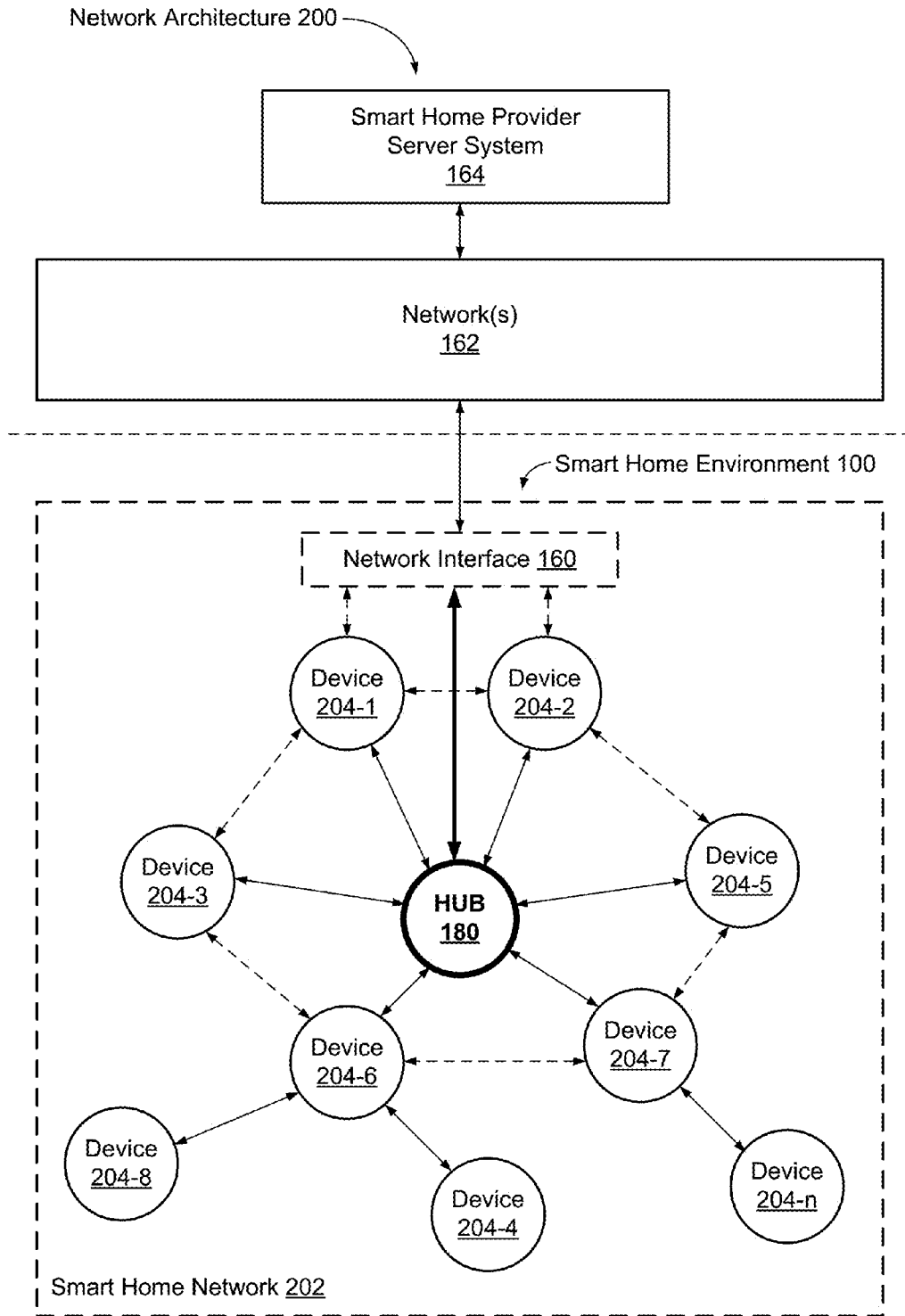


Figure 2

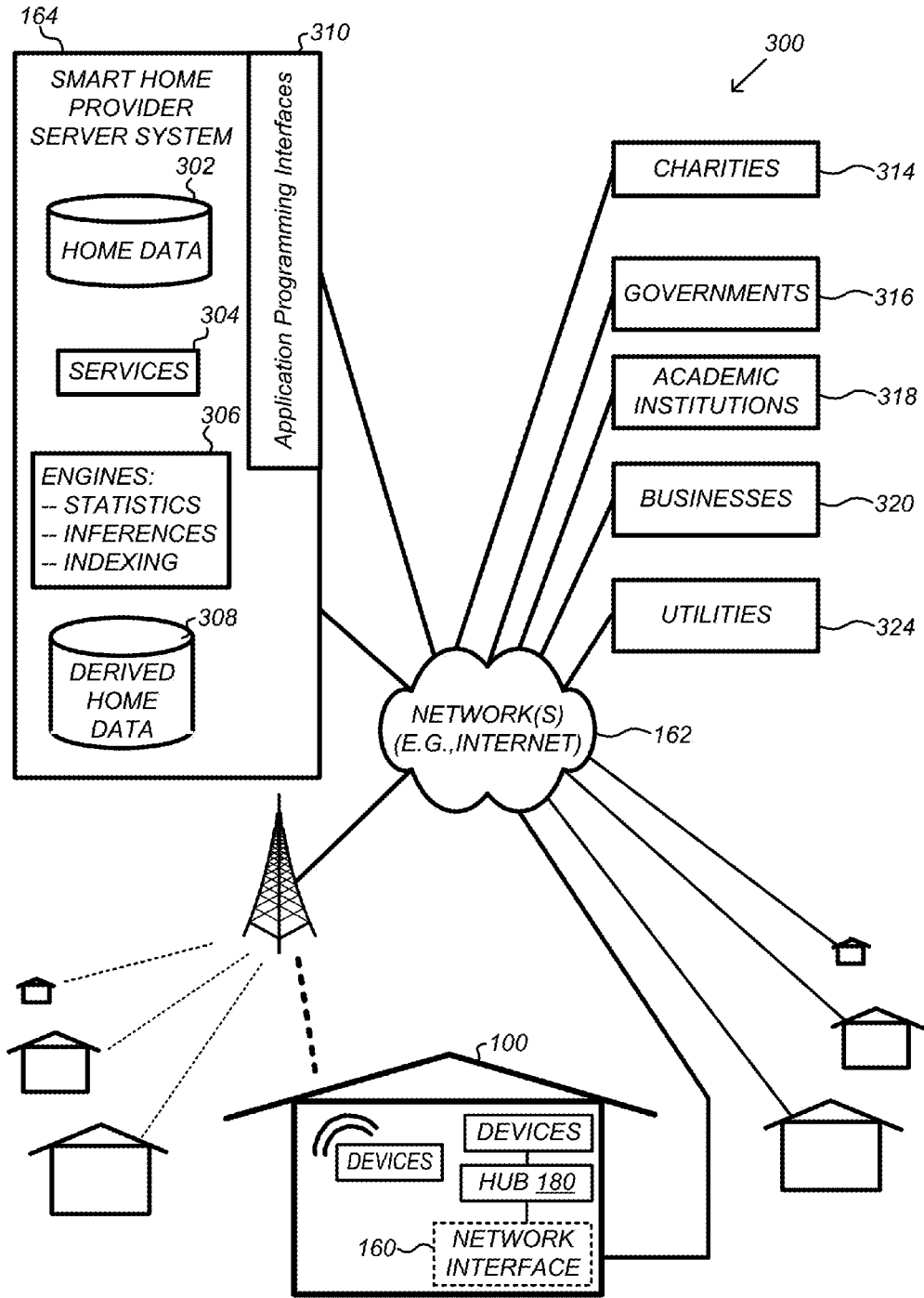


Figure 3

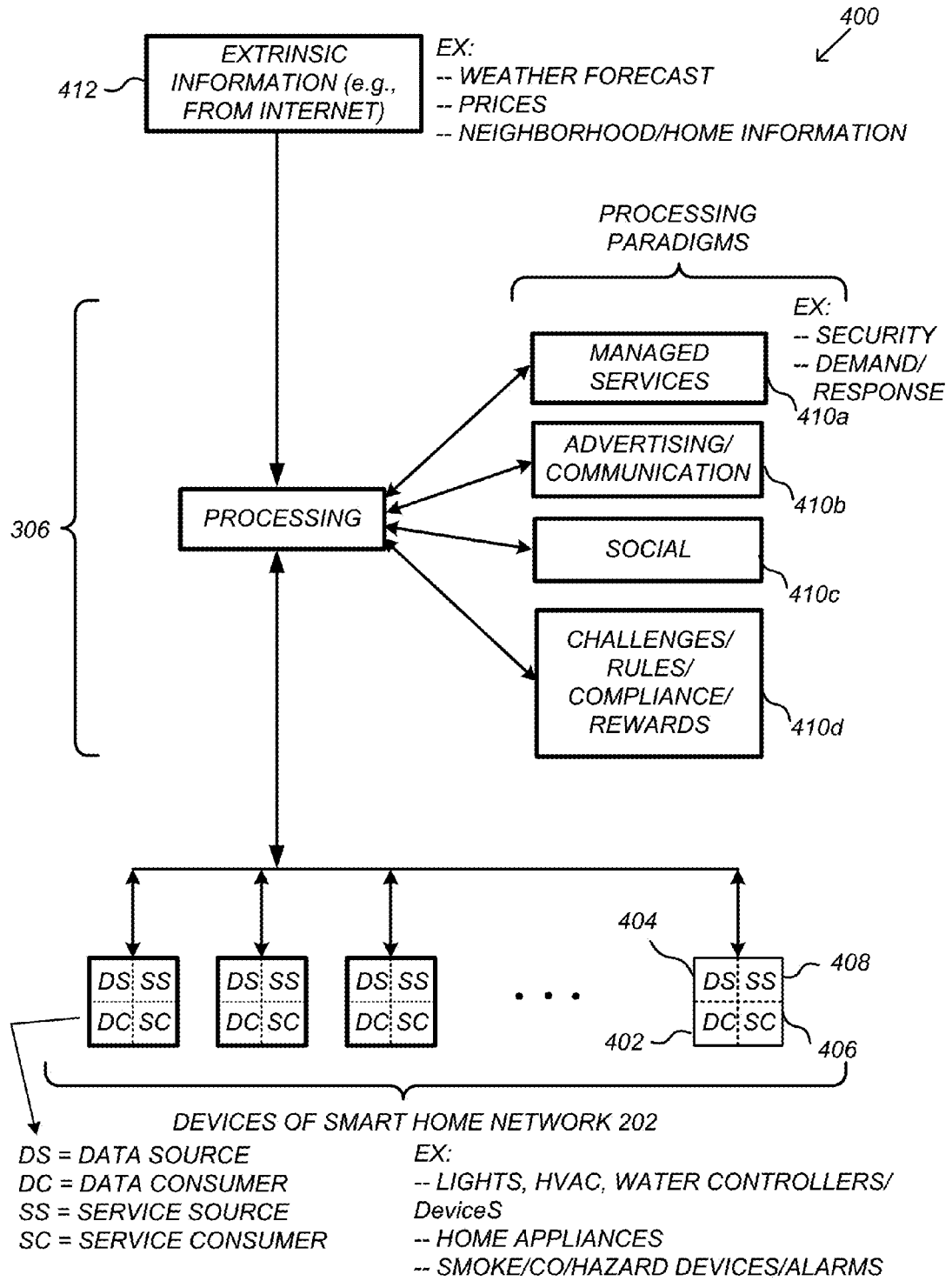


Figure 4

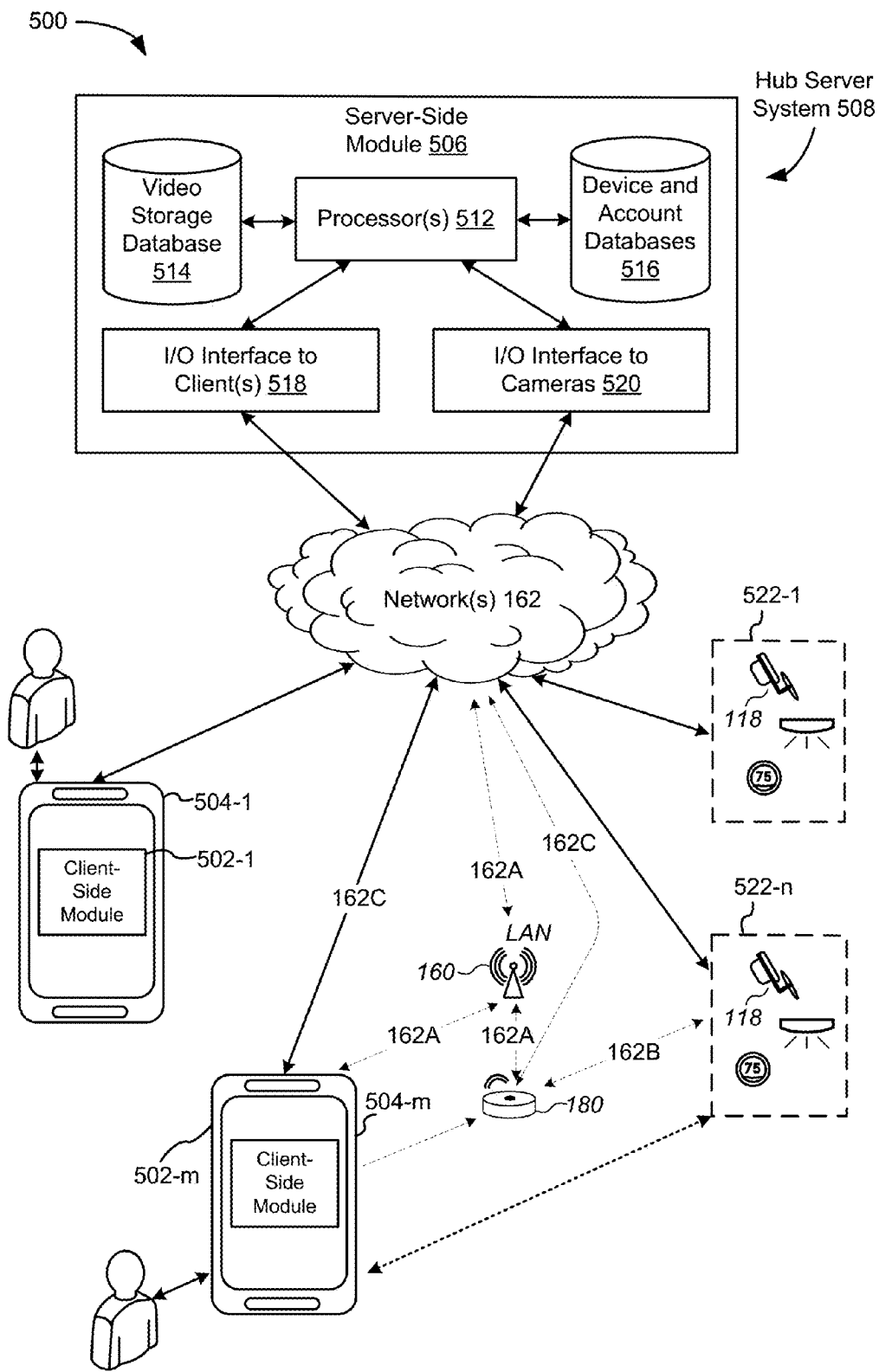


Figure 5

Hub Device 180

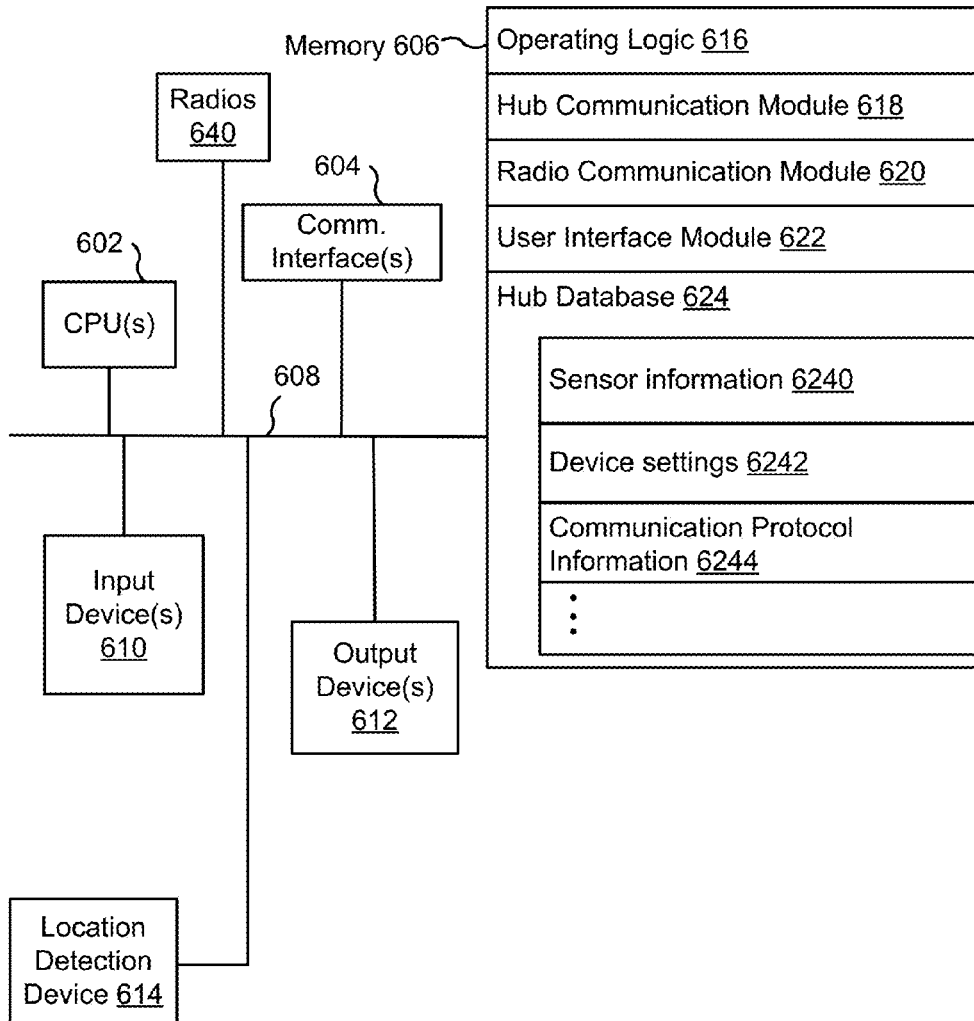
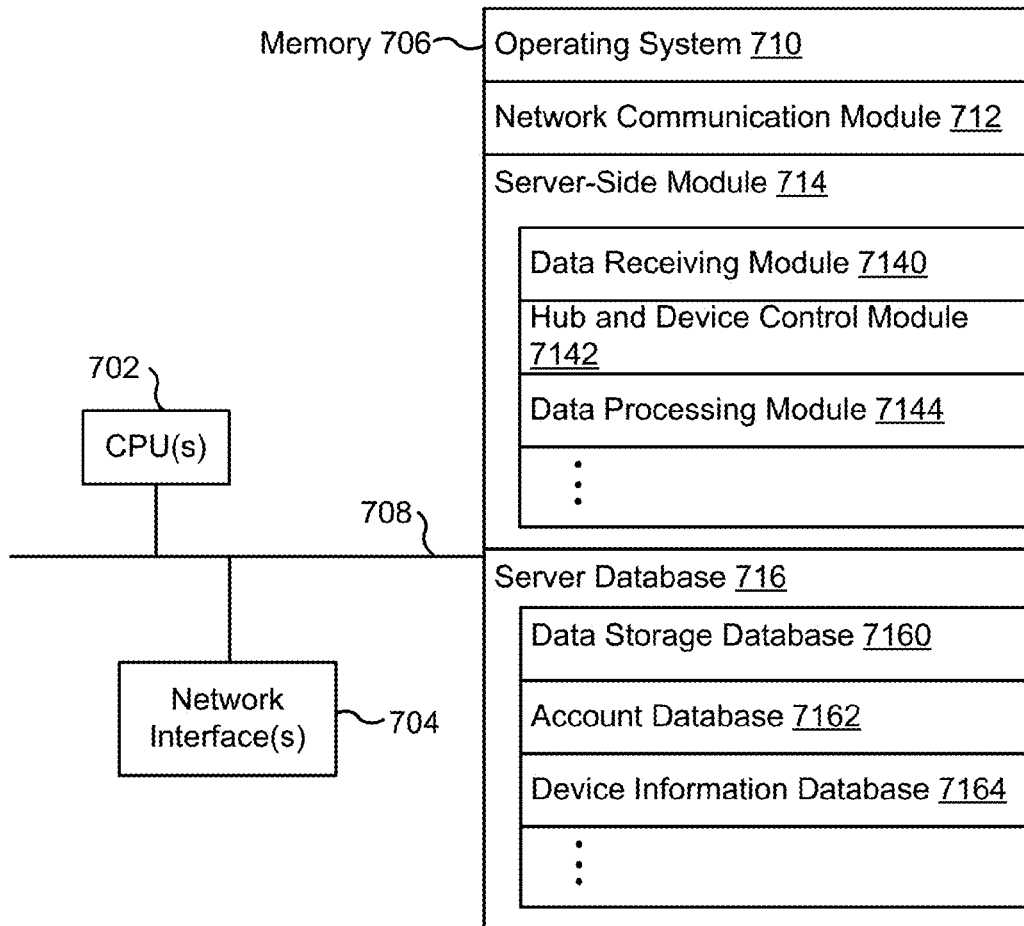


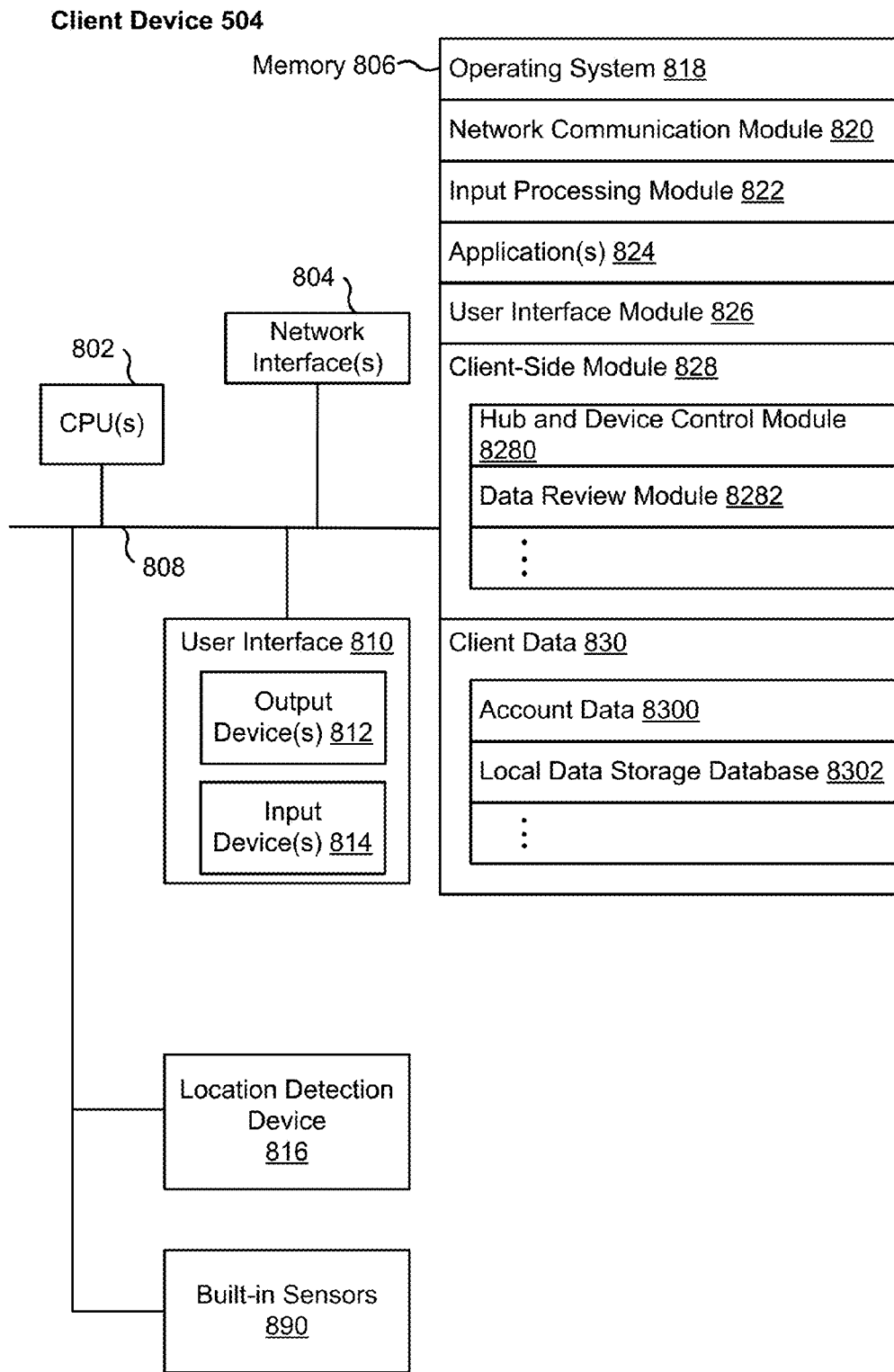
Figure 6

### Hub Server System 508

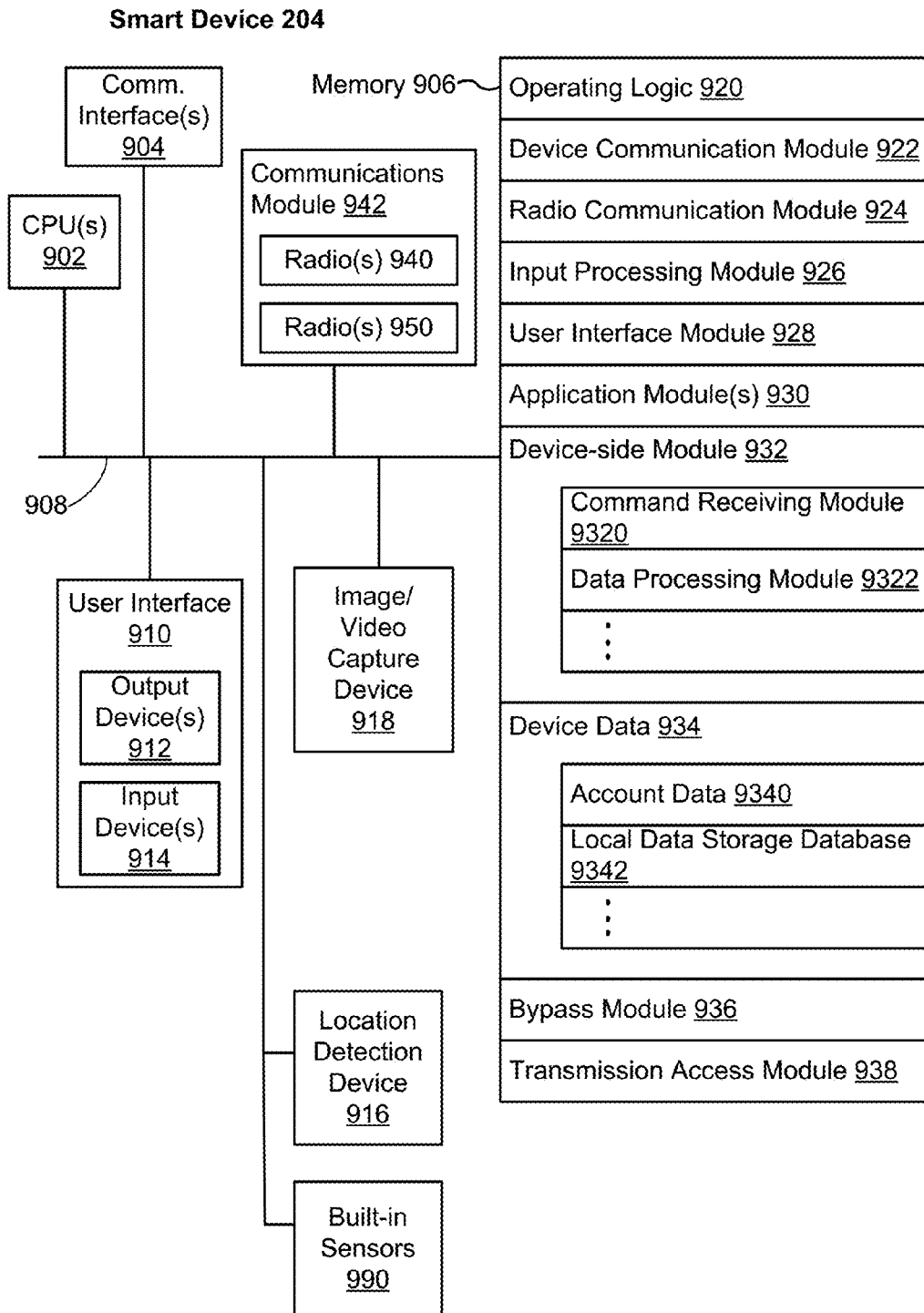


**Figure 7**



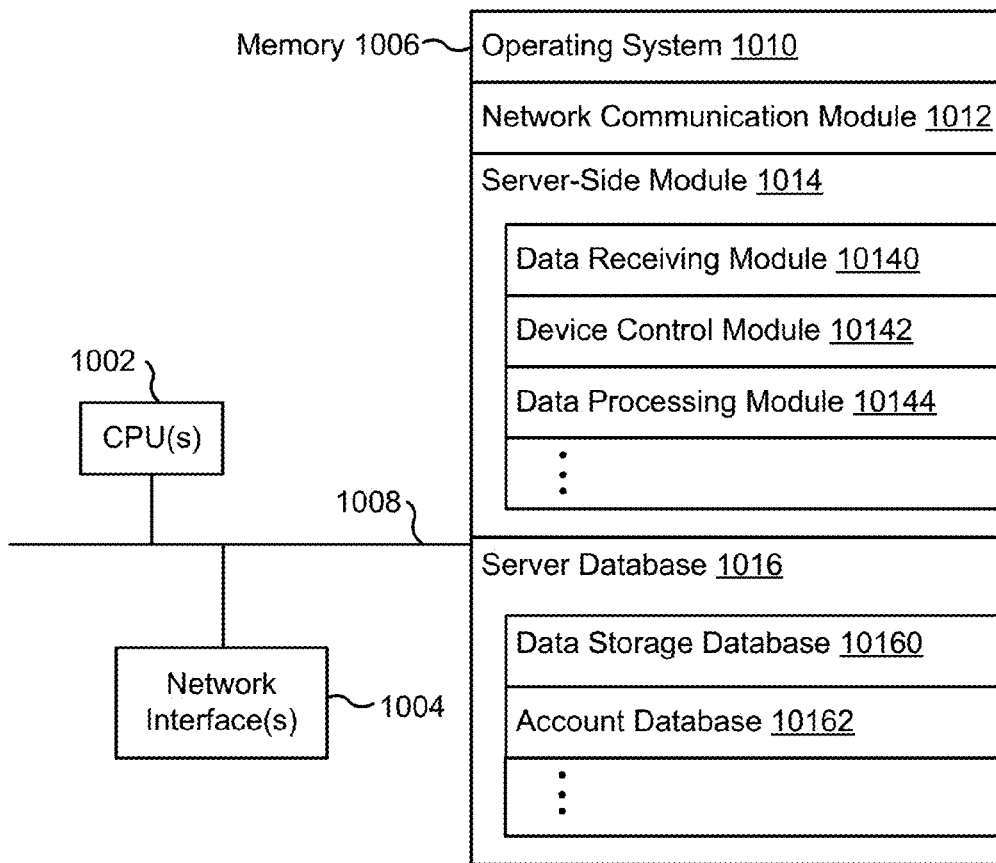


**Figure 8**



**Figure 9**

**Smart Home Provider  
Server System 164**



**Figure 10**

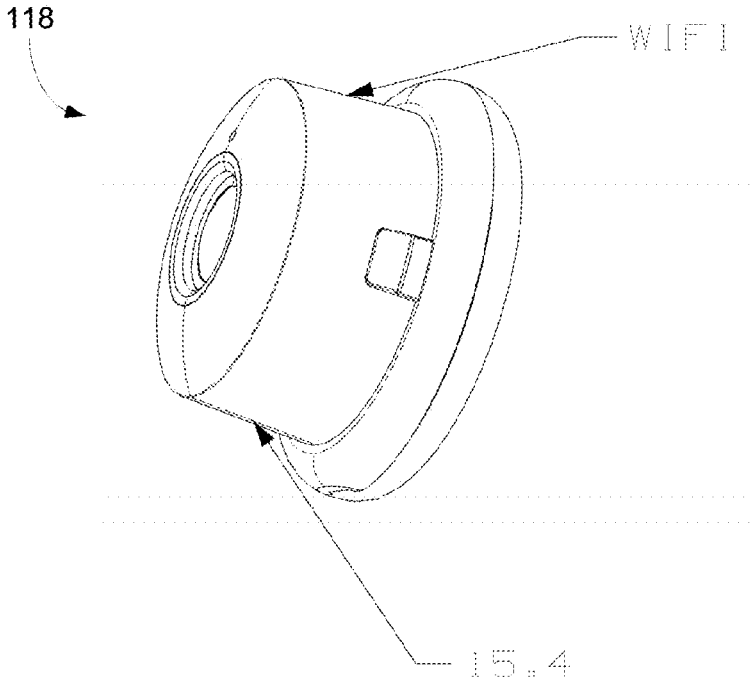


FIGURE 11A

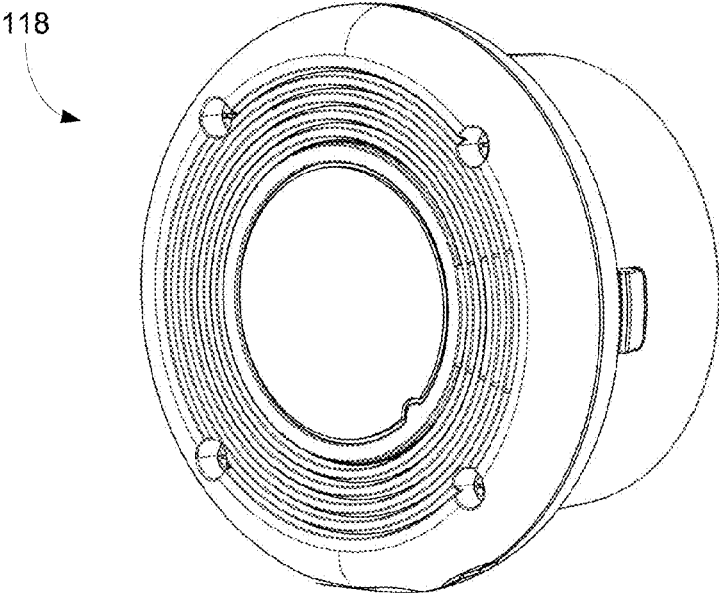


FIGURE 11B

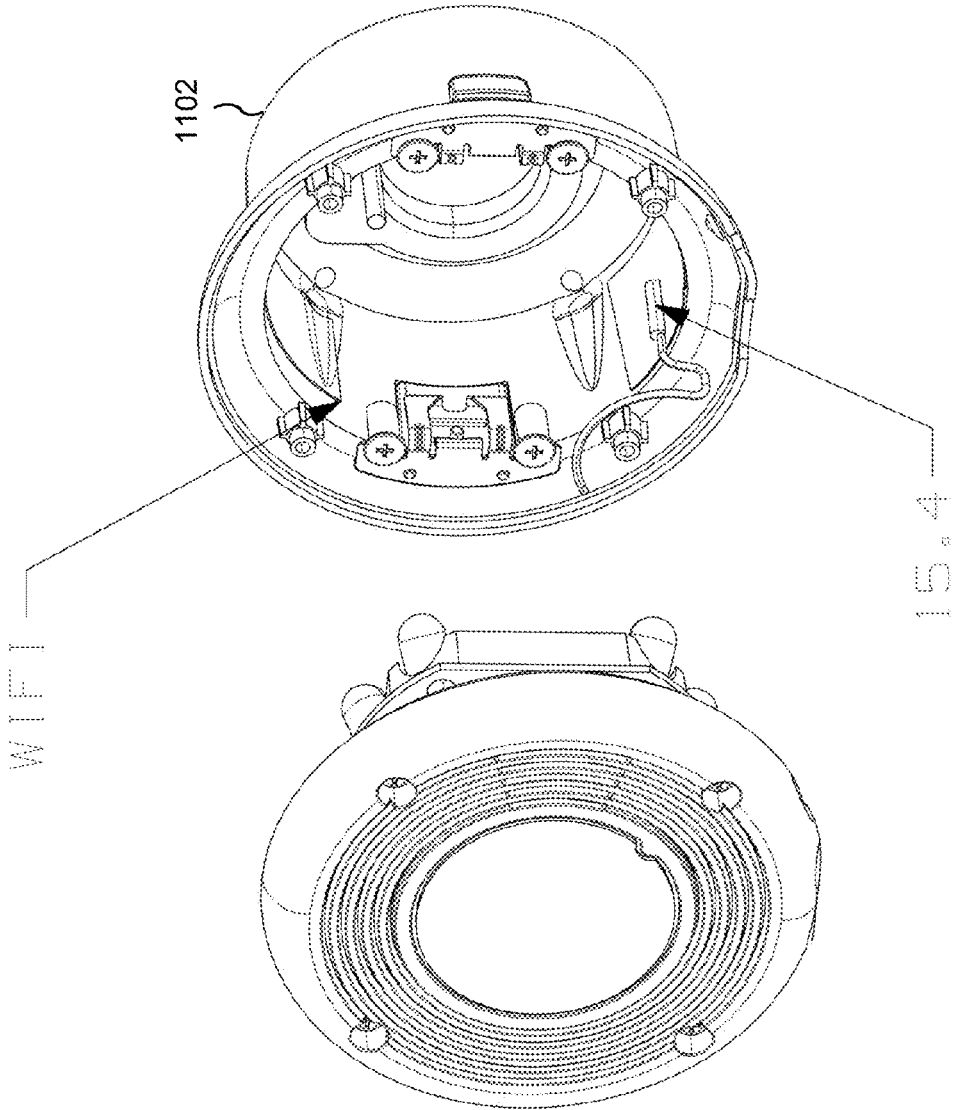
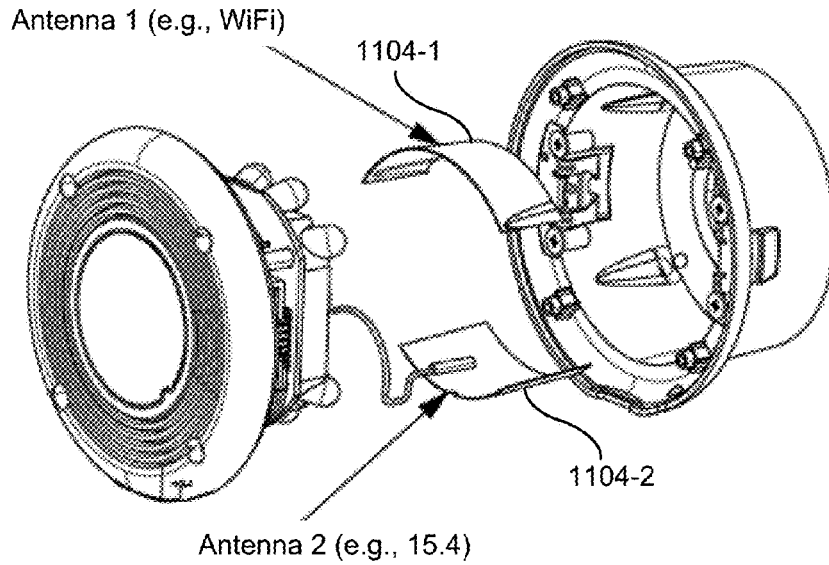
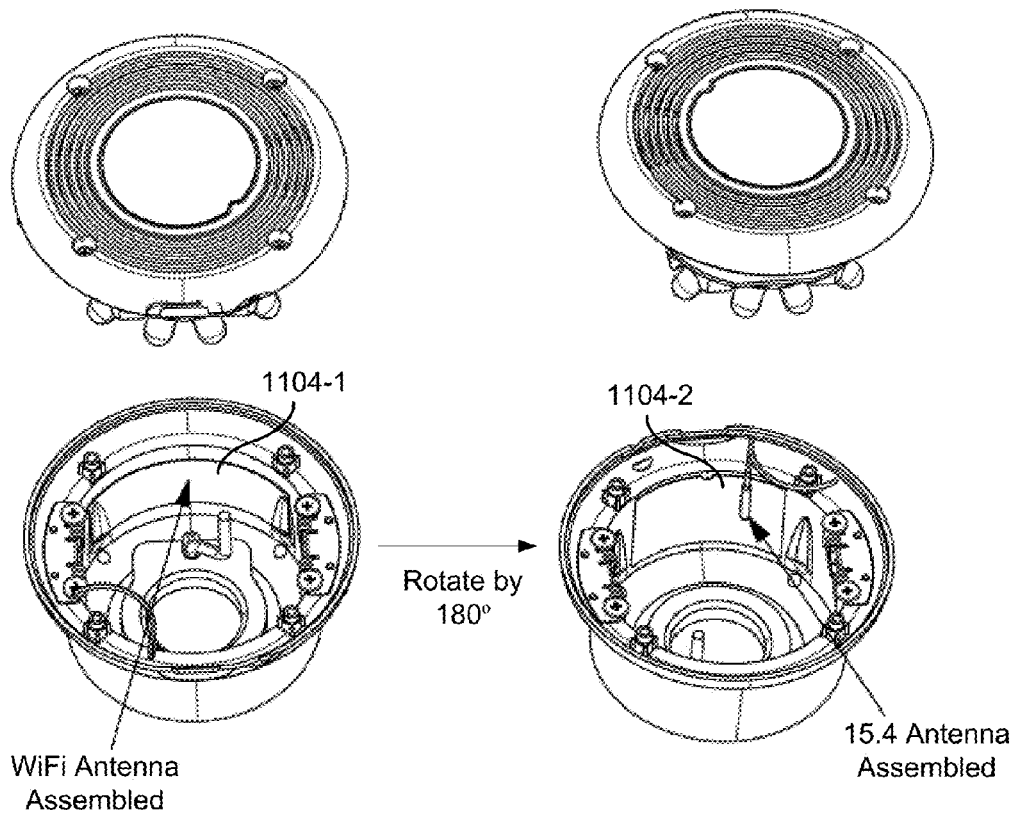


FIGURE 11C



**FIGURE 11D**



Antenna Placement inside  
the Camera Module

**FIGURE 11E**

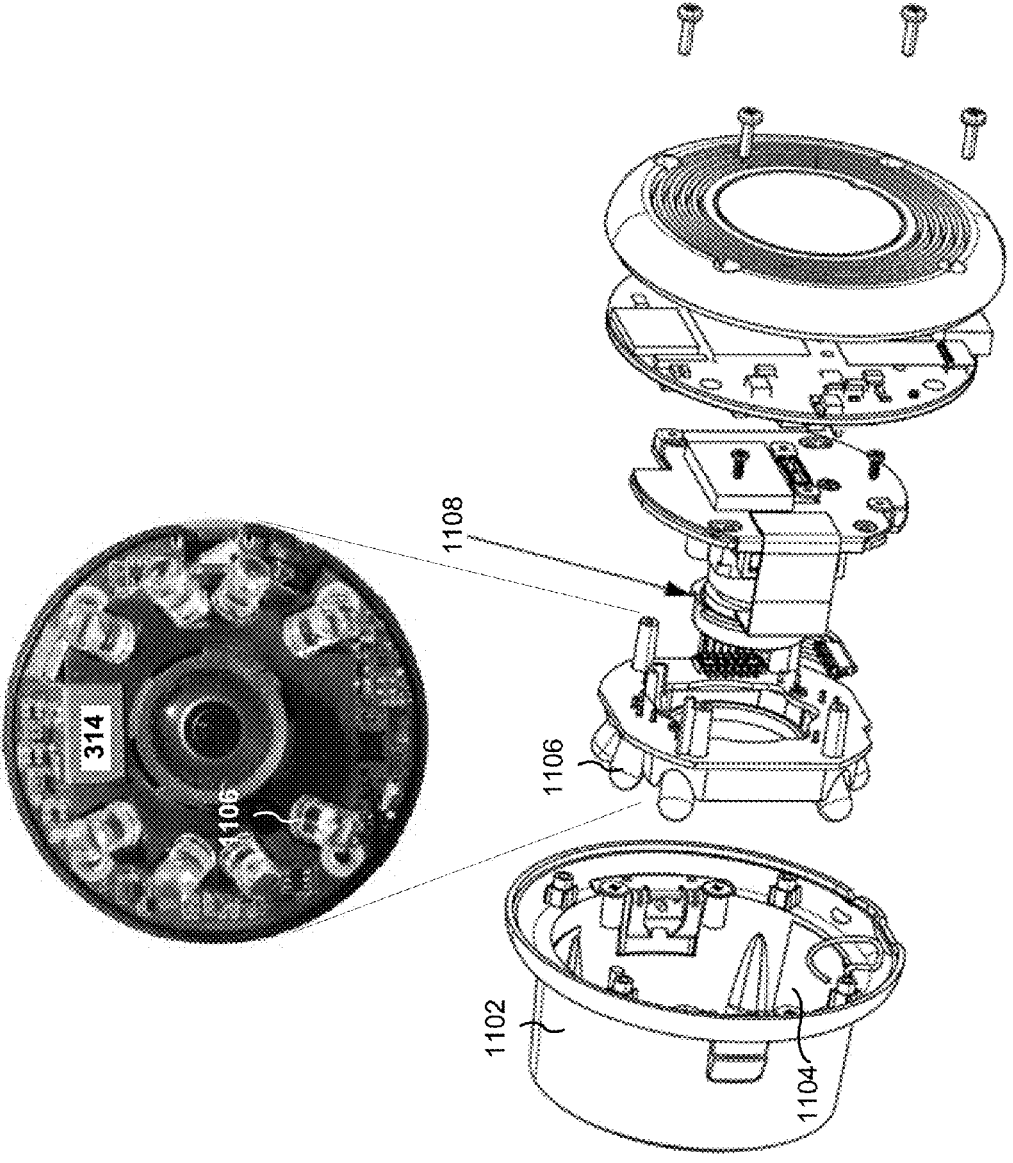


FIGURE 11F

118

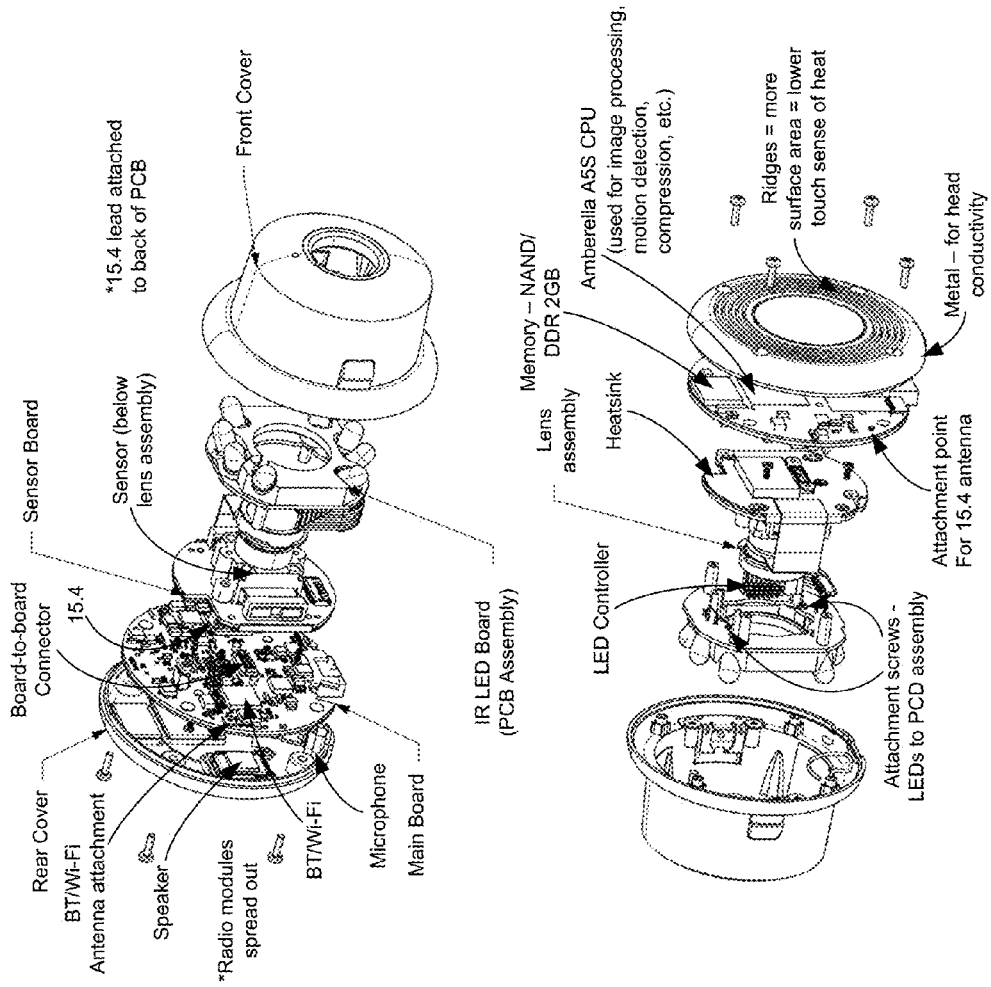


FIGURE 11G



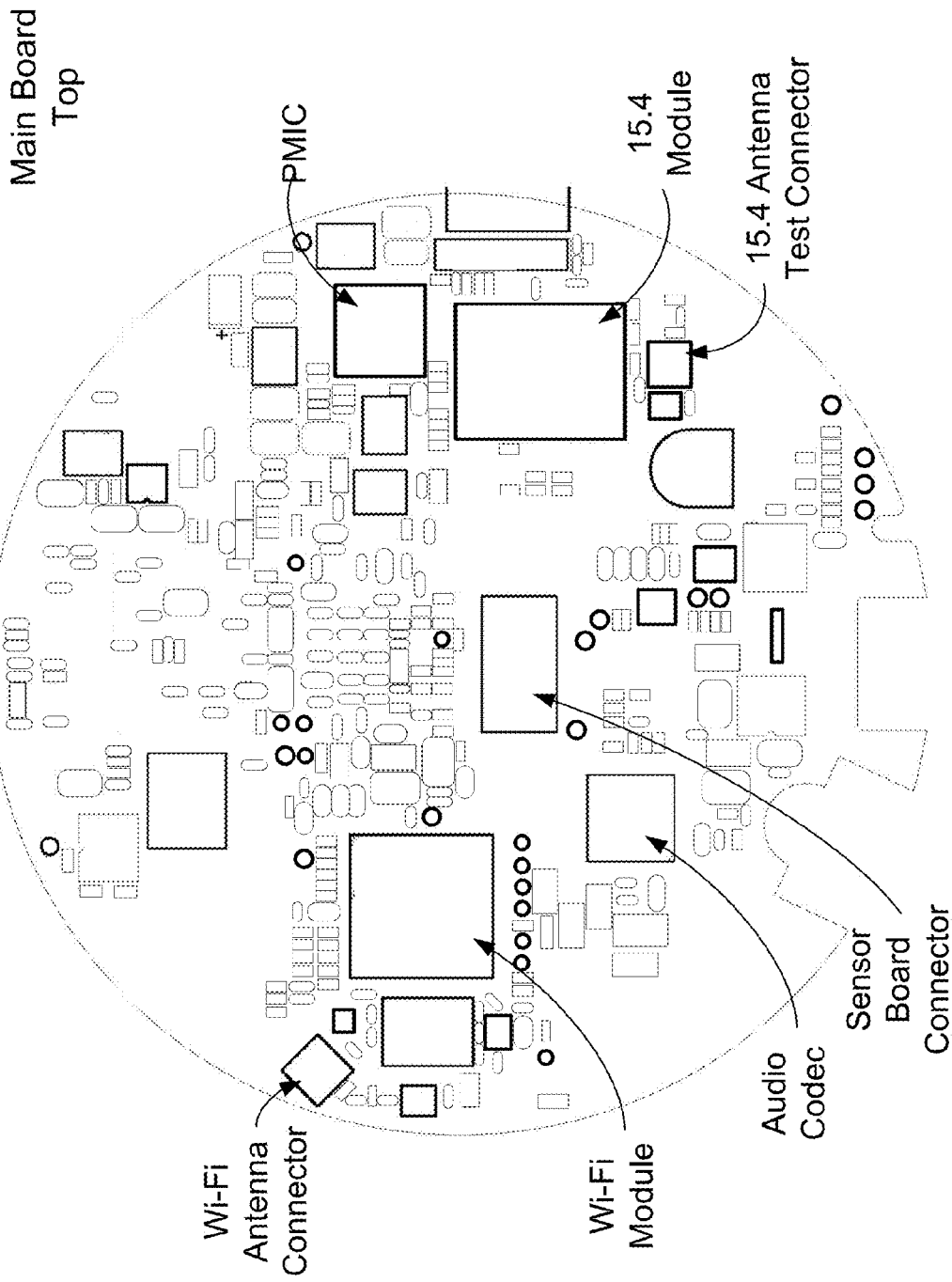
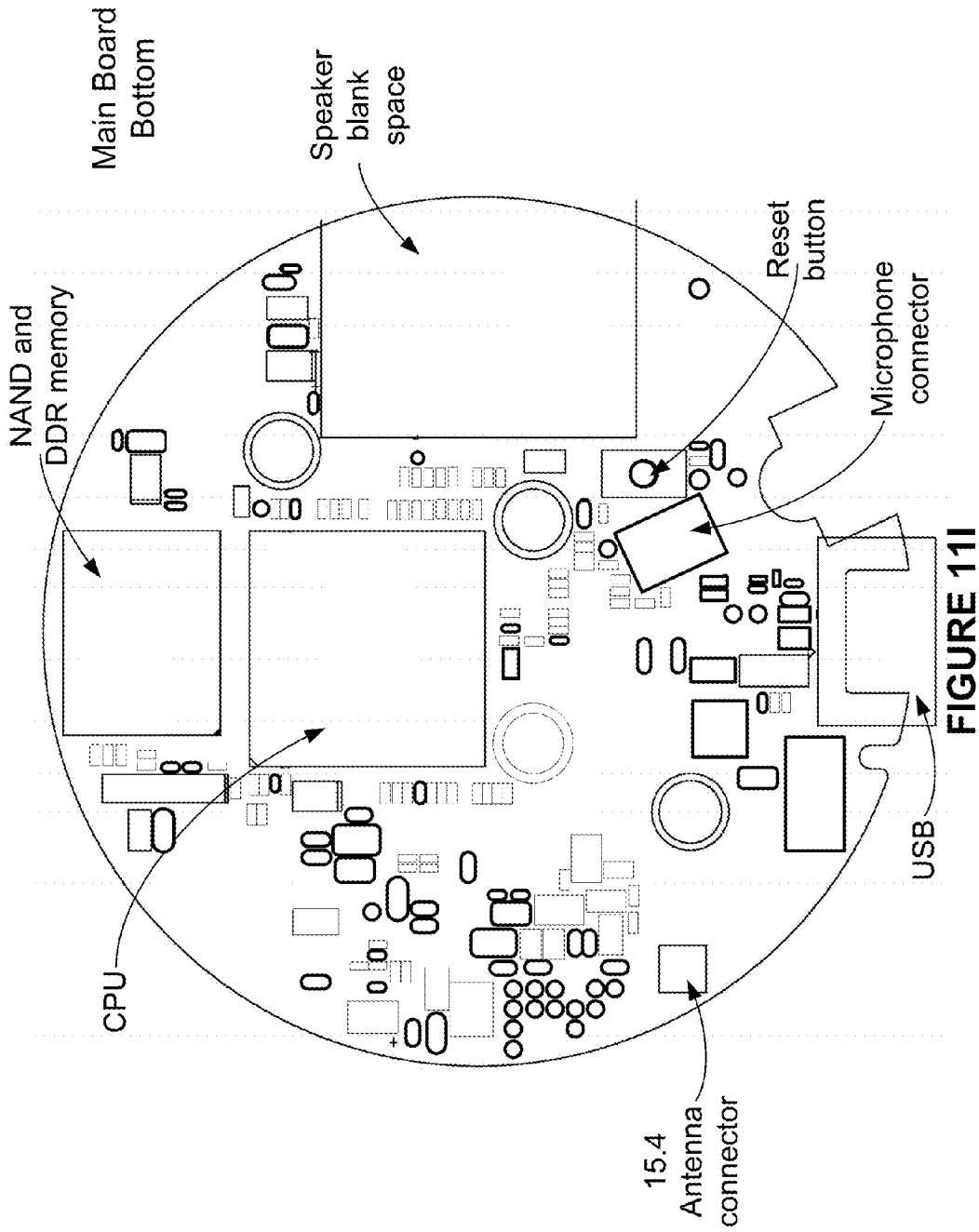
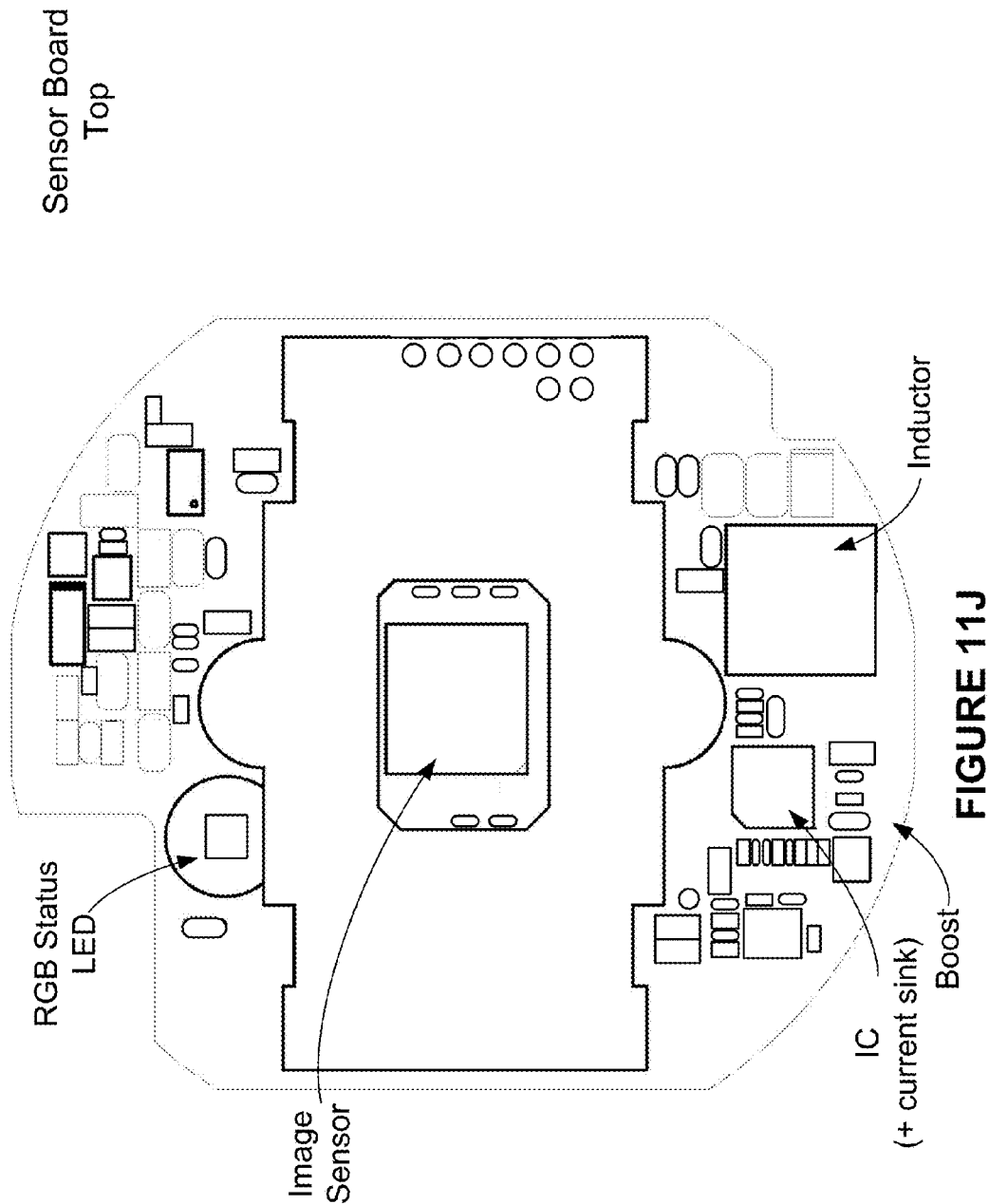


FIGURE 11H



**FIGURE 11I**



Sensor Board  
Bottom

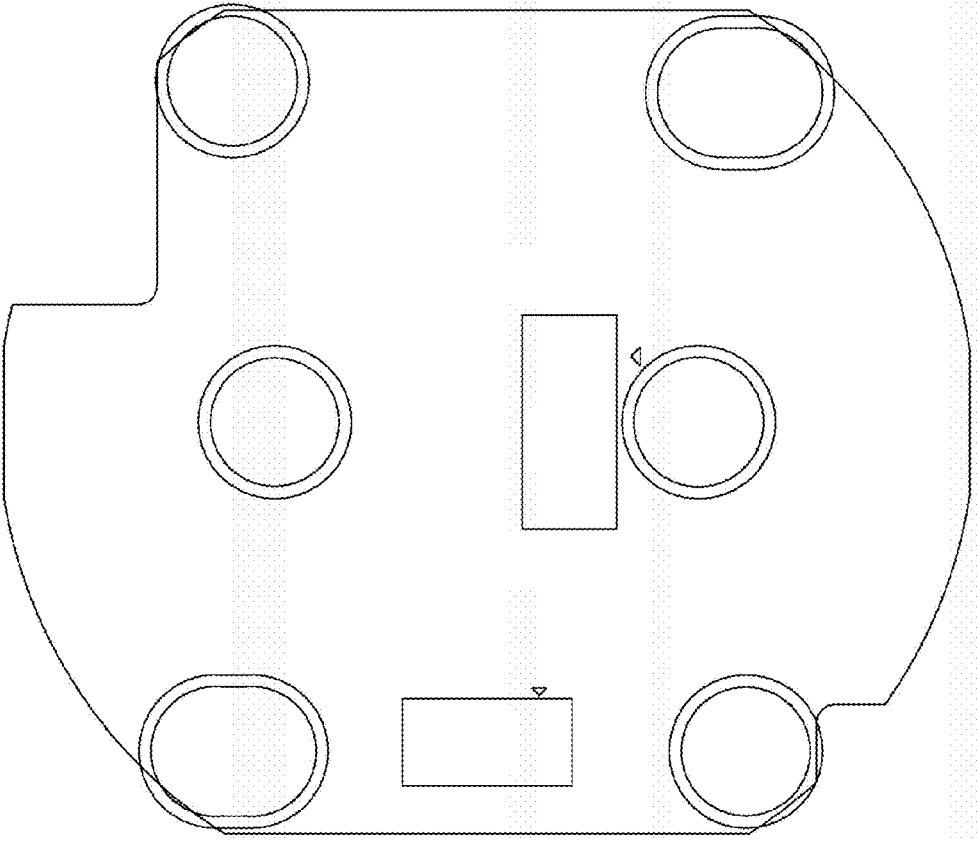


FIGURE 11K

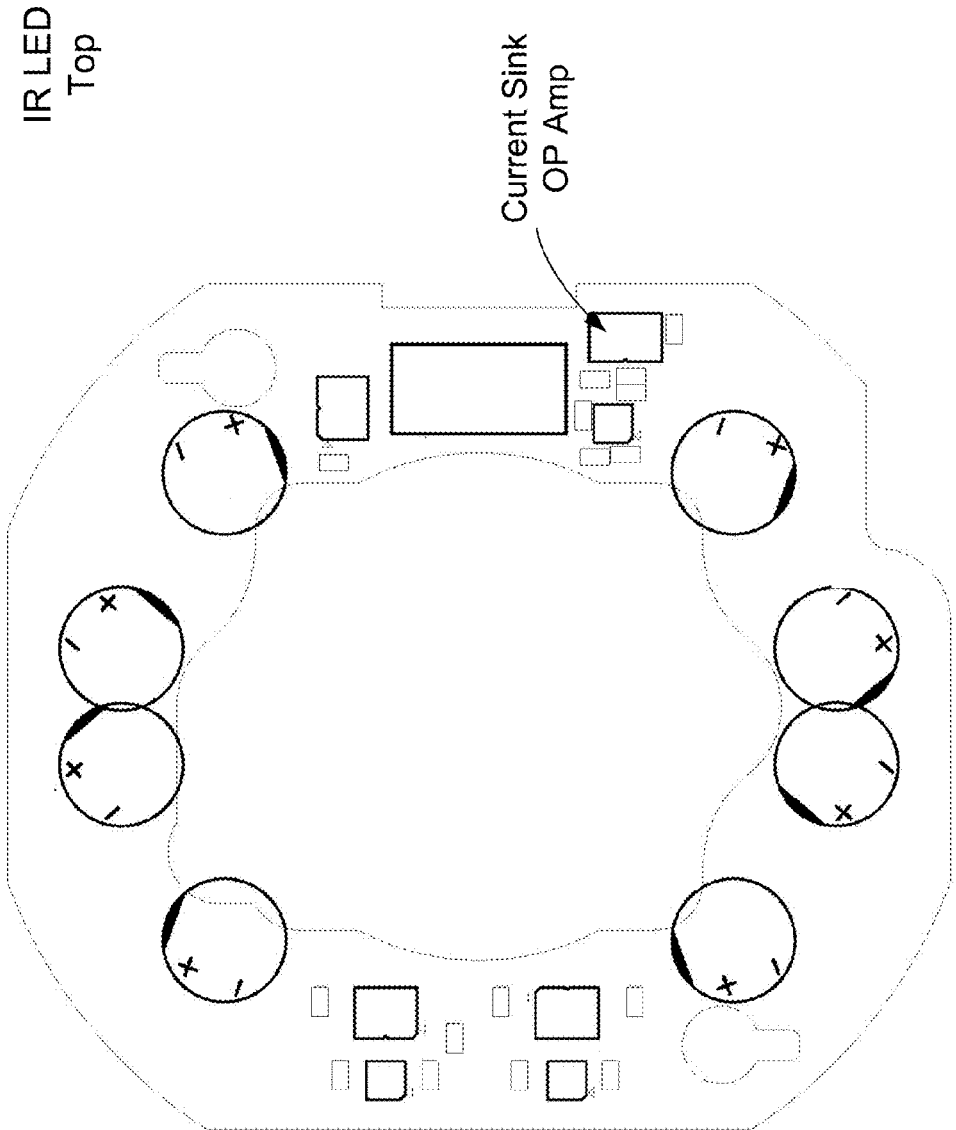
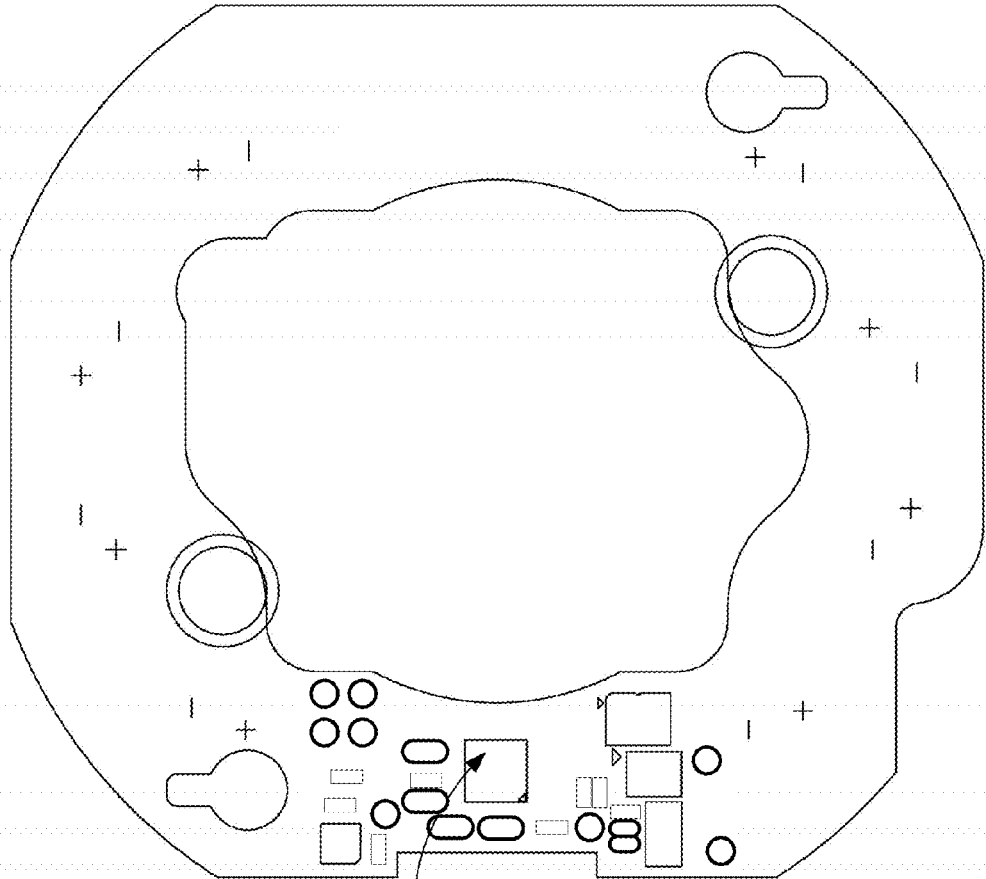


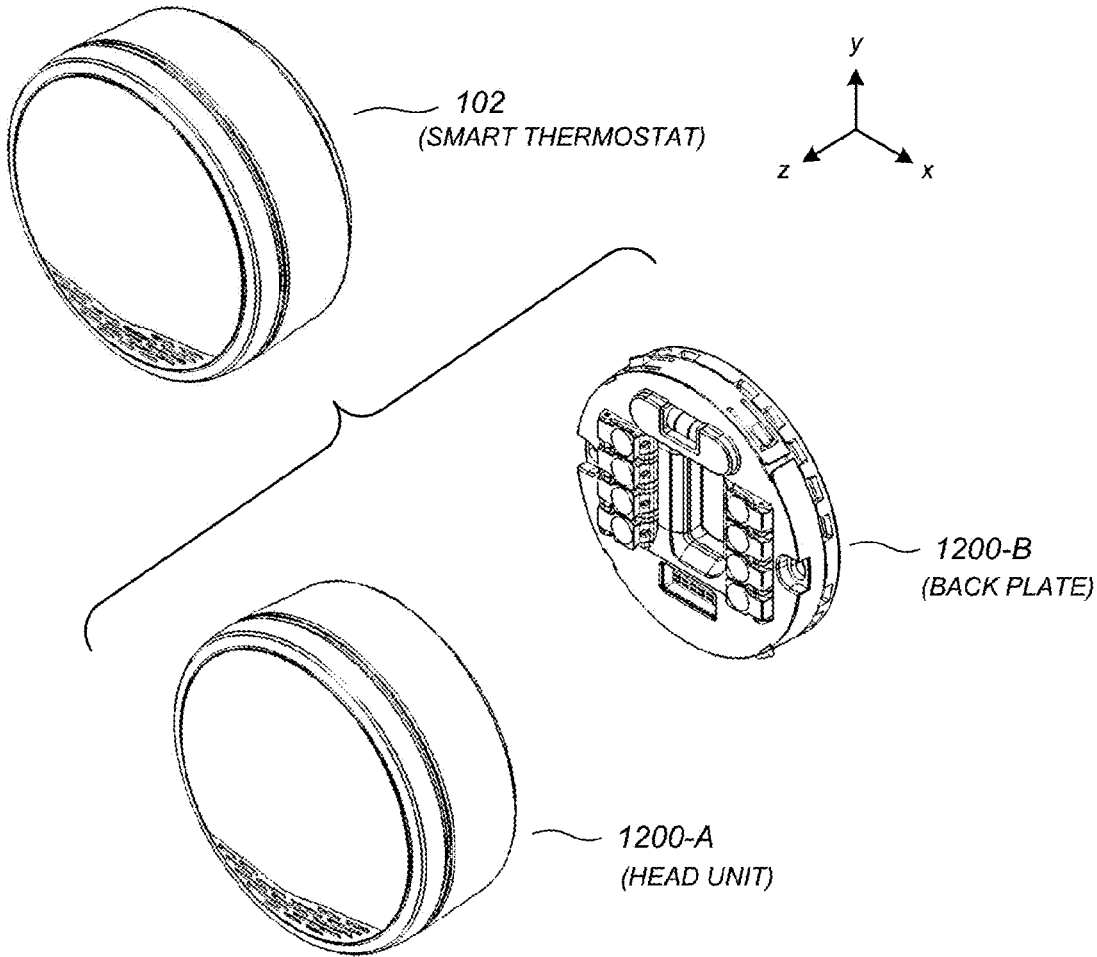
FIGURE 11L

IR LED  
Bottom



Depth Mode  
Controller IC

FIGURE 11M



**FIGURE 12A**

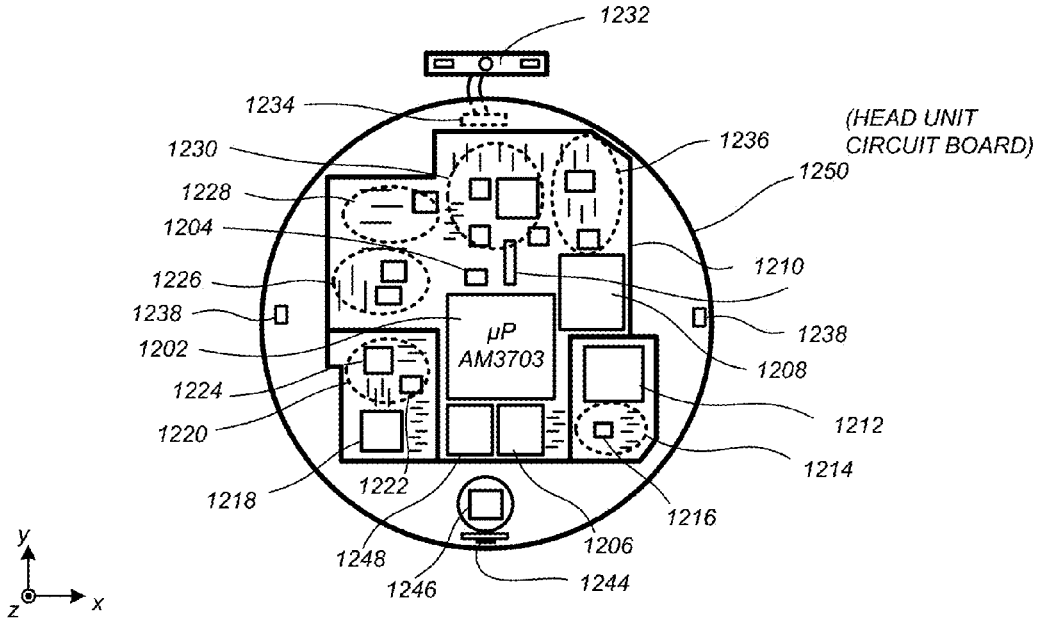


FIGURE 12B

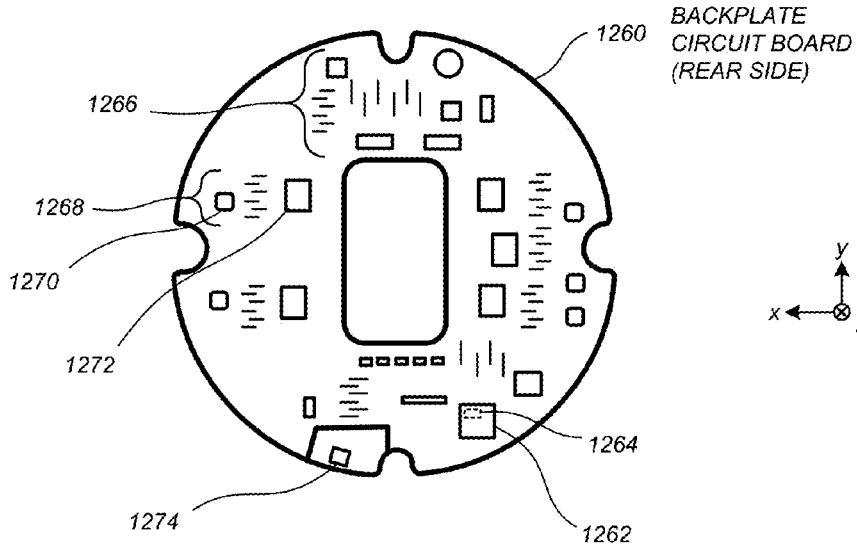
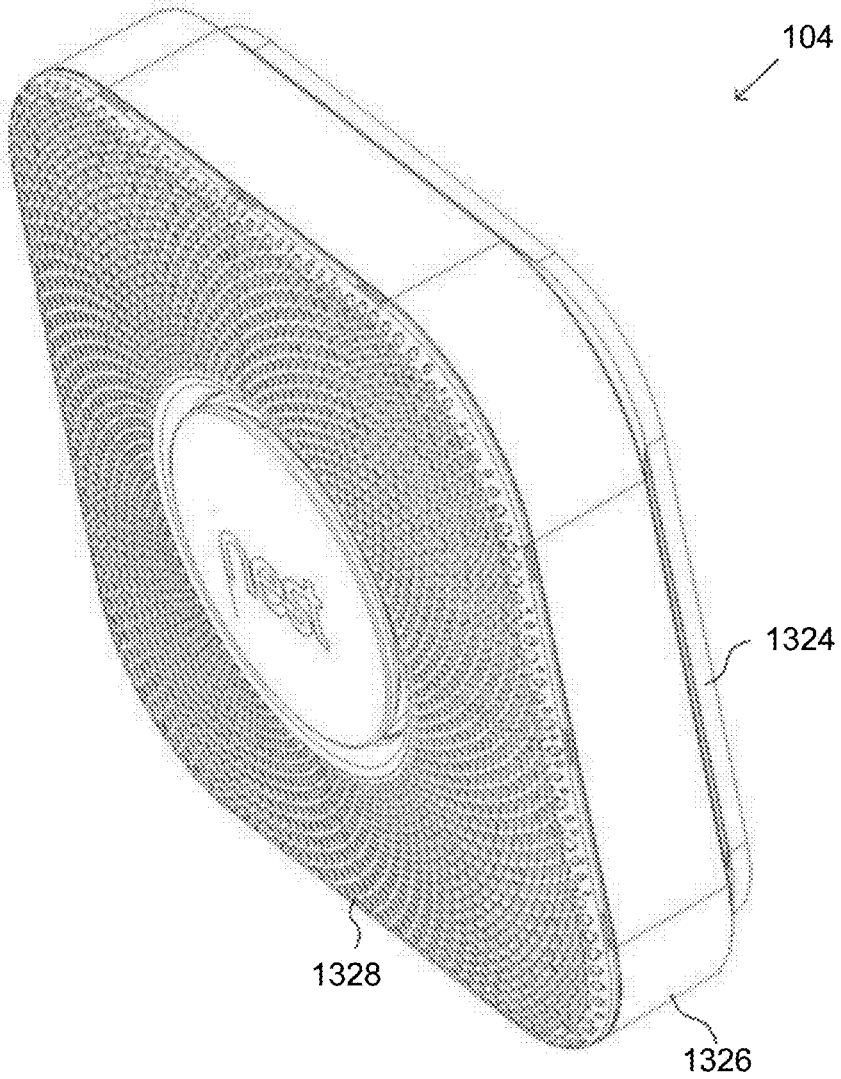


FIGURE 12C





**FIGURE 13A**

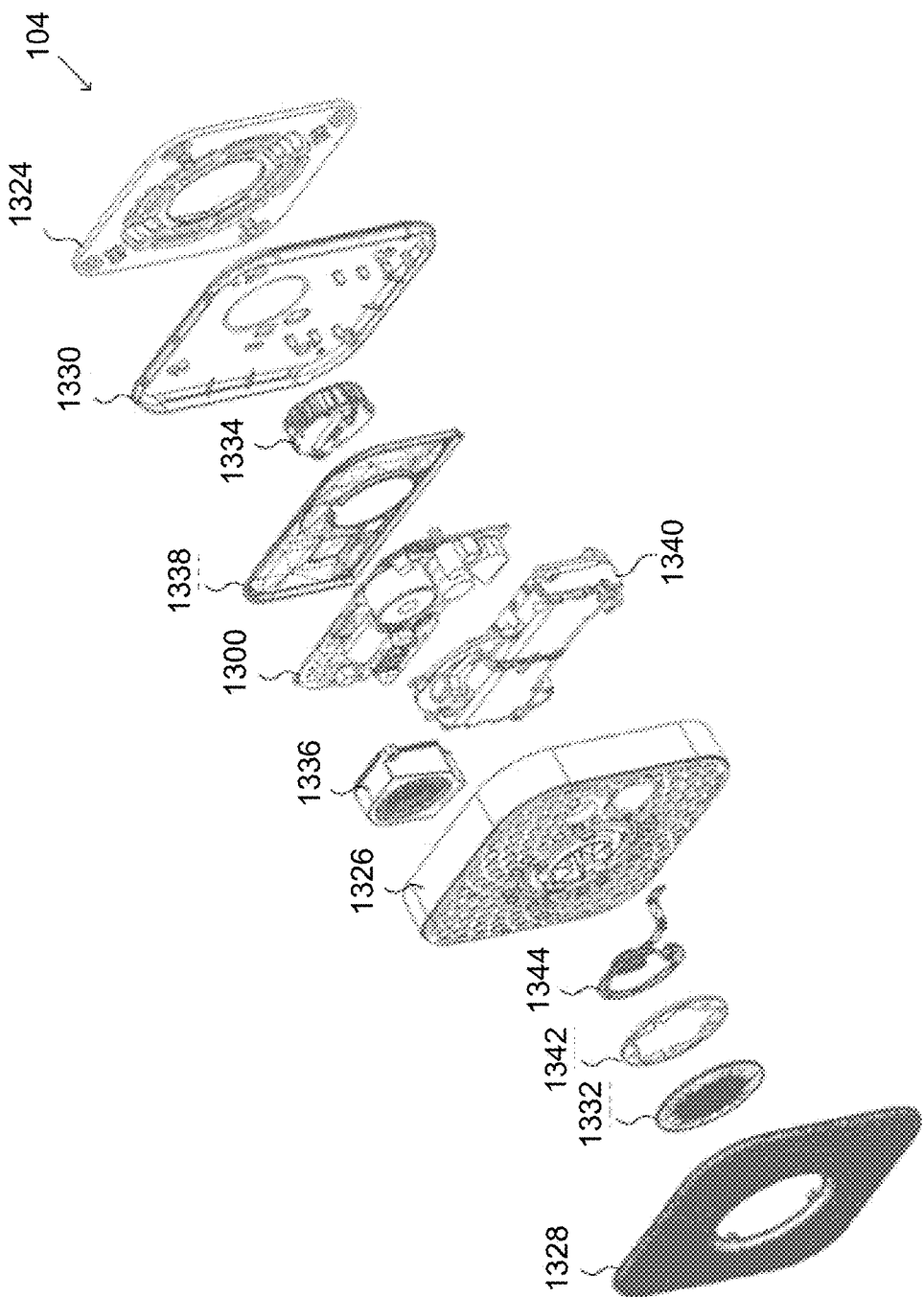


FIGURE 13B

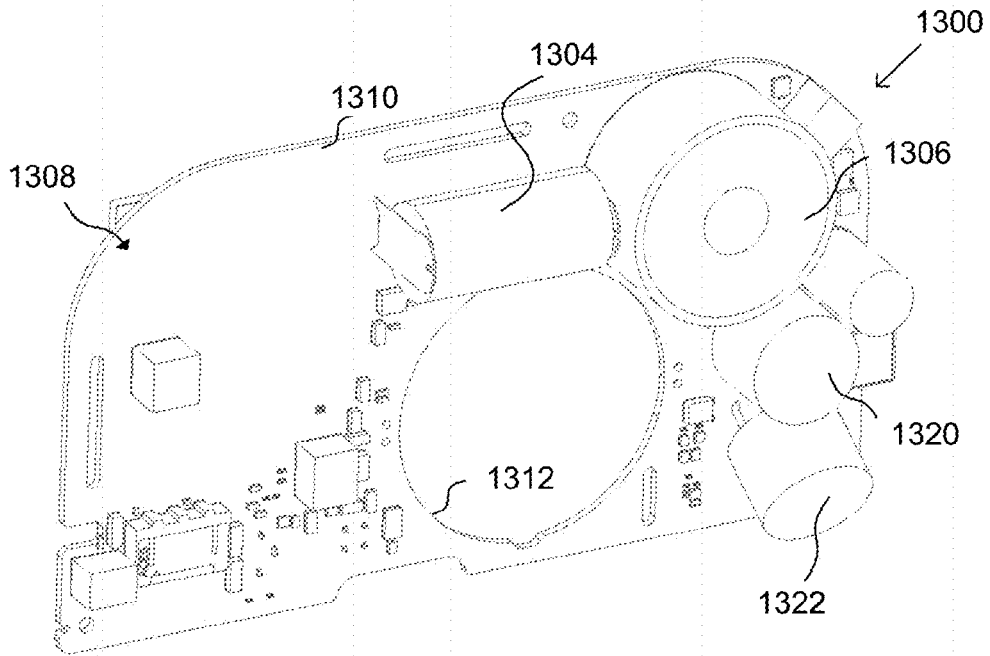


FIGURE 13C

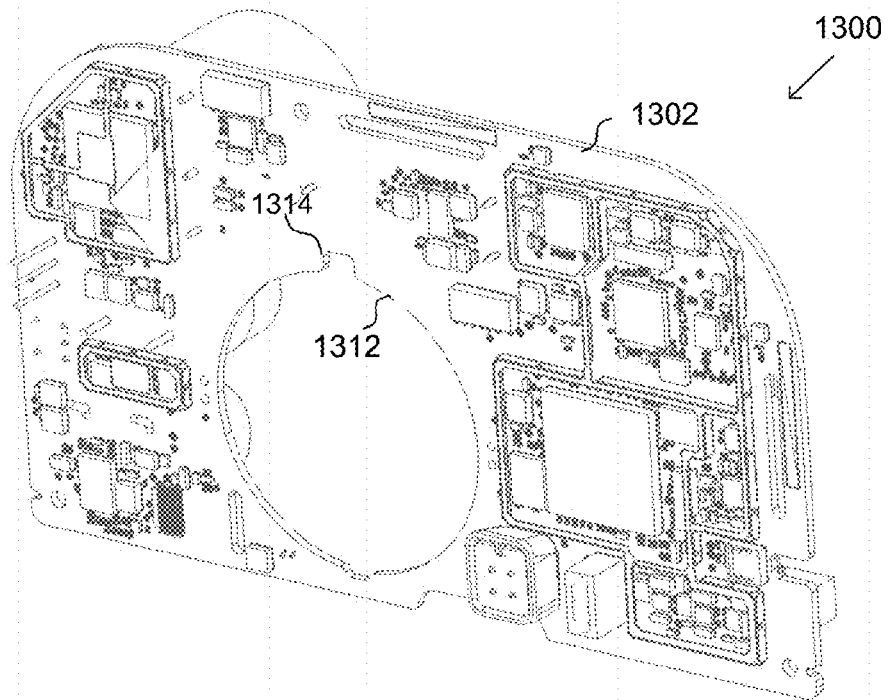


FIGURE 13D

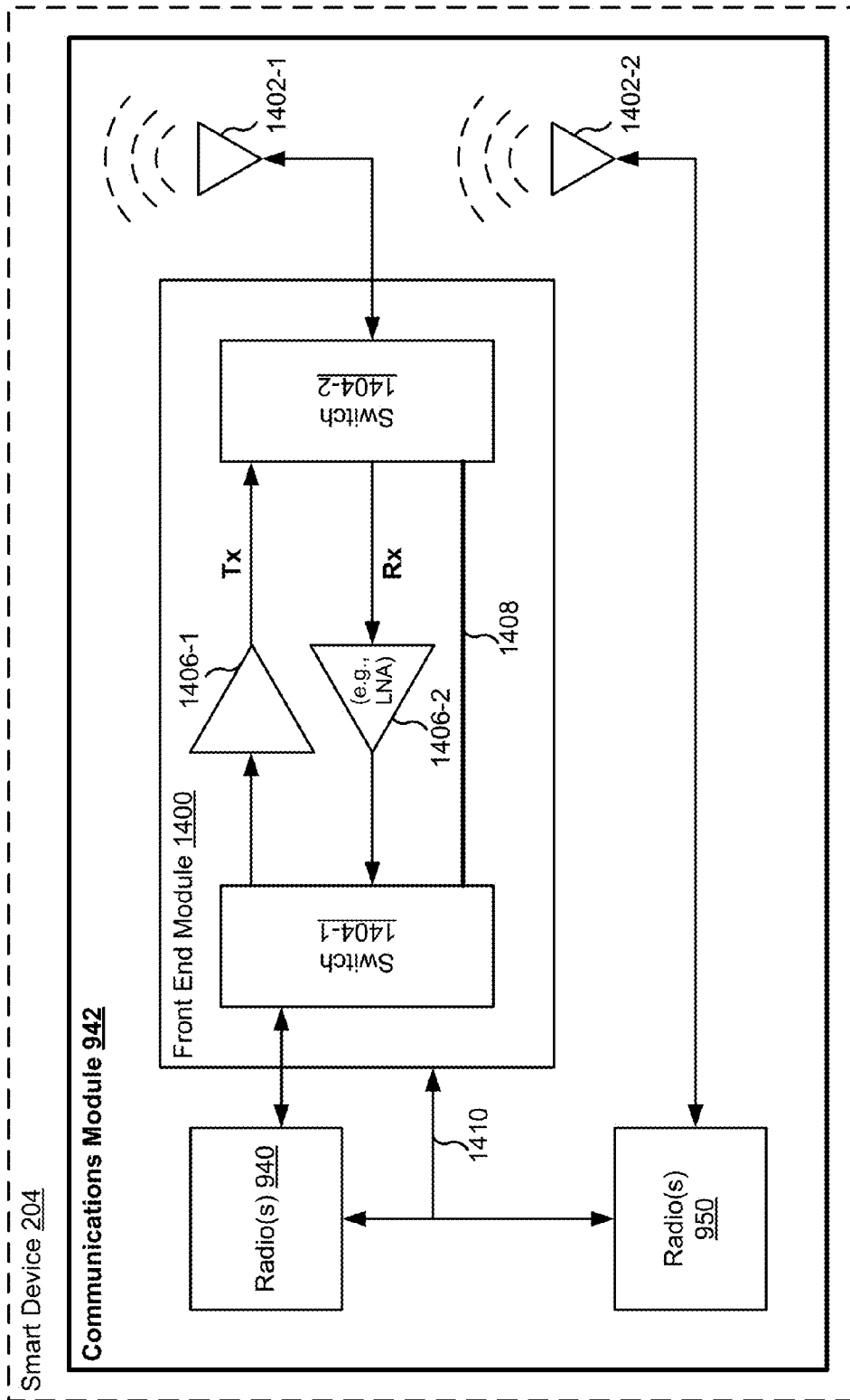


FIGURE 14

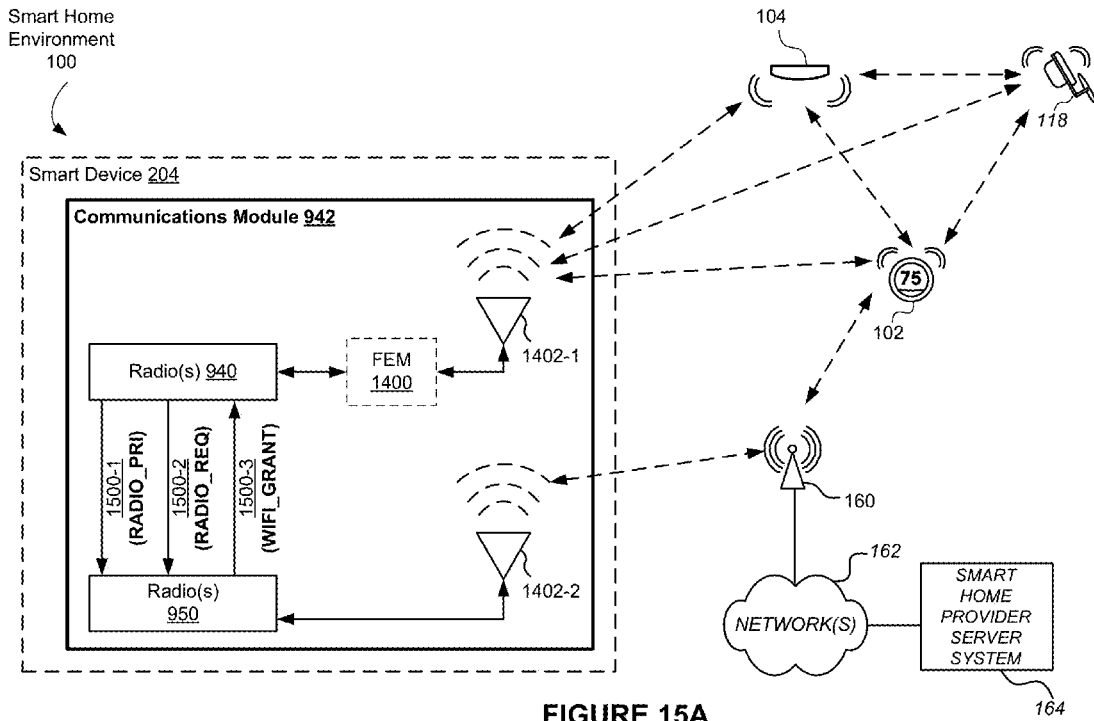


FIGURE 15A

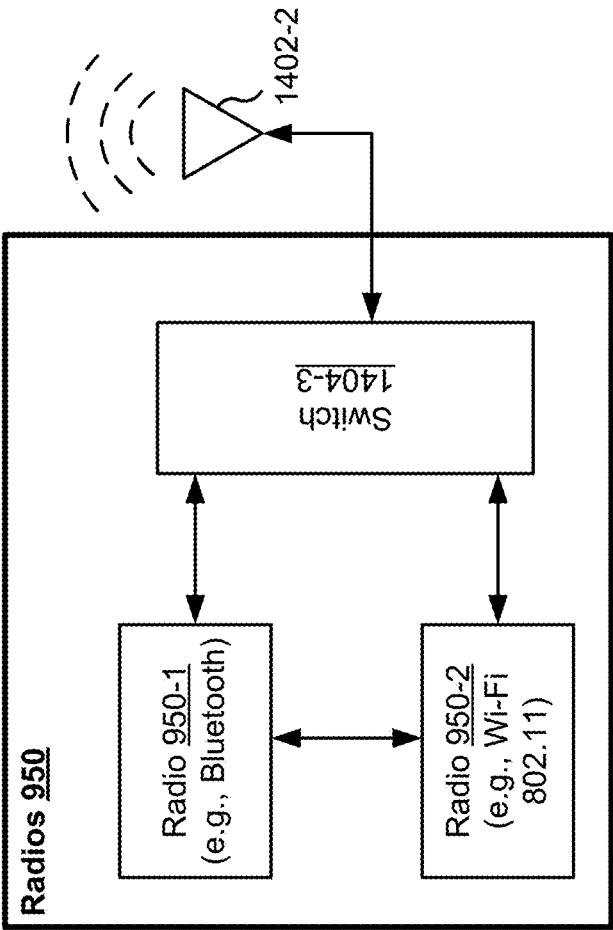


FIGURE 15B

Signal name	Description	Direction (from WIFI)	Assigned to WIFI pin
<b>RADIO_REQ</b>	802.15.4 radio is requesting access to the Wireless medium	Input	L6
<b>RADIO_PRI</b>	802.15.4 request priority.	Input	L7
<b>WIFL_GRANT</b>	WiFi radio is granting 802.15.4 radio access to the wireless medium	Output	L8

**FIGURE 15C**

Normal Mode

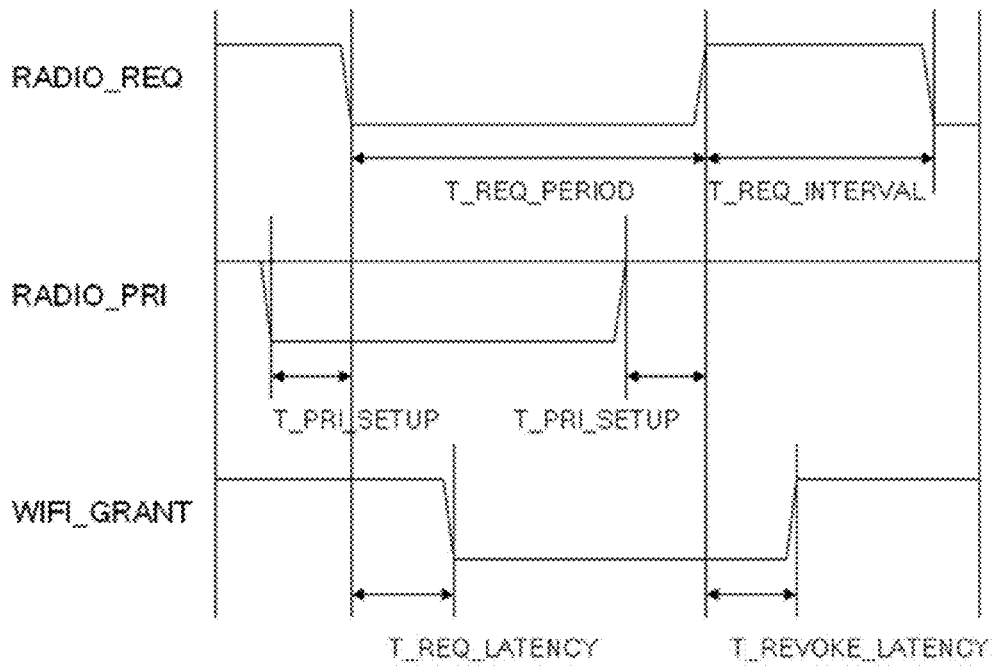


FIGURE 15D-1

Name	Description	min	max
T_REQ_PERIOD	Length of holding RADIO_REQ asserted.		
T_REQ_INTERVAL	Interval between RADIO_REQ	10ms	N/A
T_PRI_SETUP	Setup time to establish RADIO_PRI before asserting RADIO_REQ.	0	N/A
T_REQ_LATENCY	Latency between RADIO_REQ assert and WIFI_GRANT assert.	30us	
T_REVOKE_LATENCY	Latency between RADIO_REQ de-assert and WIFI_GRANT de-assert.	30us	3.5ms

FIGURE 15D-2



High Priority Wi-Fi (i.e., Grant Revoke)

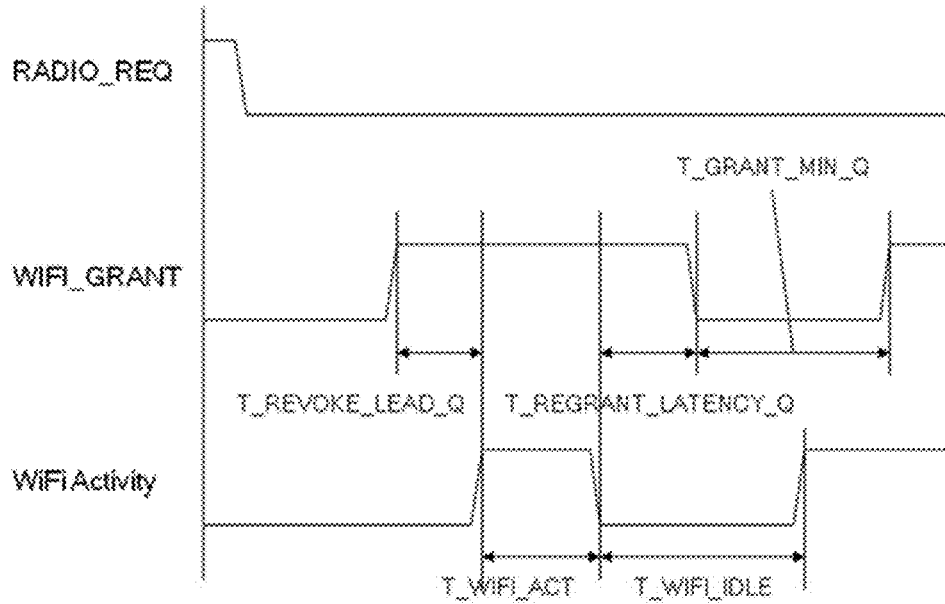


FIGURE 15E-1

Name	Description	min	max
T_REVOKE_LEAD_Q	Lead period between WIFI_GRANT is de-asserted and WiFi transmission.	200ns	N/A
T_REGRANT_LATENCY_Q	Latency between WiFi transmission is done and WIFI_GRAIT is re-asserted.	0	N/A
T_GRANT_MIN_Q	Minimum period which WIFI_GRANT can be guaranteed to be asserted.	0	N/A
T_WIFLACT	Period for high-priority WiFi transmission.	400us	N/A
T_WIFLIDLE	Interval between high-priority WiFi transmission request	0	N/A

FIGURE 15E-2

Beacon Protection

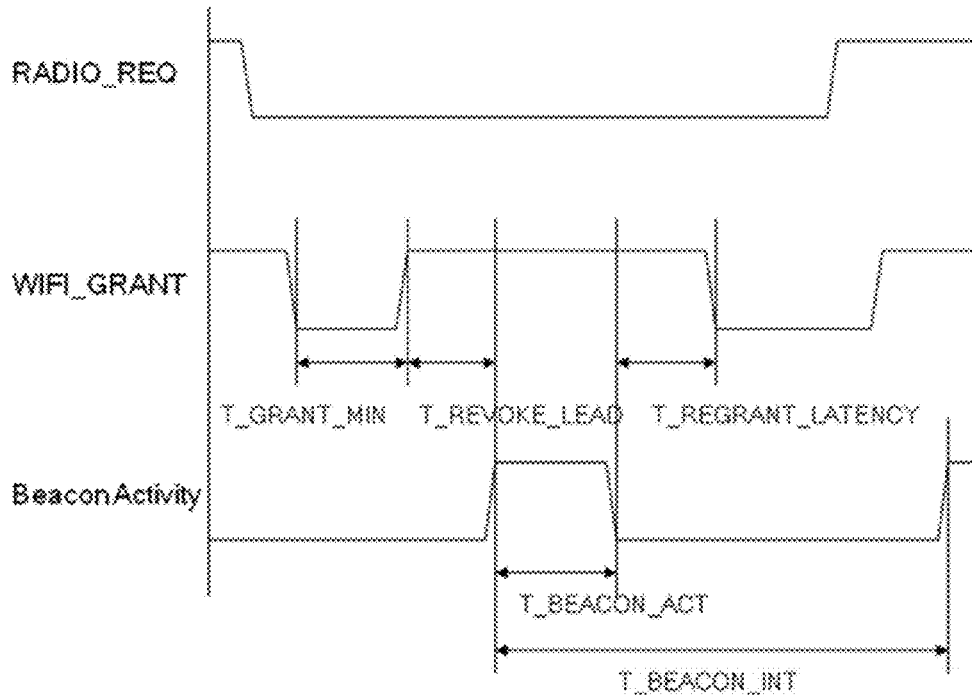


FIGURE 15F-1

Name	Description	min	max
T_GRANT_MIN	Minimum period which WIFI_GRANT can be guaranteed to be asserted before revoked by beacon.		N/A
T_REVOKE_LEAD	Lead period between WIFI_GRANT is deasserted and WiFi beacon is scheduled to be received.		N/A
T_REGRANT_LATENCY	Latency between WiFi beacon is received (or missed) and WIFI_GRAIT is re-asserted.	0	N/A
T_BEACON_ACT	Period between WiFi beacon is received or missed.	N/A	
T_BEACON_INT	WiFi beacon interval		N/A

FIGURE 15F-2

Beacon Skipping

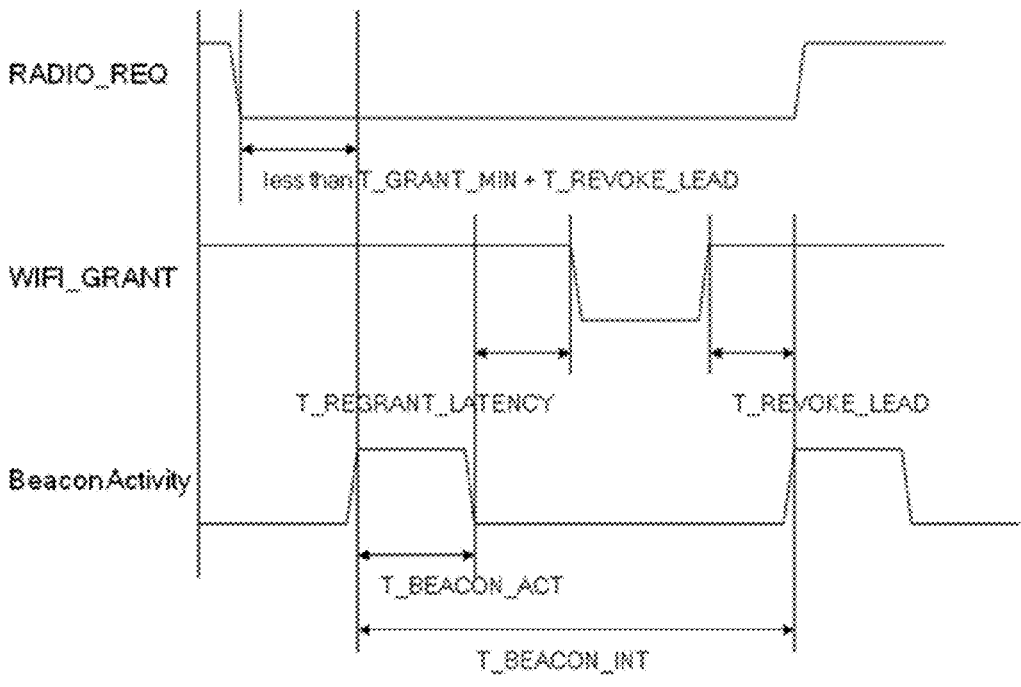


FIGURE 15F-3

Alarming Mode

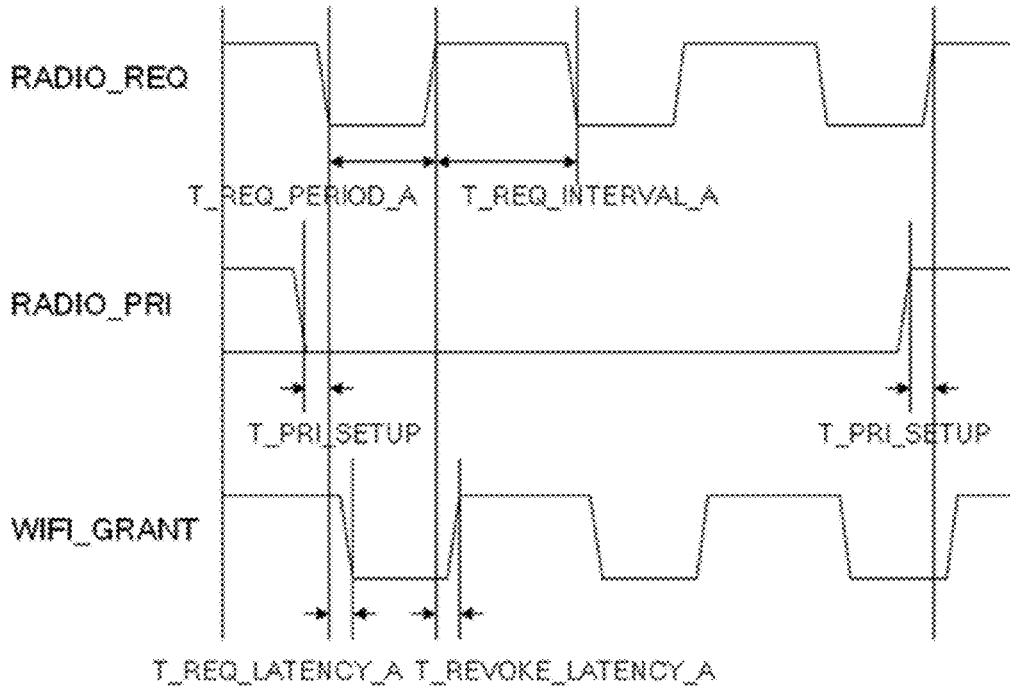


FIGURE 15G-1

Name	Description	min	max
T_REQ_PERIOD_A	Duration to hold RADIO_REQ in alert mode.	900us	N/A
T_REQ_INTEVAL_A	Interval between RADIO_REQ in alert mode.	3100us	N/A
T_REQ_LATENCY_A	Latency between RADIO_REQ assert and WIFL_GRANT assert in alert mode.	30us	5ms (*2)
T_REVOKE_LATENCY_A	Latency between RADIO_REQ de-assert and WIFL_GRANT de-assert in alert mode.	30us	5ms (*2)

FIGURE 15G-2

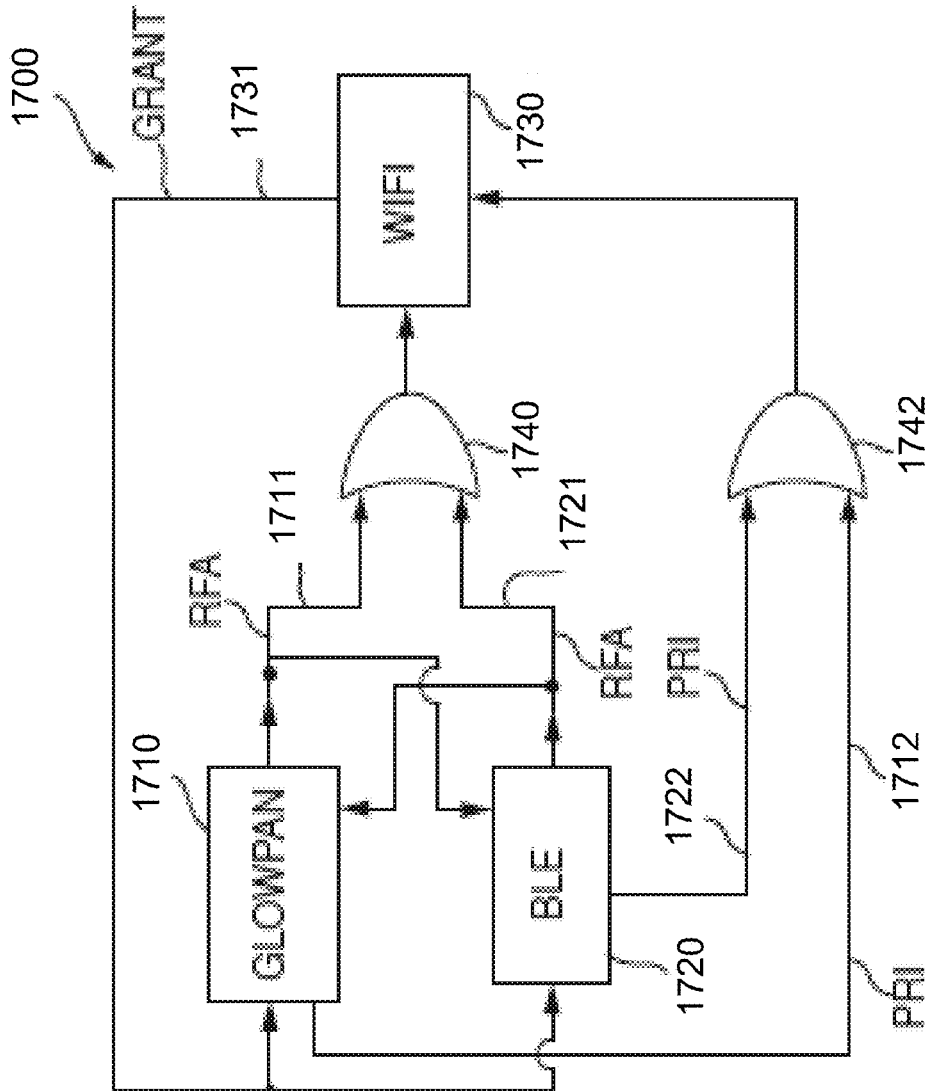


FIGURE 16

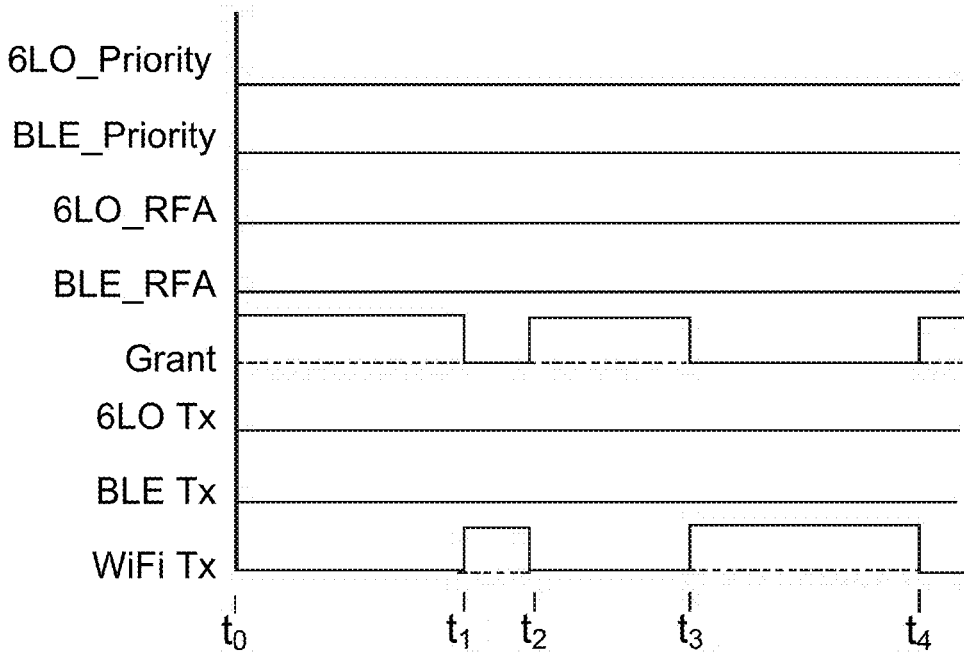


FIGURE 17A

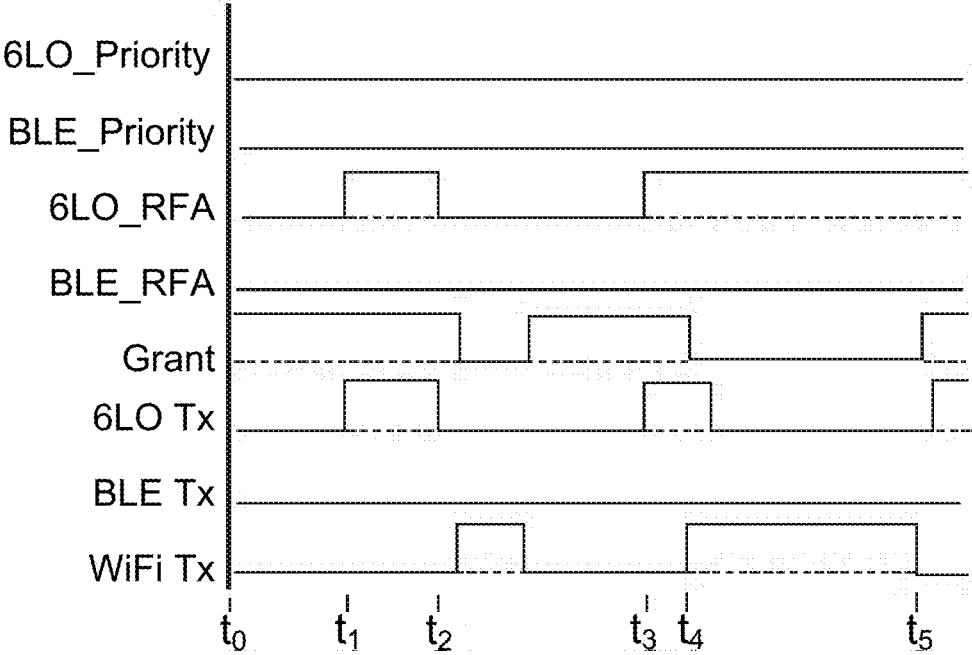


FIGURE 17B

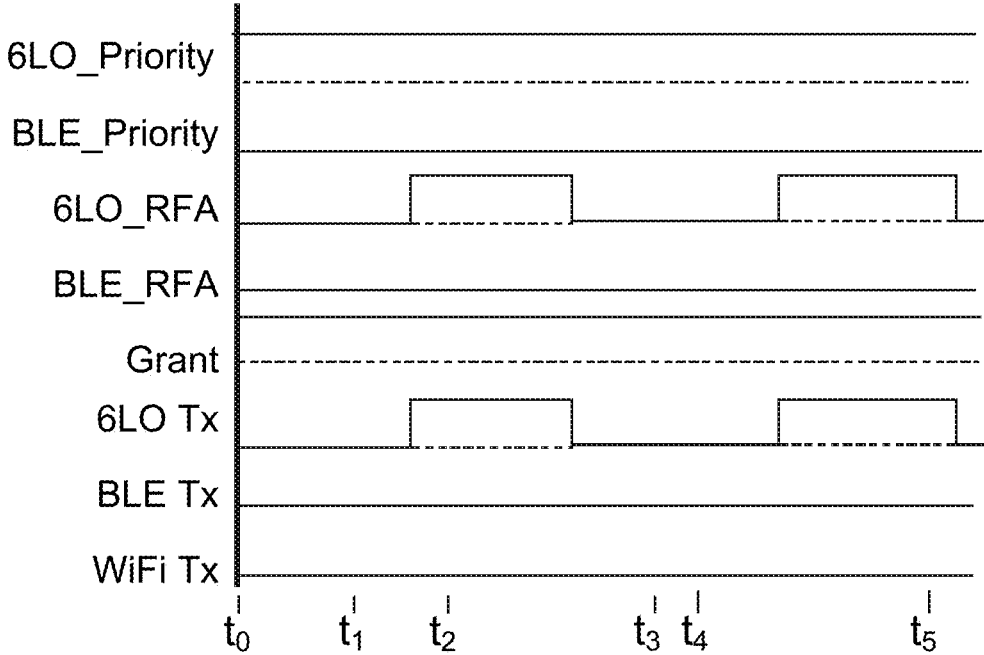
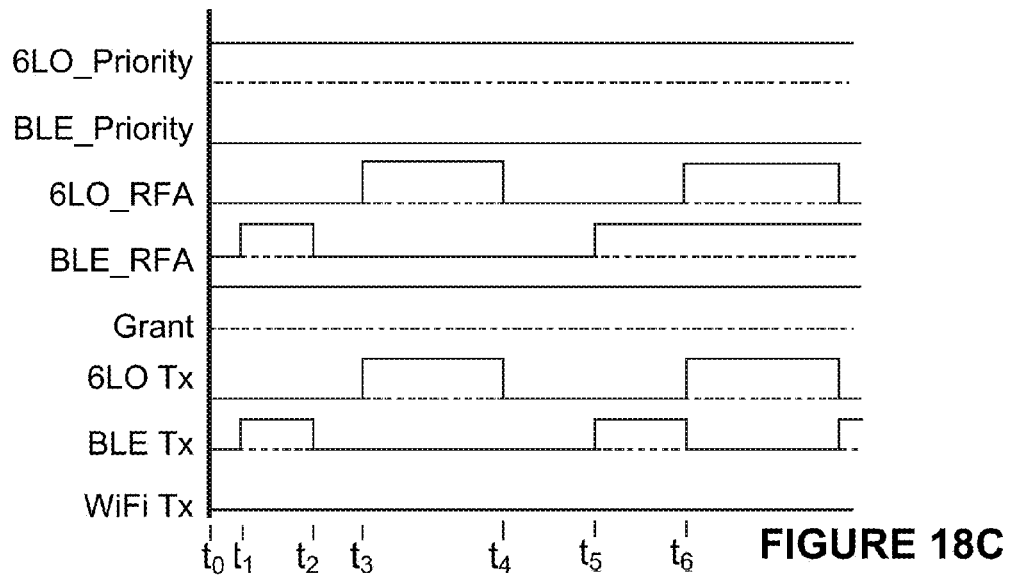
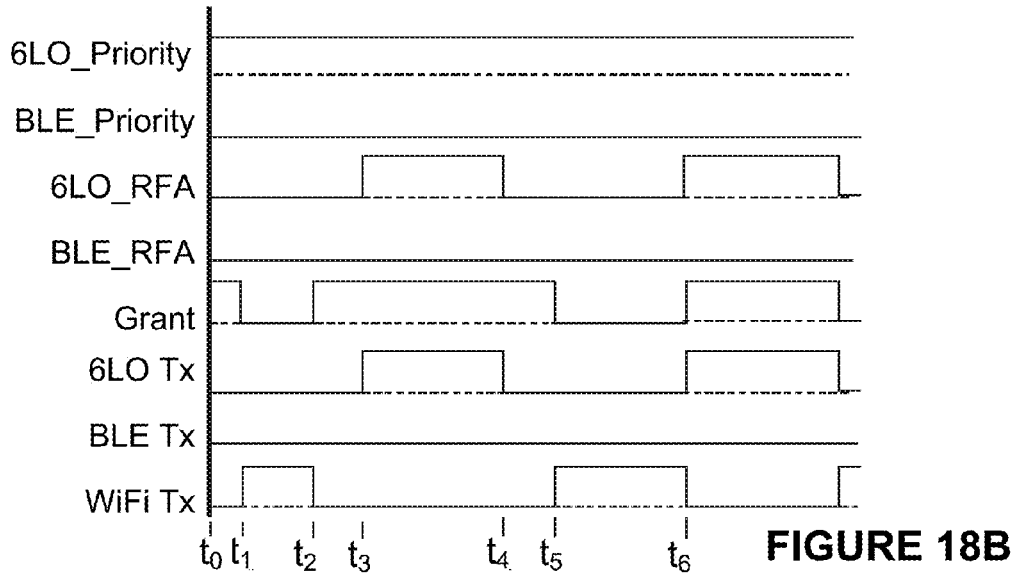


FIGURE 18A





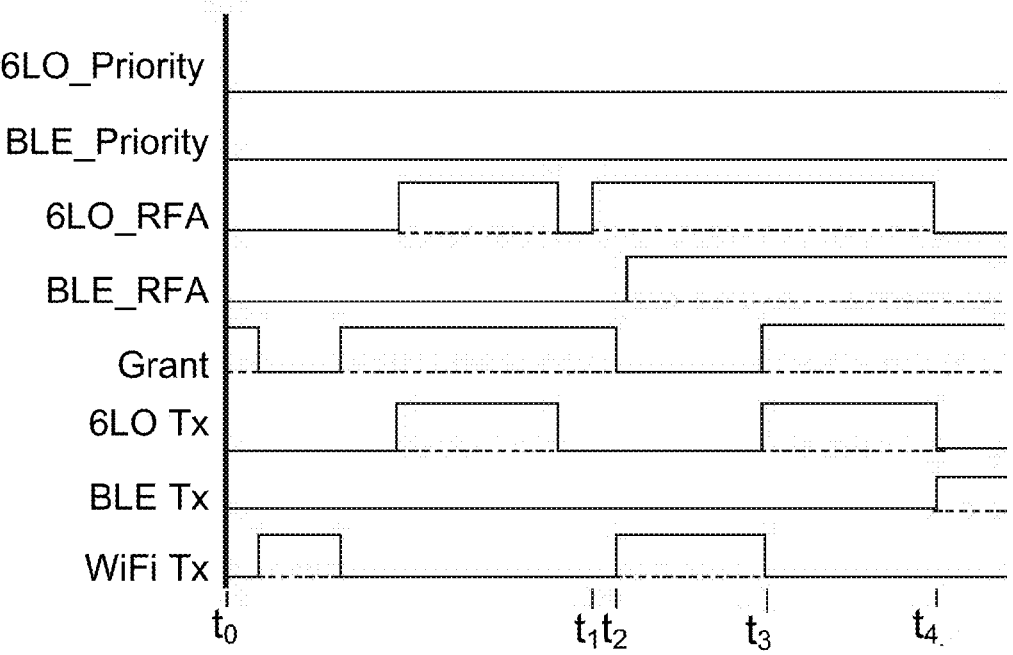
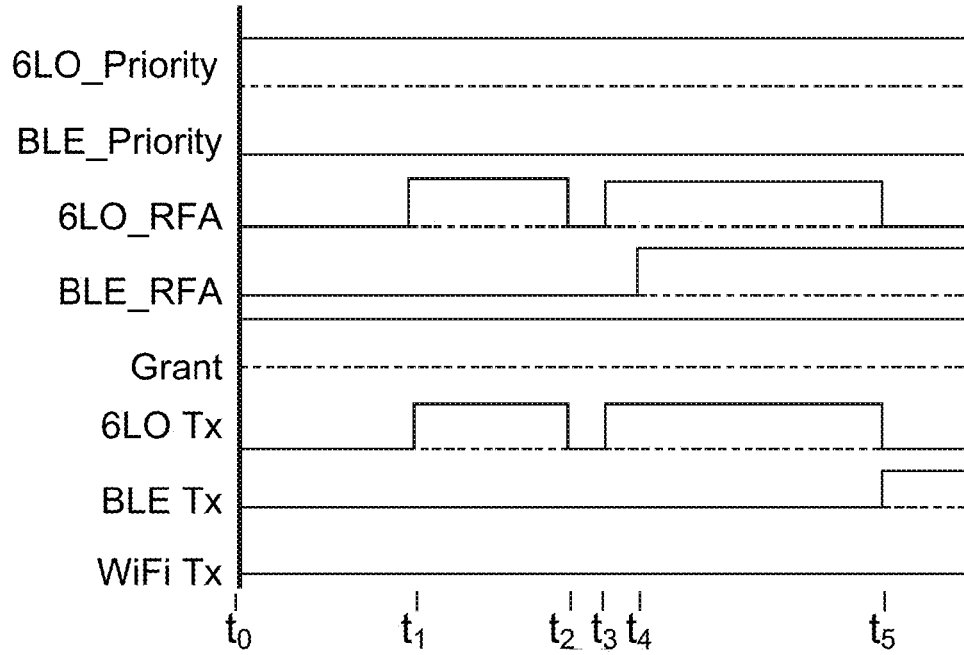
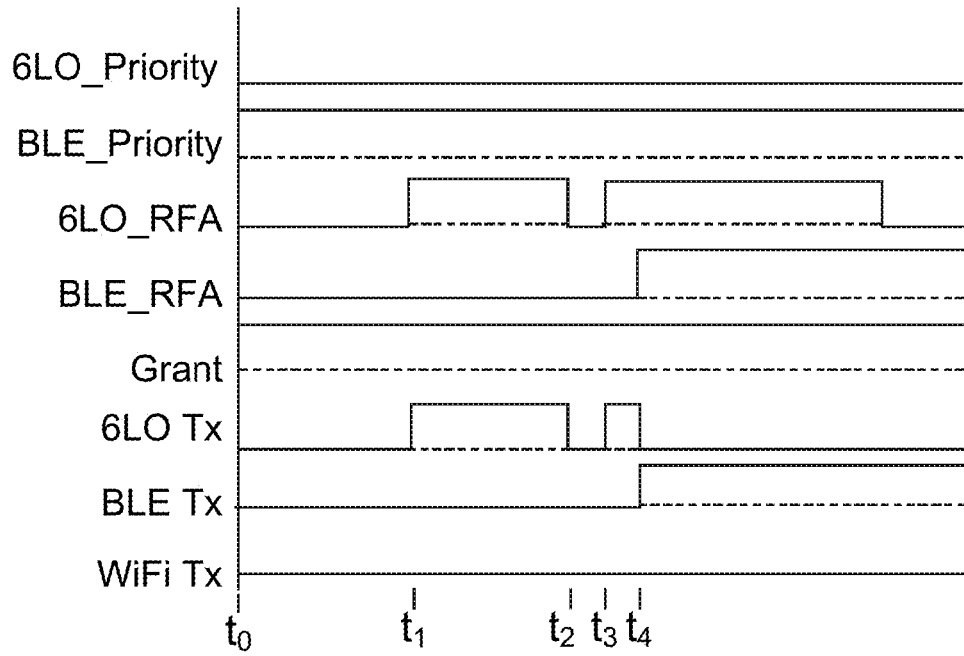


FIGURE 18D



**FIGURE 19A**



**FIGURE 19B**

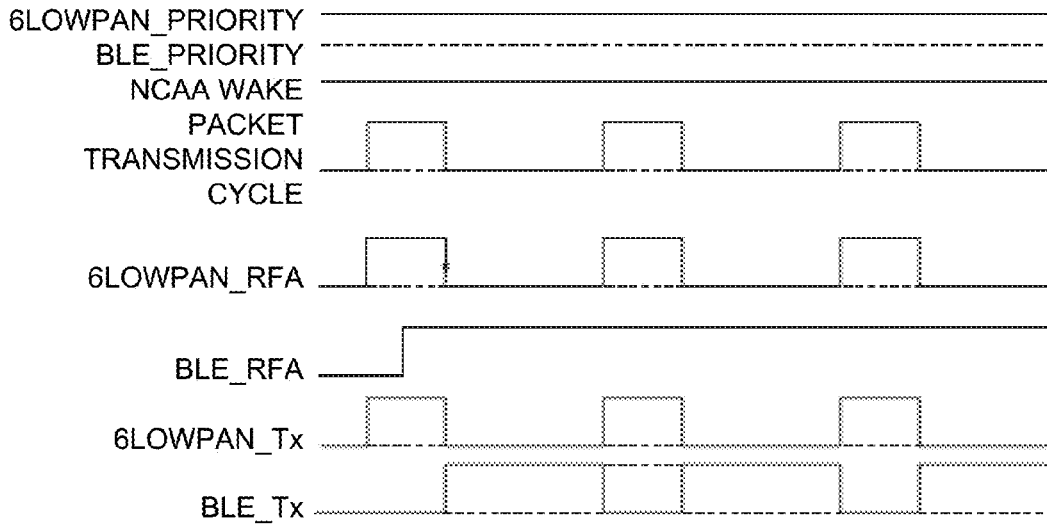


FIGURE 20

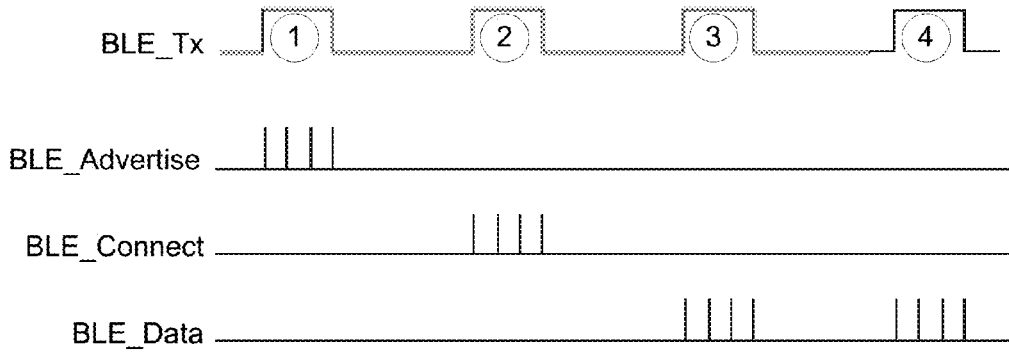
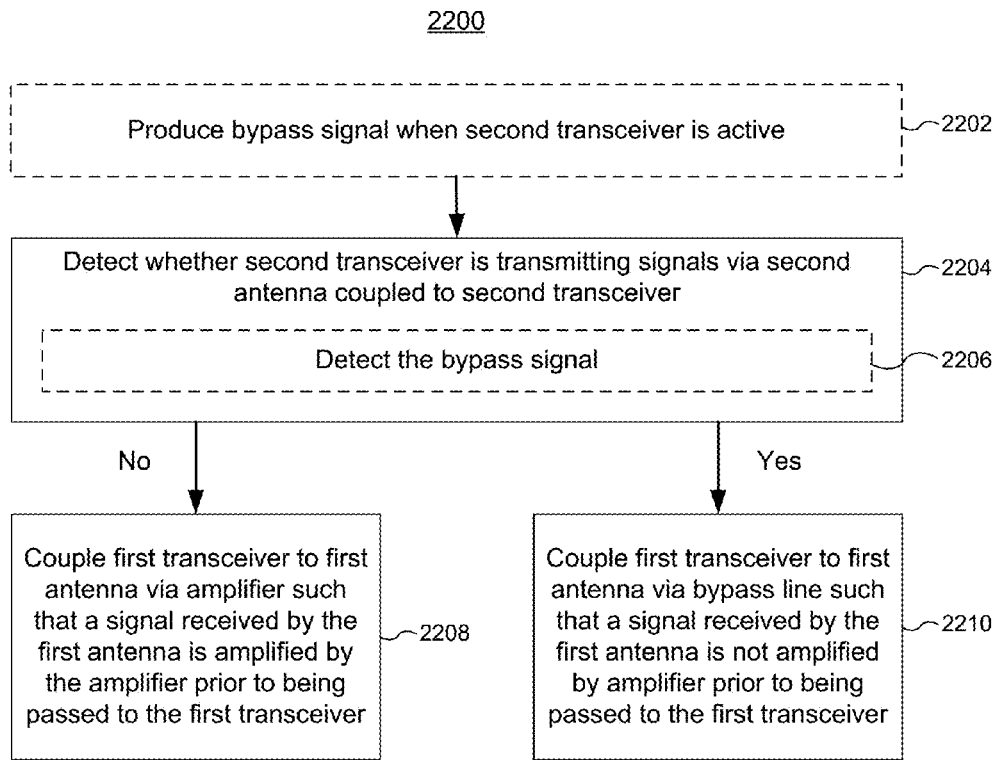


FIGURE 21



**FIGURE 22**

2300

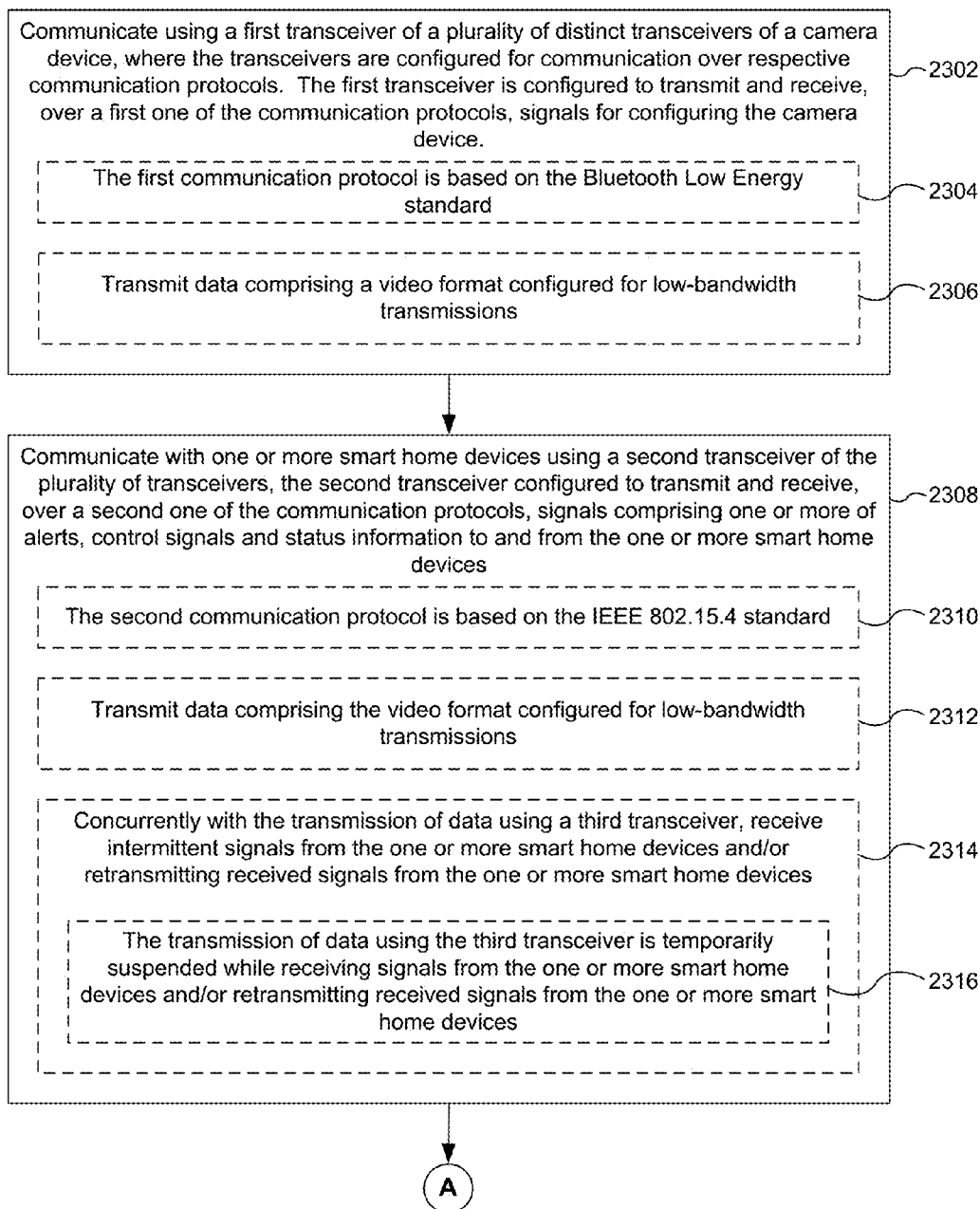


FIGURE 23A

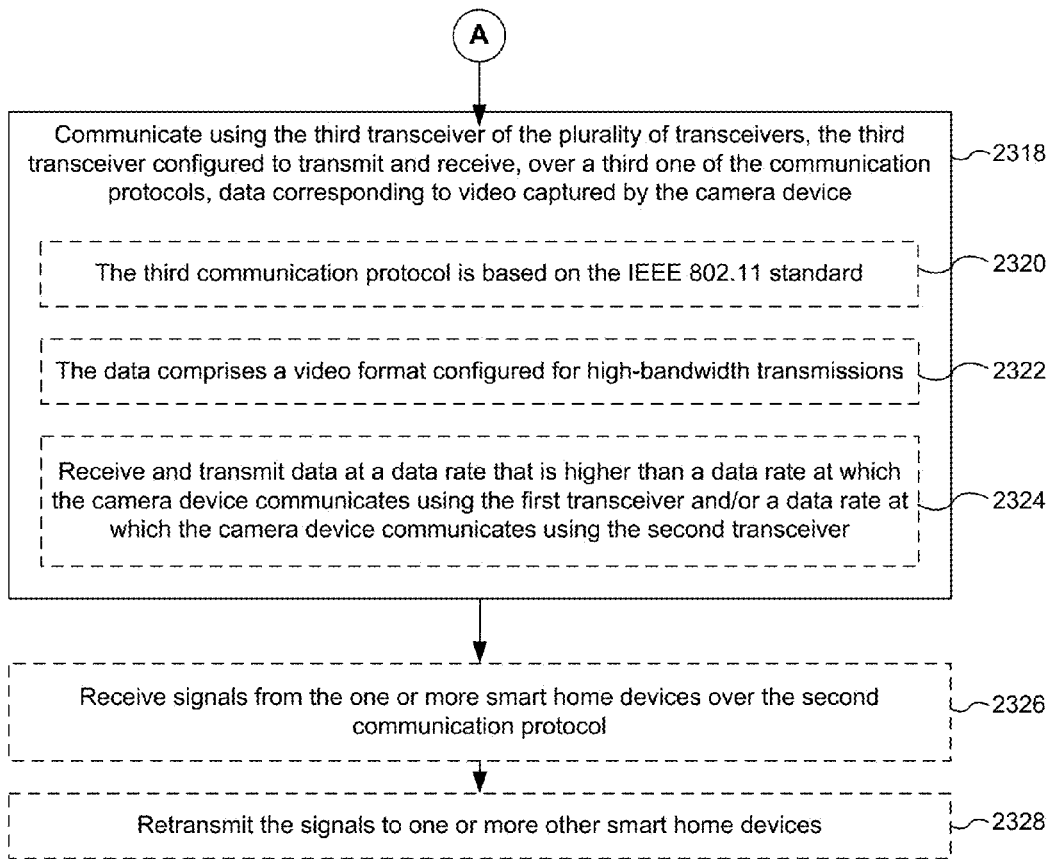
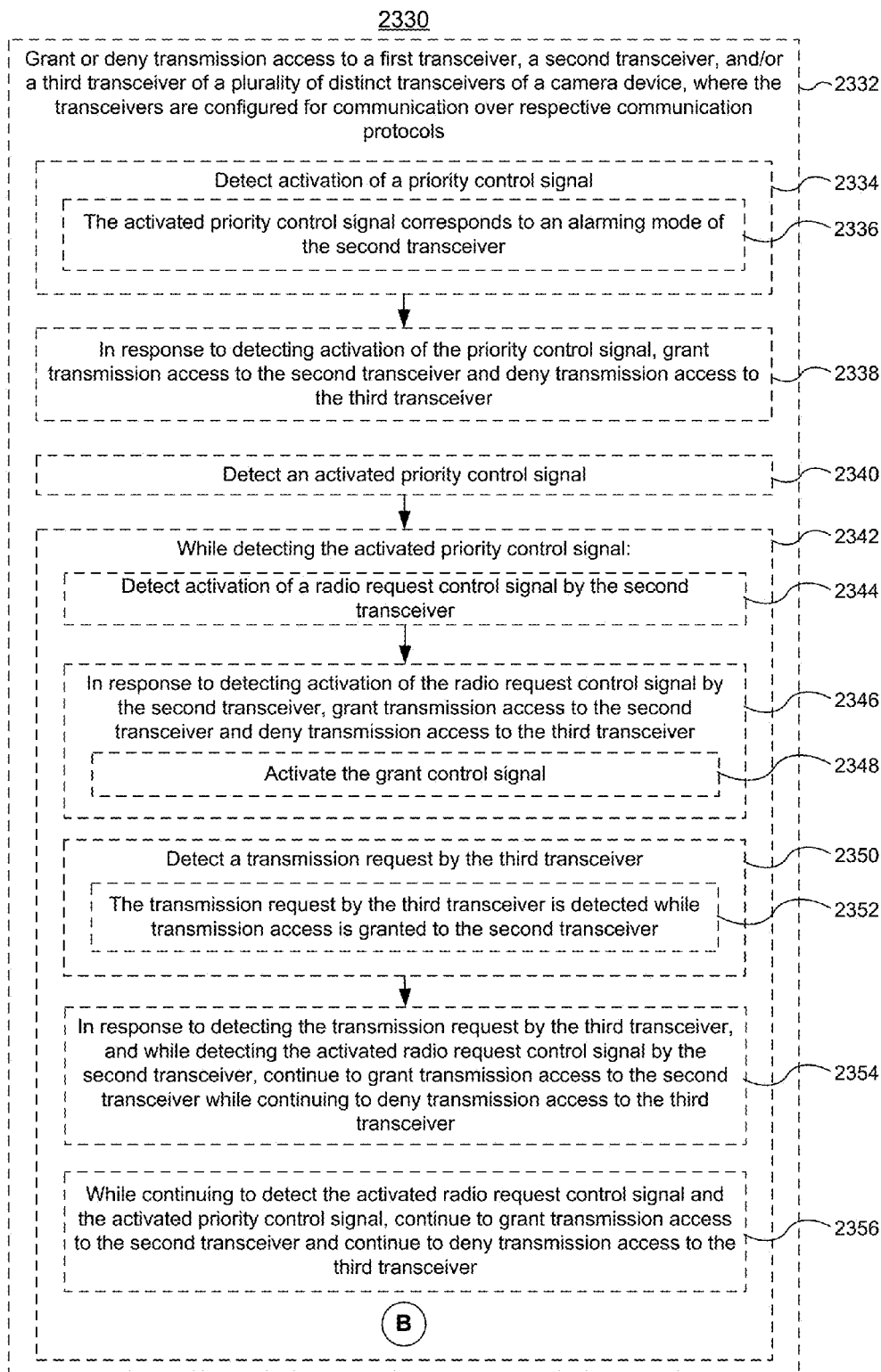


FIGURE 23B



**FIGURE 23C**



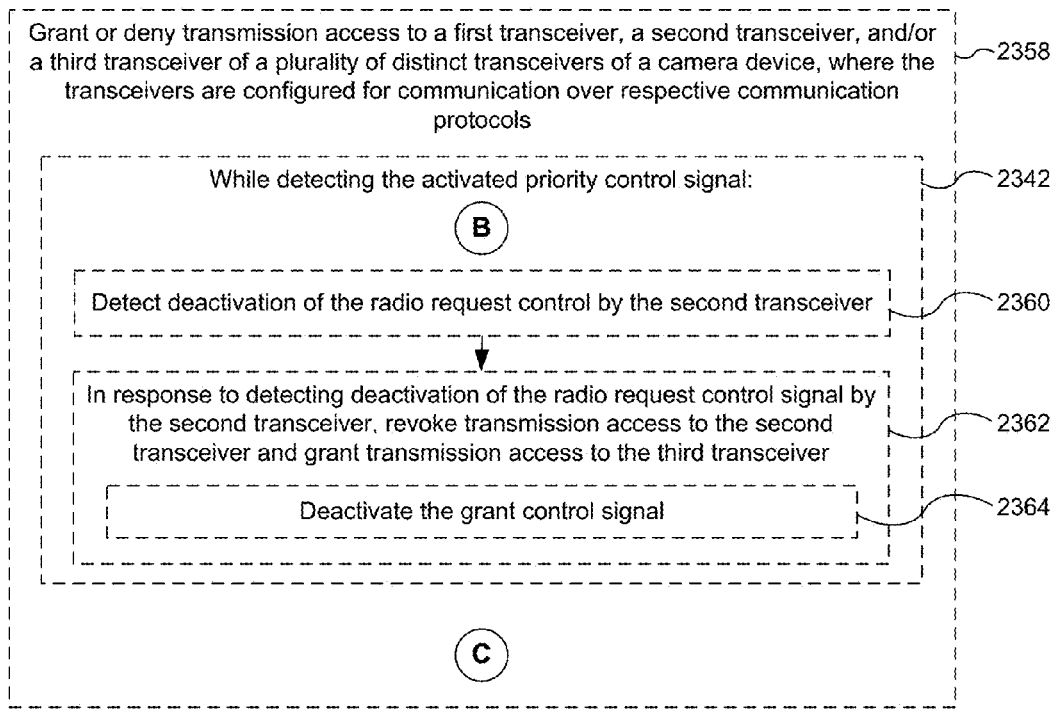


FIGURE 23D

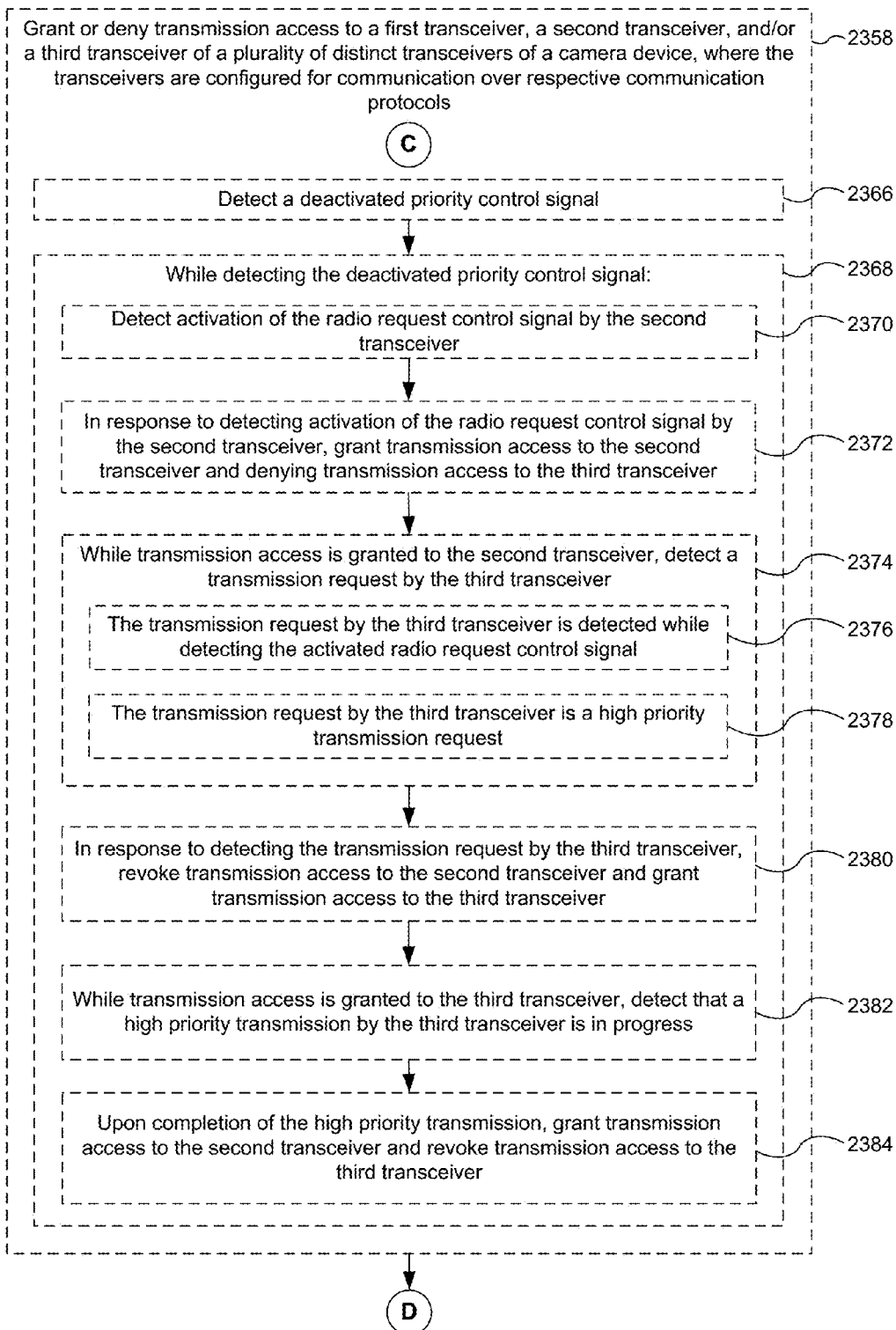


FIGURE 23E

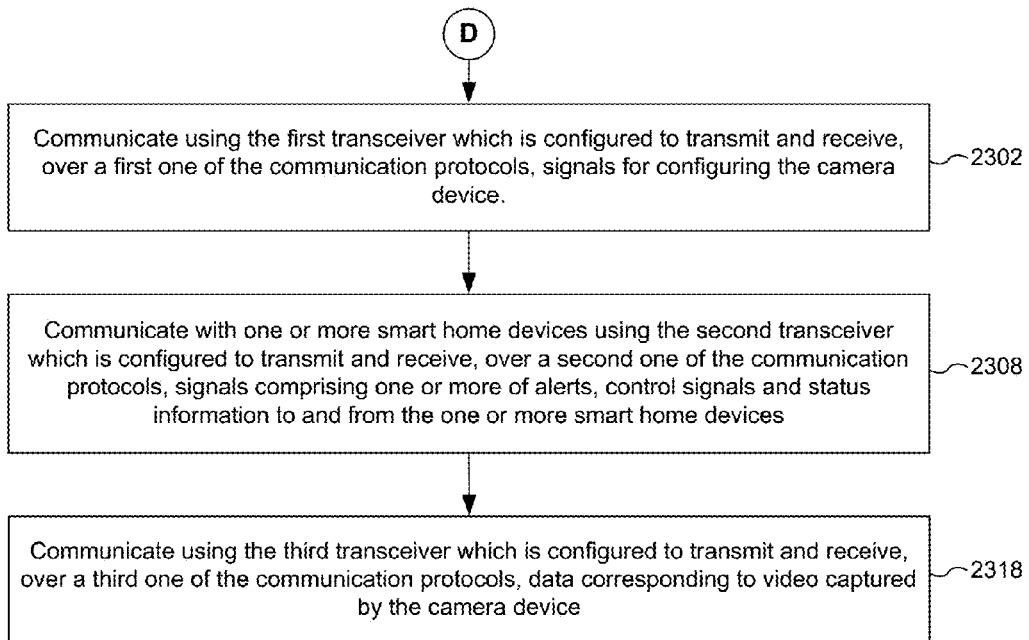


FIGURE 23F

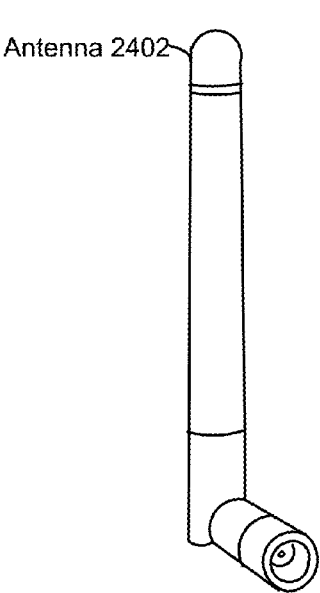


FIG. 24A

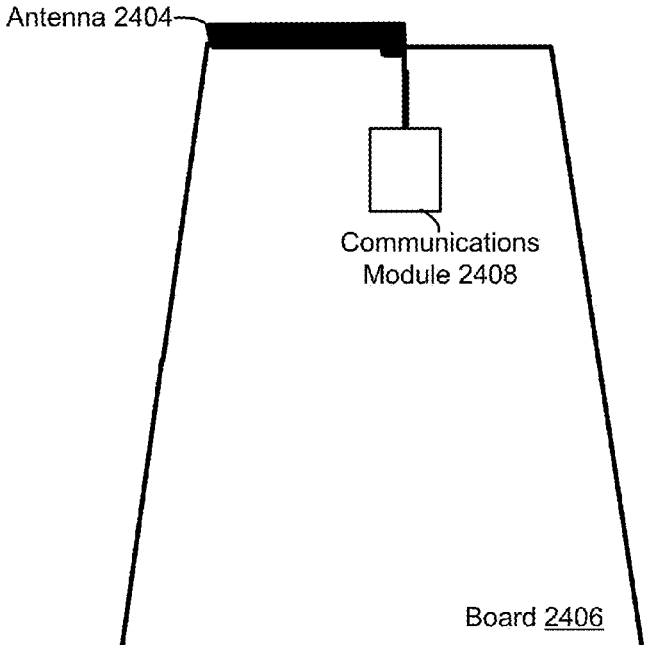


FIG. 24B

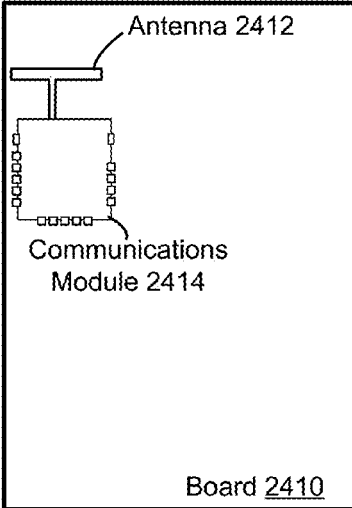


FIG. 24C

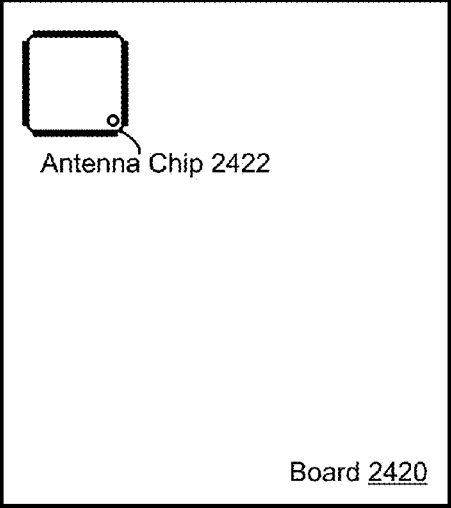


FIG. 24D

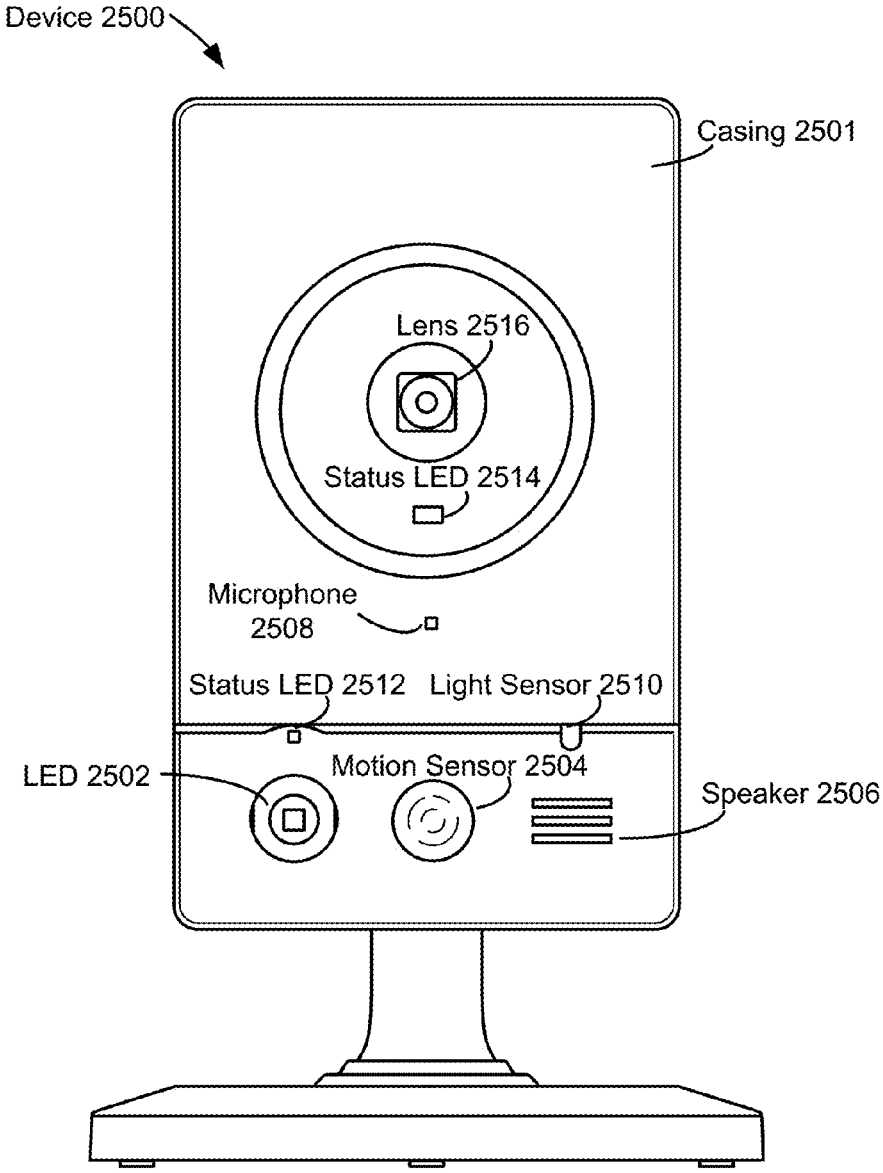


FIG. 25A

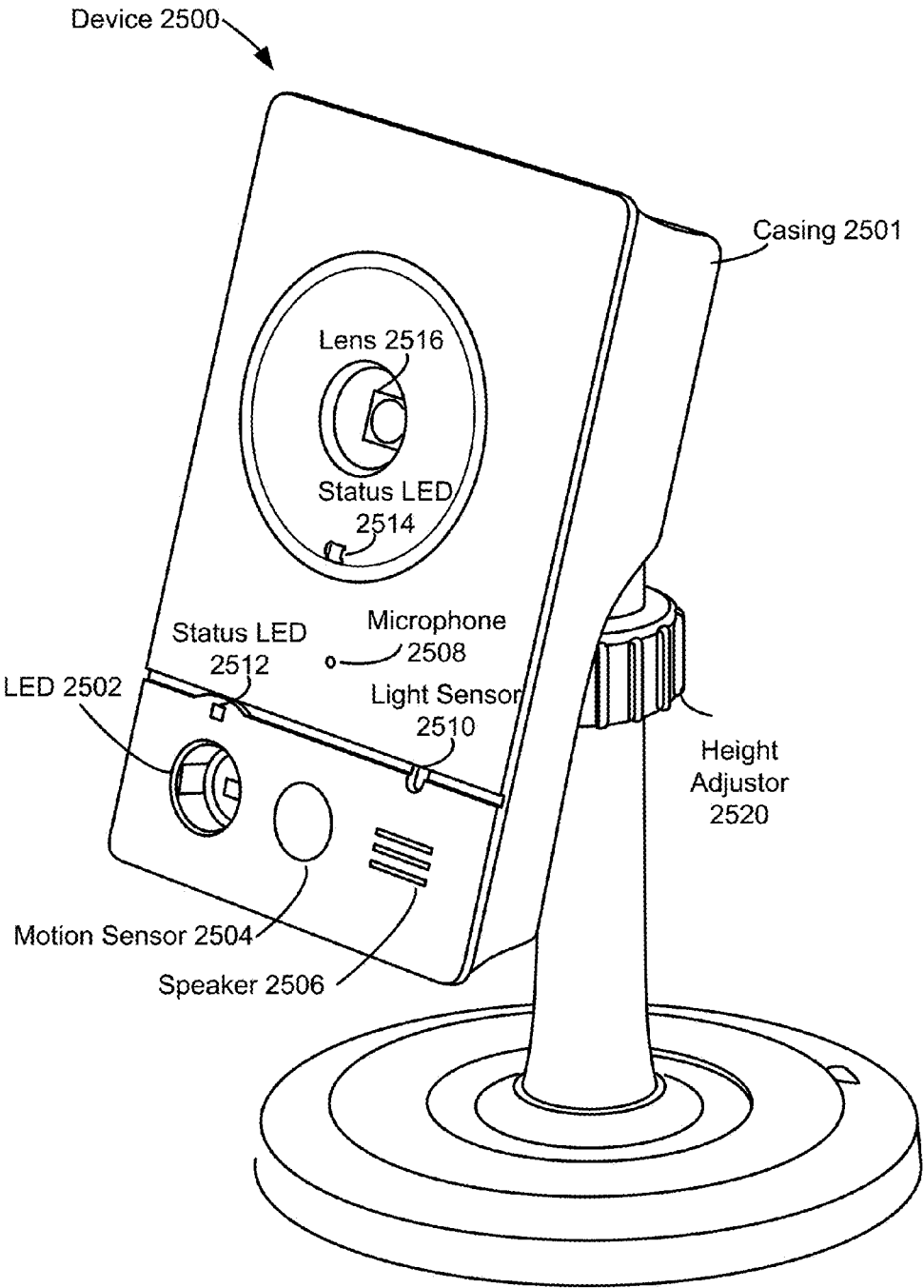


FIG. 25B

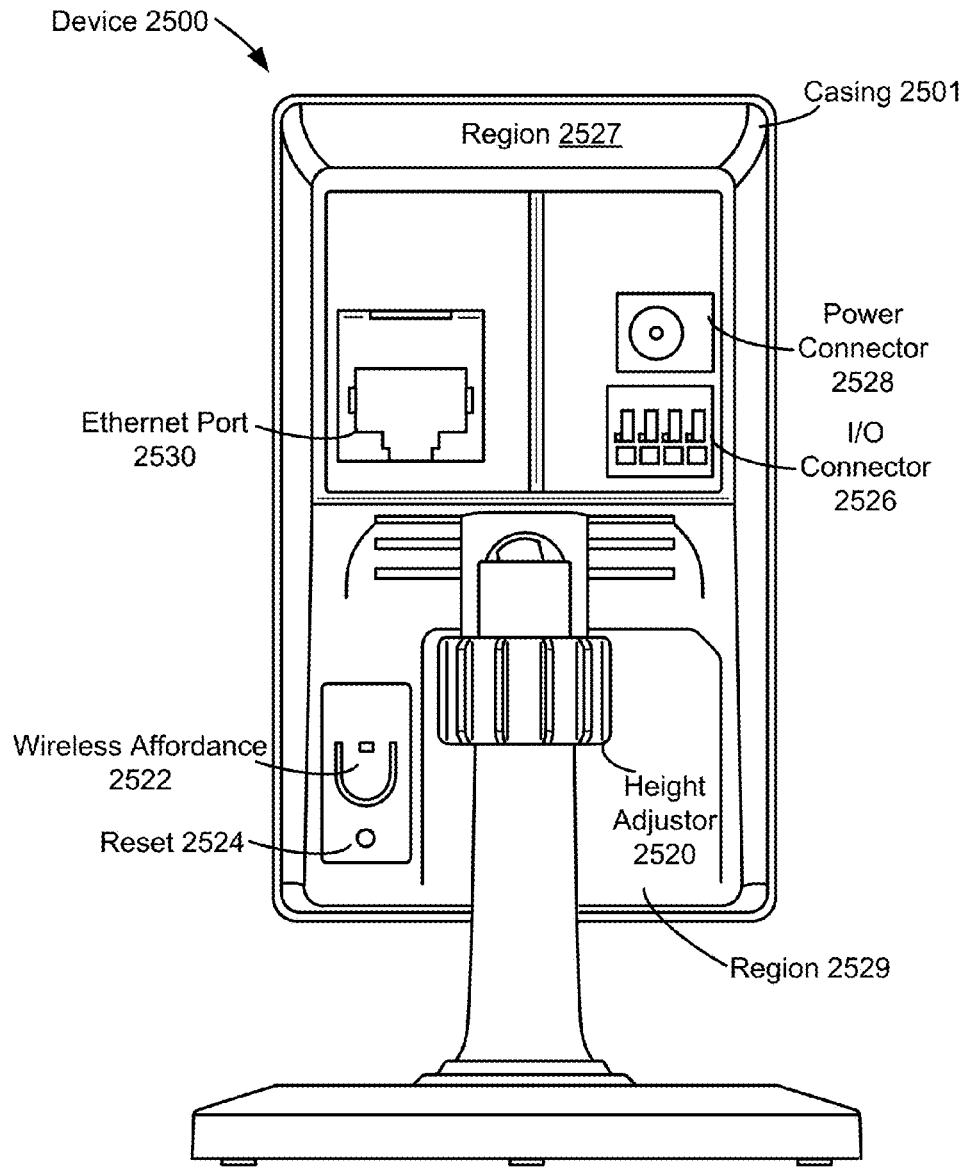


FIG. 25C

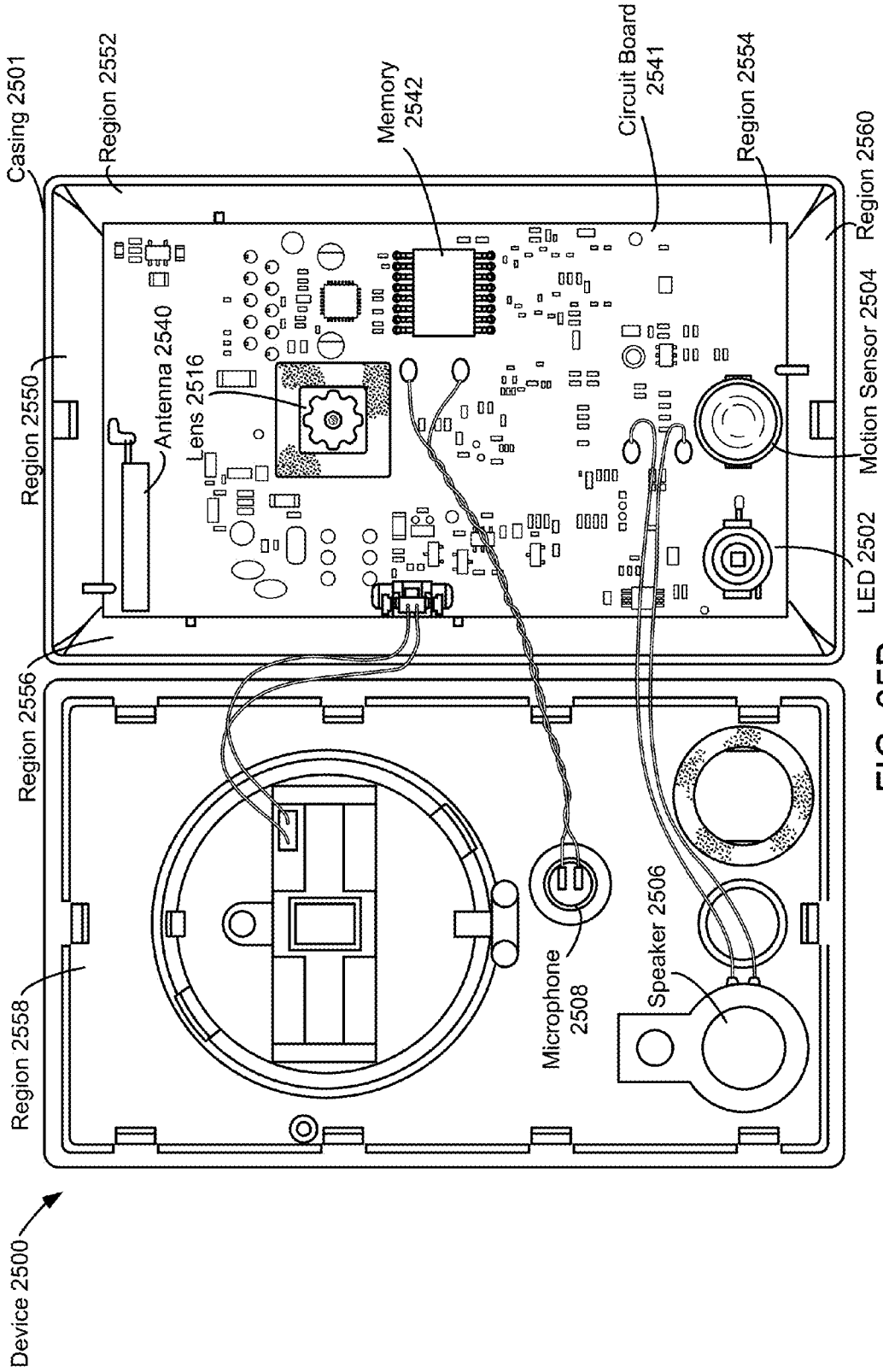


FIG. 25D



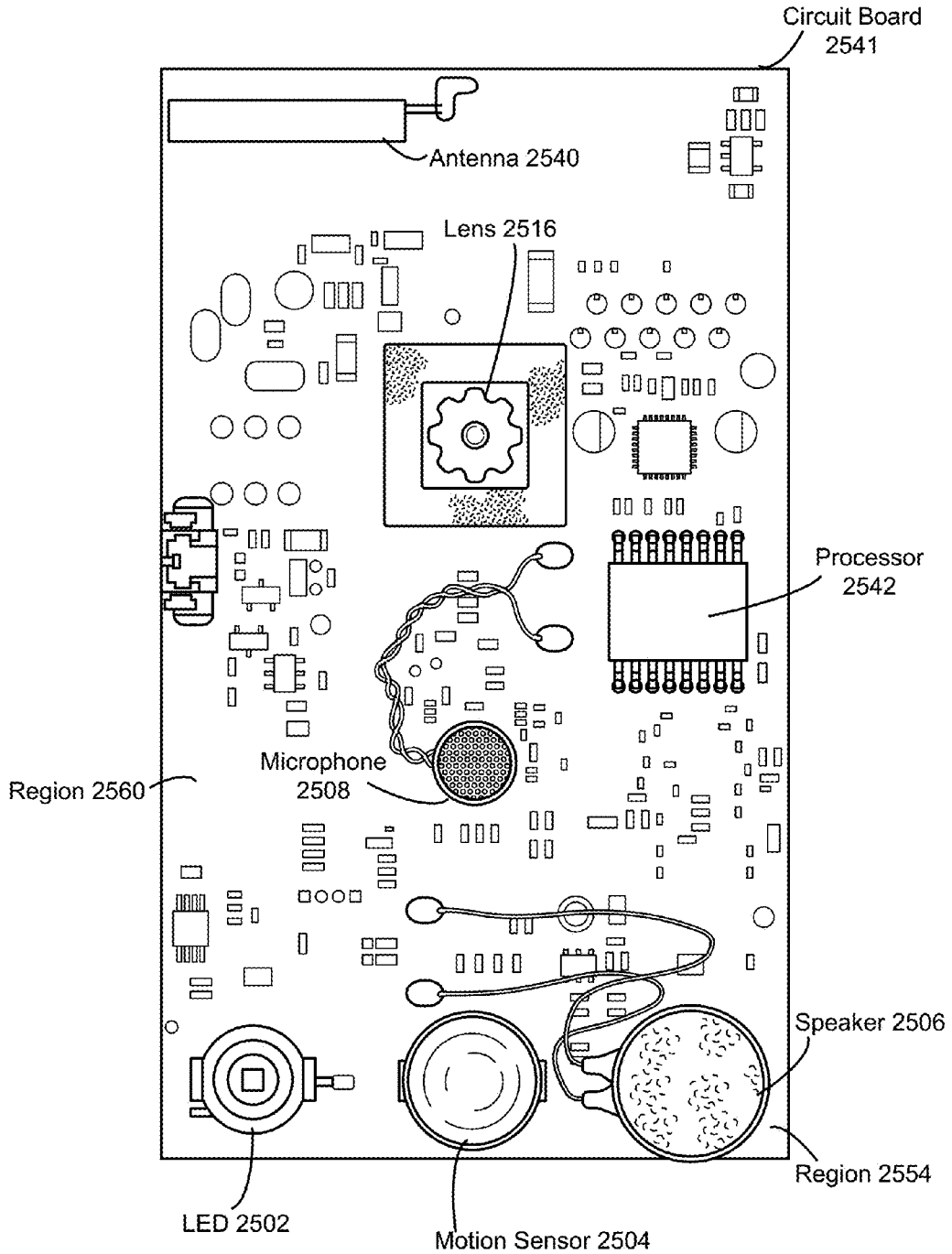


FIG. 25E

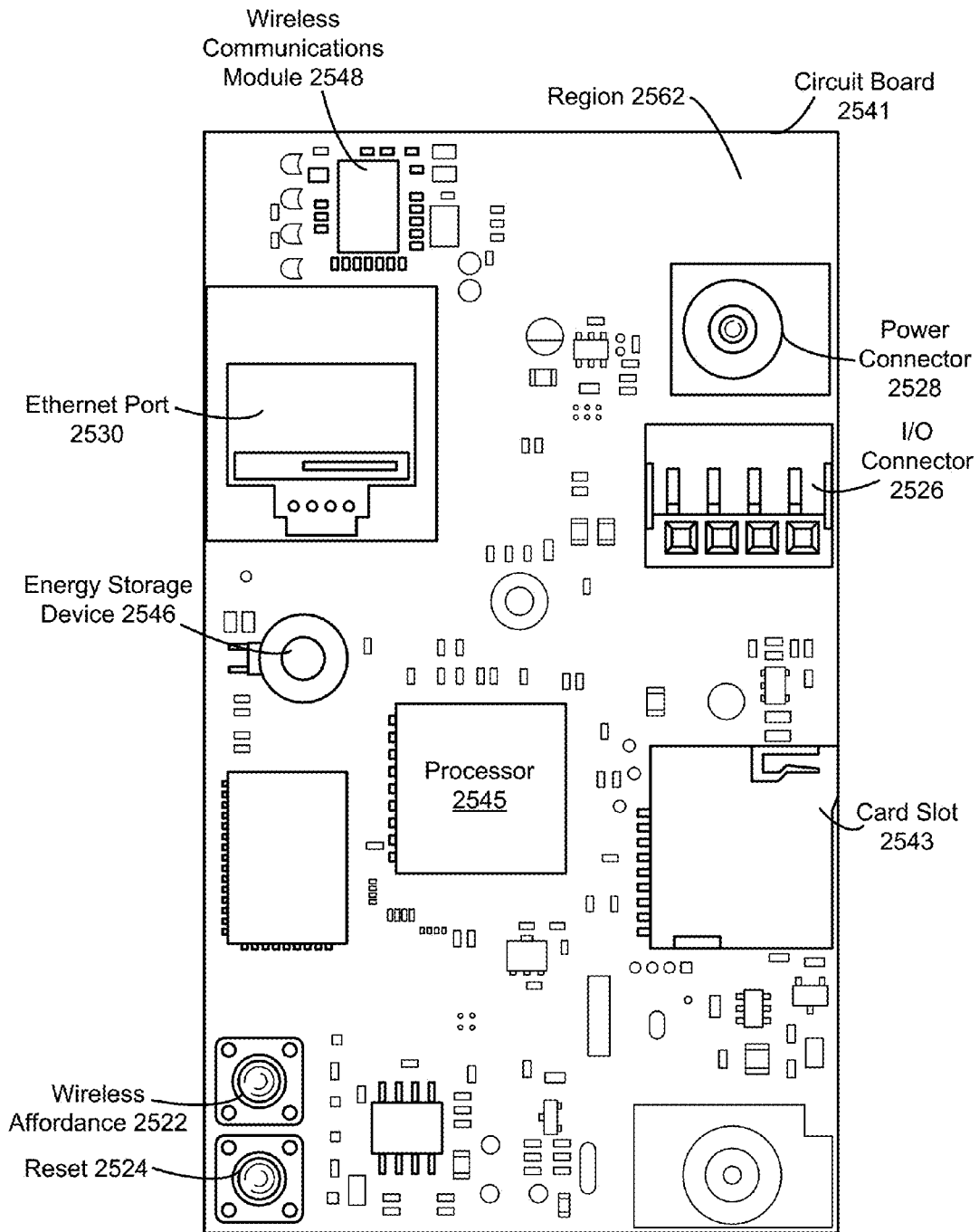


FIG. 25F

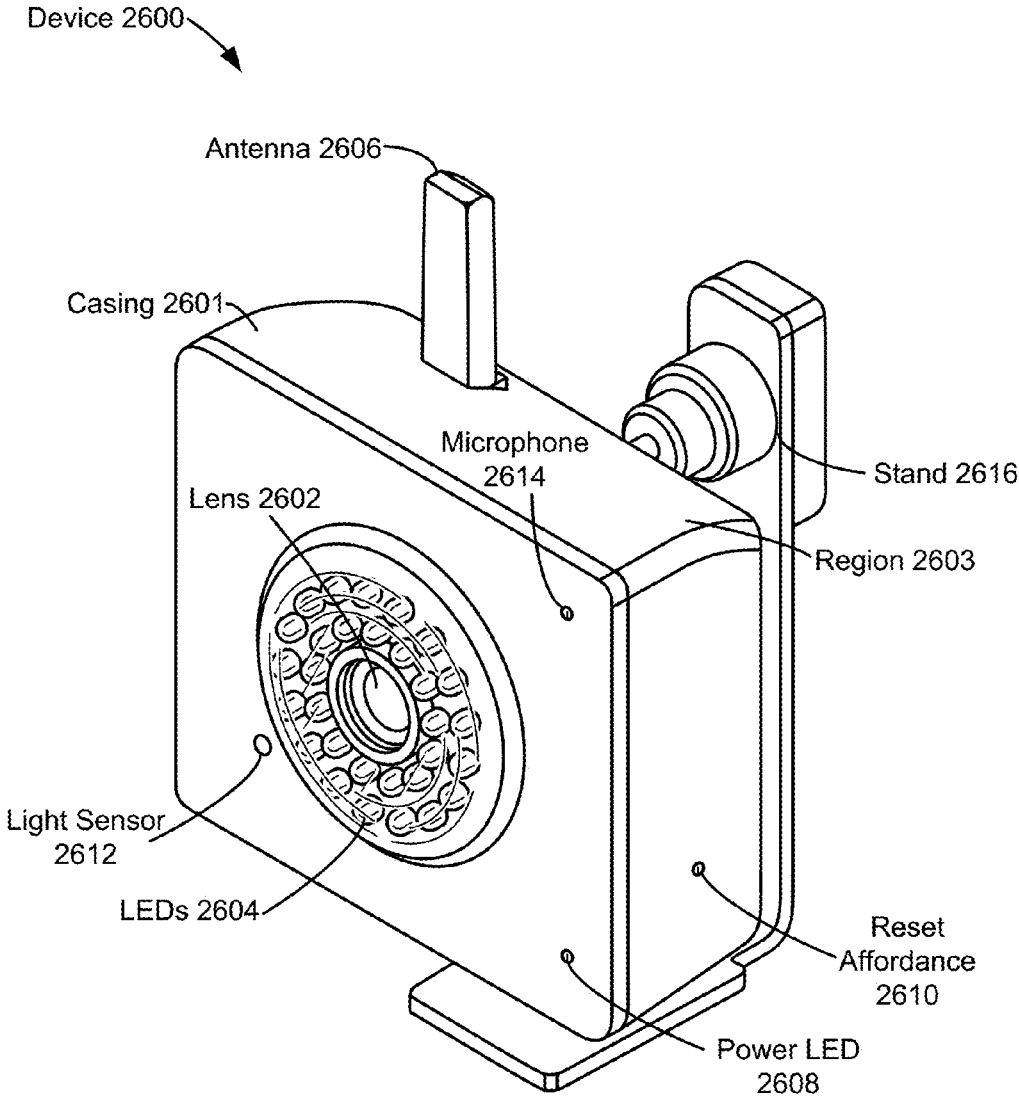


FIG. 26A

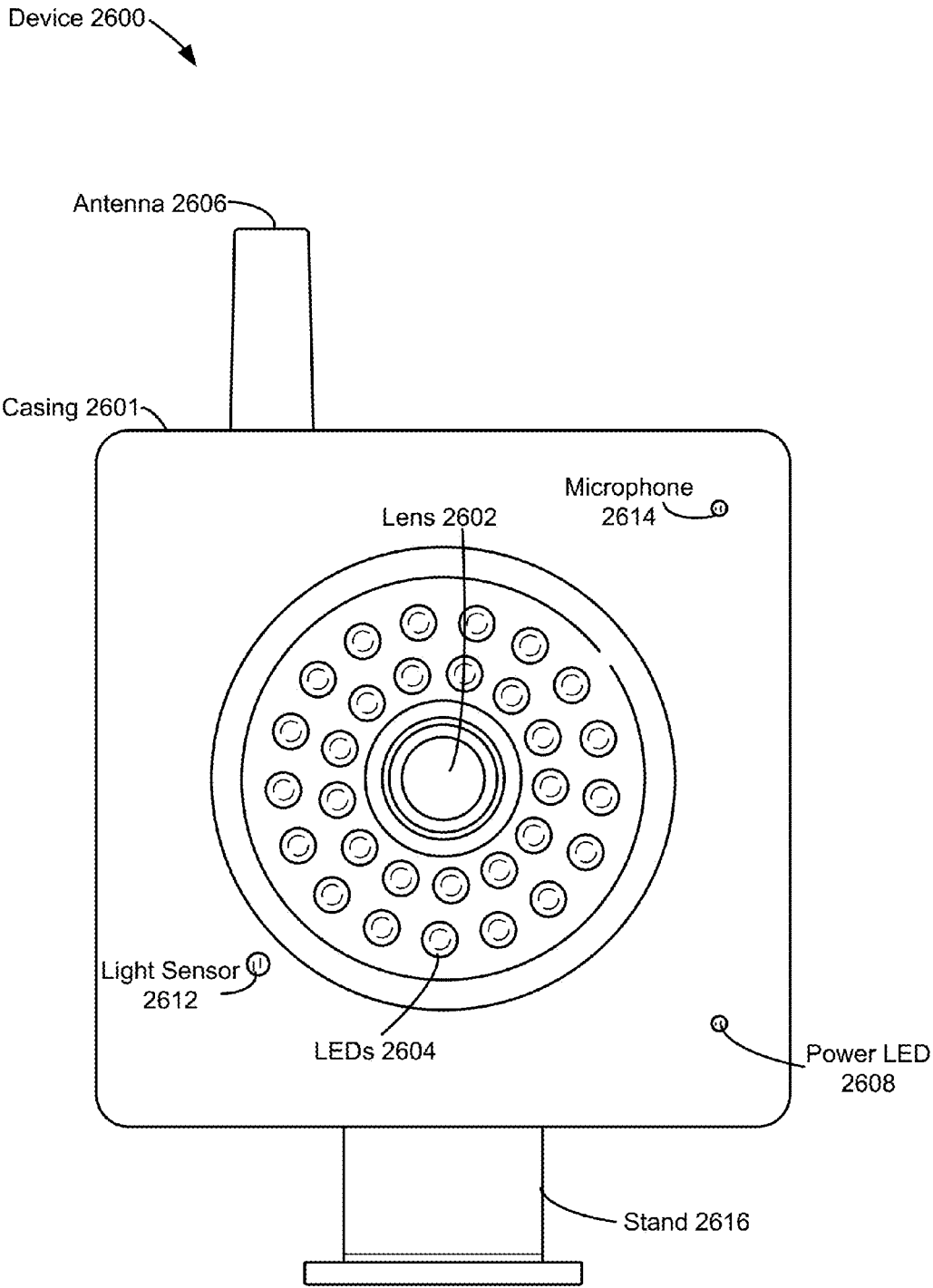


FIG. 26B

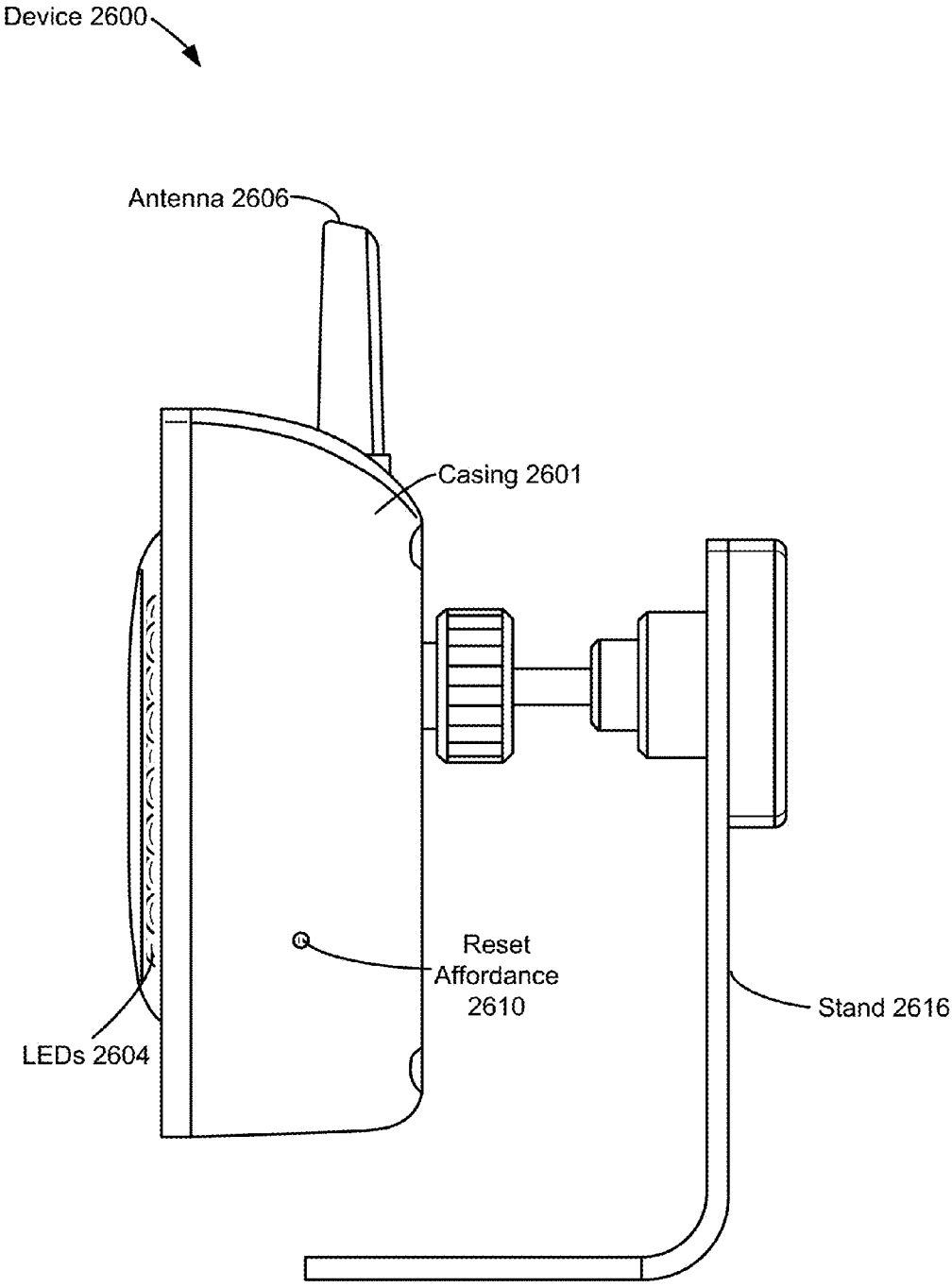


FIG. 26C

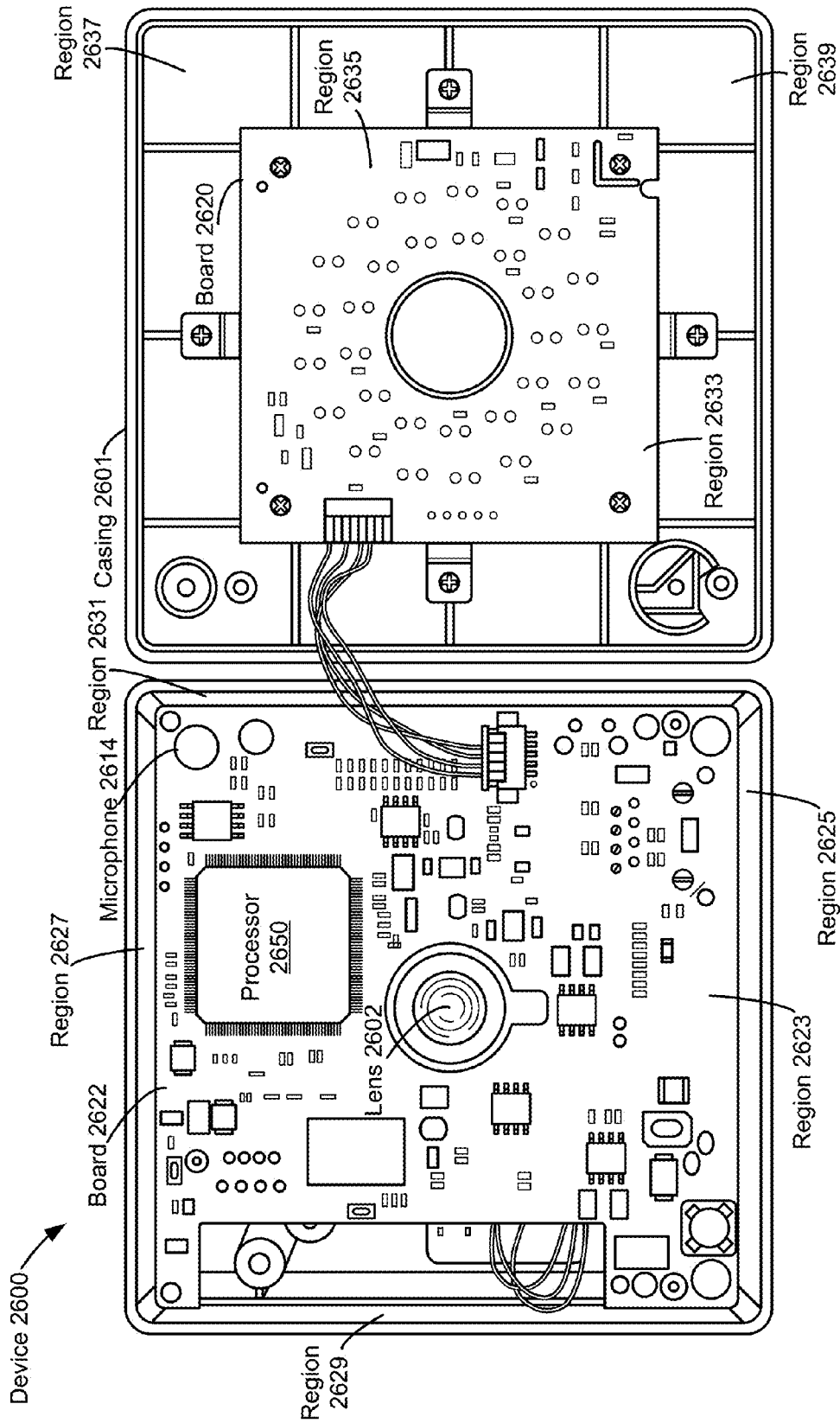


FIG. 26D

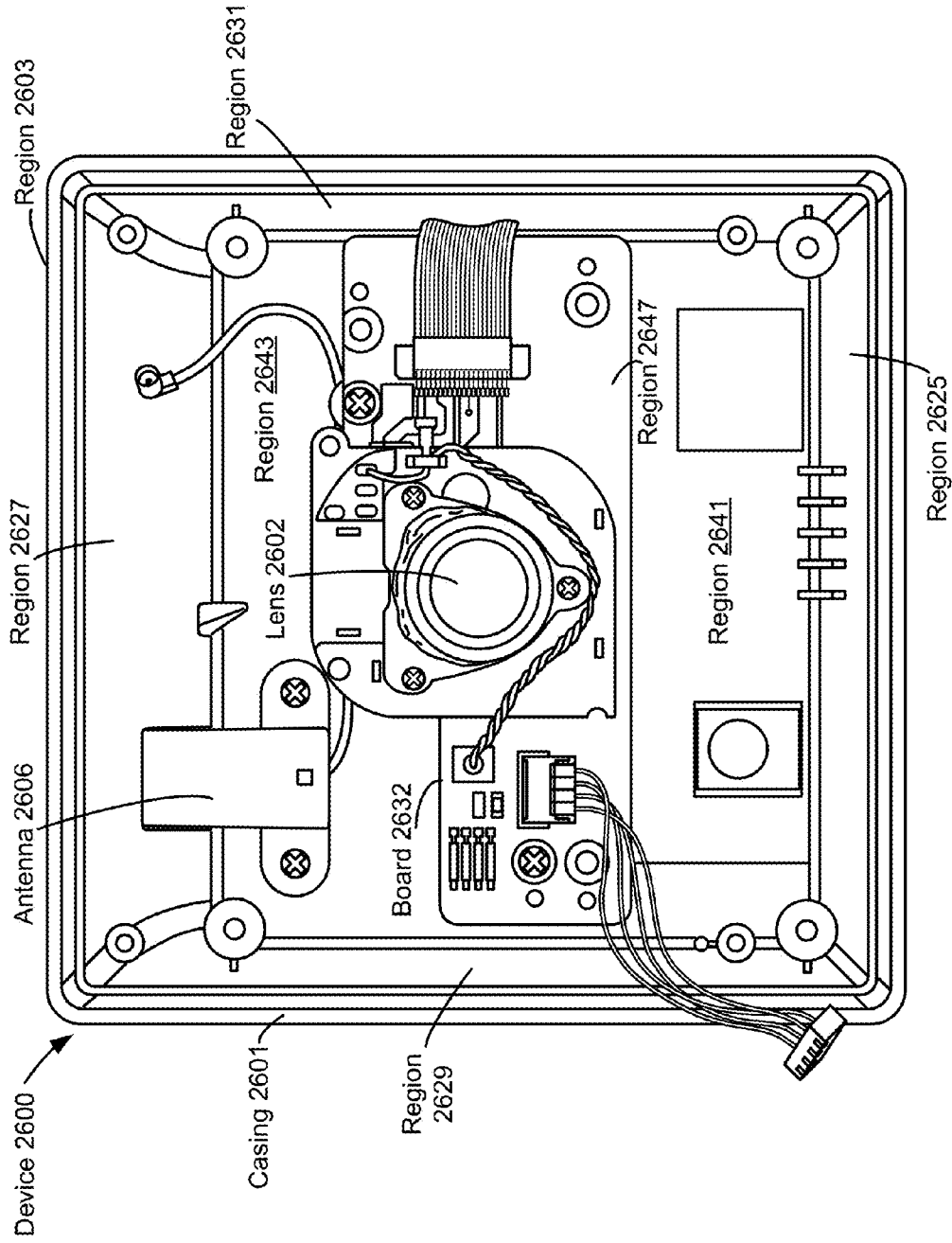


FIG. 26E

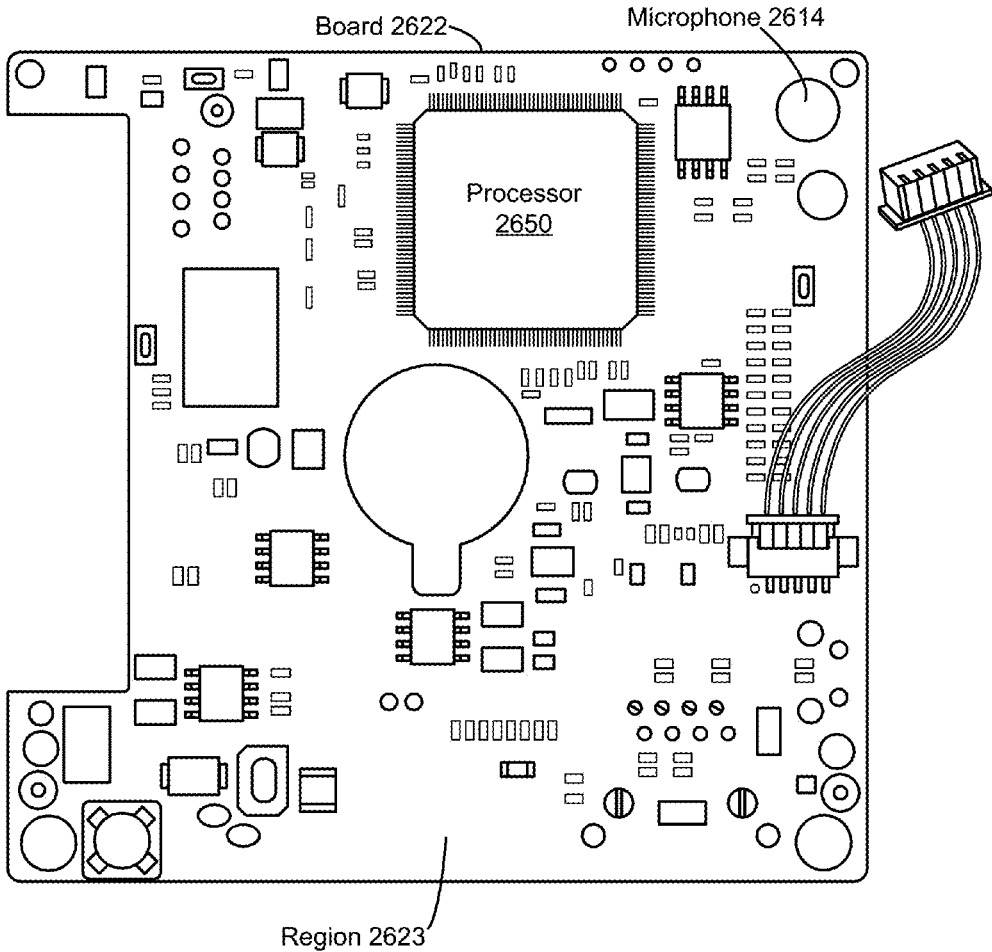


FIG. 26F



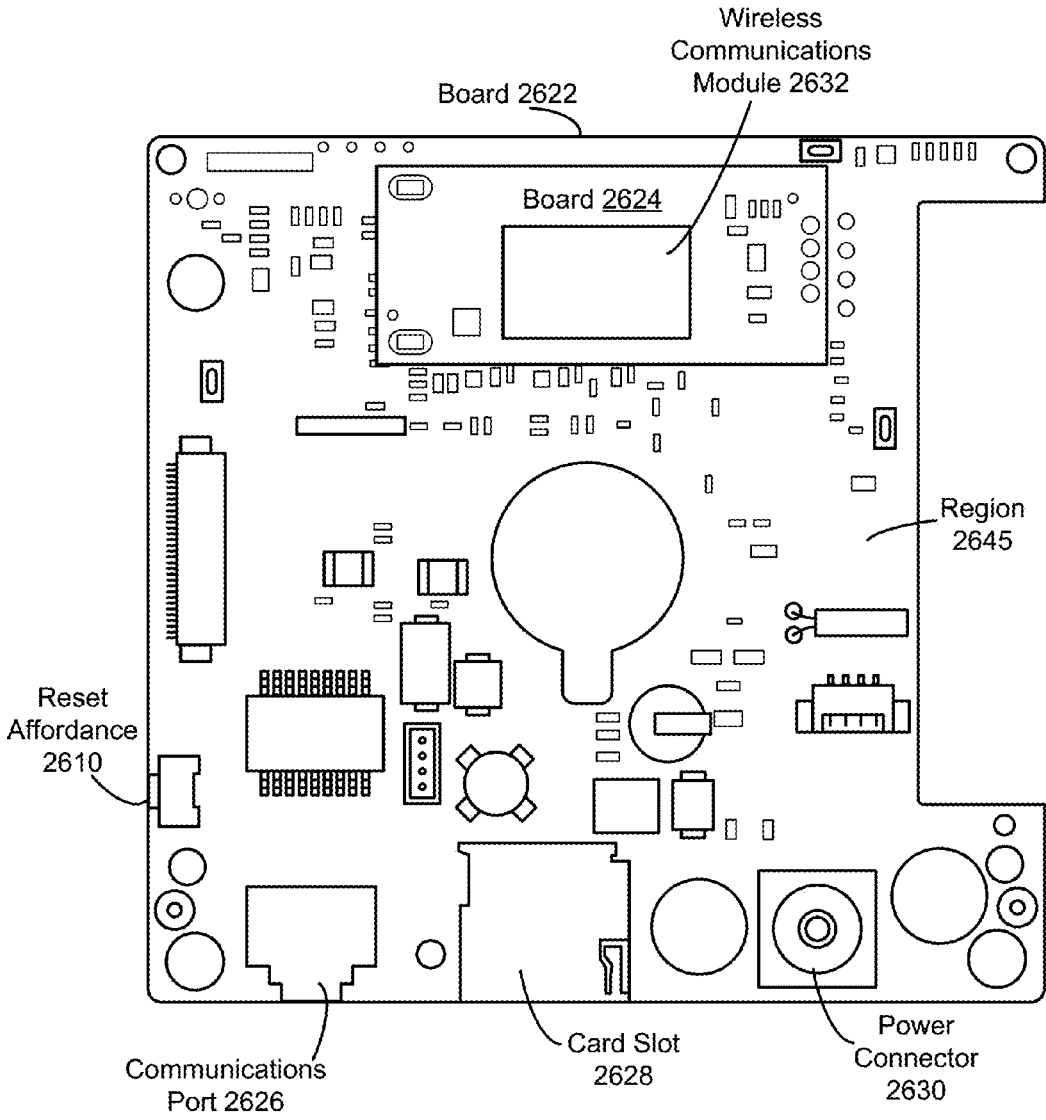


FIG. 26G

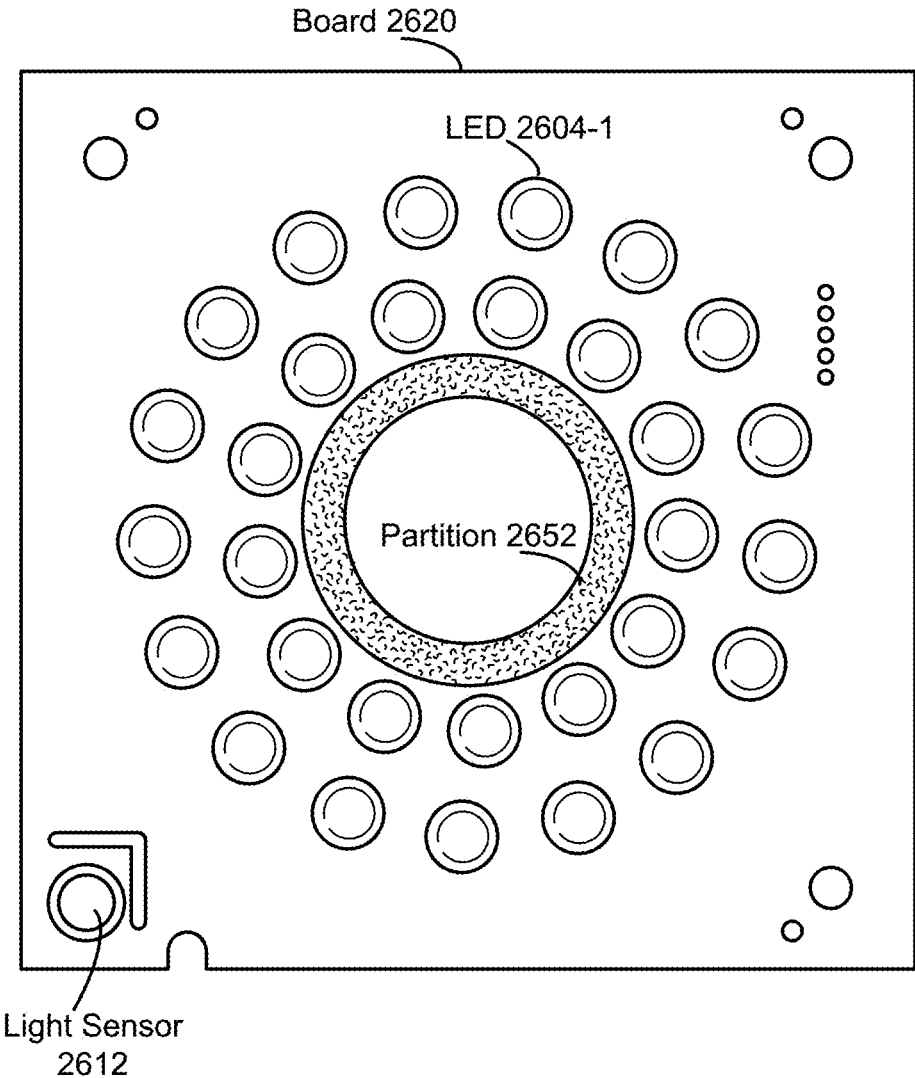


FIG. 26H

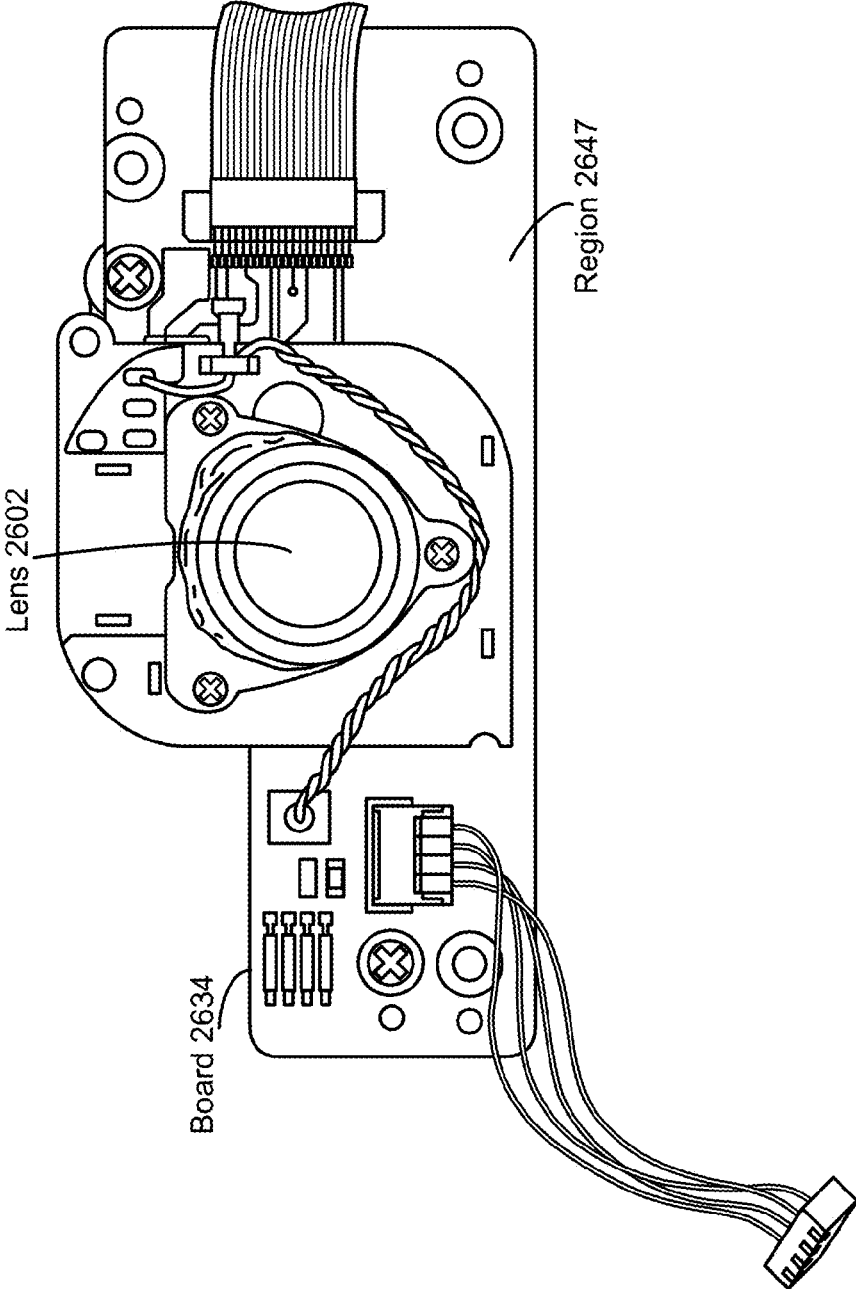


FIG. 26I

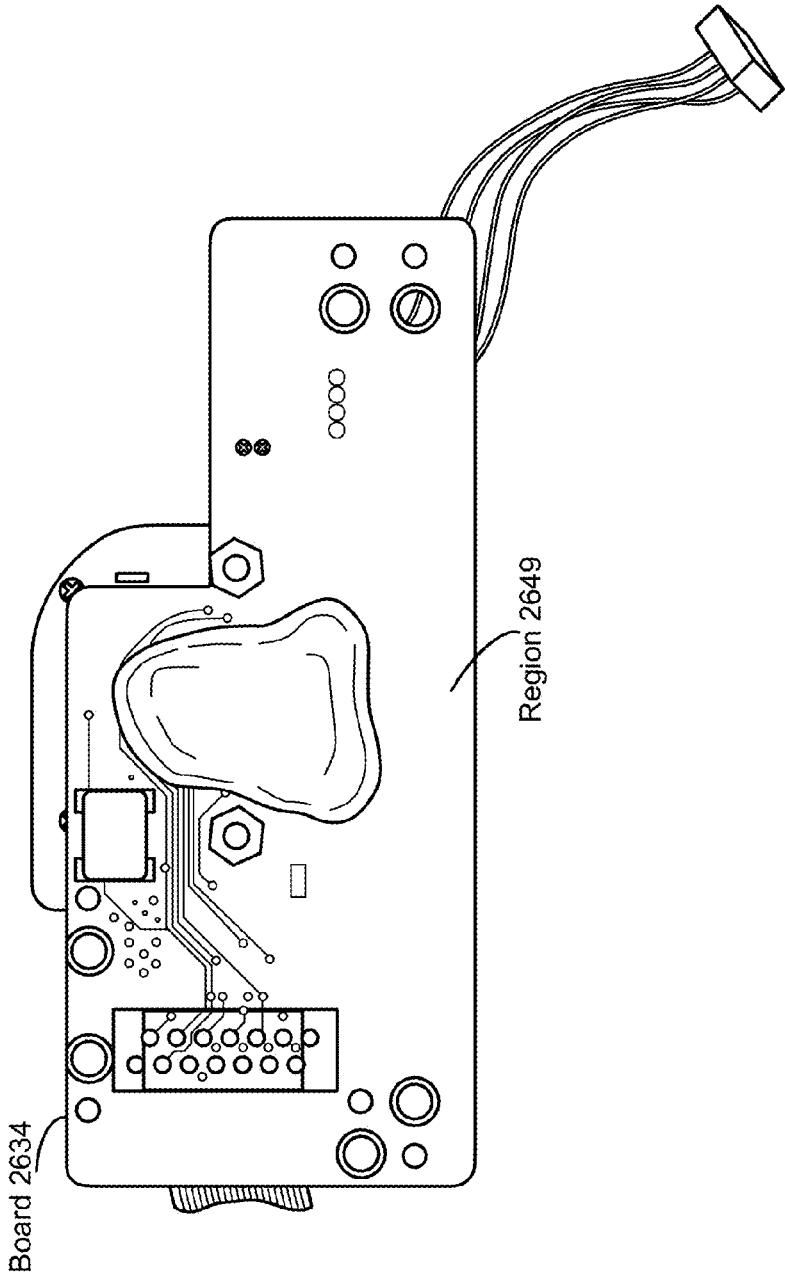


FIG. 26J

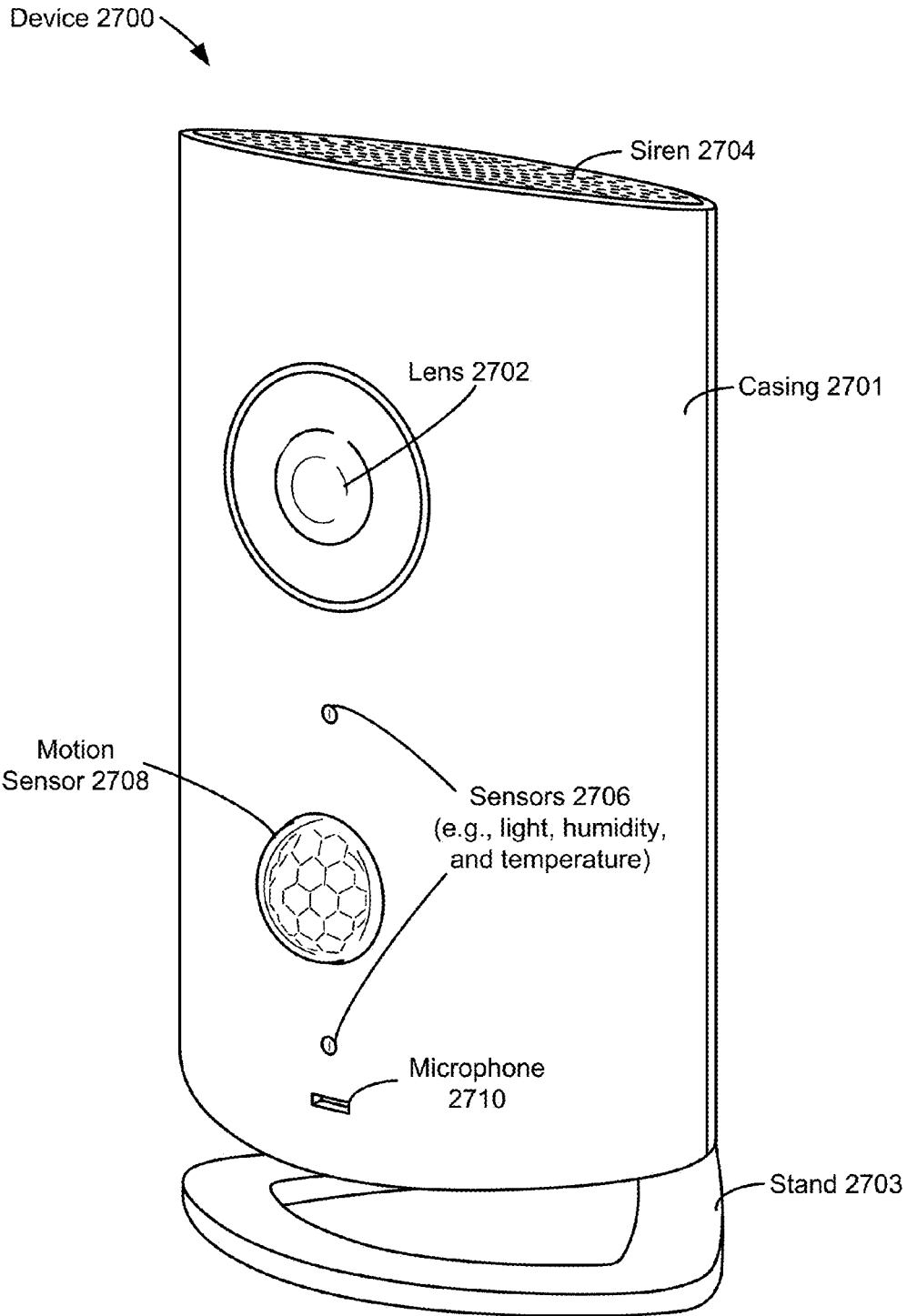


FIG. 27A

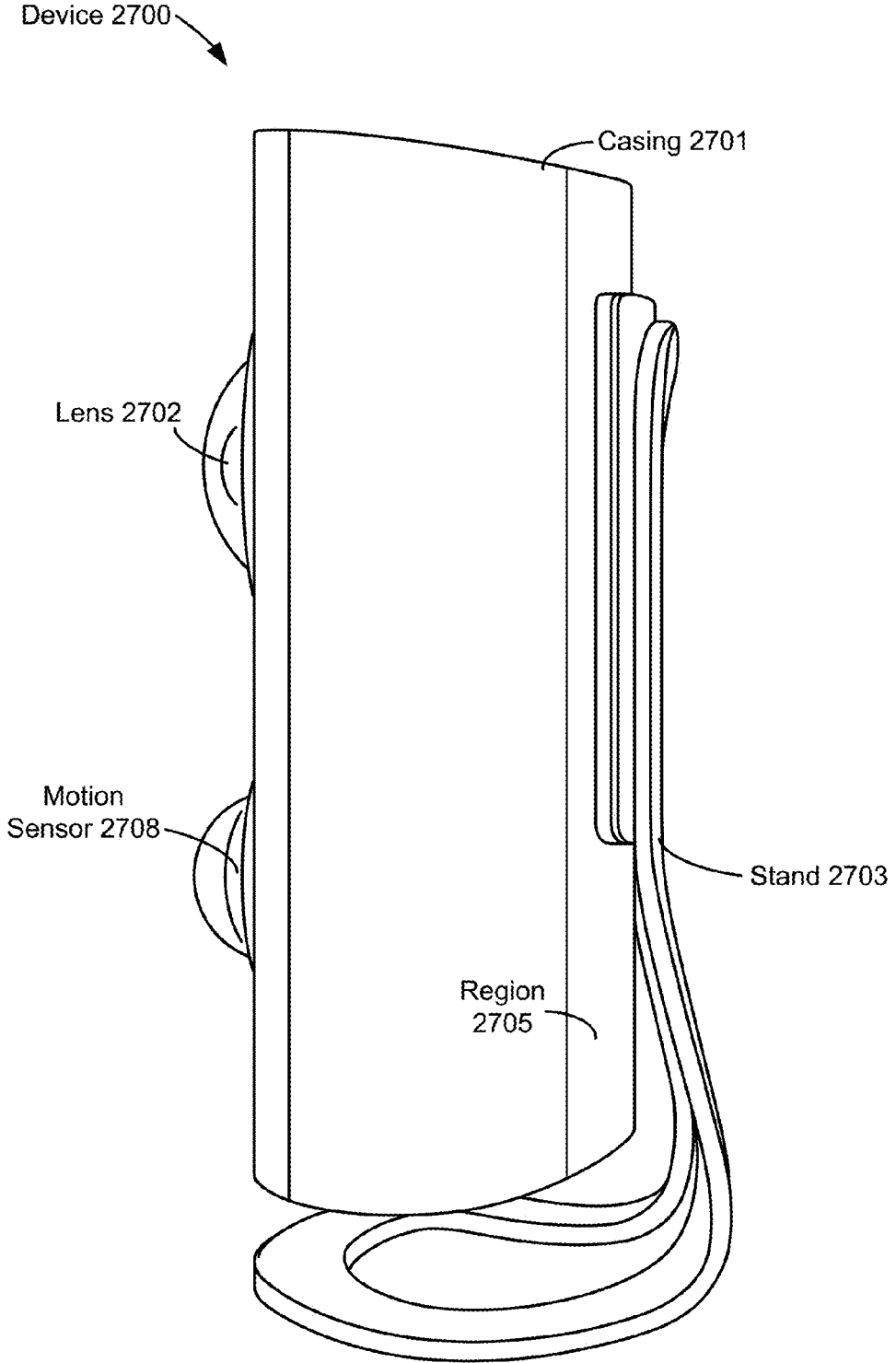


FIG. 27B

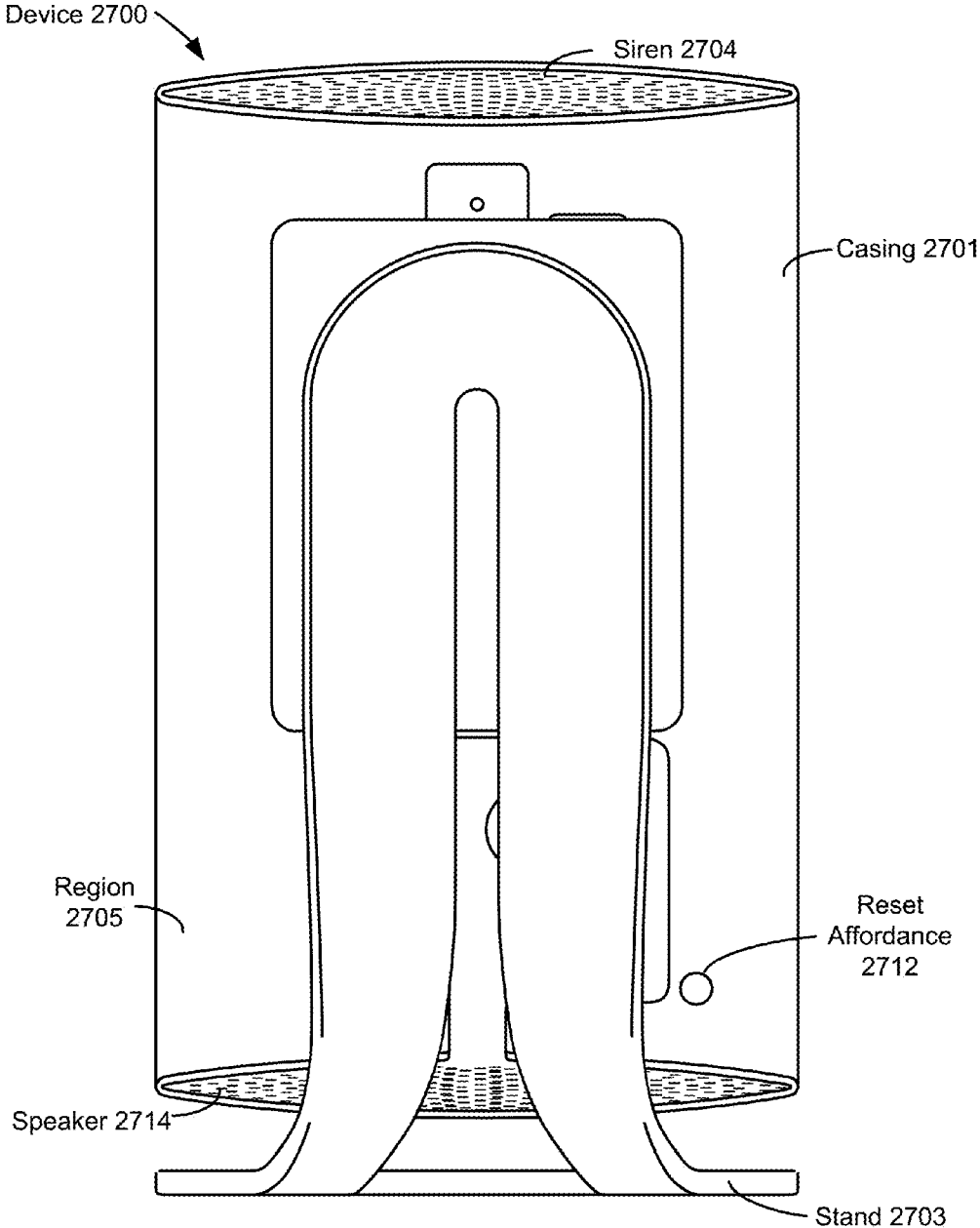


FIG. 27C

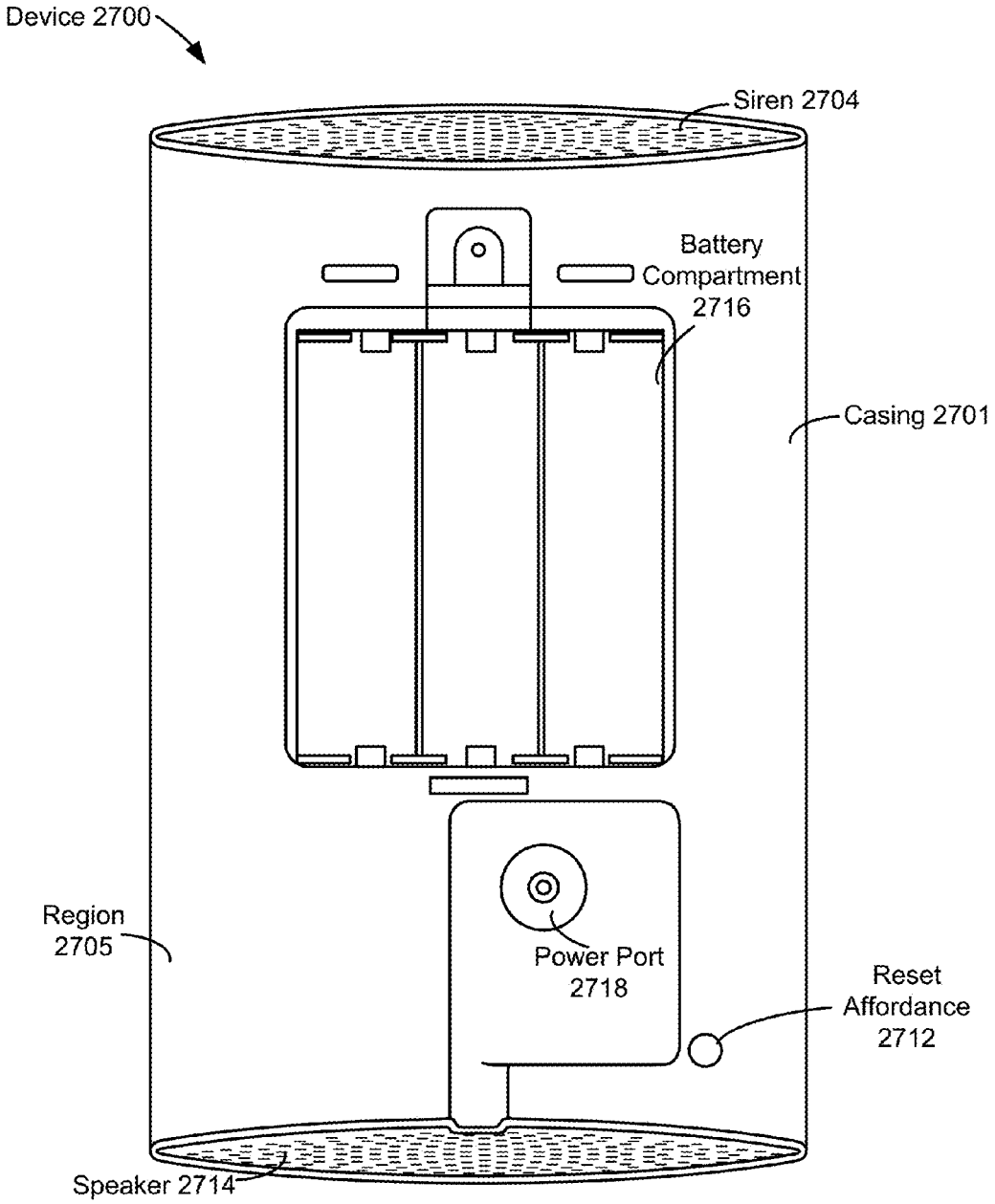


FIG. 27D



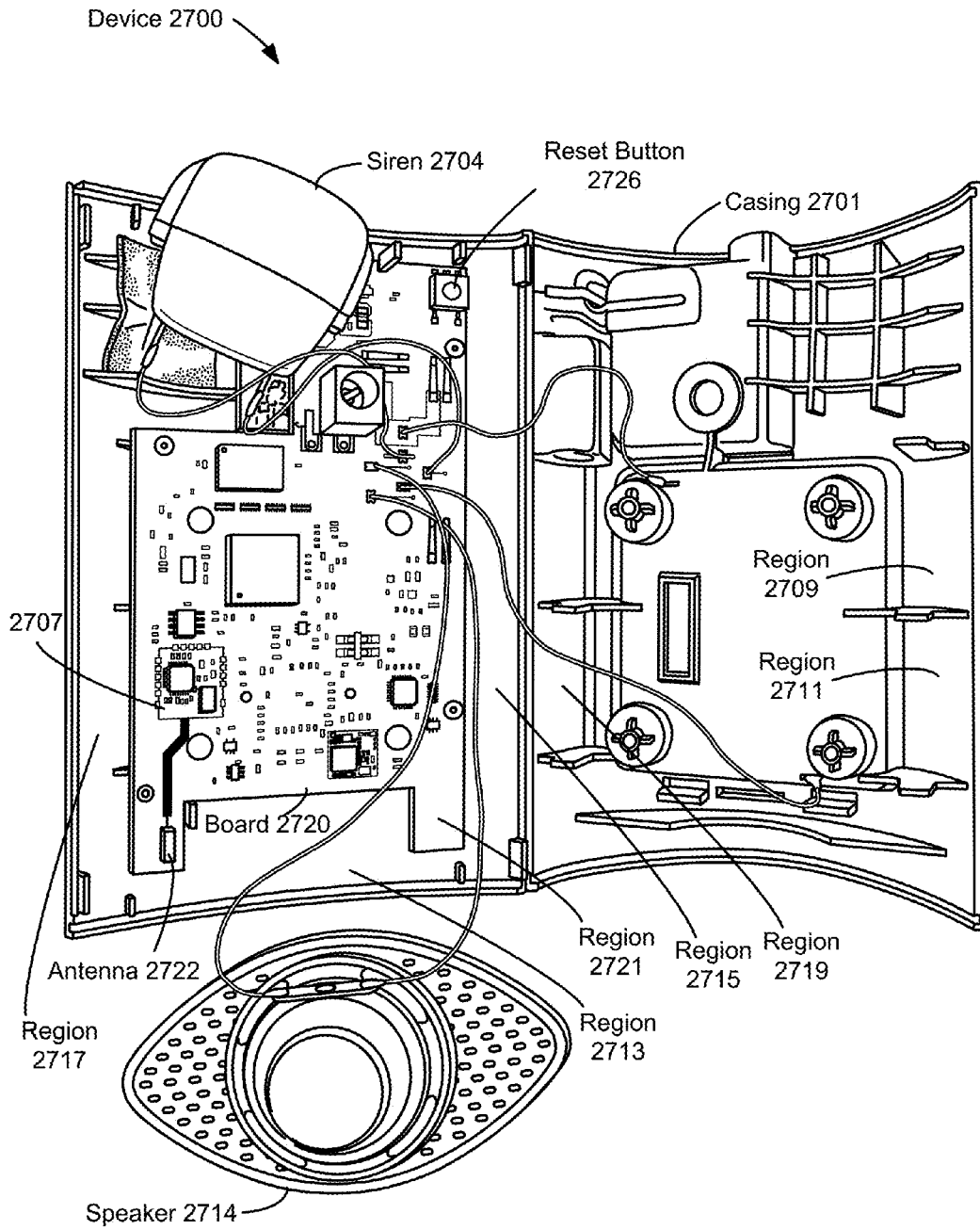


FIG. 27E

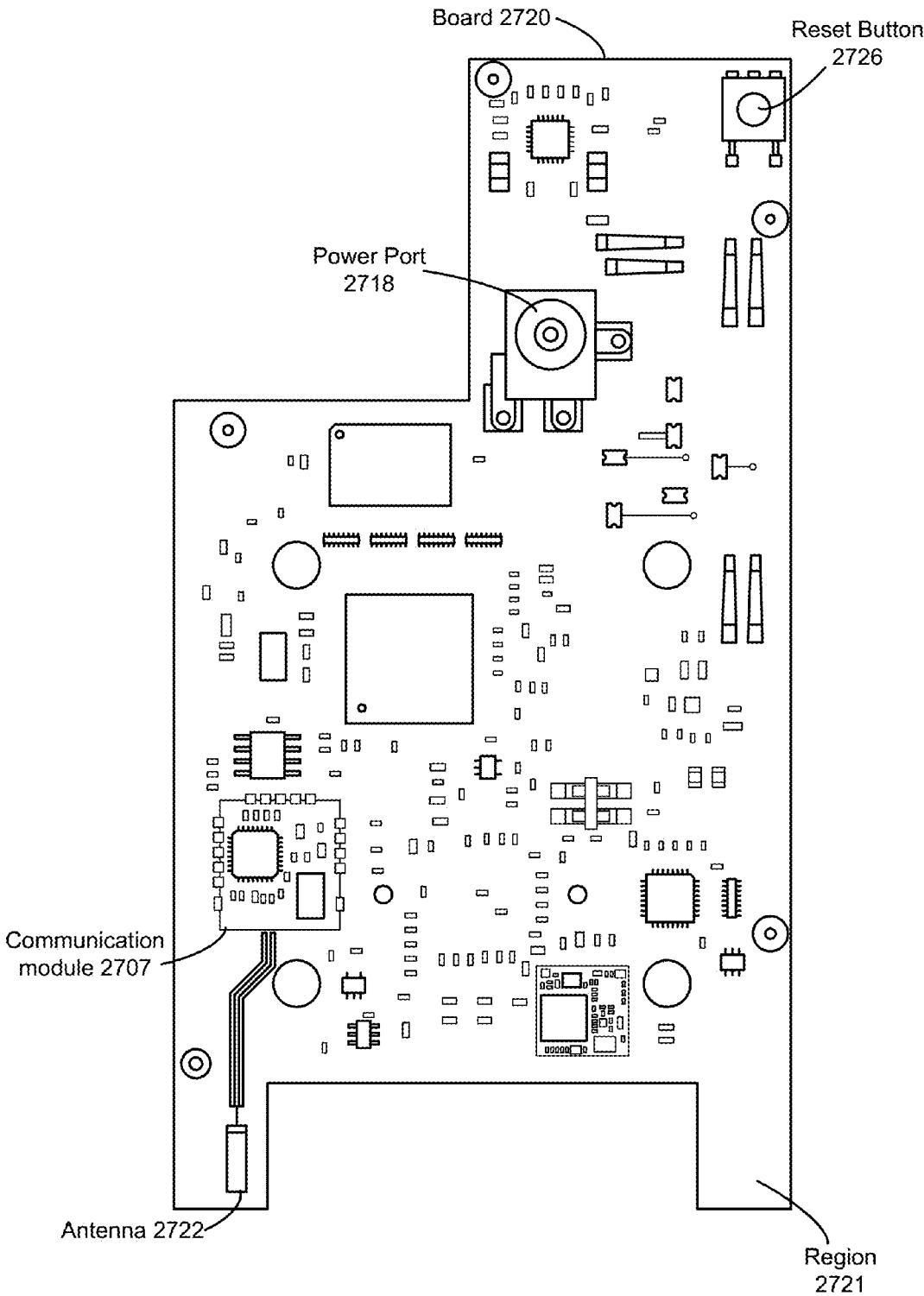


FIG. 27F

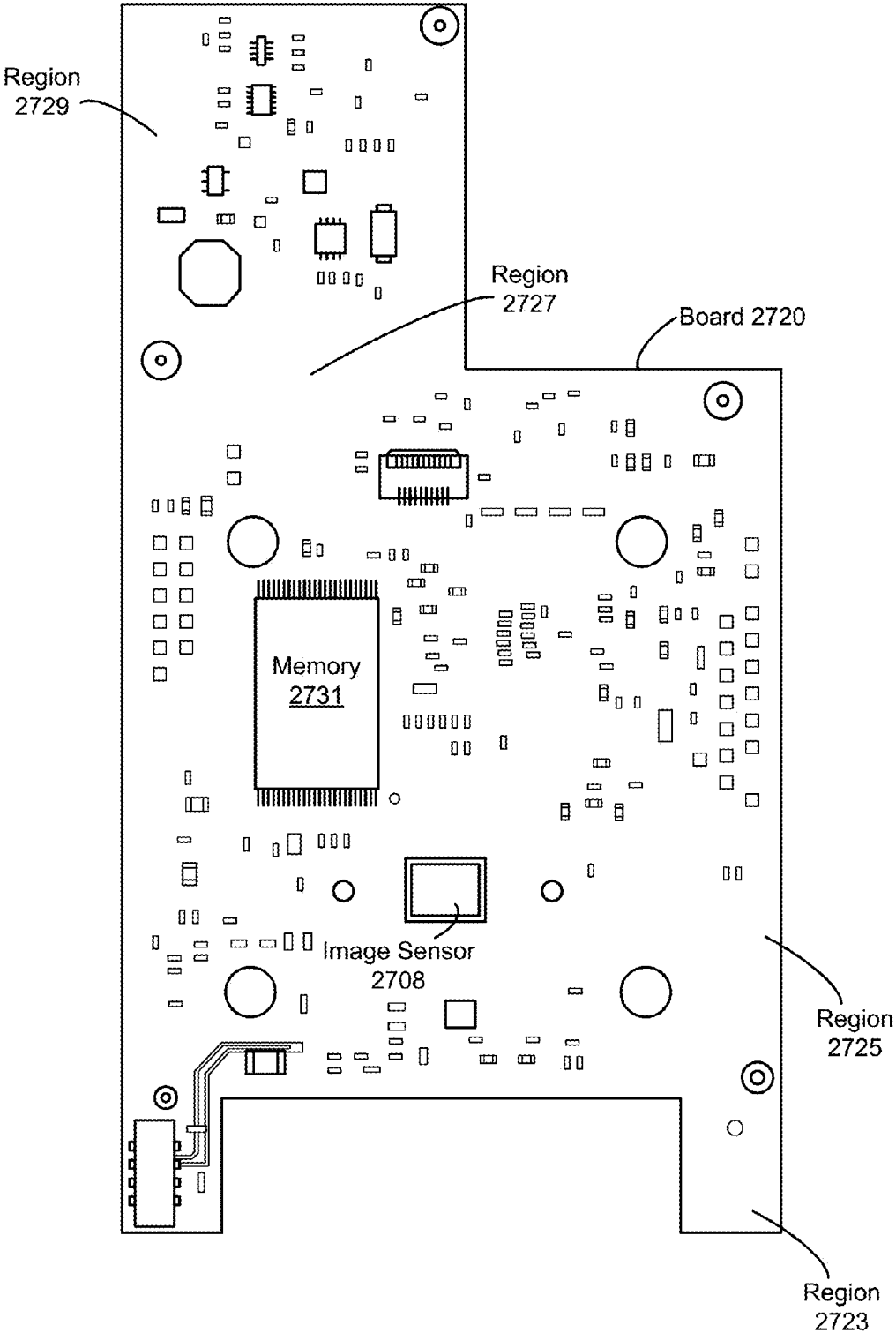


FIG. 27G

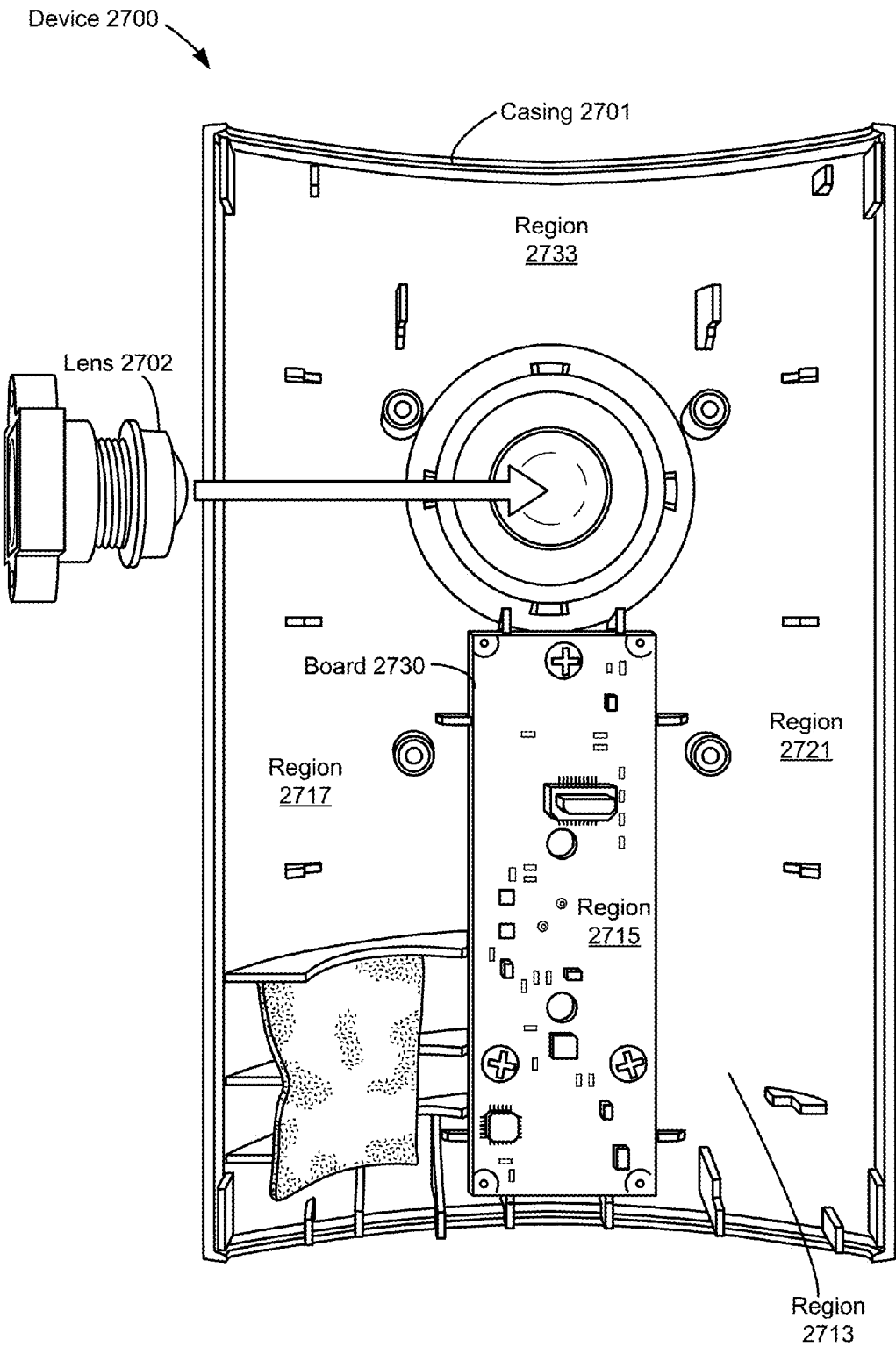


FIG. 27H

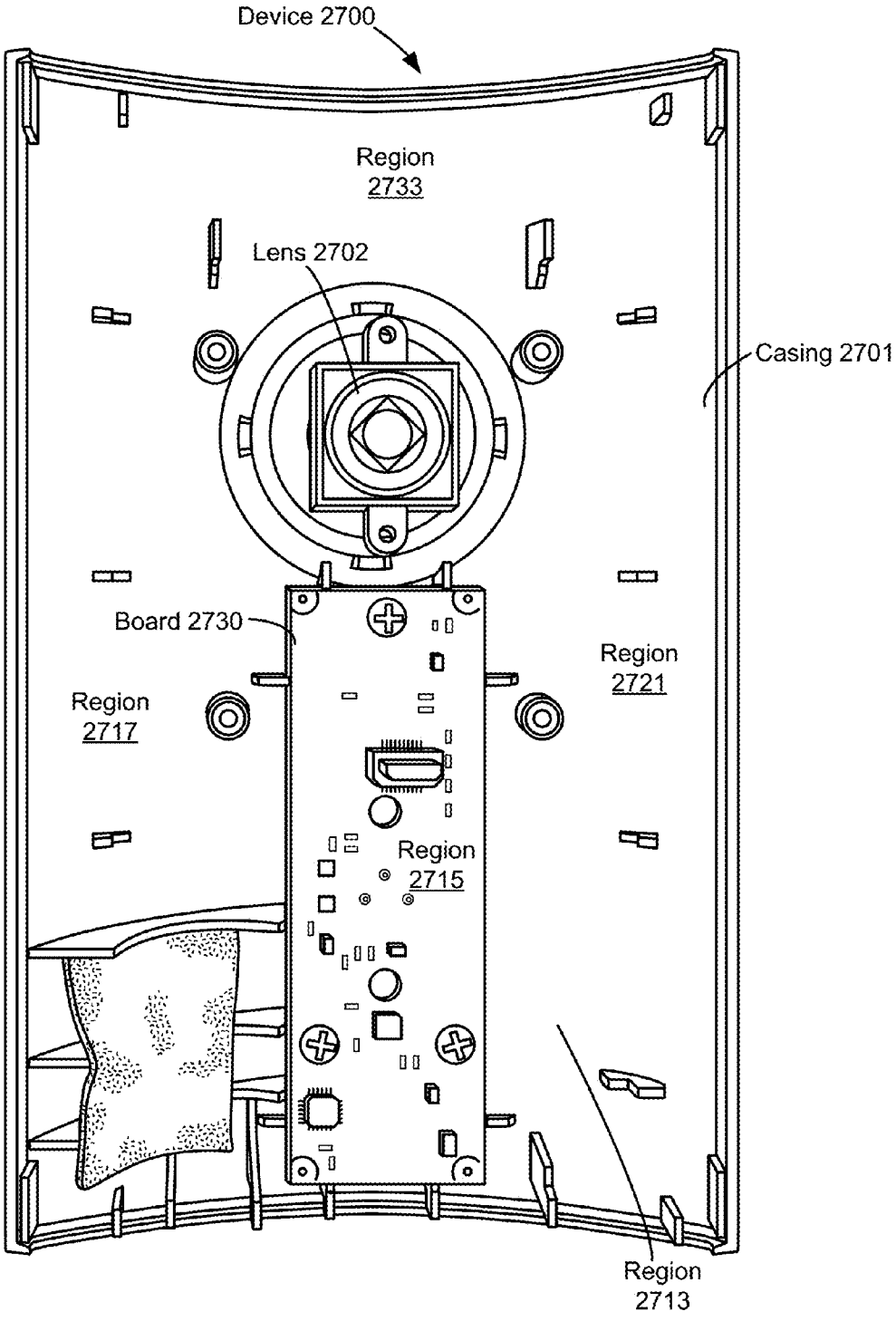


FIG. 271

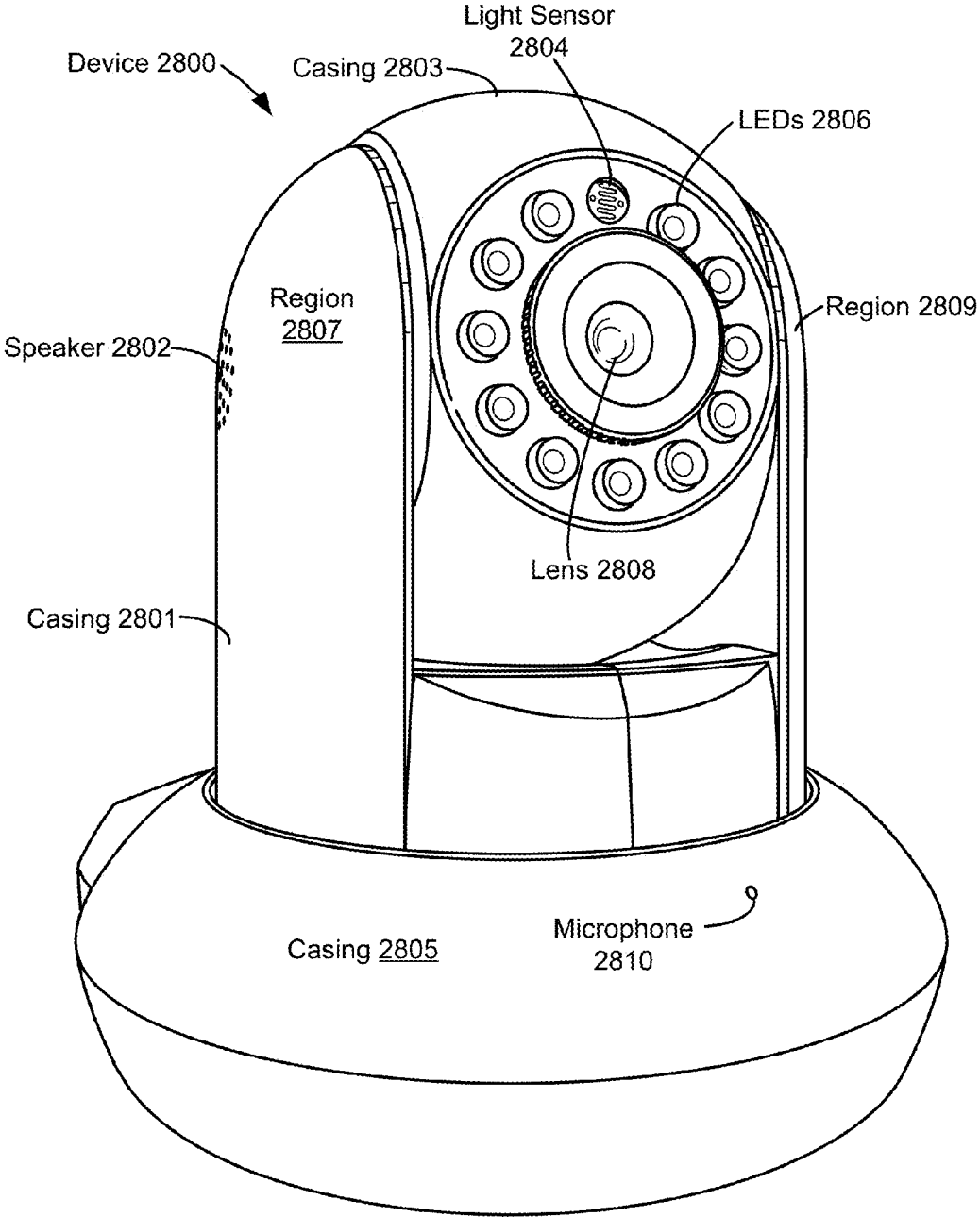


FIG. 28A

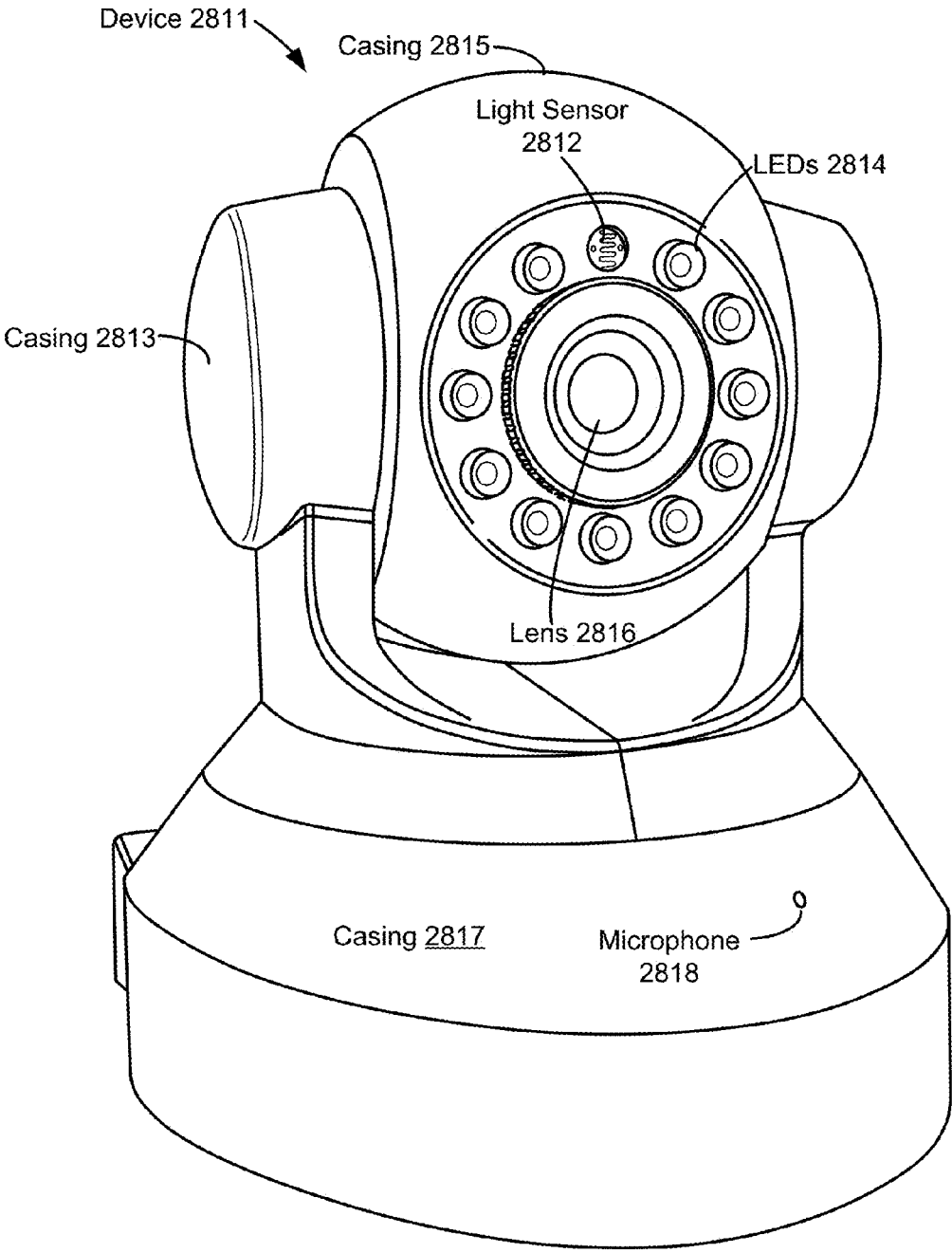


FIG. 28B

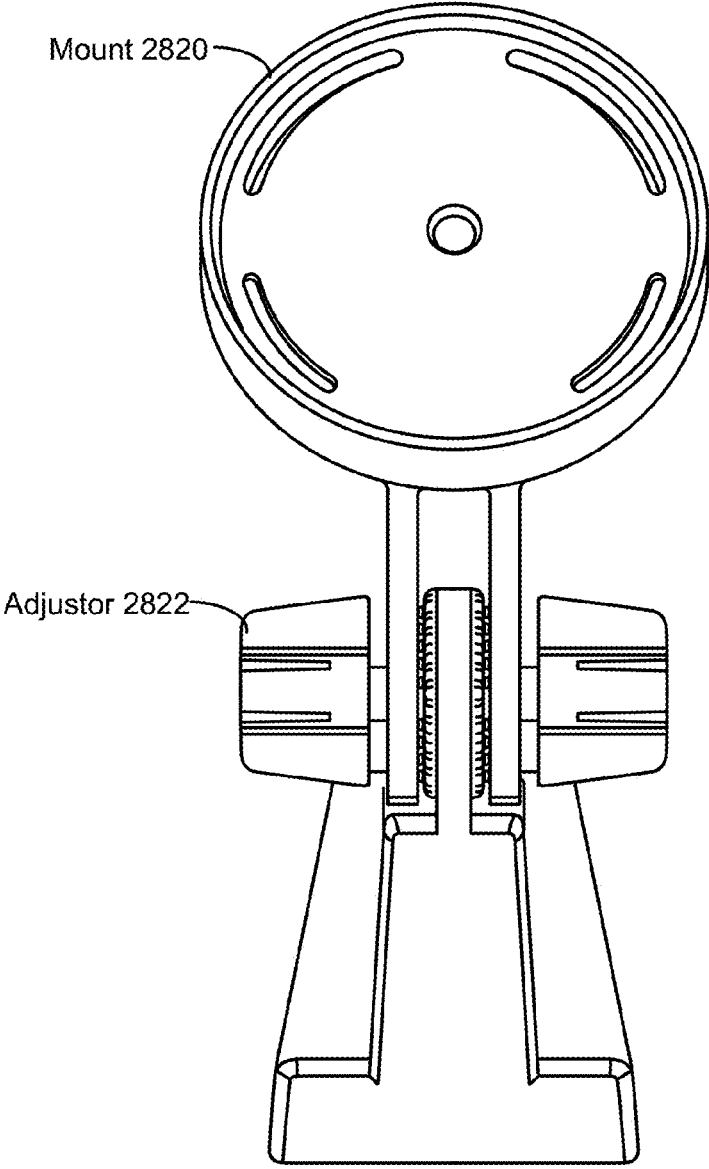


FIG. 28C



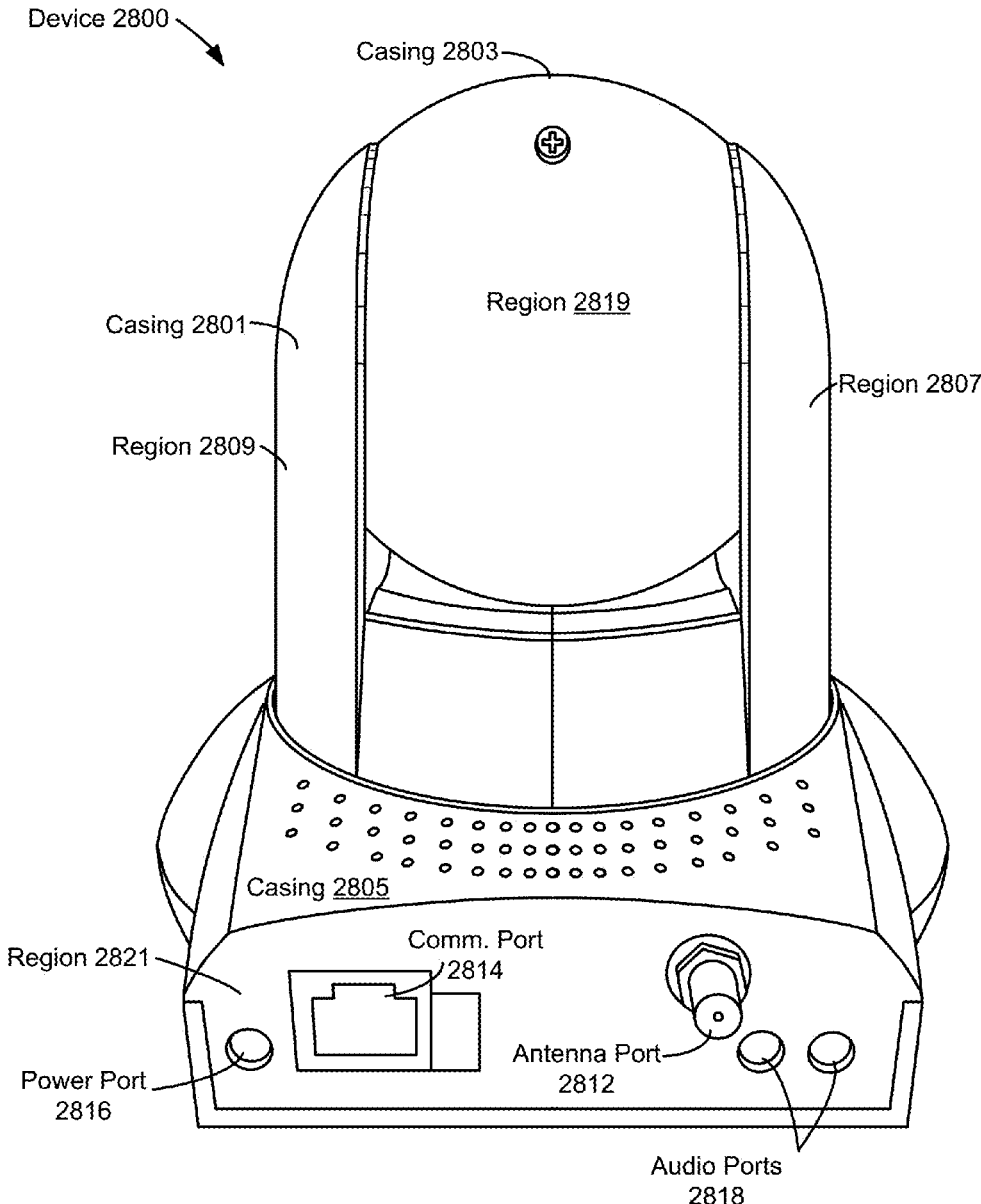


FIG. 28D

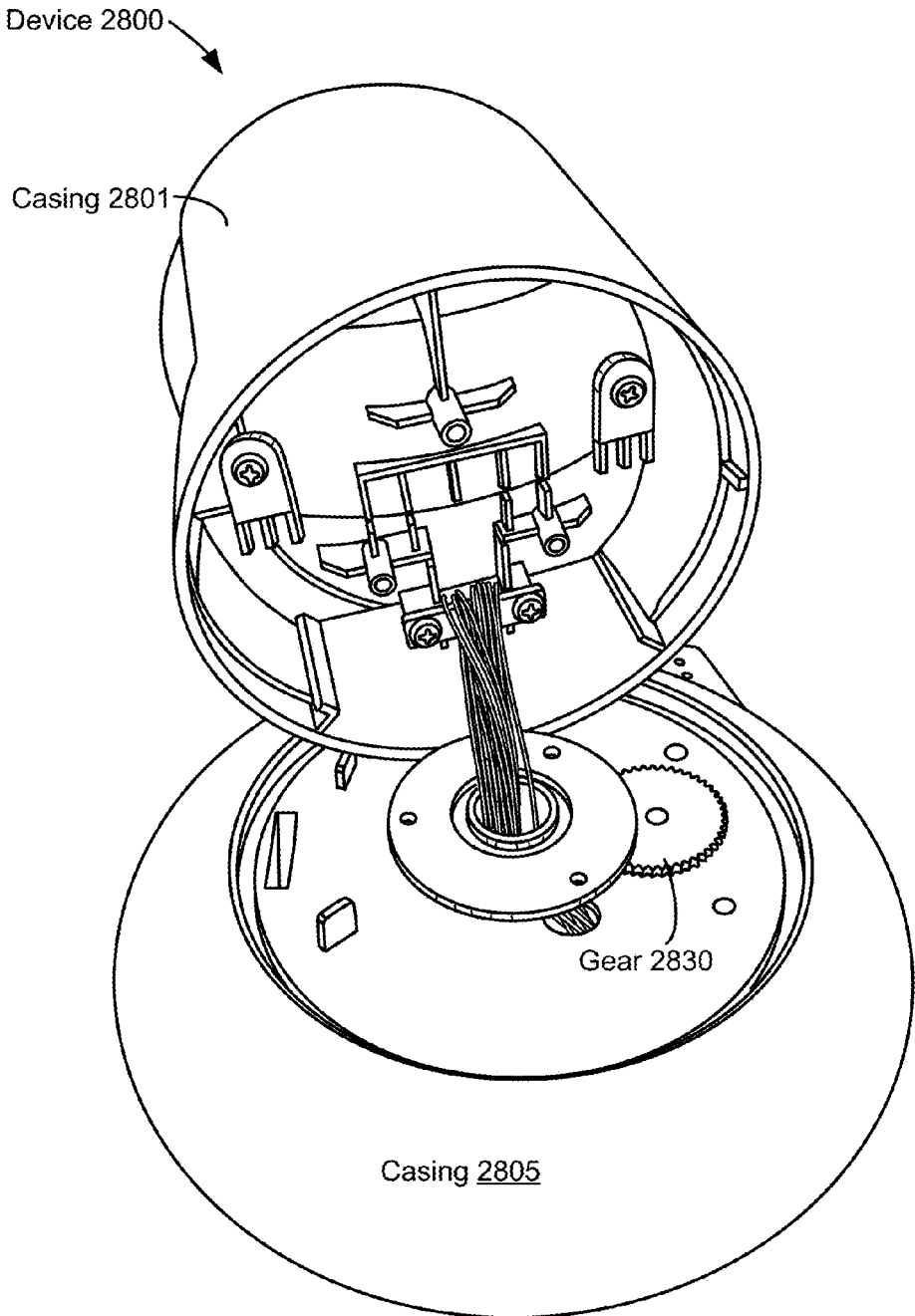


FIG. 28E

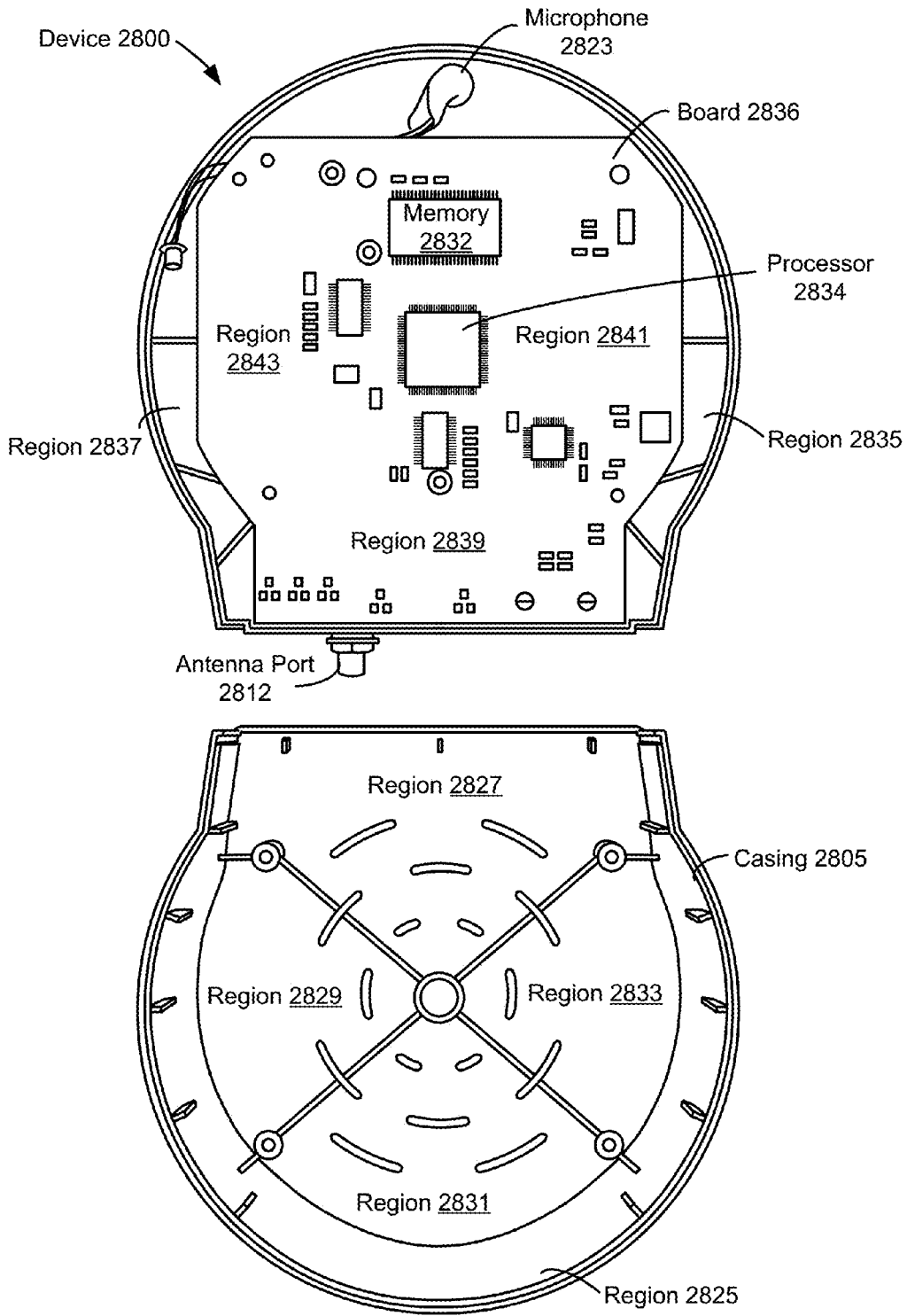


FIG. 28F

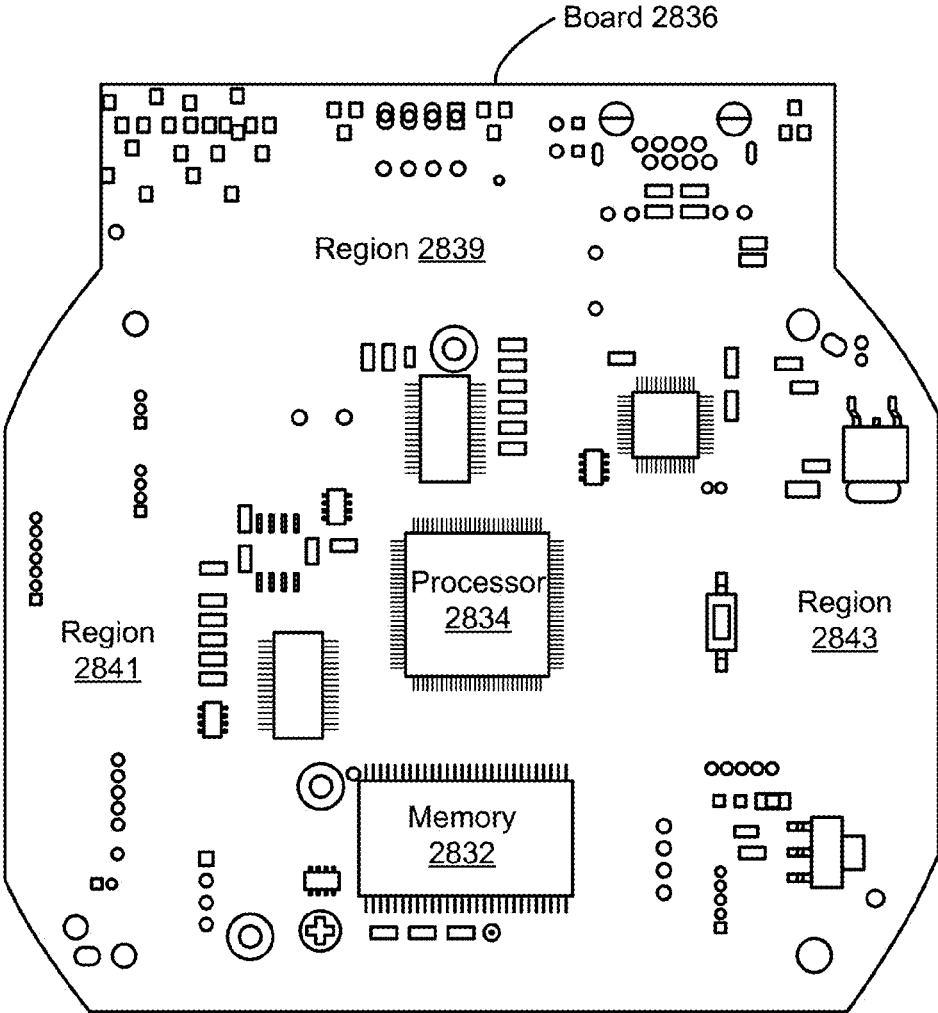


FIG. 28G

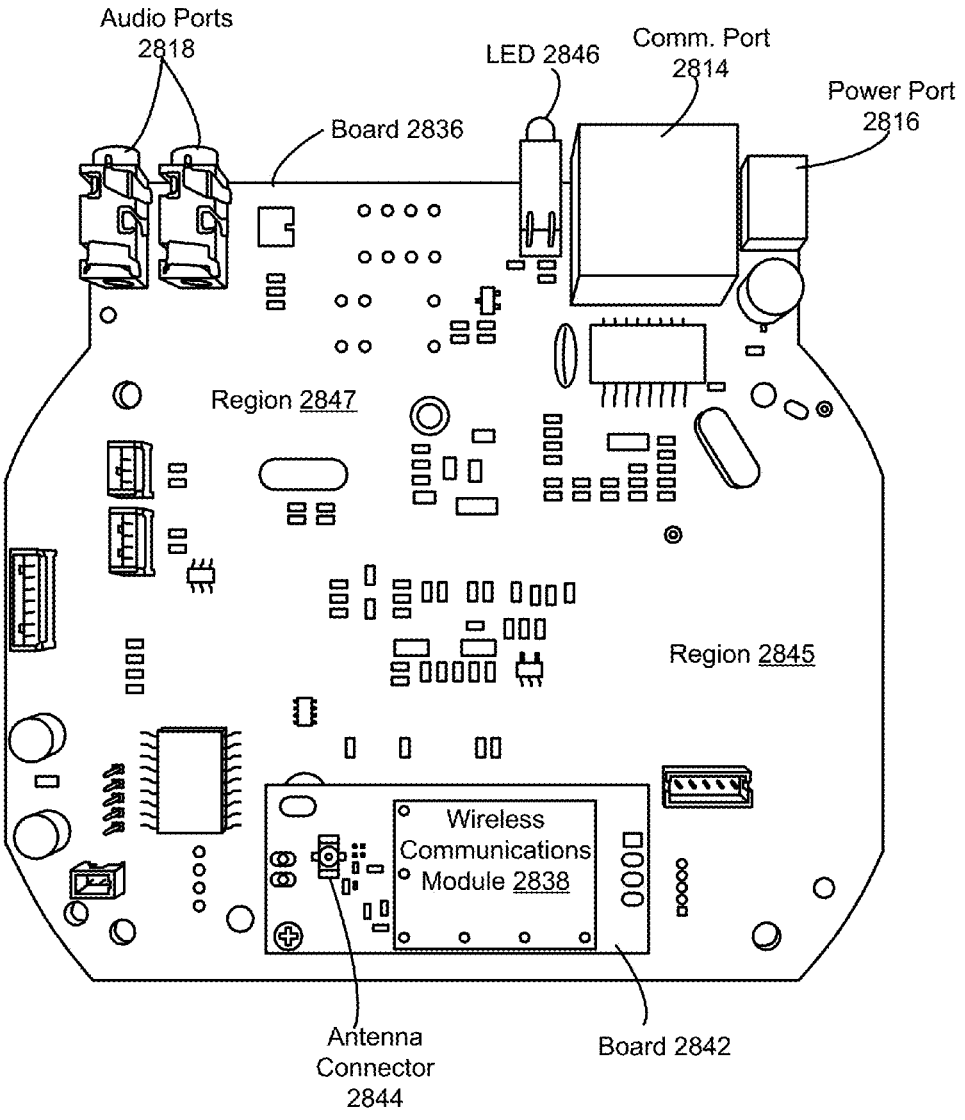


FIG. 28H

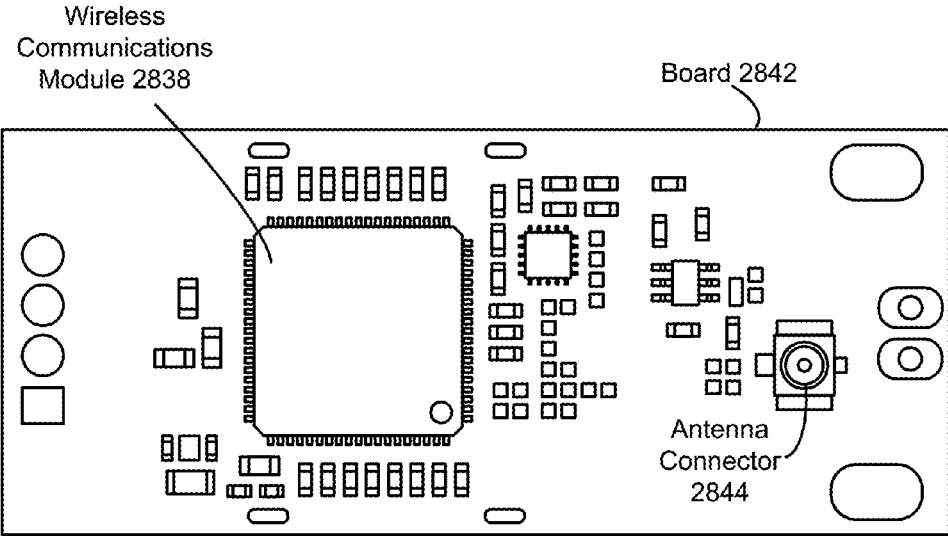


FIG. 28I

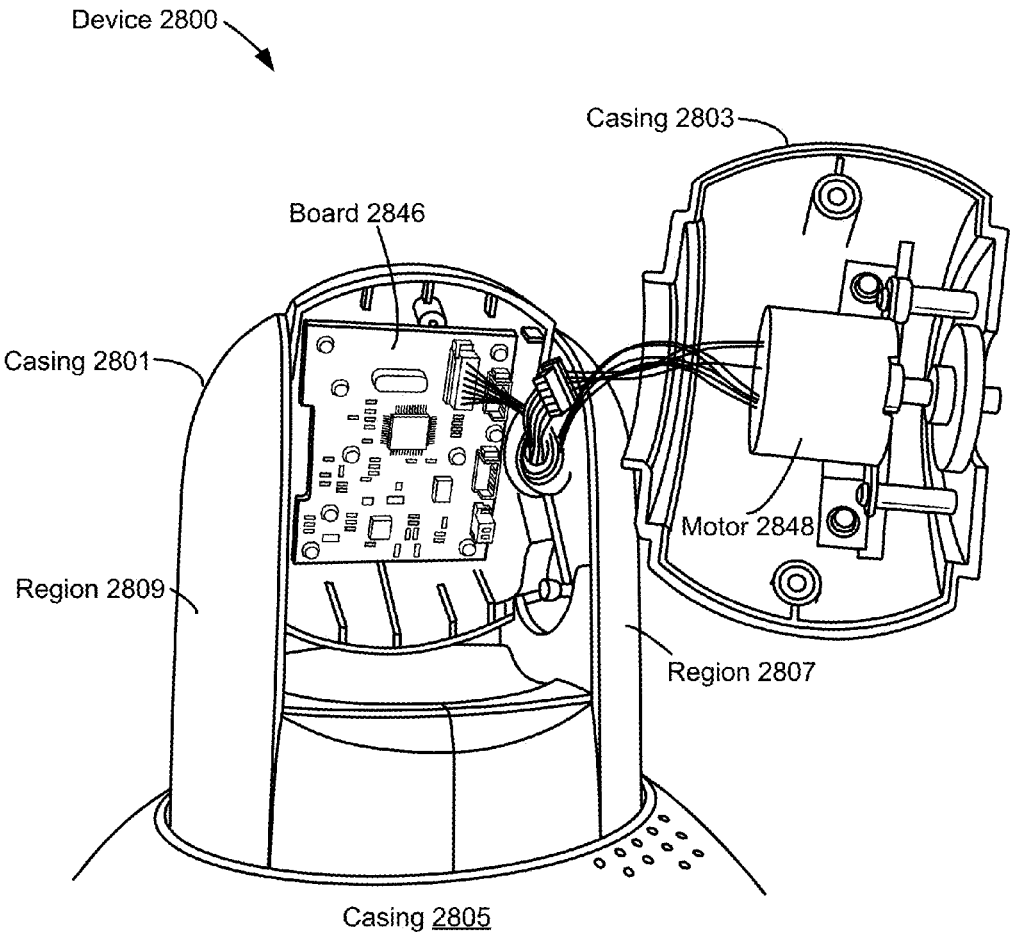


FIG. 28J

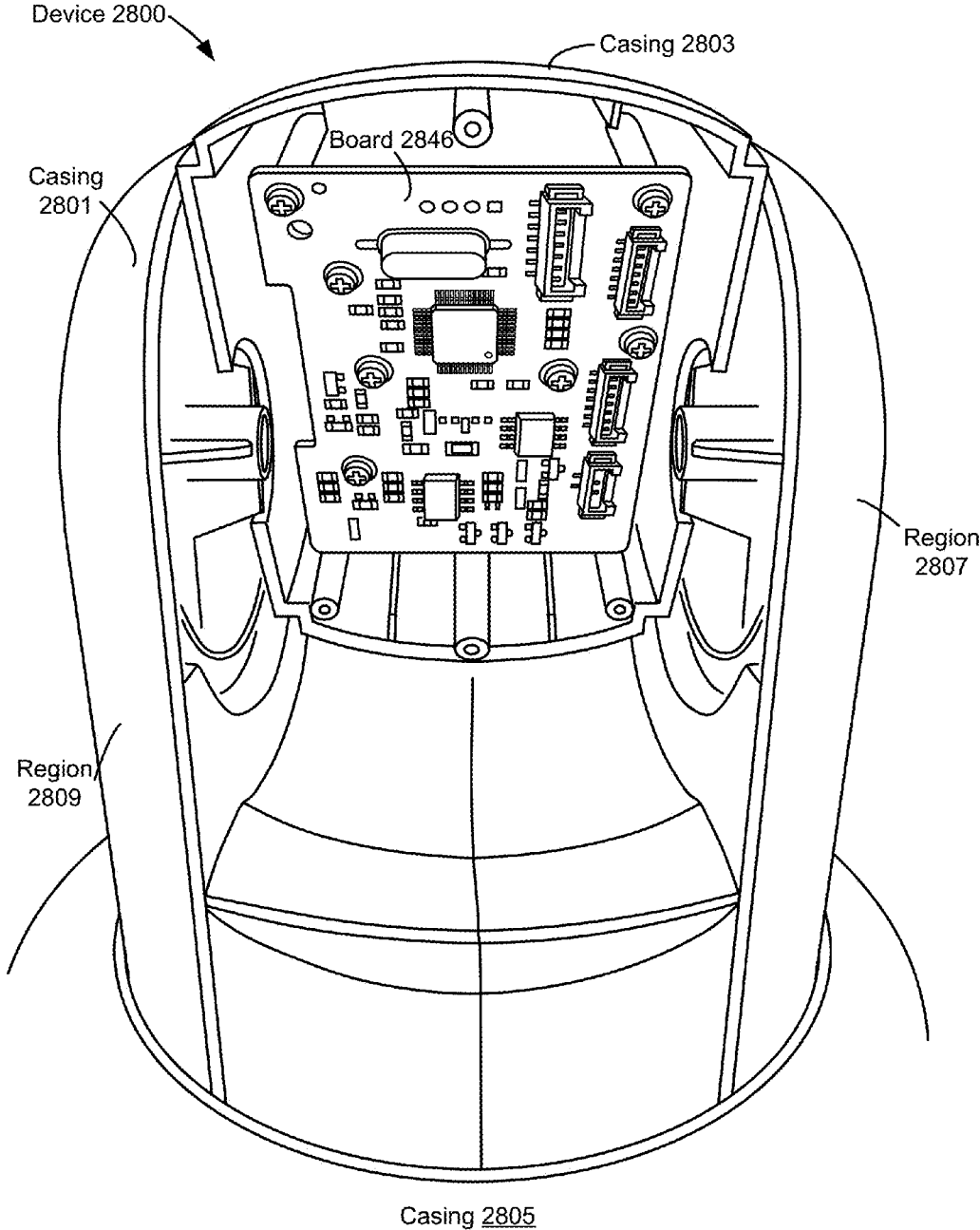


FIG. 28K



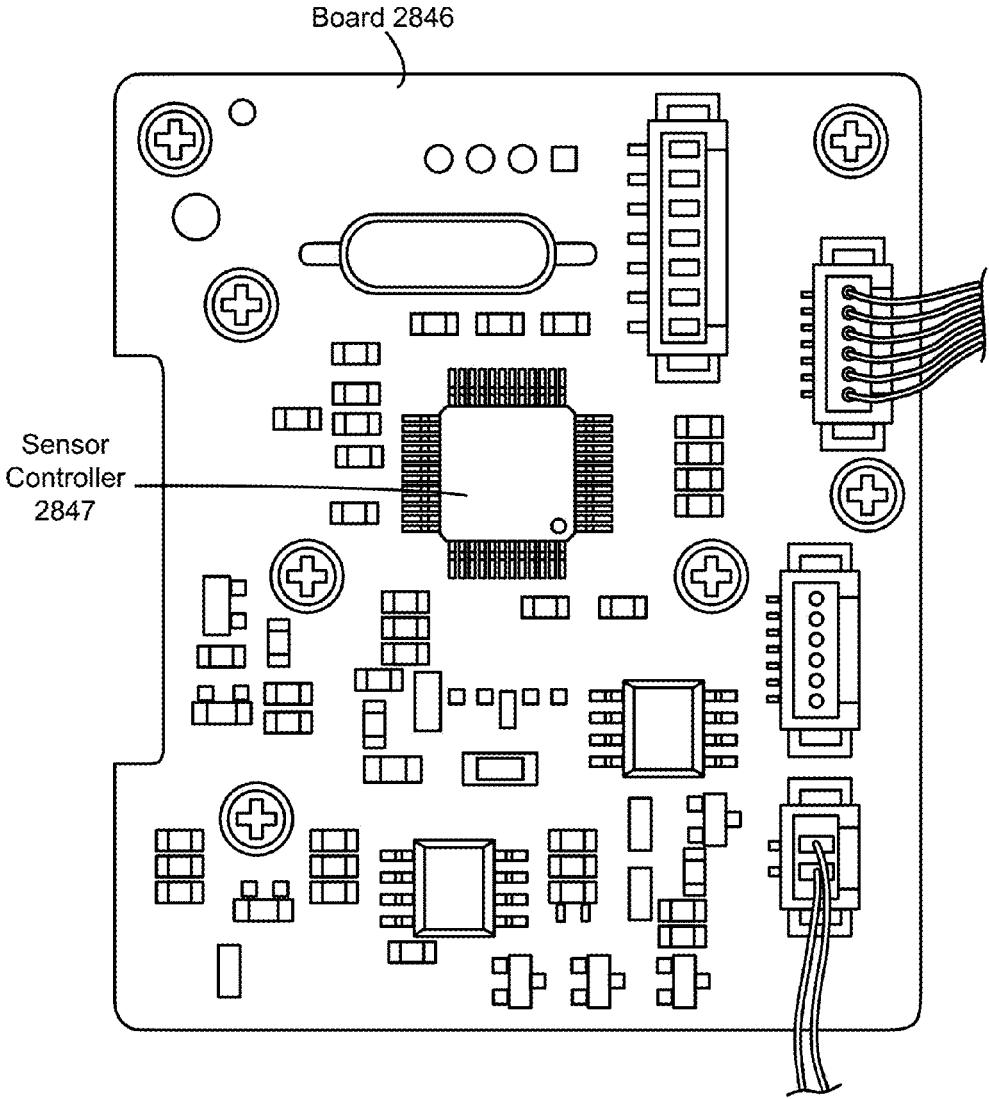


FIG. 28L

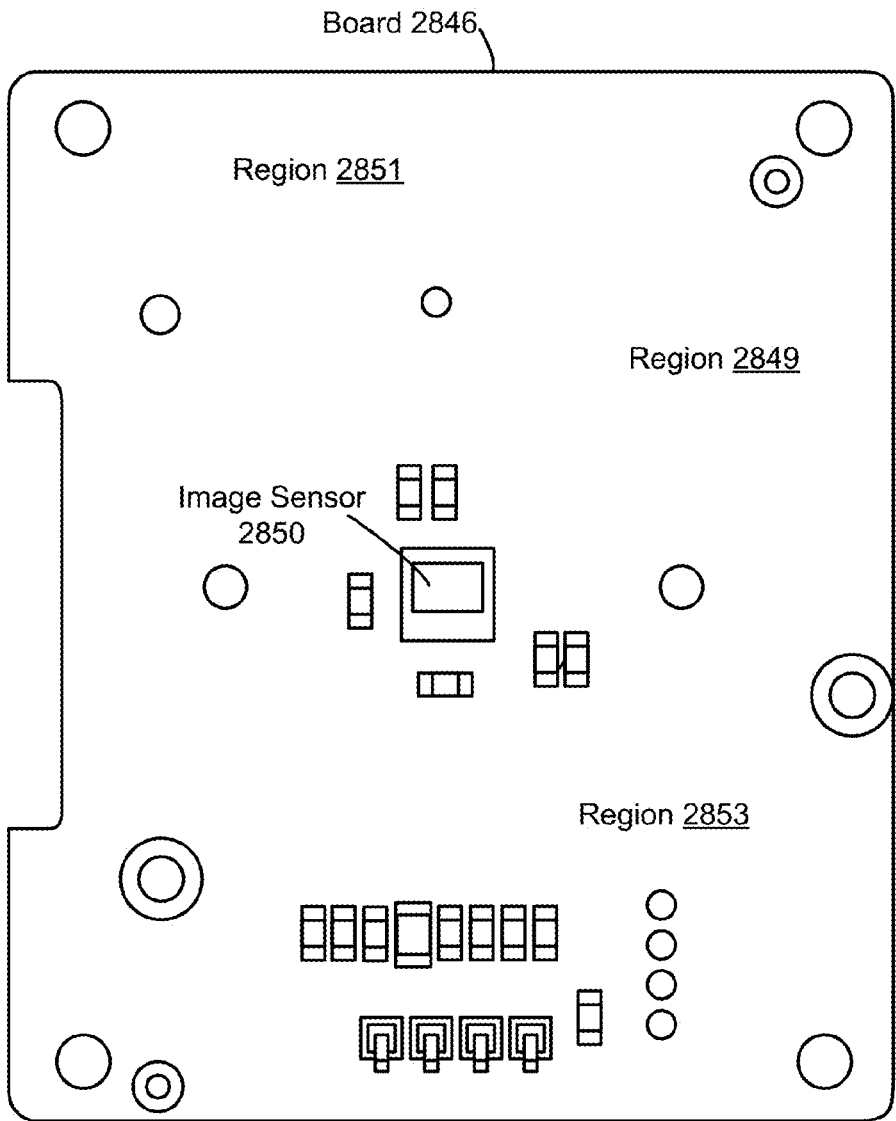


FIG. 28M

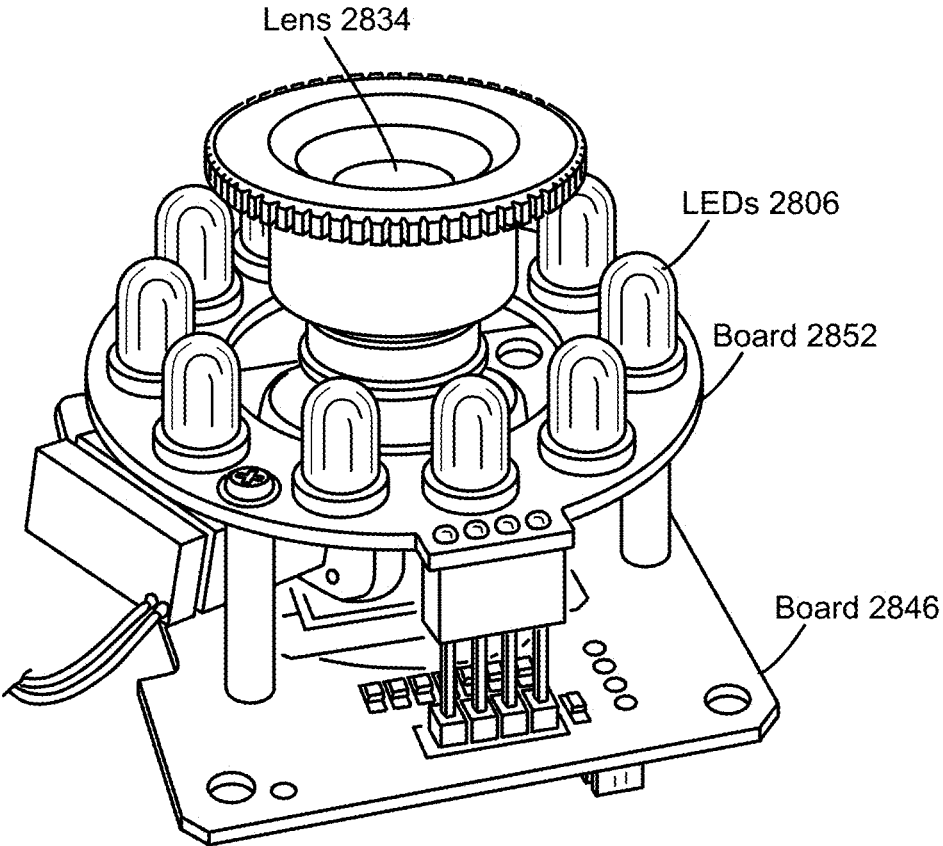


FIG. 28N

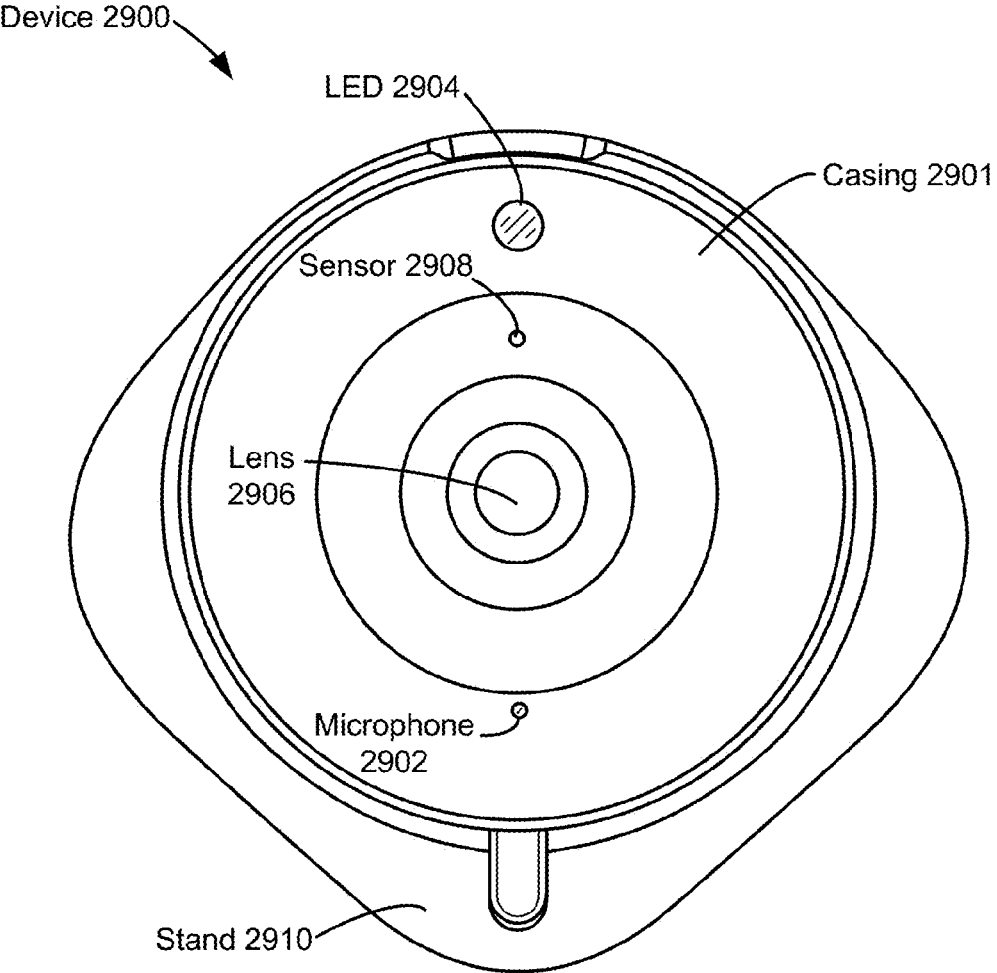


FIG. 29A

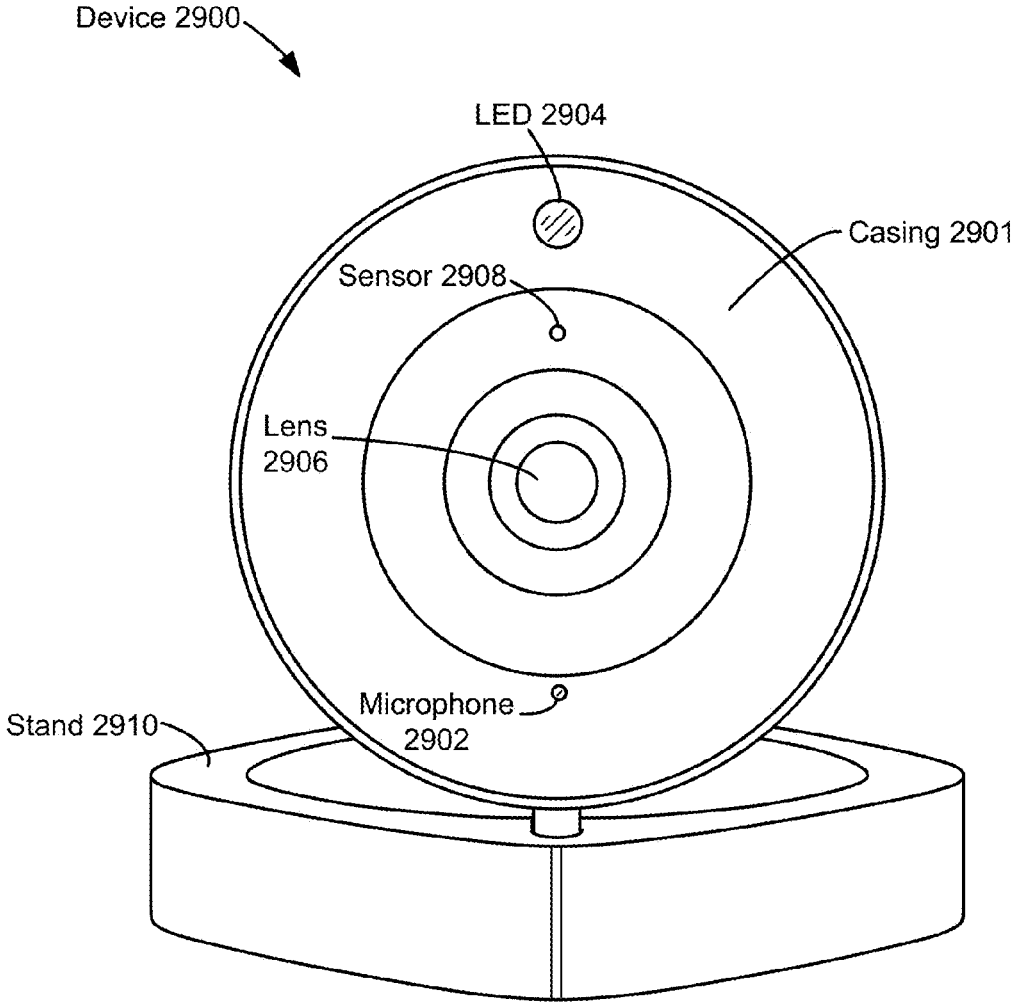


FIG. 29B

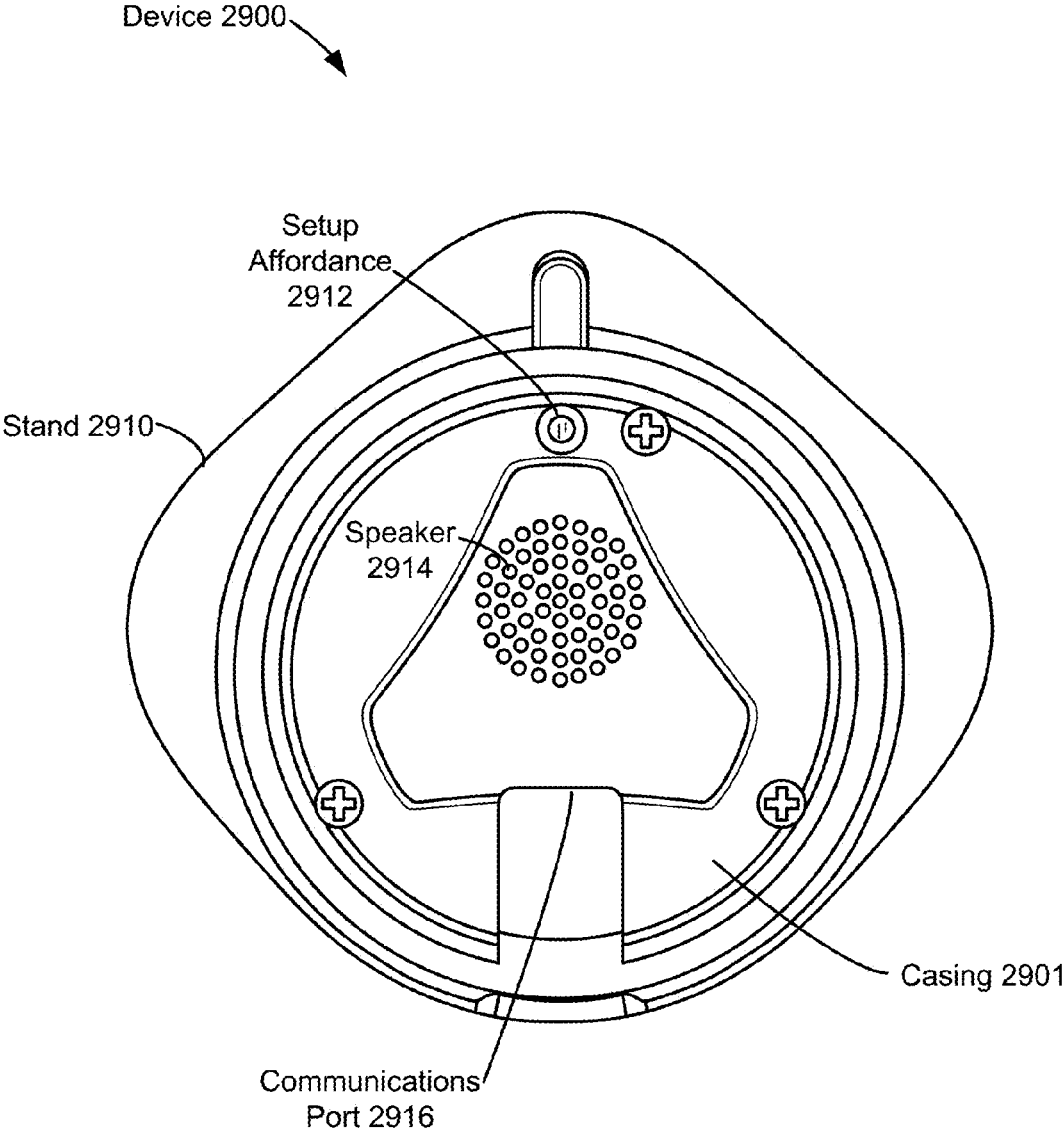


FIG. 29C

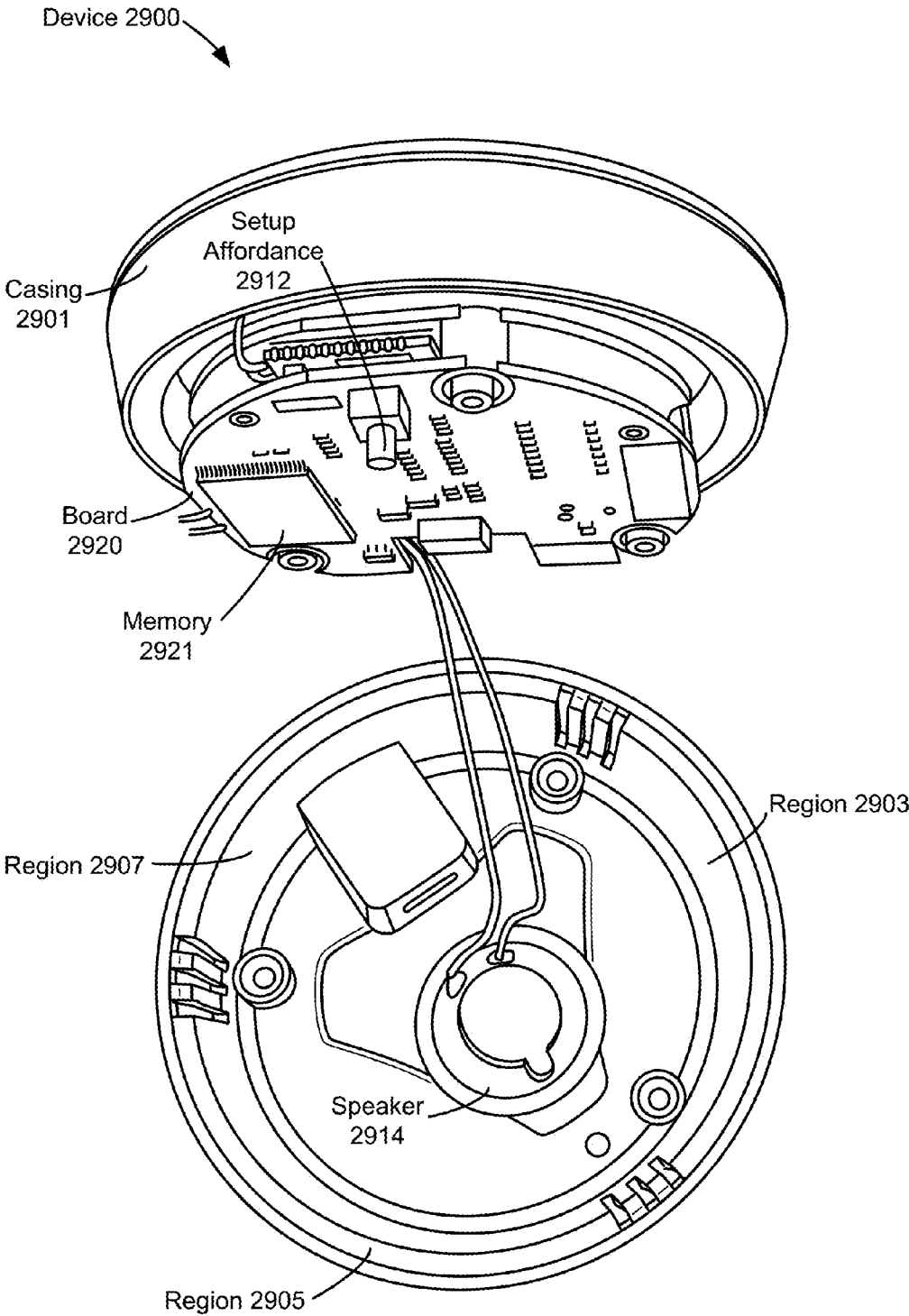


FIG. 29D

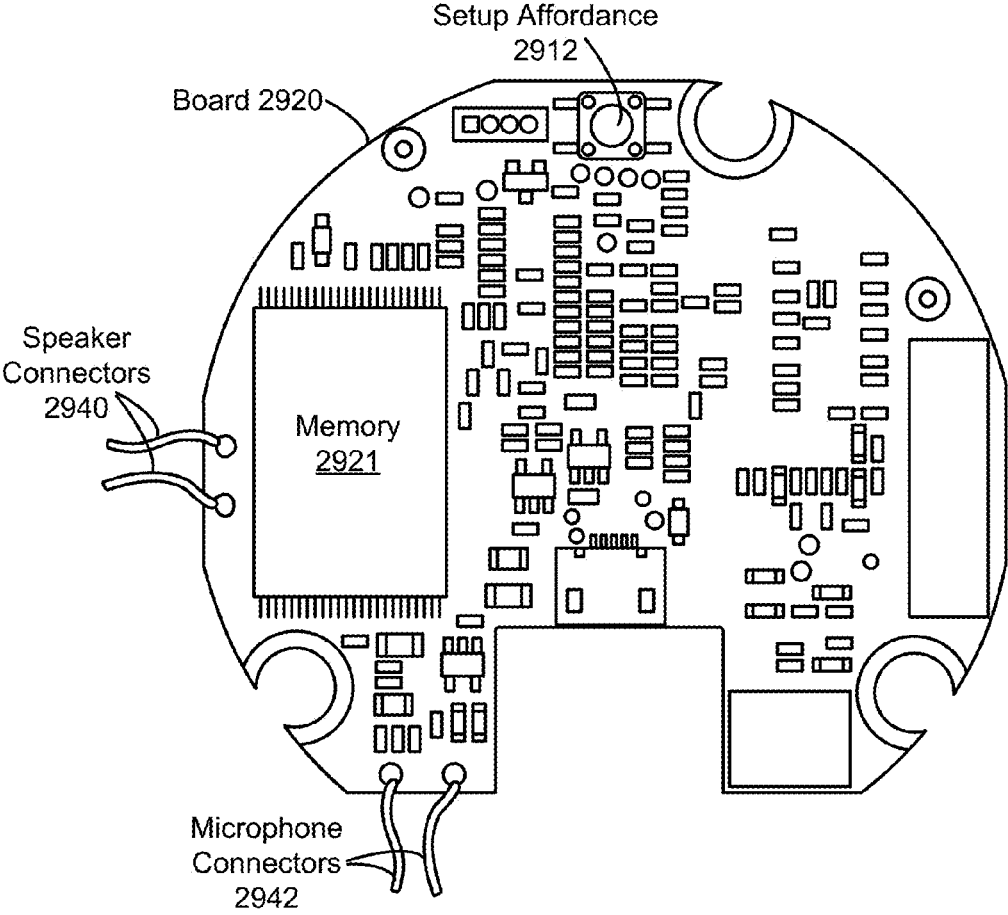


FIG. 29E



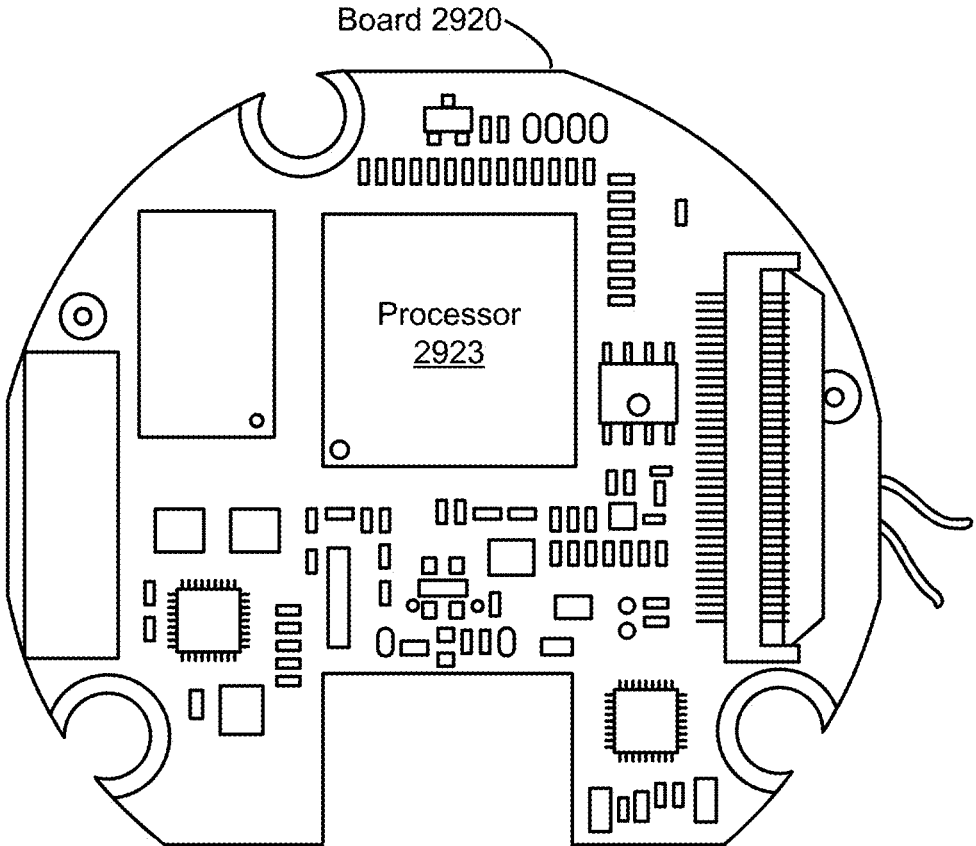


FIG. 29F

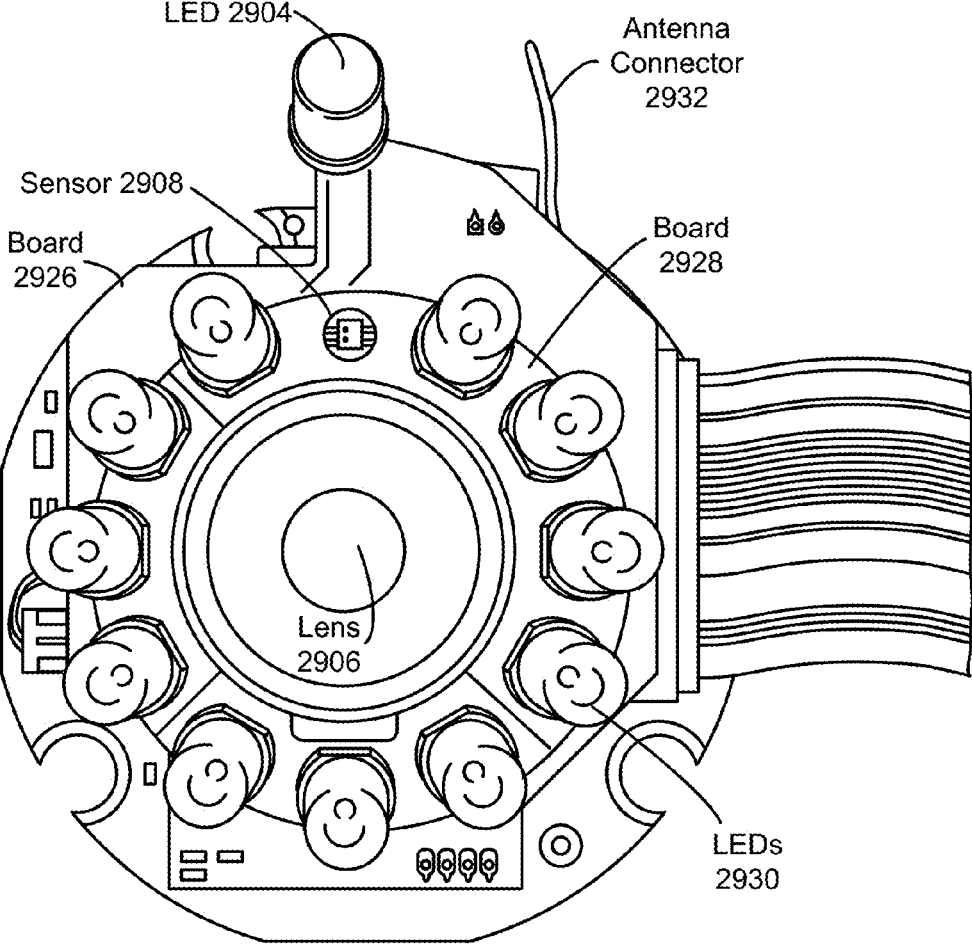


FIG. 29G

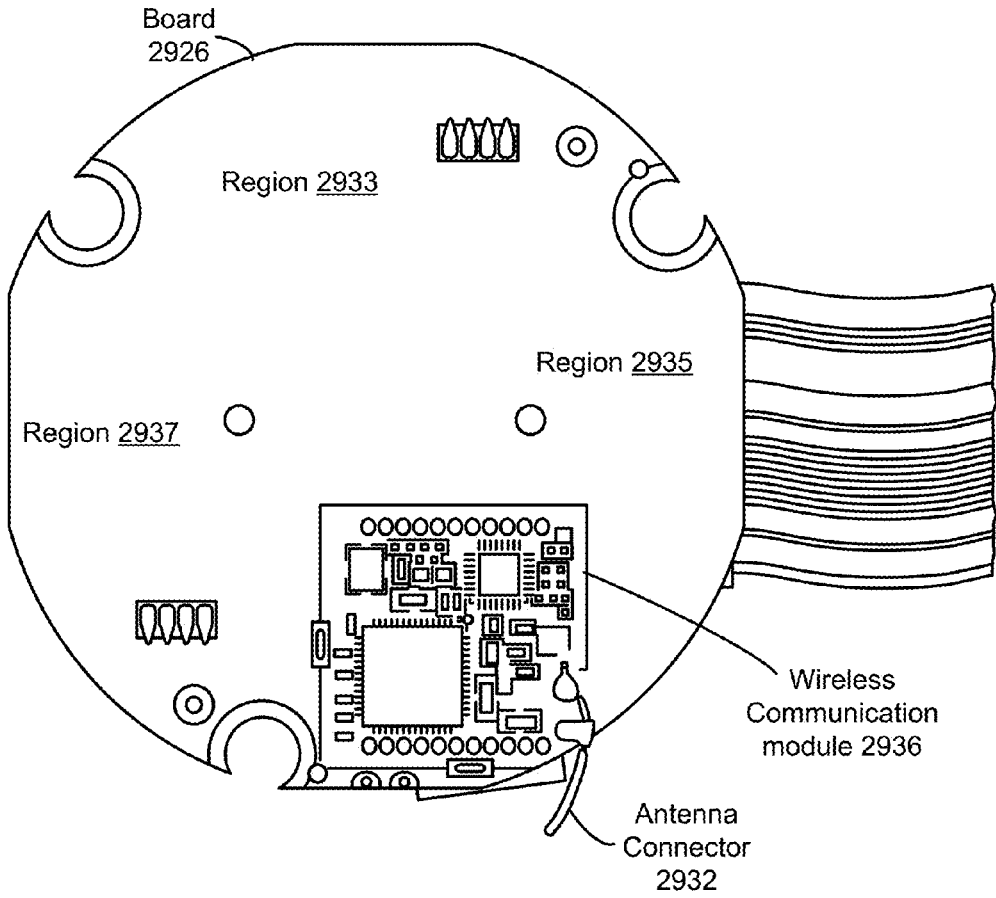


FIG. 29H

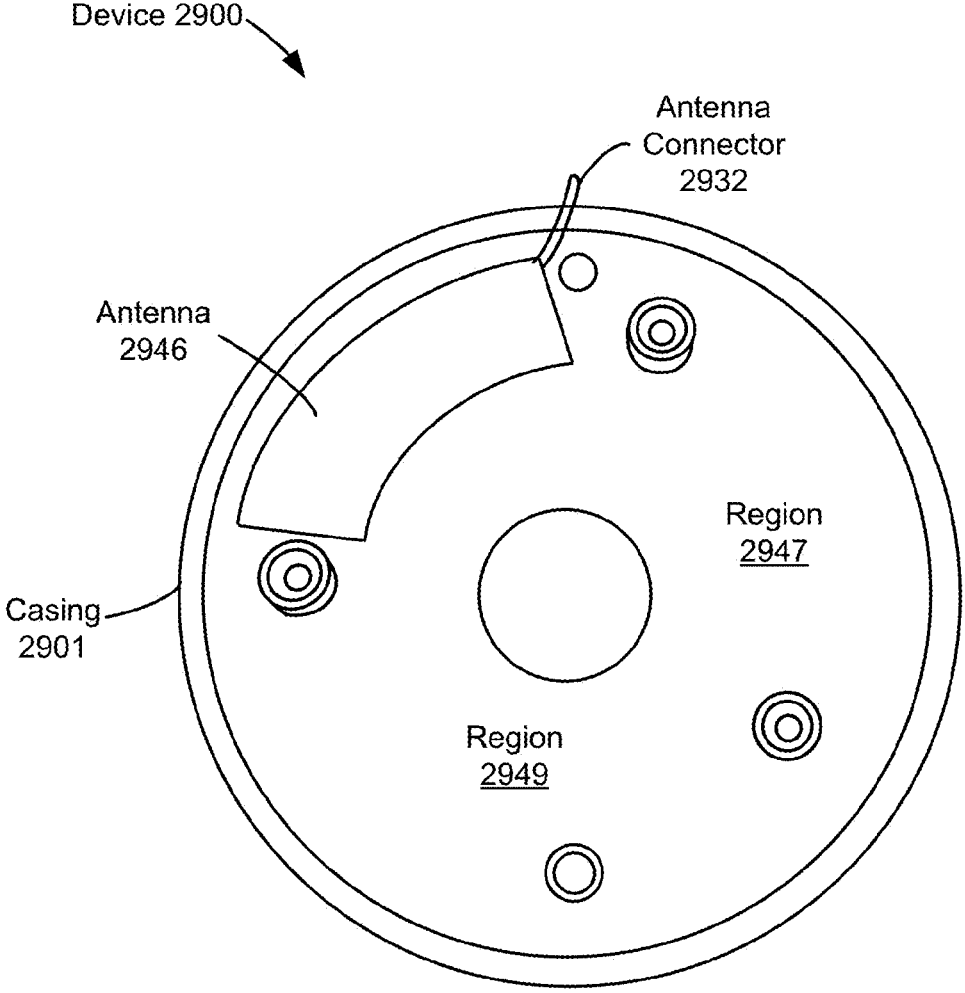


FIG. 29I

**SYSTEMS, METHODS, AND DEVICES FOR  
MANAGING COEXISTENCE OF MULTIPLE  
TRANSCIVER DEVICES BY OPTIMIZING  
COMPONENT LAYOUT**

**RELATED APPLICATIONS**

[0001] This application is a continuation of U.S. patent application Ser. No. 15/085,927, filed Mar. 30, 2016, entitled “Systems, Methods, and Devices for Managing Coexistence of Multiple Transceiver Devices by Optimizing Component Layout,” which is a continuation-in-part of U.S. patent application Ser. No. 14/616,302, filed Feb. 6, 2015, entitled “Systems and Methods for Processing Coexisting Signals for Rapid Response to User Input,” and a continuation-in-part of U.S. patent application Ser. No. 14/819,373 (issued as U.S. Pat. No. 9,396,633), filed Aug. 5, 2015, entitled “Systems, Methods, and Devices for Managing Coexistence of Multiple Transceiver Devices by Optimizing Component Layout,” which claims priority to U.S. Provisional Application No. 62/175,393, filed Jun. 14, 2015, entitled “Systems, Methods, and Devices for Managing Coexistence of Multiple Transceiver Devices by Optimizing Component Layout,” each of which is hereby incorporated by reference in its entirety.

[0002] This application is related to U.S. patent application Ser. No. 13/656,189 (issued as U.S. Pat. No. 9,234,668), filed Oct. 19, 2012, entitled “User-friendly, network connected learning thermostat and related systems and methods,” and U.S. patent application Ser. No. 13/835,439 (issued as U.S. Pat. No. 9,007,222), filed Mar. 15, 2013, entitled “Detector unit and sensing chamber therefor,” which are hereby incorporated by reference in their entirety.

**TECHNICAL FIELD**

[0003] This relates generally to computer technology, including but not limited to methods and systems for managing coexistence of multiple transceiver devices.

**BACKGROUND**

[0004] Devices in a smart home environment include a host of circuit components and interfaces for enabling communications with other systems, devices, and/or servers. For example, some smart devices include multiple radios as components of a single integrated circuit collocated within a compact area for receiving and transmitting signals to other devices and across networks. As a consequence of the close physical spacing of components within smart devices, combined with close proximity to nearby conductive materials and the fact that devices often share the same or close frequency bands in operation, device components typically exhibit poor isolation from transmissions of one another. In addition to poor communications performance, sensitive device components are also at risk of damage when their input power thresholds are exceeded due to poor isolation.

**SUMMARY**

[0005] Accordingly, there is a need for methods, apparatuses, and systems for managing coexistence of multiple transceivers in a device. By utilizing various component layout strategies within a device, using bypass circuitry, and/or using various control signals for prioritizing transmission access, the impact and harmful effects arising from poorly isolated transceivers in a device are reduced.

[0006] In accordance with some implementations, a camera assembly includes an enclosed housing having a rear surface, a front surface, and a periphery. Furthermore, the camera assembly includes a lens module located within the housing and configured to receive light via the front surface, and communication circuitry located within the housing and configured to wireless communicate over a plurality of different communication protocols. The camera assembly further includes a first antenna arranged at a first location on an inner surface of the periphery, the first antenna configured for communication over a first one of the communication protocols, and a second antenna arranged at a second location on the inner surface of the periphery, the second location being different than the first location, the second antenna configured for communication over a second one of the communication protocols.

[0007] Another aspect includes a communications apparatus including a first and second transceiver, and a first and second antenna. The communications apparatus further includes a front end module (FEM) coupled between the first transceiver and the first antenna, the front end module including an amplifier for amplifying signals received by the first antenna, and a bypass line. The FEM is configured to couple the first antenna to the first transceiver via the bypass line when the second transceiver is active and transmitting signals using the second antenna such that a signal received via the first antenna is not amplified by the amplifier prior to being passed to the first transceiver. Furthermore, the FEM is configured to couple the first antenna to the first transceiver via the amplifier when the second transceiver is not transmitting signals using the second antenna such that a signal received via the first antenna is amplified by the amplifier prior to being passed to the first transceiver.

[0008] In accordance with some implementations, a method for communicating via a plurality of transceivers includes coupling a first transceiver of a plurality of transceivers of an electronic device to a first antenna via an amplifier such that a signal received by the first antenna is amplified by the amplifier prior to being passed to the first transceiver, in accordance with detecting that a second transceiver of the plurality of transceivers is not transmitting signals via a second antenna coupled to the second transceiver. The method further includes coupling the first transceiver to the first antenna via a bypass line such that a signal received by the first antenna is not amplified by the amplifier prior to being passed to the first transceiver, in accordance with detecting that the second transceiver is transmitting signals via the second antenna.

[0009] In accordance with some implementations, a communications apparatus including a first and second transceiver, and a first and second antenna. The communications apparatus further includes a coupling means. The coupling means is configured to couple the first antenna to the first transceiver via the bypass line when the second transceiver is active and transmitting signals using the second antenna such that a signal received via the first antenna is not amplified by the amplifier prior to being passed to the first transceiver. Furthermore, the coupling means is configured to couple the first antenna to the first transceiver via the amplifier when the second transceiver is not transmitting signals using the second antenna such that a signal received via the first antenna is amplified by the amplifier prior to being passed to the first transceiver.

**[0010]** Another aspect includes a method for communicating via a plurality of transceivers, the method performed at a camera device comprising a plurality of distinct transceivers configured for communication over respective communication protocols, one or more processors, and memory storing instructions for execution by the one or more processors. The method includes communicating using a first transceiver of the plurality of transceivers, the first transceiver configured to transmit and receive, over a first one of the communication protocols, signals for configuring the camera device. Furthermore, the method includes communicating with one or more smart home devices using a second transceiver of the plurality of transceivers, the second transceiver configured to transmit and receive, over a second one of the communication protocols, signals comprising one or more of alerts, control signals and status information to and from the one or more smart home devices. Furthermore, the method includes communicating using a third transceiver of the plurality of transceivers, the third transceiver configured to transmit and receive, over a third one of the communication protocols, data corresponding to video captured by the camera device.

**[0011]** In accordance with some implementations, a camera device includes a first and second antenna, and a first, second, and third transceiver. The first transceiver is configured to transmit and receive, over a first one of a plurality of distinct communication protocols, signals for configuring the camera device. Furthermore, the second transceiver is configured to transmit and receive, over a second one of the plurality of distinct communication protocols, signals comprising one or more of alerts, control signals and status information to and from the one or more smart home devices. Moreover, the third transceiver is configured to transmit and receive, over a third one of the plurality of distinct communication protocols, data corresponding to video captured by the camera device, wherein the second transceiver is coupled to the first antenna, and the first and third transceivers are coupled to the second antenna.

**[0012]** Antenna performance is generally characterized by metrics such as impedance bandwidth, efficiency, directive gain, polarization, and radiation pattern. The same parameters are applicable for evaluating both transmitting and receiving operations, although the preferred values generally differ. Regarding impedance bandwidth, an antenna is generally a transducer between the characteristic impedance of a radio system (e.g., 50 ohms) and the impedance of free space. Thus, the antenna should comprise an acceptable impedance match over the frequency band(s) of operation. The antenna's performance bandwidth is generally proportional to the volume the antenna occupies, so very small antennas produce inadequate bandwidth in some instances.

**[0013]** Antennas may be omni-directional or directional. However, even omni-directional antennas generally have preferred directions where the radiated energy is greater than in one or more non-preferred directions. Efficient transfer of energy between two antennas includes optimizing the antenna's respective radiation patterns as well as their respective energy polarizations. However, many environmental factors affect an antenna's radiation pattern and/or polarization. For devices that have a preferred orientation, location, and/or position, the preferences may be taken into account to determine an optimal or sufficient radiation pattern.

**[0014]** Efficiency is another important performance parameter. Efficiency is a measure of what portion of the

power supplied to the antenna, including any reflection loss, is actually radiated by the antenna. As discussed previously, tightly integrated antennas are susceptible to interference and/or loss making them less efficient. For example, nearby component, such as grounded conductors and dielectric materials (e.g., a typical plastic housing), will constrain and/or absorb the near-fields of the antenna and cause significant losses. Energy loss may occur during both receive and transmit operations. However, the more efficient the antenna, the more it may interact with the local ground plane of the device.

**[0015]** Due to the interactions between an antenna and other components of a device, determining what type of antenna to use for a particular device includes considering characteristics of the entire device. Conductive components of the device likely have the largest influence on an antenna, but non-conductive components also an effect on the antenna's performance. Antenna performance is also affected by electrical noise generated by the circuitry of the device and result in poor or intermittent performance; particularly if the circuitry is located near the antenna.

**[0016]** Wireless devices often have multiple transceivers operating in various bands, such as Wi-Fi (optionally using Multiple Input Multiple Output), Bluetooth, ZigBee, GPS, etc. Each transceiver has an associated antenna, and signals and/or noise from one antenna creates interference with other antennas. Generally it is preferable to maximize the distance between the antennas so as to minimize the potential for interference. However, in some small devices, antennas must be placed near one another.

#### BRIEF DESCRIPTION OF THE DRAWINGS

**[0017]** For a better understanding of the various described implementations, reference should be made to the Description of Implementations below, in conjunction with the following drawings in which like reference numerals refer to corresponding parts throughout the figures.

**[0018]** FIG. 1 is an example smart home environment, in accordance with some implementations.

**[0019]** FIG. 2 is a block diagram illustrating an example network architecture that includes a smart home network, in accordance with some implementations.

**[0020]** FIG. 3 illustrates a network-level view of an extensible devices and services platform with which the smart home environment of FIG. 1 is integrated, in accordance with some implementations.

**[0021]** FIG. 4 illustrates an abstracted functional view of the extensible devices and services platform of FIG. 3, with reference to a processing engine as well as devices of the smart home environment, in accordance with some implementations.

**[0022]** FIG. 5 is a representative operating environment in which a hub device server system interacts with client devices and hub devices communicatively coupled to local smart devices, in accordance with some implementations.

**[0023]** FIG. 6 is a block diagram illustrating a representative hub device, in accordance with some implementations.

**[0024]** FIG. 7 is a block diagram illustrating a representative hub server system, in accordance with some implementations.

**[0025]** FIG. 8 is a block diagram illustrating a representative client device associated with a user account, in accordance with some implementations.

[0026] FIG. 9 is a block diagram illustrating a representative smart device, in accordance with some implementations.

[0027] FIG. 10 is a block diagram illustrating a representative smart home provider server system, in accordance with some implementations.

[0028] FIGS. 11A-11M illustrate various assembly views of a camera device 118, in accordance with some implementations.

[0029] FIGS. 12A-12C illustrate various component views of a thermostat, in accordance with some implementations.

[0030] FIGS. 13A-13D illustrate various component views of a hazard detector, in accordance with some implementations.

[0031] FIG. 14 illustrates a block diagram of a communications module of a smart device utilizing a bypass coexistence technique, in accordance with some implementations.

[0032] FIGS. 15A-15G illustrate a coexistence scheme for a smart device having multiple radios in smart home environment, in accordance with some implementations. FIG. 15A illustrates a representative device having multiple radios in a smart home environment, in accordance with some implementations. FIG. 15B illustrates an example of an internal arbitration scheme between transceivers combined in a single device, in accordance with some implementations. FIG. 15C illustrates a table of example control signal assignments, in accordance with some implementations. FIGS. 15D-1 and 15D-2 illustrate a signal timing diagram and timing chart for a normal mode of operation for a coexistence scheme, in accordance with some implementations. FIGS. 15E-1 and 15E-2 illustrate a signal timing diagram and timing chart for a mode of operation in a coexistence scheme in which a request grant is revoked based on predefined performance requirements, in accordance with some implementations. FIGS. 15F-1 and 15F-2 illustrate a signal timing diagram and timing chart for a mode of operation for a coexistence scheme utilizing beacon protection, in accordance with some implementations. FIG. 15F-3 illustrates an example of a signal timing diagram with beacon skipping, in accordance with some implementations. FIGS. 15G-1 and 15G-2 illustrate a signal timing diagram and timing chart for an “alarming” mode of operation for a coexistence scheme, in accordance with some implementations.

[0033] FIG. 16 shows an illustrative co-existence circuit for managing operations of three communications circuits, in accordance with some implementations.

[0034] FIGS. 17A-17B show priority cases for Wi-Fi circuitry, in accordance with some implementations.

[0035] FIGS. 18A-D shows different illustrative 6LoWPAN priority use cases, in accordance with some implementations.

[0036] FIGS. 19A-19B show illustrative timing diagrams where Wi-Fi circuitry is OFF, in accordance with some implementations.

[0037] FIG. 20 shows an illustrative timing diagram showing how the BLE circuitry attempts to communicate with a personal device during the idle portion of a wake packet being transmitted by 6LoWPAN circuitry during a NCCA period, in accordance with some implementations.

[0038] FIG. 21 shows illustrative timing diagrams of exemplary BLE advertise, connect, and data transfer activity during BLE transmissions, in accordance with some implementations.

[0039] FIG. 22 is a flow diagram illustrating a method of coexistence using bypass circuitry, in accordance with some implementations.

[0040] FIGS. 23A-23F are flow diagrams illustrating methods of using control signals in a coexistence scheme, in accordance with some implementations.

[0041] FIGS. 24A-24D illustrate various types of antennas for use with the various devices disclosed herein.

[0042] FIGS. 25A-25F illustrate various assembly views of a camera device, in accordance with some implementations.

[0043] FIGS. 26A-26J illustrate various assembly views of a camera device, in accordance with some implementations.

[0044] FIGS. 27A-27I illustrate various assembly views of a camera device, in accordance with some implementations.

[0045] FIGS. 28A-28N illustrate various assembly views of a camera device, in accordance with some implementations.

[0046] FIGS. 29A-29I illustrate various assembly views of a camera device, in accordance with some implementations.

[0047] Like reference numerals refer to corresponding parts throughout the several views of the drawings.

#### DESCRIPTION OF IMPLEMENTATIONS

[0048] Reference will now be made in detail to implementations, examples of which are illustrated in the accompanying drawings. In the following detailed description, numerous specific details are set forth in order to provide a thorough understanding of the various described implementations. However, it will be apparent to one of ordinary skill in the art that the various described implementations may be practiced without these specific details. In other instances, well-known methods, procedures, components, circuits, and networks have not been described in detail so as not to unnecessarily obscure aspects of the implementations.

[0049] FIG. 1 is an example smart home environment 100 in accordance with some implementations. Smart home environment 100 includes a structure 150 (e.g., a house, office building, garage, or mobile home) with various integrated devices. It will be appreciated that devices may also be integrated into a smart home environment 100 that does not include an entire structure 150, such as an apartment, condominium, or office space. Further, the smart home environment 100 may control and/or be coupled to devices outside of the actual structure 150. Indeed, several devices in the smart home environment 100 need not be physically within the structure 150. For example, a device controlling a pool heater 114 or irrigation system 116 may be located outside of the structure 150.

[0050] The depicted structure 150 includes a plurality of rooms 152, separated at least partly from each other via walls 154. The walls 154 may include interior walls or exterior walls. Each room may further include a floor 156 and a ceiling 158. Devices may be mounted on, integrated with and/or supported by a wall 154, floor 156 or ceiling 158.

[0051] In some implementations, the integrated devices of the smart home environment 100 include intelligent, multi-sensing, network-connected devices that integrate seam-

lessly with each other in a smart home network (e.g., 202 FIG. 2) and/or with a central server or a cloud-computing system to provide a variety of useful smart home functions. The smart home environment 100 may include one or more intelligent, multi-sensing, network-connected thermostats 102 (hereinafter referred to as “smart thermostats 102”), one or more intelligent, network-connected, multi-sensing hazard detection units 104 (hereinafter referred to as “smart hazard detectors 104”), one or more intelligent, multi-sensing, network-connected entryway interface devices 106 and 120 (hereinafter referred to as “smart doorbells 106” and “smart door locks 120”), and one or more intelligent, multi-sensing, network-connected alarm systems 122 (hereinafter referred to as “smart alarm systems 122”).

[0052] In some implementations, the one or more smart thermostats 102 detect ambient climate characteristics (e.g., temperature and/or humidity) and control a HVAC system 103 accordingly. For example, a respective smart thermostat 102 includes an ambient temperature sensor.

[0053] The one or more smart hazard detectors 104 may include thermal radiation sensors directed at respective heat sources (e.g., a stove, oven, other appliances, a fireplace, etc.). For example, a smart hazard detector 104 in a kitchen 153 includes a thermal radiation sensor directed at a stove/oven 112. A thermal radiation sensor may determine the temperature of the respective heat source (or a portion thereof) at which it is directed and may provide corresponding blackbody radiation data as output.

[0054] The smart doorbell 106 and/or the smart door lock 120 may detect a person’s approach to or departure from a location (e.g., an outer door), control doorbell/door locking functionality (e.g., receive user inputs from a portable electronic device 166-1 to actuate bolt of the smart door lock 120), announce a person’s approach or departure via audio or visual means, and/or control settings on a security system (e.g., to activate or deactivate the security system when occupants go and come).

[0055] The smart alarm system 122 may detect the presence of an individual within close proximity (e.g., using built-in IR sensors), sound an alarm (e.g., through a built-in speaker, or by sending commands to one or more external speakers), and send notifications to entities or users within/outside of the smart home network 100. In some implementations, the smart alarm system 122 also includes one or more input devices or sensors (e.g., keypad, biometric scanner, NFC transceiver, microphone) for verifying the identity of a user, and one or more output devices (e.g., display, speaker). In some implementations, the smart alarm system 122 may also be set to an “armed” mode, such that detection of a trigger condition or event causes the alarm to be sounded unless a disarming action is performed.

[0056] In some implementations, the smart home environment 100 includes one or more intelligent, multi-sensing, network-connected wall switches 108 (hereinafter referred to as “smart wall switches 108”), along with one or more intelligent, multi-sensing, network-connected wall plug interfaces 110 (hereinafter referred to as “smart wall plugs 110”). The smart wall switches 108 may detect ambient lighting conditions, detect room-occupancy states, and control a power and/or dim state of one or more lights. In some instances, smart wall switches 108 may also control a power state or speed of a fan, such as a ceiling fan. The smart wall plugs 110 may detect occupancy of a room or enclosure and

control supply of power to one or more wall plugs (e.g., such that power is not supplied to the plug if nobody is at home).

[0057] In some implementations, the smart home environment 100 of FIG. 1 includes a plurality of intelligent, multi-sensing, network-connected appliances 112 (hereinafter referred to as “smart appliances 112”), such as refrigerators, stoves, ovens, televisions, washers, dryers, lights, stereos, intercom systems, garage-door openers, floor fans, ceiling fans, wall air conditioners, pool heaters, irrigation systems, security systems, space heaters, window AC units, motorized duct vents, and so forth. In some implementations, when plugged in, an appliance may announce itself to the smart home network, such as by indicating what type of appliance it is, and it may automatically integrate with the controls of the smart home. Such communication by the appliance to the smart home may be facilitated by either a wired or wireless communication protocol. The smart home may also include a variety of non-communicating legacy appliances 140, such as old conventional washer/dryers, refrigerators, and the like, which may be controlled by smart wall plugs 110. The smart home environment 100 may further include a variety of partially communicating legacy appliances 142, such as infrared (“IR”) controlled wall air conditioners or other IR-controlled devices, which may be controlled by IR signals provided by the smart hazard detectors 104 or the smart wall switches 108.

[0058] In some implementations, the smart home environment 100 includes one or more network-connected cameras 118 that are configured to provide video monitoring and security in the smart home environment 100. The cameras 118 may be used to determine occupancy of the structure 150 and/or particular rooms 152 in the structure 150, and thus may act as occupancy sensors. For example, video captured by the cameras 118 may be processed to identify the presence of an occupant in the structure 150 (e.g., in a particular room 152). Specific individuals may be identified based, for example, on their appearance (e.g., height, face) and/or movement (e.g., their walk/gait). Cameras 118 may additionally include one or more sensors (e.g., IR sensors, motion detectors), input devices (e.g., microphone for capturing audio), and output devices (e.g., speaker for outputting audio).

[0059] The smart home environment 100 may additionally or alternatively include one or more other occupancy sensors (e.g., the smart doorbell 106, smart door locks 120, touch screens, IR sensors, microphones, ambient light sensors, motion detectors, smart nightlights 170, etc.). In some implementations, the smart home environment 100 includes radio-frequency identification (RFID) readers (e.g., in each room 152 or a portion thereof) that determine occupancy based on RFID tags located on or embedded in occupants. For example, RFID readers may be integrated into the smart hazard detectors 104.

[0060] The smart home environment 100 may also include communication with devices outside of the physical home but within a proximate geographical range of the home. For example, the smart home environment 100 may include a pool heater monitor 114 that communicates a current pool temperature to other devices within the smart home environment 100 and/or receives commands for controlling the pool temperature. Similarly, the smart home environment 100 may include an irrigation monitor 116 that communicates information regarding irrigation systems within the



smart home environment **100** and/or receives control information for controlling such irrigation systems.

**[0061]** By virtue of network connectivity, one or more of the smart home devices of FIG. 1 may further allow a user to interact with the device even if the user is not proximate to the device. For example, a user may communicate with a device using a computer (e.g., a desktop computer, laptop computer, or tablet) or other portable electronic device **166** (e.g., a mobile phone, such as a smart phone). A webpage or application may be configured to receive communications from the user and control the device based on the communications and/or to present information about the device's operation to the user. For example, the user may view a current set point temperature for a device (e.g., a stove) and adjust it using a computer. The user may be in the structure during this remote communication or outside the structure.

**[0062]** As discussed above, users may control smart devices in the smart home environment **100** using a network-connected computer or portable electronic device **166**. In some examples, some or all of the occupants (e.g., individuals who live in the home) may register their device **166** with the smart home environment **100**. Such registration may be made at a central server to authenticate the occupant and/or the device as being associated with the home and to give permission to the occupant to use the device to control the smart devices in the home. An occupant may use their registered device **166** to remotely control the smart devices of the home, such as when the occupant is at work or on vacation. The occupant may also use their registered device to control the smart devices when the occupant is actually located inside the home, such as when the occupant is sitting on a couch inside the home. It should be appreciated that instead of or in addition to registering devices **166**, the smart home environment **100** may make inferences about which individuals live in the home and are therefore occupants and which devices **166** are associated with those individuals. As such, the smart home environment may "learn" who is an occupant and permit the devices **166** associated with those individuals to control the smart devices of the home.

**[0063]** In some implementations, in addition to containing processing and sensing capabilities, devices **102**, **104**, **106**, **108**, **110**, **112**, **114**, **116**, **118**, **120**, and/or **122** (collectively referred to as "the smart devices") are capable of data communications and information sharing with other smart devices, a central server or cloud-computing system, and/or other devices that are network-connected. Data communications may be carried out using any of a variety of custom or standard wireless protocols (e.g., IEEE 802.15.4, Wi-Fi, ZigBee, 6LoWPAN, Thread, Z-Wave, Bluetooth Smart, ISA100.11a, WirelessHART, MiWi, etc.) and/or any of a variety of custom or standard wired protocols (e.g., Ethernet, HomePlug, etc.), or any other suitable communication protocol, including communication protocols not yet developed as of the filing date of this document.

**[0064]** In some implementations, the smart devices serve as wireless or wired repeaters. In some implementations, a first one of the smart devices communicates with a second one of the smart devices via a wireless router. The smart devices may further communicate with each other via a connection (e.g., network interface **160**) to a network, such as the Internet **162**. Through the Internet **162**, the smart devices may communicate with a smart home provider server system **164** (also called a central server system and/or a cloud-computing system herein). The smart home provider

server system **164** may be associated with a manufacturer, support entity, or service provider associated with the smart device(s). In some implementations, a user is able to contact customer support using a smart device itself rather than needing to use other communication means, such as a telephone or Internet-connected computer. In some implementations, software updates are automatically sent from the smart home provider server system **164** to smart devices (e.g., when available, when purchased, or at routine intervals).

**[0065]** In some implementations, the network interface **160** includes a conventional network device (e.g., a router), and the smart home environment **100** of FIG. 1 includes a hub device **180** that is communicatively coupled to the network(s) **162** directly or via the network interface **160**. The hub device **180** is further communicatively coupled to one or more of the above intelligent, multi-sensing, network-connected devices (e.g., smart devices of the smart home environment **100**). Each of these smart devices optionally communicates with the hub device **180** using one or more radio communication networks available at least in the smart home environment **100** (e.g., ZigBee, Z-Wave, Insteon, Bluetooth, Wi-Fi and other radio communication networks). In some implementations, the hub device **180** and devices coupled with/to the hub device can be controlled and/or interacted with via an application running on a smart phone, household controller, laptop, tablet computer, game console or similar electronic device. In some implementations, a user of such controller application can view status of the hub device or coupled smart devices, configure the hub device to interoperate with smart devices newly introduced to the home network, commission new smart devices, and adjust or view settings of connected smart devices, etc. In some implementations the hub device extends capabilities of low capability smart device to match capabilities of the highly capable smart devices of the same type, integrates functionality of multiple different device types—even across different communication protocols, and is configured to streamline adding of new devices and commissioning of the hub device.

**[0066]** It is to be appreciated that "smart home environments" may refer to smart environments for homes such as a single-family house, but the scope of the present teachings is not so limited. The present teachings are also applicable, without limitation, to duplexes, townhomes, multi-unit apartment buildings, hotels, retail stores, office buildings, industrial buildings, and more generally any living space or work space.

**[0067]** It is also to be appreciated that while the terms user, customer, installer, homeowner, occupant, guest, tenant, landlord, repair person, and the like may be used to refer to the person or persons acting in the context of some particularly situations described herein, these references do not limit the scope of the present teachings with respect to the person or persons who are performing such actions. Thus, for example, the terms user, customer, purchaser, installer, subscriber, and homeowner may often refer to the same person in the case of a single-family residential dwelling, because the head of the household is often the person who makes the purchasing decision, buys the unit, and installs and configures the unit, and is also one of the users of the unit. However, in other scenarios, such as a landlord-tenant environment, the customer may be the landlord with respect to purchasing the unit, the installer may be a local apartment

supervisor, a first user may be the tenant, and a second user may again be the landlord with respect to remote control functionality. Importantly, while the identity of the person performing the action may be germane to a particular advantage provided by one or more of the implementations, such identity should not be construed in the descriptions that follow as necessarily limiting the scope of the present teachings to those particular individuals having those particular identities.

**[0068]** FIG. 2 is a block diagram illustrating an example network architecture 200 that includes a smart home network 202 in accordance with some implementations. In some implementations, the smart devices 204 in the smart home environment 100 (e.g., devices 102, 104, 106, 108, 110, 112, 114, 116, 118, 120, and/or 122) combine with the hub device 180 to create a mesh network in smart home network 202. In some implementations, one or more smart devices 204 in the smart home network 202 operate as a smart home controller. Additionally and/or alternatively, hub device 180 operates as the smart home controller. In some implementations, a smart home controller has more computing power than other smart devices. In some implementations, a smart home controller processes inputs (e.g., from smart devices 204, electronic device 166, and/or smart home provider server system 164) and sends commands (e.g., to smart devices 204 in the smart home network 202) to control operation of the smart home environment 100. In some implementations, some of the smart devices 204 in the smart home network 202 (e.g., in the mesh network) are “spokesman” nodes (e.g., 204-1) and others are “low-powered” nodes (e.g., 204-9). Some of the smart devices in the smart home environment 100 are battery powered, while others have a regular and reliable power source, such as by connecting to wiring (e.g., to 120V line voltage wires) behind the walls 154 of the smart home environment. The smart devices that have a regular and reliable power source are referred to as “spokesman” nodes. These nodes are typically equipped with the capability of using a wireless protocol to facilitate bidirectional communication with a variety of other devices in the smart home environment 100, as well as with the smart home provider server system 164. In some implementations, one or more “spokesman” nodes operate as a smart home controller. On the other hand, the devices that are battery powered are the “low-power” nodes. These nodes tend to be smaller than spokesman nodes and typically only communicate using wireless protocols that require very little power, such as Zigbee, 6LoWPAN, etc.

**[0069]** In some implementations, some low-power nodes are incapable of bidirectional communication. These low-power nodes send messages, but they are unable to “listen”. Thus, other devices in the smart home environment 100, such as the spokesman nodes, cannot send information to these low-power nodes.

**[0070]** In some implementations, some low-power nodes are capable of only a limited bidirectional communication. For example, other devices are able to communicate with the low-power nodes only during a certain time period.

**[0071]** As described, in some implementations, the smart devices serve as low-power and spokesman nodes to create a mesh network in the smart home environment 100. In some implementations, individual low-power nodes in the smart home environment regularly send out messages regarding what they are sensing, and the other low-powered nodes in the smart home environment—in addition to send-

ing out their own messages—forward the messages, thereby causing the messages to travel from node to node (i.e., device to device) throughout the smart home network 202. In some implementations, the spokesman nodes in the smart home network 202, which are able to communicate using a relatively high-power communication protocol, such as IEEE 802.11, are able to switch to a relatively low-power communication protocol, such as IEEE 802.15.4, to receive these messages, translate the messages to other communication protocols, and send the translated messages to other spokesman nodes and/or the smart home provider server system 164 (using, e.g., the relatively high-power communication protocol). Thus, the low-powered nodes using low-power communication protocols are able to send and/or receive messages across the entire smart home network 202, as well as over the Internet 162 to the smart home provider server system 164. In some implementations, the mesh network enables the smart home provider server system 164 to regularly receive data from most or all of the smart devices in the home, make inferences based on the data, facilitate state synchronization across devices within and outside of the smart home network 202, and send commands to one or more of the smart devices to perform tasks in the smart home environment.

**[0072]** As described, the spokesman nodes and some of the low-powered nodes are capable of “listening.” Accordingly, users, other devices, and/or the smart home provider server system 164 may communicate control commands to the low-powered nodes. For example, a user may use the electronic device 166 (e.g., a smart phone) to send commands over the Internet to the smart home provider server system 164, which then relays the commands to one or more spokesman nodes in the smart home network 202. The spokesman nodes may use a low-power protocol to communicate the commands to the low-power nodes throughout the smart home network 202, as well as to other spokesman nodes that did not receive the commands directly from the smart home provider server system 164.

**[0073]** In some implementations, a smart nightlight 170 (FIG. 1), which is an example of a smart device 204, is a low-power node. In addition to housing a light source, the smart nightlight 170 houses an occupancy sensor, such as an ultrasonic or passive IR sensor, and an ambient light sensor, such as a photo resistor or a single-pixel sensor that measures light in the room. In some implementations, the smart nightlight 170 is configured to activate the light source when its ambient light sensor detects that the room is dark and when its occupancy sensor detects that someone is in the room. In other implementations, the smart nightlight 170 is simply configured to activate the light source when its ambient light sensor detects that the room is dark. Further, in some implementations, the smart nightlight 170 includes a low-power wireless communication chip (e.g., a ZigBee chip) that regularly sends out messages regarding the occupancy of the room and the amount of light in the room, including instantaneous messages coincident with the occupancy sensor detecting the presence of a person in the room. As mentioned above, these messages may be sent wirelessly (e.g., using the mesh network) from node to node (i.e., smart device to smart device) within the smart home network 202 as well as over the Internet 162 to the smart home provider server system 164.

**[0074]** Other examples of low-power nodes include battery-operated versions of the smart hazard detectors 104.

These smart hazard detectors **104** are often located in an area without access to constant and reliable power and may include any number and type of sensors, such as smoke/fire/heat sensors (e.g., thermal radiation sensors), carbon monoxide/dioxide sensors, occupancy/motion sensors, ambient light sensors, ambient temperature sensors, humidity sensors, and the like. Furthermore, smart hazard detectors **104** may send messages that correspond to each of the respective sensors to the other devices and/or the smart home provider server system **164**, such as by using the mesh network as described above.

**[0075]** Examples of spokesman nodes include smart doorbells **106**, smart thermostats **102**, smart wall switches **108**, and smart wall plugs **110**. These devices are often located near and connected to a reliable power source, and therefore may include more power-consuming components, such as one or more communication chips capable of bidirectional communication in a variety of protocols.

**[0076]** In some implementations, the smart home environment **100** includes service robots **168** (FIG. 1) that are configured to carry out, in an autonomous manner, any of a variety of household tasks.

**[0077]** As explained above with reference to FIG. 1, in some implementations, the smart home environment **100** of FIG. 1 includes a hub device **180** that is communicatively coupled to the network(s) **162** directly or via the network interface **160**. The hub device **180** is further communicatively coupled to one or more of the smart devices using a radio communication network that is available at least in the smart home environment **100**. Communication protocols used by the radio communication network include, but are not limited to, ZigBee, Z-Wave, Insteon, EuOcean, Thread, OSIAN, Bluetooth Low Energy and the like. In some implementations, the hub device **180** not only converts the data received from each smart device to meet the data format requirements of the network interface **160** or the network(s) **162**, but also converts information received from the network interface **160** or the network(s) **162** to meet the data format requirements of the respective communication protocol associated with a targeted smart device. In some implementations, in addition to data format conversion, the hub device **180** further processes the data received from the smart devices or information received from the network interface **160** or the network(s) **162** preliminary. For example, the hub device **180** can integrate inputs from multiple sensors/connected devices (including sensors/devices of the same and/or different types), perform higher level processing on those inputs—e.g., to assess the overall environment and coordinate operation among the different sensors/devices—and/or provide instructions to the different devices based on the collection of inputs and programmed processing. It is also noted that in some implementations, the network interface **160** and the hub device **180** are integrated to one network device. Functionality described herein is representative of particular implementations of smart devices, control application(s) running on representative electronic device(s) (such as a smart phone), hub device(s) **180**, and server(s) coupled to hub device(s) via the Internet or other Wide Area Network. All or a portion of this functionality and associated operations can be performed by any elements of the described system—for example, all or a portion of the functionality described herein as being performed by an implementation of the hub device can be performed, in different system implementations, in whole or

in part on the server, one or more connected smart devices and/or the control application, or different combinations thereof.

**[0078]** FIG. 3 illustrates a network-level view of an extensible devices and services platform with which the smart home environment of FIG. 1 is integrated, in accordance with some implementations. The extensible devices and services platform **300** includes smart home provider server system **164**. Each of the intelligent, network-connected devices described with reference to FIG. 1 (e.g., **102**, **104**, **106**, **108**, **110**, **112**, **114**, **116** and **118**, identified simply as “devices” in FIGS. 2-4) may communicate with the smart home provider server system **164**. For example, a connection to the Internet **162** may be established either directly (for example, using 3G/4G connectivity to a wireless carrier), or through a network interface **160** (e.g., a router, switch, gateway, hub device, or an intelligent, dedicated whole-home controller node), or through any combination thereof.

**[0079]** In some implementations, the devices and services platform **300** communicates with and collects data from the smart devices of the smart home environment **100**. In addition, in some implementations, the devices and services platform **300** communicates with and collects data from a plurality of smart home environments across the world. For example, the smart home provider server system **164** collects home data **302** from the devices of one or more smart home environments **100**, where the devices may routinely transmit home data or may transmit home data in specific instances (e.g., when a device queries the home data **302**). Example collected home data **302** includes, without limitation, power consumption data, blackbody radiation data, occupancy data, HVAC settings and usage data, carbon monoxide levels data, carbon dioxide levels data, volatile organic compounds levels data, sleeping schedule data, cooking schedule data, inside and outside temperature humidity data, television viewership data, inside and outside noise level data, pressure data, video data, etc.

**[0080]** In some implementations, the smart home provider server system **164** provides one or more services **304** to smart homes and/or third parties. Example services **304** include, without limitation, software updates, customer support, sensor data collection/logging, remote access, remote or distributed control, and/or use suggestions (e.g., based on collected home data **302**) to improve performance, reduce utility cost, increase safety, etc. In some implementations, data associated with the services **304** is stored at the smart home provider server system **164**, and the smart home provider server system **164** retrieves and transmits the data at appropriate times (e.g., at regular intervals, upon receiving a request from a user, etc.).

**[0081]** In some implementations, the extensible devices and services platform **300** includes a processing engine **306**, which may be concentrated at a single server or distributed among several different computing entities without limitation. In some implementations, the processing engine **306** includes engines configured to receive data from the devices of smart home environments **100** (e.g., via the Internet **162** and/or a network interface **160**), to index the data, to analyze the data and/or to generate statistics based on the analysis or as part of the analysis. In some implementations, the analyzed data is stored as derived home data **308**.

**[0082]** Results of the analysis or statistics may thereafter be transmitted back to the device that provided home data

used to derive the results, to other devices, to a server providing a webpage to a user of the device, or to other non-smart device entities. In some implementations, usage statistics, usage statistics relative to use of other devices, usage patterns, and/or statistics summarizing sensor readings are generated by the processing engine 306 and transmitted. The results or statistics may be provided via the Internet 162. In this manner, the processing engine 306 may be configured and programmed to derive a variety of useful information from the home data 302. A single server may include one or more processing engines.

**[0083]** The derived home data 308 may be used at different granularities for a variety of useful purposes, ranging from explicit programmed control of the devices on a per-home, per-neighborhood, or per-region basis (for example, demand-response programs for electrical utilities), to the generation of inferential abstractions that may assist on a per-home basis (for example, an inference may be drawn that the homeowner has left for vacation and so security detection equipment may be put on heightened sensitivity), to the generation of statistics and associated inferential abstractions that may be used for government or charitable purposes. For example, processing engine 306 may generate statistics about device usage across a population of devices and send the statistics to device users, service providers or other entities (e.g., entities that have requested the statistics and/or entities that have provided monetary compensation for the statistics).

**[0084]** In some implementations, to encourage innovation and research and to increase products and services available to users, the devices and services platform 300 exposes a range of application programming interfaces (APIs) 310 to third parties, such as charities 314, governmental entities 316 (e.g., the Food and Drug Administration or the Environmental Protection Agency), academic institutions 318 (e.g., university researchers), businesses 320 (e.g., providing device warranties or service to related equipment, targeting advertisements based on home data), utility companies 324, and other third parties. The APIs 310 are coupled to and permit third-party systems to communicate with the smart home provider server system 164, including the services 304, the processing engine 306, the home data 302, and the derived home data 308. In some implementations, the APIs 310 allow applications executed by the third parties to initiate specific data processing tasks that are executed by the smart home provider server system 164, as well as to receive dynamic updates to the home data 302 and the derived home data 308.

**[0085]** For example, third parties may develop programs and/or applications (e.g., web applications or mobile applications) that integrate with the smart home provider server system 164 to provide services and information to users. Such programs and applications may be, for example, designed to help users reduce energy consumption, to preemptively service faulty equipment, to prepare for high service demands, to track past service performance, etc., and/or to perform other beneficial functions or tasks.

**[0086]** FIG. 4 illustrates an abstracted functional view 400 of the extensible devices and services platform 300 of FIG. 3, with reference to a processing engine 306 as well as devices of the smart home environment, in accordance with some implementations. Even though devices situated in smart home environments will have a wide variety of different individual capabilities and limitations, the devices

may be thought of as sharing common characteristics in that each device is a data consumer 402 (DC), a data source 404 (DS), a services consumer 406 (SC), and a services source 408 (SS). Advantageously, in addition to providing control information used by the devices to achieve their local and immediate objectives, the extensible devices and services platform 300 may also be configured to use the large amount of data that is generated by these devices. In addition to enhancing or optimizing the actual operation of the devices themselves with respect to their immediate functions, the extensible devices and services platform 300 may be directed to “repurpose” that data in a variety of automated, extensible, flexible, and/or scalable ways to achieve a variety of useful objectives. These objectives may be predefined or adaptively identified based on, e.g., usage patterns, device efficiency, and/or user input (e.g., requesting specific functionality).

**[0087]** FIG. 4 shows processing engine 306 as including a number of processing paradigms 410. In some implementations, processing engine 306 includes a managed services paradigm 410a that monitors and manages primary or secondary device functions. The device functions may include ensuring proper operation of a device given user inputs, estimating that (e.g., and responding to an instance in which) an intruder is or is attempting to be in a dwelling, detecting a failure of equipment coupled to the device (e.g., a light bulb having burned out), implementing or otherwise responding to energy demand response events, providing a heat-source alert, and/or alerting a user of a current or predicted future event or characteristic. In some implementations, processing engine 306 includes an advertising/communication paradigm 410b that estimates characteristics (e.g., demographic information), desires and/or products of interest of a user based on device usage. Services, promotions, products or upgrades may then be offered or automatically provided to the user. In some implementations, processing engine 306 includes a social paradigm 410c that uses information from a social network, provides information to a social network (for example, based on device usage), and/or processes data associated with user and/or device interactions with the social network platform. For example, a user’s status as reported to their trusted contacts on the social network may be updated to indicate when the user is home based on light detection, security system inactivation or device usage detectors. As another example, a user may be able to share device-usage statistics with other users. In yet another example, a user may share HVAC settings that result in low power bills and other users may download the HVAC settings to their smart thermostat 102 to reduce their power bills.

**[0088]** In some implementations, processing engine 306 includes a challenges/rules/compliance/rewards paradigm 410d that informs a user of challenges, competitions, rules, compliance regulations and/or rewards and/or that uses operation data to determine whether a challenge has been met, a rule or regulation has been complied with and/or a reward has been earned. The challenges, rules, and/or regulations may relate to efforts to conserve energy, to live safely (e.g., reducing the occurrence of heat-source alerts) (e.g., reducing exposure to toxins or carcinogens), to conserve money and/or equipment life, to improve health, etc. For example, one challenge may involve participants turning down their thermostat by one degree for one week. Those participants that successfully complete the challenge are

rewarded, such as with coupons, virtual currency, status, etc. Regarding compliance, an example involves a rental-property owner making a rule that no renters are permitted to access certain owner's rooms. The devices in the room having occupancy sensors may send updates to the owner when the room is accessed.

[0089] In some implementations, processing engine 306 integrates or otherwise uses extrinsic information 412 from extrinsic sources to improve the functioning of one or more processing paradigms. Extrinsic information 412 may be used to interpret data received from a device, to determine a characteristic of the environment near the device (e.g., outside a structure that the device is enclosed in), to determine services or products available to the user, to identify a social network or social-network information, to determine contact information of entities (e.g., public-service entities such as an emergency-response team, the police or a hospital) near the device, to identify statistical or environmental conditions, trends or other information associated with a home or neighborhood, and so forth.

[0090] FIG. 5 illustrates a representative operating environment 500 in which a hub device server system 508 provides data processing for monitoring and facilitating review of motion events in video streams captured by video cameras 118. As shown in FIG. 5, the hub device server system 508 receives video data from video sources 522 (including cameras 118) located at various physical locations (e.g., inside homes, restaurants, stores, streets, parking lots, and/or the smart home environments 100 of FIG. 1). Each video source 522 may be bound to one or more reviewer accounts, and the hub device server system 508 provides video monitoring data for the video source 522 to client devices 504 associated with the reviewer accounts. For example, the portable electronic device 166 is an example of the client device 504.

[0091] In some implementations, the smart home provider server system 164 or a component thereof serves as the hub device server system 508. In some implementations, the hub device server system 508 is a dedicated video processing server that provides video processing services to video sources and client devices 504 independent of other services provided by the hub device server system 508.

[0092] In some implementations, each of the video sources 522 includes one or more video cameras 118 that capture video and send the captured video to the hub device server system 508 substantially in real-time. In some implementations, each of the video sources 522 optionally includes a controller device (not shown) that serves as an intermediary between the one or more cameras 118 and the hub device server system 508. The controller device receives the video data from the one or more cameras 118, optionally, performs some preliminary processing on the video data, and sends the video data to the hub device server system 508 on behalf of the one or more cameras 118 substantially in real-time. In some implementations, each camera has its own on-board processing capabilities to perform some preliminary processing on the captured video data before sending the processed video data (along with metadata obtained through the preliminary processing) to the controller device and/or the hub device server system 508.

[0093] As shown in FIG. 5, in accordance with some implementations, each of the client devices 504 includes a client-side module 502. The client-side module 502 communicates with a server-side module 506 executed on the

hub device server system 508 through the one or more networks 162. The client-side module 502 provides client-side functionalities for the event monitoring and review processing and communications with the server-side module 506. The server-side module 506 provides server-side functionalities for event monitoring and review processing for any number of client-side modules 502 each residing on a respective client device 504. The server-side module 506 also provides server-side functionalities for video processing and camera control for any number of the video sources 522, including any number of control devices and the cameras 118.

[0094] In some implementations, the server-side module 506 includes one or more processors 512, a video storage database 514, device and account databases 516, an I/O interface to one or more client devices 518, and an I/O interface to one or more video sources 520. The I/O interface to one or more clients 518 facilitates the client-facing input and output processing for the server-side module 506. The databases 516 store a plurality of profiles for reviewer accounts registered with the video processing server, where a respective user profile includes account credentials for a respective reviewer account, and one or more video sources linked to the respective reviewer account. The I/O interface to one or more video sources 520 facilitates communications with one or more video sources 522 (e.g., groups of one or more cameras 118 and associated controller devices). The video storage database 514 stores raw video data received from the video sources 522, as well as various types of metadata, such as motion events, event categories, event category models, event filters, and event masks, for use in data processing for event monitoring and review for each reviewer account.

[0095] Examples of a representative client device 504 include, but are not limited to, a handheld computer, a wearable computing device, a personal digital assistant (PDA), a tablet computer, a laptop computer, a desktop computer, a cellular telephone, a smart phone, an enhanced general packet radio service (EGPRS) mobile phone, a media player, a navigation device, a game console, a television, a remote control, a point-of-sale (POS) terminal, vehicle-mounted computer, an ebook reader, or a combination of any two or more of these data processing devices or other data processing devices.

[0096] Examples of the one or more networks 162 include local area networks (LAN) and wide area networks (WAN) such as the Internet. The one or more networks 162 are, optionally, implemented using any known network protocol, including various wired or wireless protocols, such as Ethernet, Universal Serial Bus (USB), FIREWIRE, Long Term Evolution (LTE), Global System for Mobile Communications (GSM), Enhanced Data GSM Environment (EDGE), code division multiple access (CDMA), time division multiple access (TDMA), Bluetooth, Wi-Fi, voice over Internet Protocol (VoIP), Wi-MAX, or any other suitable communication protocol.

[0097] In some implementations, the hub device server system 508 is implemented on one or more standalone data processing apparatuses or a distributed network of computers. In some implementations, the hub device server system 508 also employs various virtual devices and/or services of third party service providers (e.g., third-party cloud service providers) to provide the underlying computing resources and/or infrastructure resources of the hub device server

system 508. In some implementations, the hub device server system 508 includes, but is not limited to, a handheld computer, a tablet computer, a laptop computer, a desktop computer, or a combination of any two or more of these data processing devices or other data processing devices.

[0098] The server-client environment 500 shown in FIG. 1 includes both a client-side portion (e.g., the client-side module 502) and a server-side portion (e.g., the server-side module 506). The division of functionalities between the client and server portions of operating environment 500 can vary in different implementations. Similarly, the division of functionalities between the video source 522 and the hub device server system 508 can vary in different implementations. For example, in some implementations, client-side module 502 is a thin-client that provides only user-facing input and output processing functions, and delegates all other data processing functionalities to a backend server (e.g., the hub device server system 508). Similarly, in some implementations, a respective one of the video sources 522 is a simple video capturing device that continuously captures and streams video data to the hub device server system 508 without no or limited local preliminary processing on the video data. Although many aspects of the present technology are described from the perspective of the hub device server system 508, the corresponding actions performed by the client device 504 and/or the video sources 522 would be apparent to ones skilled in the art without any creative efforts. Similarly, some aspects of the present technology may be described from the perspective of the client device or the video source, and the corresponding actions performed by the video server would be apparent to ones skilled in the art without any creative efforts. Furthermore, some aspects of the present technology may be performed by the hub device server system 508, the client device 504, and the video sources 522 cooperatively.

[0099] It should be understood that operating environment 500 that involves the hub device server system 508, the video sources 522 and the video cameras 118 is merely an example. Many aspects of operating environment 500 are generally applicable in other operating environments in which a server system provides data processing for monitoring and facilitating review of data captured by other types of electronic devices (e.g., smart thermostats 102, smart hazard detectors 104, smart doorbells 106, smart wall plugs 110, appliances 112 and the like).

[0100] The electronic devices, the client devices or the server system communicate with each other using the one or more communication networks 162. In an example smart home environment, two or more devices (e.g., the network interface device 160, the hub device 180, and the client devices 504-*m*) are located in close proximity to each other, such that they could be communicatively coupled in the same sub-network 162A via wired connections, a WLAN or a Bluetooth Personal Area Network (PAN). The Bluetooth PAN is optionally established based on classical Bluetooth technology or Bluetooth Low Energy (BLE) technology. This smart home environment further includes one or more other radio communication networks 162B through which at least some of the electronic devices of the video sources 522-*n* exchange data with the hub device 180. Alternatively, in some situations, some of the electronic devices of the video sources 522-*n* communicate with the network interface device 160 directly via the same sub-network 162A that couples devices 160, 180 and 504-*m*. In some implementa-

tions (e.g., in the network 162C), both the client device 504-*m* and the electronic devices of the video sources 522-*n* communicate directly via the network(s) 162 without passing the network interface device 160 or the hub device 180.

[0101] In some implementations, during normal operation, the network interface device 160 and the hub device 180 communicate with each other to form a network gateway through which data are exchanged with the electronic device of the video sources 522-*n*. As explained above, the network interface device 160 and the hub device 180 optionally communicate with each other via a sub-network 162A.

[0102] FIG. 6 is a block diagram illustrating a representative hub device 180 in accordance with some implementations. In some implementations, the hub device 180 includes one or more processing units (e.g., CPUs, ASICs, FPGAs, microprocessors, and the like) 602, one or more communication interfaces 604, memory 606, radios 640, and one or more communication buses 608 for interconnecting these components (sometimes called a chipset). In some implementations, the hub device 180 includes one or more input devices 610 such as one or more buttons for receiving input. In some implementations, the hub device 180 includes one or more output devices 612 such as one or more indicator lights, a sound card, a speaker, a small display for displaying textual information and error codes, etc. Furthermore, in some implementations, the hub device 180 uses a microphone and voice recognition or a camera and gesture recognition to supplement or replace the keyboard. In some implementations, the hub device 180 includes a location detection device 614, such as a GPS (global positioning satellite) or other geo-location receiver, for determining the location of the hub device 180.

[0103] The hub device 180 optionally includes one or more built-in sensors (not shown), including, for example, one or more thermal radiation sensors, ambient temperature sensors, humidity sensors, IR sensors, occupancy sensors (e.g., using RFID sensors), ambient light sensors, motion detectors, accelerometers, and/or gyroscopes.

[0104] The radios 640 enable and/or connect to one or more radio communication networks in the smart home environments, and allow a hub device to communicate with smart devices 204. In some implementations, the radios 640 are capable of data communications using any of a variety of custom or standard wireless protocols (e.g., IEEE 802.15.4, Wi-Fi, ZigBee, 6LoWPAN, Thread, Z-Wave, Bluetooth Smart, ISA100.11a, WirelessHART, MiWi, etc.) custom or standard wired protocols (e.g., Ethernet, HomePlug, etc.), and/or any other suitable communication protocol, including communication protocols not yet developed as of the filing date of this document. In some implementations, the radios 640 include multiple different physical radios, each of which implements a different communication protocol. For example, in some implementations the radios 640 include a Wi-Fi radio, a Bluetooth radio and an IEEE 802.15.4 radio, all of which operate at 2.4 GHz. In some implementations, some of the radios are combined. For example, in some implementations, a Bluetooth radio and a Wi-Fi radio are incorporated in a single chip coupled to a single antenna. In other implementations, a Bluetooth radio and an IEEE 802.15.4 radio are incorporated in a single chip coupled to a single antenna. Any combination of these radios can be implemented in any of the smart devices employed in a smart home environment.

[0105] Communication interfaces **604** include, for example, hardware capable of interfacing the one or more radios **640** with the hub device **180**, so as to enable data communications using any of a variety of custom or standard wireless protocols (e.g., IEEE 802.15.4, Wi-Fi, ZigBee, 6LoWPAN, Thread, Z-Wave, Bluetooth Smart, ISA100.11a, WirelessHART, MiWi, etc.) and/or any of a variety of custom or standard wired protocols (e.g., Ethernet, HomePlug, etc.), or any other suitable communication protocol, including communication protocols not yet developed as of the filing date of this document.

[0106] Memory **606** includes high-speed random access memory, such as DRAM, SRAM, DDR RAM, or other random access solid state memory devices; and, optionally, includes non-volatile memory, such as one or more magnetic disk storage devices, one or more optical disk storage devices, one or more flash memory devices, or one or more other non-volatile solid state storage devices. Memory **606**, or alternatively the non-volatile memory within memory **606**, includes a non-transitory computer readable storage medium. In some implementations, memory **606**, or the non-transitory computer readable storage medium of memory **606**, stores the following programs, modules, and data structures, or a subset or superset thereof:

[0107] Operating logic **616** including procedures for handling various basic system services and for performing hardware dependent tasks;

[0108] Hub device communication module **618** for connecting to and communicating with other network devices (e.g., network interface **160**, such as a router that provides Internet connectivity, networked storage devices, network routing devices, server system **508**, etc.) connected to one or more networks **162** via one or more communication interfaces **604** (wired or wireless);

[0109] Radio Communication Module **620** for connecting the hub device **180** to other devices (e.g., controller devices, smart devices **204** in smart home environment **100**, client devices **504**) via one or more radio communication devices (e.g., radios **640**);

[0110] User interface module **622** for providing and displaying a user interface in which settings, captured data, and/or other data for one or more devices (e.g., smart devices **204** in smart home environment **100**) can be configured and/or viewed; and

[0111] Hub device database **624**, including but not limited to:

[0112] Sensor information **6240** for storing and managing data received, detected, and/or transmitted by one or more sensors of the hub device **180** and/or one or more other devices (e.g., smart devices **204** in smart home environment **100**);

[0113] Device settings **6242** for storing operational settings for one or more devices (e.g., coupled smart devices **204** in smart home environment **100**); and

[0114] Communication protocol information **6244** for storing and managing protocol information for one or more protocols (e.g., standard wireless protocols, such as ZigBee, Z-Wave, etc., and/or custom or standard wired protocols, such as Ethernet).

[0115] Each of the above identified elements (e.g., modules stored in memory **206** of hub device **180**) may be stored in one or more of the previously mentioned memory devices (e.g., the memory of any of the smart devices in smart home

environment **100**, FIG. 1), and corresponds to a set of instructions for performing a function described above. The above identified modules or programs (i.e., sets of instructions) need not be implemented as separate software programs, procedures, or modules, and thus various subsets of these modules may be combined or otherwise re-arranged in various implementations. In some implementations, memory **606**, optionally, stores a subset of the modules and data structures identified above. Furthermore, memory **606**, optionally, stores additional modules and data structures not described above.

[0116] FIG. 7 is a block diagram illustrating the hub server system **508** in accordance with some implementations. The hub server system **508**, typically, includes one or more processing units (CPUs) **702**, one or more network interfaces **704** (e.g., including an I/O interface to one or more client devices and an I/O interface to one or more electronic devices), memory **706**, and one or more communication buses **708** for interconnecting these components (sometimes called a chipset). Memory **706** includes high-speed random access memory, such as DRAM, SRAM, DDR RAM, or other random access solid state memory devices; and, optionally, includes non-volatile memory, such as one or more magnetic disk storage devices, one or more optical disk storage devices, one or more flash memory devices, or one or more other non-volatile solid state storage devices. Memory **706**, optionally, includes one or more storage devices remotely located from one or more processing units **702**. Memory **706**, or alternatively the non-volatile memory within memory **706**, includes a non-transitory computer readable storage medium. In some implementations, memory **706**, or the non-transitory computer readable storage medium of memory **706**, stores the following programs, modules, and data structures, or a subset or superset thereof:

[0117] Operating system **710** including procedures for handling various basic system services and for performing hardware dependent tasks;

[0118] Network communication module **712** for connecting the hub server system **508** to other systems and devices (e.g., client devices, electronic devices, and systems connected to one or more networks **162**, FIGS. 1-5) via one or more network interfaces **704** (wired or wireless);

[0119] Server-side module **714**, which provides server-side functionalities for device control, data processing and data review, including but not limited to:

[0120] Data receiving module **7140** for receiving data from electronic devices (e.g., video data from a camera **118**, FIG. 1) via the hub device **180**, and preparing the received data for further processing and storage in the data storage database **7160**;

[0121] Hub and device control module **7142** for generating and sending server-initiated control commands to modify operation modes of electronic devices (e.g., devices of a smart home environment **100**), and/or receiving (e.g., from client devices **504**) and forwarding user-initiated control commands to modify operation modes of the electronic devices;

[0122] Data processing module **7144** for processing the data provided by the electronic devices, and/or preparing and sending processed data to a device for review (e.g., client devices **504** for review by a user); and

[0123] Server database **716**, including but not limited to:

[0124] Data storage database **7160** for storing data associated with each electronic device (e.g., each camera) of each user account, as well as data processing models, processed data results, and other relevant metadata (e.g., names of data results, location of electronic device, creation time, duration, settings of the electronic device, etc.) associated with the data, wherein (optionally) all or a portion of the data and/or processing associated with the hub device **180** or smart devices are stored securely;

[0125] Account database **7162** for storing account information for user accounts, including user account information, information and settings for linked hub devices and electronic devices (e.g., hub device identifications), hub device specific secrets, relevant user and hardware characteristics (e.g., service tier, device model, storage capacity, processing capabilities, etc.), user interface settings, data review preferences, etc., where the information for associated electronic devices includes, but is not limited to, one or more device identifiers (e.g., MAC address and UUID), device specific secrets, and displayed titles; and

[0126] Device Information Database **7164** for storing device information related to one or more hub devices, e.g., device identifiers and hub device specific secrets, independently of whether the corresponding hub devices have been associated with any user account.

[0127] Each of the above identified elements may be stored in one or more of the previously mentioned memory devices, and corresponds to a set of instructions for performing a function described above. The above identified modules or programs (i.e., sets of instructions) need not be implemented as separate software programs, procedures, or modules, and thus various subsets of these modules may be combined or otherwise re-arranged in various implementations. In some implementations, memory **706**, optionally, stores a subset of the modules and data structures identified above. Furthermore, memory **706**, optionally, stores additional modules and data structures not described above.

[0128] FIG. **8** is a block diagram illustrating a representative client device **504** associated with a user account in accordance with some implementations. The client device **504**, typically, includes one or more processing units (CPUs) **802**, one or more network interfaces **804**, memory **806**, and one or more communication buses **808** for interconnecting these components (sometimes called a chipset). Optionally, the client device also includes a user interface **810** and one or more built-in sensors **890** (e.g., accelerometer and gyroscope). User interface **810** includes one or more output devices **812** that enable presentation of media content, including one or more speakers and/or one or more visual displays. User interface **810** also includes one or more input devices **814**, including user interface components that facilitate user input such as a keyboard, a mouse, a voice-command input unit or microphone, a touch screen display, a touch-sensitive input pad, a gesture capturing camera, or other input buttons or controls. Furthermore, some of the client devices use a microphone and voice recognition or a camera and gesture recognition to supplement or replace the keyboard. In some implementations, the client device includes

one or more cameras, scanners, or photo sensor units for capturing images (not shown). Optionally, the client device includes a location detection device **816**, such as a GPS (global positioning satellite) or other geo-location receiver, for determining the location of the client device.

[0129] Memory **806** includes high-speed random access memory, such as DRAM, SRAM, DDR RAM, or other random access solid state memory devices; and, optionally, includes non-volatile memory, such as one or more magnetic disk storage devices, one or more optical disk storage devices, one or more flash memory devices, or one or more other non-volatile solid state storage devices. Memory **806**, optionally, includes one or more storage devices remotely located from one or more processing units **802**. Memory **806**, or alternatively the non-volatile memory within memory **806**, includes a non-transitory computer readable storage medium. In some implementations, memory **806**, or the non-transitory computer readable storage medium of memory **806**, stores the following programs, modules, and data structures, or a subset or superset thereof:

[0130] Operating system **818** including procedures for handling various basic system services and for performing hardware dependent tasks;

[0131] Network communication module **820** for connecting the client device **504** to other systems and devices (e.g., client devices, electronic devices, and systems connected to one or more networks **162**, FIGS. **1-5**) via one or more network interfaces **804** (wired or wireless);

[0132] Input processing module **822** for detecting one or more user inputs or interactions from one of the one or more input devices **814** and interpreting the detected input or interaction;

[0133] One or more applications **824** for execution by the client device (e.g., games, social network applications, smart home applications, and/or other web or non-web based applications) for controlling devices (e.g., sending commands, configuring settings, etc. to hub devices and/or other client or electronic devices) and for reviewing data captured by the devices (e.g., device status and settings, captured data, or other information regarding the hub device or other connected devices);

[0134] User interface module **622** for providing and displaying a user interface in which settings, captured data, and/or other data for one or more devices (e.g., smart devices **204** in smart home environment **100**) can be configured and/or viewed;

[0135] Client-side module **828**, which provides client-side functionalities for device control, data processing and data review, including but not limited to:

[0136] Hub device and device control module **8280** for generating control commands for modifying an operating mode of the hub device or the electronic devices in accordance with user inputs; and

[0137] Data review module **8282** for providing user interfaces for reviewing data processed by the hub server system **508**; and

[0138] Client data **830** storing data associated with the user account and electronic devices, including, but is not limited to:

[0139] Account data **8300** storing information related to both user accounts loaded on the client device and electronic devices (e.g., of the video sources **522**)



associated with the user accounts, wherein such information includes cached login credentials, hub device identifiers (e.g., MAC addresses and UUIDs), electronic device identifiers (e.g., MAC addresses and UUIDs), user interface settings, display preferences, authentication tokens and tags, password keys, etc.; and

[0140] Local data storage database **8302** for selectively storing raw or processed data associated with electronic devices (e.g., of the video sources **522**, such as a camera **118**).

[0141] Each of the above identified elements may be stored in one or more of the previously mentioned memory devices, and corresponds to a set of instructions for performing a function described above. The above identified modules or programs (i.e., sets of instructions) need not be implemented as separate software programs, procedures, modules or data structures, and thus various subsets of these modules may be combined or otherwise re-arranged in various implementations. In some implementations, memory **806**, optionally, stores a subset of the modules and data structures identified above. Furthermore, memory **806**, optionally, stores additional modules and data structures not described above.

[0142] FIG. 9 is a block diagram illustrating a representative smart device **204** in accordance with some implementations. In some implementations, the smart device **204** (e.g., any device of a smart home environment **100** (FIGS. 1 and 2), such as a camera **118**, a smart hazard detector **104**, a smart thermostat **102**, hub device **180**, etc.) includes one or more processing units (e.g., CPUs, ASICs, FPGAs, microprocessors, and the like) **902**, memory **906**, a communications module **942** that includes one or more radios **940** and radios **950**, communication interfaces **904**, and one or more communication buses **908** for interconnecting these components (sometimes called a chipset). In some implementations, user interface **910** includes one or more output devices **912** that enable presentation of media content, including one or more speakers and/or one or more visual displays. In some implementations, user interface **910** also includes one or more input devices **914**, including user interface components that facilitate user input such as a keyboard, a mouse, a voice-command input unit or microphone, a touch screen display, a touch-sensitive input pad, a gesture capturing camera, or other input buttons or controls. Furthermore, some smart devices **204** use a microphone and voice recognition or a camera and gesture recognition to supplement or replace the keyboard. In some implementations, the smart device **204** includes one or more image/video capture devices **918** (e.g., cameras, video cameras, scanners, photo sensor units). Optionally, the client device includes a location detection device **916**, such as a GPS (global positioning satellite) or other geo-location receiver, for determining the location of the smart device **204**.

[0143] The built-in sensors **990** include, for example, one or more thermal radiation sensors, ambient temperature sensors, humidity sensors, IR sensors, occupancy sensors (e.g., using RFID sensors), ambient light sensors, motion detectors, accelerometers, and/or gyroscopes.

[0144] The radio(s) **940** and radio(s) **950** enable one or more radio communication networks in the smart home environments, and allow a smart device **204** to communicate with other devices. In some implementations, the radios **940** are capable of data communications using any of a variety

of custom or standard wireless protocols (e.g., IEEE 802.15.4, Wi-Fi, ZigBee, 6LoWPAN, Thread, Z-Wave, Bluetooth Smart, ISA100.11a, WirelessHART, MiWi, etc.) custom or standard wired protocols (e.g., Ethernet, HomePlug, etc.), and/or any other suitable communication protocol, including communication protocols not yet developed as of the filing date of this document.

[0145] Communication interfaces **950** include, for example, hardware capable of interfacing the one or more radios **940** and **950** with the smart device **204**, so as to enable data communications using any of a variety of custom or standard wireless protocols (e.g., IEEE 802.15.4, Wi-Fi, ZigBee, 6LoWPAN, Thread, Z-Wave, Bluetooth Smart, ISA100.11a, WirelessHART, MiWi, etc.) and/or any of a variety of custom or standard wired protocols (e.g., Ethernet, HomePlug, etc.), or any other suitable communication protocol, including communication protocols not yet developed as of the filing date of this document. In some implementations, each radio(s) **940** and radio(s) **950** has a respective communication interface **950** for facilitating and managing data communications for the respective radio, while in other implementations, multiple radios **940** and/or **950** are managed by a single respective communication interface **950**.

[0146] In some implementations, radios **940** and/or radios **950** are configured to transmit and receive the same or distinct types of signals in the smart home environment. For example, radios **940** may include transceivers configured to transmit data between other devices (e.g., smart devices) within the smart home environment (e.g., IEEE 802.15.4 communications protocol for unilaterally/bilaterally transmitting data between and among smart devices). Signals transmitted between devices may include, for example, signals directed to critical hazard information (e.g., pings indicating the detection of smoke) or device status information (e.g., ping indicating low battery). In contrast, in some implementations, the radios **950** may include transceivers configured to transmit high-bandwidth data across data networks (e.g., IEEE 802.11 (Wi-Fi) for uploading a video stream to a smart home provider server system **164**). In some implementations, the radios **940** and/or the radios **950** include transceivers configured for close-range communications with devices (e.g., Bluetooth communications protocol for device provisioning). In some implementations, the radios **940** and/or the radios **950** include transceivers configured to transmit low-power signals (e.g., smart hazard detectors **104** not connected to a persistent power source). In some implementations, radios **940** and/or radios **950** are configured to transmit multiple types of signals in the smart home environment (e.g., a Wi-Fi radio **950** uploads video stream data to the smart home provider server system **164**, in addition to routing received beacons to other nearby smart devices). In some implementations, the radios **940** and/or the radios **950** of a respective device include transceivers for directly and communicably bridging the respective device to other devices (e.g., pairing devices directly via Bluetooth, rather than communicating via a router by using Wi-Fi). In some implementations, the radios **940** and/or the radios **950** are configured to translate signals received through a first radio **940**, and further to re-transmit the translated signals using the first radio **940** and/or a radio **950** (e.g., a proprietary message format is received via Bluetooth and translated, where the translated messages are re-transmitted to other devices using Wi-Fi).

[0147] The communications module 942 includes a variety of components for enabling the receiving and transmitting of signals by a respective smart device 204, including one or more amplifiers, oscillators, antennas, filters, switches, memory, firmware, and/or any other support circuits or circuit components. In some implementations, the one or more radios 940 and radios 950 are integrated components of the communications module 942 (e.g., System on a Chip (SOC)). In some implementations, the one or more radios 940 and radios 950 have respective circuit components (e.g., radios 940 having a corresponding antenna 1402-1, radios 950 having a corresponding antenna 1402-2). Alternatively, the one or more radios 940 and radios 950 share one or more circuit components (e.g., radio 950-1 and radio 950-2 sharing an antenna 1402-2, FIG. 15B).

[0148] Memory 906 includes high-speed random access memory, such as DRAM, SRAM, DDR RAM, or other random access solid state memory devices; and, optionally, includes non-volatile memory, such as one or more magnetic disk storage devices, one or more optical disk storage devices, one or more flash memory devices, or one or more other non-volatile solid state storage devices. Memory 906, or alternatively the non-volatile memory within memory 906, includes a non-transitory computer readable storage medium. In some implementations, memory 906, or the non-transitory computer readable storage medium of memory 906, stores the following programs, modules, and data structures, or a subset or superset thereof:

[0149] Operating logic 920 including procedures for handling various basic system services and for performing hardware dependent tasks;

[0150] Device communication module 922 for connecting to and communicating with other network devices (e.g., network interface 160, such as a router that provides Internet connectivity, networked storage devices, network routing devices, server system 508, etc.) connected to one or more networks 162 via one or more communication interfaces 904 (wired or wireless);

[0151] Radio Communication Module 924 for connecting the smart device 204 to other devices (e.g., controller devices, smart devices 204 in smart home environment 100, client devices 504) via one or more radio communication devices (e.g., radios 940)

[0152] Input processing module 926 for detecting one or more user inputs or interactions from the one or more input devices 914 and interpreting the detected inputs or interactions;

[0153] User interface module 928 for providing and displaying a user interface in which settings, captured data, and/or other data for one or more devices (e.g., the smart device 204, and/or other devices in smart home environment 100) can be configured and/or viewed;

[0154] One or more applications 930 for execution by the smart device 930 (e.g., games, social network applications, smart home applications, and/or other web or non-web based applications) for controlling devices (e.g., executing commands, sending commands, and/or configuring settings of the smart device 204 and/or other client/electronic devices), and for reviewing data captured by devices (e.g., device status and settings, captured data, or other information regarding the smart device 204 and/or other client/electronic devices);

[0155] Device-side module 932, which provides device-side functionalities for device control, data processing and data review, including but not limited to:

[0156] Command receiving module 9320 for receiving, forwarding, and/or executing instructions and control commands (e.g., from a client device 504, from a smart home provider server system 164, from user inputs detected on the user interface 910, etc.) for operating the smart device 204; and

[0157] Data processing module 9322 for processing data captured or received by one or more inputs (e.g., input devices 914, image/video capture devices 918, location detection device 916), sensors (e.g., built-in sensors 990), interfaces (e.g., communication interfaces 904, radios 940), and/or other components of the smart device 204, and for preparing and sending processed data to a device for review (e.g., client devices 504 for review by a user);

[0158] Device data 934 storing data associated with devices (e.g., the smart device 204), including, but is not limited to:

[0159] Account data 9340 storing information related to user accounts loaded on the smart device 204, wherein such information includes cached login credentials, smart device identifiers (e.g., MAC addresses and UUIDs), user interface settings, display preferences, authentication tokens and tags, password keys, etc.; and

[0160] Local data storage database 9342 for selectively storing raw or processed data associated with the smart device 204 (e.g., video surveillance footage captured by a camera 118);

[0161] Bypass module 936 for detecting whether radio(s) 940 and/or radio(s) 950 are transmitting signals via respective antennas coupled to the radio(s) 940 and/or radio(s) 950 (e.g., detecting whether radio 950 is transmitting via antenna 1402-2) and to accordingly couple radio(s) 940 and/or radio(s) 950 to their respective antennas either via a bypass line (e.g., bypass line 1408) or an amplifier (e.g., low noise amplifier 1406-2); and

[0162] Transmission access module 938 for granting or denying transmission access to one or more radio(s) 940 and/or radio(s) 950 (e.g., based on detected control signals and transmission requests).

[0163] Each of the above identified elements may be stored in one or more of the previously mentioned memory devices, and corresponds to a set of instructions for performing a function described above. For example, in some implementations, the one or more radios 940 and radios 950 include respective memory and firmware for storing one or more programs/executable modules of the memory 906. The above identified modules or programs (i.e., sets of instructions) need not be implemented as separate software programs, procedures, or modules, and thus various subsets of these modules may be combined or otherwise re-arranged in various implementations. In some implementations, memory 906, optionally, stores a subset of the modules and data structures identified above. Furthermore, memory 906, optionally, stores additional modules and data structures not described above.

[0164] FIG. 10 is a block diagram illustrating the smart home provider server system 164 in accordance with some implementations. The smart home provider server system

**164**, typically, includes one or more processing units (CPUs) **1002**, one or more network interfaces **1004** (e.g., including an I/O interface to one or more client devices and an I/O interface to one or more electronic devices), memory **1006**, and one or more communication buses **1008** for interconnecting these components (sometimes called a chipset). Memory **1006** includes high-speed random access memory, such as DRAM, SRAM, DDR RAM, or other random access solid state memory devices; and, optionally, includes non-volatile memory, such as one or more magnetic disk storage devices, one or more optical disk storage devices, one or more flash memory devices, or one or more other non-volatile solid state storage devices. Memory **1006**, optionally, includes one or more storage devices remotely located from one or more processing units **1002**. Memory **1006**, or alternatively the non-volatile memory within memory **1006**, includes a non-transitory computer readable storage medium. In some implementations, memory **1006**, or the non-transitory computer readable storage medium of memory **1006**, stores the following programs, modules, and data structures, or a subset or superset thereof:

[0165] Operating system **1010** including procedures for handling various basic system services and for performing hardware dependent tasks;

[0166] Network communication module **1012** for connecting the smart home provider server system **164** to other systems and devices (e.g., client devices, electronic devices, and systems connected to one or more networks **162**, FIGS. 1-5) via one or more network interfaces **1004** (wired or wireless);

[0167] Server-side module **1014**, which provides server-side functionalities for device control, data processing and data review, including but not limited to:

[0168] Data receiving module **10140** for receiving data from electronic devices (e.g., video data from a camera **118**, FIG. 1), and preparing the received data for further processing and storage in the data storage database **10160**;

[0169] Device control module **10142** for generating and sending server-initiated control commands to modify operation modes of electronic devices (e.g., devices of a smart home environment **100**), and/or receiving (e.g., from client devices **504**) and forwarding user-initiated control commands to modify operation modes of the electronic devices;

[0170] Data processing module **10144** for processing the data provided by the electronic devices, and/or preparing and sending processed data to a device for review (e.g., client devices **504** for review by a user); and

[0171] Server database **1016**, including but not limited to:

[0172] Data storage database **10160** for storing data associated with each electronic device (e.g., each camera) of each user account, as well as data processing models, processed data results, and other relevant metadata (e.g., names of data results, location of electronic device, creation time, duration, settings of the electronic device, etc.) associated with the data, wherein (optionally) all or a portion of the data and/or processing associated with the electronic devices are stored securely; and

[0173] Account database **10162** for storing account information for user accounts, including user

account information, information and settings for linked hub devices and electronic devices (e.g., hub device identifications), hub device specific secrets, relevant user and hardware characteristics (e.g., service tier, device model, storage capacity, processing capabilities, etc.), user interface settings, data review preferences, etc., where the information for associated electronic devices includes, but is not limited to, one or more device identifiers (e.g., MAC address and UUID), device specific secrets, and displayed titles.

[0174] Each of the above identified elements may be stored in one or more of the previously mentioned memory devices, and corresponds to a set of instructions for performing a function described above. The above identified modules or programs (i.e., sets of instructions) need not be implemented as separate software programs, procedures, or modules, and thus various subsets of these modules may be combined or otherwise re-arranged in various implementations. In some implementations, memory **1006**, optionally, stores a subset of the modules and data structures identified above. Furthermore, memory **1006**, optionally, stores additional modules and data structures not described above.

[0175] Furthermore, in some implementations, the functions of any of the devices and systems described herein (e.g., hub device **180**, hub server system **508**, client device **504**, smart device **204**, smart home provider server system **164**) are interchangeable with one another and may be performed by any other devices or systems, where the corresponding sub-modules of these functions may additionally and/or alternatively be located within and executed by any of the devices and systems. The devices and systems shown in and described with respect to FIGS. 6-10 are merely illustrative, and different configurations of the modules for implementing the functions described herein are possible in various implementations.

[0176] As described with respect to FIGS. 6-10, devices in a smart home environment (e.g., smart devices **204** in FIG. 2, such as cameras **118**, smart thermostats **102**, smart hazard detectors **104**, etc. of a smart home environment **100**, FIG. 1) include a host of circuit components and interfaces for enabling communications with other systems, devices, and/or servers. For example, in some implementations, smart devices include a communications module (e.g., communications module **942**, FIG. 9) which comprises one or more radios **940** and/or radios **950** for receiving and transmitting signals to other devices and across networks (sometimes referred to generally as “transceivers” or “transceiver devices”). In some implementations, the one or more radios **940** and radios **950** are components of a single integrated circuit (e.g., System on a Chip (SOC)). Given the typical physical compactness of smart devices, components of the communications module **942** and other components of the device are often collocated in close physical proximity with one another. For example, a typical smart device may contain multiple radio antennas, memory devices, sensors, chips, and other electronic components. As a consequence of their close physical spacing within smart devices, however, and in combination with components coming into close contact with conductive materials (e.g., metal casing, camera stand, wires, etc.), device components, such as antennas, are typically poorly isolated from transmissions of one another. Additionally, because these devices sometimes share the same or close frequency bands in operation (e.g.,

IEEE 802.11 (i.e., Wi-Fi) and 802.15.4 sharing 2.4 GHz frequency band), signals transmitted by one component tend to interfere with signals transmitted and/or received by other components. Ultimately, components of the communications module 942 typically achieve poor signal-to-noise ratio (SNR), distortion, degraded analog signal quality, and increased bit error rate (BER).

[0177] Furthermore, the poor isolation of these devices has an additional impact on the maximum input power of device components, since the transmission power of signals transmitting by one transceiver adds unexpectedly to the expected transmission of signals simultaneously received by other nearby transceivers. Sensitive device components are thus often risk of damage when their input power thresholds are exceeded. For example, referring to the front end module 1400 of the smart device 204 in FIG. 14, the low noise amplifier 1406-2 typically offers higher sensitivity to received signals, but consequently has a lower input power threshold than alternative amplifiers. Thus, the transmission power of antenna 1402-2, which adds to the transmission power of any signals received by antenna 1402-1, risks damaging components such as the low noise amplifier 1406-2.

[0178] Various schemes and techniques are described for lessening the harmful effects arising from poorly isolated transceivers in smart devices, a strategy generally referred to as coexistence. In particular, FIGS. 11-13 illustrate various component layout strategies for achieving improved coexistence for various devices, in accordance with some implementations. Furthermore, FIG. 14 illustrates a block diagram of a communications module 942 of a smart device utilizing bypass circuitry, and FIG. 22 is a flow diagram illustrating a method of coexistence using bypass circuitry, in accordance with some implementations. Moreover, FIGS. 15A-15G illustrate the use of control signals in a coexistence scheme, and FIGS. 23A-23F are flow diagrams illustrating methods of using control signals in a coexistence scheme, in accordance with some implementations.

[0179] Implementations and techniques described with respect to FIGS. 11 through 15 may be combined in whole or in part to achieve improved coexistence. For example, implementations described with respect to FIGS. 15A-15G (and corresponding methods of operation) may serve as an additional or supplementary measures for achieving optimal coexistence and operation of multiple radios in the event that implementations described with respect to FIG. 14 fail or malfunction (e.g., if the communications module 942 fails to engage the bypass line 1408, coexistence can still be achieved through software/firmware-based implementations described in FIGS. 15A-15G).

[0180] FIGS. 11A-11M illustrate various assembly views of a camera device 118, in accordance with some implementations. In particular, the embodiments illustrate the placement of the components as part of a component layout strategy for achieving improved coexistence. Components of a camera 118 (e.g., where the camera is a smart device 204, FIG. 9) and various implementations are described in greater detail throughout (e.g., FIGS. 9, 14, and 15).

[0181] Specifically, FIGS. 11A and 11B illustrate perspective views of an assembled camera device 118. The camera device 118 captures multimedia data (image, video, and audio data) in real-time, and communicates raw or processed multimedia data to its users via a remote surveillance server.

The captured raw multimedia data are optionally processed locally in the camera device 118 or remotely within the remote surveillance server.

[0182] FIG. 11C illustrates a view of the camera device 118 in which the plastic cover 1102 is removed from the camera device 118 assembly. FIGS. 11D and 11E further illustrate views of the camera device 118 and the locations in which one or more antennas (e.g., 1104-1 and 1104-2) are positioned with respect to the plastic cover 1102 of the camera device 118 assembly. As shown in FIG. 11D, a cable (e.g., RF coaxial cable) connects the antenna 1104-2 to the main circuit board of the camera device 118 (which is illustrated with greater detail in FIGS. 11H and 11I). Although not shown, in some implementations, the antenna 1104-1 is also connected to the main circuit board using a similar cable.

[0183] The placement of antennas 1104 within the camera device 118 assembly is such that interference from conductive and transmitting components is minimized. Placement of antennas 1104 is based at least in part on the type of antennas used. In some implementations, antennas may be integrated into or secured by stickers or tape (or alternatively fixed using a non-conductive adhesive). By selecting the material of the enclosed housing of the camera assembly to be a less (or non) conductive material, such as plastic (e.g., plastic cover 1102), these antennas may be fixed adhesively along the inside of the enclosing housing, thereby reducing the impact of interference otherwise experienced. Antennas 1104 may also be stamped sheet metal antennas. These antennas may be constructed as three-dimensional sheet metal antennas that are mounted on the circuit board where nearby the location of the corresponding transceiver. An example is a Planar Inverted-F Antenna (PIFA) stamped metal antenna. Alternatively, antennas 1104 may be trace antennas integrated into/onto a printed circuit board (PCB). In some implementations, the trace is laminated on the surface of the PCD. In other cases, the traces may occupy several layers of a multilayer board. Chip antennas may also be used, which are passive surface mounted antenna components often made from ceramic. Optionally, antennas 1104 may be antennas external to the enclosed housing of the camera assembly.

[0184] FIG. 11F is an exploded view of a camera device 118 in accordance with some implementations. This view of the camera device 118 illustrates a camera lens 1108, a plurality of LEDs 1106, the one or more antennas 1104.

[0185] In accordance with a regular monitor mode, the camera device 118 is configured to provide video monitoring and security in a smart home environment that is illuminated by visible light sources (e.g., the sun or light bulbs). In some implementations, the camera device 118 includes alternative operation modes, such as a night vision mode and a depth imaging mode. Each of the alternative operation modes is associated with a respective illumination condition. For example, in the night vision mode, the camera device 118 is configured to capture activities in the smart home environment at night when no or limited visible light illumination is available. In the depth imaging mode, the camera device 118 is configured to create a depth map or image for the corresponding field of view in the smart home environment. The depth map can be subsequently used in the regular monitor mode for accurate identification of objects in the smart home environment. In some implementations, the depth image is created based on one or more images

captured when part of the field of view is selectively illuminated. Therefore, in some implementations, the camera device **118** is configured to include a LED illumination system, and use it as an internal light source to provide illumination in the smart home environment according to the respective illumination condition associated with each alternative operation mode of the camera device **118**.

[0186] Specifically, in some implementations, the plurality of LEDs **1106** includes infrared LEDs **1106**. The infrared LEDs **1106** are enclosed within a dark-colored, infrared-transparent plastic cover **1102** of the camera device **118**, and therefore are invisible from the exterior of the camera device **118**. Given that the plastic cover **1102** permits infrared light to pass through it, the camera device **118** can rely on the infrared LEDs **1106** to provide illumination at night. In the night vision mode, the plurality of LEDs is powered on to illuminate the field of view with infrared light at night. The camera device **118** includes infrared image sensors that capture infrared images or video clips of the field of view. In the depth imaging mode, the plurality of LEDs **1106** is grouped into a number of LED sets, and each LED set is selectively powered up to illuminate respective part of a field of view associated with a venue where the camera device **118** is located. Images captured in association with these LED sets are combined to generate a depth map of the entire field of view at the venue.

[0187] Alternatively, in some implementations, the plurality of LEDs **1106** is a mix of infrared and visible light LEDs, including at least one infrared LED and at least one visible light LED. In the night vision mode, the at least one infrared LED of the plurality of LEDs is powered on to illuminate the field of view with infrared light.

[0188] In some implementations, the plurality of LEDs **1106** is disposed on an internal assembly structure of the camera device **118**, and configured to surround the camera lens **1108** of the camera device **118**. In some implementations, as shown in the inset of FIG. **11F**, each LED is optionally tilted with an angle with respect to the optical axis that passes through a center **340** of the camera lens **1108**. Here, the optical axis is perpendicular to the lens surface at the center of the camera lens **1108**. In some implementations, each LED is tilted away from the optical axis of the camera with the angle in the range of 20-40 degrees. In this example, the plurality of LEDs **1106** includes eight LEDs that are grouped in four pairs of LEDs. The four pairs of LEDs are disposed symmetrically within four quadrants surrounding the camera lens **1108**. In some implementations, a mechanical or electrical component **314** is placed between two LED pairs or between two LEDs within a LED pair. It is noted that the camera lens **1108** can be surrounded by a number of LEDs having a different physical arrangement from the above example (e.g., the camera lens **1108** is surrounded by a hundred LEDs distributed uniformly in three layers surrounding the camera lens **1108**).

[0189] In some implementations, the one or more antennas **1104** are attached on an interior wall of the camera cover **1102** according to the form factor of the camera device **118**. Each of the one or more antennas **1104** is positioned at a respective preferred location with a respective preferred orientation with respect to the other antennas to suppress or reduce the impact from the presence and interference of the other antennas. In some situations, the receiving element **206** and the base assembly **208** are made from metal material, and each of the one or more antennas **1104** is

positioned at a respective preferred location with a respective preferred orientation with respect to the receiving element **206** and the base assembly **208** to suppress or reduce the impact from their presence. To render the preferred location and orientation, each of the one or more antennas **1104** is marked with a respective alignment mark that is configured to guide assembly of the respective antenna onto the interior wall of the camera cover **1102**.

[0190] In some implementations, the one or more antennas include at least a first antenna and a second antenna. The first antenna is configured to wirelessly transfer data captured by the camera device **118** over a wireless local area network (WLAN), and the second antenna is configured to communicate configuration data associated with the WLAN via a first radio network for the purposes of commissioning the camera device **118** into the WLAN. In some implementations, the camera device **118** further includes a third antenna to allow the camera device **118** to communicate with a local hub device (e.g., the hub device **180** shown in FIG. **1**) via a second radio network that is distinct from the first radio network. In some implementations, the WLAN and the first and second radio networks are associated with custom or standard wireless protocols (e.g., IEEE 802.15.4, Wi-Fi, ZigBee, 6LoWPAN, Thread, Z-Wave, Bluetooth Smart, ISA100.11a, WirelessHART, MiWi, etc.). In a specific example, the first, second and third antennas are configured to transfer their respective data wirelessly according to IEEE 802.11, IEEE 802.15.4 and ZigBee specifications, respectively.

[0191] Further, in some implementations, the one or more antennas **1104** are electrically coupled to separate wireless transmitter circuits that operate on distinct frequency bands, and transmit wireless signals at the distinct frequency bands concurrently. In some implementations, the one or more antennas **1104** are electrically coupled to a duplex filter, or a switch that controls their connections to a single wireless receiver circuit.

[0192] FIGS. **11G-11M** illustrate additional views of the camera device **118**. Particularly, FIG. **11G** illustrates exploded views of the camera device **118**. FIGS. **11H** and **11I** illustrate top and bottom views, respectively, of a main circuit board of the camera device **118**. Additionally, FIGS. **11J** and **11K** illustrate top and bottom views, respectively, of a sensor board of the camera device **118**. Moreover, FIGS. **11L** and **11M** illustrate top and bottom views, respectively, of an IR LED circuit board of the camera device **118**.

[0193] In some implementations, a camera assembly includes an enclosed housing having a rear surface, a front surface, and a periphery (e.g., camera **118**, FIGS. **11A-11M**). In some implementations, the camera assembly further includes a lens module located within the housing and configured to receive light via the front surface (e.g., lens **1108**, FIG. **11F**). In some implementations, video data captured by the lens module is exchanged between the camera assembly and a server using a wireless local area network.

[0194] In some implementations, the camera assembly further includes communication circuitry located within the housing and configured to wireless communicate over a plurality of different communication protocols (e.g., main circuit board of the camera device **118** that includes multiple transceivers). In some implementations, the communication circuitry includes a first circuit configured for communication over the first communication protocol (e.g., Wi-Fi

transceiver) and a second circuit configured for communication over the second communication protocol (e.g., 802.15.4 transceiver), wherein the first circuit and the second circuit are distinct. In some implementations, the communication circuitry is an integrated circuit configured for communication over both the first and second communication protocols (e.g., radios **950**, which includes a radio **950-1** for Bluetooth LE, and a radio **950-2** for Wi-Fi, FIG. **15B**). In some implementations, the communication circuitry is configured to wireless communicate over at least three different communication protocols (e.g., Wi-Fi, 802.15.4, and Bluetooth LE). In some implementations, the second antenna is further configured for communication over a third one of the communication protocols. In some implementations, the communication circuitry is further configured to provide transmission access for communicating over the first communication protocol while denying transmission access for communicating over the second communication protocol, while detecting an activated priority control signal (e.g., using control signals as described with respect to FIGS. **15A-15G**).

**[0195]** In some implementations, the camera assembly further includes a first antenna arranged at a first location on an inner surface of the periphery (e.g., antenna **1104-1**), the first antenna configured for communication over a first one of the communication protocols (e.g., Wi-Fi), and a second antenna (e.g., antenna **1104-2**) arranged at a second location on the inner surface of the periphery, the second location being different than the first location, the second antenna configured for communication over a second one of the communication protocols (e.g., 802.15.4). In some implementations, the first antenna is arranged at the first location on the inner surface of the periphery and/or the second antenna is arranged at the second location on the inner surface of the periphery by an adhesive material (e.g., FIG. **11E**). In some implementations, the first antenna has a first orientation and the second antenna has a second orientation such that the impact from the presence and interference of each other antenna are suppressed (e.g., orienting antennas **1104-1** and **1104-2** and different angles with respect to each other and other components within the camera assembly). In some implementations, the first antenna and the second antenna are marked with a respective alignment mark that is configured to guide the assembly of the respective antenna onto the interior wall of the camera lid.

**[0196]** In some implementations, the first antenna and the second antenna are configured to operate at the same frequency (e.g., 2.4 GHz). In some implementations, the first antenna and the second antenna are configured to operate at distinct frequencies (e.g., 2.4 GHz and 5 GHz). In some implementations, the first antenna is configured to transmit and receive, over the first communication protocol, signals comprising one or more of alerts, control signals and status information to and from other smart home devices (e.g., emergency alerts from a hazard detector **104** using 802.15.4, or any signals transmitted/received by any of the smart devices **204** described with respect to FIGS. **1-13**). Furthermore, the second antenna is configured to transmit and receive, over the second communication protocol signals for configuring the smart home device (e.g., Bluetooth LE for provisioning and setting up the camera **118**), and over the third communication protocol data corresponding to video captured by the smart home device (e.g., Wi-Fi for streaming video data).

**[0197]** In some implementations, the first antenna or the second antenna is configured to transmit and receive wireless signals in a wireless local area network according to the IEEE 802.11 specifications. In some implementations, wherein the first antenna or the second antenna is configured to transmit and receive wireless signals in a wireless personal area network according to the IEEE 802.15.4 standard. In some implementations, the first antenna or the second antenna is configured to transmit and receive wireless signals according to the Bluetooth Low Energy standard. In some implementations, the first antenna and the second antenna are electrically coupled to a duplex that controls their connections to a single wireless receiver circuit.

**[0198]** In some implementations, the camera assembly further includes a loop arm that is configured to hold the enclosed housing when the enclosed housing is inserted within a cutout opening in the loop arm. In some implementations, the loop arm is made from metal material, and the first location of the first antenna and the second location of the second antenna are such that the impact from the presence of the metal loop arm is suppressed (e.g., placed in a location that is farthest from the location at which the loop arm and the enclosed housing make contact).

**[0199]** FIGS. **12A-12C** illustrate various views of a smart thermostat (e.g., smart thermostat **102**, FIG. **1**) that may be used as part of a smart home environment **100**, as previously described.

**[0200]** Specifically, FIG. **12A** illustrates an exploded perspective view of the smart thermostat **102** with respect to its two main components, which are the head unit **1200-A** and the back plate **1200-B**. The head unit **1200-A** includes a head unit circuit board **1250** (described in further detail with respect to FIG. **12B**), and the back plate **1200-B** includes a backplate circuit board **1260** (described in further detail with respect to FIG. **12C**). Further technical and/or functional descriptions of various ones of the electrical and mechanical components illustrated hereinbelow can be found in one or more of the commonly assigned incorporated applications, such as U.S. Ser. No. 13/199,108, supra. In the drawings shown, the “z” direction is outward from the wall, the “y” direction is the head-to-toe direction relative to a walk-up user, and the “x” direction is the user’s left-to-right direction.

**[0201]** FIG. **12B** illustrates a head-on view of the head unit circuit board **1250** for the smart thermostat, which comprises a head unit microprocessor **1202** (such as a Texas Instruments AM3703 chip) and an associated oscillator **1204**, along with DDR SDRAM memory **1206**, and mass NAND storage **1208**. For Wi-Fi capability, there is provided in a separate compartment of RF shielding **1210** a Wi-Fi module **1212**, such as a Murata Wireless Solutions LBWA19XSLZ module, which is based on the Texas Instruments WL1270 chipset supporting the 802.11 b/g/n WLAN standard. For the Wi-Fi module **1212** is supporting circuitry **1214** including an oscillator **1216**. For ZigBee capability, there is provided also in a separately shielded RF compartment a ZigBee module **1218**, which can be, for example, a C2530F256 module from Texas Instruments. For the ZigBee module **1218** there is provided supporting circuitry **1220** including an oscillator **1222** and a low-noise amplifier **1224**. Also provided is display backlight voltage conversion circuitry **1226**, piezoelectric driving circuitry **1228**, and power management circuitry **1230** (local power rails, etc.). Provided on a flex circuit **1232** that attaches to the back of the

head unit circuit board by a flex circuit connector **1234** is a proximity and ambient light sensor (PROX/ALS), more particularly a Silicon Labs SI1142 Proximity/Ambient Light Sensor with an I2C Interface. Also provided is battery charging-supervision-disconnect circuitry **1236**, and spring/RF antennas **1238**. Also provided is a temperature sensor **1344** (rising perpendicular to the circuit board in the +z direction containing two separate temperature sensing elements at different distances from the circuit board), and a PIR motion sensor **1242**. Notably, even though the PROX/ALS and temperature sensors **1244** and PIR motion sensor **1246** are physically located on the head unit circuit board **1940**, all these sensors are polled and controlled by the low-power backplate microcontroller on the backplate circuit board, to which they are electrically connected. Optionally, in some implementations, the head unit circuit board includes a Bluetooth module **1248**, and additional circuitry (not shown) which includes one or more oscillators, amplifiers, and/or any other support circuitry. In some implementations, the head unit circuit board includes one or more integrated circuits which include a combination of radios and transceivers. For example, in some implementations, the Wi-Fi module **1212** and the Bluetooth module **1248** comprise a single chip, wherein the Wi-Fi module **1212** and the Bluetooth module **1248** transmit and receive signals using a single antenna **1238**. Various implementations of transceivers (e.g., radios **940**, radios **950**) are described in greater detail with respect to FIGS. **9** and **14-15G**.

**[0202]** FIG. **12C** illustrates a rear view of the backplate circuit board **1260**, comprising a backplate processor/microcontroller **1262**, such as a Texas Instruments MSP430F System-on-Chip Microcontroller that includes an on-board memory **1264**. The backplate circuit board **1260** further comprises power supply circuitry **1266**, which includes power-stealing circuitry, and switch circuitry **1268** for each HVAC respective HVAC function. For each such function the switch circuitry **1268** includes an isolation transformer **1270** and a back-to-back NFET package **1272**. The use of FETs in the switching circuitry allows for “active power stealing”, i.e., taking power during the HVAC “ON” cycle, by briefly diverting power from the HVAC relay circuit to the reservoir capacitors for a very small interval, such as 100 micro-seconds. This time is small enough not to trip the HVAC relay into the “off” state but is sufficient to charge up the reservoir capacitors. The use of FETs allows for this fast switching time (100 micro-seconds), which would be difficult to achieve using relays (which stay on for tens of milliseconds). Also, such relays would readily degrade doing this kind of fast switching, and they would also make audible noise too. In contrast, the FETS operate with essentially no audible noise. Also provided is a combined temperature/humidity sensor module **1274**, such as a Sensirion SHT21 module. The backplate microcontroller **1262** performs polling of the various sensors, sensing for mechanical wire insertion at installation, alerting the head unit regarding current vs. setpoint temperature conditions and actuating the switches accordingly, and other functions such as looking for appropriate signal on the inserted wire at installation.

**[0203]** In accordance with the teachings of the commonly assigned U.S. Ser. No. 13/269,501, supra, the commonly assigned U.S. Ser. No. 13/275,307, supra, and others of the commonly assigned incorporated applications, the smart thermostat **102** (FIG. **1**) represents an advanced, multi-sensing, microprocessor-controlled intelligent or “learning”

thermostat that provides a rich combination of processing capabilities, intuitive and visually pleasing user interfaces, network connectivity, and energy-saving capabilities (including the presently described auto-away/auto-arrival algorithms) while at the same time not requiring a so-called “C-wire” from the HVAC system or line power from a household wall plug, even though such advanced functionalities can require a greater instantaneous power draw than a “power-stealing” option (i.e., extracting smaller amounts of electrical power from one or more HVAC call relays) can safely provide. By way of example, the head unit microprocessor **1202** can draw on the order of 250 mW when awake and processing, and an LCD module (not shown) can draw on the order of 250 mW when active. Moreover, the Wi-Fi module **1212** can draw 250 mW when active, and needs to be active on a consistent basis such as at a consistent 2% duty cycle in common scenarios. However, in order to avoid falsely tripping the HVAC relays for a large number of commercially used HVAC systems, power-stealing circuitry is often limited to power providing capacities on the order of 100 mW-200 mW, which would not be enough to supply the needed power for many common scenarios.

**[0204]** The smart thermostat **102** resolves such issues at least by virtue of the use of a rechargeable battery (or equivalently capable onboard power storage medium) that will recharge during time intervals in which the hardware power usage is less than what power stealing can safely provide, and that will discharge to provide the needed extra electrical power during time intervals in which the hardware power usage is greater than what power stealing can safely provide. In order to operate in a battery-conscious manner that promotes reduced power usage and extended service life of the rechargeable battery, the thermostat **1800** is provided with both (i) a relatively powerful and relatively power-intensive first processor (such as a Texas Instruments AM3703 microprocessor) that is capable of quickly performing more complex functions such as driving a visually pleasing user interface display and performing various mathematical learning computations, and (ii) a relatively less powerful and less power-intensive second processor (such as a Texas Instruments MSP430 microcontroller) for performing less intensive tasks, including driving and controlling the occupancy sensors. To conserve valuable power, the first processor is maintained in a “sleep” state for extended periods of time and is “woken up” only for occasions in which its capabilities are needed, whereas the second processor is kept on more or less continuously (although preferably slowing down or disabling certain internal clocks for brief periodic intervals to conserve power) to perform its relatively low-power tasks. The first and second processors are mutually configured such that the second processor can “wake” the first processor on the occurrence of certain events, which can be termed “wake-on” facilities. These wake-on facilities can be turned on and turned off as part of different functional and/or power-saving goals to be achieved. For example, a “wake-on-PROX” facility can be provided by which the second processor, when detecting a user’s hand approaching the thermostat dial by virtue of an active proximity sensor (PROX, such as provided by a Silicon Labs SI1142 Proximity/Ambient Light Sensor with I2C Interface), will “wake up” the first processor so that it can provide a visual display to the approaching user and be ready to respond more rapidly when their hand touches the

dial. As another example, a “wake-on-PIR” facility can be provided by which the second processor will wake up the first processor when detecting motion somewhere in the general vicinity of the thermostat by virtue of a passive infrared motion sensor (PIR, such as provided by a PerkinElmer DigiPyro PYD 1998 dual element pyrodetector). Notably, wake-on-PIR is not synonymous with auto-arrival, as there would need to be N consecutive buckets of sensed PIR activity to invoke auto-arrival, whereas only a single sufficient motion event can trigger a wake-on-PIR wake-up.

[0205] FIGS. 13A-13D illustrate various views of a smart hazard detector (e.g., smart hazard detector 104, FIG. 1) that may be used as part of a smart home environment 100, as previously described.

[0206] Specifically, FIG. 13A illustrates an assembled view of the smart hazard detector 104. FIG. 13A shows the mounting plate 1324, front casing 1326, and cover plate 1328 in an assembled configuration with the various other components contained within an interior space of smart hazard detector 104. These figures also show the plurality of holes or openings of cover plate 1328 forming a visually pleasing design that is viewable by occupant of a room within which the smart hazard detector 104 is mounted. The lens button 1332 is shown attached to the smart hazard detector 104 so as to be centrally positioned with respect to cover plate 1328. As briefly described, light ring 1342 may be used to provide a halo appearance of light around and behind lens button 1332. The assembled smart hazard detector 104 provides a compact yet multifunctional device.

[0207] FIG. 13B illustrates an exploded perspective views of the smart hazard detector 104. As shown in FIG. 13B, the smart hazard detector 104 includes a mounting plate 1324 that may be attached to a wall of the building or structure to secure the smart hazard detector 104 thereto. Smart hazard detector 104 also includes a back plate 1330 that may be mounted to the mounting plate 1324 and a front casing 1326 that may be coupled with or otherwise secured to back plate 1330 to define a housing having an interior region within which components of the smart hazard detector 104 are contained. A circuit board 1300 may be coupled with or attached to back plate 1330. Various components may be mounted on circuit board 1300. For example, a smoke chamber 1334 may be coupled with or mounted on circuit board 1300 and configured to detect the presence of smoke. In one embodiment, smoke chamber 1334 may be mid-mounted relative to circuit board 1300 so that air may flow into smoke chamber 1334 from a position above circuit board 1300 and below circuit board 1300. A speaker 1336 and alarm device (not number) may also be mounted on circuit board 1300 to audibly warn an occupant of a potential fire danger when the presence of smoke is detected via smoke chamber 1334. Other components, such as a motion sensor, carbon monoxide sensor, microprocessor, and the like may likewise be mounted on circuit board 1300 as described herein.

[0208] In one embodiment, a protective plate 1338 may be attached to or otherwise coupled with circuit board 1300 to provide a visually pleasing appearance to the inner components of smart hazard detector 104 and/or to funnel or direct airflow to smoke chamber 1334. For example, when a user views the internal components of smart hazard detector 104, such as through vents in back plate 1330, protective plate 1338 may provide the appearance of a relatively smooth surface and otherwise hide the components or circuitry of

circuit board 1300. Protective plate 1338 may likewise function to direct a flow of air from the vents of back plate 1330 toward smoke chamber 1334 so as to facilitate air flow into and out of smoke chamber 1334.

[0209] Smart hazard detector 104 may also include a battery pack 1340 that is configured to provide power to the various components of smart hazard detector 104 when smart hazard detector 104 is not coupled with an external power source, such as a 120 V power source of the home or structure. In some embodiments, a cover plate 1328 may be coupled with the front casing 1326 to provide a visually pleasing appearance to smart hazard detector 104 and/or for other functional purposes. In a specific embodiment, cover plate 1328 may include a plurality of holes or openings that allow one or more sensors coupled with circuit board 1300 to view or see through a surface of cover plate 1328 so as to sense objects external to smart hazard detector 104. The plurality of openings of cover plate 1328 may be arranged to provide a visually pleasing appearance when viewed by occupants of the home or structure. In one embodiment, the plurality of openings of cover plate 1328 may be arranged according to a repeating pattern, such as a Fibonacci or other sequence.

[0210] A lens button 1332 may be coupled with or otherwise mounted to cover plate 1328. Lens button 1332 may allow one or more sensors to view through the lens button 1332 for various purposes. For example, in one embodiment a passive IR sensor (not shown) may be positioned behind the lens button 1332 and configured to view through the lens button 1332 to detect the presence of an occupant or occupants within the home or structure. In some embodiments, lens button 1332 may also function as a button that is pressable by a user to input various commands to smart hazard detector 104, such as to shut off an alarm that is triggered in response to a false or otherwise harmless condition. Positioned distally behind lens button 1332 may be a light ring 1342 that is configured to receive light, such as from an LED, and disperse the light within ring 1342 to provide a desired visual appearance, such as a halo behind lens button 1332. Positioned distally behind light ring 1342 may be a flexible circuit board 1344 that includes one or more electrical components, such as a passive IR sensor (hereinafter PIR sensor), LEDs, and the like. Flexible circuit board 1344 (hereinafter flex ring 1344) may be electrically coupled with circuit board 1300 to communicate and/or receive instructions from one or more microprocessors mounted on circuit board (not shown) during operation of smart hazard detector 104.

[0211] Referring now to FIGS. 13C and 13D, illustrated are front and rear perspective views of a circuit board of a smart hazard detector (e.g., smart hazard detector 104, FIG. 1). Circuit board 1300 includes a main body 1302 having a front side or surface and a rear side or surface. As described herein, various electrical components are mounted on circuit board 1300. In some embodiments, these components may be mounted on the front surface of circuit board 1300, on the rear surface of circuit board 1300 opposite the front surface, or on both surfaces of the circuit board 1300. For example, in a specific embodiment one or more microprocessors and/or other processor related components may be mounted on the rear surface of circuit board 1300 facing a protective plate while one or more functional components (e.g. an alarm device, CO detector, speaker, motion sensors, Wi-Fi device, Zigbee device, Bluetooth device, and the like) are



mounted on a front surface of circuit board **1300** facing a room of the home or structure in which the smart hazard detector **104** is positioned. Other components may be mid-mounted relative to circuit board **1300** so that opposing surfaces are positioned on opposing sides of the circuit board **1300** as described herein. In some implementations, the circuit board **1300** includes one or more integrated circuits which include a combination of radios and transceivers. For example, in some implementations, a Wi-Fi device and a Bluetooth device of the smart hazard detector **104** comprise a single chip, wherein the Wi-Fi device and the Bluetooth device transmit and receive signals using a single antenna. Various implementations of transceivers (e.g., radios **940**, radios **950**) are described in greater detail with respect to FIGS. **9** and **14-15G**.

[**0212**] As shown in FIG. **13C**, in a specific embodiment the front surface of circuit board **1300** may include a CO detector **1304** that is configured to detect presence of carbon monoxide gas and trigger an alarm device **1306** if the carbon monoxide gas levels are determined to be too high. The alarm device **1306** (which can be a piezoelectric buzzer having an intentionally shrill or jarring sound) may likewise be mounted on the front surface of circuit board **1300** so as to face an occupant of the room in which the smart hazard detector **104** is positioned to alarm the occupant of a potential danger. Alarm device **1306** may be configured to produce one or more sounds or signals to alert the occupant of the potential danger. The front surface may further include an area **1308** in which a speaker (not shown) is positioned. The Speaker may be configured to provide audible warnings or messages to the occupant of the room. For example, the speaker may alert the occupant of a potential danger and instruct the occupant to exit the room. In some embodiments, the speaker may provide specific instructions to the occupant, such as an exit route to use when exiting the room and/or home or structure. Other messages may likewise be communicated to the occupant, such as to alert the occupant that the batteries are low, that CO levels are relatively high in the room, that the smart hazard detector **104** needs periodic cleaning, or alert the occupant of any other abnormalities or issues related to hazard detector **104** or components thereof.

[**0213**] Circuit board **1300** may also include one or more motion sensors mounted on the front surface thereof. The motion sensors may be used to determine the presence of an individual within a room or surrounding area of the smart hazard detector **104**. This information may be used to change the functionality of the smart hazard detector **104** and/or one or more other devices connected in a common network as described previously. For example, this information may be relayed to a smart thermostat to inform the thermostat that occupants of the home or structure are present so that the smart thermostat may condition the home or structure according to one or more learned or programmed settings. The smart hazard detector **104** may likewise use this information for one or more purposes, such as to quiet the alarm device (e.g. gesture hush) as described herein or for various other reasons.

[**0214**] In one embodiment, a first ultrasonic sensor **1320** and a second ultrasonic sensor **1322** may be mounted on the front surface of circuit board **1300**. The two ultrasonic sensors, **1320** and **1322**, may be offset axially so as to point in slightly different directions. In this orientation, each ultrasonic sensor may be used to detect motion of an

individual based on an orientation of the smart hazard detector **104** relative to the room and/or occupant. Detecting the motion of the individual may be used to quiet the alarm device as described herein (i.e., gesture hush) or for any other reason. In one embodiment, an axis of the first ultrasonic sensor **1320** may be oriented substantially outward relative to the smart hazard detector **104** while an axis of the second ultrasonic sensor **1322** is oriented an angle relative to the axis of the first ultrasonic sensor **1320**. The first ultrasonic sensor **1320** may sense motion of an individual when the smart hazard detector **104** is mounted on a ceiling of the home or structure. Because the first ultrasonic sensor **1320** is oriented substantially outward relative to the smart hazard detector **104**, the first ultrasonic sensor **1320** essentially looks straight down on individuals beneath the smart hazard detector **104**. The second ultrasonic sensor **1322** may similarly sense motion of the individual when the smart hazard detector **104** is mounted on a wall of the home or structure. Because the second ultrasonic sensor **1322** is oriented at an angle relative to the first ultrasonic sensor **1320** and the smart hazard detector **104**, the second ultrasonic sensor essentially looks downward toward the floor when the smart hazard detector **104** is mounted on a wall of the home or structure, rather than looking directly outward as the first ultrasonic sensor **1320**. In one embodiment, the angular offset of the two ultrasonic sensors may be approximately 30° or any other desired value.

[**0215**] In another embodiment, the two ultrasonic sensors, **1320** and **1322**, may be replaced by a single ultrasonic sensor that is configured to rotate within the smart hazard detector **104** so that the single ultrasonic sensor is capable of looking straight outward similar to the first ultrasonic sensor **1320** or capable of looking downward similar to the second ultrasonic sensor **1322**. The single ultrasonic sensor may be coupled to circuit board **1300** via a hinge that allows the ultrasonic sensor to rotate based on the orientation of the smart hazard detector **104**. For example, when the smart hazard detector **104** is mounted to a ceiling of the home or structure, gravity may orient the ultrasonic sensor so as to look straight downward; whereas when the smart hazard detector **104** is coupled to a wall of the home or structure, gravity may cause the ultrasonic sensor to rotate via the hinge and look downward toward a floor and relative to the smart hazard detector **104**. In another embodiment, a motor may be coupled with the single ultrasonic sensor so as to rotate the ultrasonic sensor based on the orientation of the smart hazard detector **104**. In this manner, the ultrasonic sensor may always point in a direction that is likely to detect motion of an individual within the room or space surrounding the smart hazard detector **104**. In yet another embodiment, the single ultrasonic sensor may have a wide field of view that is able to substantially accommodate both mounting positions of the two ultrasonic sensors, **1320** and **1322**.

[**0216**] As shown in FIGS. **13C** and **13D**, body **1310** of circuit board **1300** also includes a substantially centrally located aperture **1312** through which a smoke chamber is inserted so as to mid-mount the smoke chamber relative to the circuit board **1300**. Aperture **1312** may also include a pair of notches **1314** through which wires are inserted to electrically couple the smoke chamber with circuit board **1300**. As previously described, mid-mounting of the smoke chamber through an aperture **1312** allows smoke and air to enter the smoke chamber from both the front surface or side of circuit board **1300** and the rear surface or side of circuit

board **1300**. Various aspects of the electrical components on the circuit board **1300** are now described, the positions thereon of many of which will be apparent to the skilled reader in view of the descriptions herein and FIGS. **13C** and **13D**. Included on the circuit board **1300** can be several components, including a system processor, relatively high-power wireless communications circuitry and antenna, relatively low-power wireless communications circuitry and antenna, non-volatile memory, audio speaker, one or more interface sensors, a safety processor, safety sensors, alarm device **1306**, a power source, and powering circuitry. The components are operative to provide failsafe safety detection features and user interface features using circuit topology and power budgeting methods that minimize power consumption. According to one preferred embodiment, a bifurcated or hybrid processor circuit topology is used for handling the various features of the smart hazard detector **104**, wherein the safety processor is a relatively small, relatively lean processor that is dedicated to core safety sensor governance and core alarming functionality as would be provided on a conventional smoke/CO alarm, and wherein the system processor is a relatively larger, relatively higher-powered processor that is dedicated to more advanced features such as cloud communications, user interface features, occupancy and other advanced environmental tracking features, and more generally any other task that would not be considered a “core” or “conventional” safety sensing and alarming task.

[**0217**] By way of example and not by way of limitation, the safety processor may be a Freescale KL15 microcontroller, while the system processor may be a Freescale K60 microcontroller. Preferably, the safety processor is programmed and configured such that it is capable of operating and performing its core safety-related duties regardless of the status or state of the system processor. Thus, for example, even if the system processor is not available or is otherwise incapable of performing any functions, the safety processor will continue to perform its core safety-related tasks such that the smart hazard detector **104** still meets all industry and/or government safety standards that are required for the smoke, CO, and/or other safety-related monitoring for which the smart hazard detector **104** is offered (provided, of course, that there is sufficient electrical power available for the safety processor to operate). The system processor, on the other hand, performs what might be called “optional” or “advanced” functions that are overlaid onto the functionality of the safety processor, where “optional” or “advanced” refers to tasks that are not specifically required for compliance with industry and/or governmental safety standards. Thus, although the system processor is designed to interoperate with the safety processor in a manner that can improve the overall performance, feature set, and/or functionality of the smart hazard detector **104**, its operation is not required in order for the smart hazard detector **104** to meet core safety-related industry and/or government safety standards. Being generally a larger and more capable processor than the safety processor, the system processor will generally consume more power than the safety processor when both are active.

[**0218**] Similarly, when both processors are inactive, the system processor will still consume more power than the safety processor. The system processor can be operative to process user interface features and monitor interface sensors (such as occupancy sensors, audio sensors, cameras, etc.,

which are not directly related to core safety sensing). For example, the system processor can direct wireless data traffic on both high and low power wireless communications circuitry, access non-volatile memory, communicate with the safety processor, and cause audio to be emitted from the speaker. As another example, the system processor can monitor interface sensors to determine whether any actions need to be taken (e.g., shut off a blaring alarm in response to a user detected action to hush the alarm). The safety processor can be operative to handle core safety related tasks of the smart hazard detector **104**. The safety processor can poll safety sensors (e.g., smoke, CO) and activate alarm device **1306** when one or more of safety sensors indicate a hazard event is detected. The safety processor can operate independently of the system processor and can activate the alarm device **1306** regardless of what state the system processor is in. For example, if the system processor is performing an active function (e.g., performing a Wi-Fi update) or is shut down due to power constraints, the safety processor can still activate the alarm device **1306** when a hazard event is detected.

[**0219**] In some embodiments, the software running on the safety processor may be permanently fixed and may never be updated via a software or firmware update after the smart hazard detector **104** leaves the factory. Compared to the system processor, the safety processor is a less power consuming processor. Using the safety processor to monitor the safety sensors, as opposed to using the system processor to do this, can yield power savings because safety processor may be constantly monitoring the safety sensors. If the system processor were to constantly monitor the safety sensors, power savings may not be realized. In addition to the power savings realized by using safety processor for monitoring the safety sensors, bifurcating the processors can also ensure that the safety features of the smart hazard detector **104** always work, regardless of whether the higher level user interface works. The relatively high power wireless communications circuitry can be, for example, a Wi-Fi module capable of communicating according to any of the 802.11 protocols.

[**0220**] By way of example, the relatively high power wireless communications circuitry may be implemented using a Broadcom BCM43362 Wi-Fi module. The relatively low power wireless communications circuitry can be a low power Wireless Personal Area Network (6LoWPAN) module or a ZigBee module capable of communicating according to an IEEE 802.15.4 protocol. For example, in one embodiment, the relatively low power wireless communications circuitry may be implemented using an Ember EM357 6LoWPAN module. The non-volatile memory can be any suitable permanent memory storage such as, for example, NAND Flash, a hard disk drive, NOR, ROM, or phase change memory. In one embodiment, the non-volatile memory can store audio clips that can be played back using the speaker **1336**. The audio clips can include installation instructions or warning in one or more languages. The interface sensors can include sensors that are monitored by system processor, while the safety sensors can include sensors that are monitored by the safety processor. Sensors can be mounted to a printed circuit board, a flexible printed circuit board, a housing of a system, or a combination thereof.

[**0221**] The interface sensors can include, for example, an ambient light sensor (ALS) (such as can be implemented

using a discrete photodiode), a passive infrared (PIR) motion sensor (such as can be implemented using an Excelitas PYQ1348 module), and one or more ultrasonic sensors (such as can be implemented using one or more Manorshi MS-P1640H12TR modules). The safety sensors can include, for example, the smoke detection chamber 1334 (which can employ, for example, an Excelitas IR module), the CO detection module 1304 (which can employ, for example, a Figaro TGS5342 sensor), and a temperature and humidity sensor (which can employ, for example, a Sensirion SHT20 module). The power source can supply power to enable operation of the smart hazard detector and can include any suitable source of energy. Embodiments discussed herein can include AC line powered, battery powered, a combination of AC line powered with a battery backup, and externally supplied DC power (e.g., USB supplied power). Embodiments that use AC line power, AC line power with battery backup, or externally supplied DC power may be subject to different power conservation constraints than battery only embodiments.

[0222] Preferably, battery-only powered embodiments are designed to manage power consumption of its finite energy supply such that smart hazard detector 104 operates for a minimum period of time of at least seven (7), eight (8), nine (9), or ten (10) years. Line powered embodiments are not as constrained. Line powered with battery backup embodiments may employ power conservation methods to prolong the life of the backup battery. In battery-only embodiments, the power source can include one or more batteries. The batteries can be constructed from different compositions (e.g., alkaline or lithium iron disulfide) and different end-user configurations (e.g., permanent, user replaceable, or non-user replaceable) can be used. In one embodiment, six cells of Li—FeS<sub>2</sub> can be arranged in two stacks of three. Such an arrangement can yield about 27000 mWh of total available power for the smart hazard detector 104.

[0223] FIG. 14 illustrates a block diagram of a communications module 942 of a smart device utilizing bypass circuitry, in accordance with some implementations. FIG. 14 illustrates a communications module 942 of a smart device 204 (e.g., FIG. 9), in accordance with any of the implementations disclosed in FIGS. 1-9 (e.g., devices 102, 104, 106, 108, 110, 112, 114, 116, 118, 120, and/or 122, FIG. 1, such as a camera 118, a smart hazard detector 104, a smart thermostat 102, etc.).

[0224] In some implementations, the communications module 942 includes one or more radios 940, radios 950, a front end module 1400, and antennas 1402. In some implementations, the one or more radios 940 and radios 950 are communicably connected, and each have respective antennas 1402 through which respective signals are transmitted and received. As an example, the communications module 942 of a camera 118 includes a first transceiver for transmitting video data (e.g., Wi-Fi, radios 950), and additionally includes a second transceiver for transmitting and receiving packets from other smart devices in a smart home environment (e.g., Zigbee, radios 940). Optionally, a combined transceiver is configured for transmitting and receiving data in accordance with more than one communications protocol (e.g., radio 950 configured for Wi-Fi and Bluetooth LE). Components of the communications module 942 (e.g., radios 940, radios 950) are described in greater detail with regards to FIG. 9.

[0225] The front end module 1400 of the communications module 942 includes a variety of circuit elements for manipulating (e.g., amplifying) signals received and transmitted by the radios 940. In particular, the front end module 1400 includes switches 1404 for coupling the radios 940 and the antenna 1402 by selectively using an amplifier (e.g., amplifier 1406-1 and a low noise amplifier 1406-2) or bypass line 1408. Whether the front end module 1400 couples the radios 940 and the antenna 1402 by the low noise amplifier 1406-2 or the bypass line 1408 depends on whether the radio 950 is active and transmitting signals using the second antenna 1402-2. Although not illustrated, other implementations of the front end module 1400 may include additional circuit elements, including one or more additional switches, amplifiers, transistors, and/or any combination of active or passive elements. A combination of circuit elements may be used in the front end module 1400, for example, to modify the sensitivity of the communications module 942 and signals transmitted and/or received through the radios 940.

[0226] As described previously, poor signal isolation typically results from the close physical placement of antennas 1402. In particular, device components risk damage in the event that the signal power of transmitting antennas in a transmission chain nearby (e.g., antenna 1402-2 for Wi-Fi transmissions) exceeds the maximum input power of components in the receiving chain (e.g., 802.15.4 receiving chain formed by radio(s) 940 and antenna 1402-1).

[0227] One method for enabling and enhancing coexistence of transceiver devices (e.g., radios 940, radios 950) includes the use of a bypass line 1408 in a front end module 1400. In particular, by using the switches 1404 to automatically and selectively enable the bypass line 1408 when the radio 950 (e.g., Wi-Fi) is “on” and transmitting signals through the antenna 1402-2 (e.g., radios 950 signals to the front end module 1400 through connection 1410 that it is “on” and transmitting), transmissions received through the antenna 1402-1 do not pass through the low noise amplifier 1406-2, and instead pass through the bypass line 1408 to the radios 940. Consequently, the effective maximum input power that can be tolerated by the front end module 1400 may be increased (i.e., the front end module 1400 has a larger input power threshold when the bypass line 1408 is used to couple the radio 940 and the antenna 1402-1), as determined by characteristics of the bypass line 1408, rather than the low noise amplifier 1406-2. When the radio 950 is “off,” the switches 1404 operate to couple the radios 940 and the antenna 1402-1 with the low noise amplifier 1406-2 in the receiver pathway. Thus, with respect to receiver chain sensitivity, the front end module 1400 has a higher receiver sensitivity when the low noise amplifier 1406-2 is used to couple the radio 940 and the antenna 1402-1. Given the selective operation of the low noise amplifier 1406-2 based on the activity of the radio 950, the risk of damage to the low noise amplifier 1406-2 is avoided, while still achieving improved sensitivity through the use of the low noise amplifier 1406-2. Therefore, the front end module 1400 is configured to couple the antenna 1402-1 to the radio 940 via the bypass line 1408 when the radio(s) 950 is active and transmitting signals using the antenna 1402-2 such that a signal received via the antenna 1402-1 is not amplified by the amplifier 1406-2 prior to being passed to the radio 940. The front end module 1400 is further configured to couple the antenna 1402-1 to the radio 940 via the amplifier 1406-2

when the radio(s) **950** is not transmitting signals using the antenna **1402-2** such that a signal received via the antenna **1402-1** is amplified by the amplifier **1406-2** prior to being passed to the radio **940**. Methods of coexistence using the bypass circuitry in FIG. **14** is described in greater detail with respect to FIG. **22**.

[**0228**] FIGS. **15A-15G** illustrate a coexistence scheme for a smart device having multiple radios in smart home environment **100**, in accordance with some implementations.

[**0229**] As illustrated in FIG. **15A**, a smart device **204** (e.g., a camera **118**) transmits data to and receives data from other devices in proximity (e.g., smart hazard detector **104**, camera **118**, smart thermostat **102**). Simultaneously, data (e.g., live video stream recorded by the camera **118**) is transmitted to and from a remote server system over a network (e.g., a smart home provider server system **164**, over the network **162** through a network interface **160**). In some implementations, the various devices in the smart home environment **100** are also communicably connected and may therefore transmit/receive data from one another. The specific smart devices illustrated and described in FIG. **15A** are merely examples, and other implementations include various combinations of smart devices (not illustrated).

[**0230**] In some implementations, a camera **118** (or any smart device **204** that provides high bandwidth output data) needs to transmit one more video streams at different resolutions (e.g., 180p, 780p and 1080p) to the server system **164** for additional processing, storage, and/or sharing with authorized users. In some situations, as when the video stream is a live, high definition (e.g., 780p or 1080p) video stream, this requires the camera **118** to maintain a low latency, high bandwidth connection to the server system **164** through the network interface **160** for a substantial period of time (e.g., from a few minutes to hours). This is accomplished in some implementations by the camera **118** employing a Wi-Fi connection provided by the network **162** to connect to the server system **164** to transmit video streams. At the same time, the camera **118** needs to be responsive to high priority alerts from other smart devices **204** so these alerts can be processed locally (e.g., used to change system state in the camera **118**, transmitted to a hub device **180** for integration processing in view of other system alerts and status information, relayed to other smart home devices **204**, or transmitted to client devices **504** that are configured to issue alerts directed to authorized users) and/or transmitted to the server system **164**. In some implementations, these alerts are issued via Bluetooth or IEEE 802.11.15.4 signals by radios in other smart devices **204** (such as a smart hazard detector **304**) and are received by corresponding radios in the camera **118** (or any comparable smart device **204**). These alerts are typically of short duration and low bandwidth in contrast to streaming video, which is long duration and high bandwidth. In some implementations, these alerts need to be retransmitted to other smart devices **204** by the corresponding Bluetooth or IEEE 802.11.15.4 radios in the camera **118** (or any comparable smart device **204**), which operate at the same frequency as the Wi-Fi radio (e.g., 2.4 GHz). This requires the camera **118** to prioritize use of the radios and antennas such that high priority transmissions received from other smart devices **204** (e.g., smoke or CO alerts) are transmitted with minimal latency, while during normal operation (e.g., when there are no incoming alerts from other smart devices **204**), video streaming is enabled with high efficiency through the Wi-Fi radio. Devices with multiple

radios (e.g., Wi-Fi, Bluetooth, and 802.11.15.4) may be utilized in a number of additional ways. In some embodiments, for example, one or more radios of a device may be used for secure device provisioning (e.g., via Bluetooth). Additionally, as described above, one or more radios may also be used for low-power communications (e.g., in devices not connected to a persistent power source).

[**0231**] Any of the operations described above in which multiple radios are utilized require a co-existence strategy, described herein, that manages the use by multiple radios (e.g., 2 or more) of one or more antennas with poor isolation from each other to transmit without interference signals at the same frequency or frequencies that would otherwise interfere.

[**0232**] In different implementations, a smart device **204** can be any sort of home automation device that employs multiple radios for a variety of purposes, including purposes similar to those described herein (e.g., a Wi-Fi radio to stream data to a cloud service or with a local network, a Bluetooth radio for configuration purposes, and an IEEE 802.11.15.4 radio to enable communications with other home automation devices in smart devices in a smart home environment to, or purposes that differ in one or more ways from those purposes (e.g., without limitation, a Wi-Fi radio used to exchange data, alerts, and/or control commands with, and/or monitor communication status of, other smart home automation devices, a Bluetooth radio used to exchange data, alerts, and/or control commands with, and/or monitor communication status of, other smart home automation devices; and an IEEE 802.11.15.4 radio used to transmit remote control commands and occupant presence information from one home automation device to another). For example, the smart device **204** can be a smart/connected appliance, such as a refrigerator, washing machine, dryer, or dishwasher; a home entertainment device, such as a television, digital video recorder, audio/visual receiver, connected speaker, or media projector; a home networking device, such as a network router, switch or network attached storage; a home security/access device, such as a connected door lock, garage door controller, or doorbell with integrated security camera or hazard detector; indoor and/or outdoor home lighting devices; landscape irrigation devices and controllers; automated home window coverings and/or skylights; and heating and cooling systems.

[**0233**] Each of the home automation devices **204** has specific features (e.g., end user features, operating features and/or network/collaboration features) based upon its type and purpose, and includes electronic and electromechanical components that can be controlled and/or automated to further the purposes/uses of a home automation environment and/or of the respective automation device. For example, a particular smart refrigerator with a rich set of connected features (i.e., features controllable via various network connections to other smart home devices and/or to applications running on end user devices—such as smart phones, tablets, laptops or desktop) might have a compressor, ice cube maker, internal and exterior lighting, freezer section, refrigerator section, external display panel, processor, audio recorder/microphone, video camera, memory, proximity sensor and three different radios, all of which support one or more of inter-device communications and/or data streaming. Given a refrigerator configured as described above, in some implementations, temperature of the freezer and refrigerator sections, ice maker operation, etc. can be controlled over

Wi-Fi, Bluetooth or IEEE 802.11.15.4 connections, refrigerator performance data and recorded and/or live audio and video can be sent over the Wi-Fi connection, and status and presence messages and alerts can be exchanged with other home automation devices using IEEE 802.11.15.4 connections. As another example, given a landscape irrigation controller with Wi-Fi, Bluetooth and IEEE 802.11.15.4 radios, the controller can transmit irrigation commands (e.g., ON and OFF) consistent with irrigation programs to outdoor sprinklers using IEEE 802.11.15.4 connections, obtain weather information (such as temperature and predicted precipitation from the Internet and/or local smart home automation devices—e.g., an outdoor moisture detector—via the Wi-Fi connection, and can accept operating and configuration commands from a smart phone running an corresponding irrigation app using Bluetooth or Wi-Fi connections. In these example implementations and other similar implementations, the multiple radios and their respective antennas are located in accordance with antenna placement principles described herein and the multiple radios are configured to co-exist (i.e., cooperatively transmit and receive over their associated antennas) using co-existence principles and signals described herein.

[0234] As shown in FIG. 15A, some implementations of a communications module 942 include one or more radios 940, radios 950, antennas 1402, an optional front end module 1400 (as described in FIG. 14), and one or more control lines 1500 which transmit signals between the one or more radios 940 and radios 950 (e.g., RADIO\_PRI on control line 1500-1, RADIO\_REQ on control line 1500-2, and WIFI\_GRANT on control line 1500-3). Various components of the communications module 942 are described in greater detail with respect to FIGS. 9 and 14.

[0235] In some implementations, the control lines 1500 are used to transmit control signals between one or more radios 940 and radios 950 to manage the operation of transceiver devices in accordance with a coexistence scheme. In particular, as described in greater detail below, control signals are transmitted as a means for indicating and determining a priority of signals being transmitted by the one or more radios 940 and radios 950. A transceiver determined to have a lower priority yields to a higher priority transceiver by suspending transmissions for a duration of time as the higher priority transceiver completes transmitting/receiving data, thus lessening or altogether avoiding the negative effects of poor isolation resulting from transceiver devices operating simultaneously. As an example, when the RADIO\_PRI (i.e., request for transmission priority) and RADIO\_REQ (e.g., request for transmission) control lines 1500-1 and 1500-2 are asserted by the radios 940, the radio 950 yield to transmission requests by the radios 940 by suspending its own transmissions while the radios 940 transmit/receive data. Referring to the example in FIG. 15A, when the RADIO\_PRI and RADIO\_REQ control lines 1500-1 and 1500-2 are asserted, the radio 950 of the smart device 204 (e.g., Wi-Fi transceiver of a camera 118) momentarily suspend uploads of recorded video to the smart home provider server system 164, while permitting the radios 940 (e.g., 802.15.4) to transmit critical packets received from a smart hazard detector 104 to a smart thermostat 102 by activating (or “asserting”) the WIFI\_GRANT control signal. As a result, interference and transmission collisions are avoided between the transceiver devices, while reducing the risk of damaging hardware

components (e.g., by exceeding device input power thresholds) and failing to transmit critical data (e.g., emergency pings from a smart hazard detectors 104).

[0236] In some implementations, one of the transceivers serves as a “master” device which receives requests for transmissions and moderates transmissions between itself and requesting transceivers. In the example shown, the radio 950 (e.g., Wi-Fi transceiver) is the master, as indicated by the directions of the control lines 1500 (i.e., with respect to the radio 950, WIFI\_GRANT is an output, and RADIO\_PRI and RADIO\_REQ are inputs).

[0237] The radios 940 and/or the radios 950 may operate in station mode (i.e., transceiver acts as a client that connects to an access point, such as a router), Access Point (AP) mode (i.e., transceiver acts as an access point through which other devices can connect and access other connected devices), and/or Ad-Hoc mode (e.g., mode in which network connected devices have equal status and may associate with any other network device in range). Furthermore, radios 940 and/or the radios 950 may operate in a variety of power modes (e.g., full power mode, power save mode). In the example coexistence scheme of FIGS. 15A-15G, the radio 950 (e.g., Wi-Fi) operates in station mode and full power mode. Furthermore, in the given example, the WIFI\_GRANT control signal is kept activated when the radio 950 is in power save mode.

[0238] Although the example illustrates the use of three control lines, other implementations may include additional control lines and control signals for determining a request priority of a transmitting device. Additional control lines and control signals may, for example, be used in implementations which include two or more radios 940 or radios 950 in a combined device (e.g., a combined Bluetooth and 802.15.4 chip), such that the plurality of transceiver devices can separately arbitrate with the master device.

[0239] Alternatively, in some implementations, two or more radios 940 or radios 950 are integrated as a combined device (e.g., a combined Bluetooth and Wi-Fi 802.11 chip), and a separate arbitration scheme may be implemented such that the two radios 940 or radios 950 arbitrate internally before arbitrating with the other transceiver of the communications module 942. FIG. 15B illustrates an example of an internal arbitration scheme between transceivers combined in a single device (e.g., Bluetooth and Wi-Fi transceivers combined in a single device, shown by radios 950-1 and 950-2, respectively). Using a switch 1404-3, for example, radios 950-1 and 950-2 decide between each other (e.g., based on instructions and logic in the firmware of radio 950-1 and/or 950-2) as to which transceiver will have control over the antenna 1402-2. Thus, the example coexistence scheme of FIG. 15A operates independently from, but simultaneously with, any internal coexistence schemes implemented between radios 940 or radios 950 (e.g., coexistence scheme involving 802.15.4 and Wi-Fi is independent from internal coexistence scheme involving Wi-Fi and Bluetooth).

[0240] While reference is made with respect to 802.15.4 and Wi-Fi, other implementations may include any combination of other transmission protocols described with respect to FIGS. 9 and 14.

[0241] FIG. 15C illustrates a table of example control signal assignments. As described above, the example coexistence scheme of FIGS. 15A-15G uses three signals, RADIO\_REQ (input), RADIO\_PRI (input) and WIFI\_

GRANT (output). These control signals may be assigned to various physical pins of the radios **940** and radio **950** (e.g., pins L6, L7, and L8).

**[0242]** Coexistence schemes may be configured and implemented with any signal polarity (High-Active or Low-Active). In the example shown, the signal polarity is assumed to be Low-Active. In some implementations, control signals and control lines **1500** are assigned to physical pins of the transceivers, and are therefore handled by on-chip target firmware. Thus, control signals do not directly control the transceivers (e.g., to stop/resume Wi-Fi transmission), but rather operate through logic implemented by device firmware.

**[0243]** The use of these control signals are configured such that the radio **940** and radio **950** can support two modes of operation: a “normal” and “alarming” mode.

**[0244]** In the “normal” mode, the radio **940** (e.g., 802.15.4) operates asynchronously. That is, the radio **940** can request transmission access at any time. In this mode, the priority pin (e.g., RADIO\_PRI) will not be asserted. Furthermore, the radio **950** (e.g., Wi-Fi) is permitted (although not required) to complete existing packet transmissions before granting transmission requests to the radio **940** (i.e., asserting WIFI\_GRANT).

**[0245]** In “alarming” mode (or “high priority” mode), the radio **940** (e.g., 802.15.4) requests access in a periodic fashion. As an example, the radio **940** requests for a 900 us transmission period every 4 ms. The priority control signal (e.g., RADIO\_PRI) will be asserted during this entire period and can be used by the radio **950** (e.g., Wi-Fi) to infer the mode. In some implementations, in the alarming mode, the radio **940** and the radio **950** operate synchronously. That is, transmissions from the radio **950** (e.g., Wi-Fi) are timed with the falling (or rising) edge of the RADIO\_REQ control signal. By synchronously timing the assertion and de-assertion of the RADIO\_REQ control signal, minimum timing guarantees can be created with respect to transmission access for the radio **950**. This is in contrast to “normal mode,” where a looser coupling exists between transmissions between radio(s) **940** and radio(s) **950**, where transmission access is granted/denied in an ad hoc fashion.

**[0246]** Implementations of the various controls signals for supporting these modes of operation are described below.

**[0247]** In some implementations, the RADIO\_REQ control signal (e.g., control line **1500-2**, FIG. **15A**) is a transmission request signal from the radios **940** (e.g., 802.15.4 transceiver). When the radio **950** (e.g., Wi-Fi transceiver) detects this signal, it attempts to suspend its transmissions and simultaneously activates the WIFI\_GRANT control signal (e.g., control line **1500-3**, FIG. **15A**), indicating that its transmission has stopped and that the radios may begin transmission (e.g., on a shared 2.4 GHz frequency band).

**[0248]** In some implementations, the RADIO\_PRI control signal (e.g., control line **1500-1**, FIG. **15A**) is signal from the radios **940** (e.g., 802.15.4) indicating an importance of the transmission request. Thus, if RADIO\_PRI is active when RADIO\_REQ is detected, the radio **950** (e.g., Wi-Fi) will treat it as “high priority” request. Consequently, the radio **950** attempts to shut down its transmissions as soon as possible, activates the WIFI\_GRANT control signal, and does not revoke the WIFI\_GRANT control signal until RADIO\_REQ is deactivated.

**[0249]** If RADIO\_PRI is inactive when RADIO\_REQ is detected, the radio **950** will treat it as “regular priority”

request. Thus, if an important operation by the radio **950** is in progress (e.g., scheduled beacon receive), the WIFI\_GRANT control signal will not be activated until that operation is completed. Furthermore, if the WIFI\_GRANT control signal is already activated when the RADIO\_REQ control signal is also activated, WIFI\_GRANT will be revoked (deactivated) if and when the radio **950** seeks to access to the radio.

**[0250]** The RADIO\_PRI control signal is checked when the radio **950** (e.g., Wi-Fi transceiver) detects a change of the RADIO\_REQ control signal (e.g., activation/inactivation). The RADIO\_PRI control signal level must be established a time T\_PRI\_SETUP before changing the RADIO\_REQ control signal. When the RADIO\_REQ control signal is still activated when the RADIO\_PRI control signal is activated, it triggers an “alarming” mode to the radio **950**, forcing a “slotted” mode operation. The slotted mode is implemented in order to respond rapidly during a RADIO\_REQ interval in high priority mode (“alarming mode,” an example of which is described with respect to FIG. **15G**). In slotted mode, a TX Request Descriptor is placed in the hardware queue only upon inactivation of the RADIO\_REQ control signal. The transmission throughput of the radio **950** (e.g., Wi-Fi) in slotted mode is limited to a single packet in every RADIO\_REQ interval. Thus, only a single Wi-Fi packet is sent every time when the RADIO\_REQ control signal is inactivated. In some implementations, when switching from alarming mode to normal mode, the RADIO\_PRI must be inactivated when RADIO\_REQ is inactivated. Assuming 1440 Bytes/packet and a 4 ms RADIO\_REQ interval, transmission throughput of the radio **950** under alarming mode is 2.7 Mbit/sec. In addition, Wi-Fi retry limit is set to 3 in slotted mode, where default retry limit is 15.

**[0251]** The WIFI\_GRANT control signal is provided by the radio **950** (e.g., Wi-Fi), which, when activated, indicates that the transmission activity of the radio **950** was ceased, and that the radios **940** (e.g., 802.15.4 transceiver) may use the frequency band for transmission (e.g., 2.4 GHz band).

**[0252]** Furthermore, in order to achieve quick pause-resume of transmissions by a Wi-Fi transceiver, in some implementations 802.11n sub-frame aggregation is disabled. Furthermore, in some implementations, the number of TX Request Descriptors placed in the hardware transmission queue is limited to 1. As a result, the transmission throughput of the Wi-Fi transceiver, for example, is reduced about 10 Mbps even when connected to an 802.11n access point.

**[0253]** In some implementations, a camera device (e.g., smart device **204** in FIG. **15A**, which is a camera) includes a first and second antenna (e.g., antennas **1402-1** and **1402-2**, respectively), and a first (e.g., radio **950-1**, FIG. **15B**), second (e.g., radio **940**, FIG. **15A**), and third transceiver (e.g., radio **950-2**, FIG. **15B**). The second transceiver is coupled to the first antenna (e.g., radio **940** coupled to antenna **1402-1**), and the first and third transceivers are coupled to the second antenna (e.g., radios **950-1** and **950-2** coupled to antenna **1402-2**, FIG. **15B**). In some implementations, the first transceiver is configured to transmit and receive, over a first one of a plurality of distinct communication protocols, signals for configuring the camera device (e.g., Bluetooth Low Energy), the second transceiver is configured to transmit and receive, over a second one of the plurality of distinct communication protocols, signals comprising one or more of alerts, control signals and status information to and from the one or more smart home devices

(e.g., 802.15.4), and the third transceiver is configured to transmit and receive, over a third one of the plurality of distinct communication protocols, data corresponding to video captured by the camera device (e.g., Wi-Fi). In some implementations, the second transceiver and the first and/or third transceivers are coupled by a plurality of control lines for selectively granting or denying transmission access to the first, second, and third transceivers (e.g., control lines 1500, FIG. 15A). In some implementations, the first transceiver and the third transceiver comprise a single combined transceiver (e.g., radio 950, which includes radio 950-1 and radio 950-2, FIG. 15B), and the second transceiver is coupled to the single combined transceiver by the plurality of control lines (e.g., radio 940 and radio 950 coupled by control lines 1500, FIG. 15A).

[0254] In some implementations, the plurality of control lines include a first control line for a priority control signal (e.g., RADIO\_PRI on control line 1500-1, FIG. 15A), a second control line for a radio request control signal (e.g., RADIO\_REQ on control line 1500-2), and a third control line for granting or denying transmission access to the second transceiver or the third transceiver (e.g., WIFI\_GRANT on control line 1500-3). Transmission access is granted or denied to the second transceiver or the third transceiver using the third control line in accordance with detection of an activated or deactivated priority control signal, an activated or deactivated radio request control signal, and/or a transmission request by the third transceiver. In some implementations, transmission access is granted to the second transceiver and denied to the third transceiver if an activated priority control signal is detected on the first control line and an activated radio request control signal is detected on the second control line; or a deactivated priority control signal is detected on the first control line and the activated radio request control signal is detected on the second control line, but the transmission request by the third transceiver is not detected. In some implementations, transmission access is denied to the second transceiver and granted to the third transceiver if an activated priority control signal is detected on the first control line, a transmission request by the third transceiver is detected, and a deactivated radio request control signal is detected on the second control line; or a deactivated priority control signal is detected on the first control line and the transmission request by the third transceiver is detected. Granting and denying of transmission access to the first transceiver, the second transceiver, and/or the third transceiver is described in greater detail with respect to FIGS. 23A-23F.

[0255] FIGS. 15D-15G illustrate various signal timing diagrams and timing charts for various modes of operation in a coexistence scheme, in accordance with some implementations. As stated previously, in the examples shown and described with respect to FIG. 15D-15G, the signal polarity of the control signals is Low-Active (i.e., control signal is considered “active” when low), although control signals may be configured in other implementations to have a High-Active polarity. Furthermore, the timing charts illustrated in FIGS. 15D-15G are merely examples of timing requirements (e.g., minimum/maximum requirements) for an example coexistence scheme, and in other implementations, the communications module 942 of a smart device (e.g., camera 118, smart hazard detector 104, smart thermo-

stat 102, etc.), and components thereof (e.g., radios 940, radios 950), are configured to satisfy other predefined timing requirements.

[0256] In particular, FIGS. 15D-1 and 15D-2 illustrate a signal timing diagram and timing chart for a normal mode of operation for a coexistence scheme, in accordance with some implementations.

[0257] As shown in FIG. 15D-1, even if the RADIO\_PRI control signal is activated, the WIFI\_GRANT control signal is not asserted until the RADIO\_REQ control signal is activated. As shown in the timing chart of FIG. 15D-2, T\_PRI\_SETUP is the setup time between asserting RADIO\_PRI and asserting RADIO\_REQ. Moreover, T\_REQ\_LATENCY is the latency between asserting RADIO\_REQ and asserting WIFI\_GRANT. The T\_REQ\_LATENCY time is defined by requirements of the radios 940 (e.g., 802.15.4 radio requirement) and implementation limitations of the radio 950 (e.g., Wi-Fi). In some implementations, the T\_REQ\_LATENCY time is mainly general-purpose I/O (GPIO) interrupt latency plus the TX DMA stop latency (e.g., a maximum of 3.5 msec). The WIFI\_GRANT control signal could be further delayed, however, for beacon protection (described in greater detail with respect to FIGS. 15F-1 and 15F-2).

[0258] Furthermore, as shown in FIG. 15D-1, when both the RADIO\_PRI control signal and the RADIO\_REQ are deactivated, the WIFI\_GRANT is revoked. The T\_REVOKE\_LATENCY time is the latency between de-asserting RADIO\_REQ and de-asserting WIFI\_GRANT.

[0259] Additional timing metrics include T\_REQ\_PERIOD, which is the length of time for which the RADIO\_REQ control signal is asserted. In some implementations, T\_REQ\_PERIOD is defined from requirements of the radios 940 (e.g., 802.15.4 radio requirement) and throughput/connection stability of the radio 950 (e.g., Wi-Fi). Furthermore, T\_REQ\_INTERVAL is defined as the interval of time between asserting the RADIO\_REQ control signal.

[0260] FIGS. 15E-1 and 15E-2 illustrate a signal timing diagram and timing chart for a mode of operation in a coexistence scheme in which a request grant is revoked based on predefined performance requirements, in accordance with some implementations.

[0261] In particular, the signal timing diagram of FIG. 15E-1 illustrates a signal timing diagram in which the WIFI\_GRANT control signal is revoked in accordance with Quality of Service (QoS) requirements. In the example provided, when RADIO\_PRI is not asserted, WIFI\_GRANT will be revoked when there is a high priority transmission request by the radio 950 (e.g., Wi-Fi), even if the RADIO\_REQ control line is still asserted. In some implementations, a “High priority” transmission request is considered to be within an Access Category (AC) that is above BE (Best Effort), VI (Video) and/or VO (Voice), respectively. For example, management frames are considered to be the same priority as VO (Voice).

[0262] FIG. 15E-2 illustrates a timing chart in which WIFI\_GRANT is revoked in accordance with QoS requirements. As the RADIO\_PRI control signal is assumed to be de-asserted, this example pertains only to a non-priority coexistence request.

[0263] As shown in FIG. 15E-1, if a “high priority” transmission occurs, WIFI\_GRANT will be revoked even if the RADIO\_REQ control signal is asserted. The time T\_REVOKE\_LEAD\_Q is defined as the lead period between

de-asserting the WIFI\_GRANT and the “high priority” Wi-Fi transmission. Furthermore, the time  $T\_WIFI\_ACT$  is the duration of time of the high priority Wi-Fi transmission.

[0264] When the high-priority transmission ceases, WIFI\_GRANT is re-asserted, the amount of time between such occurrences being defined by  $T\_REGRANT\_LATENCY\_Q$ .

[0265] Other timing metrics include  $T\_GRANT\_MIN\_Q$ , which is the minimum amount of time for which WIFI\_GRANT can be guaranteed to be asserted. In some implementations, because transmission activity of the radio 950 (e.g., Wi-Fi) is asynchronous to a request signal from the radios 940 (e.g., 802.15.4), a minimum WIFI\_GRANT period (e.g., time  $T\_GRANT\_MIN\_Q$ ) is not guaranteed.

[0266] Furthermore,  $T\_WIFI\_IDLE$  is defined as the interval of time between high-priority transmission requests.

[0267] FIGS. 15F-1 and 15F-2 illustrate a signal timing diagram and timing chart for a mode of operation for a coexistence scheme utilizing beacon protection, in accordance with some implementations.

[0268] FIG. 15F-1 illustrates a timing chart with beacon protection. When RADIO\_PRI is not asserted, WIFI\_GRANT will be revoked in order to avoid interference with incoming beacons received by the radio 950 (e.g., Wi-Fi beacons). As the RADIO\_PRI control signal is assumed to be de-asserted, this example pertains only to a non-priority coexistence request.

[0269] As shown, if a beacon transmission occurs, WIFI\_GRANT will be revoked even if the RADIO\_REQ control signal is asserted.

[0270]  $T\_GRANT\_MIN$  is defined as a minimum period of time for which WIFI\_GRANT can be guaranteed to be asserted before being revoked by a beacon transmission.  $T\_REVOKE\_LEAD$  is defined as a lead period between WIFI\_GRANT being de-asserted and the time at which a beacon is scheduled to be received at the radio 950.  $T\_GRANT\_MIN$  and  $T\_REVOKE\_LEAD$  are defined from requirements of the radios 940 (e.g., 802.15.4 radio requirement). Furthermore, in some implementations, the radio 950 (e.g., Wi-Fi transceiver) can be programmed to have timer control up to a precision of 1 ms.

[0271]  $T\_BEACON\_ACT$  is the period of time a beacon is received by the radio 950 (e.g., a Wi-Fi beacon) and is defined as how long a beacon signal can be. WIFI\_GRANT would not be re-asserted by timeout while the radio 950 is still receiving a beacon. As an example, for a 2.4 GHz beacon sent at a 1 Mbps DSSS rate, given a typical beacon frame of approximately 300 Bytes,  $T\_BEACON\_ACT$  is defined to be approximately  $300 \times 8 \times 1$  us, or 2.4 ms.

[0272]  $T\_BEACON\_INT$  is defined as an interval of time for the beacon. In some implementations,  $T\_BEACON\_INT$  is defined as  $T\_GRANT\_MIN + T\_REVOKE\_LEAD$ .

[0273] In some implementations, the beacon interval  $T\_BEACON\_INT$  is defined by the Access Point to which the radio 950 is connected. As an example, the default beacon interval of an Access Point is 100 TUs (or 102.4 ms).

[0274] FIG. 15F-3 illustrates an example of a signal timing diagram with beacon skipping. When RADIO\_REQ is asserted without RADIO\_PRI at a time that is too close to receiving the next scheduled beacon, WIFI\_GRANT is asserted only after the scheduled beacon has been received and completed. In this case,  $T\_REQ\_LATENCY$  (i.e., time between asserting RADIO\_REQ and WIFI\_GRANT being

asserted consequently) may be defined as  $(T\_GRANT\_MIN + T\_REVOKE\_LEAD + T\_BEACON\_ACT)$ .

[0275] FIGS. 15G-1 and 15G-2 illustrate a signal timing diagram and timing chart for an “alarming” mode of operation for a coexistence scheme, in accordance with some implementations.

[0276] As shown in FIG. 15G-1, RADIO\_PRI is kept activated while in alarming mode, and is de-activated at the termination of the last transmission request (e.g., RADIO\_REQ). The alarming mode may include situations in which critical data is being transmitted and received by the radio 940 (e.g., pings from hazard detection devices being received and transmitted to other devices). In these situations, the coexistence must be configured to support the receipt and transmission of this data, while synchronously transmitting data through the radio 950 (e.g., transmitting data packets of a recorded video stream through Wi-Fi) during intervals of time when the radio 940 is not requesting transmission access (e.g., between transmissions of the radio 940).

[0277] As shown, during an alarming mode, RADIO\_PRI is first asserted, and RADIO\_REQ is asserted at a time  $T\_PRI\_SETUP$  afterwards. Once RADIO\_REQ has been asserted, the radio 950 grants transmission access by asserting WIFI\_GRANT at a time  $T\_REQ\_LATENCY\_A$  afterwards. When the RADIO\_REQ transmission request from the radio 940 finishes, WIFI\_GRANT is revoked at time  $T\_REVOKE\_LATENCY\_A$  afterwards. The interval  $T\_REQ\_INTERVAL\_A$  is an interval of time between transmission requests from the radio 940 (e.g., RADIO\_REQ). During this time, WIFI\_GRANT is revoked, and therefore transmission access is set aside for the radio 950 (e.g., data packets for a video stream over Wi-Fi).

[0278] In some implementations, during an alarming mode, after asserting RADIO\_REQ, the radio 940 begins transmission at a time  $T\_REQ\_LATENCY\_A$  afterwards regardless of whether the WIFI\_GRANT is asserted.

[0279] FIG. 16 shows an illustrative co-existence circuit 1700 for managing operations of three communications circuits, in accordance with some implementations. In the example shown, circuitry 1700 includes 6LOWPAN circuitry 1710 (e.g., a first radio 940, FIG. 9), BLE circuitry 1720 (e.g., a second radio 940), Wi-Fi circuitry 1730 (e.g., a first radio 950), and OR gates 1740 and 1742. Request for Access (RFA) line 1711 may be connected to BLE circuitry 1720 and an input of OR gate 1740. An RFA line may be asserted by a communication circuit when it requires access to an RF medium. An RF medium can include an antenna and/or a communications frequency. RFA line 1721 may be connected to 6LOWPAN circuitry 1710 and an input of OR gate 1740. The output of OR gate 1740 may be connected to Wi-Fi circuitry 1730. Priority Line 1712 may be connected to an input of OR gate 1742, and priority line 1722 may be connected to an input of OR gate 1742. A priority line may be asserted by a communication circuit that is requesting high priority access to the RF medium. The output of OR gate 1742 may be connected to Wi-Fi circuitry 1730. Grant line 1731 may be connected to 6LOWPAN circuitry 1710 and BLE circuitry 1720. Grant signals may be provided on grant line 1731 to indicate which communications circuit is granted access to the RF medium. Grant signals may be provided by a master circuit, which is illustrated as Wi-Fi



circuitry 1730. Each of circuitries 1710, 1720, and 1730 may require access to the same RF medium when communicating data.

[0280] Although the examples provided in FIGS. 16-21 are described with respect to a multi-transceiver device that includes circuitry for 6LOWPAN, BLE, and Wi-Fi transmission protocols specifically, in other implementations, the circuitry 1700 may include any combination of three or more radios 940 and/or radios 950. In such implementations, the methods described in FIGS. 16-21 with respect to priority lines and how respective circuitry operates will apply analogously. In other words, the coexistence schemes and methods described in FIGS. 16-21 are generally applicable to any multi-radio device (e.g., smart devices having three or more radios).

[0281] The RFA lines 1711 and 1721 may be shared among both 6LOWPAN circuitry 1710 and BLE circuitry 1720 so that the circuits are aware of when each makes a request for access. Such information sharing can assist in avoiding collision events. The RFA may be provided to Wi-Fi circuitry 1730, which decides whether to grant access. The priority lines may specify that a particular circuit is given priority over the other circuit and that its request to access the RF medium is of high priority and the other communication circuits should yield where possible. For example, 6LoWPAN circuitry 1710 may have priority over BLE circuitry 1720 during an alarm event. In the event of potential collisions for RF medium access, master or host circuitry can control which circuitry is granted access. The master or host circuitry can be a processor other than one of the communications circuits (e.g., system processor 402) or it can be implemented by an onboard processor of one of the communication circuits (e.g., Wi-Fi circuitry 1730).

[0282] Priority may be conveyed using one of two different approaches. One approach uses direct notification. In this approach, the host (e.g., Wi-Fi 1730) can issue grant command to the communications circuits to inform them which has priority. The grant command may not necessarily be a single Boolean value, but can include an enumeration or bit field indicating which circuit has priority or is allowed to assert its priority line. In another approach, implicit notification may be used. In implicit notification, a circuit may impliedly have priority if its priority input pin is not asserted. If its priority input pin is asserted, then it may not have priority.

[0283] The 6LoWPAN communication circuitry priority cases are shown and described in Table 1.

TABLE 1

No Priority, Yield to BLE Circuitry	6LO_Priority not asserted, yield to BLE when Grant asserted but BLE_RFA also asserted
Priority	6LO_Priority asserted, do not yield BLE_RFA asserted
No Priority, Retain access against BLE Circuitry	6LO_Priority not asserted, do not yield to BLE when Grant asserted but BLE_RFA also asserted

[0284] The BLE communications circuitry priority cases are shown and described in Table 2.

TABLE 2

No Priority	BLE_Priority not asserted, yield to 6LoWPAN when Grant asserted but 6LO_RFA also asserted
Priority	BLE_Priority asserted, do not yield to 6LO_RFA asserted

[0285] The priority cases for Wi-Fi circuitry 1730 are described in connection with FIGS. 17A-17B. FIG. 17A shows an illustrative base case in which both priority lines for 6LOWPAN circuitry 1710 and BLE circuitry 1720 are LOW, indicating that these circuits are not requesting priority. In addition, there are no pulses in 6LO\_RFA nor BLE\_RFA, indicating that 6LoWPAN 1710 and BLE circuitry 1720 are not requesting access. From time t0 to t1, the Grant line is HIGH, implying that Wi-Fi circuitry 1730 is granting access to the RF medium. From time, t1 to time, t2, Grant is LOW and WiFi Tx is HIGH. Thus, Wi-Fi circuitry 1730 denies grant when it wishes to transmit. This is also shown between time, t3 and t4. Moreover, during the base case, 6LoWPAN circuitry 1710 and BLE circuitry 1720 may be permitted to access the RF medium when Grant is HIGH.

[0286] FIG. 17B shows an illustrative case showing grant and denial of 6LoWPAN circuitry 1710 access to the RF medium based status of Grant, in accordance with some implementations. As shown, between times t1 and t2, 6LO\_RFA is HIGH while Grant is HIGH, thereby enabling 6Lo Tx to go HIGH. Starting at time, t3, 6Lo Tx is initially HIGH, but this transmission is denied at time, t4, when Grant is set LOW and WiFi Tx goes HIGH. Then, at time t5, Grant returns to HIGH, thereby enabling 6LoWPAN circuitry to continue transmitting.

[0287] FIGS. 18A-D shows different illustrative 6LoWPAN priority use case, in accordance with some implementations. In particular, FIG. 18A shows an illustrative base case and FIGS. 18B-18D show priority, no priority, and Retain access against BLE priority use cases, respectively, of Table 1. As shown in the base case of FIG. 18A, 6LoWPAN circuitry 1710 requests access twice and is granted access both times. In addition, there are no collisions and 6LO\_Priority and Grant are HIGH throughout.

[0288] FIG. 18B shows an illustrative priority use case for 6LoWPAN in which 6LO\_Priority is HIGH throughout. From times t1-t2, there are not request for access by either 6LO or BLE, thereby enabling Wi-Fi to revoke its Grant and transmit. At time t3, 6LO\_RFA goes HIGH and 6LO Tx transmits from time t3 to t4. At time t5, Wi-Fi Tx goes HIGH. However, at time t6, 6LO\_RFA goes HIGH, and because 6LO has priority, Wi-Fi Tx goes LOW and 6LO is permitted to transmit.

[0289] Referring now to FIG. 18C, 6LO\_Priority and Grant are HIGH throughout. At times t1-t2, BLE\_RFA is HIGH, and because 6LO\_RFA is LOW, there is no conflict, and BLE Tx is permitted to go HIGH. At times t3-t4, 6LO\_RFA is HIGH, and is granted access, resulting in 6LO Tx going HIGH. Starting at time t5, BLE\_RFA is HIGH, and BLE Tx begins to transmit until time, t6, at which point 6LO\_RFA goes HIGH. Now, at time t6, there is a conflict between 6LO\_RFA and BLE\_RFA, but because 6LO\_Priority is HIGH, 6LO Tx goes HIGH, indicating that 6LoWPAN circuitry 1710 decides to transmit despite the assertion by BLE circuitry 1720.

[0290] Referring now to FIG. 18D, both 6LO\_Priority and BLE\_Priority are LOW but circuitry 1700 is configured to

permit grant 6LoWPAN circuitry **1710** access in case of a collision. Starting at time t1, 6LO\_RFA goes HIGH and at time t2, BLE\_RFA goes HIGH, but Grant goes LOW to allow Wi-Fi circuitry to transmit until time t3. At time t3, Grant goes HIGH, at which time, 6LO Tx begins transmitting (as shown). BLE Tx does not transmit because BLE circuitry **1720** does not have priority and knows that 6LO\_RFA has already been asserted. BLE Tx may go HIGH as it detects the falling edge of 6LO Tx at time t4.

**[0291]** The priority use cases for BLE circuitry **1720** are similar to the priority use cases of 6LoWPAN circuitry **1710**. For example, if FIGS. **18A-18C** were used to illustrate the priority use cases of BLE circuitry **1720**, the 6LO priority, RFA, and Tx labels can be transposed with the BLE priority, RFA, and Tx labels.

**[0292]** FIGS. **19A** and **19B** show illustrative timing diagrams where Wi-Fi circuitry **1730** is OFF, in accordance with some implementations. When Wi-Fi circuitry **1730** is OFF, 6LoWPAN circuitry **1710** and BLE circuitry **1720** are operative to arbitrate among themselves to determine who has access to the RF medium. 6LoWPAN circuitry **1710** and BLE circuitry **1720** may arbitrate among themselves based on their priority line assertions and the state of the other circuit's RFA signal. FIG. **19A** illustrates timing diagrams where Wi-Fi is OFF and 6LoWPAN circuitry has priority, in accordance with some implementations. As shown, 6LO\_Priority and Grant are HIGH. At time t1, 6LO\_RFA goes HIGH and then goes LOW at time t2. 6LO Tx is HIGH from times t1 to t2. At time t3, 6LO\_RFA goes HIGH, during which time, 6LO Tx is also HIGH. BLE\_RFA goes HIGH at time t4 and remains HIGH. BLE Tx continues to yield to 6LO Tx until time t5, at which point 6LO\_RFA goes LOW. 6LO Tx may not yield between times t4 and t5, despite the pulse on BLE\_RFA, because 6LoWPAN circuitry **1710** has priority.

**[0293]** FIG. **19B** illustrates timing diagrams where Wi-Fi is OFF and BLE circuitry has priority, in accordance with some implementations. As shown, Grant and BLE\_Priority are HIGH. At times t1 to t2, 6LO Tx is permitted access to transmit since there is no collision. At time t3, 6LO\_RFA goes HIGH, and 6LO Tx begins transmitting. At time t4, however, BLE\_RFA goes HIGH. Since BLE circuitry has priority, BLE Tx takes priority over 6LO Tx. As a result, BLE Tx goes HIGH and 6LO Tx goes LOW.

**[0294]** Referring now to FIG. **20**, an illustrative timing diagram showing how the BLE circuitry attempts to communicate with a personal device during the idle portion of a wake packet being transmitted by 6LoWPAN circuitry during a NCCA period, in accordance with some implementations. During the NCCA period, Wi-Fi circuitry **1730** is not yet turned ON, therefore 6LoWPAN circuitry **1710** and BLE circuitry **1720** may arbitrate amongst themselves to determine who has access to the RF medium. For purposes of this timing diagram, assume that the 6LoWPAN has priority (e.g., because hazard detection system has raised its alarm). FIG. **20** shows that the NCCA wake packet transmission cycle has a period including an active portion (as evidenced by the HIGH pulse) and an idle portion (as evidenced by the LOW signal). The 6LoWPAN\_RFA may track the active portion of each wake packet. Since 6LoWPAN circuitry **1710** has priority, it controls access to the RF medium regardless of any RFA by BLE circuitry **620**. This is shown in the FIG., as evidenced by 6LoWPAN Tx going HIGH in concert with the 6LoWPAN pulses. BLE\_RFA is shown to

remain HIGH throughout the timing diagram, thus indicating BLE circuitry **1720**'s desire to attempt communications with a personal device (not shown). BLE circuitry **1720** is permitted to communicate during the idle portion of each wake packet transmission. This is shown where BLE Tx goes HIGH when 6LoWPAN Tx goes LOW, and vice versa.

**[0295]** During the BLE Tx HIGH signal period, BLE circuitry **1720** attempts to communicate with one or more personal devices. BLE circuitry **1720** may do this by 1) advertising its presence to the personal device (e.g., on channel 37 of a BLE protocol), 2) authenticating the personal device (e.g., on channel 38 of the BLE protocol), and 3) commencing data transfer with the personal device (e.g., on channel 39 of the BLE protocol). BLE circuitry **1720** may perform all three steps during a single BLE Tx session or over a series of BLE Tx sessions. The data transfer can specify instructions for altering the state of the system. For example, if the system is alarming, the instruction can contain a hush instruction that commands the system to change from an alarming state to a hush state.

**[0296]** FIG. **21** shows illustrative timing diagrams of exemplary BLE advertise, connect, and data transfer activity during BLE transmissions, in accordance with some implementations. The BLE operations of advertise, connect, and data transfer may occur during BLE\_Tx activity, which occur when BLE\_Tx is HIGH. As shown in FIG. **21**, the BLE operations are performed in one of the four BLE\_Tx activity windows. BLE Advertise may occur during BLE\_Tx activity window **1**, and BLE connect may occur during BLE\_Tx activity window **2**. After a connection is made, BLE data may be transmitted between a personal device and the system during windows **3** and **4**.

**[0297]** FIG. **22** is a flow diagram illustrating a method of coexistence using bypass circuitry, in accordance with some implementations. In some implementations, the method **2200** is performed at an electronic device (e.g., devices of a smart home environment **100**, FIGS. **1** and **12**; smart devices **204** and/or hub device **180** of smart home network **202**, FIG. **2**) having a plurality of transceivers and antennas (e.g., smart device **204**, FIG. **14**, having one or more radios **940** and/or radios **950**, and antennas **1402**). More specifically, in some implementations, the method **2200** is performed by one or more components of the electronic device (e.g., communications module **942** of smart device **204**, or a front end module **1400** of the communications module). For ease of reference, the methods herein will be described as being performed by an electronic device (e.g., smart device **204**). FIG. **22** corresponds to instructions stored in a computer memory or other computer-readable storage medium (e.g., memory **606** of the hub device **180**), or instructions stored in the memory of one or more components of the electronic device (e.g., memory of the communications module **942**, not illustrated).

**[0298]** The electronic device (e.g., smart device **204**, which is a camera) includes a plurality of transceivers (e.g., radio(s) **940** and radio(s) **950**, FIG. **14**), one or more processors, and memory storing instructions for execution by the one or more processors. The electronic device detects (**2204**) whether a second transceiver (e.g., radio **950**) of the plurality of transceivers is not transmitting signals via a second antenna (e.g., antenna **1402-2**) coupled to the second transceiver. In some implementations, a bypass signal is produced (**2202**) when the second transceiver is active, where detecting (**2204**) whether the second transceiver is

transmitting signals includes (2206) detect the bypass signal. For example, a bypass signal is produced and detected on connection 1410 (FIG. 14) when radio 950 is transmitting. [0299] In accordance with detecting that the second transceiver is not transmitting signals via the second antenna, a first transceiver (e.g., radio 940) of the plurality of transceivers is coupled (2208) to a first antenna via an amplifier such that a signal received by the first antenna is amplified by the amplifier prior to being passed to the first transceiver. In some implementations, the amplifier is a low-noise amplifier (e.g., low noise amplifier 1406-2, FIG. 14).

[0300] In accordance with detecting that the second transceiver is transmitting signals via the second antenna, the first transceiver is coupled (2210) to the first antenna via a bypass line (e.g., bypass line 1408) such that a signal received by the first antenna is not amplified by the amplifier prior to being passed to the first transceiver.

[0301] In some implementations, the first and second antennas receive and transmit signals at the same frequency (e.g., 2.4 GHz).

[0302] FIGS. 23A-23F are flow diagrams illustrating methods of using control signals in a coexistence scheme, in accordance with some implementations. In some implementations, the methods 2300 and 2330 are performed at an electronic device having a plurality of transceivers and antennas (e.g., smart device 204 of FIGS. 9 and 15A-15B, having one or more radios 940 and/or radios 950). More specifically, in some implementations, the methods 2300 and 2330 are performed by one or more components of the camera device (e.g., communications module 942 of smart device 204). For ease of reference, the methods herein will be described as being performed at a camera device (e.g., smart device 204 of FIG. 15A, a camera). FIGS. 23A-23F correspond to instructions stored in a computer memory or other computer-readable storage medium (e.g., memory 606 of the hub device 180), or instructions stored in the memory of one or more components of the electronic device (e.g., memory of the communications module 942, not illustrated).

[0303] The camera device includes a plurality of distinct transceivers configured for communication over respective communication protocols (e.g., radio 940 and radios 950, which includes radios 950-1 and 950-2, FIGS. 15A-15B), one or more processors, and memory storing instructions for execution by the one or more processors.

[0304] In performing the method 2300, the camera device communicates (2302) using a first transceiver of the plurality of distinct transceivers, the first transceiver configured to transmit and receive, over a first one of the communication protocols, signals for configuring the camera device (e.g., radio 950-1 of radios 950, FIGS. 15A-15B). In some implementations, the first communication protocol is (2304) based on the Bluetooth Low Energy standard. In some implementations, communicating (2302) using the first transceiver includes transmitting (2306) data comprising a video format configured for low-bandwidth transmissions (e.g., a low resolution encoded video stream).

[0305] The camera device communicates (2308) with one or more smart home devices using a second transceiver of the plurality of transceivers. The second transceiver (e.g., radio 940, FIG. 15A) is configured to transmit and receive, over a second one of the communication protocols, signals comprising one or more of alerts, control signals and status information to and from the one or more smart home devices (e.g., emergency alerts from hazard detectors 104, FIG. 1).

In some implementations, the second communication protocol is based (2310) on the IEEE 802.15.4 standard. In some implementations, communicating (2308) using the second transceiver includes (2312) transmitting data comprising the video format configured for low-bandwidth transmissions (e.g., a low resolution encoded video stream). In some implementations, communicating (2308) using the second transceiver includes (2314) receiving intermittent signals from the one or more smart home devices and/or retransmitting received signals from the one or more smart home devices, concurrently with the transmission of data using a third transceiver (e.g., receiving emergency pings from connected smart hazard detectors 104 using radio 940 (FIG. 15A) while transmitting video data over Wi-Fi radio 950-2 (FIGS. 15A-15B)). In some implementations, the transmission of data using the third transceiver is temporarily suspended (2316) while receiving signals from the one or more smart home devices and/or retransmitting received signals from the one or more smart home devices. For example, radio 940 and radios 950 coordinate transmission access such that the radio 940 and radios 950 are not both simultaneously transmitting signals at a given time (e.g., communications module 942 moderates transmission access by the radio 940 and radios 950, and selectively grants/denies transmission access to the radio 940 and radios 950).

[0306] Referring now to FIG. 23B, the camera device communicates (2318) using the third transceiver of the plurality of transceivers. The third transceiver (e.g., radio 950-2 of radios 950, FIGS. 15A-15B) is configured to transmit and receive, over a third one of the communication protocols, data corresponding to video captured by the camera device. In some implementations, the third communication protocol is based (2320) on the IEEE 802.11 standard. In some implementations, the data comprises (2322) a video format configured for high-bandwidth transmissions (e.g., high resolution video streaming of video surveillance footage using Wi-Fi). In some implementations, communicating (2318) using the third transceiver includes (2324) receiving and transmitting data at a data rate that is higher than a data rate at which the camera device communicates using the first transceiver and/or a data rate at which the camera device communicates using the second transceiver (e.g., streaming high-resolution video using Wi-Fi radio 950-2, while streaming low-resolution video using 802.15.4 radio 940, FIGS. 15A-15B).

[0307] In some implementations, the camera device receives (2326) signals from the one or more smart home devices over the second communication protocol, and retransmits (2328) the signals to one or more other smart home devices (e.g., receiving and retransmitting emergency pings from connected smart hazard detectors 104 using radio 940, FIG. 15A).

[0308] Referring now to FIG. 23C, the camera device may perform the method 2330 additionally to and/or in conjunction with the method 2300. In performing the method 2330, in some implementations, the camera device grant or deny transmission access to the first transceiver (e.g., radio 950-1 of radios 950, FIGS. 15A-15B, such as Bluetooth LE), the second transceiver (e.g., radio 940, FIG. 15A, such as 802.15.4), and/or the third transceiver (e.g., radio 950-2 of radios 950, FIGS. 15A-15B, such as Wi-Fi) of the plurality of distinct transceivers of the camera device, where the transceivers are configured for communication over respective communication protocols.

[0309] In some implementations, granting or denying transmission access (2332) includes (2334) detecting activation of a priority control signal (e.g., assertion of RADIO\_PRI signal on control line 1500-1, FIG. 15A). In some implementations, the activated priority control signal corresponds (2336) to an alarming mode of the second transceiver (e.g., incoming emergency alerts from a hazard detector 104). In response to detecting activation of the priority control signal, transmission access is granted (e.g., by the “master” transceiver, such as radio(s) 950, FIG. 15A) to the second transceiver (e.g., e.g., 802.15.4 radio 940) and transmission access is denied to the third transceiver (e.g., Wi-Fi radio 950-2).

[0310] In some implementations, an activated priority control signal is detected (2304) (e.g., an already asserted RADIO\_PRI signal on control line 1500-1 is detected). While detecting the activated priority control signal (2342), activation of a radio request control signal by the second transceiver is detected (2344) (e.g., assertion of RADIO\_REQ signal on control line 1500-2). In response to detecting activation of the radio request control signal by the second transceiver, transmission access is granted (2346) to the second transceiver and transmission access is denied to the third transceiver. In some implementations, granting transmission access to the second transceiver and denying transmission access to the third transceiver includes (2348) activating the grant control signal (e.g., asserting WIFI\_GRANT signal on control line 1500-3, FIG. 15A). A corresponding example of steps 2340 through 2348 is illustrated in FIGS. 15G-1.

[0311] In some implementations, while detecting the activated priority control signal, a transmission request is detected (2350) by the third transceiver. In some implementations, the transmission request by the third transceiver is detected (2352) while transmission access is granted to the second transceiver. In response to detecting the transmission request by the third transceiver, and while detecting the activated radio request control signal by the second transceiver, transmission access continues (2354) to be granted to the second transceiver while transmission access continues to be denied to the third transceiver. Thus, in some implementations, while the priority control signal is activated, the third transceiver is not permitted to transmit data.

[0312] In some implementations, while continuing to detect the activated radio request control signal and the activated priority control signal, transmission access continues (2356) to be granted to the second transceiver and transmission access continues to be denied to the third transceiver.

[0313] Referring now to FIG. 23D, in some implementations, while detecting the activated priority control signal, deactivation of the radio request control by the second transceiver is detected (2360) (e.g., de-assertion of RADIO\_REQ signal on control line 1500-2). In response to detecting deactivation of the radio request control signal by the second transceiver, transmission access to the second transceiver is revoked (2362) and transmission access to the third transceiver is granted. In some implementations, revoking transmission access to the second transceiver and granting transmission access to the third transceiver includes (2364) deactivating the grant control signal (e.g., de-asserting WIFI\_GRANT signal on control line 1500-3). A corresponding example of steps 2360 through 2364 is illustrated in FIGS. 15G-1.

[0314] In some implementations, a deactivated priority control signal is detected (2366) (e.g., an already de-asserted RADIO\_PRI signal on control line 1500-1 is detected). While detecting the deactivated priority control signal (2368), activation of the radio request control signal by the second transceiver is detected (2370). In response to detecting activation of the radio request control signal by the second transceiver, transmission access is granted (2372) to the second transceiver and transmission access is denied to the third transceiver. In some implementations, while transmission access is granted to the second transceiver, a transmission request by the third transceiver is detected (2374). In some implementations, the transmission request by the third transceiver is detected (2376) while detecting the activated radio request control signal. In some implementations, the transmission request by the third transceiver is (2378) a high priority transmission request (e.g., a transmission request within an access category above BE (Best Effort), VI (Video), and/or VO (Voice)). In response to detecting the transmission request by the third transceiver, transmission access is revoked (2380) to the second transceiver and transmission access is granted to the third transceiver. In some implementations, while transmission access is granted to the third transceiver, a high priority transmission by the third transceiver is detected (2382) to be in progress. Upon completion of the high priority transmission, transmission access is granted (2384) to the second transceiver and transmission access is revoked to the third transceiver. A corresponding example of steps 2366 through 2384 is illustrated in FIGS. 15E-1.

[0315] In some implementations, the camera device communicates (2302) using the first transceiver, communicates (2308) with one or more smart home devices using the second transceiver, and communicates (2318) using the third transceiver (where the steps 2302, 2308, and 2318 may be performed in accordance with any of the implementations described with respect to FIGS. 23A-23B).

[0316] FIGS. 24A-24D illustrate various types of antennas for use with the various devices disclosed herein. For example, the antenna types illustrated in FIGS. 24A-24D are optionally used with the camera devices illustrated in FIGS. 25-29, discussed below. In accordance with some implementations, each of the antenna types is optionally used with various communication protocols, such as ZigBee, Z-Wave, Insteon, EuOcean, Thread, OSIAN, Bluetooth Low Energy and the like. In accordance with some implementations, each of the antenna types is optionally used with various wired or wireless protocols, such as Ethernet, Universal Serial Bus (USB), FIREWIRE, Long Term Evolution (LTE), Global System for Mobile Communications (GSM), Enhanced Data GSM Environment (EDGE), code division multiple access (CDMA), time division multiple access (TDMA), Bluetooth, Wi-Fi, voice over Internet Protocol (VoIP), WiMAX, or any other suitable communication protocol.

[0317] FIG. 24A illustrates an example of an external antenna, external antenna 2402, for use with the various devices disclosed herein. An external antenna is sometimes also called a whip antenna. In some implementations, the external antenna 2402 is coupled to a device, such as a camera device, via a coaxial connector. In some implementations, the external antenna 2402 is coupled to the device via any suitable cable connector, such as BNC, F-type, FME, MC-Card, MCX, MMCX, QMA, SMB, SSMB, and the like. In some implementations, the external antenna is mounted to

the device casing. In some implementations, the external antenna is a dipole antenna (e.g., with a size of  $\frac{1}{2}$  wavelength). In some implementations, the external antenna is a monopole antenna (e.g., with a size of  $\frac{1}{4}$  wavelength). In some instances, the optimal orientation of a dipole or monopole type external antenna is perpendicular to the local ground plane of the device. In some implementations, the external antenna includes a hinge or swivel to enable a user to adjust the angle and positioning of the antenna relative to the device.

[0318] In some implementations, the external antenna 2402 comprises a vertical wire and/or one or more traces on a circuit board, typically encased in a plastic housing. In some implementations, the external antenna is external to the main housing of the device and is perpendicular to the largest dimension(s) of the device. External antennas may achieve high efficiency and have, in general, better immunity to the self-generated noise of the device than internal/embedded antenna. While external antennas may provide superior performance, there are disadvantages in some instances due to: susceptibility to damage, additional manufacturing cost, and potential performance degradation due to the user's interaction with the exposed antenna.

[0319] FIGS. 24B-24D illustrate various types of internal antennas for use with the various devices disclosed herein. Internal antennas are sometimes called embedded antennas. As used herein, an internal antenna includes any antenna that lies completely within the device casing. Internal antennas are generally not implemented within metal casings as the metal casing will degrade efficiency. The internal antennas are coupled to a communications module. The communications module is sometimes called a radio module or a radio. In some implementations, the communications module comprises a communications chip. In some implementations, an internal antenna is coupled to a communications module via one or more controlled impedance structures, such as coaxial cable, controlled impedance circuit board traces (e.g., microstrip or stripline), spring-loaded pogo pins or spring fingers, flex circuits with controlled impedance lines, and the like. In some implementations, the internal antenna is coupled to the communications module via one or more filters, amplifiers, and/or switches. Cables and traces will introduce losses and should be carefully considered. For example, cables and traces create opportunities for noise to enter the receiver system.

[0320] Internal antennas are susceptible to interference with other device components (including other internal antennas). In some instances, the primary noise source is the digital circuitry, such as the processor(s) and memory. For example, in some instances, processor clocks, high-speed memory, displays, and graphics processors are the highest sources of noise and produce the widest range of frequencies. In some implementations, the digital electronics are shielded with board-mounted shield cans. In some implementations, the antenna(s) are positioned as far from the largest noise sources as possible. In some implementations, the antenna interconnect(s) are routed away from the largest noise sources. In some implementations, non-shielded antenna interconnects (e.g., spring fingers or pogo pins) are positioned to limit exposure to the largest noise sources.

[0321] FIG. 24B illustrates an example of a sheet metal antenna for use with the various devices disclosed herein. A sheet metal antenna is also sometimes called a stamped metal antenna. In FIG. 24B, sheet metal antenna 2404 is

mounted on circuit board 2406 and coupled to communications module 2408. In some implementations, sheet metal antenna 2404 is mounted perpendicular to the plane of circuit board 2406. In some implementations, sheet metal antenna 2404 is mounted parallel to the plane of circuit board 2406. In some implementations, sheet metal antenna 2404 is an inverted-F style antenna. In some implementations, sheet metal antenna 2404 comprises a patch antenna. In some implementations, the patch antenna is a printed patch antenna. In some implementations, the patch antenna is printed on a surface of a multi-layer circuit board. In some implementations, the patch antenna comprises a directional antenna with a primary lobe of radiation oriented away from the ground plane of the device.

[0322] The size and shape of the local ground plane and the relatively close spacing of the ground plane to the antenna element have an impact on the antenna design. Sheet metal antennas are optimally placed on the edge of a ground plane, such as the edge of a circuit board, or on top of a planar ground plane surface. Thus, a sheet metal antenna is optimally not surrounded by ground planes and/or other conducting surfaces.

[0323] FIG. 24C illustrates an example of a board antenna for use with the various devices disclosed herein. A board antenna is sometimes also called a printed circuit board (PCB) antenna or a PCB trace antenna. In FIG. 24C, board antenna 2412 is mounted on circuit board 2410 and is coupled to communications module 2414. Board antennas are generally affected by the circuit board's substrate properties, such as the dielectric constant and dissipation factor. In some implementations, the board antenna 2412 comprises a single-ended antenna. In some implementations, the board antenna 2412 comprises a differential antenna. In some implementations, the board antenna 2412 comprises a Yagi antenna. In some implementations, the board antenna 2412 comprises an F antenna. In some implementations, the board antenna 2412 comprises an inverted-F antenna. In some implementations, the board antenna 2412 is laminated on the circuit board 2410 surface. In some implementations, the board antenna 2412 occupies one or more layers on the circuit board 2410.

[0324] FIG. 24D illustrates an example of a chip antenna for use with the various devices disclosed herein. In FIG. 24D, antenna chip 2422 is mounted on board 2420. In some implementations, chip antennas are placed on a circuit board like a standard circuit component, although these antennas generally suffer in efficiency. Chip antennas are generally affected by the circuit board's substrate properties, such as the dielectric constant and dissipation factor. The circuit board's substrate material reduces the resonant length of the antenna, which results in a reduction of the usable bandwidth. The circuit board substrate also introduces a loss mechanism and reduces the antenna's efficiency. In some instances where the available board space for the antenna is limited, a chip antenna is an optimal antenna type. In some implementations, the chip antenna 2422 comprises a ceramic chip antenna. In some implementations, the chip antenna 2422 comprises an F antenna. In some implementations, the chip antenna 2422 comprises an inverted-F antenna. In some implementations, the chip antenna 2422 comprises a monopole antenna.

[0325] As previously discussed, FIG. 11D illustrates an example of adhesive antennas for use with the various devices disclosed herein. Adhesive antennas 1104-1 and

**1104-2** are mounted to cover **1102** (also sometimes called a casing or a housing). In some implementations, the adhesive antenna **1104** comprises a tape antenna. In some implementations, the adhesive antenna **1104** comprises a sticker antenna. In some implementations, the adhesive antenna **1104** comprises a conductive paint antenna. In some implementations, the adhesive antenna **1104** comprises a wire antenna.

[0326] FIGS. 25A-25F illustrate various assembly views of a camera device, in accordance with some implementations. FIG. 25A shows an exterior view of camera device **2500** including casing **2501**, lens **2516**, status LED **2514**, microphone **2508**, status LED **2512**, light sensor **2510**, LED **2502**, motion sensor **2504**, and speaker **2506**. In some implementations, casing **2501** comprises a plastic casing. In some implementations, LED **2502** is an infrared (IR) LED. In some implementations, status LED **2512** indicates whether camera device **2500** is coupled to another device (such as a router) via a wireless connection. In some implementations, status LED **2512** indicates the WPS status of camera device **2500**. In some implementations, status LED **2514** indicates the camera status of camera device **2500**. In some implementations, motion sensor **2504** is a passive infrared sensor for motion detection. In some implementations, light sensor **2510** comprises an IR-cut removable sensor. In some implementations, camera device **2500** switches between color mode and infrared mode based on output from light sensor **2510**. In some implementations, LED **2502** is utilized to provide illumination when camera device **2500** is in infrared mode.

[0327] FIG. 25B shows another exterior view of camera device **2500** including casing **2501**, lens **2516**, status LED **2514**, microphone **2508**, status LED **2512**, light sensor **2510**, LED **2502**, motion sensor **2504**, speaker **2506**, and height adjuster **2520**. In some implementations, height adjuster **2520** comprises an adjustment ring for adjusting the positioning of camera device **2500**. In some implementations, camera device **2500** includes a storage card slot, such as a Micro SD card slot (not shown).

[0328] FIG. 25C shows another exterior view of camera device **2500** including casing **2501**, power connector **2528**, I/O connector **2526**, connectivity port **2530**, height adjuster **2520**, wireless affordance **2522**, and reset **2524**. In some implementations, I/O connector **2526** comprises a DI/DO connector. In some implementations, connectivity port **2530** comprises an RJ45 connection port. In some implementations, reset **2524** is utilized to reset the state of camera device **2500**. In some implementations, wire affordance **2522** comprises a WPS button for establishing a wireless connection.

[0329] FIG. 25C also shows regions **2527** and **2529** on casing **2501**. In some implementations, camera device **2500** includes one or more external antenna, such as antenna **2402** in FIG. 24A. In some implementations, an external antenna is located in region **2527**. In some implementations, an external antenna is located in region **2529**. In some implementations, an external antenna is located at another position on camera device **2500**. In some implementations, the external antenna is utilized with one or more of a variety of custom or standard wireless protocols (e.g., IEEE 802.15.4, Wi-Fi, ZigBee, 6LoWPAN, Thread, Z-Wave, Bluetooth Smart, ISA100.11a, WirelessHART, MiWi, etc.).

[0330] FIG. 25D shows an interior view of camera device **2500** including casing **2501**, circuit board **2541**, microphone **2508**, speaker **2506**, and lens **2516**. Circuit board **2541**

includes memory **2542**, antenna **2540**, LED **2502**, and motion sensor **2504**. In some implementations, memory **2542** comprises flash memory. In some implementations, antenna **2540** comprises a sheet metal antenna (e.g., antenna **2404** in FIG. 24B). In some implementations, antenna **2540** is utilized with Wi-Fi and/or Bluetooth wireless communications. In some implementations, antenna **2540** is utilized with 15.4 wireless communications. In some implementations, an external antenna (e.g., an external antenna located in region **2527** or **2529** in FIG. 25C) is utilized for 15.4 wireless communications and antenna **2540** is utilized with Wi-Fi communications. In some implementations, an external antenna is utilized for Bluetooth communications and antenna **2540** used for Wi-Fi communications.

[0331] FIG. 25D also shows regions **2550**, **2552**, **2556**, **2558**, and **2560** on casing **2501** and region **2560** on circuit board **2541**. In some implementations, camera device **2500** includes one or more internal antennas in addition to antenna **2540**. In some implementations, the one or more internal antennas include a sheet metal antenna (e.g., antenna **2404** in FIG. 24B). In some implementations, the one or more internal antennas include a board antenna (e.g., antenna **2414** in FIG. 24C). In some implementations, the one or more internal antennas include a chip antenna (e.g., antenna **2422** in FIG. 24D). In some implementations, the one or more internal antennas include an adhesive antenna (e.g., antenna **1104-1** in FIG. 11D).

[0332] In some implementations, an internal antenna, such as an adhesive antenna, is located in region **2550**. In some implementations, an internal antenna, such as an adhesive antenna, is located in region **2552**. In some implementations, an internal antenna, such as an adhesive antenna, is located in region **2556**. In some implementations, an internal antenna, such as an adhesive antenna, is located in region **2558**. In some implementations, an internal antenna, such as a chip antenna, is located in region **2554**. In some implementations, an internal antenna is located at another position within camera device **2500**. In some implementations, the internal antenna is utilized with one or more of a variety of custom or standard wireless protocols (e.g., IEEE 802.15.4, Wi-Fi, ZigBee, 6LoWPAN, Thread, Z-Wave, Bluetooth Smart, ISA100.11a, WirelessHART, MiWi, etc.). In some implementations, the internal antenna is utilized for 15.4 wireless communications and antenna **2540** is utilized for Wi-Fi communications.

[0333] FIG. 25E shows a first side of circuit board **2541**. The first side of circuit board **2541** includes memory **2542**, antenna **2540**, LED **2502**, and motion sensor **2504**. The first side of circuit board **2541** also includes connections to speaker **2506** and microphone **2508**. FIG. 25E also shows region **2554** and region **2560**. In some implementations, an internal antenna, such as a chip antenna or a board antenna, is located in region **2560**.

[0334] FIG. 25F shows a second side of circuit board **2541**. The second side of circuit board **2541** includes processor **2545**, power connector **2528**, I/O connector **2526**, card slot **2543**, ethernet port **2530**, wireless affordance **2522**, reset **2524**, energy storage device **2546**, and wireless communications module **2548**. In some implementations, card slot **2543** comprises a MicroSD card slot. Wireless communications module **2548** is coupled to antenna **2540**. In some implementations, wireless communications module **2548** comprises a wireless communications chip. In some implementations, wireless communications module **2548** com-

prises communications module **942**. In some implementations, wireless communications module **2548** is located on a separate board bonded to circuit board **2541**. In some implementations, wireless communications module **2548** is utilized with one or more of a variety of custom or standard wireless protocols (e.g., IEEE 802.15.4, Wi-Fi, ZigBee, 6LoWPAN, Thread, Z-Wave, Bluetooth Smart, ISA100.11a, WirelessHART, MiWi, etc.).

[0335] FIG. 25F also shows region **2562** on circuit board **2541**. In some implementations, an internal antenna, such as a chip antenna or a board antenna, is located in region **2562**. In some implementations, camera device **2500** includes multiple antennas and each antenna is coupled to a distinct communications module. For example, an external antenna is coupled to a first communications module for use with Wi-Fi communications and antenna **2540** is coupled to a second communications module for use with Bluetooth communications. In some implementations, the camera device **2500** includes a controller module to manage operations of the first and second communications modules. In some implementations, one or more of the arbitration methods and/or schemes described herein (e.g., as discussed above with respect to FIG. 15A) are utilized to manage operations between communications modules, radios, and/or antennas. In some implementations, one or more of the co-existence methods and/or circuits described herein (e.g., as discussed above with respect to FIG. 16) are utilized to manage operations between communications modules, radios, and/or antennas. In some implementations, camera device **2500** includes multiple antennas coupled to a single communications module. In some implementations, camera device **2500** includes an antenna coupled to multiple communications modules.

[0336] In some implementations, a communications module is located in region **2560** (FIG. 25E). In some implementations, a communications module is located in region **2554** (FIG. 25E). In some implementations, a communications module is located in region **2562** (FIG. 25F). For example, camera device **2500** includes a first antenna (e.g., sheet metal antenna **2540** in FIG. 25E) coupled to a first communications module (e.g., wireless communications module **2548** in FIG. 25F) and a second antenna, such as adhesive antenna (e.g., located in region **2552** in FIG. 25D), coupled to a second communications module (e.g., located in region **2554** in FIG. 25D). As another example, camera device **2500** includes a first antenna (e.g., sheet metal antenna **2540** in FIG. 25E) coupled to a first communications module (e.g., wireless communications module **2548** in FIG. 25F) and a second antenna, such as a chip antenna (e.g., located in region **2554** in FIG. 25D), coupled to a second communications module (e.g., located in region **2560** in FIG. 25D).

[0337] In some implementations, camera device **2500** includes a communications controller for managing communications via multiple antennas and/or multiple radios. In some implementations, the communications controller comprises a communications module (e.g., communications module **942** in FIG. 14). In some implementations, the communications controller is located in region **2560** (FIG. 25E). In some implementations, the communications controller is located in region **2554** (FIG. 25E). In some implementations, the communications controller is located in region **2562** (FIG. 25F). For example, camera device **2500** includes: (1) a first antenna (e.g., sheet metal antenna **2540**

in FIG. 25E) coupled to a first communications module (e.g., wireless communications module **2548** in FIG. 25F); (2) a second antenna, such as an external antenna (e.g., located in region **2527** in FIG. 25C), coupled to a second communications module (e.g., located in region **2560** in FIG. 25D); and (3) a communications controller (e.g., located in region **2562** in FIG. 25F).

[0338] FIGS. 26A-26J illustrate various assembly views of a camera device, in accordance with some implementations. FIG. 26A shows an exterior view of camera device **2600** including casing **2601**, lens **2602**, LEDs **2604**, antenna **2606**, power LED **2608**, reset affordance **2610**, light sensor **2612**, microphone **2614**, and stand **2616**. In some implementations, casing **2601** comprises a plastic casing. In some implementations, stand **2616** comprises a metal stand. In some implementations, LEDs **2602** are an infrared (IR) LEDs. In some implementations, camera device **2600** includes a motion sensor such as a passive infrared sensor for motion detection. In some implementations, light sensor **2612** comprises an IR-cut removable sensor. In some implementations, camera device **2600** switches between color mode and infrared mode based on output from light sensor **2612**. In some implementations, LEDs **2602** are utilized to provide illumination when camera device **2600** is in infrared mode. In some implementations, reset affordance **2610** is utilized to reset the camera device **2600** to a known state. In some implementations, microphone **2614** is utilized to detect noise above a predefined threshold. In some implementations, microphone **2614** is utilized to receive voice commands. In some implementations, antenna **2606** comprises external antenna **2402**. In some implementations, antenna **2606** is utilized with one or more of a variety of custom or standard wireless protocols (e.g., IEEE 802.15.4, Wi-Fi, ZigBee, 6LoWPAN, Thread, Z-Wave, Bluetooth Smart, ISA100.11a, WirelessHART, MiWi, etc.). In some implementations, antenna **2606** is utilized with Wi-Fi and/or Bluetooth wireless communications. In some implementations, antenna **2606** is utilized with 15.4 wireless communications. In some implementations, an internal antenna is utilized for 15.4 wireless communications and antenna **2606** is utilized with Wi-Fi communications. In some implementations, an internal antenna is utilized for Bluetooth communications and antenna **2606** used for Wi-Fi communications.

[0339] FIG. 26A also shows region **2603** on casing **2601**. In some implementations, camera device **2600** includes one or more additional external antennas (e.g., external antenna **2402**, FIG. 24A) in addition to external antenna **2606**. In some implementations, an external antenna is located in region **2603**. For example, an external antenna similar in design to antenna **2606** is located in region **2603**. In some implementations, antenna **2606** is utilized for communications at a first wavelength and the one or more additional external antennas are utilized for communications at one or more wavelengths distinct from the first wavelength. For example, the additional external antenna is utilized for 15.4 wireless communications and antenna **2606** is utilized for Wi-Fi communications. In some implementations, an external antenna is located at another position on camera device **2600**.

[0340] FIGS. 26B and 26C show additional exterior views of camera device **2600**. FIG. 26B shows an exterior view of the front of camera device **2600** including casing **2601**, lens **2602**, LEDs **2604**, antenna **2606**, power LED **2608**, light

sensor 2612, microphone 2614, and stand 2616. FIG. 26C shows an exterior view of a side of camera device 2600 including casing 2601, LEDs 2604, antenna 2606, reset affordance 2610, and stand 2616. In some implementations, camera device 2600 further includes a power port and/or a wired communications port, such as an Ethernet port.

[0341] FIG. 26D shows an interior view of camera device 2600 including casing 2601, circuit board 2622, circuit board 2620, and lens 2602. Circuit board 2622 includes microphone 2614 and processor 2650. In some implementations, processor 2650 comprises a system-on-chip (SoC). Circuit board 2620 includes LEDs 2604.

[0342] FIG. 26D also shows regions 2625, 2627, 2629, 2631, 2637, and 2639 on casing 2601, region 2623 on circuit board 2622, and regions 2633 and 2635 on circuit board 2620. In some implementations, camera device 2600 includes one or more internal antennas. In some implementations, the one or more internal antennas include a sheet metal antenna (e.g., antenna 2404 in FIG. 24B). In some implementations, the one or more internal antennas include a board antenna (e.g., antenna 2414 in FIG. 24C). In some implementations, the one or more internal antennas include a chip antenna (e.g., antenna 2422 in FIG. 24D). In some implementations, the one or more internal antennas include an adhesive antenna (e.g., antenna 1104-1 in FIG. 11D).

[0343] In some implementations, an internal antenna, such as an adhesive antenna, is located in region 2625. In some implementations, an internal antenna, such as an adhesive antenna, is located in at least one of regions 2627, 2629, 2631, 2637, and 2639. In some implementations, an internal antenna, such as a chip antenna, is located in region 2625. In some implementations, an internal antenna, such as a board antenna, is located in region 2635. In some implementations, an internal antenna, such as a sheet metal antenna, is located in region 2633. In some implementations, an internal antenna is located at another position within camera device 2600. In some implementations, the internal antenna is utilized with one or more of a variety of custom or standard wireless protocols (e.g., IEEE 802.15.4, Wi-Fi, ZigBee, 6LoWPAN, Thread, Z-Wave, Bluetooth Smart, ISA100.11a, WirelessHART, MiWi, etc.). In some implementations, the internal antenna is utilized for 15.4 wireless communications and antenna 2606 (FIG. 26A) is utilized for Wi-Fi communications.

[0344] FIG. 26E shows another interior view of camera device 2600 including casing 2601, circuit board 2632, antenna 2606, and lens 2602. In some implementations, lens 2602 is mounted to board 2632. In some implementations, antenna 2606 is communicatively coupled to circuit board 2622.

[0345] FIG. 26E also shows regions 2625, 2627, 2629, 2631, 2641, and 2643 on casing 2601 and region 2647 on board 2632. In some implementations, an internal antenna, such as an adhesive antenna, is located in at least one of regions 2625, 2627, 2629, 2631, 2641, and 2643. In some implementations, an internal antenna, such as a chip antenna, is located in region 2647. In some implementations, an internal antenna is located at another position within camera device 2600. In some implementations, the internal antenna is utilized with one or more of a variety of custom or standard wireless protocols (e.g., IEEE 802.15.4, Wi-Fi, ZigBee, 6LoWPAN, Thread, Z-Wave, Bluetooth Smart, ISA100.11a, WirelessHART, MiWi, etc.). In some implementations, the internal antenna is utilized for Bluetooth

wireless communications and antenna 2606 (FIG. 26A) is utilized for Wi-Fi communications.

[0346] FIG. 26F shows a first side of circuit board 2622. The first side of circuit board 2622 includes processor 2650 and microphone 2614. FIG. 26F also shows region 2623. In some implementations, an internal antenna, such as a chip antenna or a board antenna, is located in region 2623. In some implementations, an internal antenna is located at another location on circuit board 2622.

[0347] FIG. 26G shows a second side of circuit board 2622. The second side of circuit board 2622 includes reset affordance 2610, communications port 2626, card slot 2628, and power connector 2630. In some implementations, communications port 2626 comprises an Ethernet port. In some implementations, card slot 2628 comprises a MicroSD card slot. FIG. 26G also shows circuit board 2624 mounted to circuit board 2622. Circuit board 2624 includes wireless communications module 2632. In some implementations, wireless communications module 2632 utilizes antenna 2606 for wireless communication (e.g., Wi-Fi communications). FIG. 26G also shows region 2645. In some implementations, an internal antenna, such as a sheet metal antenna or a board antenna, is located in region 2645. In some implementations, an internal antenna is located at another location on circuit board 2622.

[0348] FIG. 26H shows circuit board 2620. Circuit board 2620 includes a plurality of LEDs 2604 (e.g., 30 LEDs), such as LED 2604-1. Circuit board 2620 also includes light sensor 2612. FIG. 26H also shows partition 2652. In some implementations, partition 2652 is affixed to circuit board 2620. In some implementations, partition 2652 prevents light from LEDs 2604 from directly entering lens 2602. In some implementations, an internal antenna is located on circuit board 2620.

[0349] FIG. 26I shows a first side of circuit board 2634 and lens 2602. In some implementations, lens 2602 is mounted on circuit board 2634. FIG. 26I also shows region 2647. In some implementations, an internal antenna, such as a chip antenna or a board antenna, is located in region 2647. In some implementations, an internal antenna is located at another location on circuit board 2634.

[0350] FIG. 26J shows a second side of circuit board 2634. FIG. 26J also shows region 2649. In some implementations, an internal antenna, such as a chip antenna or a sheet metal antenna, is located in region 2649. In some implementations, an internal antenna is located at another location on circuit board 2634.

[0351] In some implementations, camera device 2600 includes multiple antennas and each antenna is coupled to a distinct communications module. For example, antenna 2606 is coupled to a first communications module for use with Wi-Fi communications and an internal antenna is coupled to a second communications module for use with Bluetooth communications. In some implementations, the camera device 2600 includes a controller module to manage operations of the first and second communications modules. In some implementations, one or more of the arbitration methods and/or schemes described herein (e.g., as discussed above with respect to FIG. 15A) are utilized to manage operations between communications modules, radios, and/or antennas. In some implementations, one or more of the co-existence methods and/or circuits described herein (e.g., as discussed above with respect to FIG. 16) are utilized to manage operations between communications modules,



radios, and/or antennas. In some implementations, camera device 2600 includes an antenna coupled to multiple communications modules. In some implementations, camera device 2600 includes multiple antennas coupled to a single communications module (e.g., wireless communications module 2632).

[0352] In some implementations, a communications module is located in at least one of regions 2623, 2633, and 2635 (FIG. 26D). In some implementations, a communications module is located in region 2647 (FIG. 26E). In some implementations, a communications module is located in region 2645 (FIG. 26G). In some implementations, a communications module is located in region 2649 (FIG. 26J). In some implementations, a communications module is located at another position within camera device 2600. For example, camera device 2600 includes a first antenna (e.g., external antenna 2606 in FIG. 26A) coupled to a first communications module (e.g., wireless communications module 2632 in FIG. 26G) and a second antenna, such as adhesive antenna (e.g., located in region 2637 in FIG. 26D), coupled to a second communications module (e.g., located in region 2635 in FIG. 26D). As another example, camera device 2600 includes a first antenna (e.g., external antenna 2606 in FIG. 26A) coupled to a first communications module (e.g., wireless communications module 2632 in FIG. 26G) and a second antenna, such as a chip antenna (e.g., located in region 2623 in FIG. 26D), coupled to a second communications module (e.g., located in region 2645 in FIG. 26G).

[0353] In some implementations, camera device 2600 includes a communications controller for managing communications via multiple antennas and/or multiple radios. In some implementations, the communications controller comprises a communications module (e.g., communications module 942 in FIG. 14). In some implementations, the communications controller is located in region 2623 (FIG. 26F). In some implementations, the communications controller is located in region 2645 (FIG. 26G). In some implementations, the communications controller is located in region 2647 (FIG. 26I). In some implementations, a communications controller is located at another position within camera device 2600. For example, camera device 2600 includes: (1) a first antenna (e.g., external antenna 2606 in FIG. 26A) coupled to a first communications module (e.g., wireless communications module 2632 in FIG. 26G); (2) a second antenna, such as a chip antenna (e.g., located in region 2623 in FIG. 26F), coupled to a second communications module (e.g., located in region 2645 in FIG. 26G); and (3) a communications controller (e.g., located in region 2647 in FIG. 26I).

[0354] FIGS. 27A-27I illustrate various assembly views of a camera device, in accordance with some implementations. FIG. 27A shows an exterior view of camera device 2700 including casing 2701, lens 2702, motion sensor 2708, sensors 2706, microphone 2710, siren 2704, and stand 2703. In some implementations, casing 2701 comprises a plastic casing. In some implementations, stand 2703 comprises a metal stand. In some implementations, stand 2703 comprises a plastic stand. In some implementations, camera device 2700 includes one or more LEDs. In some implementations camera device 2700 includes one or more IR LEDs. In some implementations, camera device 2700 includes one or more speakers. In some implementations, siren 2704 is used to send alerts to nearby persons. In some implementations, sensors 2706 include one or more of: a light sensor, a

humidity sensor, and a temperature sensor. In some implementations, camera device 2700 switches between color mode and infrared mode based on output from sensors 2706. In some implementations, LEDs are utilized to provide illumination when camera device 2700 is in infrared mode. In some implementations, microphone 2710 is utilized to detect noise above a predefined threshold. In some implementations, microphone 2710 is utilized to receive voice commands. In some implementations, camera device 2700 includes one or more external antennas.

[0355] FIG. 27B shows an exterior view of a side of camera device 2700 including casing 2701, lens 2702, motion sensor 2708, and stand 2703. FIG. 27B also shows region 2705 on casing 2701. In some implementations, camera device 2700 includes one or more external antennas (e.g., external antenna 2402, FIG. 24A). In some implementations, an external antenna is located in region 2705. In some implementations, an external antenna is located at another position on camera device 2700. In some implementations, the one or more external antennas are utilized with one or more of a variety of custom or standard wireless protocols (e.g., IEEE 802.15.4, Wi-Fi, ZigBee, 6LoWPAN, Thread, Z-Wave, Bluetooth Smart, ISA100.11a, WirelessHART, MiWi, etc.).

[0356] FIGS. 27C and 27D show additional exterior views of camera device 2700. FIG. 27C shows an exterior view of the back of camera device 2700 including casing 2701, siren 2704, speaker 2714, reset affordance 2712, and stand 2703. In some implementations, reset affordance 2712 is utilized to reset camera device 2700 to a known state. FIG. 27D shows an exterior view of the back of camera device 2700 with stand 2703 removed. In FIG. 27D camera device 2700 includes casing 2701, siren 2704, speaker 2714, reset affordance 2712, battery compartment 2716, and power port 2718. In some implementations, battery compartment 2716 is utilized to couple batteries to provide power to camera device 2700.

[0357] FIG. 27E shows an interior view of camera device 2700 including casing 2701, circuit board 2720, siren 2704, and speaker 2714. Circuit board 2720 includes reset button 2726, antenna 2722, and wireless communications module 2707. In some implementations, wireless communications module 2707 comprises a wireless communications chip mounted on board 2720. In some implementations, antenna 2722 comprises a chip antenna (e.g., antenna 2422 in FIG. 24D). In some implementations, antenna 2722 comprises a silicon chip antenna. In some implementations, antenna 2722 is utilized with Wi-Fi and/or Bluetooth wireless communications. In some implementations, antenna 2722 is utilized with 15.4 wireless communications. In some implementations, an external antenna (e.g., an external antenna located in region 2705 in FIG. 27D) is utilized for 15.4 wireless communications and antenna 2722 is utilized with Wi-Fi communications. In some implementations, an external antenna is utilized for Bluetooth communications and antenna 2722 used for Wi-Fi communications.

[0358] FIG. 27E also shows regions 2709, 2711, 2713, 2715, 2717, and 2719 on casing 2701, and 2721 on circuit board 2720. In some implementations, camera device 2700 includes one or more internal antennas in addition to antenna 2722. In some implementations, the one or more additional internal antennas include a sheet metal antenna (e.g., antenna 2404 in FIG. 24B). In some implementations, the one or more internal antennas include a board antenna (e.g.,

antenna 2414 in FIG. 24C). In some implementations, the one or more internal antennas include a chip antenna (e.g., antenna 2422 in FIG. 24D). In some implementations, the one or more internal antennas include an adhesive antenna (e.g., antenna 1104-1 in FIG. 11D).

[0359] In some implementations, an internal antenna, such as an adhesive antenna, is located in region 2709. In some implementations, an internal antenna, such as an adhesive antenna, is located in at least one of regions 2711, 2713, 2715, 2717, and 2719. In some implementations, an internal antenna, such as a board antenna, is located in region 2721. In some implementations, an internal antenna is located at another position within camera device 2700. In some implementations, the one or more additional internal antennas are utilized with one or more of a variety of custom or standard wireless protocols (e.g., IEEE 802.15.4, Wi-Fi, ZigBee, 6LoWPAN, Thread, Z-Wave, Bluetooth Smart, ISA100.11a, WirelessHART, MiWi, etc.). In some implementations, an additional internal antenna is utilized for 15.4 wireless communications and antenna 2722 is utilized for Wi-Fi communications. In some implementations, wireless communications module 2707 utilizes antenna 2722 for wireless communication (e.g., Wi-Fi communications).

[0360] FIG. 27F shows a first side of circuit board 2720. The first side of circuit board 2720 includes antenna 2722, wireless communications module 2707, and power port 2718, and reset button 2726. FIG. 27F also shows region 2721. In some implementations, an internal antenna, such as a chip antenna or a board antenna, is located in region 2721. In some implementations, an internal antenna is located at another location on circuit board 2720.

[0361] FIG. 27G shows a second side of circuit board 2720. The second side of circuit board 2720 includes memory 2731 and image sensor 2708. In some implementations, image sensor 2708 is coupled to lens 2702 (FIG. 27A). In some implementations, memory 2731 comprises NAND memory. In some implementations, memory 2731 comprises flash memory. FIG. 27G also shows regions 2723, 2725, 2727, and 2729. In some implementations, an internal antenna, such as a sheet metal antenna or a board antenna, is located in at least one of regions 2723, 2725, 2727, and 2729. In some implementations, an internal antenna is located at another location on circuit board 2720. In some implementations, the internal antenna is utilized with one or more of a variety of custom or standard wireless protocols (e.g., IEEE 802.15.4, Wi-Fi, ZigBee, 6LoWPAN, Thread, Z-Wave, Bluetooth Smart, ISA100.11a, WirelessHART, MiWi, etc.).

[0362] FIGS. 27H-27I shows interior views of camera device 2700 including casing 2701, circuit board 2730, and lens 2702. In some implementations, circuit board 2730 includes motion sensor 2708 (FIG. 27A). In some implementations, an internal antenna is located on circuit board 2730 (e.g., in region 2715). FIGS. 27H-27I also show regions 2713, 2717, 2721, and 2733 on casing 2701. In some implementations, an internal antenna, such as an adhesive antenna, is located in at least one of regions 2713, 2717, 2721, and 2733. In some implementations, an internal antenna, such as a chip antenna, is located in region 2715. In some implementations, an internal antenna is located at another position within camera device 2700. In some implementations, the internal antenna is utilized with one or more of a variety of custom or standard wireless protocols (e.g., IEEE 802.15.4, Wi-Fi, ZigBee, 6LoWPAN, Thread,

Z-Wave, Bluetooth Smart, ISA100.11a, WirelessHART, MiWi, etc.). In some implementations, an internal antenna at one of these locations is utilized for Bluetooth wireless communications and antenna 2722 (FIG. 27F) is utilized for Wi-Fi communications. In some implementations, an internal antenna at one of these locations is utilized for 15.4 wireless communications and antenna 2722 (FIG. 27F) is utilized for Wi-Fi communications.

[0363] In some implementations, camera device 2700 includes multiple antennas and each antenna is coupled to a distinct communications module. For example, antenna 2722 is coupled to a first communications module for use with Wi-Fi communications and an external antenna is coupled to a second communications module for use with Bluetooth communications. In some implementations, the camera device 2700 includes a controller module to manage operations of the first and second communications modules. In some implementations, one or more of the arbitration methods and/or schemes described herein (e.g., as discussed above with respect to FIG. 15A) are utilized to manage operations between communications modules, radios, and/or antennas. In some implementations, one or more of the co-existence methods and/or circuits described herein (e.g., as discussed above with respect to FIG. 16) are utilized to manage operations between communications modules, radios, and/or antennas. In some implementations, camera device 2700 includes an antenna coupled to multiple communications modules. In some implementations, camera device 2700 includes multiple antennas coupled to a single communications module (e.g., wireless communications module 2707).

[0364] In some implementations, a communications module is located in region 2721 (FIG. 27E). In some implementations, a communications module is located in at least one of regions 2723, 2725, 2727, and 2729 (FIG. 27G). In some implementations, a communications module is located in region 2715 (FIG. 27H). In some implementations, a communications module is located at another position within camera device 2700. For example, camera device 2700 includes a first antenna (e.g., antenna 2722 in FIG. 27F) coupled to a first communications module (e.g., wireless communications module 2707 in FIG. 27F) and a second antenna, such as adhesive antenna (e.g., located in region 2709 in FIG. 27E), coupled to a second communications module (e.g., located in region 2721 in FIG. 27E). As another example, camera device 2700 includes a first antenna (e.g., antenna 2722 in FIG. 27F) coupled to a first communications module (e.g., wireless communications module 2707 in FIG. 27F) and a second antenna, such as a chip antenna (e.g., located in region 2723 in FIG. 27G), coupled to a second communications module (e.g., located in region 2725 in FIG. 27G).

[0365] In some implementations, camera device 2700 includes a communications controller for managing communications via multiple antennas and/or multiple radios. In some implementations, the communications controller comprises a communications module (e.g., communications module 942 in FIG. 14). In some implementations, the communications controller is located in region 2721 (FIG. 27F). In some implementations, the communications controller is located in at least one of regions 2723, 2725, 2727, and 2728 (FIG. 27G). In some implementations, the communications controller is located in region 2715 (FIG. 27H). In some implementations, a communications controller is

located at another position within camera device 2700. For example, camera device 2700 includes: (1) a first antenna (e.g., antenna 2722 in FIG. 27F) coupled to a first communications module (e.g., wireless communications module 2707 in FIG. 27F); (2) a second antenna, such as a chip antenna (e.g., located in region 2715 in FIG. 27H), coupled to a second communications module (e.g., located in region 2727 in FIG. 27G); and (3) a communications controller (e.g., located in region 2729 in FIG. 27G).

[0366] FIGS. 28A-28N illustrate various assembly views of a camera device, in accordance with some implementations. FIG. 28A shows an exterior view of camera device 2800 including casing 2801, casing 2803, casing 2805, lens 2808, LEDs 2806, light sensor 2804, speaker 2802, and microphone 2810. In some implementations, at least one of casings 2801, 2803, and 2805 comprise a plastic casing. In some implementations, camera device 2800 includes one or more additional sensors, such as a motion sensor, a humidity sensor, and a temperature sensor. In some implementations, camera device 2800 switches between color mode and infrared mode based on output from light sensor 2804. In some implementations, LEDs 2806 are utilized to provide illumination when camera device 2800 is in infrared mode. In some implementations, microphone 2810 is utilized to detect noise above a predefined threshold. In some implementations, microphone 2810 is utilized to receive voice commands.

[0367] FIG. 28A also shows regions 2807 and 2809 on casing 2801. In some implementations, camera device 2800 includes one or more external antennas (e.g., external antenna 2402, FIG. 24A). In some implementations, an external antenna is located in region 2807. In some implementations, an external antenna is located in region 2809. In some implementations, an external antenna is located at another position on camera device 2800.

[0368] FIG. 28B shows an exterior view of camera device 2811 including casing 2813, casing 2815, casing 2817, lens 2816, LEDs 2814, light sensor 2812, and microphone 2818. In some implementations, camera device 2811 includes one or more of the components of camera device 2800. In some implementations, the functionality of camera device 2811 includes all of the functionality of camera device 2800. In some implementations, camera device 2811 includes one or more speakers. In some implementations, camera device 2811 includes one or more additional sensors, such as a motion sensor, a humidity sensor, and a temperature sensor. In some implementations, camera device 2811 switches between color mode and infrared mode based on output from light sensor 2812. In some implementations, LEDs 2814 are utilized to provide illumination when camera device 2811 is in infrared mode. In some implementations, microphone 2818 is utilized to detect noise above a predefined threshold. In some implementations, microphone 2818 is utilized to receive voice commands. In some implementations, camera device 2811 includes one or more external antennas.

[0369] FIG. 28C shows a mount for use with camera device 2800 or camera device 2811. Mount 2820 includes adjuster 2822 for adjusting the orientation of an attached camera device. In some implementations, mount 2820 comprises a plastic mount. In some implementations, mount 2820 comprises a metal mount.

[0370] FIG. 28D shows an additional exterior view of camera device 2800. FIG. 28B shows an exterior view of the

back of camera device 2800 including casing 2801, casing 2803, casing 2805, power port 2816, communications port 2814, antenna port 2812, and audio ports 2818. In some implementations, communications port 2814 is an Ethernet port. Antenna port 2812 is utilized to couple an external antenna (e.g., external antenna 2402, FIG. 24A) to camera device 2800. In some implementations, antenna port 2812 and an external antenna are utilized with one or more of a variety of custom or standard wireless protocols (e.g., IEEE 802.15.4, Wi-Fi, ZigBee, 6LoWPAN, Thread, Z-Wave, Bluetooth Smart, ISA100.11a, WirelessHART, MiWi, etc.). In some implementations, antenna port 2812 and an external antenna are utilized with Wi-Fi and/or Bluetooth wireless communications. In some implementations, antenna port 2812 and an external antenna are utilized with 15.4 wireless communications. In some implementations, an internal antenna is utilized for 15.4 wireless communications and antenna port 2812 and an external antenna are utilized with Wi-Fi communications. In some implementations, an internal antenna is utilized for Bluetooth communications and antenna port 2812 and an external antenna are used for Wi-Fi communications.

[0371] FIG. 28D also shows regions 2807 and 2809 on casing 2801, region 2819 on casing 2803, and region 2821 on casing 2805. In some implementations, camera device 2800 includes one or more additional external antennas (e.g., external antenna 2402, FIG. 24A) in addition to an external antenna coupled to antenna port 2812. In some implementations, an external antenna is located in at least one of regions 2807, 2809, 2819, and 2821. For example, an antenna port similar in design to antenna port 2812 is located in region 2821 and an external antenna is coupled to each antenna port. In some implementations, antenna port 2812 and an external antenna utilized for communications at a first wavelength and the one or more additional external antennas are utilized for communications at one or more wavelengths distinct from the first wavelength. For example, the additional external antenna is utilized for 15.4 wireless communications and an external antenna coupled to antenna port 2812 is utilized for Wi-Fi communications. In some implementations, an external antenna is located at another position on camera device 2800.

[0372] FIG. 28E shows an internal view of camera device 2800. FIG. 28E shows casing 2801 de-coupled from casing 2805. FIG. 28E also shows gear 2830 for rotating the point of view of camera device 2800 in conjunction with a motor.

[0373] FIG. 28F shows an internal view of camera device 2800. FIG. 28F shows the interior of casing 2805. FIG. 28F also shows antenna port 2812, circuit board 2836, and microphone 2823. Circuit board 2836 includes memory 2832 (e.g., SRAM) and processor 2834 (e.g., ARM microcontroller). FIG. 28F also shows regions 2825, 2827, 2829, 2831, 2833, 2835, and 2837 on casing 2805, regions 2839, 2841, and 2843 on circuit board 2836. In some implementations, camera device 2800 includes one or more internal antennas. In some implementations, the one or more internal antennas include a sheet metal antenna (e.g., antenna 2404 in FIG. 24B). In some implementations, the one or more internal antennas include a board antenna (e.g., antenna 2414 in FIG. 24C). In some implementations, the one or more internal antennas include a chip antenna (e.g., antenna 2422 in FIG. 24D). In some implementations, the one or more internal antennas include an adhesive antenna (e.g., antenna 1104-1 in FIG. 11D).

[0374] In some implementations, an internal antenna, such as an adhesive antenna, is located in region 2825. In some implementations, an internal antenna, such as an adhesive antenna, is located in at least one of regions 2827, 2829, 2831, 2833, 2835, and 2837. In some implementations, an internal antenna, such as a chip antenna, is located in region 2839. In some implementations, an internal antenna, such as a board antenna, is located in region 2841. In some implementations, an internal antenna, such as a sheet metal antenna, is located in region 2843. In some implementations, an internal antenna is located at another position on circuit board 2836. In some implementations, an internal antenna is located at another position within camera device 2800. In some implementations, the internal antenna is utilized with one or more of a variety of custom or standard wireless protocols (e.g., IEEE 802.15.4, Wi-Fi, ZigBee, 6LoWPAN, Thread, Z-Wave, Bluetooth Smart, ISA100.11a, WirelessHART, MiWi, etc.). In some implementations, the internal antenna is utilized for 15.4 wireless communications and an external antenna coupled to antenna port 2812 is utilized for Wi-Fi communications.

[0375] FIG. 28G shows a first side of circuit board 2836. The first side of circuit board 2836 includes memory 2832 and processor 2834. FIG. 28G also shows regions 2839, 2841, and 2843. In some implementations, an internal antenna, such as a chip antenna or a board antenna, is located in at least one of regions 2839, 2841, and 2843. In some implementations, an internal antenna is located at another location on circuit board 2836.

[0376] FIG. 28H shows a second side of circuit board 2836. The second side of circuit board 2836 includes audio ports 2818, communications port 2814, power port 2816, and LED 2846. In some implementations, LED 2846 is utilized to indicate a status of camera device 2800. FIG. 28H also shows circuit board 2842 mounted on circuit board 2836. Circuit board 2842 includes wireless communications module 2838 and antenna connector 2844 for coupling communications module 2838 to an external antenna coupled to antenna port 2812 (FIG. 28F). In some implementations, wireless communications module 2838 utilizes an external antenna coupled to antenna port 2812 (FIG. 28F) for wireless communication (e.g., Wi-Fi communications).

[0377] FIG. 28H also shows regions 2845 and 2847. In some implementations, an internal antenna, such as a sheet metal antenna, is located in region 2845. In some implementations, an internal antenna, such as a chip antenna, is located in region 2847. In some implementations, an internal antenna is located at another location on circuit board 2836.

[0378] FIG. 28I shows circuit board 2842 including wireless communications module 2838 and antenna connector 2844. In some implementations, wireless communications module 2838, via antenna connector 2844, utilizes an external antenna coupled to antenna port 2812 (FIG. 28F) for wireless communication (e.g., Bluetooth communications).

[0379] FIGS. 28J-28K show interior views of camera device 2800 where a portion of casing 2803 is de-coupled from casing 2801. FIG. 28J also shows motor 2848 for rotating the point of view of camera device 2800 in conjunction with one or more gears. FIGS. 28J-29K also show circuit board 2846 mounted within casing 2803. In some implementations, circuit board 2846 includes an image sensor coupled to lens 2808 (FIG. 28A). In some implementations, circuit board 2846 is coupled to LEDs 2806 (FIG. 28A). FIGS. 28J-28K also show regions 2807 and

2809. In some implementations, camera device 2800 includes one or more external antennas located within region 2807 and or 2809.

[0380] FIG. 28L shows a first side of circuit board 2846. The first side of circuit board 2846 includes sensor controller 2847. FIG. 28M shows a second side of circuit board 2846. The second side of circuit board 2846 includes image sensor 2850. In some implementations, image sensor 2850 is coupled to lens 2808 (FIG. 28A) and sensor controller 2847 (FIG. 28L). FIG. 28M also shows regions 2849, 2851, and 2853 on circuit board 2846. In some implementations, an internal antenna, such as a sheet metal antenna, is located in region 2849. In some implementations, an internal antenna, such as a chip antenna, is located in region 2851. In some implementations, an internal antenna, such as a board antenna, is located in region 2853. In some implementations, an internal antenna is located at another location on circuit board 2846.

[0381] FIG. 28N shows lens 2834 coupled to board 2846 (e.g., coupled to image sensor 2850 of circuit board 2846). FIG. 28N also shows LEDs 2806 mounted on circuit board 2852 and circuit board 2852 coupled to circuit board 2846.

[0382] In some implementations, camera device 2800 (and/or camera device 2811) includes multiple antennas and each antenna is coupled to a distinct communications module. For example, an external antenna is coupled to a first communications module via antenna port 2812 for use with Wi-Fi communications and an internal antenna is coupled to a second communications module for use with Bluetooth communications. In some implementations, the camera device 2800 includes a controller module to manage operations of the first and second communications modules. In some implementations, one or more of the arbitration methods and/or schemes described herein (e.g., as discussed above with respect to FIG. 15A) are utilized to manage operations between communications modules, radios, and/or antennas. In some implementations, one or more of the co-existence methods and/or circuits described herein (e.g., as discussed above with respect to FIG. 16) are utilized to manage operations between communications modules, radios, and/or antennas. In some implementations, camera device 2800 includes an antenna coupled to multiple communications modules. In some implementations, camera device 2800 includes multiple antennas coupled to a single communications module (e.g., wireless communications module 2838, FIG. 28H).

[0383] In some implementations, a communications module is located in at least one of regions 2839, 2841, and 2843 (FIG. 28F). In some implementations, a communications module is located in at least one of regions 2845 and 2847 (FIG. 28H). In some implementations, a communications module is located at another position on circuit board 2836. In some implementations, a communications module is located in at least one of regions 2849, 2851, and 2853 (FIG. 28M). In some implementations, a communications module is located at another position on circuit board 2846. In some implementations, a communications module is located at another position within camera device 2800. For example, camera device 2800 includes a first antenna (e.g., an exterior antenna coupled to antenna port 2812 in FIG. 28F) coupled to a first communications module (e.g., wireless communications module 2838, FIG. 28H) and a second antenna, such as adhesive antenna (e.g., located in region 2825 in FIG. 28F), coupled to a second communications module (e.g.,

located in region **2841** in FIG. **28F**). As another example, camera device **2800** includes a first antenna (e.g., an exterior antenna coupled to antenna port **2812** in FIG. **28F**) coupled to a first communications module (e.g., wireless communications module **2838**, FIG. **28H**) and a second antenna, such as a chip antenna (e.g., located in region **2851** in FIG. **28M**), coupled to a second communications module (e.g., located in region **2853** in FIG. **28M**).

[**0384**] In some implementations, camera device **2800** (and/or camera device **2811**) includes a communications controller for managing communications via multiple antennas and/or multiple radios. In some implementations, the communications controller comprises a communications module (e.g., communications module **942** in FIG. **14**). In some implementations, the communications controller is located in at least one of regions **2839**, **2841**, and **2843** (FIG. **28F**). In some implementations, the communications controller is located in at least one of regions **2845** and **2847** (FIG. **28H**). In some implementations, a communications controller is located at another position on circuit board **2836**. In some implementations, a communications controller is located in at least one of regions **2849**, **2851**, and **2853** (FIG. **28M**). In some implementations, a communications controller is located at another position on circuit board **2846**. In some implementations, a communications controller is located at another position within camera device **2800**. For example, camera device **2800** includes: (1) a first antenna (e.g., an exterior antenna coupled to antenna port **2812** in FIG. **28F**) coupled to a first communications module (e.g., wireless communications module **2838**, FIG. **28H**); (2) a second antenna, such as a chip antenna (e.g., located in region **2843** in FIG. **28F**), coupled to a second communications module (e.g., located in region **2839** in FIG. **28F**); and (3) a communications controller (e.g., located in region **2841** in FIG. **28F**).

[**0385**] FIGS. **29A-29I** illustrate various assembly views of a camera device, in accordance with some implementations. FIG. **29A** shows an exterior view of camera device **2900** including casing **2901**, lens **2906**, LED **2904**, sensor **2908**, microphone **2902**, and stand **2910**. In some implementations, casing **2901** comprises a plastic casing. In some implementations, stand **2910** comprises a metal stand. In some implementations, sensor **2908** comprises a motion sensor. In some implementations, sensor **2908** comprises a light sensor. In some implementations, camera device **2900** includes one or more additional sensors, such as a motion sensor, a humidity sensor, and a temperature sensor. In some implementations, camera device **2900** switches between color mode and infrared mode based on output from sensor **2908**. In some implementations, LED **2904** is utilized to convey a status of camera device **2900** to nearby persons. In some implementations, camera device **2900** includes a plurality of LEDs (e.g., around lens **2906**). In some implementations, the plurality of LEDs provides illumination when camera device **2900** is in infrared mode. In some implementations, microphone **2902** is utilized to detect noise above a predefined threshold. In some implementations, microphone **2902** is utilized to receive voice commands.

[**0386**] FIG. **29B** shows another exterior view of camera device **2900**. FIG. **29B** shows camera device **2900** including casing **2901**, lens **2906**, LED **2904**, sensor **2908**, microphone **2902**, and stand **2910**. In FIG. **29B** casing **2901** is raised up from stand **2910**, while in FIG. **29A** casing **2901** is nesting within stand **2910**.

[**0387**] FIG. **29C** shows another exterior view of camera device **2900**. FIG. **29C** shows the back of camera device **2900** including setup affordance **2912**, speaker **2914**, and communications port **2916**. In some implementations, communications port **2916** comprises a micro-USB port. In some implementations, setup affordance **2912** is utilized to wirelessly couple camera device **2900** to one or more other electronic devices. In some implementations, setup affordance **2912** is utilized to set camera device **2900** to a known state.

[**0388**] FIG. **29D** shows an interior view of camera device **2900** including casing **2901**, circuit board **2920**, and speaker **2914**. Circuit board **2920** includes setup affordance **2912** and memory **2921**. In some implementations, memory **2921** comprises flash memory.

[**0389**] FIG. **29D** also shows regions **2903**, **2905**, and **2907** on casing **2901**. In some implementations, camera device **2900** includes one or more internal antennas. In some implementations, the one or more internal antennas include an adhesive antenna (e.g., antenna **1104-1** in FIG. **11D**). In some implementations, an internal antenna, such as an adhesive antenna, is located in at least one of regions **2903**, **2905**, **2907**. In some implementations, an internal antenna is located at another position within camera device **2900**. In some implementations, the one or more internal antennas are utilized with one or more of a variety of custom or standard wireless protocols (e.g., IEEE 802.15.4, Wi-Fi, ZigBee, 6LoWPAN, Thread, Z-Wave, Bluetooth Smart, ISA100.11a, WirelessHART, MiWi, etc.).

[**0390**] FIG. **29E** shows a first side of circuit board **2920**. The first side of circuit board **2920** includes memory **2921** setup affordance **2912**, speaker connectors **2940**, and microphone connectors **2942**. FIG. **29F** shows a second side of circuit board **2920**. The second side of circuit board **2920** includes processor **2923**.

[**0391**] FIG. **29G** shows lens **2906**, circuit board **2926**, and circuit board **2928**. Circuit board **2928** includes LEDs **2930** and LED **2904**. In some implementations, LEDs **2930** comprise a plurality of infrared (IR) LEDs. In some implementations, lens **2906** is mounted to circuit board **2926**. In some implementations, antenna connector **2932** is coupled to circuit board **2926**.

[**0392**] FIG. **29H** shows circuit board **2926** including wireless communication module **2936** and antenna connector **2932**. In some implementations, wireless communication module **2936** comprises a wireless communication chip. In some implementations, wireless communications module **2936** utilizes an antenna for wireless communication (e.g., Wi-Fi communications). In some implementations, wireless communication module **2936** is utilized with one or more of a variety of custom or standard wireless protocols (e.g., IEEE 802.15.4, Wi-Fi, ZigBee, 6LoWPAN, Thread, Z-Wave, Bluetooth Smart, ISA100.11a, WirelessHART, MiWi, etc.).

[**0393**] FIG. **29H** also shows regions **2933**, **2935**, and **2937** on circuit board **2926**. In some implementations, camera device **2900** includes one or more internal antennas. In some implementations, the one or more internal antennas include a sheet metal antenna (e.g., antenna **2404** in FIG. **24B**). In some implementations, the one or more internal antennas include a board antenna (e.g., antenna **2414** in FIG. **24C**). In some implementations, the one or more internal antennas include a chip antenna (e.g., antenna **2422** in FIG. **24D**).

[0394] In some implementations, an internal antenna, such as a chip antenna, is located in region 2933. In some implementations, an internal antenna, such as a board antenna, is located in region 2935. In some implementations, an internal antenna, such as a sheet metal antenna, is located in region 2937. In some implementations, an internal antenna is located at another position on circuit board 2926. In some implementations, the one or more internal antennas are utilized with one or more of a variety of custom or standard wireless protocols (e.g., IEEE 802.15.4, Wi-Fi, ZigBee, 6LoWPAN, Thread, Z-Wave, Bluetooth Smart, ISA100.11a, WirelessHART, MiWi, etc.). In some implementations, a first internal antenna is utilized for 15.4 wireless communications and a second internal antenna is utilized for Wi-Fi communications.

[0395] FIG. 29I shows an interior view of camera device 2900. FIG. 29I shows casing 2901 with antenna 2946. In some implementations, antenna 2946 comprises an adhesive antenna (e.g., antenna 1104-1 in FIG. 11D). In some implementations, antenna 2946 is utilized with Wi-Fi and/or Bluetooth wireless communications. In some implementations, antenna 2946 is utilized with 15.4 wireless communications. In some implementations, antenna 2946 is coupled to wireless communication module 2936 via antenna connector 2932. In some implementations, another internal antenna (e.g., an adhesive antenna located in region 2905 in FIG. 29D) is utilized for 15.4 wireless communications and antenna 2946 is utilized with Wi-Fi communications. In some implementations, an additional internal antenna is utilized for Bluetooth communications and antenna 2946 used for Wi-Fi communications.

[0396] FIG. 29I also shows regions 2947 and 2949 on casing 2901. In some implementations, camera device 2900 includes one or more internal antennas in addition to antenna 2946. In some implementations, the one or more additional internal antennas include an adhesive antenna (e.g., antenna 1104-1 in FIG. 11D). In some implementations, an internal antenna, such as an adhesive antenna, is located in at least one of regions 2947 and 2949. In some implementations, an internal antenna is located at another position within camera device 2900. In some implementations, the one or more additional internal antennas are utilized with one or more of a variety of custom or standard wireless protocols (e.g., IEEE 802.15.4, Wi-Fi, ZigBee, 6LoWPAN, Thread, Z-Wave, Bluetooth Smart, ISA100.11a, WirelessHART, MiWi, etc.). For example, antenna 2946 is utilized with Wi-Fi communications and a second internal antenna (e.g., located in region 2949) is utilized with 15.4 communications.

[0397] In some implementations, camera device 2900 includes multiple antennas and each antenna is coupled to a distinct communications module. For example, antenna 2932 is coupled to a first communications module for use with Wi-Fi communications and a second internal antenna is coupled to a second communications module for use with Bluetooth communications. In some implementations, the camera device 2900 includes a controller module to manage operations of the first and second communications modules. In some implementations, one or more of the arbitration methods and/or schemes described herein (e.g., as discussed above with respect to FIG. 15A) are utilized to manage operations between communications modules, radios, and/or antennas. In some implementations, one or more of the co-existence methods and/or circuits described herein (e.g.,

as discussed above with respect to FIG. 16) are utilized to manage operations between communications modules, radios, and/or antennas. In some implementations, camera device 2900 includes an antenna coupled to multiple communications modules. In some implementations, camera device 2900 includes multiple antennas coupled to a single communications module (e.g., wireless communications module 2936). For example, antenna 2946 and a second antenna (e.g., an adhesive antenna located in region 2947 of FIG. 29I) are both coupled to wireless communications module 2936 (FIG. 29H).

[0398] In some implementations, a communications module is located in at least one of regions 2933, 2935, and 2937 of circuit board 2926 (FIG. 29H). In some implementations, a communications module is located at another location on circuit board 2926. In some implementations, a communications module is located at another position within camera device 2900. For example, camera device 2900 includes a first antenna (e.g., antenna 2946 in FIG. 29I) coupled to a first communications module (e.g., wireless communications module 2936 in FIG. 29H) and a second antenna, such as adhesive antenna (e.g., located in region 2903 in FIG. 29D), coupled to a second communications module (e.g., located in region 2933 in FIG. 29H). As another example, camera device 2900 includes a first antenna (e.g., antenna 2946 in FIG. 29I) coupled to a first communications module (e.g., wireless communications module 2936 in FIG. 29H) and a second antenna, such as a chip antenna (e.g., located in region 2933 in FIG. 29H), coupled to a second communications module (e.g., located in region 2937 in FIG. 29H).

[0399] In some implementations, camera device 2900 includes a communications controller for managing communications via multiple antennas and/or multiple radios. In some implementations, the communications controller comprises a communications module (e.g., communications module 942 in FIG. 14). In some implementations, the communications controller is located in at least one of regions 2933, 2935, and 2937 (FIG. 29H). In some implementations, a communications controller is located at another position within camera device 2900. For example, camera device 2900 includes: (1) a first antenna (e.g., antenna 2946 in FIG. 29I) coupled to a first communications module (e.g., wireless communications module 2936 in FIG. 29H); (2) a second antenna, such as an adhesive antenna (e.g., located in region 2947 in FIG. 29I), coupled to a second communications module (e.g., located in region 2937 in FIG. 29H); and (3) a communications controller (e.g., located in region 2933 in FIG. 29H).

[0400] For situations in which the systems discussed above collect information about users, the users may be provided with an opportunity to opt in/out of programs or features that may collect personal information (e.g., information about a user's preferences or usage of a smart device). In addition, in some implementations, certain data may be anonymized in one or more ways before it is stored or used, so that personally identifiable information is removed. For example, a user's identity may be anonymized so that the personally identifiable information cannot be determined for or associated with the user, and so that user preferences or user interactions are generalized (for example, generalized based on user demographics) rather than associated with a particular user.

[0401] Although some of various drawings illustrate a number of logical stages in a particular order, stages that are

not order dependent may be reordered and other stages may be combined or broken out. While some reordering or other groupings are specifically mentioned, others will be obvious to those of ordinary skill in the art, so the ordering and groupings presented herein are not an exhaustive list of alternatives. Moreover, it should be recognized that the stages could be implemented in hardware, firmware, software or any combination thereof.

**[0402]** It will also be understood that, although the terms first, second, etc. are, in some instances, used herein to describe various elements, these elements should not be limited by these terms. These terms are only used to distinguish one element from another. For example, a first type of signal could be termed a second type of signal, and, similarly, a second type of signal could be termed a first type of signal, without departing from the scope of the various described implementations. The first type of signal and the second type of signal are both types of signals, but they are not the same type of signal.

**[0403]** The terminology used in the description of the various described implementations herein is for the purpose of describing particular implementations only and is not intended to be limiting. As used in the description of the various described implementations and the appended claims, the singular forms “a”, “an” and “the” are intended to include the plural forms as well, unless the context clearly indicates otherwise. It will also be understood that the term “and/or” as used herein refers to and encompasses any and all possible combinations of one or more of the associated listed items. It will be further understood that the terms “includes,” “including,” “comprises,” and/or “comprising,” when used in this specification, specify the presence of stated features, integers, steps, operations, elements, and/or components, but do not preclude the presence or addition of one or more other features, integers, steps, operations, elements, components, and/or groups thereof.

**[0404]** As used herein, the term “if” is, optionally, construed to mean “when” or “upon” or “in response to determining” or “in response to detecting” or “in accordance with a determination that,” depending on the context. Similarly, the phrase “if it is determined” or “if [a stated condition or event] is detected” is, optionally, construed to mean “upon determining” or “in response to determining” or “upon detecting [the stated condition or event]” or “in response to detecting [the stated condition or event]” or “in accordance with a determination that [a stated condition or event] is detected,” depending on the context.

**[0405]** The foregoing description, for purpose of explanation, has been described with reference to specific implementations. However, the illustrative discussions above are not intended to be exhaustive or to limit the scope of the claims to the precise forms disclosed. Many modifications and variations are possible in view of the above teachings. The implementations were chosen in order to best explain the principles underlying the claims and their practical applications, to thereby enable others skilled in the art to best use the implementations with various modifications as are suited to the particular uses contemplated.

What is claimed is:

1. A camera assembly, comprising:  
an enclosed housing;

a lens module located within the enclosed housing and configured to receive light via a front surface of the camera assembly;

one or more circuit boards positioned within the enclosed housing;

communication circuitry coupled to the one or more circuit boards and configured to wirelessly communicate over a plurality of different communication protocols, the communication circuitry including one or more transceivers configured for communication over a first communication protocol and a second communication protocol;

a first antenna arranged at a first location on the one or more circuit boards, the first antenna configured for communication over the first communication protocol; and

a second antenna arranged at a second location on the one or more circuit boards, the second antenna configured for communication over the second communication protocol.

2. The camera assembly of claim 1, wherein the first antenna and the second antenna are arranged on a same circuit board of the one or more circuit boards.

3. The camera assembly of claim 1, wherein the first antenna and the second antenna are arranged on distinct circuit boards of the one or more circuit boards.

4. The camera assembly of claim 1, wherein the first antenna and the second antenna are configured to operate at a same frequency.

5. The camera assembly of claim 1, wherein the first antenna and the second antenna are configured to operate at different frequencies.

6. The camera assembly of claim 1, wherein the communication circuitry includes a first circuit configured for communication over the first communication protocol and a second circuit configured for communication over the second communication protocol, wherein the first circuit and the second circuit are distinct.

7. The camera assembly of claim 1, wherein the communication circuitry is an integrated circuit configured for communication over both the first and second communication protocols.

8. The camera assembly of claim 1, wherein the communication circuitry is configured to wireless communicate over at least three different communication protocols.

9. The camera assembly of claim 8, wherein the second antenna is further configured for communication over a third communication protocol.

10. The camera assembly of claim 9, wherein:

the first antenna is configured to transmit and receive, over the first communication protocol, signals comprising one or more of alerts, control signals and status information to and from a smart home device; and

the second antenna is configured to transmit and receive, over the second communication protocol, signals for configuring the smart home device, and, over the third communication protocol, data corresponding to video captured by the smart home device.

11. The camera assembly of claim 1, wherein the communication circuitry is further configured to provide transmission access for communicating over the first communication protocol while denying transmission access for communicating over the second communication protocol, in accordance with detecting an activated priority control signal.

12. The camera assembly of claim 1, wherein the first antenna has a first orientation and the second antenna has a

second orientation such that the impact from the presence and interference of each other antenna is inhibited.

**13.** The camera assembly of claim **1**, wherein the first antenna or the second antenna is configured to transmit and receive wireless signals in a wireless local area network according to the IEEE 802.11 specifications.

**14.** The camera assembly of claim **1**, wherein the first antenna or the second antenna is configured to transmit and receive wireless signals in a wireless personal area network according to the IEEE 802.15.4 standard.

**15.** The camera assembly of claim **1**, wherein the first antenna or the second antenna is configured to transmit and receive wireless signals according to the Bluetooth Low Energy standard.

**16.** The camera assembly of claim **1**, wherein the first antenna and the second antenna are electrically coupled to a duplex that controls their connections to a single wireless receiver circuit.

**17.** The camera assembly of claim **1**, wherein video data captured by the lens module is exchanged between the camera assembly and a remote server using a wireless local area network.

\* \* \* \* \*