



US 20160301433A1

(19) **United States**

(12) **Patent Application Publication**  
**Chen**

(10) **Pub. No.: US 2016/0301433 A1**

(43) **Pub. Date: Oct. 13, 2016**

(54) **DETECTOR GENERATING A  
DISPLACEMENT SIGNAL BY INJECTION  
LOCKING AND INJECTION PULLING**

*H03L 7/08* (2006.01)

*H04L 1/00* (2006.01)

(52) **U.S. Cl.**

CPC ..... *H04B 1/10* (2013.01); *H04L 1/0053*  
(2013.01); *H03L 7/099* (2013.01); *H03L*  
*7/0802* (2013.01)

(71) Applicant: **RichWave Technology Corp.**, Taipei  
City (TW)

(72) Inventor: **Tse-Peng Chen**, Taipei City (TW)

(57) **ABSTRACT**

A detector includes an oscillation source, a frequency multiplier, a transceiver and a demodulator. The oscillation source generates a first injection signal with a first frequency. The frequency multiplier receives the first injection signal, outputs an output signal and receives a second injection signal with a second frequency. The frequency multiplier uses injection locking to lock a frequency of the output signal at a multiple of the first frequency, and uses injection pulling to pull the frequency of the output signal to the second frequency. The transceiver transmits the output signal and receives a received signal with a third frequency for updating the second injection signal. The demodulator performs a demodulation operation according to the output signal so as to generate a displacement signal.

(21) Appl. No.: **15/076,685**

(22) Filed: **Mar. 22, 2016**

(30) **Foreign Application Priority Data**

Apr. 8, 2015 (TW) ..... 104111323

**Publication Classification**

(51) **Int. Cl.**  
*H04B 1/10* (2006.01)  
*H03L 7/099* (2006.01)

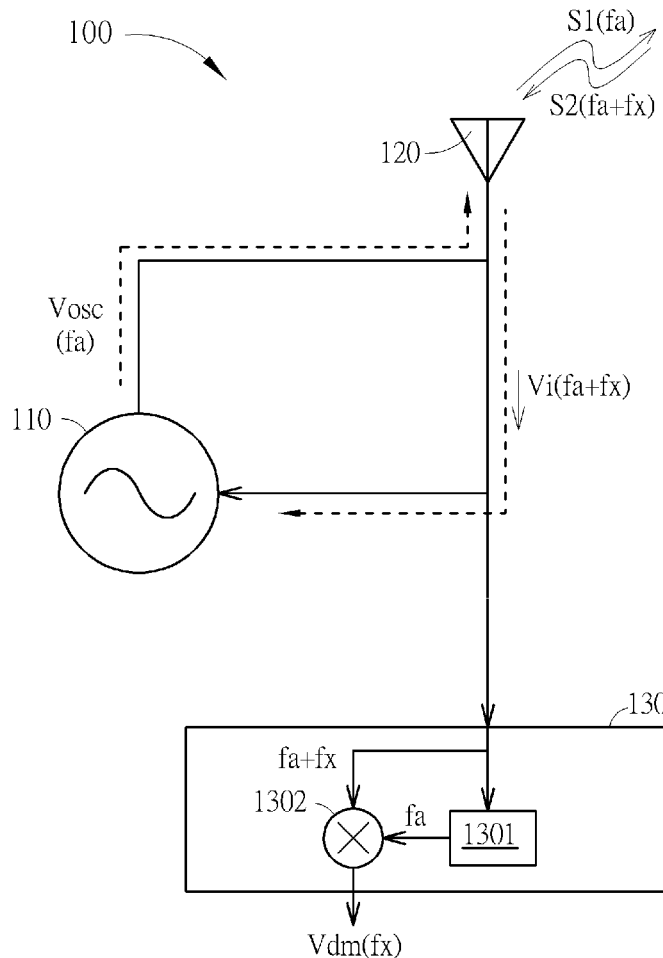

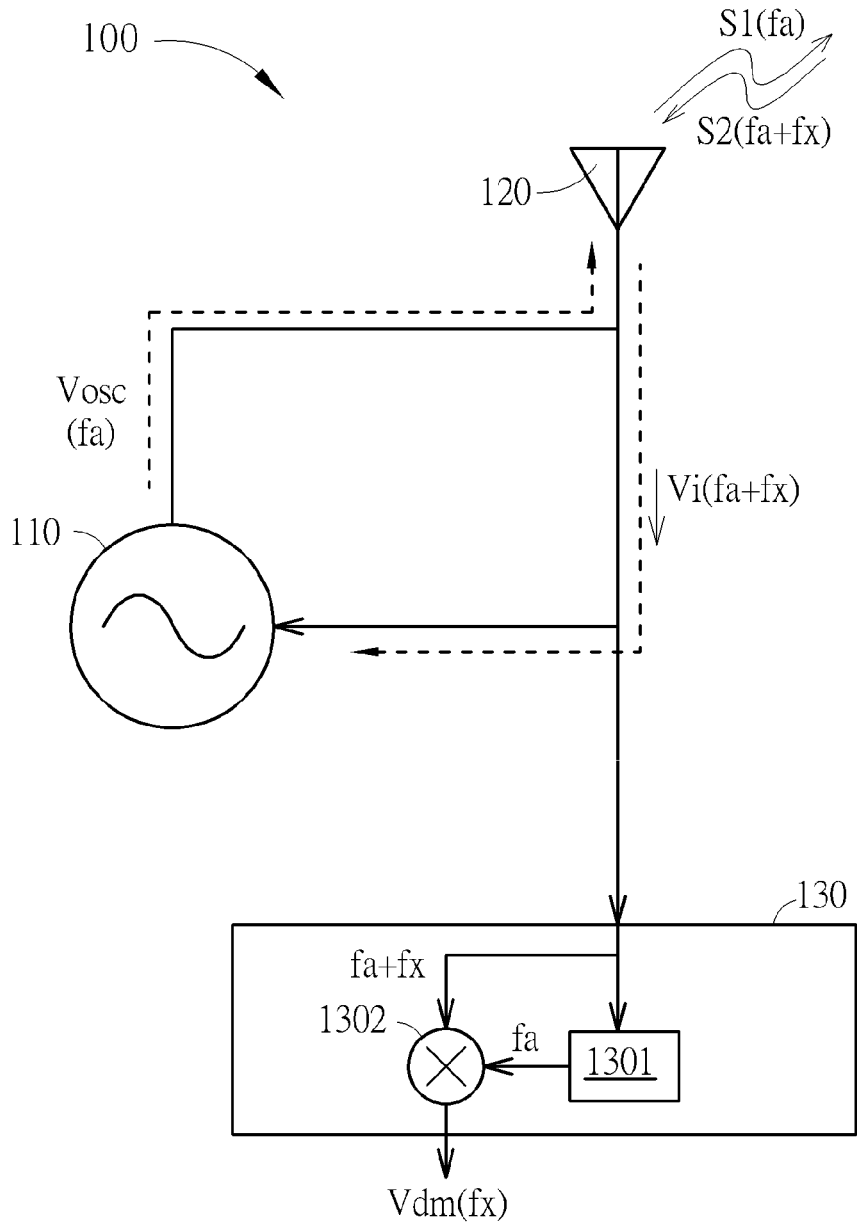

FIG. 1

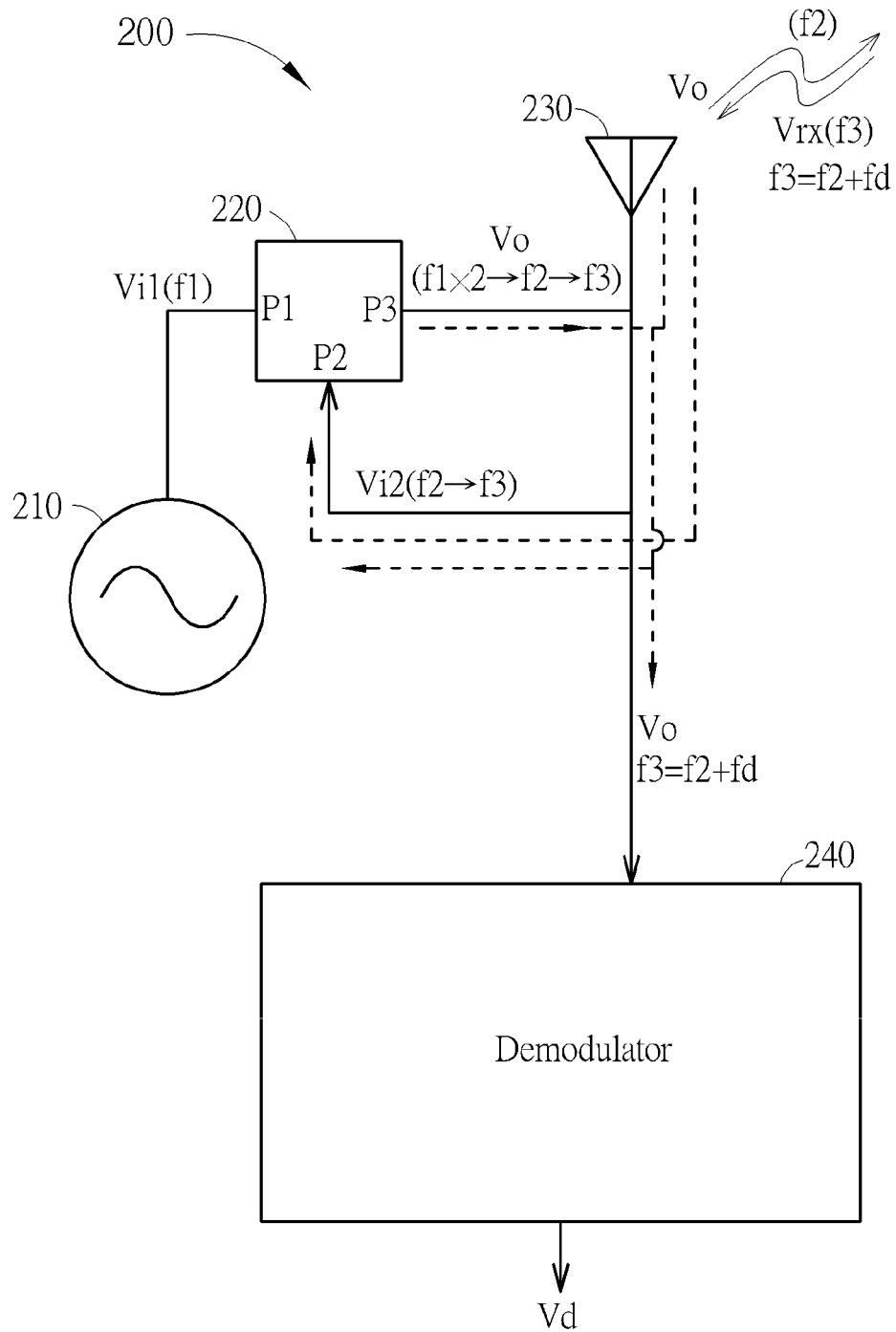

FIG. 2







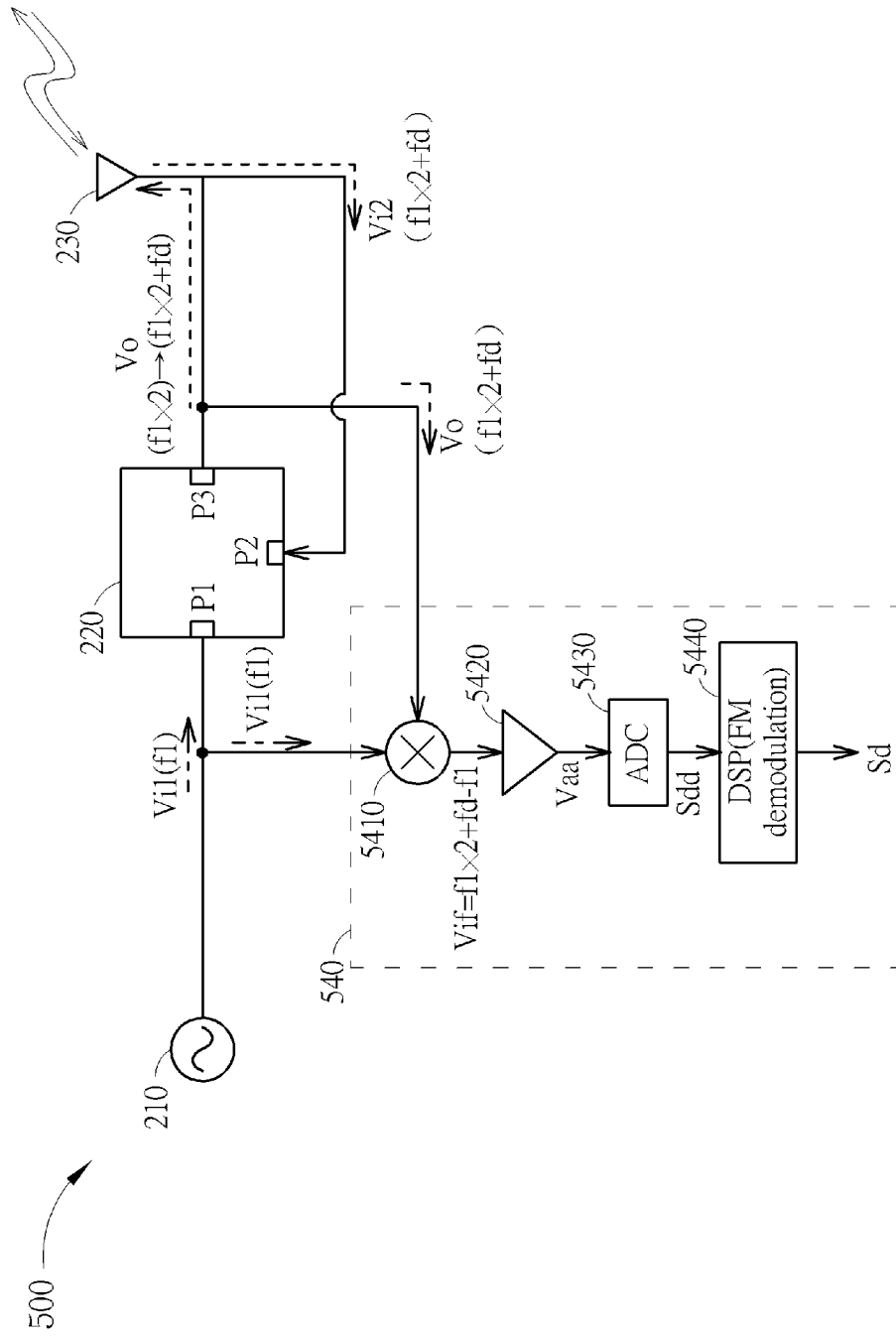

FIG. 6

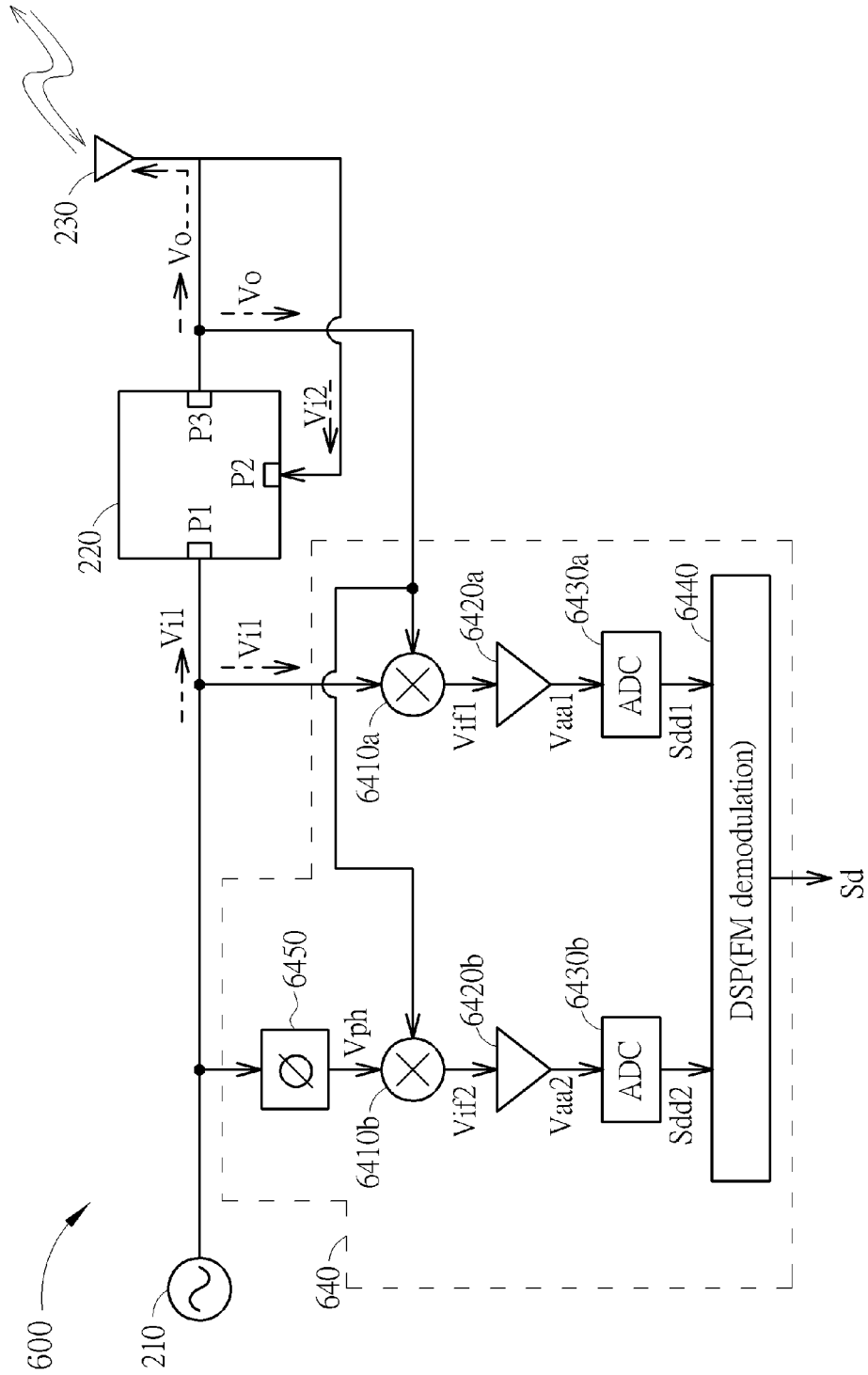

FIG. 7



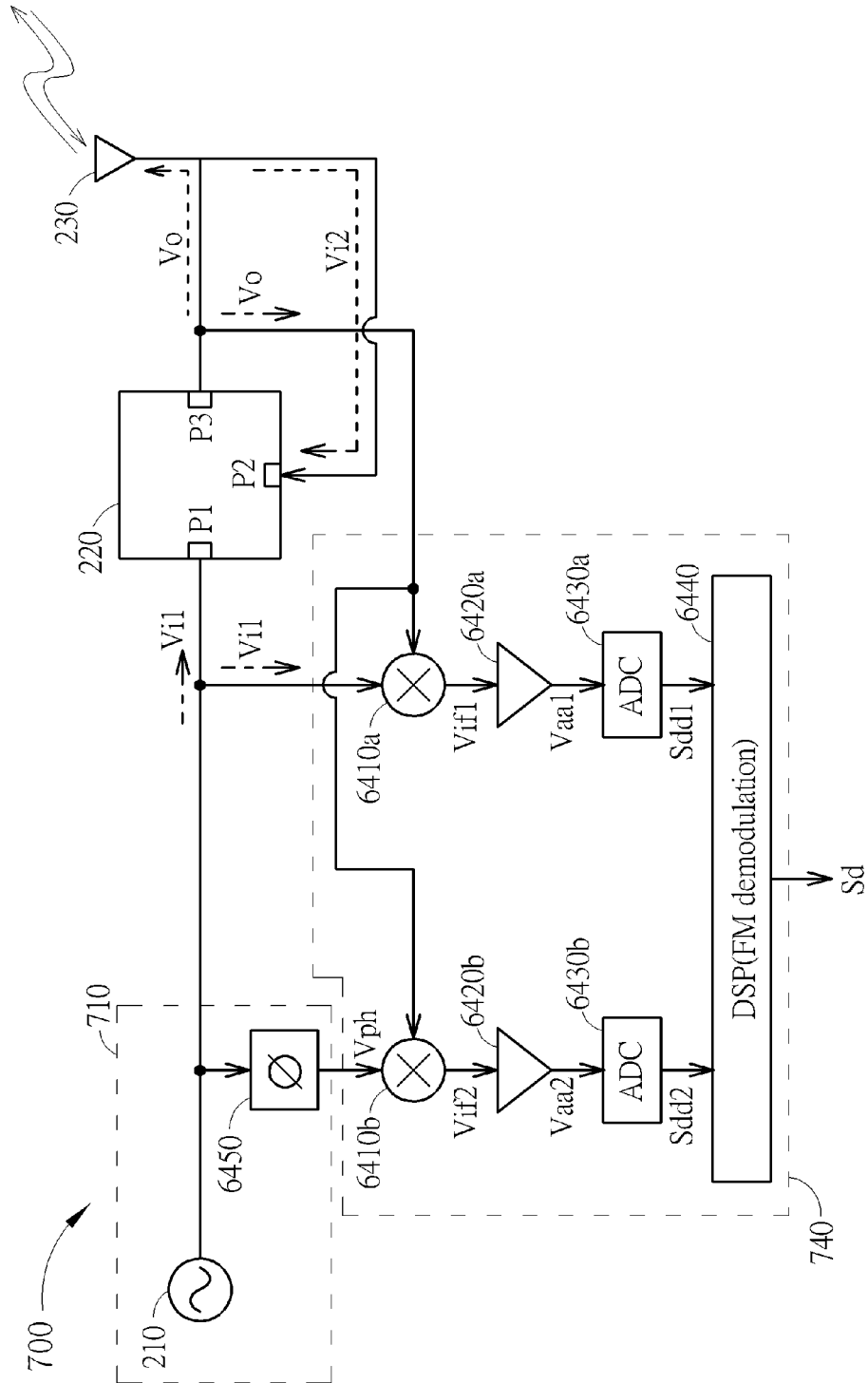

FIG. 8

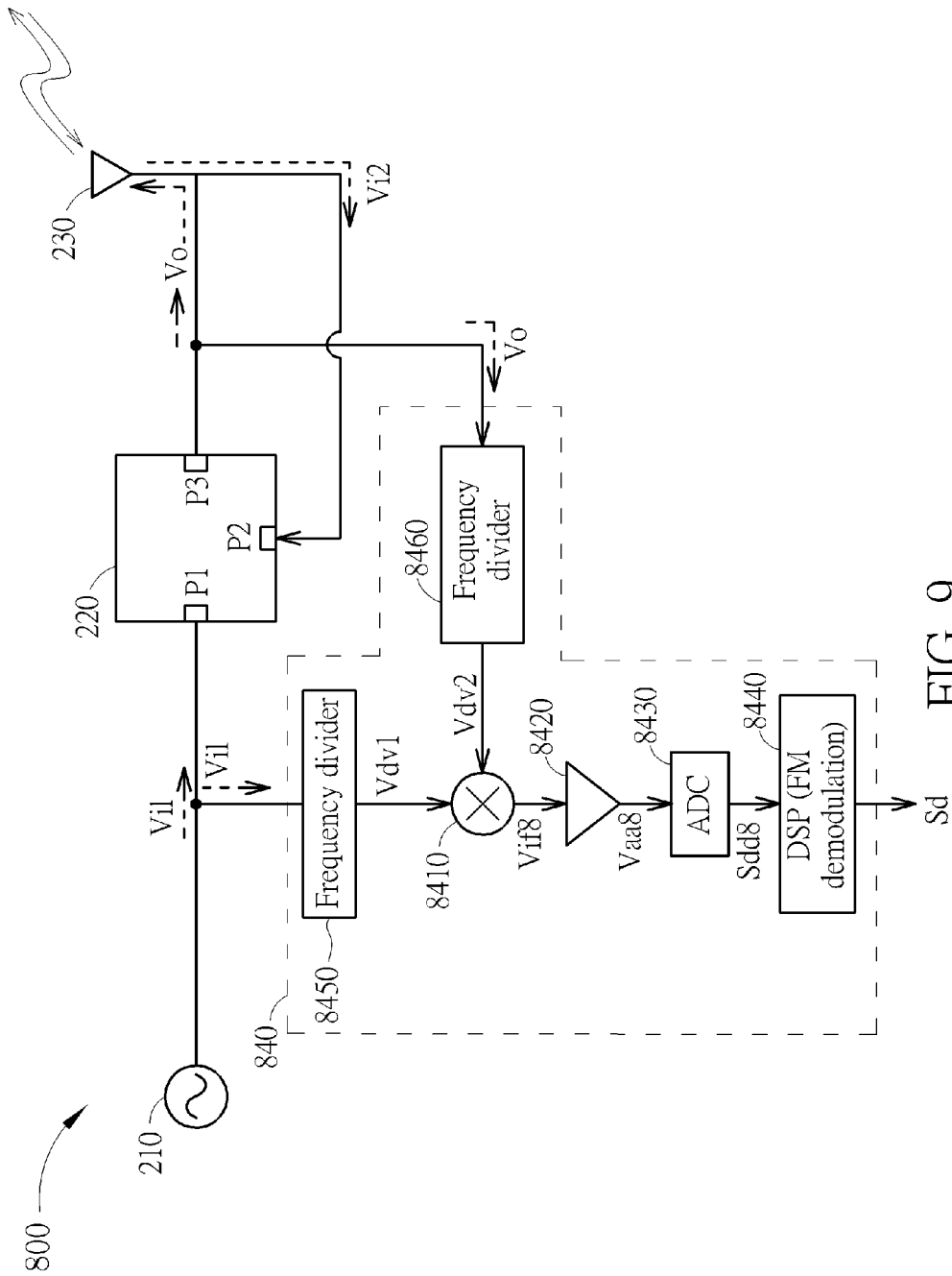

FIG. 9

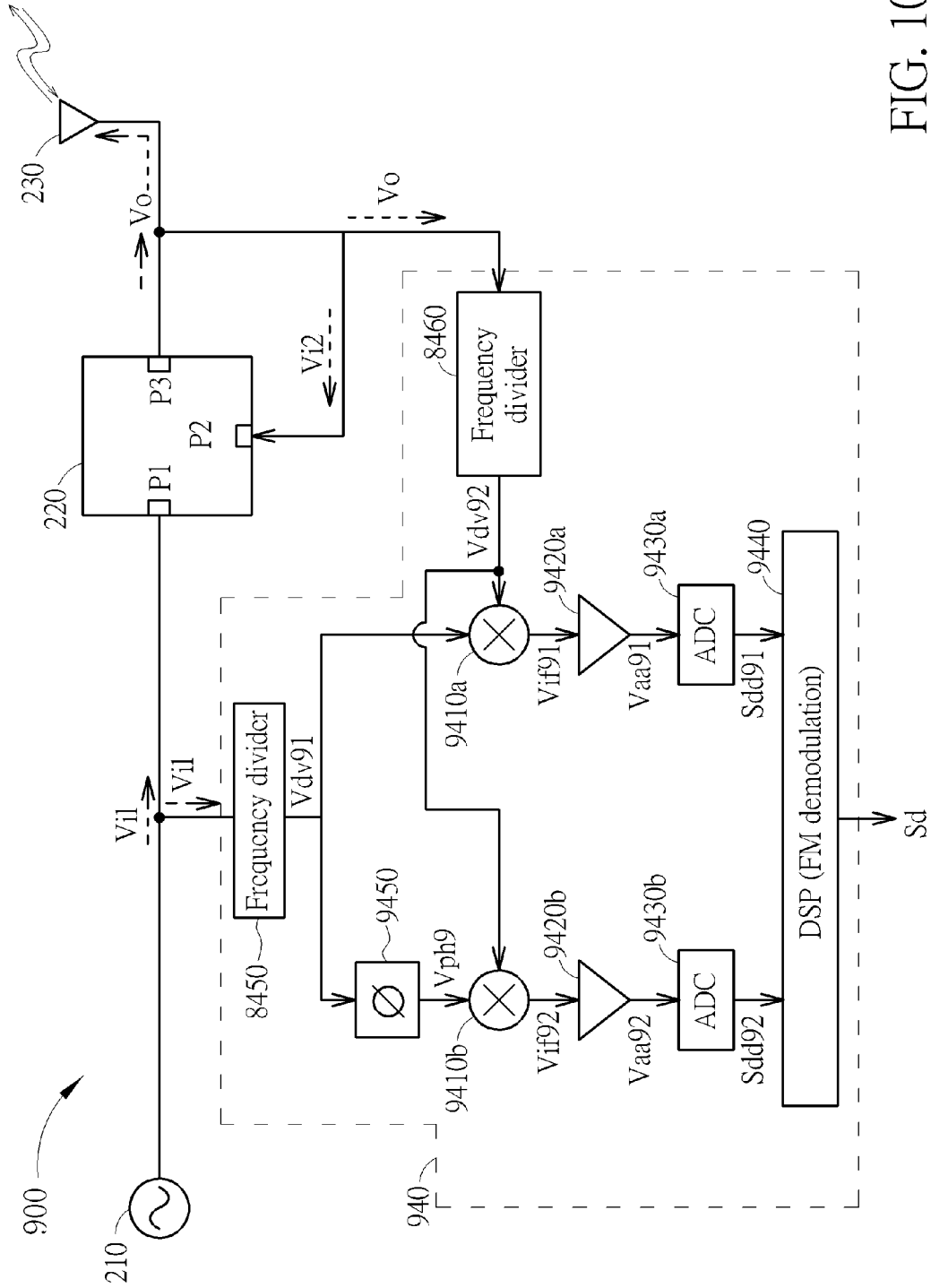

FIG. 10

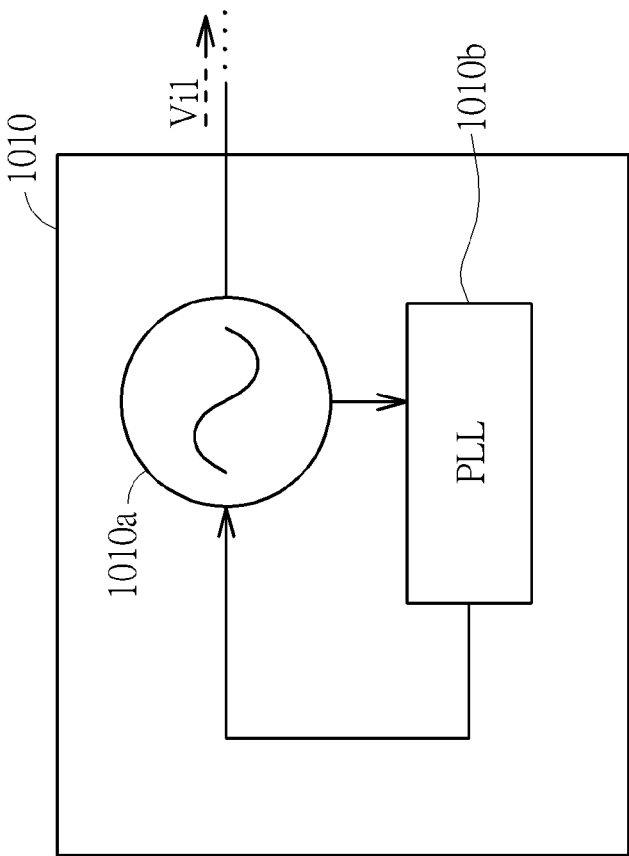

FIG. 11

**DETECTOR GENERATING A  
DISPLACEMENT SIGNAL BY INJECTION  
LOCKING AND INJECTION PULLING**

CROSS REFERENCE TO RELATED  
APPLICATION

[0001] This application claims priority to Taiwan Patent Application No. 104111323, filed Apr. 8, 2015, and incorporated herein by reference in its entirety.

TECHNICAL FIELD

[0002] The present invention relates to a detector, and more particularly, a detector including a frequency multiplier generating an output signal by injection pulling.

BACKGROUND

[0003] In general, a detector detecting the status of displacement of an object by the Doppler effect requires a high frequency input signal from an oscillation source operated at a high frequency to update the status of displacement of the object. Since it is difficult to process a high frequency signal with a digital process, an analog process is usually used to process the signal. Therefore, the signal is affected by flicker noise easily, the signal noise ratio (SNR) is reduced seriously, and the difficulty of subsequent digital signal processing (DSP) is increased. Furthermore, since the oscillation source is operated at a high frequency (e.g. around 10 GHz) which cannot be decreased, the power consumption of the oscillation source cannot be decreased easily. A solution with lower power consumption and smaller effect by flicker noise is required in this field.

SUMMARY

[0004] An embodiment of the present invention discloses a detector including an oscillation source, a frequency multiplier, a transceiver and a demodulator. The oscillation source is used to generate a first injection signal having a first frequency. The frequency multiplier includes a first injection terminal, an output terminal and a second injection terminal. The first injection terminal is coupled to the oscillation source, and used to receive the first injection signal. The output terminal is used to output an output signal. The second injection terminal is used to receive a second injection signal having a second frequency. The frequency multiplier outputs the output signal at a frequency equal to a multiple of the first frequency by injection locking, and pulls the output signal to the second frequency by injection pulling. The transceiver is coupled to the output terminal and the second injection terminal of the frequency multiplier, and used to transmit the output signal, and receive a received signal having a third frequency. The received signal is used to update the second injection signal. The demodulator is coupled to the output terminal of the frequency multiplier, and used to perform a demodulation operation so as to generate a displacement signal according to the output signal.

[0005] Another embodiment of the present invention discloses a frequency multiplier includes a first injection terminal, an output terminal and a second injection terminal. The first injection terminal is used to receive a first injection signal having a first frequency. The output terminal is used to output an output signal. The second injection terminal is used to receive a second injection signal having a second

frequency. The frequency multiplier outputs the output signal at a frequency equal to a multiple of the first frequency by injection locking, and pulls the output signal to the second frequency by injection pulling.

BRIEF DESCRIPTION OF THE DRAWINGS

[0006] FIG. 1 illustrates a detector according to an embodiment of the present invention.

[0007] FIG. 2 illustrates a detector according to another embodiment of the present invention.

[0008] FIG. 3 illustrates the frequency multiplier in FIG. 2 according to an embodiment of the present invention.

[0009] FIG. 4 illustrates that the frequency multiplier of FIG. 3 is coupled to the oscillation source and transceiver according to an embodiment of the present invention.

[0010] FIG. 5 illustrates the frequency multiplier in FIG. 2 according to another embodiment of the present invention.

[0011] FIG. 6 illustrates a detector according to another embodiment of the present invention.

[0012] FIG. 7 illustrates a detector according to another embodiment of the present invention.

[0013] FIG. 8 illustrates a detector according to another embodiment of the present invention.

[0014] FIG. 9 illustrates a detector according to another embodiment of the present invention.

[0015] FIG. 10 illustrates a detector according to another embodiment of the present invention.

[0016] FIG. 11 illustrates an oscillation source in FIG. 2 according to an embodiment of the present invention.

DETAILED DESCRIPTION

[0017] Below, exemplary embodiments will be described in detail with reference to accompanying drawings so as to be easily realized by a person having ordinary knowledge in the art. The inventive concept may be embodied in various forms without being limited to the exemplary embodiments set forth herein. Descriptions of well-known parts are omitted for clarity, and like reference numerals refer to like elements throughout.

[0018] FIG. 1 illustrates a detector **100** according to an embodiment of the present invention. The detector **100** includes an oscillation source **110**, an antenna **120** and a demodulator **130**. The demodulator **130** includes a delay **1301** and a frequency mixer **1302**. The oscillation source **110** generates an output signal  $V_{osc}$  with a frequency  $f_a$  at beginning so that the antenna **120** may transmit a detection signal **S1** with the frequency  $f_a$  outward. When the detection signal **S1** detects a detected object, a reflection signal **S2** is reflected back and received by the antenna **120**, and an input signal  $V_i$  is generated accordingly and sent to the oscillation source **110** and the demodulator **130**. The reflection signal **S2** has a frequency  $(f_a + f_x)$ , so the difference between the frequency  $(f_a + f_x)$  of the reflection signal **S2** and the frequency  $f_a$  of the detection signal **S1** is a frequency  $f_x$ . The input signal  $V_i$  has the frequency  $(f_a + f_x)$  according to the reflection signal **S2**. The frequency  $f_x$  is determined by the Doppler effect. The frequency  $f_x$  is a positive value when the detected object moves toward the detector **100**, and the frequency  $f_x$  is a negative value when the detected object moves away from the detector **100**. The frequency  $f_x$  may be updated according to the status of displacement of the detected object. When the input signal  $V_i$  is input into the demodulator **130**, an analog process is used since the fre-

quency ( $f_a+f_x$ ) of the input signal  $V_i$  is high (e.g. 10 GHz $\pm$ 150 Hz). The demodulator **130** may perform FM demodulation so as to generate a demodulated signal  $V_{dm}$ , and then obtain information of the displacement of the detected object according to the demodulated signal  $V_{dm}$ . The delay **1301** and the frequency mixer **1302** are used to obtain the frequency  $f_x$  bringing information of displacement of the detected object. The demodulated signal  $V_{dm}$  may be a voltage signal and processed in voltage domain. Since the demodulated signal  $V_{dm}$  is approximately a signal of with zero frequency, it is easily affected by flicker noise so as to decrease SNR and increase the difficulty of subsequent digital process.

[0019] FIG. 2 illustrates a detector **200** according to another embodiment of the present invention. The detector **200** includes an oscillation source **210**, a frequency multiplier **220**, a transceiver **230** and a demodulator **240**. The oscillation source is used to generate an injection signal  $V_{i1}$  having a frequency  $f_1$ . The frequency multiplier **220** includes injection terminals P1 and P2, and an output terminal P3. The injection terminal P1 is coupled to the oscillation source **210**, and used to receive the injection signal  $V_{i1}$ . The output terminal P3 is used to output an output signal  $V_o$ . The injection terminal P2 is used to receive an injection signal  $V_{i2}$  having a frequency  $f_2$ . The frequency multiplier **220** may output the output signal  $V_o$  at a frequency equal to a multiple of the frequency  $f_1$  (e.g.  $2/f_1$ ,  $3/f_1$ , etc.) by injection locking, and pulls the output signal  $V_o$  to the frequency  $f_2$  by injection pulling. The frequency multiplier **220** may be a double, triple or n-times frequency multiplier, where n is a positive integer. The transceiver **230** is coupled to the output terminal P3 and the injection terminal P2 of the frequency multiplier **220**, and used to transmit the output signal  $V_o$ , and receive a received signal  $V_{rx}$  having a frequency  $f_3$ . The received signal  $V_{rx}$  is used to update the injection signal  $V_{i2}$ . The demodulator **240** is coupled to the output terminal P3 of the frequency multiplier **220**, and used to perform a demodulation operation so as to generate a displacement signal  $V_d$  according to the output signal  $V_o$ . The displacement signal  $V_d$  may be an analog signal or a digital signal.

[0020] For example, if the injection signal  $V_{i2}$  has the frequency  $f_2$  (e.g. (10G+300) Hz), the frequency of the output signal  $V_o$  may be pulled from the double of the frequency  $f_1$  (e.g. 5G Hz), that is ( $f_1 \times 2$ ) (e.g. 10 GHz), to the frequency  $f_2$  (e.g. to (10G+300) Hz from 10G Hz) by injection pulling. The transceiver **230** (e.g. an antenna) may transmit the output signal  $V_o$  having the frequency  $f_2$  (e.g. (10G+300) Hz) outward. When detecting a detected object (e.g. a vehicle), the received signal  $V_{rx}$  may be reflected to the transceiver **230**. The received signal  $V_{rx}$  may have the frequency  $f_3$ . The relation of the frequency  $f_3$  of the received signal  $V_{rx}$  and the frequency  $f_2$  of the output signal  $V_o$  may be described by following equation  $\alpha$ :

$$f_3 = f_2 + f_d \quad (\alpha);$$

[0021] The frequency  $f_d$  may be a difference frequency generated by the Doppler effect. The difference frequency  $f_d$  may be positive if the detected object is moving forward the detector **200**, and the difference frequency  $f_d$  may be negative if the detected object is moving away from the detector **200**. After the transceiver **230** receives the received signal  $V_{rx}$  having the frequency  $f_3$  (i.e. ( $f_2+f_d$ )), for example, if  $f_d$  is 100 Hz, and  $f_2$  is (10G+300) Hz,  $f_3$  may be (10G+300+

100) Hz, that is (10G+400) Hz), the received signal  $V_{rx}$  (e.g. with a frequency of (10G+400) Hz) may be used to update the injection signal  $V_{i2}$ . Hence, the frequency of the injection signal  $V_{i2}$  may be updated from the frequency  $f_2$  (e.g. (10G+300) Hz) to the frequency  $f_3$  (e.g. (10G+400) Hz). After the injection signal  $V_{i2}$  is updated to the frequency  $f_3$  (e.g. (10G+400) Hz), the output signal  $V_o$  may be pulled to the frequency  $f_3$  (e.g. (10G+400) Hz) at the frequency multiplier **220** by injection pulling. The demodulator **240** may perform demodulation operation according to the frequency  $f_3$  (i.e.  $f_2+f_d$ ) to generate the displacement signal  $V_d$  corresponding to the difference between the frequencies  $f_2$  and  $f_3$ , that is the frequency  $f_d$ . The status of the displacement of the detected object may be determined according to the displacement signal  $V_d$ . Comparing with the oscillation source **110** operated at a high frequency (e.g. 10G Hz) in the previous embodiment, the operation frequency of the oscillation source **210** of the embodiment illustrated by FIG. 2 may be decreased to 50% or even lower according to the multiplier of the frequency multiplier **220**, and power consumption may be effectively reduced. Furthermore, since the demodulation operation of the embodiment of the present invention is performed at an intermediate frequency instead of a zero frequency, the harmful effect of flicker noise can be better prevented as described below.

[0022] FIG. 3 illustrates the frequency multiplier **220** according to an embodiment of the present invention. The frequency multiplier **220** includes a resonant circuit RC1 and transistors T1, T2, T3 and T4. The resonant circuit RC1 may be a tank circuit operated at a multiple (e.g. double) of the frequency  $f_1$ , and includes at least a capacitor C1, at least an inductor L1, a first terminal P311, and a second terminal P312 coupled the output terminal P3 of the frequency multiplier **220**. The inductor L1 may be coupled to a voltage source  $V_{DD}$  according to an embodiment. The transistor T1 includes a gate terminal coupled to the injection terminal P1 and used to receive a first phase portion  $V_{i11}$  of the injection signal  $V_{i1}$ , a first terminal coupled to the first terminal P311 of the resonant circuit RC1, and a second terminal coupled to a bias current source  $I_{bias}$ . The transistor T2 includes a gate terminal coupled to the injection terminal P1 and used to receive a second phase portion  $V_{i12}$  of the injection signal  $V_{i1}$ , a first terminal coupled to the first terminal P311 of the resonant circuit RC1, and a second terminal coupled to the bias current source  $I_{bias}$ . The transistor T3 includes a gate terminal coupled to the first terminal P311 of the resonant circuit RC1, a first terminal coupled to the second terminal P312 of the resonant circuit RC1, and a second terminal coupled to the bias current source  $I_{bias}$ . The transistor T4 includes a gate terminal coupled to the injection terminal P2 and used to receive the injection signal  $V_{i2}$ , a first terminal coupled to the second terminal P312 of the resonant circuit RC1, and a second terminal coupled to a current source  $I_x$ . According to an embodiment of the present invention, the current source  $I_x$  and the bias current source  $I_{bias}$  may be of an identical current source. FIG. 3 may be one of the designs of the frequency multiplier **220** rather than being used to limit the internal structure of the frequency multiplier **220**, and a designer may adjust the internal circuit of the frequency multiplier **220** according to requirement of the product.

[0023] FIG. 4 illustrates that the frequency multiplier **220** of FIG. is coupled to the oscillation source **210** and transceiver **230** according to an embodiment of the present

invention. According to FIG. 4, since the injection signal Vi1 is formed by the first phase portion Vi11 and second phase portion Vi12, the signals Vi11 and Vi12 may be input to the transistors T1 and T2 respectively. According to another embodiment, if the injection signal Vi1 is a single signal, an inverter may be coupled to the gate terminal of the transistor T2 so as to obtain a signal with a reversed phase of the injection signal Vi1. According to embodiment shown in FIG. 4, a coupling unit CP1 may be disposed between the transceiver 230 and the output terminal P3 of the frequency multiplier 220, and another coupling unit CP2 may be disposed between and the transceiver 230 and the injection terminal P2 of the frequency multiplier 220. The coupling unit CP1/CP2 may include a power amplifier, a low noise amplifier and/or a capacitor. A designer may determine whether to dispose the coupling unit CP1 and/or the coupling unit CP2, and determine the sort of the coupling unit CP1/CP2 according to design requirement or result of measurement so as to improve the effect of detection. For example, a smaller capacitor may be chosen for signals of higher frequency.

[0024] FIG. 5 illustrates the frequency multiplier 220 according to another embodiment of the present invention. The frequency multiplier 220 may include a resonant circuit RC2, transistors T11-T18, resistors R2-R3 and capacitors C11-C12. The resonant circuit RC2 may be operated at a multiple of the frequency f1, and includes a resistor R1, an inductor L2, a voltage terminal P513 coupled to a voltage source V<sub>DD</sub>, a first terminal P511 and a second terminal P512. The voltage terminal P513 may couple to the middle of the inductor L2 through the resistor R1. The transistor T11 may include a gate terminal coupled to the second terminal P512 of the resonant circuit RC2, a first terminal coupled to the voltage source V<sub>DD</sub>, and a second terminal coupled to the output terminal P3 of the frequency multiplier 220. The transistor T12 may include a gate terminal coupled to the first terminal P511 of the resonant circuit RC2, a first terminal coupled to a ground terminal, and a second terminal coupled to the ground terminal. The transistor T13 may include a gate terminal coupled to the first terminal P511 of the resonant circuit RC2, a first terminal coupled to the second terminal P512 of the resonant circuit RC2, and a second terminal. The transistor T14 may include a gate terminal coupled to the second terminal P512 of the resonant circuit RC2, a first terminal coupled to the first terminal P511 of the resonant circuit RC2, and a second terminal. The transistor T15 may include a gate terminal, a first terminal coupled to the second terminal of the transistor T13, and a second terminal coupled to the ground terminal. The transistor T16 may include a gate terminal, a first terminal coupled to the second terminal of the transistor T14, and a second terminal coupled to the second terminal of the transistor T15 and the ground terminal. The resistor R2 may include a first terminal coupled to the gate terminal of the transistor T16, and a second terminal coupled to a bias voltage source V<sub>bias</sub>. The resistor R3 may include a first terminal coupled to the bias voltage source V<sub>bias</sub>, and a second terminal coupled to the gate terminal of the transistor T15. The capacitor C11 may include a first terminal coupled to the injection terminal P1 and used to receive the first phase portion Vi11 of the injection signal Vi1, and a second terminal coupled to the first terminal of the resistor R1. The capacitor C12 may include a first terminal coupled to the injection terminal P1 and used to receive the second phase

portion Vi12 of the injection signal Vi1, and a second terminal coupled to the gate terminal of the transistor T15. The transistor T17 may include a first terminal coupled to the gate terminal of the transistor T12, a gate terminal coupled to the injection terminal P2 and used to receive the injection signal Vi2, and a second terminal coupled to a current source Iz. The transistor T18 includes a first terminal coupled to the gate terminal of the transistor T11, a gate terminal coupled to the second injection terminal P2 and configured to receive the second injection signal Vi2, and a second terminal coupled to the current source Iz. The current source Iz may be coupled to the ground terminal. According to an embodiment of the present invention, the gate terminal of the transistor T17 may be used to receive a first phase portion Vi21 of the injection signal Vi2, and the gate terminal of the transistor T18 may be used to receive a second phase portion Vi22 of the injection signal Vi2.

[0025] FIG. 6 illustrates a detector 500 according to another embodiment of the present invention. The detector 500 may include the oscillation source 210, the frequency multiplier 220, the transceiver 230 and a demodulator 540. The demodulator 540 may include a frequency mixer 5410, an amplifier 5420, an analog-to-digital converter (ADC) 5430 and a digital signal processor (DSP) 5440. The frequency mixer 5410 may include a mixer, be coupled to the injection terminal P1 and the output terminal P3 of the frequency multiplier 220, and be used to mix frequencies of the injection signal Vi1 and the output signal Vo to generate an intermediate frequency (IF) signal Vif. The amplifier 5420 may include a voltage amplifier and/or a current amplifier, be coupled to the frequency mixer 5410, and used to amplify the intermediate frequency signal Vif so as to generate an analog signal Vaa. The analog-to-digital converter 5430 may be coupled to the amplifier 5420 and used to convert the analog signal Vaa to a digital signal Sdd. The digital signal processor 5440 may be coupled to the analog-to-digital converter 5430 and used to demodulate the digital signal Sdd so as to generate the displacement signal Sd. The digital signal processor 5440 may perform FM (frequency modulation) demodulation. The displacement signal Sd may correspond to the status of displacement of the detected object, and the displacement signal Sd may be a digital signal.

[0026] For example, if the frequency multiplier 220 of FIG. 6 is a double multiplier, the injection signal Vi1 has the frequency f1 (e.g. 5G Hz), and the output signal Vo is pulled by injection pulling so as to have a frequency as (f1×2+fd), that is twice the frequency f1 plus the difference frequency fd generated by the Doppler effect, the frequency of the intermediate frequency signal Vif outputted by the frequency mixer 5410 may be shown as the equation β:

The frequency of the intermediate frequency signal Vif = (β)

The frequency of the output signal Vo =

The frequency of the injection signal Vi1 =

$$(f1 \times 2 + fd) - f1 = f1 + fd \dots$$

[0027] The frequency f1 as 5G Hz, and the difference frequency fd generated by the Doppler effect triggered by the movement of the detected object as 150 Hz may be taken for example. Regarding the input signal Vi processed by the

demodulator **130** in FIG. **1**, the frequency of the input signal  $V_i$  may be  $(fa+fx)$ , that is  $(10G+150)$  Hz for example, hence it is known that the frequency of the intermediate frequency signal  $V_{if}$  (e.g.  $(5G+150)$  Hz) may be of an intermediate frequency and with much lower frequency than the input signal  $V_i$  processed by the demodulator **130** shown in FIG. **1**. Hence, in the embodiment of FIG. **6**, the intermediate frequency signal  $V_{if}$  may be processed by using a digital process, and is allowed to be amplified, converted from analog to digital and processed with DSP without being FM demodulated first. Hence, the amplifier **5420** generating the analog signal  $V_{aa}$ , and the analog-to-digital converter **5430** generating the digital signal  $S_{dd}$  may be performed in frequency domain. Since none of the analog signal  $V_{aa}$  and the digital signal  $S_{dd}$  is an approximate zero frequency signal, the demodulator **540** is difficult to be affected by flicker noise. When the digital signal processor **5440** generates the displacement signal  $S_d$ , the FM demodulation is performed. Comparing FIG. **6** with FIG. **1**, it is known that the frequency of the processed signal may be reduced at the front-end (e.g. the frequency mixer **5410**) in the embodiment of FIG. **6** so that the intermediate frequency signal may be processed by a digital process, and the reduction of SNR caused by flicker noise may be prevented.

[0028] FIG. **7** illustrates a detector **600** according to another embodiment of the present invention. A demodulator **640** of the detector **600** may include frequency mixers **6410a** and **6410b**, amplifiers **6420a** and **6420b**, analog-to-digital converters **6430a** and **6430b**, a phase adjustment unit **6450** and a digital signal processor **6440**. The frequency mixer **6410a** may be coupled to the injection terminal P1 and the output terminal P3 of the frequency multiplier **220**, and be used to mix frequencies of the injection signal  $V_{i1}$  and the output signal  $V_o$  to generate an intermediate frequency signal  $V_{if1}$ . The amplifier **6420a** may be coupled to the frequency mixer **6410a** and be used to amplify the intermediate frequency signal  $V_{if1}$  to generate an analog signal  $V_{aa1}$ . The analog-to-digital converter **6430a** may be coupled to the amplifier **6420a** and be used to convert the analog signal  $V_{aa1}$  to a digital signal  $S_{dd1}$ . The phase adjustment unit **6450** may be coupled to the oscillation source **210** and be used to receive the injection signal  $V_{i1}$  and adjust a phase of the injection signal  $V_{i1}$  (e.g. by shifting 90 degrees) so as to generate a phase shift signal  $V_{ph}$ . The frequency mixer **6410b** may be coupled to the phase adjustment unit **6450** and the output terminal P3 of the frequency multiplier **220**, and be used to mix frequencies of the phase shift signal  $V_{ph}$  and the output signal  $V_o$  to generate an intermediate frequency signal  $V_{if2}$ . The amplifier **6420b** may be coupled to the frequency mixer **6410b** and be used to amplify the intermediate frequency signal  $V_{if2}$  to generate an analog signal  $V_{aa2}$ . The analog-to-digital converter **6430b** may be coupled to the amplifier **6420b** and be used to convert the analog signal  $V_{aa2}$  to a digital signal  $S_{dd2}$ . The digital signal processor **6440** may be coupled to the analog-to-digital converters **6430a** and **6430b**, and be used to demodulate the digital signals  $S_{dd1}$  and  $S_{dd2}$  so as to generate the displacement signal  $S_d$ . In FIG. **7**, the demodulator **640** with a dual-path structure may support dual-path signals such as I-Q signals. For example, the frequency mixer **6410a**, the amplifier **6420a** and the analog-to-digital converter **6430a** may be used to process the I-signal, and the frequency mixer **6410b**, the amplifier **6420b** and the analog-to-digital converter **6430b** may be used to process the Q-signal. Since the

I-signal is different from the Q-signal (e.g. the I-Q signals being of a sine waveform and a cosine waveform respectively), blind zones led by standing waves may be avoided. The structure shown in FIG. **7** with the dual-path structure may support I-Q signals to improve a demodulation performance.

[0029] FIG. **8** illustrates a detector **700** according to another embodiment of the present invention. The detector **700** may include an oscillation source **710**, a frequency multiplier **220**, a transceiver **230** and a demodulator **740**. The demodulator **740** may include the frequency mixers **6410a** and **6410b**, the amplifiers **6420a** and **6420b**, the analog-to-digital converters **6430a** and **6430b**, and the digital signal processor **6440**. Different from the demodulator **640** of FIG. **7**, the demodulator **740** may not include the phase adjustment unit **6450**. The oscillation source **710** may output the injection signal  $V_{i1}$  having the frequency  $f_1$  and the phase shift signal  $V_{ph}$  generated by adjusting the phase of the injection signal  $V_{i1}$  (e.g. shifting the phase of the injection signal  $V_{i1}$  by 90 degrees). The operations of the frequency mixers **6410a** and **6410b**, the amplifiers **6420a** and **6420b**, the analog-to-digital converters **6430a** and **6430b**, and the digital signal processor **6440** may be as described in FIG. **7**, and are not repeated herein. The oscillation source **710** providing two signals with different phases may be required in the detector **700**, and dual-path signals such as I-Q signals may be supported to improve a demodulation performance.

[0030] FIG. **9** illustrates a detector **800** according to an embodiment of the present invention. The detector **800** may include the oscillation source **210**, the frequency multiplier **220**, the transceiver **230** and a demodulator **840**. The operations of the oscillation source **210**, the frequency multiplier **220** and the transceiver **230** may be as described above, and are not repeated herein. The demodulator **840** includes frequency dividers **8450** and **8460**, a frequency mixer **8410**, an amplifier **8420**, an analog-to-digital converter **8430** and a digital signal processor **8440**. The frequency divider **8450** may be coupled to the oscillation source **210** and be used to divide frequency of the injection signal  $V_{i1}$  so as to generate a frequency-divided signal  $V_{dv1}$ . The frequency divider **8460** may be coupled to the output terminal P3 of the frequency multiplier **220**, and be used to divide frequency of the output signal  $V_o$  so as to generate a frequency-divided signal  $V_{dv2}$ . The frequency mixer **8410** may be coupled to the frequency dividers **8450** and **8460**, and be used to mix frequencies of the frequency-divided signals  $V_{dv1}$  and  $V_{dv2}$  so as to generate an intermediate frequency signal  $V_{if8}$ . The amplifier **8420** may be coupled to the frequency mixer **8410** and be used to amplify the intermediate frequency signal  $V_{if8}$  so as to generate an analog signal  $V_{aa8}$ . The analog-to-digital converter **8430** may be coupled to the amplifier **8420** and be used to convert the analog signal  $V_{aa8}$  to a digital signal  $S_{dd8}$ . The digital signal processor **8440** may be coupled to the analog-to-digital converter **8430** and be used to demodulate the digital signal  $S_{dd8}$  so as to generate the displacement signal  $S_d$ .

[0031] The frequency divider **8450** may perform frequency division with a divisor X, and the frequency divider **8460** may perform frequency division with a divisor Y. Suppose the frequency of the injection signal  $V_{i1}$  is 5G Hz, the frequency of the output signal  $V_o$  is 10G Hz, the divisor



X is 4 and the divisor Y is 9, the frequency of the intermediate frequency signal Vif8 may be described as the equation 7:

$$\begin{aligned} \text{The frequency of the intermediate frequency signal Vif8} = & \quad (7) \\ & ((\text{frequency of the output signal } V_o) \div Y - \\ & (\text{frequency of the injection signal } V_i) \div X) = \\ & |10G \text{ Hz} \div 9 - 5G \text{ Hz} \div 4| = 139 \text{ M Hz} \dots \dots \end{aligned}$$

[0032] Hence, the frequency of the intermediate frequency Vif8 may be reduced to be relatively low so as to be easily processed by a digital signal process. The intermediate frequency Vif8 may be processed by the amplifier 8420 and the analog-to-digital converter 8430, and then be FM demodulated when being processed by the digital signal processor 8440. Since the intermediate frequency Vif8 may not be processed approximately at a zero frequency, the detector 800 may not be affected by flicker noise easily.

[0033] FIG. 10 illustrates a detector 900 according to another embodiment of the present invention. The detector 900 may include the oscillation source 210, the frequency multiplier 220, the transceiver 230 and a demodulator 940. The operations of the oscillation source 210, the frequency multiplier 220 and the transceiver 230 may be as described above, so are not repeated herein. The demodulator 940 may include the frequency dividers 8450 and 8460, frequency mixers 9410a and 9410b, amplifiers 9420a and 9420b, analog-to-digital converters 9430a and 9430b, a phase adjustment unit 9450, and a digital signal processor 9440. The frequency divider 8450 may be coupled to the oscillation source 210 and used to divide frequency of the injection signal Vi1 so as to generate a frequency-divided signal Vdv91. The frequency divider 8460 may be coupled to the output terminal P3 of the frequency multiplier 220 and used to divide frequency of the output signal Vo so as to generate a frequency-divided signal Vdv92. The frequency mixer 9410a may be coupled to the frequency dividers 8450 and 8460, and used to mix frequencies of the frequency-divided signals Vdv91 and Vdv92 so as to generate an intermediate frequency signal Vif91. The amplifier 9420a may be coupled to the frequency mixer 9410a and used to amplify the intermediate frequency signal Vif91 so as to generate an analog signal Vaa91. The analog-to-digital converter 9430a may be coupled to the amplifier 9420a and used to convert the analog signal Vaa91 to a digital signal Sdd91. The phase adjustment unit 9450 may be coupled to the frequency divider 8450 and used to receive the frequency-divided signal Vdv91 and adjust a phase of the frequency-divided signal Vdv91 so as to generate a phase shift signal Vph9. The frequency mixer 9410b may be coupled to the phase adjustment unit 9450 and the frequency divider 8460, and used to mix frequencies of the phase shift signal Vph9 and the frequency-divided signal Vdv92 so as to generate an intermediate frequency signal Vif92. The amplifier 9420b may be coupled to the frequency mixer 9410b and used to amplify the intermediate frequency signal Vif92 so as to generate an analog signal Vaa92. The analog-to-digital converter 9430b may be coupled to the amplifier 9420b and used to convert the analog signal Vaa92 to a digital signal Sdd92. The digital signal processor 9440 may be coupled to the analog-to-digital converters 9430a and 9430b, and used

to demodulate the digital signals Sdd91 and Sdd92 so as to generate the displacement signal Sd. Similar to the detector 800, since the detector 900 includes the frequency dividers 8450 and 8460, the intermediate frequency signals processed by the detector 900 such as the intermediate frequency signals Vif91 and Vif92 may be of relatively low frequency (e.g. 130 MHz), it is easier to be processed by a digital signal process. FM demodulation may be not performed before the signals are sent to the amplifiers and analog-to-digital converters, so the effect of flicker noise may be avoided. Similar to the detector 500, since the detector 900 has a dual-path structure, it may support dual-path signals such as I-Q signals for a better effect of the demodulation.

[0034] FIG. 11 illustrates an oscillation source 1010 according to an embodiment of the present invention. The oscillation sources of the detectors mentioned above may be replaced by the oscillation source 1010. The oscillation source 1010 may include an oscillator 1010a and a phase-locked loop 1010b. If the oscillator 1010a is analog type, the phase-locked loop 1010b may be analog type. If the oscillator 1010a is digital type, the phase-locked loop 1010b may be digital type. The phase-locked loop 1010b may increase the stability of the frequency of the output signal from the oscillation source 1010 without being affected by temperature or supplied voltage. The detector may therefore be more suitable for accurate applications and communication regulations.

[0035] In summary, the detectors disclosed by embodiments of the present invention may avoid the interference made by flicker noise so that the signal-to-noise ratio may not be reduced. Furthermore, the operation frequency of the oscillation sources used in the detectors disclosed by embodiments of the present invention may be decreased greatly, so the power consumption may be decreased. The shortcomings of low signal-to-noise ratio and high power consumption of the detectors of prior art may be effectively improved.

[0036] Those skilled in the art will readily observe that numerous modifications and alterations of the device and method may be made while retaining the teachings of the invention. Accordingly, the above disclosure should be construed as limited only by the metes and bounds of the appended claims.

What is claimed is:

1. A detector comprising:

an oscillation source configured to generate a first injection signal having a first frequency;

a frequency multiplier comprising:

a first injection terminal coupled to the oscillation source, and configured to receive the first injection signal;

an output terminal configured to output an output signal; and

a second injection terminal configured to receive a second injection signal having a second frequency; wherein the frequency multiplier outputs the output signal at a frequency equal to a multiple of the first frequency by injection locking, and pulls the output signal to the second frequency by injection pulling;

a transceiver coupled to the output terminal and the second injection terminal of the frequency multiplier, and configured to transmit the output signal, and receive a received signal having a third frequency,

- wherein the received signal is configured to update the second injection signal; and
- a demodulator coupled to the output terminal of the frequency multiplier, and configured to perform a demodulation operation so as to generate a displacement signal according to the output signal.
2. The detector of claim 1, wherein the frequency multiplier further comprises:
- a resonant circuit operated at a multiple of the first frequency, and comprising a capacitor, an inductor, a first terminal, and a second terminal coupled the output terminal of the frequency multiplier;
  - a first transistor comprising a gate terminal coupled to the first injection terminal and configured to receive a first phase portion of the first injection signal, a first terminal coupled to the first terminal of the resonant circuit, and a second terminal configured to couple to a bias current source;
  - a second transistor comprising a gate terminal coupled to the first injection terminal and configured to receive a second phase portion of the first injection signal, a first terminal coupled to the first terminal of the resonant circuit, and a second terminal configured to couple to the bias current source;
  - a third transistor comprising a gate terminal coupled to the first terminal of the first transistor, a first terminal coupled to the second terminal of the resonant circuit, and a second terminal coupled to the bias current source; and
  - a fourth transistor comprising a gate terminal coupled to the second injection terminal and configured to receive the second injection signal, a first terminal coupled to the second terminal of the resonant circuit, and a second terminal configured to couple to a current source.
3. The detector of claim 2, wherein the current source and the bias current source are of an identical current source.
4. The detector of claim 1, wherein the frequency multiplier further comprises:
- a resonant circuit operated at a multiple of the first frequency, and comprising a first resistor, an inductor, a voltage terminal configured to couple to a voltage source, a first terminal, and a second terminal;
  - a first transistor comprising a gate terminal coupled to the second terminal of the resonant circuit, a first terminal, and a second terminal coupled to the output terminal of the frequency multiplier;
  - a second transistor comprising a gate terminal coupled to the first terminal of the resonant circuit, a first terminal coupled to a ground terminal, and a second terminal configured to couple to the ground terminal;
  - a third transistor comprising a gate terminal coupled to the first terminal of the resonant circuit, a first terminal coupled to the second terminal of the resonant circuit, and a second terminal;
  - a fourth transistor comprising a gate terminal coupled to the second terminal of the resonant circuit, a first terminal coupled to the first terminal of the resonant circuit, and a second terminal;
  - a fifth transistor comprising a gate terminal, a first terminal coupled to the second terminal of the third transistor, and a second terminal configured to couple to the ground terminal;
  - a sixth transistor comprising a gate terminal, a first terminal coupled to the second terminal of the fourth transistor, and a second terminal coupled to the second terminal of the fifth transistor and configured to couple to the ground terminal;
  - a second resistor comprising a first terminal coupled to the gate terminal of the sixth transistor, and a second terminal configured to couple to a bias voltage source;
  - a third resistor comprising a first terminal configured to couple to the bias voltage source, and a second terminal coupled to the gate terminal of the fifth transistor;
  - a first capacitor comprising a first terminal coupled to the first injection terminal and configured to receive a first phase portion of the first injection signal, and a second terminal coupled to the first terminal of the second resistor;
  - a second capacitor comprising a first terminal coupled to the first injection terminal and configured to receive a second phase portion of the first injection signal, and a second terminal coupled to the gate terminal of the fifth transistor;
  - a seventh transistor comprising a first terminal coupled to the gate terminal of the second transistor, a gate terminal coupled to the second injection terminal and configured to receive the second injection signal, and a second terminal configured to couple to a current source; and
  - an eighth transistor comprising a first terminal coupled to the gate terminal of the first transistor, a gate terminal coupled to the second injection terminal and configured to receive the second injection signal, and a second terminal configured to couple to the current source.
5. The detector of claim 4, wherein the gate terminal of the seventh transistor is configured to receive a first phase portion of the second injection signal, and the gate terminal of the eighth transistor is configured to receive a second phase portion of the second injection signal.
6. The detector of claim 1, further comprising:
- a coupling unit disposed between the transceiver and the output terminal of the frequency multiplier, or between the second injection terminal and the transceiver; wherein the coupling unit comprises a power amplifier, a low noise amplifier and/or a capacitor.
7. The detector of claim 1, wherein the demodulator comprises:
- a frequency mixer coupled to the first injection terminal and the output terminal of the frequency multiplier, and configured to mix frequencies of the first injection signal and the output signal to generate an intermediate frequency signal;
  - an amplifier coupled to the frequency mixer and configured to amplify the intermediate frequency signal so as to generate an analog signal;
  - an analog-to-digital converter coupled to the amplifier and configured to convert the analog signal to a digital signal; and
  - a digital signal processor coupled to the analog-to-digital converter and configured to demodulate the digital signal so as to generate the displacement signal.
8. The detector of claim 1, wherein the demodulator comprises:
- a first frequency mixer coupled to the first injection terminal and the output terminal of the frequency multiplier, and configured to mix frequencies of the

first injection signal and the output signal to generate a first intermediate frequency signal;

- a first amplifier coupled to the first frequency mixer and configured to amplify the first intermediate frequency signal to generate a first analog signal;
- a first analog-to-digital converter coupled to the first amplifier and configured to convert the first analog signal to a first digital signal;
- a phase adjustment unit coupled to the oscillation source and configured to receive the first injection signal and adjust a phase of the first injection signal so as to generate a phase shift signal;
- a second frequency mixer coupled to the phase adjustment unit and the output terminal of the frequency multiplier, and configured to mix frequencies of the phase shift signal and the output signal to generate a second intermediate frequency signal;
- a second amplifier coupled to the second frequency mixer and configured to amplify the second intermediate frequency signal to generate a second analog signal;
- a second analog-to-digital converter coupled to the second amplifier and configured to convert the second analog signal to a second digital signal; and
- a digital signal processor coupled to the first analog-to-digital converter and the second analog-to-digital converter, and configured to demodulate the first digital signal and the second digital signal so as to generate the displacement signal.

9. The detector of claim 1, wherein the oscillation source is further configured to generate a phase shift signal generated by adjusting a phase of the first injection signal, and the demodulator comprises:

- a first frequency mixer coupled to the first injection terminal and the output terminal of the frequency multiplier, and configured to mix frequencies of the first injection signal and the output signal to generate a first intermediate frequency signal;
- a first amplifier coupled to the first frequency mixer and configured to amplify the first intermediate frequency signal so as to generate a first analog signal;
- a first analog-to-digital converter coupled to the first amplifier and configured to convert the first analog signal to a first digital signal;
- a second frequency mixer coupled to the oscillation source and the output terminal of the frequency multiplier, and configured to mix frequencies of the phase shift signal and the output signal so as to generate a second intermediate frequency signal;
- a second amplifier coupled to the second frequency mixer and configured to amplify the second intermediate frequency signal so as to generate a second analog signal;
- a second analog-to-digital converter coupled to the second amplifier and configured to convert the second analog signal to a second digital signal; and
- a digital signal processor coupled to the first analog-to-digital converter and the second analog-to-digital converter, and configured to demodulate the first digital signal and the second digital signal so as to generate the displacement signal.

10. The detector of claim 1, wherein the demodulator comprises:

- a first frequency divider coupled to the oscillation source and configured to divide frequency of the first injection signal so as to generate a first frequency-divided signal;
- a second frequency divider coupled to the output terminal of the frequency multiplier and configured to divide frequency of the output signal so as to generate a second frequency-divided signal;
- a frequency mixer coupled to the first frequency divider and the second frequency divider, and configured to mix frequencies of the first frequency-divided signal and the second frequency-divided signal so as to generate an intermediate frequency signal;
- an amplifier coupled to the frequency mixer and configured to amplify the intermediate frequency signal so as to generate an analog signal;
- an analog-to-digital converter coupled to the amplifier and configured to convert the analog signal to a digital signal; and
- a digital signal processor coupled to the analog-to-digital converter and configured to demodulate the digital signal so as to generate the displacement signal.

11. The detector of claim 1, wherein the demodulator comprises:

- a first frequency divider coupled to the oscillation source and configured to divide frequency of the first injection signal so as to generate a first frequency-divided signal;
- a second frequency divider coupled to the output terminal of the frequency multiplier and configured to divide frequency of the output signal so as to generate a second frequency-divided signal;
- a first frequency mixer coupled to the first frequency divider and the second frequency divider, and configured to mix frequencies of the first frequency-divided signal and the second frequency-divided signal so as to generate a first intermediate frequency signal;
- a first amplifier coupled to the first frequency mixer and configured to amplify the first intermediate frequency signal so as to generate a first analog signal;
- a first analog-to-digital converter coupled to the first amplifier and configured to convert the first analog signal to a first digital signal;
- a phase adjustment unit coupled to the first frequency divider and configured to receive the first frequency-divided signal and adjust a phase of the first frequency-divided signal so as to generate a phase shift signal;
- a second frequency mixer coupled to the phase adjustment unit and the second frequency divider, and configured to mix frequencies of the phase shift signal and the second frequency-divided signal so as to generate a second intermediate frequency signal;
- a second amplifier coupled to the second frequency mixer and configured to amplify the second intermediate frequency signal so as to generate a second analog signal;
- a second analog-to-digital converter coupled to the second amplifier and configured to convert the second analog signal to a second digital signal; and
- a digital signal processor coupled to the first analog-to-digital converter and the second analog-to-digital converter, and configured to demodulate the first digital signal and the second digital signal so as to generate the displacement signal.

12. The detector of claim 1, wherein the oscillation source comprises a phase-locked loop configured to improve stability of the first injection signal.

13. A frequency multiplier comprising:

a first injection terminal configured to receive a first injection signal having a first frequency;  
an output terminal configured to output an output signal;  
and

a second injection terminal configured to receive a second injection signal having a second frequency;

wherein the frequency multiplier outputs the output signal at a frequency equal to a multiple of the first frequency by injection locking, and pulls the output signal to the second frequency by injection pulling.

\* \* \* \* \*