



(12) **EUROPEAN PATENT APPLICATION**

(88) Date of publication A3:
27.09.2023 Bulletin 2023/39

(51) International Patent Classification (IPC):
B60T 8/17 (2006.01)

(43) Date of publication A2:
16.08.2023 Bulletin 2023/33

(52) Cooperative Patent Classification (CPC):
**B60T 8/1703; B60T 7/042; B60T 13/662;
 B60T 17/22; B60T 17/221; B60T 13/741;
 B64C 25/42**

(21) Application number: **23152932.2**

(22) Date of filing: **23.01.2023**

(84) Designated Contracting States:
**AL AT BE BG CH CY CZ DE DK EE ES FI FR GB
 GR HR HU IE IS IT LI LT LU LV MC ME MK MT NL
 NO PL PT RO RS SE SI SK SM TR**
 Designated Extension States:
BA
 Designated Validation States:
KH MA MD TN

(72) Inventors:
 • **GEORGIN, Marc**
Dayton, OH (US)
 • **POISSON, Richard A.**
Avon, CT (US)

(74) Representative: **Dehns**
St. Bride's House
10 Salisbury Square
London EC4Y 8JD (GB)

(30) Priority: **10.02.2022 US 202217668647**

(71) Applicant: **Goodrich Corporation**
Charlotte, NC 28217-4578 (US)

(54) **HYBRID BRAKE SYSTEMS AND METHODS FOR LOAD CELL CALIBRATION**

(57) A braking system (200) for an aircraft may comprise: a brake assembly (118); a hydraulic braking subsystem (202) having a hydraulic brake actuator (217) configured to operate the brake assembly; an electric braking subsystem (204) having an electric brake actuator (219) configured to operate the brake assembly and a load cell (259) configured to measure a force supplied by the electric brake actuator; a hydraulic brake control unit (220) configured to control the hydraulic braking sub-

system; and an electric brake control unit (250) configured to control the electric braking subsystem, the electric brake control unit in operable communication with the hydraulic brake control unit, the electric brake control unit configured to calibrate the load cell by a scale factor based on a measured force from the load cell, a measured hydraulic pressure used to exceed the measured force received from the hydraulic brake control unit, and a piston area of the hydraulic brake actuator.

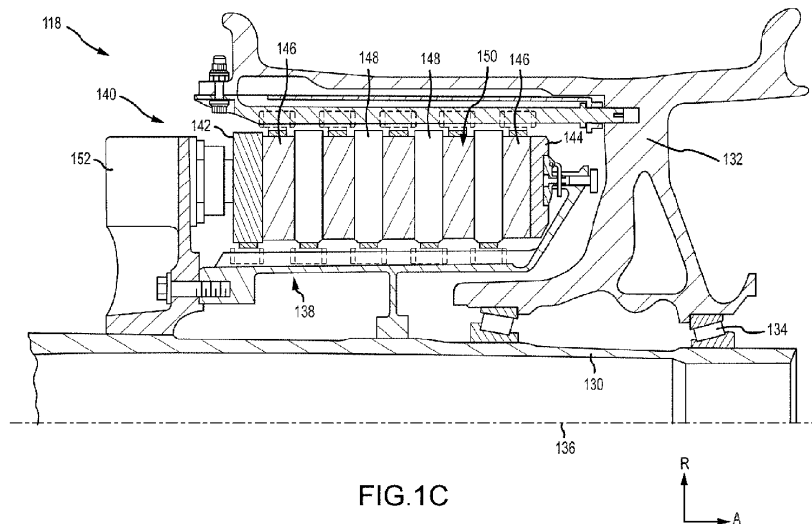

FIG. 1C



EUROPEAN SEARCH REPORT

Application Number
EP 23 15 2932

5

10

15

20

25

30

35

40

45

50

55

DOCUMENTS CONSIDERED TO BE RELEVANT			
Category	Citation of document with indication, where appropriate, of relevant passages	Relevant to claim	CLASSIFICATION OF THE APPLICATION (IPC)
A	JP 2020 050205 A (ADVICS CO LTD) 2 April 2020 (2020-04-02) * paragraphs [0014] - [0049]; figure 1 * -----	1-11	INV. B60T8/17
A	US 2008/116740 A1 (YOKOYAMA ATSUSHI [JP] ET AL) 22 May 2008 (2008-05-22) * paragraphs [0045] - [0050]; figure 1 * -----	1-11	
A	US 2013/276510 A1 (VALDEVIT LORENZO [US] ET AL) 24 October 2013 (2013-10-24) * paragraphs [0060] - [0063]; figure 1 * -----	1	
A	WO 2021/204833 A1 (FOUNDATION BRAKES FRANCE [FR]) 14 October 2021 (2021-10-14) * paragraph [0055]; figure 4 * -----	1-11	
A	US 2016/223415 A1 (BEASON JOSEPH E [US] ET AL) 4 August 2016 (2016-08-04) * paragraph [0014]; figure 1 * -----	1-11	
A	US 2017/267337 A1 (GEORGIN MARC [US]) 21 September 2017 (2017-09-21) * paragraphs [0020] - [0022]; figures 1, 2 * -----	1-11	
The present search report has been drawn up for all claims			
Place of search Munich		Date of completion of the search 11 May 2023	Examiner Raffaelli, Leonardo
CATEGORY OF CITED DOCUMENTS X : particularly relevant if taken alone Y : particularly relevant if combined with another document of the same category A : technological background O : non-written disclosure P : intermediate document		T : theory or principle underlying the invention E : earlier patent document, but published on, or after the filing date D : document cited in the application L : document cited for other reasons & : member of the same patent family, corresponding document	

EPO FORM 1503 03.82 (F04C01)



Application Number

EP 23 15 2932

5

CLAIMS INCURRING FEES

The present European patent application comprised at the time of filing claims for which payment was due.

10

Only part of the claims have been paid within the prescribed time limit. The present European search report has been drawn up for those claims for which no payment was due and for those claims for which claims fees have been paid, namely claim(s):

15

No claims fees have been paid within the prescribed time limit. The present European search report has been drawn up for those claims for which no payment was due.

20

LACK OF UNITY OF INVENTION

The Search Division considers that the present European patent application does not comply with the requirements of unity of invention and relates to several inventions or groups of inventions, namely:

25

see sheet B

30

All further search fees have been paid within the fixed time limit. The present European search report has been drawn up for all claims.

35

As all searchable claims could be searched without effort justifying an additional fee, the Search Division did not invite payment of any additional fee.

40

Only part of the further search fees have been paid within the fixed time limit. The present European search report has been drawn up for those parts of the European patent application which relate to the inventions in respect of which search fees have been paid, namely claims:

45

None of the further search fees have been paid within the fixed time limit. The present European search report has been drawn up for those parts of the European patent application which relate to the invention first mentioned in the claims, namely claims:

50

1-12

55

The present supplementary European search report has been drawn up for those parts of the European patent application which relate to the invention first mentioned in the claims (Rule 164 (1) EPC).

**LACK OF UNITY OF INVENTION
SHEET B**

Application Number

EP 23 15 2932

5

The Search Division considers that the present European patent application does not comply with the requirements of unity of invention and relates to several inventions or groups of inventions, namely:

10

1. claims: 1-12

a brake system for aircraft comprising hydraulic brake actuator and electric brake actuator each controlled by dedicated controller and a load cell calibrated by the electric brake controller using the hydraulic pressure and piston area

15

20

2. claims: 12-15

a computer memory comprising data which cause a processor to update a scale factor every time a load cell is calibrated, count the number of times a load cell has been re-calibrated using the updated scale factor value and notify said number of times

25

30

35

40

45

50

55

ANNEX TO THE EUROPEAN SEARCH REPORT
ON EUROPEAN PATENT APPLICATION NO.

EP 23 15 2932

5 This annex lists the patent family members relating to the patent documents cited in the above-mentioned European search report.
The members are as contained in the European Patent Office EDP file on
The European Patent Office is in no way liable for these particulars which are merely given for the purpose of information.

11-05-2023

Patent document cited in search report	Publication date	Patent family member(s)	Publication date
JP 2020050205 A	02-04-2020	NONE	
US 2008116740 A1	22-05-2008	CN 101044045 A	26-09-2007
		EP 1808347 A1	18-07-2007
		JP 4700010 B2	15-06-2011
		JP WO2006046318 A1	22-05-2008
		US 2008116740 A1	22-05-2008
		WO 2006046318 A1	04-05-2006
US 2013276510 A1	24-10-2013	NONE	
WO 2021204833 A1	14-10-2021	CN 115379973 A	22-11-2022
		EP 4132823 A1	15-02-2023
		FR 3109250 A1	15-10-2021
		WO 2021204833 A1	14-10-2021
US 2016223415 A1	04-08-2016	EP 3059132 A1	24-08-2016
		US 2016223415 A1	04-08-2016
		US 2018045593 A1	15-02-2018
US 2017267337 A1	21-09-2017	EP 3225475 A1	04-10-2017
		US 2017267337 A1	21-09-2017