

(19)



(11)

EP 3 928 528 B1

(12)

EUROPEAN PATENT SPECIFICATION

(45) Date of publication and mention of the grant of the patent:
05.06.2024 Bulletin 2024/23

(51) International Patent Classification (IPC):
H04R 1/02 ^(2006.01) **H04R 9/02** ^(2006.01)
H04R 9/06 ^(2006.01)

(21) Application number: **20701320.2**

(52) Cooperative Patent Classification (CPC):
H04R 1/025; H04R 9/025; H04R 9/06;
H04R 2400/11; H04R 2499/13

(22) Date of filing: **20.01.2020**

(86) International application number:
PCT/EP2020/051297

(87) International publication number:
WO 2020/169288 (27.08.2020 Gazette 2020/35)

(54) **LOUDSPEAKER SYSTEM**

LAUTSPRECHERSYSTEM

SYSTÈME DE HAUT-PARLEUR

(84) Designated Contracting States:
AL AT BE BG CH CY CZ DE DK EE ES FI FR GB GR HR HU IE IS IT LI LT LU LV MC MK MT NL NO PL PT RO RS SE SI SK SM TR

(74) Representative: **Mewburn Ellis LLP**
Aurora Building
Counterslip
Bristol BS1 6BX (GB)

(30) Priority: **21.02.2019 GB 201902360**

(56) References cited:
EP-A1- 1 515 583 EP-A2- 0 510 345
EP-A2- 0 939 577 WO-A1-2004/064448
DE-A1- 4 434 719 JP-A- 2001 352 591
JP-A- 2002 281 598 US-A- 2 834 423
US-A- 5 532 437

(43) Date of publication of application:
29.12.2021 Bulletin 2021/52

(73) Proprietor: **PSS Belgium NV**
9200 Dendermonde (BE)

(72) Inventor: **SCHEPENS, Johan**
9200 Dendermonde (BE)

EP 3 928 528 B1

Note: Within nine months of the publication of the mention of the grant of the European patent in the European Patent Bulletin, any person may give notice to the European Patent Office of opposition to that patent, in accordance with the Implementing Regulations. Notice of opposition shall not be deemed to have been filed until the opposition fee has been paid. (Art. 99(1) European Patent Convention).

Description

Field

[0001] The present disclosure relates to the field of loudspeaker systems. In particular, the disclosure relates to loudspeakers and loudspeaker assemblies comprising a loudspeaker enclosure and a loudspeaker, which are for use in the automotive industry.

Background

[0002] A loudspeaker comprises, *inter alia*, a diaphragm, which is displaceable to transmit pressure waves as audible sound. The diaphragm is driveably coupled to a magnet and voice coil assembly, which is operable to convert electrical energy to axial displacement to provide said driving of the diaphragm. A basket interconnects the diaphragm and magnet and voice coil assembly providing a rigid frame to convey said drive. The basket is also connectable to an enclosure for mounting of the loudspeaker.

[0003] In conventional loudspeakers, the basket is designed to be highly rigid for the purpose of conveying with high accuracy said axial displacement to the diaphragm. In the automotive industry, such loudspeakers are mounted within a dedicated loudspeaker enclosure, which is typically arranged within a door or under carriage of the vehicle. The enclosure may also be configured in various ways to reduce noise leakage outside the vehicle. The loudspeaker may be arranged with the diaphragm facing a passenger of the vehicle for optimal transmission of audio information thereto.

[0004] A drawback with this implementation is that in the event of impact to the door or undercarriage, the loudspeaker can project into the passenger causing harm.

[0005] Therefore, in spite of the effort already invested in the development of loudspeakers and their enclosures further improvements are desirable.

[0006] EP0510345A1 discloses a loudspeaker for use in a vehicle.

[0007] WO2004/064448A1 discloses a loudspeaker for use in a vehicle.

[0008] DE19649140A1 discloses a loudspeaker for use in a vehicle.

[0009] FR2944753A1 discloses a loudspeaker for use in a vehicle.

[0010] GB2165419, US2004/0208336, US2013/0126263 disclose loudspeakers.

Summary

[0011] The present disclosure provides a loudspeaker system according to claim 1.

[0012] By connecting the magnet assembly to the back face and/or side face of the enclosure load can be conveyed directly from the enclosure to the loud speaker system to enable a controlled and directed failure mechanism, e.g. such that the basket collapses in a particular manner, and/or (particularly in embodiments without a basket) such that said components of the speaker are brought together in a particular manner and remain connected to the enclosure. By implementing a collapsible basket, or no basket, the loudspeaker assembly can be configured to collapse with the enclosure and without projecting beyond the collapsed enclosure.

5

[0013] The mechanical coupling between the magnet assembly and the back face and/or side face of the enclosure provides a rigid attachment between the magnet assembly and the enclosure such that the magnet assembly remains attached to and/or retained within the enclosure in the event of a load being applied to the loudspeaker system which causes the loudspeaker system to collapse. The load which causes the loudspeaker system to collapse may be a predetermined load. The load which causes the loudspeaker system to collapse may correspond to (e.g. be equal to) the failure load of the loudspeaker system.

[0014] In this context, a rigid attachment between the magnet assembly and the enclosure is intended to mean that the magnet assembly is held rigidly in place with respect to the loudspeaker enclosure, noting that this attachment can be achieved directly or indirectly as described in the following paragraphs. The term "provide a rigid attachment between the magnet assembly and the enclosure" may be used interchangeable "hold the magnet assembly rigidly in place with respect to the enclosure".

[0015] In a conventional loudspeaker system mounted in (e.g. a door of) a vehicle, there is no rigid attachment between the magnet assembly and the enclosure, and as such, in the event of a sudden impact (e.g. caused by the vehicle crashing), the magnet assembly (which is often the heaviest component of a loudspeaker assembly) can be launched as a projectile out from the enclosure. The present inventors have observed this is a potential hazard for the passengers within the vehicle.

[0016] Advantageously, by providing a rigid attachment between the magnet assembly and the enclosure as described above, the magnet assembly can be prevented from being projected out from the enclosure, in the event of a sudden impact (e.g. caused by the vehicle crashing), thereby improving safety.

[0017] Although the concept of rigidly attaching a magnet assembly to a loudspeaker enclosure does appear to have been considered in the prior art, see e.g. GB2165419, US2004/0208336, US2013/0126263, the prior art only appears to envisage doing so for the purpose of reducing vibrations. The prior does not appear to have considered rigidly attaching a magnet assembly to a loudspeaker enclosure in combination with collapsible loudspeaker system to prevent the magnet assembly from being projected out from the enclosure in the event of a sudden impact, as considered by this disclosure.

[0018] The mechanical coupling between the magnet assembly and the back face and/or side face of the en-

closure (e.g. which preferably provides a rigid attachment between the magnet assembly and the enclosure - see above) may be provided by one or more physical connectors, wherein the/each physical connector engages with both the magnet assembly and the enclosure. The/each physical connector could, for example, be a bolt, screw, rod or pin (e.g. a screw which threadably engages with a hole in the magnet assembly and a corresponding hole in the back face and/or side face of the enclosure). The one or more physical connectors described in this paragraph can be viewed as providing a direct connection or direct attachment between the magnet assembly and the enclosure.

[0019] The mechanical coupling between the magnet assembly and the back face and/or side face of the enclosure (e.g. which preferably provides a rigid attachment between the magnet assembly and the enclosure - see above) may be provided by glue. Again, this glue can be viewed as providing a direct connection or direct attachment between the magnet assembly and the enclosure.

[0020] However, the mechanical coupling between the magnet assembly and the back face and/or side face of the enclosure (e.g. which preferably provides a rigid attachment between the magnet assembly and the enclosure - see above) may be provided without requiring direct attachment between the magnet assembly and the enclosure.

[0021] For example, the mechanical coupling between the magnet assembly and the back face and/or side face of the enclosure (e.g. which preferably provides a rigid attachment between the magnet assembly and the enclosure - see above) may be provided (indirectly) by a physical element (e.g. flange) configured to retain the magnet assembly in position with respect to the back face and/or side face of the enclosure (e.g. by overlapping the magnet assembly in a direction which is transverse to a direction in which the magnet and voice coil assemblies are configured to move the diaphragm) wherein the flange is rigidly coupled to (e.g. the back face and/or side face of) the enclosure. The flange may be rigidly coupled to the enclosure directly, or indirectly via one or more intermediate components (e.g. mounting members as discussed below).

[0022] In some embodiments, the front face of the enclosure comprises an aperture corresponding to the diaphragm for transmission of the audible sound to a user. The diaphragm may be connected (e.g. directly or indirectly) around a periphery of said aperture.

[0023] According to the disclosure, when subject to a compressive force between the back and front face, the loudspeaker system is configured to collapse at substantially the failure load of the enclosure, wherein said collapsing includes reduction in a distance between the magnet assembly and diaphragm of the loud speaker assembly.

[0024] By configuring the loudspeaker system to collapse at substantially the failure load of the enclosure, e.g. a failure load of faces interconnecting the back and

front faces and/or said back and/or front faces, the loudspeaker assembly may be fully collapsed within the enclosure, which may be safer for a proximal user.

[0025] In some embodiments, the loudspeaker system is configured to collapse between a range extending from the failure load of the enclosure to less than 30% or 20% more than the failure load of the enclosure.

[0026] In some embodiments, when subject to a compressive force between the back and front face, the loudspeaker system is configured to collapse at a threshold load which is selected to be less than 5000 N or 3000 N or 2000 N or 1000 N and greater than 500 N. By configuring the loudspeaker system to collapse at said ranges, it has been found that collapsing can occur when subject to impact in a safe manner, whilst maintaining sufficient rigidity for the desired audio performance.

[0027] In some embodiments wherein the loudspeaker assembly comprises a collapsible basket, the collapsible basket may be configured to collapse at less than the failure load of the enclosure, e.g. at less than 30% or 20% of the failure load of the enclosure. By configuring the loudspeaker assembly to collapse at less than the failure load of the enclosure, it can be ensured that the failure load of the enclosure substantially controls a failure load of the loudspeaker system.

[0028] In some embodiments, the collapsible basket is configured to collapse at less than 500 N. In embodiments, the collapsible basket is configured to collapse at greater than 100 N. By configuring the basket to collapse at said ranges, it has been found that collapsing can occur when subject to impact in a safe manner (e.g. without substantially effecting the failure load of the enclosure) whilst maintain sufficient rigidity for the desired audio performance.

[0029] In some embodiments wherein the loudspeaker assembly comprises a basket, the basket may include a plurality of axially extending members interconnecting a diaphragm support and a magnet and voice coil support, said members removably attached to the diaphragm support and the magnet and voice coil support. By implementing said removable members, the basket can be implemented to ensure the correct positioning of the magnet assembly, voice coil assembly and diaphragm, when arranging and connecting the loudspeaker assembly to/in the enclosure. The removable members may subsequently be removed once said connection has taken place.

[0030] In some embodiments wherein the loudspeaker assembly comprises a basket, the basket may include a plurality of axially extending members interconnecting a diaphragm support and a magnet assembly support, said members comprising a weakening section configured to collapse under a compressive load applied between the diaphragm support and a magnet assembly support. By implementing a weakening section, the basket can be configured to collapse at a particular point in a controlled manner when subject to said load.

[0031] In some embodiments, wherein the enclosure

comprises a walled structure interconnecting the back face and front face. By implementing a walled structure the enclosure can be configured to collapse with a consistent failure mode and at a specific threshold load.

[0032] Preferably, the enclosure is configured to be mounted in (e.g. a door or an under carriage of) a motorized passenger vehicle.

[0033] Disclosed herein is a motorized passenger vehicle comprising the loudspeaker system of any preceding embodiment, or another embodiment disclosed herein. In embodiments, the loudspeaker system is arranged in a door and/or under carriage of said vehicle.

[0034] Disclosed herein is use of any preceding embodiment, or another embodiment disclosed herein, for a motorized passenger vehicle.

[0035] Disclosed herein is a method of assembling a loudspeaker system according to claim 14.

[0036] In some embodiments, when a loudspeaker assembly implements a basket and said basket includes removable members to interconnect the diaphragm and magnet assembly, the method comprising, subsequent to connecting of the loudspeaker assembly to the enclosure (e.g. connecting the diaphragm to a front face of the enclosure; connecting the magnet assembly to a back and/or side face of the enclosure) removing the removable members.

[0037] The preceding summary is provided for purposes of summarizing some embodiments to provide a basic understanding of aspects of the subject matter described herein. Accordingly, the above-described features are merely examples and should not be construed to narrow the scope or spirit of the subject matter described herein in any way. Moreover, the above and/or proceeding embodiments may be combined in any suitable combination to provide further embodiments. Other features, aspects, and advantages of the subject matter described herein will become apparent from the following Detailed Description, Figures, and Claims.

Summary of the Figures

[0038] Aspects, features and advantages of embodiments of the present disclosure will become apparent from the following description of embodiments in reference to the appended drawings in which like numerals denote like elements.

Figure 1 is an illustrative view showing an embodiment loudspeaker system arranged in a vehicle door.

Figures 2A and 2B are a side cross-sectional schematic view showing a loudspeaker assemblies of the embodiment loudspeaker system of figure 1.

Figure 3 is a side cross-sectional view showing an embodiment basket of the loudspeaker of the loudspeaker system of figure 2A or 2B.

Figures 4A to 4C are illustrative plan views of embodiment collapsible members for implementation on the basket of figure 3.

Figures 5 to 6 are various views showing embodiment loudspeakers for implementation in the loudspeaker system of figure 1.

Figure 7 is a perspective view of the loudspeaker of figures 5 and 6 arranged in a loudspeaker enclosure.

Figures 8 to 9 are various views showing embodiment loudspeakers for implementation in the loudspeaker system of figure 1.

Figure 10 is a perspective view of the loudspeaker of figures 8 and 9 arranged in a loudspeaker enclosure.

Figures 11 and 12 are side cross-sectional views showing embodiment implementations of the loudspeaker system of figure 1.

Figures 13 and 14 are side cross-sectional views showing embodiment implementations of the loudspeaker system of figure 1.

Figure 15 is a side cross-sectional views showing embodiment implementations of the loudspeaker system of figure 1.

Detailed Description of the Invention

[0039] Before describing several embodiments of a loudspeaker system, it is to be understood that the system is not limited to the details of construction or process steps set forth in the following description. It will be apparent to those skilled in the art having the benefit of the present disclosure that the system is capable of other embodiments and of being practiced or being carried out in various ways.

[0040] The present disclosure may be better understood in view of the following explanations:

As used herein the term "**vehicle**" may refer to a device used for transporting people or goods, especially on land, such as a car, lorry, or van. The vehicle may be motorised.

[0041] As used herein the term "**vehicle door**" may refer to a type of door, typically hinged, but sometimes attached by other mechanisms such as tracks, in front of an opening which is used for entering and exiting the vehicle. A vehicle door can be opened to provide access to the opening, or closed to secure it. The doors can be opened manually, or powered electronically.

[0042] As used herein the term "**loudspeaker**" or "**loudspeaker assembly**" (these terms may be used interchangeably) may refer to an electroacoustic transducer, which converts an electrical audio signal into a corresponding sound by pushing on the air to create sound

waves. The loudspeaker includes an assembly of components including a diaphragm, voice coil assembly, magnet assembly.

[0043] As used herein the term "**loudspeaker enclosure**" or "**enclosure**" or "**cabinet**" (these terms may be used interchangeably) may refer a unit in which the loudspeaker as defined herein, and optionally associated electronic hardware, such as crossover circuits and, in some cases, power amplifiers, are mounted. The enclosure may include internal baffles, horns, bass reflex ports and acoustic insulation. The enclosure may be formed from any suitable material, including composite materials, plastics, wood. The enclosure may be implemented to prevent sound waves generated by the rearward-facing surface of a diaphragm of the loudspeaker interacting with sound waves generated at the front of the speaker driver. The enclosure may be implemented to reduce noise leakage outside the vehicle, which may cause irritation to people outside the vehicle or for privacy of the passenger. The enclosure may be any suitable dimension for housing the loud speaker, e.g. square, rectangular or cylindrical. A loudspeaker enclosure would typically enclose a defined volume, which volume may typically be 3 litres or more, or in some cases 4 litres or more. A loudspeaker enclosure would typically substantially enclose the defined volume, e.g. to provide a desired acoustic effect. For avoidance of any doubt, it is possible for a loudspeaker enclosure to include one or more apertures, e.g. to provide a desired acoustic effect, whilst still substantially enclosing the defined volume. In this way, a loudspeaker enclosure can be understood as something very different to a basket typically used to interconnect the diaphragm and magnet in a loudspeaker, since a typical basket has an open structure that does not substantially enclose a defined volume and is not configured to provide a desired acoustic effect. Moreover, to the extent that the open structure of a typical basket could be viewed as "containing" a volume, the volume "contained" by a typical basket is much smaller than 3 litres (and might typically be around 0.5 litres).

[0044] As used herein the term "**collapsible**" or "**collapse**" or "**collapsible member**" may refer a member or unit that is arranged to collapse under a particular load. The collapsing can be elastic (i.e. reversible), plastic or a combination thereof. The collapsing can include folding, breakage, buckling of a combination thereof.

[0045] Referring to figure 1, a vehicle door **2** of a motorised passenger vehicle (not shown) includes a loudspeaker **4**. The loudspeaker system **4** includes a loudspeaker enclosure **6** and a loudspeaker **8** arranged within said enclosure **6**. It will be understood from the figure that a side impact to the vehicle door along line may cause an axial force **F** to be transmitted through the loudspeaker system **4**. Said axial force causes collapsing of the enclosure **6** and the loudspeaker **8** as will be discussed. It is preferable for both components to collapse since the likelihood for the axial force being transmitted to a passenger of the vehicle, arranged adjacent the door, is less.

[0046] In variant embodiments, which are not illustrated, the loudspeaker **4** is arranged in other portions of the vehicle, which are generally passenger facing and/or arranged to receive an impact load in the event an exterior of the vehicle is subject to impact.

[0047] Referring to figure **2A**, a loudspeaker **8** comprises: a diaphragm **10**, which is displaceable to transmit pressure waves as audible sound and a magnet and voice coil assembly **12**, which is operable to convert electrical energy to axial displacement to provide said driving of the diaphragm **10**. The loudspeaker further comprises a basket **14** interconnects the diaphragm **10** and magnet and voice coil assembly **12** providing a rigid frame to convey said drive. The basket **14** is connectable to the loudspeaker enclosure **6** for mounting of the loudspeaker **8**.

[0048] The diaphragm **10** includes a surround **16**, which is an elastic portion of material for connection of the diaphragm to the basket **14**. A dust cap **17** may be arranged at the centre of the diaphragm to protect the voice coil.

[0049] The magnet and voice coil assembly **12** includes a magnet assembly **18**, which may comprise one or more permanent magnets **20** arranged around a pole piece **22**. The optional pole piece **22** is arranged to concentrate the magnetic field produced by the voice coil. The magnet and voice coil assembly **12** further includes a voice coil assembly **24**, which receives electrical energy from an electrical energy source to displace the diaphragm **10**. The voice coil may be wound onto an optional former **25**. An optional spider **27** may hold the voice coil on place with respect to the diaphragm.

[0050] Referring to figure **2B** an alternative loudspeaker **8** configuration is provided with like reference numbers indicating like parts. In this embodiment, the magnet assembly **18** is alternatively comprises part **20a** that extends around a periphery of the voice coil **24** and part **20b** arranged within the voice coil **24**.

[0051] Referring to figure **3**, the basket **14** comprises a diaphragm support **26** arranged at a first end of the basket, the diaphragm support **26** adapted to support the loudspeaker diaphragm **10** and to connect to a loudspeaker enclosure **6**. The diaphragm support **26** may comprise a flanged portion for connection via adhesive, or other means, to the surround **16** of the diaphragm **10**. The diaphragm may be adapted (e.g. by a plurality of holes) to receive fixtures, e.g. threaded connector such as a bolt or similar or a pin e.g. a rivet or a split pin or similar, for connection to the loudspeaker enclosure **6**.

[0052] The basket **14** comprises a magnet and voice coil assembly support **28** arranged at a second end of the basket adapted to support the magnet and voice coil assembly **12**, (including just the magnet assembly **18** thereof, hence herein the magnet and voice coil assembly support **28** may be referred to as a magnet assembly support **28**). The magnet and voice coil assembly support **28** may comprise a flanged portion for connection via adhesive, or other means, to the support the magnet and voice coil assembly **12**, e.g. to the **20** permanent magnet

or another component of the magnet and voice coil assembly 12.

[0053] The basket comprises a one or more collapsible member(s) 30, e.g. any number between 2 to 20, which extending axially between the a diaphragm support 26 and the a magnet and voice coil support 28, wherein the collapsible members 30 are configured to collapse in an axial direction when the diaphragm support and magnet and voice coil support are subject of a compressive load **F** in the axial direction. The axial direction is to be defined as a direction parallel to an axis 32, which extends through a rotational axis of symmetry of the diaphragm 10 and magnet and voice coils assembly 12 and from the latter to the former (referred to as a first direction).

[0054] Herein, the first direction may be defined as direction in which the magnet and voice coil assemblies are configured to move the diaphragm, when the loudspeaker system is in use.

[0055] The compressive load **F** at which said collapsible members collapse (i.e. the load for the assembly of all the said members as opposed to a single member in an assembly comprising multiple members) is selected to be greater than a predetermined threshold. Said threshold may be with in an envelope from greater than 100 N to less than 2000 or 1000 or 500 N.

[0056] The collapsible members 30 include a collapsible portion 34, which may be referred to as a weakening, configured to collapse at said threshold. The collapsible portion 34 may extend the length of the collapsible member 30 or be arranged at one or more positions along its length. Moreover, in the embodiments, whilst the collapsible member is said to collapse under the threshold loading conditions, other portions of the collapsible member are not precluded from collapsing.

[0057] The collapsible portion 34 may be formed of a material and/or with geometry adapted to collapse at said threshold. For example, it may take any suitable shape of form but be made of rubber (e.g. an elastically deformable material), or plastic or a low strength alloy (e.g. a plastically deformable material) or other like material, which provides a configuration for collapsing at the threshold.

[0058] The collapsible member 30 is configured to collapse when the basket is subject to said loading conditions to decrease an axial distance between the magnet and voice coil assembly support 28 and the diaphragm support 26.

[0059] Examples are provided in figures 4A to 4C, wherein:

Figure 4A illustrates a collapsible member 30 with a single collapsible portion 34, which is formed of a material to introduce a weakening, e.g. with a lower Young's modulus, such as rubber or plastic, than for the remainder of the collapsible member, which may be an alloy.

Figure 4B illustrates a collapsible member 30 with a

multiple collapsible portions 34, which are configured as described for the embodiment associated with figure 4A.

5 Figure 4C illustrates a collapsible member 30 with a collapsible portion 34 comprising an opening arranged along the length of said member.

[0060] Referring to figures 5 to 7, wherein like reference numerals are used to designate like parts, the collapsible member 30 includes a collapsible portion 34 with an opening 36 arranged to deform, e.g. close or open or otherwise change in geometry, when the basket 14 is subject to said compressive load. Said openings introduce a weakening for selectively collapsing at a particular load however they provide sufficient rigidity under normal conditions so as not to effect sound of a loudspeaker. Whilst in the illustrated embodiment there are four collapsible members, it will be understood that any suitable number may be implemented, e.g. 2, 3, 5, 6 or other number.

[0061] In particular, an opening 36 is formed by a first portion 38 and a second portion 40, which are interconnected, and inclined to each other and adjoin at an apex 42. The two portions 38, 40 may be interconnected along a fold line. The opening 36 is arranged to extend substantially in a radial direction with respect to axis 32. The first portion 38 is arranged to extend directly from the magnet and voice coil support 28 in a second direction (which is opposed to the first direction extending axially along the axis 32 from the magnet and voice coil support 28 to the diaphragm support 26) and radially outward. The second portion 40 extends from the first portion 38 in the first direction and radially outward to axially overlap at least part of the first portion.

[0062] Herein, the second direction may be defined as a direction which is transverse to a direction in which the magnet and voice coil assemblies are configured to move the diaphragm (i.e. transverse to the first direction), when the loudspeaker is in use.

[0063] The collapsible member 30 includes a third portion 48 to extend from the second portion 40, the third portion connected to the diaphragm support 26. The third portion 48 may extend axially and inclined to the axial direction, such that it tapers radially outwardly to the diaphragm support 26 with respect to axis 32.

[0064] The magnet and voice coil support 28 is adapted to support the magnet and voice coil assembly on an exterior face 44 thereof that faces away from the diaphragm support 26 and the collapsible member 30 is arranged to partially overlap in the axial direction the supported magnet and voice coil assembly 12.

[0065] In an embodiment, which is not illustrated, the opening 36 is alternatively arranged. For example, it may face away from the diaphragm support 26. With such an example, first portion 38 is arranged to extend directly from the magnet and voice coil support 28 in the first direction and a second portion 40, is interconnected to

the first portion **38** and adjoin at an apex **42**. A third portion **48** extends from the second portion **40**, the third portion connected to the diaphragm support **26**. Thus in this example the opening **36** is inverted in comparison to the example shown in figure 5 to 8.

[0066] Referring to figure 7, the loudspeaker **8** is arranged in the loudspeaker enclosure **6** to provide a loudspeaker system. The magnet assembly **12** and a back face **50** of the loudspeaker enclosure **6** are adapted for being mechanically coupled to each other, so as to provide a rigid attachment between the magnet assembly **12** and the enclosure **6**, preferably such that the magnet assembly **12** remains attached to (and thus retained within) the enclosure **6** in the event of a load being applied to the loudspeaker system which causes the loudspeaker system to collapse. In particular, the magnet and voice coil assembly **12** includes a hole **56** arranged on axis **32** for receiving a bolt **58** through a corresponding hole **60** of the back face **50**. The bolt **58** and hole **56** are adapted for threaded connection, so as to provide the rigid attachment.

[0067] In embodiments, which are not illustrated, alternative mechanical connection configurations may be implemented so as to provide the rigid attachment between the magnet assembly **12** and the enclosure **6**, for example: any threaded connector, such as a bolt or screw or similar may be implemented, the threaded connector may be integrated on the magnet and voice coil assembly and extend through the hole in the enclosure for receiving a nut; a pin be integrated on the magnet and voice coil assembly and extend through the hole in the enclosure for receiving a corresponding pin, or for securing by mechanical deformation; an adhesive strip may be arranged between the magnet and voice coil assembly and the back face; the connection may be to a side face of the enclosure, e.g. via a bracket. Alternatively glue may be used. Moreover, the connection can be arranged in any suitable location, e.g. figure 7 illustrates the threaded connection arranged aligned with a central axis of the magnet, the connection may also be arranged be about said central axis or a combination thereof.

[0068] Referring to figures 8 to 10, a variant of the prior embodiment shows the magnet and voice coil assembly support **28** with mounting members **60** at least partially extending therefrom. In this example, there are four mounting members **60**, each of which comprise collar **62** (here the collar **62** is the top of the mounting members **60**, as depicted in Fig. 9). The collar **62** extends (i.e. has a thickness which extends) in the second direction to provide a mounting surface which abuts the back face **50** of the enclosure **6**. The collar **62** of each of the mounting members **60** provides a hole, which permits the mounting members **60** to be rigidly attached to the back face **50** of the enclosure **6**, in this example via screws which threadably engage with the holes in the mounting members **60** and corresponding holes in the back face **50** of the enclosure **6**. The collar **62** extends so as to overlap in the axial direction (first direction) the magnet

assembly **12**.

[0069] The mounting members **60** are rigidly connected to a flange **60a** (in this example about midway along the length of the mounting members). The flange **60a** overlaps the magnet assembly **12** in the second direction, and is rigidly attached to the back face **50** of the enclosure **6**, via the mounting members. Thus, the flange (indirectly) provides a rigid attachment between the magnet assembly **12** and the back face **50** of the enclosure **6**, via the mounting members **60**, by retaining the magnet assembly **12** in position with respect to the back face **50** of the enclosure **6**.

[0070] The flange **60a** is shown schematically in Fig. 9b, with the back face **50** of the loudspeaker enclosure **6** shown only in part in this drawing.

[0071] The connection of the mounting members **60** to a back face **50** of the enclosure **6** (as will be discussed) can additionally/alternatively be implemented according to any of the various examples described for the prior embodiment shown in Fig. 7, which concerned connection between the back face and the magnet and voice coil assembly.

[0072] In embodiments, which are not illustrated, the/each mounting member **60** may extend entirely from the magnet and voice coil support **28** or the collapsible member **30**. There may be any suitable number of mounting members, e.g. 1, 2, 3, 5, 6 or other number. The mounting member may extend laterally for engagement with the side face of the loudspeaker enclosure. In such an example, any of the previously described connection configurations may be implemented.

[0073] Referring to figures 11 and 12, the illustrated embodiment may include any feature of the other embodiments disclosed herein, the collapsible member **30** includes collapsible portions **34** arranged as openings **36** that extend in the axial direction.

[0074] In particular referring initially to figure 11, which shows the collapsible portions **34** in a non-collapsed state, the opening **36** of collapsible portion **34A** is formed by a first portion **38** and a second portion **40**, which are interconnected, and inclined to each other and adjoin at an apex **42**. The two portions may be interconnected along a fold line. The opening **36** is arranged to extend substantially in an axial direction with respect to axis **32**. The first portion **38** is arranged to extend directly from the magnet and voice coil support **28** in the first direction and radially outward. The second portion to extend from the first portion in the first direction and radially outward to axially overlap in the radial direction at least part of the first portion.

[0075] Referring to figure 12, the collapsible portions **34** are shown in a collapsed state, wherein the first portion **38** and second portion **40** have displaced axially from the un-collapsed state to close opening **36**. In particular, said portions are arranged contiguous each other.

[0076] In embodiments, which are not illustrated, each collapsible member **30** can include one or more of said collapsible portions (there are two provided in said fig-

ure). Moreover, a collapsible portion may not be arranged immediately adjacent the magnet and voice coil support **28**.

[0077] In embodiments, which are not illustrated, the basket **14** is configured with the magnet and voice coil support **28** adapted to support the magnet and voice coil assembly on an interior face thereof that faces from the diaphragm support **26**. It will be understood that all of the collapsible members as described herein may be implemented with such a basket configuration.

[0078] Referring to figure 11, a loudspeaker system **4** comprises the embodiment loudspeaker **8** shown arranged in enclosure **6**. The magnet assembly **18** is rigidly attached (and thus connected) to the back face **50** of the enclosure **6** by means of a connector implemented as a bolt **72** threadably engaged with hole **74** in the magnet assembly **18** and a corresponding hole in the back face **50**. The diaphragm support **26** of the basket **14** are connected to a front face **52** of the enclosure **6** by means of an adhesive connection **76**. In embodiments, the mounting members **60** are connected to the back face **50** of the enclosure **6** by means of a connector implemented as a bolt **80** threadably engaged with hole **82** in the magnet assembly **18** and back face **50**. In variant embodiments, which are not illustrated, other connection configurations may be implemented, for any of the connections in the preceding paragraph, e.g.: the connector can be arranged as a screw, rod or pin; both holes may be absent a thread with the thread alternatively implemented on a nut; an adhesive connection may be implemented by an adhesive strip.

[0079] Referring to figure 12, the loudspeaker system **4** of figure 11 is illustrated in a collapsed state. In particular, side faces **54** interconnecting the back face **50** and front face **52** have collapsed such that the separation between the back face **50** and front face **52** along axis **84** is reduced. In a similar manner the collapsible member(s) **30** of the basket **14** have collapsed (by means of buckling) such that the separation between the magnet assembly **18** and diaphragm **10** along axis **84** is reduced. The magnet assembly **18** thus remains attached to the back face **50** of the loudspeaker enclosure **6** (e.g. even in the event of a load being applied to the loudspeaker system which causes the loudspeaker system to collapse), enabling controlled collapsing and retention of heavy components of the loudspeaker **8** within the enclosure **6**.

[0080] In variant embodiments, which are not illustrated, the basket does not comprise mounting members **60**, e.g. the magnet assembly **18** could be rigidly attached to the enclosure **6** by one or more physical connectors (e.g. one or more screws threadably attaching the magnet assembly **18** to the enclosure **6**), without involving any mounting members **60**. In embodiments, the magnet support **28** is arranged behind the magnet assembly **18**.

[0081] Referring to figures 13 and 14, a loudspeaker system **4** with an inverted driver configuration is shown. Again, the magnet assembly **18** is rigidly attached to an

enclosure by a physical connector **72**, such as a screw. In this embodiment, the diaphragm **10** is arranged to the emit audible sound towards the front face **52**, and the basket **14** includes the magnet assembly support **28**, and a diaphragm support **26**, which are interconnected by first axial members **90**. Second axial members **92** extend from diaphragm support **26** to the front face **52**. Third axial members **94** extend from the diaphragm support **26** for support of the spider **27**, and include perforations (not illustrated) for transmission of the audible sound there-through. Referring to figure 14, the second axial members **92** and the third axial members **94** are collapsible as collapsible members **30**.

[0082] In variant embodiments, one or more of the: first axial members **90**; second axial members **92**; third axial members **94**, are configured as collapsible members.

[0083] Referring to figure 15, a loudspeaker system **4** corresponding to the embodiment of figure **11** and **12** is shown. Again, the magnet assembly **18** is rigidly attached to an enclosure **6** by a physical connector **72**, such as a screw. In this embodiment, removable members (not shown) forming the axially extending portions of the basket **14**, which interconnect the magnet assembly support **28**, and a diaphragm support **26** are removably attached to said supports.

[0084] The removable attachment of the removable members includes various implementations, e.g.: a threaded connector can be arranged as a screw or bolt and a nut; rod or pin; an adhesive connection configured to break upon the application of a user applied threshold force may be implemented by an adhesive strip arranged between an overlapping corresponding in shape portions of the member and the diaphragm support or magnet and voice coil assembly.

[0085] Referring to figure 15, a method of assembling a loudspeaker system **4** includes arranging the loudspeaker **8** in the loudspeaker enclosure **6**. With the diaphragm **10** and magnet assembly **18** and voice coil assembly (not shown) held in operative alignment by the basket **14**, the diaphragm is connected to the front face **52** of the enclosure **6** and the magnet assembly **18** is rigidly attached and thus connected to the back face **50** by the physical connector **72** (the magnet assembly **18** could alternatively or additionally be connected to the side face **54**, though this is not shown). Subsequently, with the diaphragm **10** and magnet assembly **18** now held in operative alignment by their connections to the loudspeaker enclosure **6**, the removable members (not shown) are removed as shown in figure 15.

[0086] In variant embodiments, which are not illustrated, a variant of the directly preceding embodiment comprises the inverted driver configuration of figures 14 and 15 implemented with the first axial members **90** as removable.

[0087] In embodiments, which are not illustrated, the diaphragm and magnet and voice coil assembly are each individually connected to the loudspeaker enclosure without implementing the basket to act as an intermediary

guide to ensure they are arranged correctly with respect to each other. In such an embodiment the diaphragm and magnet and voice coil assembly are operatively aligned as part of their connection to the enclosure.

[0088] In the all embodiments, the enclosure **6** comprises a walled structure. Typically it is formed of 1 to 4 mm or 1.8 - 3mm, thick material. The enclosure may be implemented with a ranged of materials, which may be: plastic based, including, Polypropylene, Acrylonitrile Butadiene Styrene, Polycarbonate; fibre reinforced, e.g. Glass Fibre Reinforced Polymer; metal, e.g. an alloy; a combination thereof.

[0089] The side face **54** of the enclosure **6** may be configured to encourage buckling, e.g. geometrically configured and/or configured with points of weakening. Referring to figure 12 and example of said geometric weakening includes the side face **54** with a V-shaped section, although other sections are contemplated, such as U-shaped. An example of points of weakening includes a scored portion of reduced thickness.

[0090] In embodiments, the loudspeaker system **4** is configured, when subject to a mechanical shock test as defined herein, to have no failure modes. Failure modes as used herein may refer to one or more of: failure of the enclosure; failure of components of the loudspeaker assembly; failure of a connection between components of the loudspeaker assembly and the enclosure. By passing the mechanical shock test, i.e. without any failure modes, it can be ensured that the loudspeaker system is suitable for use in a vehicle as defined herein.

[0091] As used herein "**mechanical shock test**" refers to the application, to a test sample loudspeaker system **4**, of 10 half sinusoidal pulses of 500m/s² during 6 ms at 20°C in X, Y and Z directions, wherein the Z direction is in the direction of axis **84** as shown in figure 12, and the Y and X directions are perpendicular to the Z direction and to each other. Said pulses are applied in the three directions X, Y and Z on the same test sample loudspeaker system.

[0092] The loudspeaker system **4** is mounted to a test platform, which is similar to a real-world application, for example a test platform with the same mounting system and configuration as disclosed for the door in figure 1. The loudspeaker system **4** coupled to the test platform is subsequently excited with the aforescribed loading, which is transmitted to the loudspeaker system **4**. In particular, the loudspeaker system **4** coupled to the test platform are accelerated by a drop test from a predefined height and subject to impact with a predefined shock absorbing object, which are configured to ensure the acceleration of 500m/s² and the 6ms duration.

[0093] As used in this specification, any formulation used of the style "at least one of A, B or C", and the formulation "at least one of A, B and C" use a disjunctive "or" and a disjunctive "and" such that those formulations comprise any and all joint and several permutations of A, B, C, that is, A alone, B alone, C alone, A and B in any order, A and C in any order, B and C in any order and A,

B, C in any order. There may be more or less than three features used in such formulations.

[0094] In the claims, any reference signs placed between parentheses shall not be construed as limiting the claim. The word 'comprising' does not exclude the presence of other elements or steps then those listed in a claim. Furthermore, the terms "a" or "an," as used herein, are defined as one or more than one. Also, the use of introductory phrases such as "at least one" and "one or more" in the claims should not be construed to imply that the introduction of another claim element by the indefinite articles "a" or "an" limits any particular claim containing such introduced claim element to inventions containing only one such element, even when the same claim includes the introductory phrases "one or more" or "at least one" and indefinite articles such as "a" or "an." The same holds true for the use of definite articles. Unless stated otherwise, terms such as "first" and "second" are used to arbitrarily distinguish between the elements such terms describe. Thus, these terms are not necessarily intended to indicate temporal or other prioritization of such elements. The mere fact that certain measures are recited in mutually different claims does not indicate that a combination of these measures cannot be used to advantage.

[0095] Unless otherwise explicitly stated as incompatible, or the physics or otherwise of the embodiments, example or claims prevent such a combination, the features of the foregoing embodiments and examples, and of the following claims may be integrated together in any suitable arrangement, especially ones where there is a beneficial effect in doing so. This is not limited to only any specified benefit, and instead may arise from an "ex post facto" benefit. This is to say that the combination of features is not limited by the described forms, particularly the form (e.g. numbering) of the example(s), embodiment(s), or dependency of the claim(s). Moreover, this also applies to the phrase "in one embodiment", "according to an embodiment" and the like, which are merely a stylistic form of wording and are not to be construed as limiting the following features to a separate embodiment to all other instances of the same or similar wording. This is to say, a reference to 'an', 'one' or 'some' embodiment(s) may be a reference to any one or more, and/or all embodiments, or combination(s) thereof, disclosed. Also, similarly, the reference to "the" embodiment may not be limited to the immediately preceding embodiment.

[0096] The foregoing description of one or more implementations provides illustration and description, but is not intended to be exhaustive or to limit the scope of the invention to the precise form disclosed. Modifications and variations are possible in light of the above teachings or may be acquired from practice of various implementations of the present disclosure, as long as they fall within the scope of the appended claims.

[0097] The features disclosed in the foregoing description, or in the following claims, or in the accompanying drawings, expressed in their specific forms or in terms of

a means for performing the disclosed function, or a method or process for obtaining the disclosed results, as appropriate, may, separately, or in any combination of such features, be utilised for realising the invention in diverse forms thereof.

[0098] The exemplary embodiments of the invention set forth above are considered to be illustrative and not limiting.

[0099] For the avoidance of any doubt, any theoretical explanations provided herein are provided for the purposes of improving the understanding of a reader. The inventors do not wish to be bound by any of these theoretical explanations.

[0100] Any section headings used herein are for organizational purposes only and are not to be construed as limiting the subject matter described.

[0101] Throughout this specification, including the claims which follow, unless the context requires otherwise, the word "comprise" and "include", and variations such as "comprises", "comprising", and "including" will be understood to imply the inclusion of a stated integer or step or group of integers or steps but not the exclusion of any other integer or step or group of integers or steps.

[0102] It must be noted that, as used in the specification and the appended claims, the singular forms "a," "an," and "the" include plural referents unless the context clearly dictates otherwise. Ranges may be expressed herein as from "about" one particular value, and/or to "about" another particular value. When such a range is expressed, another embodiment includes from the one particular value and/or to the other particular value. Similarly, when values are expressed as approximations, by the use of the antecedent "about," it will be understood that the particular value forms another embodiment. The term "about" in relation to a numerical value is optional and means for example +/- 10%.

References

[0103] **2** Vehicle door
4 Loudspeaker system

6 Loudspeaker enclosure

50 Back face
52 Front face
54 Side face

8 Loudspeaker

10 Diaphragm **16** Surround
12 Magnet and voice coil assembly

18 Magnet assembly

20 Permanent magnet
22 Pole piece

24 Voice coil assembly

14 Basket

26 Diaphragm support
28 Magnet and voice coil assembly support

44 Exterior face
46 Interior face

30 Collapsible member(s)
34 Collapsible portion
36 Opening

38 First portion
40 Second portion
42 Apex
48 Third portion

60 Mounting member

60a Flange
62 Collar

64 Removable attachment

66 First hole
68 Second hole
70 Connector

32 Axis

Claims

1. A loudspeaker system (4) comprising:

a loudspeaker assembly (8) including a diaphragm (10), a magnet assembly (18), and a voice coil assembly (24), wherein the magnet assembly (18) and voice coil assembly (24) are driveably coupled to the diaphragm (10) to displace the diaphragm (10) to transmit pressure waves as audible sound;
an enclosure (6) arranged to enclose the loudspeaker assembly (4) and including a back face (50) and a front face (52);
wherein said back face (50) extends over the magnet assembly (18), and the magnet assembly (18) is mechanically coupled to the back face (50) and/or a side face (54) of the enclosure (6) and the diaphragm (10) is coupled to a front face (52) of the enclosure (6);
wherein the magnet assembly (18) and diaphragm (10) are directly connected to each other by a collapsible basket (14);
wherein the mechanical coupling between the magnet assembly (18) and the back face (50)

- and/or side face (54) of the enclosure (6) provides a rigid attachment between the magnet assembly (18) and the enclosure (6) such that the magnet assembly (18) remains attached to and/or retained within the enclosure (6) in the event of a load being applied to the loudspeaker system (4) which causes the loudspeaker system (4) to collapse; **characterized in that** when subject to a compressive force between the back and front face, the loudspeaker system (4) is configured to collapse at substantially the failure load of the enclosure (6), wherein said collapsing includes reduction in a distance between the magnet assembly (18) and diaphragm (10).
2. The loudspeaker system (4) of claim 1, wherein the front face (52) of the enclosure (6) comprises an aperture corresponding to the diaphragm (10) for transmission of the audible sound to a user.
 3. The loudspeaker system (4) of any preceding claim, wherein the mechanical coupling between the magnet assembly (18) and the back face (50) and/or side face (54) of the enclosure (6) is provided by one or more physical connectors, wherein the/each physical connector engages with both the magnet assembly (18) and the enclosure (6).
 4. The loudspeaker system (4) of any preceding claim, wherein the mechanical coupling between the magnet assembly (18) and the back face (50) and/or side face (54) of the enclosure (6) is provided by a physical element configured to retain the magnet assembly (18) in position with respect to the back face (50) and/or side face (54) of the enclosure (6), wherein the flange (60a) is rigidly coupled to the enclosure (6).
 5. The loudspeaker system (4) of any preceding claim, wherein the loudspeaker system (4) is configured to collapse between a range extending from the failure load of the enclosure (6) to less than 30% or 20% more than said failure load of the enclosure (6).
 6. The loudspeaker system (4) of any preceding claim, wherein, when subject to a compressive force between the back and front face, the loudspeaker system (4) is configured to collapse at
 - a failure load that is less than 5000 N or 3000 N or 2000 N or 1000 N; and/or
 - a failure load that is greater than 500 N.
 7. The loudspeaker system (4) of any preceding claim, wherein the loudspeaker assembly (8) comprising a basket (14), wherein the basket (14) is configured to collapse at less than the failure load of the enclosure (6).
 8. The loudspeaker system (4) of claim 7, wherein the collapsible basket (14) is configured to collapse at
 - less than 30% or 20% of the failure load of the enclosure (6); and/or
 - a failure load that is less than 500 N; and/or
 - a failure load that is greater than 100 N.
 9. The loudspeaker system (4) of any preceding claim, wherein the loudspeaker assembly (8) comprises a basket (14), the basket (14) including a plurality of axially extending members interconnecting a diaphragm support and the magnet assembly support, said members comprising a weakening section configured to collapse under a compressive load applied between the diaphragm support and a magnet assembly support.
 10. The loudspeaker system (4) of any of claims 1 to 9, wherein the loudspeaker assembly (8) comprising a basket (14), the basket (14) includes a plurality of axially extending members interconnecting a diaphragm support and a magnet assembly support, said members removably attached to the diaphragm support and the magnet assembly support.
 11. The loudspeaker system (4) of any preceding claim, wherein the enclosure (6) comprises a walled structure interconnecting the back face (50) and front face (52).
 12. The loudspeaker system (4) of any preceding claim, wherein the loudspeaker enclosure (6) encloses a volume of 3 litres or more.
 13. The loudspeaker system (4) of any preceding claim, wherein:
 - the loudspeaker enclosure (6) is configured to be mounted in a motorized passenger vehicle; and/or
 - the loudspeaker system (4) is arranged in a door or an undercarriage of said vehicle; and/or
 - the loudspeaker system (4) is used for a motorized passenger vehicle.
 14. A method of assembling a loudspeaker system (4) according to any previous claim, the method comprising:
 - arranging a diaphragm (10), a magnet assembly (18) of a loudspeaker assembly (8) within a loudspeaker enclosure (6);
 - connecting the diaphragm (10) to a front face (52) of the enclosure (6);
 - connecting the magnet assembly (18) to a back and/or side face of the enclosure (6), wherein a back face (50) extends over the magnet assembly

bly (18),
wherein the magnet assembly (18) and diaphragm (10) are directly connected to each other by a collapsible basket (14).

15. The method of claim 14, wherein the basket (14) including removable members to interconnect the diaphragm (10) and magnet assembly (18), the method comprising, subsequent to connection of the loudspeaker assembly (8) to the enclosure (6), removing the removable members.

Patentansprüche

1. Lautsprechersystem (4), Folgendes umfassend:

eine Lautsprecheranordnung (8), umfassend eine Membran (10), eine Magnetanordnung (18) und eine Schwingspulenordnung (24), wobei die Magnetanordnung (18) und die Schwingspulenordnung (24) ansteuerbar mit der Membran (10) gekoppelt sind, um die Membran (10) zu verschieben, um Druckwellen als hörbaren Schall auszusenden;

eine Einhausung (6), die angeordnet ist, um die Lautsprecheranordnung (4) einzuhausen, und die eine Rückseitenfläche (50) und eine Vorderseitenfläche (52) umfasst;

wobei die Rückseitenfläche (50) sich über die Magnetanordnung (18) erstreckt und die Magnetanordnung (18) mechanisch mit der Rückseitenfläche (50) und/oder einer Seitenfläche (54) der Einhausung (6) gekoppelt ist und die Membran (10) mit einer Vorderseitenfläche (52) der Einhausung (6) gekoppelt ist;

wobei die Magnetanordnung (18) und die Membran (10) über einen zusammenklappbaren Korb (14) direkt miteinander verbunden sind;

wobei die mechanische Kopplung zwischen der Magnetanordnung (18) und der Rückseitenfläche (50) und/oder Seitenfläche (54) der Einhausung (6) eine starre Befestigung zwischen der Magnetanordnung (18) und der Einhausung (6) bereitstellt, so dass die Magnetanordnung (18) auf der Einhausung (6) befestigt bleibt und/oder innerhalb dieser zurückgehalten wird, wenn eine Last auf das Lautsprechersystem (4) beaufschlagt wird, die bewirkt, dass das Lautsprechersystem (4) zusammenklappt;

dadurch gekennzeichnet, dass

das Lautsprechersystem (4), wenn es einer Druckkraft zwischen der Rück- und der Vorderseitenfläche ausgesetzt ist, dazu ausgelegt ist, um im Wesentlichen bei der Bruchlast der Einhausung (6) zusammenzuklappen, wobei das Zusammenklappen die Verringerung eines Abstandes zwischen der Magnetanordnung (18)

und der Membran (10) umfasst.

2. Lautsprechersystem (4) nach Anspruch 1, wobei die Vorderseitenfläche (52) der Einhausung (6) eine der Membran (10) entsprechende Öffnung zur Aussendung des hörbaren Schalls für einen Benutzer umfasst.
3. Lautsprechersystem (4) nach einem der vorangehenden Ansprüche, wobei die mechanische Kopplung zwischen der Magnetanordnung (18) und der Rückseitenfläche (50) und/oder Seitenfläche (54) der Einhausung (6) durch einen oder mehrere physische Verbindungselemente bereitgestellt ist, wobei das/jedes physische Verbindungselement sowohl mit der Magnetanordnung (18) als auch mit der Einhausung (6) in Eingriff steht.
4. Lautsprechersystem (4) nach einem der vorangehenden Ansprüche, wobei die mechanische Kopplung zwischen der Magnetanordnung (18) und der Rückseitenfläche (50) und/oder Seitenfläche (54) der Einhausung (6) durch ein physisches Element bereitgestellt ist, das dazu ausgelegt ist, die Magnetanordnung (18) in Bezug auf die Rückseitenfläche (50) und/oder Seitenfläche (54) der Einhausung (6) an ihrer Stelle zu halten, wobei der Flansch (60a) starr mit der Einhausung (6) gekoppelt ist.
5. Lautsprechersystem (4) nach einem der vorangehenden Ansprüche, wobei das Lautsprechersystem (4) dazu ausgelegt ist, in einem Ausmaß zusammenzuklappen, das sich von der Bruchlast der Einhausung (6) bis zu weniger als 30 % oder 20 % mehr als die Bruchlast der Einhausung (6) erstreckt.
6. Lautsprechersystem (4) nach einem der vorangehenden Ansprüche, wobei, wenn das Lautsprechersystem (4) einer Druckkraft zwischen der Vorder- und der Rückseitenfläche ausgesetzt ist, dazu ausgelegt ist, bei einer Bruchlast,
die kleiner ist als 5000 N oder 3000 N oder 2000 N oder 1000 N; und/oder
die größer ist als 500 N zusammenzuklappen.
7. Lautsprechersystem (4) nach einem der vorangehenden Ansprüche, wobei die Lautsprecheranordnung (8) einen Korb (14) umfasst, wobei der Korb (14) dazu ausgelegt ist, bei weniger als der Bruchlast der Einhausung (6) zusammenzuklappen.
8. Lautsprechersystem (4) nach Anspruch 7, wobei der zusammenklappbare Korb (14) dazu ausgelegt ist,
bei weniger als 30 % oder 20 % der Bruchlast der Einhausung (6); und/oder
bei einer Bruchlast von kleiner als 500 N;

- und/oder
bei einer Bruchlast von größer als 100 N zusammenzuklappen.
9. Lautsprechersystem (4) nach einem der vorangegangenen Ansprüche, wobei die Lautsprecheranordnung (8) einen Korb (14) umfasst, wobei der Korb (14) eine Vielzahl von sich axial erstreckenden Elementen umfasst, die eine Membranhalterung und eine Magnetanordnungshalterung miteinander verbinden, wobei die Elemente einen nachgiebigen Abschnitt umfassen, der dazu ausgelegt ist, unter einer Druckkraft, die zwischen der Membranhalterung und der Magnetanordnungshalterung beaufschlagt wird, zusammenzuklappen. 5
10. Lautsprechersystem (4) nach einem der Ansprüche 1 bis 9, wobei die Lautsprecheranordnung (8) einen Korb (14) umfasst, wobei der Korb (14) eine Vielzahl von sich axial erstreckenden Elementen umfasst, die eine Membranhalterung und eine Magnetanordnungshalterung miteinander verbinden, wobei die Elemente lösbar auf der Membranhalterung und der Magnetanordnungshalterung befestigt sind. 10
11. Lautsprechersystem (4) nach einem der vorangegangenen Ansprüche, wobei die Einhausung (6) eine Wandstruktur umfasst, die die Rückseitenfläche (50) und die Vorderseitenfläche (52) miteinander verbindet. 15
12. Lautsprechersystem (4) nach einem der vorangegangenen Ansprüche, wobei die Lautsprechereinhausung (6) ein Volumen von 3 l oder mehr einhaust. 20
13. Lautsprechersystem (4) nach einem der vorangegangenen Ansprüche, wobei:
die Lautsprechereinhausung (6) dazu ausgelegt ist, in einem motorisierten Personenzug montiert zu sein; und/oder
das Lautsprechersystem (4) in einer Tür oder einem Fahrwerk des Fahrzeugs angeordnet ist; und/oder
das Lautsprechersystem (4) für ein motorisiertes Personenzug verwendet wird. 25
14. Verfahren zum Zusammenbau eines Lautsprechersystems (4) nach einem der vorangegangenen Ansprüche, wobei das Verfahren Folgendes umfasst: 30
- Anordnen einer Membran (10), einer Magnetanordnung (18) einer Lautsprecheranordnung (8) innerhalb einer Lautsprechereinhausung (6);
Verbinden der Membran (10) mit einer Vorderseitenfläche (52) der Einhausung (6);
Verbinden der Magnetanordnung (18) mit einer Rückseiten- und/oder einer Seitenfläche der 35

Einhausung (6), wobei sich eine Rückseitenfläche (50) über die Magnetanordnung (18) erstreckt,
wobei die Magnetanordnung (18) und die Membran (10) durch einen zusammenklappbaren Korb (14) direkt miteinander verbunden sind. 40

15. Verfahren nach Anspruch 14, wobei der Korb (14) entfernbare Elemente zum Verbinden der Membran (10) und der Magnetanordnung (18) umfasst, wobei das Verfahren nach dem Verbinden der Lautsprecheranordnung (8) mit der Einhausung (6) das Entfernen der entfernbaren Elemente umfasst. 45

Revendications

1. Système de haut-parleur (4), comprenant :

un ensemble haut-parleur (8) comprenant un diaphragme (10), un ensemble aimant (18) et un ensemble bobine acoustique (24), dans lequel l'ensemble aimant (18) et l'ensemble bobine acoustique (24) sont couplés de manière entraînée au diaphragme (10) pour déplacer le diaphragme (10) afin de transmettre des ondes de pression sous forme de son audible ;
une enceinte (6) agencée pour enfermer l'ensemble haut-parleur (4) et incluant une face arrière (50) et une face avant (52) ;
dans lequel ladite face arrière (50) s'étend sur l'ensemble aimant (18), et l'ensemble aimant (18) est couplé mécaniquement à la face arrière (50) et/ou à une face latérale (54) de l'enceinte (6) et le diaphragme (10) est couplé à une face avant (52) de l'enceinte (6) ;
dans lequel l'ensemble aimant (18) et le diaphragme (10) sont directement reliés l'un à l'autre par un panier pliable (14) ;
dans lequel le couplage mécanique entre l'ensemble aimant (18) et la face arrière (50) et/ou la face latérale (54) de l'enceinte (6) fournit une fixation rigide entre l'ensemble aimant (18) et l'enceinte (6) de sorte que l'ensemble aimant (18) reste fixé et/ou retenu à l'intérieur de l'enceinte (6) dans le cas où une charge est appliquée au système de haut-parleur (4) qui provoque un affaissement du système de haut-parleur (4) ; **caractérisé en ce que**
lorsqu'il est soumis à une force de compression entre la face arrière et la face avant, le système de haut-parleur (4) est configuré pour s'affaisser sensiblement à la charge de défaillance de l'enceinte (6), dans lequel ledit affaissement inclut une réduction d'une distance entre l'ensemble aimant (18) et le diaphragme (10). 50

2. Système de haut-parleur (4) selon la revendication

- 1, dans lequel la face avant (52) de l'enceinte (6) comprend une ouverture correspondant au diaphragme (10) pour la transmission du son audible à un utilisateur.
3. Système de haut-parleur (4) selon l'une quelconque des revendications précédentes, dans lequel le couplage mécanique entre l'ensemble aimant (18) et de la face arrière (50) et/ou la face latérale (54) de l'enceinte (6) est fourni par un ou plusieurs connecteurs physiques, dans lequel le/chaque connecteur physique vient en prise à la fois avec l'ensemble aimant (18) et l'enceinte (6).
4. Système de haut-parleur (4) selon l'une quelconque des revendications précédentes, dans lequel le couplage mécanique entre l'ensemble aimant (18) et la face arrière (50) et/ou la face latérale (54) de l'enceinte (6) est fourni par un élément physique configuré pour retenir l'ensemble aimant (18) en position par rapport à la face arrière (50) et/ou à la face latérale (54) de l'enceinte (6), dans lequel la bride (60a) est couplée de manière rigide à l'enceinte (6).
5. Système de haut-parleur (4) selon l'une quelconque des revendications précédentes, dans lequel le système de haut-parleur (4) est configuré pour s'affaisser entre une plage allant de la charge de défaillance de l'enceinte (6) à moins de 30 % ou 20 % de plus que ladite charge de défaillance de l'enceinte (6).
6. Système de haut-parleur (4) selon l'une quelconque des revendications précédentes, dans lequel, lorsqu'il est soumis à une force de compression entre la face arrière et la face avant, le système de haut-parleur (4) est configuré pour s'affaisser sous
- une charge de défaillance qui est inférieure à 5 000 N ou 3 000 N ou 2 000 N ou 1 000 N ; et/ou
- une charge de défaillance qui est supérieure à 500 N.
7. Système de haut-parleur (4) selon l'une quelconque des revendications précédentes, dans lequel l'ensemble haut-parleur (8) comprend un panier (14), dans lequel le panier (14) est configuré pour s'affaisser à une charge inférieure à la charge de défaillance de l'enceinte (6).
8. Système de haut-parleur (4) selon la revendication 7, dans lequel le panier pliable (14) est configuré pour s'affaisser à moins de 30 % ou 20 % de la charge de défaillance de l'enceinte (6) ; et/ou
- une charge de défaillance qui est inférieure à 500 N ; et/ou
- une charge de défaillance qui est supérieure à 100 N.
9. Système de haut-parleur (4) selon l'une quelconque des revendications précédentes, dans lequel l'ensemble haut-parleur (8) comprend un panier (14), le panier (14) incluant une pluralité d'éléments s'étendant axialement interconnectant un support de diaphragme et le support d'ensemble aimant, lesdits éléments comprenant une section d'affaiblissement configurée pour s'affaisser sous une charge de compression appliquée entre le support de diaphragme et un support d'ensemble aimant.
10. Système de haut-parleur (4) selon l'une quelconque des revendications 1 à 9, dans lequel l'ensemble haut-parleur (8) comprend un panier (14), le panier (14) inclut une pluralité d'éléments s'étendant axialement interconnectant un support de diaphragme et un support d'ensemble aimant, lesdits éléments étant fixés de manière amovible au support de diaphragme et au support d'ensemble aimant.
11. Système de haut-parleur (4) selon l'une quelconque des revendications précédentes, dans lequel l'enceinte (6) comprend une structure à paroi interconnectant la face arrière (50) et la face avant (52).
12. Système de haut-parleur (4) selon l'une quelconque des revendications précédentes, dans lequel l'enceinte de haut-parleur (6) renferme un volume de 3 litres ou plus.
13. Système de haut-parleur (4) selon l'une quelconque des revendications précédentes, dans lequel :
- l'enceinte de haut-parleur (6) est configurée pour être montée dans un véhicule de tourisme motorisé ; et/ou
- le système de haut-parleur (4) est agencé dans une porte ou un train roulant dudit véhicule ; et/ou
- le système de haut-parleur (4) est utilisé pour un véhicule de tourisme motorisé.
14. Procédé d'assemblage d'un système de haut-parleur (4) selon l'une quelconque des revendications précédentes, le procédé comprenant les étapes consistant à :
- agencer un diaphragme (10), un ensemble aimant (18) d'un ensemble haut-parleur (8) à l'intérieur d'une enceinte de haut-parleur (6) ;
- relier le diaphragme (10) à une face avant (52) de l'enceinte (6) ;
- relier l'ensemble aimant (18) à une face arrière et/ou latérale de l'enceinte (6), dans lequel une face arrière (50) s'étend sur l'ensemble aimant (18),
- dans lequel l'ensemble aimant (18) et le diaphragme (10) sont directement reliés l'un à

l'autre par un panier pliable (14).

15. Procédé selon la revendication 14, dans lequel le panier (14) inclut des éléments amovibles pour interconnecter le diaphragme (10) et l'ensemble aimant (18), le procédé comprenant, après la liaison de l'ensemble haut-parleur (8) à l'enceinte (6), le retrait des éléments amovibles.

10

15

20

25

30

35

40

45

50

55

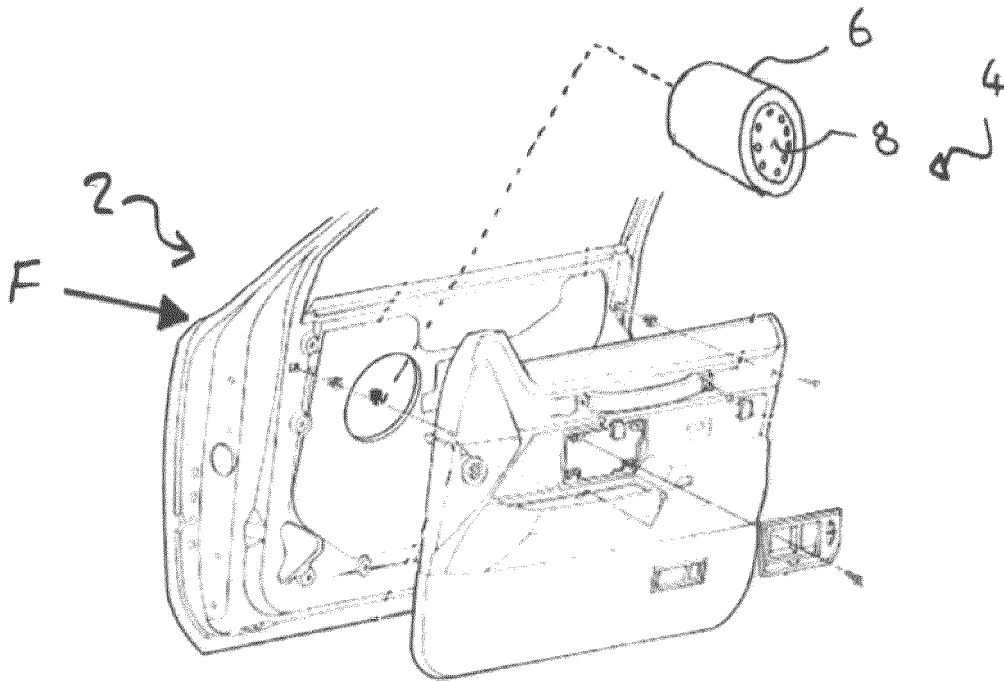

Figure 1

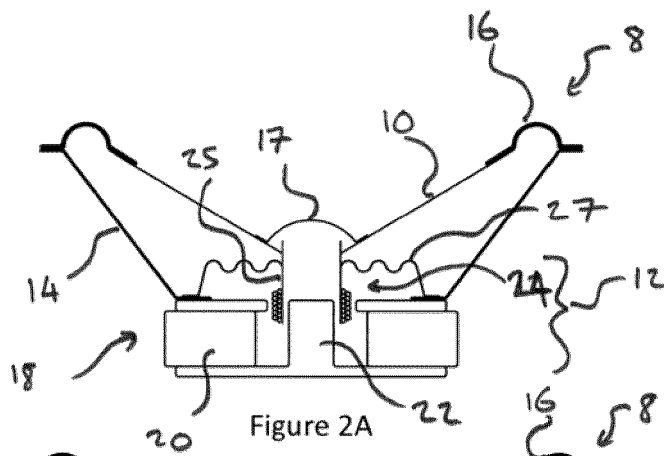

Figure 2A

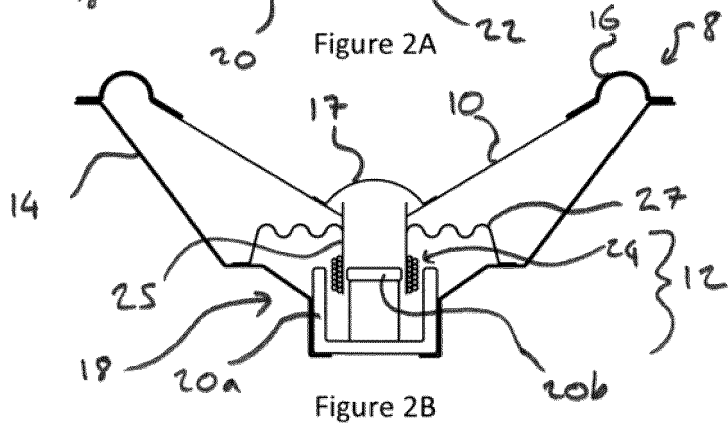

Figure 2B

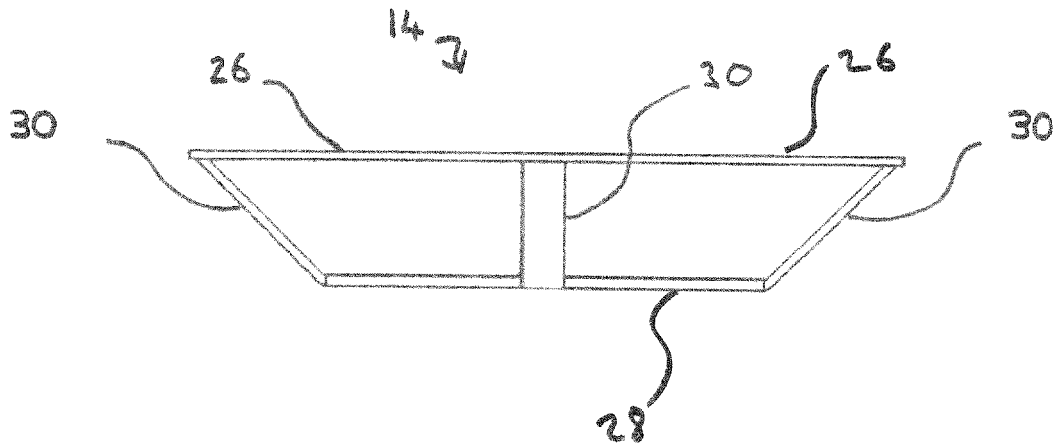

Figure 3

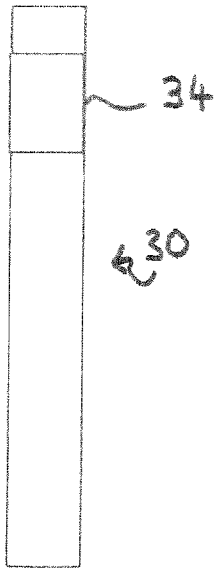

Figure 4A

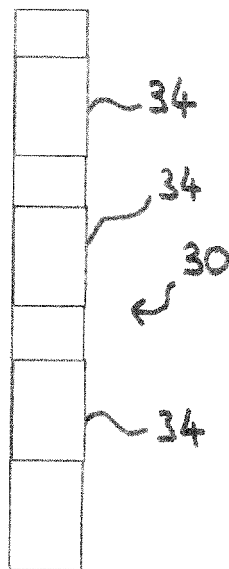

Figure 4B

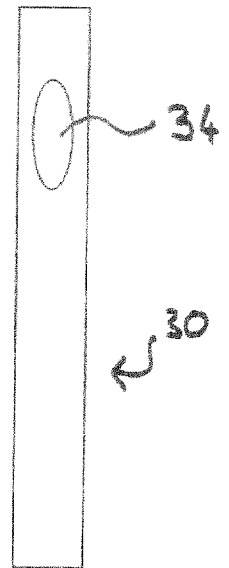

Figure 4C

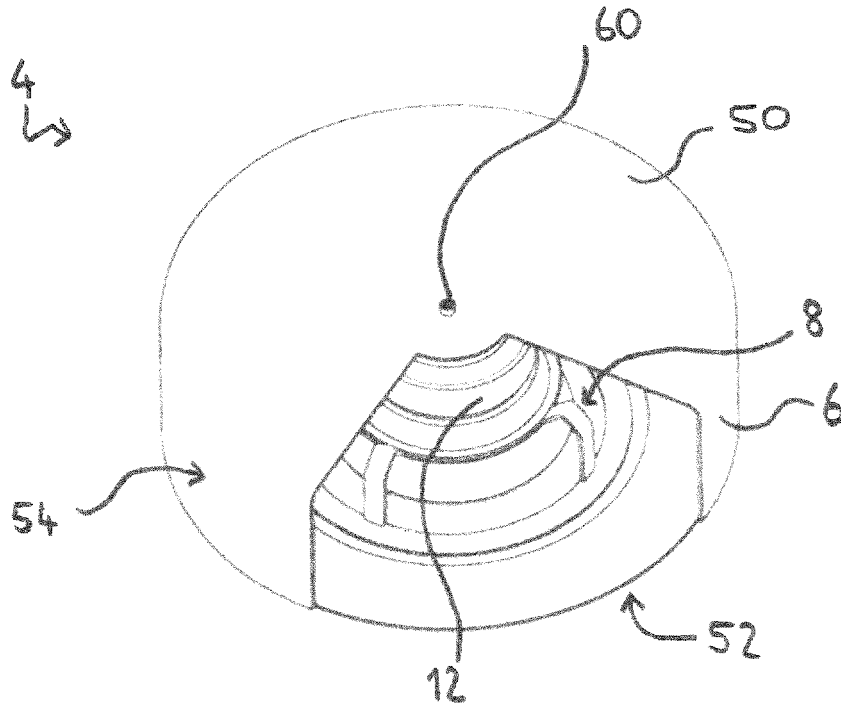

Figure 7

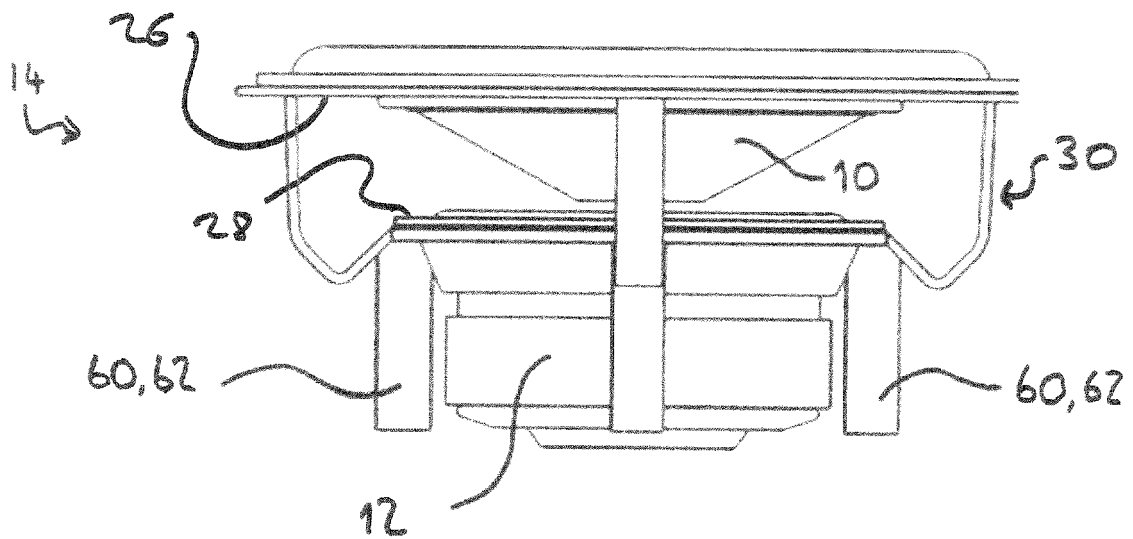
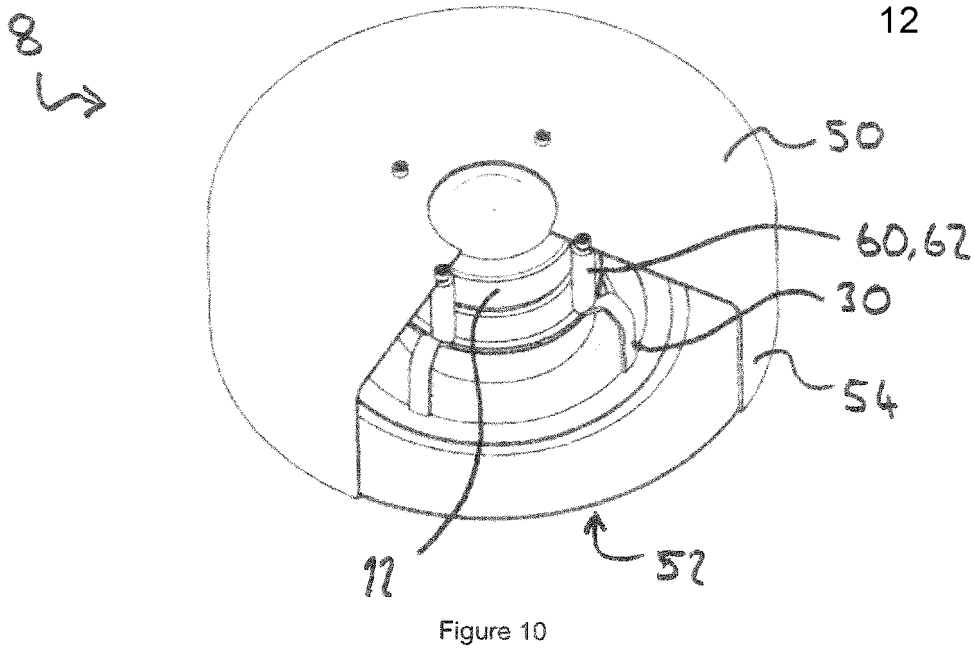
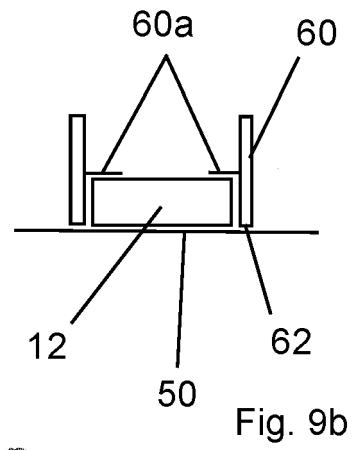
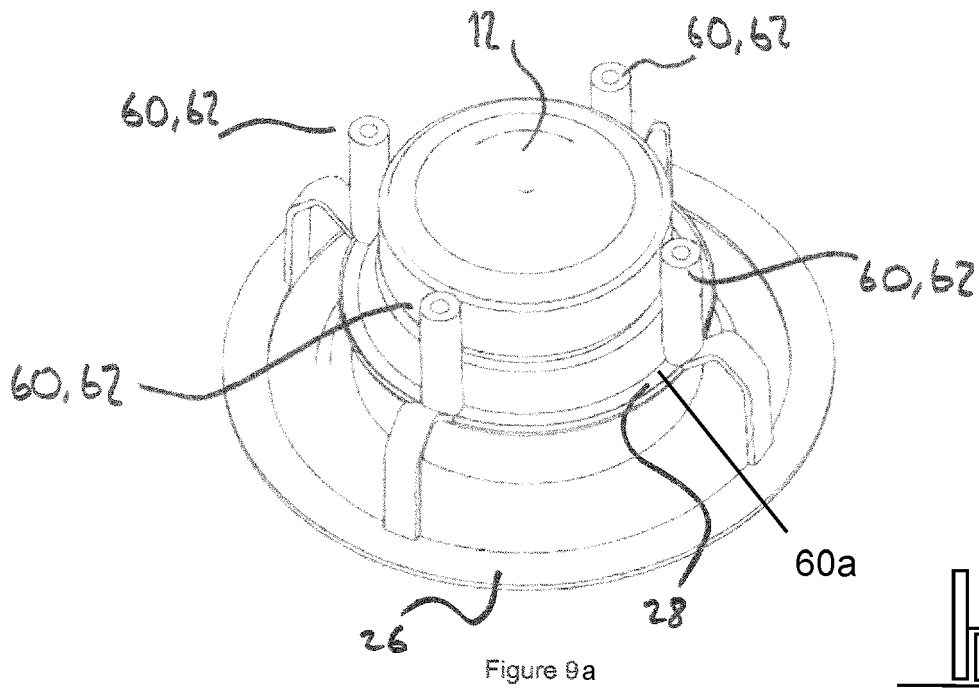

Figure 8



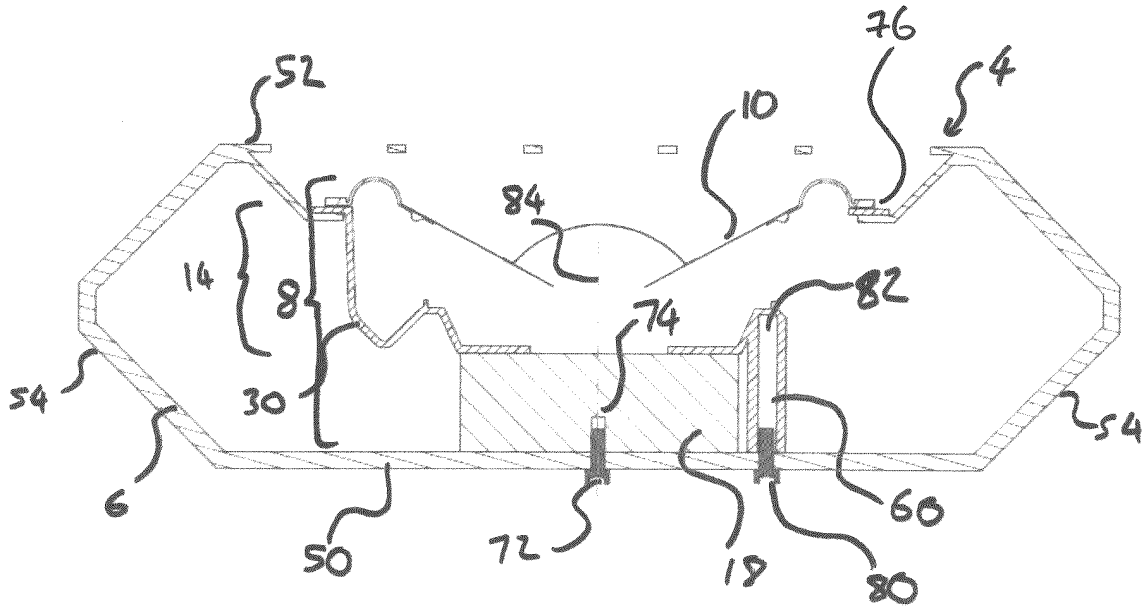

Figure 11

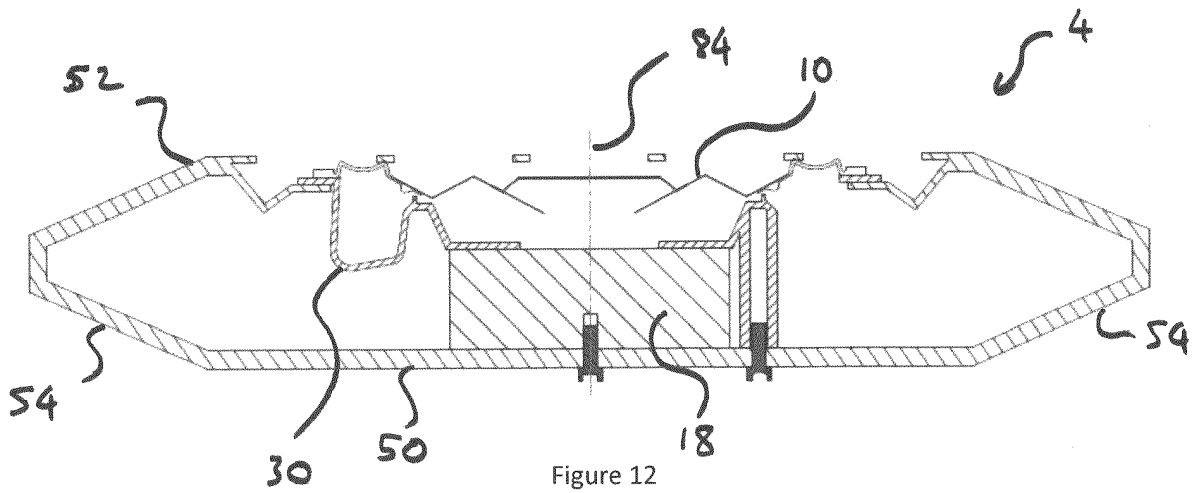

Figure 12

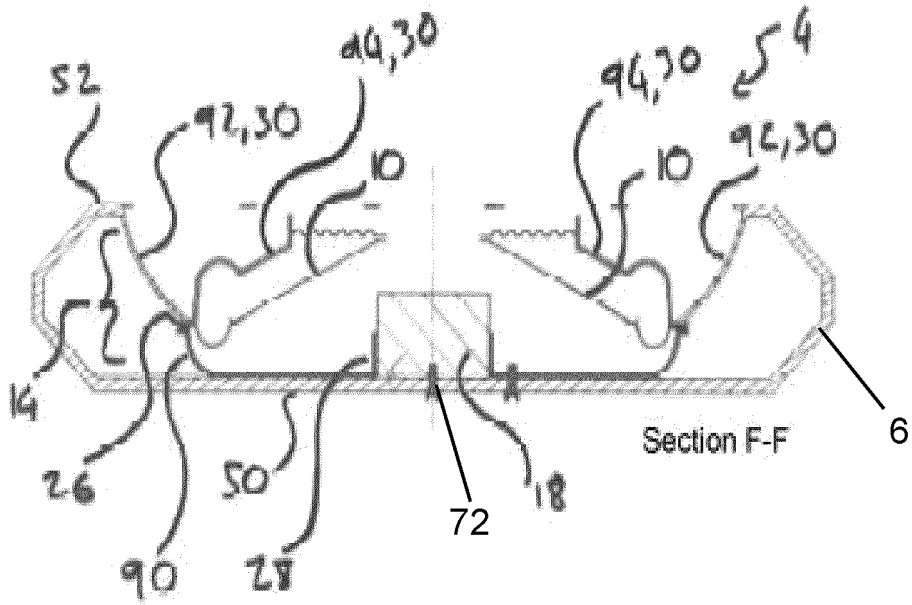

Figure 13

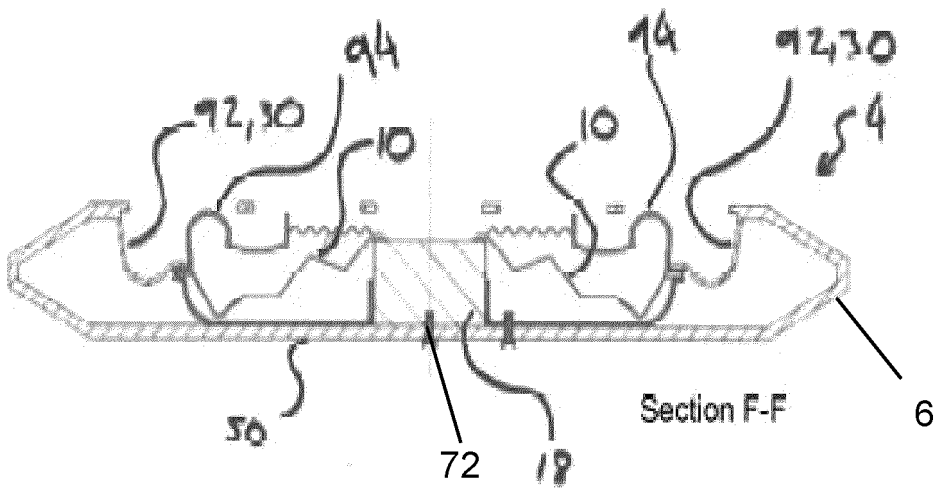

Figure 14

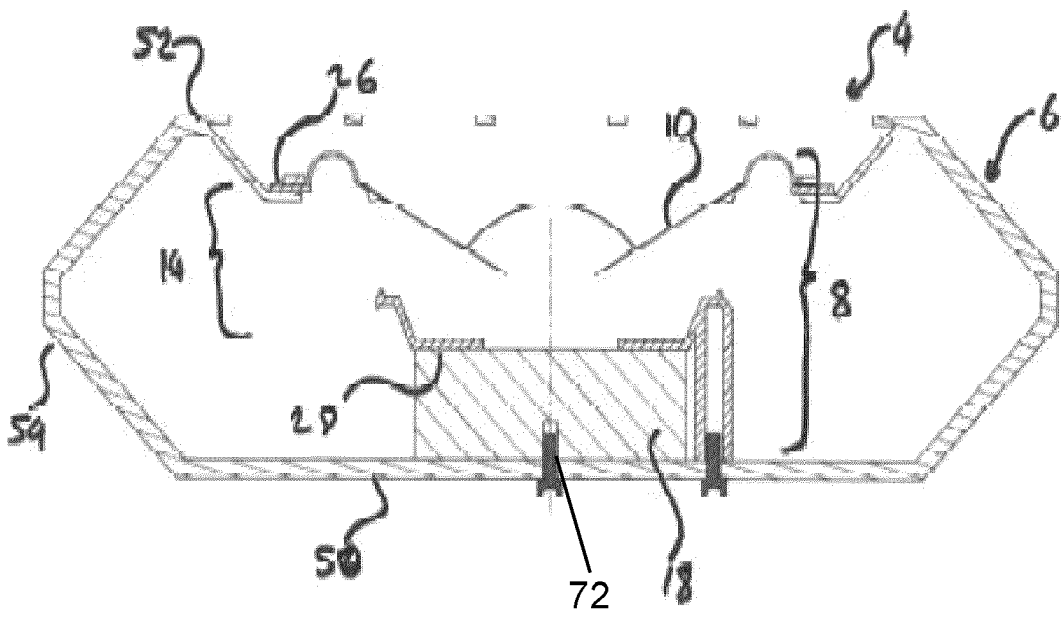

Figure 15

REFERENCES CITED IN THE DESCRIPTION

This list of references cited by the applicant is for the reader's convenience only. It does not form part of the European patent document. Even though great care has been taken in compiling the references, errors or omissions cannot be excluded and the EPO disclaims all liability in this regard.

Patent documents cited in the description

- EP 0510345 A1 [0006]
- WO 2004064448 A1 [0007]
- DE 19649140 A1 [0008]
- FR 2944753 A1 [0009]
- GB 2165419 A [0010] [0017]
- US 20040208336 A [0010] [0017]
- US 20130126263 A [0010] [0017]