



US 20190304481A1

(19) **United States**

(12) **Patent Application Publication**
Shih

(10) **Pub. No.: US 2019/0304481 A1**

(43) **Pub. Date: Oct. 3, 2019**

(54) **DYNAMIC PLAYER SELECTION FOR AUDIO SIGNAL PROCESSING**

H04R 3/00 (2006.01)

H04R 27/00 (2006.01)

G06F 3/16 (2006.01)

(71) Applicant: **SONOS, INC.**, Santa Barbara, CA (US)

(52) **U.S. Cl.**

CPC *G10L 21/0216* (2013.01); *G10L 21/0208*

(2013.01); *G10L 21/0264* (2013.01); *H04W*

24/02 (2013.01); *H04R 27/00* (2013.01);

G06F 3/162 (2013.01); *H04R 3/005* (2013.01)

(72) Inventor: **Shao-Fu Shih**, Boston, MA (US)

(21) Appl. No.: **16/444,975**

(22) Filed: **Jun. 18, 2019**

(57) **ABSTRACT**

Related U.S. Application Data

(63) Continuation of application No. 15/959,907, filed on Apr. 23, 2018, now Pat. No. 10,332,537, which is a continuation of application No. 15/178,180, filed on Jun. 9, 2016, now Pat. No. 9,978,390.

A set of signal measures is sent, wherein each signal measure in the set of signal measures corresponds to a respective audio signal received by a playback device in a media playback system and is processed based on a first set of audio processing algorithms. A plurality of signal measures is identified in the set of signal measures. Audio signals corresponding to the identified plurality of signal measures are processed by one or more devices in the media playback system to improve a signal measure of each of the audio signals. The audio signals are processed based on a second set of audio processing algorithms. The processed audio signals are combined into a combined audio signal.

Publication Classification

(51) **Int. Cl.**

G10L 21/0216 (2006.01)

G10L 21/0208 (2006.01)

G10L 21/0264 (2006.01)

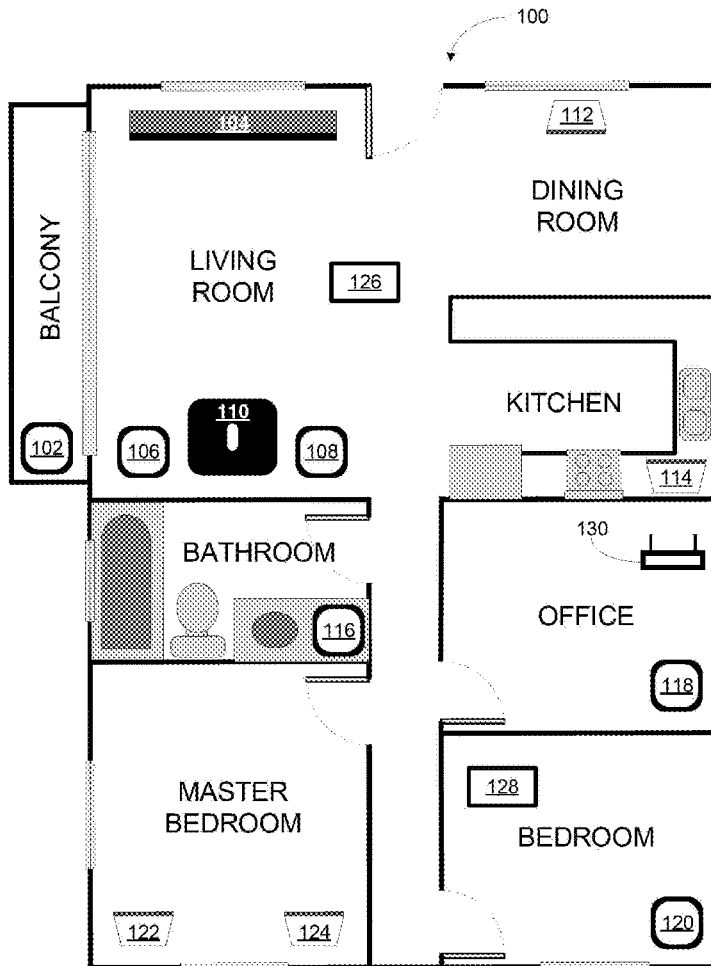

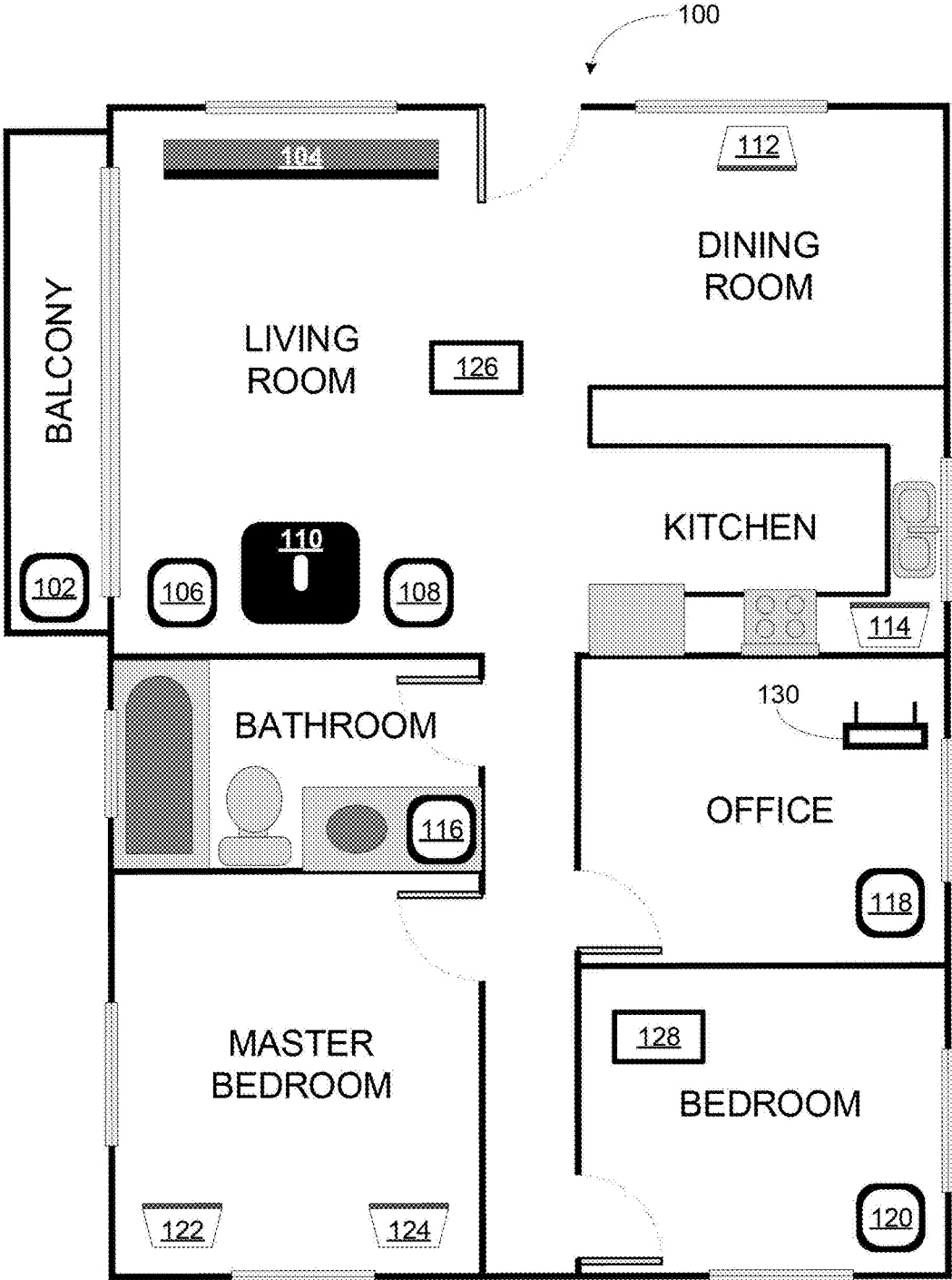

FIGURE 1

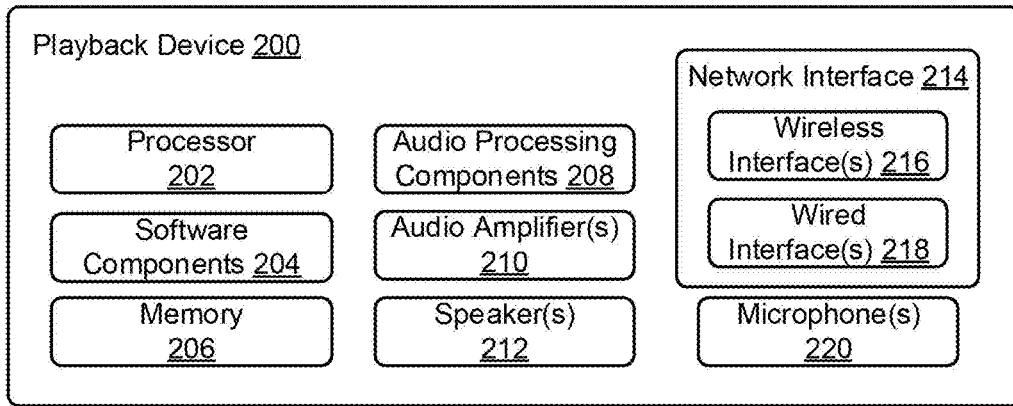

FIGURE 2

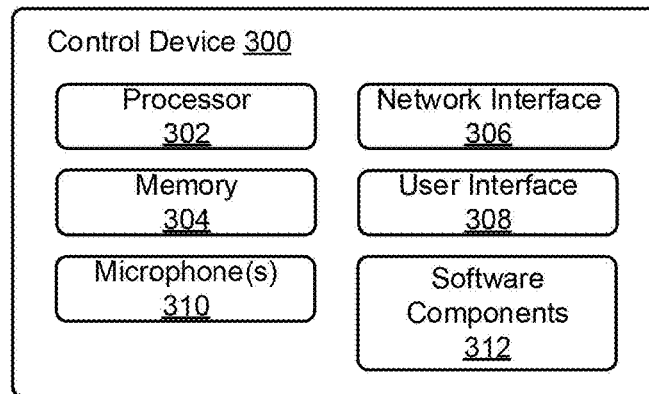

FIGURE 3

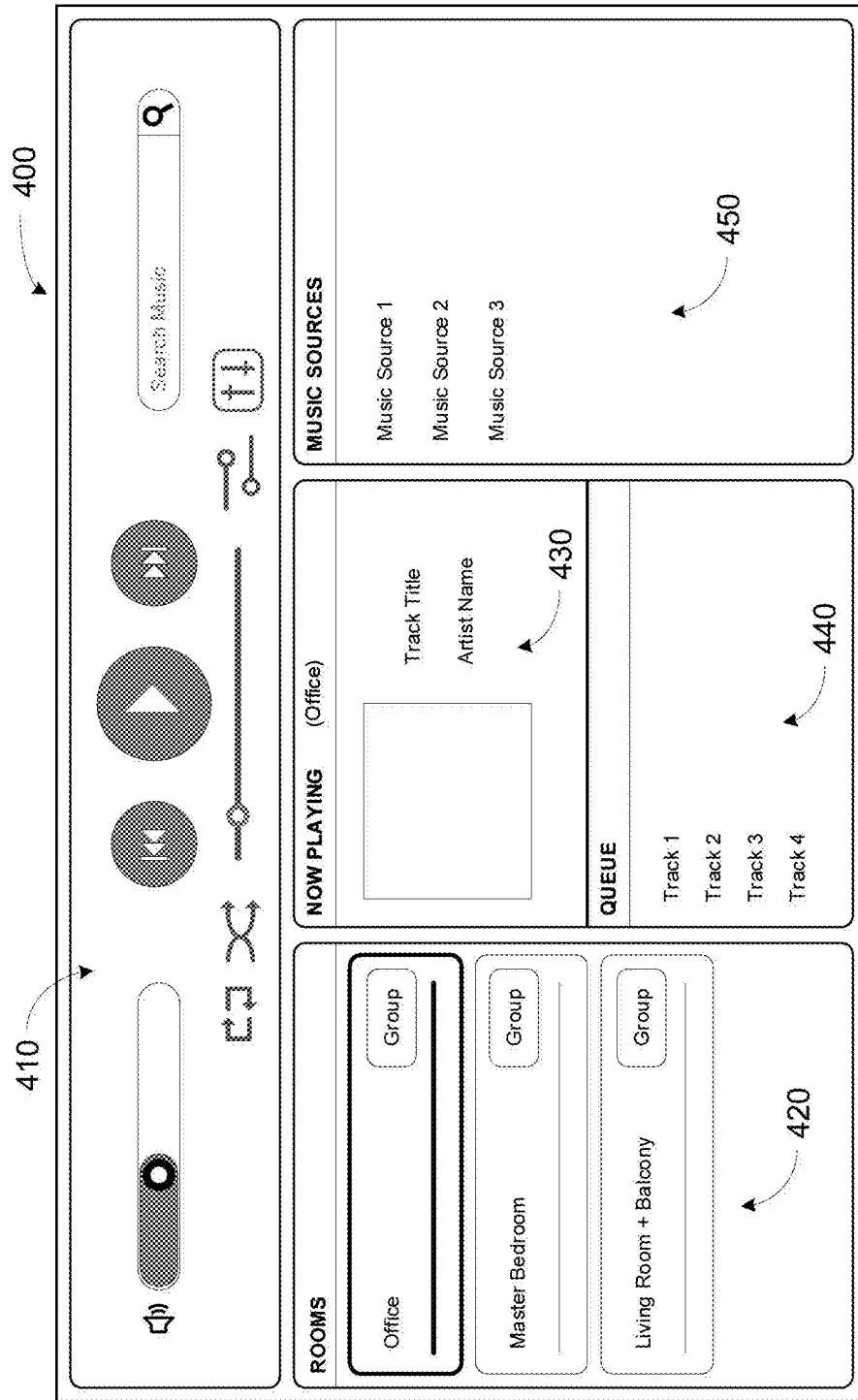

FIGURE 4

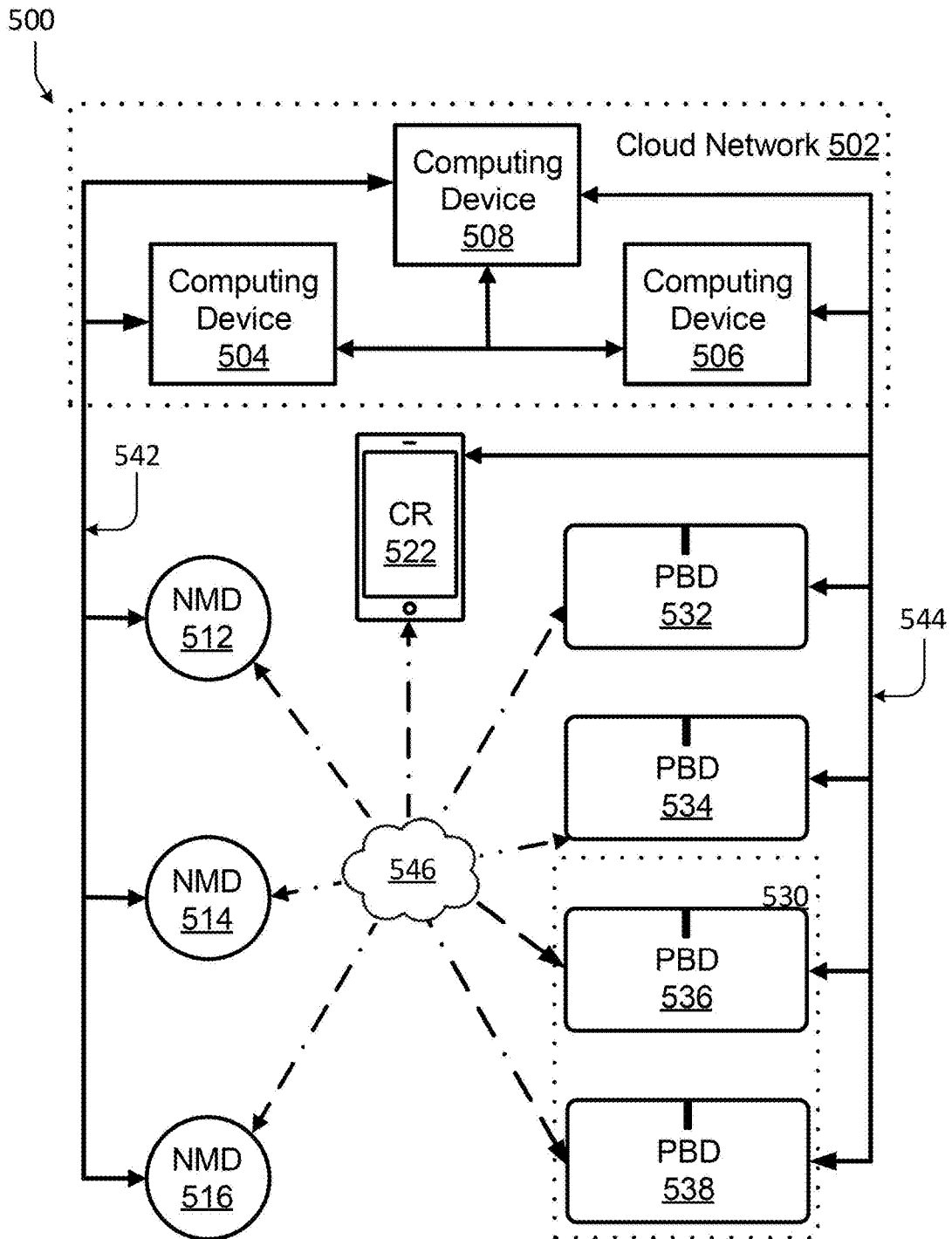

FIGURE 5

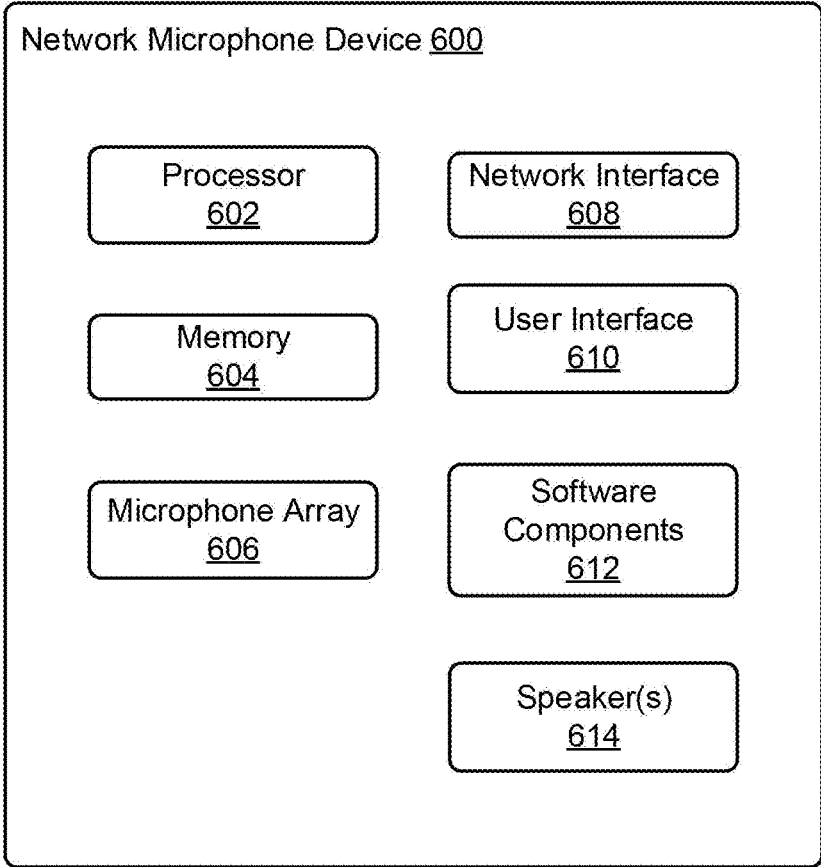

FIGURE 6

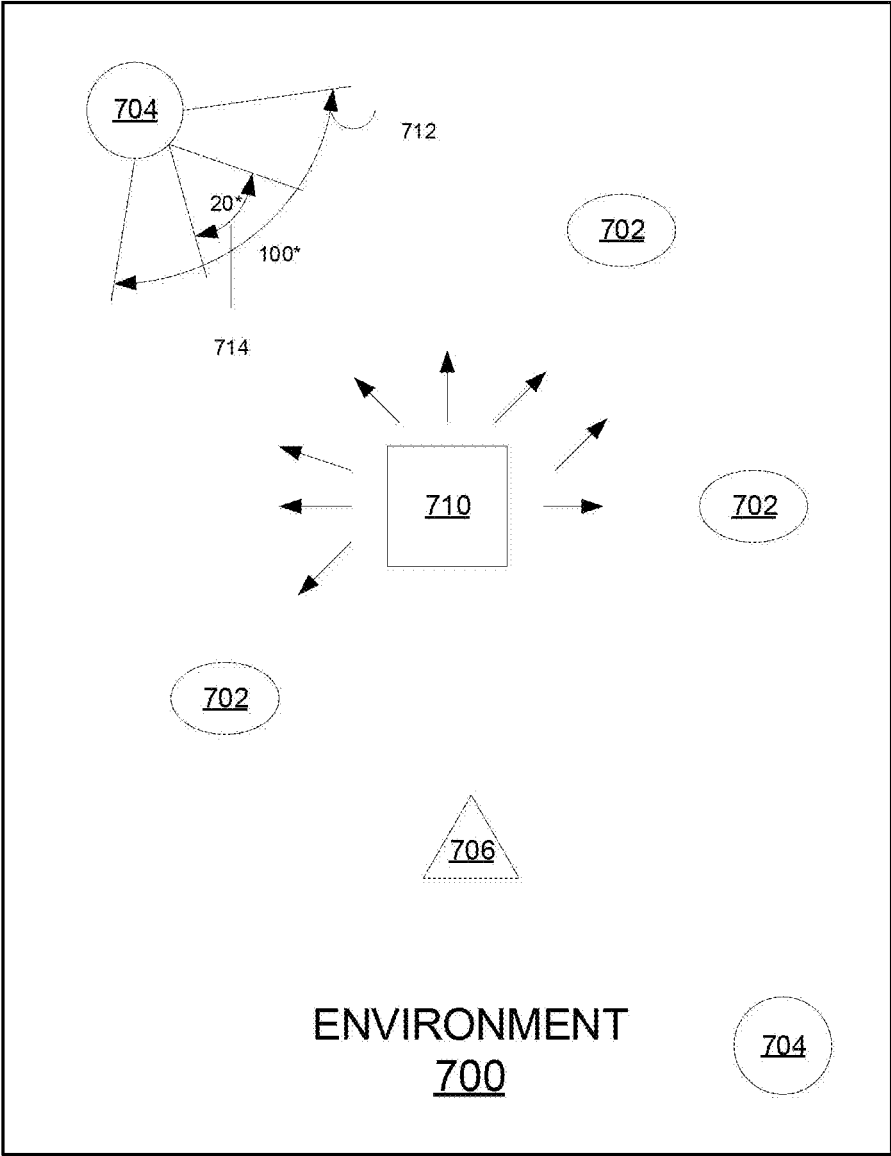

FIGURE 7

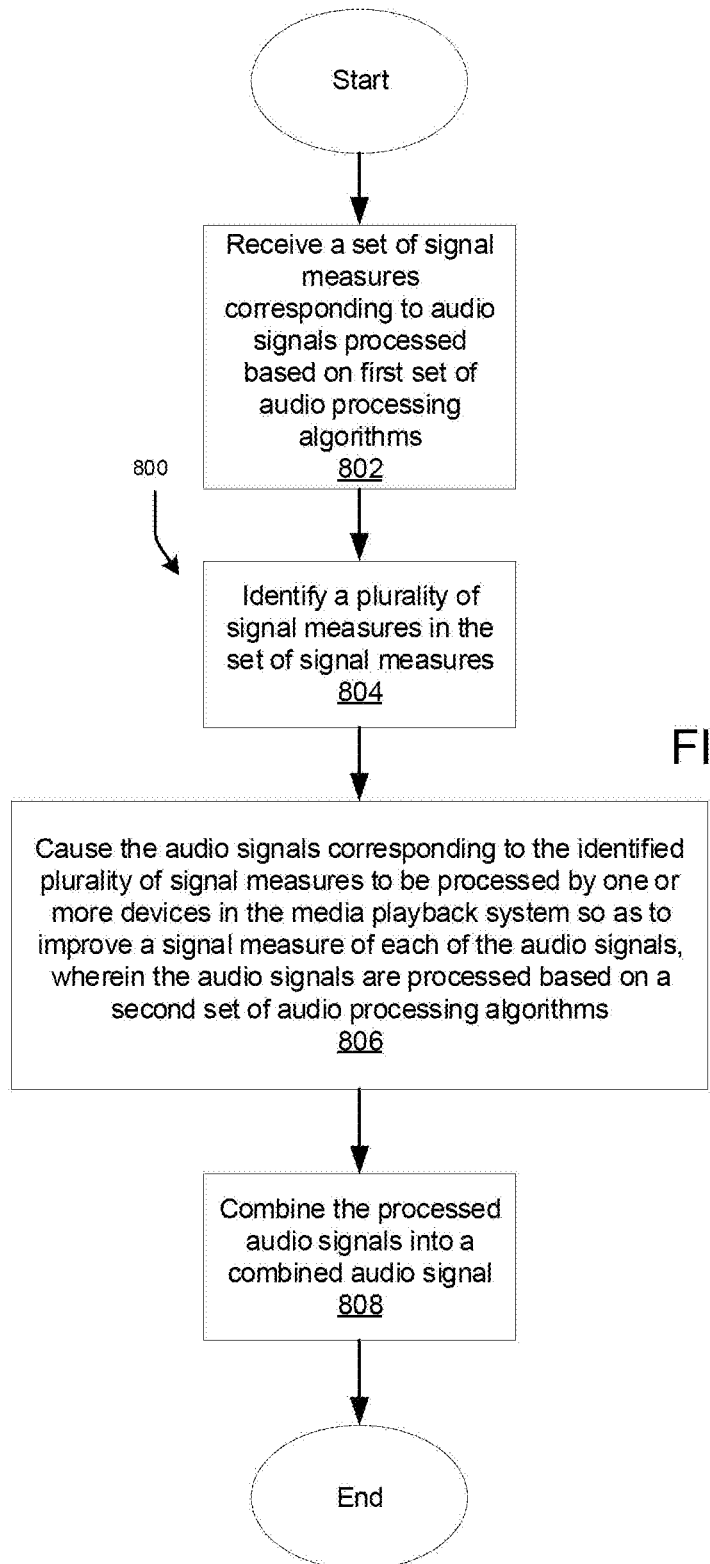

FIGURE 8

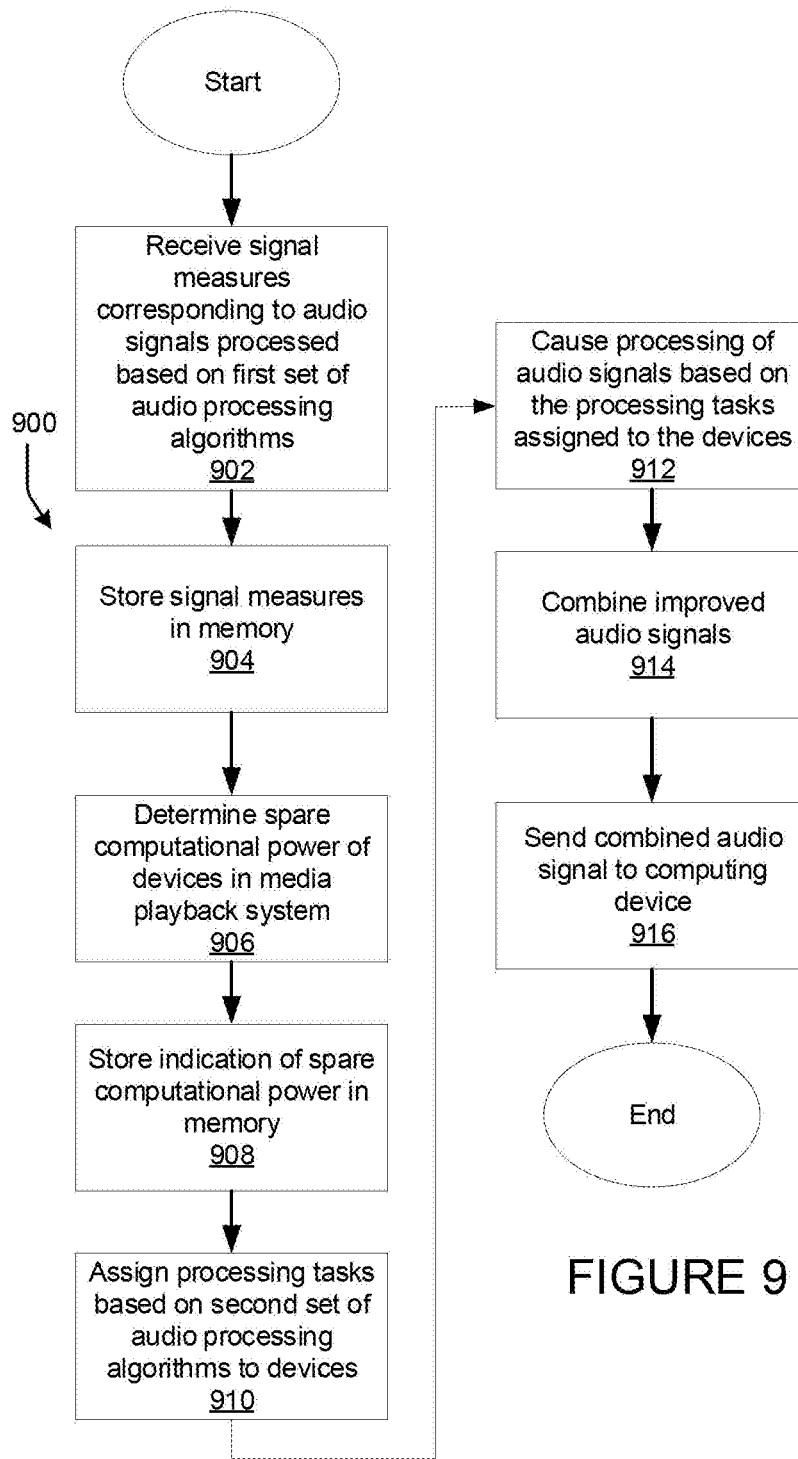

FIGURE 9

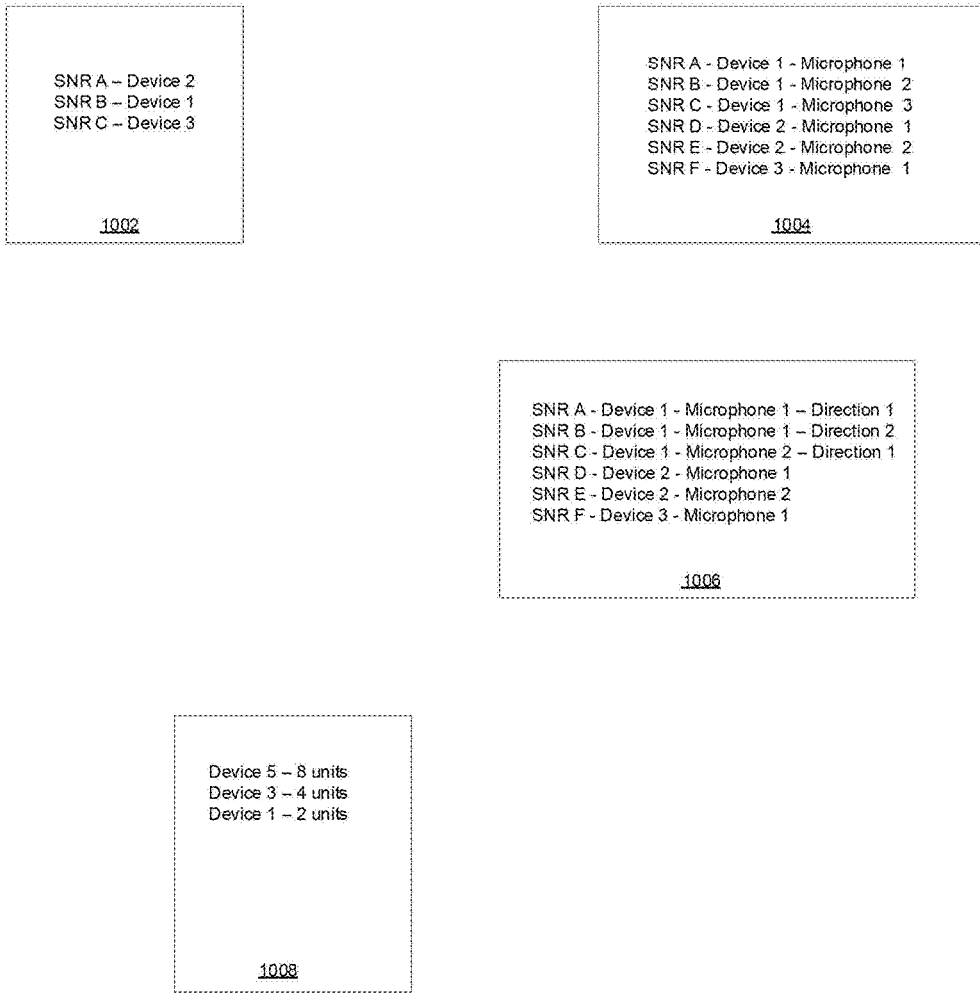

FIGURE 10

DYNAMIC PLAYER SELECTION FOR AUDIO SIGNAL PROCESSING

CROSS-REFERENCE TO RELATED APPLICATIONS

[0001] This application claims priority to, and is a continuation of, U.S. Non-Provisional patent application Ser. No. 15/959,907, filed on Apr. 23, 2018, and titled “Dynamic Player Selection for Audio Signal Processing,” which is a continuation of U.S. Non-Provisional patent application Ser. No. 15/178,180, filed on Jun. 9, 2016, and titled “Dynamic Player Selection for Audio Signal Processing”, the contents of each of which is incorporated herein in its entirety.

FIELD OF THE DISCLOSURE

[0002] The disclosure is related to consumer goods and, more particularly, to methods, systems, products, features, services, and other elements directed to media playback or some aspect thereof.

BACKGROUND

[0003] Options for accessing and listening to digital audio in an out-loud setting were limited until in 2003, when SONOS, Inc. filed for one of its first patent applications, entitled “Method for Synchronizing Audio Playback between Multiple Networked Devices,” and began offering a media playback system for sale in 2005. The Sonos Wireless HiFi System enables people to experience music from many sources via one or more networked playback devices. Through a software control application installed on a smartphone, tablet, or computer, one can play audio in any room that has a networked playback device. Additionally, using the control device, for example, different songs can be streamed to each room with a playback device, rooms can be grouped together for synchronous playback, or the same song can be heard in all rooms synchronously.

[0004] Given the ever growing interest in digital media, there continues to be a need to develop consumer-accessible technologies to further enhance the listening experience.

BRIEF DESCRIPTION OF THE DRAWINGS

[0005] Features, aspects, and advantages of the presently disclosed technology may be better understood with regard to the following description, appended claims, and accompanying drawings where:

[0006] FIG. 1 shows an example playback system configuration in which certain embodiments may be practiced;

[0007] FIG. 2 shows a functional block diagram of an example playback device;

[0008] FIG. 3 shows a functional block diagram of an example control device;

[0009] FIG. 4 shows an example control device interface;

[0010] FIG. 5 shows an example network configuration in which certain embodiments may be practiced;

[0011] FIG. 6 shows a functional block diagram of an example network microphone device;

[0012] FIG. 7 shows an example environment in which certain embodiments may be practiced;

[0013] FIG. 8 shows an example flow diagram associated with distributing processing across devices in a media playback system;

[0014] FIG. 9 shows a more detailed example flow diagram associated with distributing processing across devices in the media playback system; and

[0015] FIG. 10 shows example tables for managing signal measures of audio signals and spare computational power of devices in the media playback system.

[0016] The drawings are for the purpose of illustrating example embodiments, but it is understood that the embodiments are not limited to the arrangements and instrumentality shown in the drawings.

DETAILED DESCRIPTION

I. Overview

[0017] A media playback system may include one or more playback devices, network microphone devices, controller devices, and/or computing devices. The playback device, network microphone device, controller device, and computing device may collectively coordinate play back of audio content such as music tracks.

[0018] The playback device, the controller device, and the network microphone device may be in an environment such as a living room in a home. A microphone array of one or more of these devices may receive an audio signal. The audio signal may include a sonic input and noise. The sonic input may be a voice input such as a request to perform an action associated with the media playback system, e.g., “play audio” or “stop playing audio”. The sonic input may take the form of any other voice input as well. The noise may be any type of audio other than the sonic input. For example, the noise could include white noise or impulse noise. Alternatively, the “noise” could be audio content played by a playback device in the media playback system such as music.

[0019] It may be desirable to recover the sonic input from the audio signal. Embodiments described herein are directed to distributing, across devices in the media playback system, processing associated with improving a signal measure (e.g., signal to noise ratio) of the audio signal received by a device in the media playback system prior to the recovery of the sonic input. The processing is distributed to reduce degradation in performance of a particular device in the media playback system while the signal to noise ratio is improved. Improving the signal to noise ratio results in attenuating noise in the audio signal. The improved audio signal may then be passed to the computing device such as a server which is arranged to recover the sonic input. If the sonic input is a voice input, the server may interpret the voice input to determine the action associated with the voice input such as “play music on a playback device” or to “turn off the playback device”. The server may then cause the media playback system to perform the action.

[0020] As one example, an echo cancellation method may be used to improve the signal to noise ratio of the audio signal received by a device in the media playback system. The echo cancellation method seeks to remove echoes in the received audio signal. As another example, a beamforming method may be used to improve the signal to noise ratio of the audio signal received by a device in the media playback system. The beamforming method may determine characteristics of an audio signal received in certain direction such as whether the sonic input of the audio signal originates from the certain direction. In another example, one or more playback devices in the media playback system may be

playing audio content in the background as the sonic input is received. The media playback system may have knowledge of this audio content, e.g., the spectral content of the audio content. The knowledge of the audio playing in the background may be used to improve the signal to noise ratio of the audio signal.

[0021] The methods described above are examples of various methods of improving the signal to noise ratio which can be applied separately or together to the audio signal to improve the signal to noise ratio. In this regard, a device may apply one or more of the algorithms described above, i.e., a first set of audio processing algorithms, to improve the signal to noise ratio of an audio signal that is received by the device. In embodiments, one or more of the received audio signal and the improved audio signal may also be stored on the playback device, controller device, or computing device as audio files.

[0022] In addition to improving the signal to noise ratio of the audio signal, a signal measure, such as the signal to noise ratio, for the audio signal as improved by one of the example algorithms described above may be calculated. The signal to noise ratio may be a ratio of the improved audio signal to the received audio signal. For example, the received audio signal and the improved audio signal may be represented as impulse responses. The impulse response of the improved audio signal may be divided by the received audio signal to calculate the signal to noise ratio.

[0023] A signal to noise ratio may be associated with each microphone array. For example, the echo cancellation algorithm provides an improved audio signal based on the audio signal received by the microphone array. The signal to noise ratio is based on this improved audio signal. Further, this signal to noise ratio may be also be associated with the device of the microphone array.

[0024] Alternatively, a plurality of signal to noise ratios may be associated with the microphone array. Each direction of a plurality of directions processed by a beamforming algorithm may have an associated signal to noise ratio. For example, the audio signal may be processed at directions of 20 degree angular intervals around the microphone array. Each 20 degree angular interval (18 intervals in total over 360 degrees) may have an associated impulse response of the received audio signal, impulse response of the improved audio signal, and signal to noise ratio.

[0025] The signal to noise ratios may be stored in a table. The table may also store an indication of the device/microphone array associated with a signal to noise ratio. In the case of beamforming, the table may also store an indication of a direction associated with the signal to noise ratio. The table may also be sorted such that the first entry in the table may identify the highest signal to noise ratio for the audio signal and the last entry may identify the lowest signal to noise ratio for the audio signal.

[0026] The respective processors of devices in the media playback system may have spare computational power. The spare computational power may be that computational power beyond what may be necessary to perform certain functions of the device. For example, the playback device may use computational power to play back audio but all the computational power may not be needed to play back the audio. The remaining computational power may be considered spare and could be used for further processing of the audio signal such as improving the signal to noise ratio of the audio signal received by a device.

[0027] Each device may indicate its spare computational power to a given device, such as a playback device, controller device, or server in the media playback system. For example, the spare computational power may be indicated by a state variable of the media playback system. This state variable may be periodically updated and made available to the devices in the media playback system. In some examples, the state variable may take the form of a flag which indicates that that playback device has a spare computational power. Further, various types of flags may be set depending on an amount of spare computational power available. Based on the state variable, the given device in the media playback system may obtain the spare computational power for each device and generate a table that identifies for each device its spare processing power. The spare computational power of each device in the media playback device may be organized in a table. Further, the table may be ordered based on availability of processing power. For example, the first entry in the table may be the device with a highest spare processing power and the last entry may identify the device with a lowest spare processing power. Other arrangements are also possible.

[0028] Then, processing tasks are assigned to the devices based on its spare computational power as defined by the table and computational power required by a processing task. The processing tasks may be defined by a second set of audio processing algorithms which includes the echo cancellation method, beamforming method, and/or subtraction of known signal method, among other. Each of these methods may have a higher resolution as compared to the first set of audio processing algorithms. The higher resolution processing may result in a further improvement of the signal to noise ratio of the audio signal as compared the first set of audio processing algorithms applied by the device when the audio signal was received.

[0029] The given device may assign impulse responses of one or more of the audio signals received by the device based on the spare computational power of a device and signal to noise ratios of the impulse responses. The impulse responses processed by each device based on the second set of audio processing algorithms result in an improved audio signal with a higher signal to noise ratio than what was previously determined with the first set of audio processing algorithms. Further, by using available spare computational power, performance of the media playback device is not degraded as a result of the additional processing.

[0030] The improved audio signal may also be weighted. The weighing may be based on a confidence level. The improved audio signals may then be combined. The combined signal may result in cancellation of any noise in the improved audio signal processed by the second set of audio processing algorithms. This combined audio signal may be then passed to a computing device such as a server for further processing.

[0031] Moving on from the above illustration, in one example embodiment, a network device may comprise a network interface; a processor comprising instructions, which when executed, cause the processor to: receive a set of signal measures, wherein each signal measure in the set of signal measures corresponds to a respective audio signal received by a device in a media playback system which is processed based on a first set of audio processing algorithms; identify a plurality of signal measures in the set of signal measures; cause, via the network interface, audio

signals corresponding to the identified plurality of signal measures to be processed by one or more devices in the media playback system so as to improve a signal measure of each of the audio signals, wherein the audio signals are processed based on a second set of audio processing algorithms; and combine the processed audio signals into a combined audio signal. An algorithm of the second set of audio processing algorithms may process the audio signals based on content played by a playback device of the media playback system. Causing the audio signals corresponding to the identified plurality of signal measures to be processed by one or more devices in the media playback system may comprise receiving an indication of spare computational power from the one or more devices, identifying which devices have a spare computational power above a threshold amount, and causing the audio signals corresponding to the identified plurality of signal measures to be processed by the identified devices. A resolution of the first set of audio processing algorithms may be lower than a resolution of the second set of audio processing algorithms. The network device may further comprise instructions for causing the processor to send, via the network connection, the combined audio signal to a server. The first set of audio processing algorithms and the second set of audio processing algorithms may comprise one or more of an echo cancellation algorithm and a beamforming algorithm. Combining the processed audio signals into a combined audio signal may comprise weighting one or more of the processed audio signals. The audio signals may be impulse responses. A signal measure of the combined processed audio signals may be higher than any of the audio signals with improved signal measures. The identified plurality of signal measures in the set of signal measures may be those with signal to noise ratios above a threshold amount.

[0032] In another example embodiment, a method may comprise: receiving a set of signal measures, wherein each signal measure in the set of signal measures corresponds to a respective audio signal received by a device in a media playback system which is processed based on a first set of audio processing algorithms; identifying a plurality of signal measures in the set of signal measures; causing audio signals corresponding to the identified plurality of signal measures to be processed by one or more devices in the media playback system to improve a signal measure of each of the audio signals, wherein the audio signals are processed based on a second set of audio processing algorithms; and combining the processed audio signals into a combined audio signal. Causing the audio signals corresponding to the identified plurality of signal measures to be processed by one or more devices in the media playback system may comprise receiving an indication of spare computational power from each device in the media playback system, identifying which devices have a spare computational power above a threshold amount, and causing the audio signals corresponding to the identified plurality of signal measures to be processed by the identified devices. Combining the audio signals with improved signal measures into a combined audio signal may comprise weighting one or more of the processed audio signals. The method may further comprise sending the combined audio signal to a server. The first set of audio processing algorithms and the second set of audio processing algorithms may comprise one or more of an echo cancellation algorithm and a beamforming algo-

rithm. The identified plurality of signal measures in the set of signal measures may be those with signal to noise ratios above a threshold amount.

[0033] In yet another example embodiment, a computer readable storage medium may include instructions for execution by a processor, the instructions, when executed, cause the processor to implement a method comprising: receiving a set of signal measures, wherein each signal measure in the set of signal measures corresponds to a respective audio signal received by a device in a media playback system which is processed based on a first set of audio processing algorithms; identifying a plurality of signal measures in the set of signal measures; causing audio signals corresponding to the identified plurality of signal measures to be processed by one or more devices in the media playback system to improve a signal measure of each of the audio signals, wherein the audio signals are processed based on a second set of audio processing algorithms; and combining the processed audio signals into a combined audio signal. Causing the audio signals corresponding to the identified plurality of signal measures to be processed by one or more devices in the media playback system may comprise receiving an indication of spare computational power from the one or more devices, identifying which devices have a spare computational power above a threshold amount, and causing the audio signals corresponding to the identified plurality of signal measures to be processed by the identified devices. Combining the processed audio signals into a combined audio signal may comprise weighting one or more of the processed audio signals.

II. Example Operating Environment

[0034] FIG. 1 shows an example configuration of a media playback system 100 in which one or more embodiments disclosed herein may be practiced or implemented. The media playback system 100 as shown is associated with an example home environment having several rooms and spaces, such as for example, a master bedroom, an office, a dining room, and a living room. As shown in the example of FIG. 1, the media playback system 100 includes playback devices 102-124, control devices 126 and 128, and a wired or wireless network router 130.

[0035] Further discussions relating to the different components of the example media playback system 100 and how the different components may interact to provide a user with a media experience may be found in the following sections. While discussions herein may generally refer to the example media playback system 100, technologies described herein are not limited to applications within, among other things, the home environment as shown in FIG. 1. For instance, the technologies described herein may be useful in environments where multi-zone audio may be desired, such as, for example, a commercial setting like a restaurant, mall or airport, a vehicle like a sports utility vehicle (SUV), bus or car, a ship or boat, an airplane, and so on.

a. Example Playback Devices

[0036] FIG. 2 shows a functional block diagram of an example playback device 200 that may be configured to be one or more of the playback devices 102-124 of the media playback system 100 of FIG. 1. The playback device 200 may include a processor 202, software components 204, memory 206, audio processing components 208, audio amplifier(s) 210, speaker(s) 212, a network interface 214 including wireless interface(s) 216 and wired interface(s)

218, and microphone(s) 220. In one case, the playback device 200 may not include the speaker(s) 212, but rather a speaker interface for connecting the playback device 200 to external speakers. In another case, the playback device 200 may include neither the speaker(s) 212 nor the audio amplifier(s) 210, but rather an audio interface for connecting the playback device 200 to an external audio amplifier or audio-visual receiver.

[0037] In one example, the processor 202 may be a clock-driven computing component configured to process input data according to instructions stored in the memory 206. The memory 206 may be a tangible computer-readable medium configured to store instructions executable by the processor 202. For instance, the memory 206 may be data storage that can be loaded with one or more of the software components 204 executable by the processor 202 to achieve certain functions. In one example, the functions may involve the playback device 200 retrieving audio data from an audio source or another playback device. In another example, the functions may involve the playback device 200 sending audio data to another device or playback device on a network. In yet another example, the functions may involve pairing of the playback device 200 with one or more playback devices to create a multi-channel audio environment.

[0038] Certain functions may involve the playback device 200 synchronizing playback of audio content with one or more other playback devices. During synchronous playback, a listener will preferably not be able to perceive time-delay differences between playback of the audio content by the playback device 200 and the one or more other playback devices. U.S. Pat. No. 8,234,395 entitled, "System and method for synchronizing operations among a plurality of independently clocked digital data processing devices," which is hereby incorporated by reference, provides in more detail some examples for audio playback synchronization among playback devices.

[0039] The memory 206 may further be configured to store data associated with the playback device 200, such as one or more zones and/or zone groups the playback device 200 is a part of, audio sources accessible by the playback device 200, or a playback queue that the playback device 200 (or some other playback device) may be associated with. The data may be stored as one or more state variables that are periodically updated and used to describe the state of the playback device 200. The memory 206 may also include the data associated with the state of the other devices of the media system, and shared from time to time among the devices so that one or more of the devices have the most recent data associated with the system. Other embodiments are also possible.

[0040] The audio processing components 208 may include one or more digital-to-analog converters (DAC), an audio preprocessing component, an audio enhancement component or a digital signal processor (DSP), and so on. In one embodiment, one or more of the audio processing components 208 may be a subcomponent of the processor 202. In one example, audio content may be processed and/or intentionally altered by the audio processing components 208 to produce audio signals. The produced audio signals may then be provided to the audio amplifier(s) 210 for amplification and playback through speaker(s) 212. Particularly, the audio amplifier(s) 210 may include devices configured to amplify audio signals to a level for driving one or more of the

speakers 212. The speaker(s) 212 may include an individual transducer (e.g., a "driver") or a complete speaker system involving an enclosure with one or more drivers. A particular driver of the speaker(s) 212 may include, for example, a subwoofer (e.g., for low frequencies), a mid-range driver (e.g., for middle frequencies), and/or a tweeter (e.g., for high frequencies). In some cases, each transducer in the one or more speakers 212 may be driven by an individual corresponding audio amplifier of the audio amplifier(s) 210. In addition to producing analog signals for playback by the playback device 200, the audio processing components 208 may be configured to process audio content to be sent to one or more other playback devices for playback.

[0041] Audio content to be processed and/or played back by the playback device 200 may be received from an external source, such as via an audio line-in input connection (e.g., an auto-detecting 3.5 mm audio line-in connection) or the network interface 214.

[0042] The network interface 214 may be configured to facilitate a data flow between the playback device 200 and one or more other devices on a data network. As such, the playback device 200 may be configured to receive audio content over the data network from one or more other playback devices in communication with the playback device 200, network devices within a local area network, or audio content sources over a wide area network such as the Internet. In one example, the audio content and other signals transmitted and received by the playback device 200 may be transmitted in the form of digital packet data containing an Internet Protocol (IP)-based source address and IP-based destination addresses. In such a case, the network interface 214 may be configured to parse the digital packet data such that the data destined for the playback device 200 is properly received and processed by the playback device 200.

[0043] As shown, the network interface 214 may include wireless interface(s) 216 and wired interface(s) 218. The wireless interface(s) 216 may provide network interface functions for the playback device 200 to wirelessly communicate with other devices (e.g., other playback device(s), speaker(s), receiver(s), network device(s), control device(s) within a data network the playback device 200 is associated with) in accordance with a communication protocol (e.g., any wireless standard including IEEE 802.11a, 802.11b, 802.11g, 802.11n, 802.11ac, 802.15, 4G mobile communication standard, and so on). The wired interface(s) 218 may provide network interface functions for the playback device 200 to communicate over a wired connection with other devices in accordance with a communication protocol (e.g., IEEE 802.3). While the network interface 214 shown in FIG. 2 includes both wireless interface(s) 216 and wired interface(s) 218, the network interface 214 may in some embodiments include only wireless interface(s) or only wired interface(s).

[0044] The microphone(s) 220 may be arranged to detect sound in the environment of the playback device 200. For instance, the microphone(s) may be mounted on an exterior wall of a housing of the playback device. The microphone(s) may be any type of microphone now known or later developed such as a condenser microphone, electret condenser microphone, or a dynamic microphone. The microphone(s) may be sensitive to a portion of the frequency range of the speaker(s) 220. One or more of the speaker(s) 220 may

operate in reverse as the microphone(s) **220**. In some aspects, the playback device **200** might not have microphone(s) **220**.

[0045] In one example, the playback device **200** and one other playback device may be paired to play two separate audio components of audio content. For instance, playback device **200** may be configured to play a left channel audio component, while the other playback device may be configured to play a right channel audio component, thereby producing or enhancing a stereo effect of the audio content. The paired playback devices (also referred to as “bonded playback devices”) may further play audio content in synchrony with other playback devices.

[0046] In another example, the playback device **200** may be sonically consolidated with one or more other playback devices to form a single, consolidated playback device. A consolidated playback device may be configured to process and reproduce sound differently than an unconsolidated playback device or playback devices that are paired, because a consolidated playback device may have additional speaker drivers through which audio content may be rendered. For instance, if the playback device **200** is a playback device designed to render low frequency range audio content (i.e. a subwoofer), the playback device **200** may be consolidated with a playback device designed to render full frequency range audio content. In such a case, the full frequency range playback device, when consolidated with the low frequency playback device **200**, may be configured to render only the mid and high frequency components of audio content, while the low frequency range playback device **200** renders the low frequency component of the audio content. The consolidated playback device may further be paired with a single playback device or yet another consolidated playback device.

[0047] By way of illustration, SONOS, Inc. presently offers (or has offered) for sale certain playback devices including a “PLAY:1,” “PLAY:3,” “PLAY:5,” “PLAYBAR,” “CONNECT:AMP,” “CONNECT,” and “SUB.” Any other past, present, and/or future playback devices may additionally or alternatively be used to implement the playback devices of example embodiments disclosed herein. Additionally, it is understood that a playback device is not limited to the example illustrated in FIG. 2 or to the SONOS product offerings. For example, a playback device may include a wired or wireless headphone. In another example, a playback device may include or interact with a docking station for personal mobile media playback devices. In yet another example, a playback device may be integral to another device or component such as a television, a lighting fixture, or some other device for indoor or outdoor use.

b. Example Playback Zone Configurations

[0048] Referring back to the media playback system **100** of FIG. 1, the environment may have one or more playback zones, each with one or more playback devices. The media playback system **100** may be established with one or more playback zones, after which one or more zones may be added, or removed to arrive at the example configuration shown in FIG. 1. Each zone may be given a name according to a different room or space such as an office, bathroom, master bedroom, bedroom, kitchen, dining room, living room, and/or balcony. In one case, a single playback zone may include multiple rooms or spaces. In another case, a single room or space may include multiple playback zones.

[0049] As shown in FIG. 1, the balcony, dining room, kitchen, bathroom, office, and bedroom zones each have one playback device, while the living room and master bedroom zones each have multiple playback devices. In the living room zone, playback devices **104**, **106**, **108**, and **110** may be configured to play audio content in synchrony as individual playback devices, as one or more bonded playback devices, as one or more consolidated playback devices, or any combination thereof. Similarly, in the case of the master bedroom, playback devices **122** and **124** may be configured to play audio content in synchrony as individual playback devices, as a bonded playback device, or as a consolidated playback device.

[0050] In one example, one or more playback zones in the environment of FIG. 1 may each be playing different audio content. For instance, the user may be grilling in the balcony zone and listening to hip hop music being played by the playback device **102** while another user may be preparing food in the kitchen zone and listening to classical music being played by the playback device **114**. In another example, a playback zone may play the same audio content in synchrony with another playback zone. For instance, the user may be in the office zone where the playback device **118** is playing the same rock music that is being playing by playback device **102** in the balcony zone. In such a case, playback devices **102** and **118** may be playing the rock music in synchrony such that the user may seamlessly (or at least substantially seamlessly) enjoy the audio content that is being played out-loud while moving between different playback zones. Synchronization among playback zones may be achieved in a manner similar to that of synchronization among playback devices, as described in previously referenced U.S. Pat. No. 8,234,395.

[0051] As suggested above, the zone configurations of the media playback system **100** may be dynamically modified, and in some embodiments, the media playback system **100** supports numerous configurations. For instance, if a user physically moves one or more playback devices to or from a zone, the media playback system **100** may be reconfigured to accommodate the change(s). For instance, if the user physically moves the playback device **102** from the balcony zone to the office zone, the office zone may now include both the playback device **118** and the playback device **102**. The playback device **102** may be paired or grouped with the office zone and/or renamed if so desired via a control device such as the control devices **126** and **128**. On the other hand, if the one or more playback devices are moved to a particular area in the home environment that is not already a playback zone, a new playback zone may be created for the particular area.

[0052] Further, different playback zones of the media playback system **100** may be dynamically combined into zone groups or split up into individual playback zones. For instance, the dining room zone and the kitchen zone **114** may be combined into a zone group for a dinner party such that playback devices **112** and **114** may render audio content in synchrony. On the other hand, the living room zone may be split into a television zone including playback device **104**, and a listening zone including playback devices **106**, **108**, and **110**, if the user wishes to listen to music in the living room space while another user wishes to watch television.

c. Example Control Devices

[0053] FIG. 3 shows a functional block diagram of an example control device **300** that may be configured to be one

or both of the control devices 126 and 128 of the media playback system 100. As shown, the control device 300 may include a processor 302, memory 304, a network interface 306, a user interface 308, microphone(s) 310, and software components 312. In one example, the control device 300 may be a dedicated controller for the media playback system 100. In another example, the control device 300 may be a network device on which media playback system controller application software may be installed, such as for example, an iPhone™, iPad™ or any other smart phone, tablet or network device (e.g., a networked computer such as a PC or Mac™).

[0054] The processor 302 may be configured to perform functions relevant to facilitating user access, control, and configuration of the media playback system 100. The memory 304 may be data storage that can be loaded with one or more of the software components executable by the processor 302 to perform those functions. The memory 304 may also be configured to store the media playback system controller application software and other data associated with the media playback system 100 and the user.

[0055] In one example, the network interface 306 may be based on an industry standard (e.g., infrared, radio, wired standards including IEEE 802.3, wireless standards including IEEE 802.11a, 802.11b, 802.11g, 802.11n, 802.11ac, 802.15, 4G mobile communication standard, and so on). The network interface 306 may provide a means for the control device 300 to communicate with other devices in the media playback system 100. In one example, data and information (e.g., such as a state variable) may be communicated between control device 300 and other devices via the network interface 306. For instance, playback zone and zone group configurations in the media playback system 100 may be received by the control device 300 from a playback device or another network device, or transmitted by the control device 300 to another playback device or network device via the network interface 306. In some cases, the other network device may be another control device.

[0056] Playback device control commands such as volume control and audio playback control may also be communicated from the control device 300 to a playback device via the network interface 306. As suggested above, changes to configurations of the media playback system 100 may also be performed by a user using the control device 300. The configuration changes may include adding/removing one or more playback devices to/from a zone, adding/removing one or more zones to/from a zone group, forming a bonded or consolidated player, separating one or more playback devices from a bonded or consolidated player, among others. Accordingly, the control device 300 may sometimes be referred to as a controller, whether the control device 300 is a dedicated controller or a network device on which media playback system controller application software is installed.

[0057] Control device 300 may include microphone(s) 310. Microphone(s) 310 may be arranged to detect sound in the environment of the control device 300. Microphone(s) 310 may be any type of microphone now known or later developed such as a condenser microphone, electret condenser microphone, or a dynamic microphone. The microphone(s) may be sensitive to a portion of a frequency range. Two or more microphones 310 may be arranged to capture location information of an audio source (e.g., voice, audible sound) and/or to assist in filtering background noise.

[0058] The user interface 308 of the control device 300 may be configured to facilitate user access and control of the media playback system 100, by providing a controller interface such as the controller interface 400 shown in FIG. 4. The controller interface 400 includes a playback control region 410, a playback zone region 420, a playback status region 430, a playback queue region 440, and an audio content sources region 450. The user interface 400 as shown is just one example of a user interface that may be provided on a network device such as the control device 300 of FIG. 3 (and/or the control devices 126 and 128 of FIG. 1) and accessed by users to control a media playback system such as the media playback system 100. Other user interfaces of varying formats, styles, and interactive sequences may alternatively be implemented on one or more network devices to provide comparable control access to a media playback system.

[0059] The playback control region 410 may include selectable (e.g., by way of touch or by using a cursor) icons to cause playback devices in a selected playback zone or zone group to play or pause, fast forward, rewind, skip to next, skip to previous, enter/exit shuffle mode, enter/exit repeat mode, enter/exit cross fade mode. The playback control region 410 may also include selectable icons to modify equalization settings, and playback volume, among other possibilities.

[0060] The playback zone region 420 may include representations of playback zones within the media playback system 100. In some embodiments, the graphical representations of playback zones may be selectable to bring up additional selectable icons to manage or configure the playback zones in the media playback system, such as a creation of bonded zones, creation of zone groups, separation of zone groups, and renaming of zone groups, among other possibilities.

[0061] For example, as shown, a “group” icon may be provided within each of the graphical representations of playback zones. The “group” icon provided within a graphical representation of a particular zone may be selectable to bring up options to select one or more other zones in the media playback system to be grouped with the particular zone. Once grouped, playback devices in the zones that have been grouped with the particular zone will be configured to play audio content in synchrony with the playback device(s) in the particular zone. Analogously, a “group” icon may be provided within a graphical representation of a zone group. In this case, the “group” icon may be selectable to bring up options to deselect one or more zones in the zone group to be removed from the zone group. Other interactions and implementations for grouping and ungrouping zones via a user interface such as the user interface 400 are also possible. The representations of playback zones in the playback zone region 420 may be dynamically updated as playback zone or zone group configurations are modified.

[0062] The playback status region 430 may include graphical representations of audio content that is presently being played, previously played, or scheduled to play next in the selected playback zone or zone group. The selected playback zone or zone group may be visually distinguished on the user interface, such as within the playback zone region 420 and/or the playback status region 430. The graphical representations may include track title, artist name, album name, album year, track length, and other

relevant information that may be useful for the user to know when controlling the media playback system via the user interface **400**.

[0063] The playback queue region **440** may include graphical representations of audio content in a playback queue associated with the selected playback zone or zone group. In some embodiments, each playback zone or zone group may be associated with a playback queue containing information corresponding to zero or more audio items for playback by the playback zone or zone group. For instance, each audio item in the playback queue may comprise a uniform resource identifier (URI), a uniform resource locator (URL) or some other identifier that may be used by a playback device in the playback zone or zone group to find and/or retrieve the audio item from a local audio content source or a networked audio content source, possibly for playback by the playback device.

[0064] In one example, a playlist may be added to a playback queue, in which case information corresponding to each audio item in the playlist may be added to the playback queue. In another example, audio items in a playback queue may be saved as a playlist. In a further example, a playback queue may be empty, or populated but “not in use” when the playback zone or zone group is playing continuously streaming audio content, such as Internet radio that may continue to play until otherwise stopped, rather than discrete audio items that have playback durations. In an alternative embodiment, a playback queue can include Internet radio and/or other streaming audio content items and be “in use” when the playback zone or zone group is playing those items. Other examples are also possible.

[0065] When playback zones or zone groups are “grouped” or “ungrouped,” playback queues associated with the affected playback zones or zone groups may be cleared or re-associated. For example, if a first playback zone including a first playback queue is grouped with a second playback zone including a second playback queue, the established zone group may have an associated playback queue that is initially empty, that contains audio items from the first playback queue (such as if the second playback zone was added to the first playback zone), that contains audio items from the second playback queue (such as if the first playback zone was added to the second playback zone), or a combination of audio items from both the first and second playback queues. Subsequently, if the established zone group is ungrouped, the resulting first playback zone may be re-associated with the previous first playback queue, or be associated with a new playback queue that is empty or contains audio items from the playback queue associated with the established zone group before the established zone group was ungrouped. Similarly, the resulting second playback zone may be re-associated with the previous second playback queue, or be associated with a new playback queue that is empty, or contains audio items from the playback queue associated with the established zone group before the established zone group was ungrouped. Other examples are also possible.

[0066] Referring back to the user interface **400** of FIG. **4**, the graphical representations of audio content in the playback queue region **440** may include track titles, artist names, track lengths, and other relevant information associated with the audio content in the playback queue. In one example, graphical representations of audio content may be selectable to bring up additional selectable icons to manage and/or

manipulate the playback queue and/or audio content represented in the playback queue. For instance, a represented audio content may be removed from the playback queue, moved to a different position within the playback queue, or selected to be played immediately, or after any currently playing audio content, among other possibilities. A playback queue associated with a playback zone or zone group may be stored in a memory on one or more playback devices in the playback zone or zone group, on a playback device that is not in the playback zone or zone group, and/or some other designated device.

[0067] The audio content sources region **450** may include graphical representations of selectable audio content sources from which audio content may be retrieved and played by the selected playback zone or zone group. Discussions pertaining to audio content sources may be found in the following section.

d. Example Audio Content Sources

[0068] As indicated previously, one or more playback devices in a zone or zone group may be configured to retrieve for playback audio content (e.g. according to a corresponding URI or URL for the audio content) from a variety of available audio content sources. In one example, audio content may be retrieved by a playback device directly from a corresponding audio content source (e.g., a line-in connection). In another example, audio content may be provided to a playback device over a network via one or more other playback devices or network devices.

[0069] Example audio content sources may include a memory of one or more playback devices in a media playback system such as the media playback system **100** of FIG. **1**, local music libraries on one or more network devices (such as a control device, a network-enabled personal computer, or a networked-attached storage (NAS), for example), streaming audio services providing audio content via the Internet (e.g., the cloud), or audio sources connected to the media playback system via a line-in input connection on a playback device or network device, among other possibilities.

[0070] In some embodiments, audio content sources may be regularly added or removed from a media playback system such as the media playback system **100** of FIG. **1**. In one example, an indexing of audio items may be performed whenever one or more audio content sources are added, removed or updated. Indexing of audio items may involve scanning for identifiable audio items in all folders/directory shared over a network accessible by playback devices in the media playback system, and generating or updating an audio content database containing metadata (e.g., title, artist, album, track length, among others) and other associated information, such as a URI or URL for each identifiable audio item found. Other examples for managing and maintaining audio content sources may also be possible.

[0071] The above discussions relating to playback devices, controller devices, playback zone configurations, and media content sources provide only some examples of operating environments within which functions and methods described below may be implemented. Other operating environments and configurations of media playback systems, playback devices, and network devices not explicitly described herein may also be applicable and suitable for implementation of the functions and methods.

e. Example Plurality of Networked Devices

[0072] FIG. 5 shows an example plurality of devices 500 that may be configured to provide an audio playback experience based on voice control. One having ordinary skill in the art will appreciate that the devices shown in FIG. 5 are for illustrative purposes only, and variations including different and/or additional devices may be possible. As shown, the plurality of devices 500 includes computing devices 504, 506, and 508; network microphone devices (NMDs) 512, 514, and 516; playback devices (PBDs) 532, 534, 536, and 538; and a controller device (CR) 522.

[0073] Each of the plurality of devices 500 may be network-capable devices that can establish communication with one or more other devices in the plurality of devices according to one or more network protocols, such as NFC, Bluetooth, Ethernet, and IEEE 802.11, among other examples, over one or more types of networks, such as wide area networks (WAN), local area networks (LAN), and personal area networks (PAN), among other possibilities.

[0074] As shown, the computing devices 504, 506, and 508 may be part of a cloud network 502. The cloud network 502 may include additional computing devices. In one example, the computing devices 504, 506, and 508 may be different servers. In another example, two or more of the computing devices 504, 506, and 508 may be modules of a single server. Analogously, each of the computing device 504, 506, and 508 may include one or more modules or servers. For ease of illustration purposes herein, each of the computing devices 504, 506, and 508 may be configured to perform particular functions within the cloud network 502. For instance, computing device 508 may be a source of audio content for a streaming music service.

[0075] As shown, the computing device 504 may be configured to interface with NMDs 512, 514, and 516 via communication path 542. NMDs 512, 514, and 516 may be components of one or more “Smart Home” systems. In one case, NMDs 512, 514, and 516 may be physically distributed throughout a household, similar to the distribution of devices shown in FIG. 1. In another case, two or more of the NMDs 512, 514, and 516 may be physically positioned within relative close proximity of one another. Communication path 542 may comprise one or more types of networks, such as a WAN including the Internet, LAN, and/or PAN, among other possibilities.

[0076] In one example, one or more of the NMDs 512, 514, and 516 may be devices configured primarily for audio detection. In another example, one or more of the NMDs 512, 514, and 516 may be components of devices having various primary utilities. For instance, as discussed above in connection to FIGS. 2 and 3, one or more of NMDs 512, 514, and 516 may be the microphone(s) 220 of playback device 200 or the microphone(s) 310 of network device 300. Further, in some cases, one or more of NMDs 512, 514, and 516 may be the playback device 200 or network device 300. In an example, one or more of NMDs 512, 514, and/or 516 may include multiple microphones arranged in a microphone array.

[0077] As shown, the computing device 506 may be configured to interface with CR 522 and PBDs 532, 534, 536, and 538 via communication path 544. In one example, CR 522 may be a network device such as the network device 200 of FIG. 2. Accordingly, CR 522 may be configured to provide the controller interface 400 of FIG. 4. Similarly, PBDs 532, 534, 536, and 538 may be playback devices such

as the playback device 300 of FIG. 3. As such, PBDs 532, 534, 536, and 538 may be physically distributed throughout a household as shown in FIG. 1. For illustration purposes, PBDs 536 and 538 may be part of a bonded zone 530, while PBDs 532 and 534 may be part of their own respective zones. As described above, the PBDs 532, 534, 536, and 538 may be dynamically bonded, grouped, unbonded, and ungrouped. Communication path 544 may comprise one or more types of networks, such as a WAN including the Internet, LAN, and/or PAN, among other possibilities.

[0078] In one example, as with NMDs 512, 514, and 516, CR 522 and PBDs 532, 534, 536, and 538 may also be components of one or more “Smart Home” systems. In one case, PBDs 532, 534, 536, and 538 may be distributed throughout the same household as the NMDs 512, 514, and 516. Further, as suggested above, one or more of PBDs 532, 534, 536, and 538 may be one or more of NMDs 512, 514, and 516.

[0079] The NMDs 512, 514, and 516 may be part of a local area network, and the communication path 542 may include an access point that links the local area network of the NMDs 512, 514, and 516 to the computing device 504 over a WAN (communication path not shown). Likewise, each of the NMDs 512, 514, and 516 may communicate with each other via such an access point.

[0080] Similarly, CR 522 and PBDs 532, 534, 536, and 538 may be part of a local area network and/or a local playback network as discussed in previous sections, and the communication path 544 may include an access point that links the local area network and/or local playback network of CR 522 and PBDs 532, 534, 536, and 538 to the computing device 506 over a WAN. As such, each of the CR 522 and PBDs 532, 534, 536, and 538 may also communicate with each other over such an access point.

[0081] In one example, communication paths 542 and 544 may comprise the same access point. In an example, each of the NMDs 512, 514, and 516, CR 522, and PBDs 532, 534, 536, and 538 may access the cloud network 502 via the same access point for a household.

[0082] As shown in FIG. 5, each of the NMDs 512, 514, and 516, CR 522, and PBDs 532, 534, 536, and 538 may also directly communicate with one or more of the other devices via communication means 546. Communication means 546 as described herein may involve one or more forms of communication between the devices, according to one or more network protocols, over one or more types of networks, and/or may involve communication via one or more other network devices. For instance, communication means 546 may include one or more of for example, Bluetooth™ (IEEE 802.15), NFC, Wireless direct, and/or Proprietary wireless, among other possibilities.

[0083] In one example, CR 522 may communicate with NMD 512 over Bluetooth™, and communicate with PBD 534 over another local area network. In another example, NMD 514 may communicate with CR 522 over another local area network, and communicate with PBD 536 over Bluetooth. In a further example, each of the PBDs 532, 534, 536, and 538 may communicate with each other according to a spanning tree protocol over a local playback network, while each communicating with CR 522 over a local area network, different from the local playback network. Other examples are also possible.

[0084] In some cases, communication means between the NMDs 512, 514, and 516, CR 522, and PBDs 532, 534, 536,

and 538 may change depending on types of communication between the devices, network conditions, and/or latency demands. For instance, communication means 546 may be used when NMD 516 is first introduced to the household with the PBDs 532, 534, 536, and 538. In one case, the NMD 516 may transmit identification information corresponding to the NMD 516 to PBD 538 via NFC, and PBD 538 may in response, transmit local area network information to NMD 516 via NFC (or some other form of communication). However, once NMD 516 has been configured within the household, communication means between NMD 516 and PBD 538 may change. For instance, NMD 516 may subsequently communicate with PBD 538 via communication path 542, the cloud network 502, and communication path 544. In another example, the NMDs and PBDs may never communicate via local communications means 546. In a further example, the NMDs and PBDs may communicate primarily via local communications means 546. Other examples are also possible.

[0085] In an illustrative example, NMDs 512, 514, and 516 may be configured to receive voice inputs to control PBDs 532, 534, 536, and 538. The available control commands may include any media playback system controls previously discussed, such as playback volume control, playback transport controls, music source selection, and grouping, among other possibilities. In one instance, NMD 512 may receive a voice input to control one or more of the PBDs 532, 534, 536, and 538. In response to receiving the voice input, NMD 512 may transmit via communication path 542, the voice input to computing device 504 for processing. In one example, the computing device 504 may convert the voice input to an equivalent text command, and parse the text command to identify a command. Computing device 504 may then subsequently transmit the text command to the computing device 506. In another example, the computing device 504 may convert the voice input to an equivalent text command, and then subsequently transmit the text command to the computing device 506. The computing device 506 may then parse the text command to identify one or more playback commands.

[0086] For instance, if the text command is “Play ‘Track 1’ by ‘Artist 1’ from ‘Streaming Service 1’ in ‘Zone 1,’” The computing device 506 may identify (i) a URL for “Track 1” by “Artist 1” available from “Streaming Service 1,” and (ii) at least one playback device in “Zone 1.” In this example, the URL for “Track 1” by “Artist 1” from “Streaming Service 1” may be a URL pointing to computing device 508, and “Zone 1” may be the bonded zone 530. As such, upon identifying the URL and one or both of PBDs 536 and 538, the computing device 506 may transmit via communication path 544 to one or both of PBDs 536 and 538, the identified URL for playback. One or both of PBDs 536 and 538 may responsively retrieve audio content from the computing device 508 according to the received URL, and begin playing “Track 1” by “Artist 1” from “Streaming Service 1.”

[0087] One having ordinary skill in the art will appreciate that the above is just one illustrative example, and that other implementations are also possible. In one case, operations performed by one or more of the plurality of devices 500, as described above, may be performed by one or more other devices in the plurality of device 500. For instance, the conversion from voice input to the text command may be alternatively, partially, or wholly performed by another device or devices, such as NMD 512, computing device 506,

PBD 536, and/or PBD 538. Analogously, the identification of the URL may be alternatively, partially, or wholly performed by another device or devices, such as NMD 512, computing device 504, PBD 536, and/or PBD 538.

f. Example Network Microphone Device

[0088] FIG. 6 shows a function block diagram of an example network microphone device 600 that may be configured to be one or more of NMDs 512, 514, and 516 of FIG. 5. As shown, the network microphone device 600 includes a processor 602, memory 604, a microphone array 606, a network interface 608, a user interface 610, software components 612, and speaker(s) 614. One having ordinary skill in the art will appreciate that other network microphone device configurations and arrangements are also possible. For instance, network microphone devices may alternatively exclude the speaker(s) 614 or have a single microphone instead of microphone array 606.

[0089] The processor 602 may include one or more processors and/or controllers, which may take the form of a general or special-purpose processor or controller. For instance, the processing unit 602 may include microprocessors, microcontrollers, application-specific integrated circuits, digital signal processors, and the like. The memory 604 may be data storage that can be loaded with one or more of the software components executable by the processor 602 to perform those functions. Accordingly, memory 604 may comprise one or more non-transitory computer-readable storage mediums, examples of which may include volatile storage mediums such as random access memory, registers, cache, etc. and non-volatile storage mediums such as read-only memory, a hard-disk drive, a solid-state drive, flash memory, and/or an optical-storage device, among other possibilities.

[0090] The microphone array 606 may be a plurality of microphones arranged to detect sound in the environment of the network microphone device 600. Microphone array 606 may include any type of microphone now known or later developed such as a condenser microphone, electret condenser microphone, or a dynamic microphone, among other possibilities. In one example, the microphone array may be arranged to detect audio from one or more directions relative to the network microphone device. The microphone array 606 may be sensitive to a portion of a frequency range. In one example, a first subset of the microphone array 606 may be sensitive to a first frequency range, while a second subset of the microphone array may be sensitive to a second frequency range. The microphone array 606 may further be arranged to capture location information of an audio source (e.g., voice, audible sound) and/or to assist in filtering background noise. Notably, in some embodiments the microphone array may consist of only a single microphone, rather than a plurality of microphones.

[0091] The network interface 608 may be configured to facilitate wireless and/or wired communication between various network devices, such as, in reference to FIG. 5, CR 522, PBDs 532-538, computing device 504-508 in cloud network 502, and other network microphone devices, among other possibilities. As such, network interface 608 may take any suitable form for carrying out these functions, examples of which may include an Ethernet interface, a serial bus interface (e.g., FireWire, USB 2.0, etc.), a chipset and antenna adapted to facilitate wireless communication, and/or any other interface that provides for wired and/or wireless communication. In one example, the network interface 608

may be based on an industry standard (e.g., infrared, radio, wired standards including IEEE 802.3, wireless standards including IEEE 802.11a, 802.11b, 802.11g, 802.11n, 802.11ac, 802.15, 4G mobile communication standard, and so on).

[0092] The user interface **610** of the network microphone device **600** may be configured to facilitate user interactions with the network microphone device. In one example, the user interface **608** may include one or more of physical buttons, graphical interfaces provided on touch sensitive screen(s) and/or surface(s), among other possibilities, for a user to directly provide input to the network microphone device **600**. The user interface **610** may further include one or more of lights and the speaker(s) **614** to provide visual and/or audio feedback to a user. In one example, the network microphone device **600** may further be configured to playback audio content via the speaker(s) **614**.

III. Example Systems

[0093] The playback device, the controller device, and the network microphone device may be in an environment such as a living room in a home. The microphone array of one or more of these devices may receive an audio signal. The audio signal may include an indication of a sonic input and noise. The sonic input may be a voice input such as a request to perform an action associated with the media playback system, e.g., “play audio” or “stop playing audio”. The sonic input may take the form of any other voice input as well. The noise could include white noise or impulse noise. Alternatively, the “noise” could be audio content played by a playback device in the media playback system.

[0094] It may be desirable to recover the sonic input from the audio signal that is received via the microphone array of a device. Examples described herein are directed to distributing, across devices in the media playback system, processing associated with improving a signal measure (e.g., signal to noise ratio) of the audio signal received by a device in the media playback system prior to the recovery of the sonic input. The processing is distributed to reduce degradation in performance of a particular device in the media playback system while the signal to noise ratio is improved. Improving the signal to noise ratio results in attenuating noise in the audio signal. The improved audio signal may then be passed to a computing device such as a server which is arranged to recover the sonic input. If the sonic input is a voice input, the server may further interpret from voice input the action associated with the voice input such as “play music on a playback device” or to “turn off the playback device”. The server may then cause the media playback system to perform the action.

[0095] FIG. 7 illustrates an example environment **700** where audio signals may be present. The example environment may be a room of a home, such as a living room or bedroom, which has a media playback system for playing audio content. The media playback system may include one or more playback devices **702**, network microphone devices **704**, controller devices **706**, and/or computing devices (not shown). The playback device **702** may have one or more microphones (e.g., microphone arrays) for receiving an audio signal, one or more speakers for playing back audio content, and a processor for playing back the audio content. The network microphone device **704** may have one or more microphones (e.g., microphone arrays) for receiving the audio signal and a processor for transmitting the received

audio signal to the computing device. The controller device **706** may have one or more microphones (e.g., microphone arrays) for receiving an audio signal and a processor for controlling the one or more playback devices in the media playback system. The computing device may be a server which is arranged with a processor to perform various processing associated with the media playback system. The processing may include processing of the audio signal sent by the network microphone device **704**. The computing device may be located remote to devices in the environment **700** such as in a cloud network. The computing device may also source audio content to the one or more playback devices for playback.

[0096] The example environment **700** may also have an audio source **710**. The audio source **710** may provide a sonic input. For example, the audio source **710** may be a user of the media playback system who speaks in the environment. In this case, the audio source may be a voice input. The sonic input produced by the audio source **710** may be directed in one or more directions. In one example, the sonic input may be generally directed toward a device in the media playback system. In another example, sonic input may be directed away from the device in the media playback system. In yet another example, the sonic input may be directed uniformly in all directions throughout the environment. In this regard, one or more of the microphone arrays of the playback device **702**, NMD **704**, and/or controller device **706** may receive an audio signal that includes an indication of the sonic input.

[0097] The audio signal received by the microphone array may also receive any noise present in the environment. The noise may be audio that is received by the device aside from the sonic input. For example, the noise may include an attenuated version of the sonic input, and echoes of the sonic input, as a result of the sonic input traveling through the environment, bouncing off walls and objects in the environment before reaching a microphone array. The “noise” could also be any audio content being played back by a playback device such as music.

[0098] A signal to noise ratio is a signal measure indicative of a comparison of a desired signal in the audio signal to the noise in the audio signal. The desired signal may be the sonic input in the audio signal and the noise may be audio other than the sonic input in the audio signal. The audio signal may have a relatively high signal to noise ratio if the device which receives the audio signal is in a same direction as the sonic input. For example, the NMD **704** in the upper left corner of the environment **700** may receive an audio signal with a high signal to noise ratio because the audio source **710** is outputting a sonic input in the direction of the NMD **704**. On the other hand, the audio signal may have a relatively low signal to noise ratio if the device which receives the audio signal is not in a same direction as the audio source **710**. For example, the NMD **704** in the lower right corner of the environment **700** may receive an audio signal with a low signal to noise ratio because the audio source **710** is not outputting a sonic input in the direction of the NMD **704**. The microphone array of the NMD **704** may still receive the sonic input, but indirectly, for example, as a result of the sonic input bouncing off walls of the environment, objects in the environment such as furniture, or the ceiling in the environment and reaching the microphone array.

[0099] In one example, the signal to noise ratio can be improved using echo cancellation. The microphone array

may receive multiple versions of the audio signal having different phases and magnitudes depending on the path that the audio signal took to reach the microphone array. For example, the audio signal may bounce off objects in an environment, such as furniture, walls, and the ceiling, before being received by the microphone array. The microphone array may receive multiple versions of the audio signal, i.e., echoes, and the multiple versions may arrive at the microphone array at different times depending on how long the audio signal takes to travel from the source to the microphone array.

[0100] Echo cancellation seeks to remove such “echoes” in the received audio signal. The audio signal that is received by the microphone array may be represented as a plurality of impulse responses. Each impulse response may be associated with a microphone of the microphone array. The impulse responses may be time aligned based on a distance between microphones associated with a respective impulse response and combined into a single signal, e.g., a combined impulse response. Then, the combined impulse response may be divided into windows of time. For example, an impulse response of 1000 ms may be divided into overlapping and/or non-overlapping windows of impulse responses of 100 ms for processing. The size of the windows of time may determine the improvement of the signal to noise ratio, e.g., a larger window results in a better signal to noise ratio. The echoes may be removed in each window of time through an adaptive filtering process. Further, the combined impulse responses could be compared to echo characteristics of various sonic inputs. For example, the computing device may have a database of echo characteristics for the various sonic inputs. These echo characteristics may have been determined during a calibration process of the microphone array and/or stored in a database on the computing device. The comparison may result in determining a likelihood that a signal in the combined impulse response is a sonic input. The likelihood determination facilitates isolating the sonic input from echoes in the audio signal to improve the signal to noise ratio of the audio signal.

[0101] As another example, the signal to noise ratio can be improved using beamforming. In a polar domain, the audio signal may be present in a range of 0 to 360 degrees around the microphone array, albeit at different magnitudes and phases depending on how the sonic input travels from the audio source **710** to a microphone array. The microphone array may be arranged to capture the audio signals in an angular range of the 360 degrees. For example, NMD **704** in the upper left corner of the environment **700** is shown at **712** to capture audio in a 100 degree angular range. The audio signal received over a certain angular range, may be divided into angular intervals **714**. For example, in the polar domain, the audio signal may be received at over a 100 degree angular range which is divided into five 20 degree angular intervals. Applying beamforming over a larger angular range and/or a smaller angular interval may result in an improved signal to noise ratio.

[0102] The audio signal received in an angular interval may have certain characteristics. The characteristics of the audio signal may be compared to known characteristics when a sonic input originates in that direction. These known characteristics may have been determined during a calibration process of the microphone array and/or stored in a database on the computing device. For example, an impulse response of the audio signal may be compared to a known

impulse response when sonic input originated from a particular direction. This comparison may provide a likelihood that the sonic input of the audio signal originates in that particular direction. The direction of the sonic input may then be used by the beamforming algorithm to improve the signal to noise ratio of the audio signal.

[0103] If a playback device in the media playback system is playing audio at the same time that the microphone array receives the audio signal, then yet another algorithm (herein referred to as “subtraction of known signal method” and variants) may be used to improve the signal to noise ratio of the audio signal. The audio playing in the background is known to the media playback system. It may be stored in an audio file or streaming from a server. This known audio can be subtracted from the received audio signal to improve the signal to noise ratio of the audio signal. For example, the audio playing in the background and the audio signal may be represented as impulse responses of a certain duration. The impulse response of the audio playing in the background may be subtracted from the received audio signal so as to attenuate the audio that is being played from the audio signal and improve the signal to noise ratio of the audio signal.

[0104] The signal to noise ratio may be further improved based on one or more of a microphone response of the microphone array, a playback device response, and a room response. The microphone array may have a response indicative of its audio sensitivity versus frequency. The playback device may have a response indicative its audio output versus frequency. The room response may be indicative of acoustic characteristics of the room as described in U.S. patent application Ser. No. 14/481,511, entitled “Playback Device Calibration”, the contents of which is herein incorporated by reference in its entirety. The microphone array response, the playback device response, and a room response may be used to improve the signal to noise ratio. For example, an inverse of the microphone array response, an inverse of the playback device response, and an inverse of the room response may be applied to the audio signal received by the microphone array prior to subtracting the impulse response of the audio being played back to improve the signal to noise ratio of the audio signal. The responses may also be used to improve the signal measures determined by the other algorithms as well.

[0105] The methods described above are examples of various methods of improving the signal to noise ratio. One or several algorithms may be applied or combined to improve the signal to noise ratio of the audio signal. An arrangement among a playback device playing audio, a microphone array, and an audio source may determine the type of audio improvement algorithm that is applied and the order in which it is applied. For example, if the playback device plays audio content and the audio source produces sonic input in a same direction toward the microphone array, then the subtraction of the known audio method may be applied to improve the signal to noise ratio. Beamforming may not be effective because the audio source and playback device are facing in the same direction and the beamforming would not be able to isolate the sonic input in view of the audio being played back by the playback device in the same direction. Then, echo cancellation method may be applied to cancel out any echoes associated with reverberation in the environment. As another example, the microphone array may be in between the playback device and the audio source. If the audio source produces sonic input in a direction of the

playback device and the playback device plays audio in the direction of the audio source, then the beamforming may be applied first if the microphone array is facing in the same direction as the audio source. Then, an echo cancellation may be used to cancel echoes. Other arrangements are also possible in accordance with the disclosed embodiments and the arrangement of the media playback system in the environment.

[0106] The audio signal, as processed by one or more signal to noise improvement methods may be referred to herein as an improved audio signal. In embodiments, the audio signal received by the microphone array and the improved audio signal may be stored on the playback device, controller device, or computing device as an audio file. The audio signal may be a digital file representing a spectral response or temporal response. The spectral response may be an indication of how the audio signal captured by the microphone array and the improved audio signal varies with frequency. A power spectral density is an example representation of the spectral response. The temporal response may be an indication of how the audio signal and the improved audio signal changes within the room. The change may be characterized as a reverberation, delay, decay, or phase change of the audio signal. Additionally, or alternatively, the audio signal and improved audio signal may be represented as a set of impulse responses or bi-quad filter coefficients representative of the audio signal, among others.

[0107] In the case of the audio signal being represented as impulse responses, the signal to noise ratio of the improved audio signal may be calculated by dividing the impulse response of the improved audio signal with the received audio signal. As yet another example, the beamforming method may define a probability density function which indicates a likelihood that the sonic input the audio signal originates in a particular direction. An integral of the probability density function may be indicative of a signal to noise ratio of the improved audio signal. Still alternatively, the signal to noise ratio may be based on determining for the probability density function those directions where a first derivative of the likelihood is maximized, and integrating those regions to calculate the signal to noise ratio for the improved audio signal. Other arrangements are also possible for calculating a signal to noise ratio.

[0108] At least one signal to noise ratio or a plurality of signal to noise ratios may be associated with a microphone array. For example, the echo cancellation algorithm provides an improved audio signal based on the audio signal received by the microphone array. The signal to noise ratio of this improved audio signal may be calculated and associated with the microphone array. As another example, beamforming may be performed in a plurality of directions to improve an audio signal received in a particular direction. The signal to noise ratio of this improved audio signal with respect to direction may be calculated and associated with the microphone array. For example, the audio signal may be processed at directions of 20 degree angular intervals around the microphone array. Each 20 degree angular interval may have associated impulse response of the received audio signal, impulse response of the improved audio signal, and signal to noise ratio.

[0109] FIGS. 8 and 9 present respective embodiments that can be implemented within the disclosed operating environment. Methods and the other process disclosed herein may

include one or more operations, functions, or actions. Although the blocks are illustrated in sequential order, these blocks may also be performed in parallel, and/or in a different order than those described herein. Also, the various blocks may be combined into fewer blocks, divided into additional blocks, and/or removed based upon the desired implementation.

[0110] In addition, for the methods and other processes and methods disclosed herein, the flowchart shows functionality and operation of one possible implementation of present embodiments. In this regard, each block may represent a module, a segment, or a portion of program code, which includes one or more instructions executable by a processor for implementing specific logical functions or steps in the process. The program code may be stored on any type of computer readable medium, for example, such as a storage device including a disk or hard drive. The computer readable medium may include non-transitory computer readable medium, for example, such as computer-readable media that stores data for short periods of time like register memory, processor cache and Random Access Memory (RAM). The computer readable medium may also include non-transitory media, such as secondary or persistent long term storage, like read only memory (ROM), optical or magnetic disks, compact-disc read only memory (CD-ROM), for example. The computer readable media may also be any other volatile or non-volatile storage systems. The computer readable medium may be considered a computer readable storage medium, for example, or a tangible storage device. In addition, each block in the figures may represent circuitry that is wired to perform the specific logical functions in the process.

[0111] FIG. 8 is a flow chart 800 of functions associated with distributed processing to improving a signal measure, e.g., signal to noise ratio, of an audio signal received by a plurality of devices in a media playback system. In one example, the disclosed functions may be coordinated and at least partially performed by a playback device, such as one of the one or more playback devices in the media playback system. In another example, the disclosed functions may be coordinated and at least partially performed by a computing device. In yet another example, the functions may be coordinated and at least partially performed by a controller device. In another example, the disclosed functions may be coordinated and at least partially performed by a NMD. Other arrangements are also possible.

[0112] Referring to FIG. 8, at 802, a set of signal measures corresponding to audio signals processed based on first set of audio processing algorithms may be received. At 804, a plurality of signal measures in the set of signal measures may be identified. Then, at 806, the audio signals corresponding to the identified plurality of signal measures may be processed by one or more devices in the media playback system based on a second set of audio processing algorithms. Additionally, the audio signals may be processed based on spare computational power of a device of the one or more devices. At 808, the processed audio signals may be combined to produce a combined audio signal. The combined audio signal may have an improved signal measure such as a signal to noise ratio as compared to the audio signals processed at 802 and at 806. This improved signal measure allows for improved recovery of a sonic input of the audio signal so that, for instance, in the case that the sonic input is a voice input, a server arranged with voice process-

ing capabilities may be able to interpret the voice input and perform a function associated with the voice input.

[0113] The functions of the example process shown in FIG. 8 will now be described in more detail.

[0114] Starting at **802**, a set of signal measures corresponding to audio signals processed based on a first set of audio processing algorithms may be received. The playback device, controller device, and/or NMD of the media playback system may each receive one or more audio signals. A first set of audio processing algorithms may be applied to an audio signal received by a device to improve a signal to noise ratio of the audio signal. The first set of audio algorithms may be the echo cancellation method, beamforming method and/or subtraction of known signal method for a particular resolution. For example, the first set of audio processing algorithms may process impulse responses in a certain window size, e.g., 100 ms, or a certain angular interval of an angular range, e.g., 20 degrees over a 100 degree range. In some embodiments, the window and/or angular interval size that is processed may be limited by available processing power of the playback device, controller device, NMD, or computing device that processes the audio signal. As a result of the processing, one or more signal measures may be associated with each device. The signal measure may be a signal to noise ratio also determined by the playback device, controller device, NMD, or computing device the processed audio signal. The one or more signal measures from each device in the media playback system may define a set of signal measures. For example, the set of signal measures may include the signal to noise ratio associated with a microphone array of a device or the signal to noise ratio associated with receiving an audio signal in a certain direction.

[0115] At **804**, a plurality of signal measures in the set of signal measures may be identified. For example, the plurality of signal measures may be those signal measures, e.g., signal to noise ratio, which are the highest and/or those signal measures which are the lowest.

[0116] Then, at **806**, the audio signals corresponding to the identified plurality of signal measures may be processed by one or more devices in the media playback system so as to improve a signal measure of each of the audio signals. The audio signals may be processed based on a second set of audio processing algorithms.

[0117] The audio signal may be processed based on the second set of audio processing algorithms to improve a signal to noise ratio. The second set of audio processing algorithms may be one or more of the echo cancellation algorithm, beamforming algorithm, or known signal subtraction algorithm, for instance, performed with a higher resolution. The higher resolution may be, for example, processing impulse responses in a larger window size, e.g., 200 ms vs. 100 ms as compared to the first set of audio processing algorithms, a smaller angular interval, e.g., 5 degree intervals vs. 20 degree intervals as compared to the first set of audio processing algorithms, or a larger angular range, e.g., a 200 degree range vs. a 100 degree range as compared to the first set of audio processing algorithms.

[0118] The devices in the media playback system have one or more processors. The one or more processors may have a maximum computational power. The maximum computational power is the power available to perform functions associated with device. In the case of the controller device, the maximum computational power may be characterized as

available clock cycles to process and playback the audio signal control the playback devices. In the case of the server, the maximum computational power may be characterized as available clock cycles to source audio content to the playback devices. In the case of the playback device, the maximum computational power may be characterized as available clock cycles to play back audio content. The spare computational power may be that computational power beyond what may be needed to perform functions of the device, such as to play back the audio in the case of a playback device or control playback devices in the case of a controller device.

[0119] The higher resolution processing requires more computational power than the first set of audio processing algorithms. In this regard, the audio signals may be processed in a distributed manner across one or more devices in the media playback system based on the spare computational power available of a device to improve the signal to noise ratio beyond that of the first set of audio processing algorithms. By using the spare computational power, performance of the media playback system does not degrade with the additional processing associated with improving the signal to noise ratio of the audio signal. The audio signals may be distributed based on other criteria as well such as a speed of a processor of a device.

[0120] At **808**, the processed audio signals may be combined into a combined audio signal. In some embodiments, the combined audio signal may be provided to the server to recover the sonic input of the audio signal.

[0121] FIG. 9 is a flow chart **900** of functions that describes in more detail the functions recited in FIG. 8 that may be performed in the distributed processing described in FIG. 8. In embodiments, these functions may be performed by the computing device but could be performed by a playback device, controller, and/or NMD.

[0122] At **902**, the signal measures corresponding to the audio signals processed by devices in the media playback system may be received. For example, the playback device, NMD, and controller device may apply an audio processing algorithms to the audio signal or audio signals that are received by the device. The audio processing algorithm that is applied may be based on a first set of audio processing algorithms. In one example, the computing device may have a network interface and communication links that communicatively couple the computing device to the playback device, NMD, and controller device to receive the signal measure or signal measures that is determined by each device. In another example, the computing device instead of the device which receives the audio signal may receive the audio signal from a device, apply the audio processing algorithms and/or determine a signal measure. Other arrangements are also possible.

[0123] At **904**, the signal measures may be stored in memory. The computing device may receive for each signal measure an indication of the microphone array of the device associated with the signal measure, an indication of the device associated with the signal measure, and/or an indication of a direction associated with the signal measure. The signal measures stored in memory may be further associated with one or more of these indications.

[0124] FIG. 10 illustrates various examples of storing the signal measures in memory. In embodiments, the signal measures may be stored in the form a table. If each device in the media playback system has one microphone array, the

signal measures may be stored in table **1002** which identifies the signal to noise ratio for each device/microphone array. The table **1002** may be a two-dimensional matrix with each row having a signal to noise ratio and each column identifying the device/microphone array. If a device in the media playback system has one or more microphone arrays, then the signal measures may be stored in a table **1004** which identifies the signal to noise ratio for each microphone array on each device. The table **1004** may be a two-dimensional matrix with each row identifying the signal to noise ratios for each microphone array. If the signal to noise ratio is directional, e.g., determined by a beamforming algorithm, then the signal measure may be stored in a table **1006**, e.g., two-dimensional matrix, which identifies the signal to ratio for a particular direction. The table could also have a third dimension which identifies the particular device or microphone array associated with the signal to noise ratio for a direction and/or microphone array, rather than included in one of the two dimensions of the table. The table may take other forms as well depending on the arrangement of the devices in the media playback system and based on the processing algorithms used to determine the signal to noise ratio.

[0125] The table may also be sorted such that the first entry in the table may identify the highest signal measure, e.g., signal to noise ratio, for the audio signal received by a microphone array and the last entry may identify the lowest signal measure, e.g., signal to noise ratio, for the audio signal received by a microphone array. In the case of the example tables **1002-1006** of FIG. 10, SNR A may represent a highest signal to noise measure and SNR F may represent a lowest signal to noise measure. The table, and for this matter how the signal measures are stored in memory, may take other forms as well depending on the arrangement of the devices in the media playback system and based on the processing algorithms used to determine the signal measure. For example, the table may also be sorted based on the signal to noise ratios meeting a threshold level.

[0126] At **906**, the computing device may determine the spare computational power of the devices in the media playback system. Each device may indicate its spare computational power to a given device, such as a playback device, controller device, or server. In one example, the media playback may define a state variable indicative of an amount of spare computational power associated with a device. This state variable may be periodically updated and made available to the devices in the media playback system. In some embodiments, the state variable may take the form of a flag which indicates that it has a spare computational power.

[0127] Various types of flags may be set depending on an amount of spare computational power available. The flag may take the form of one or more bits that are set on the device or some other device to indicate that the device has spare computational power. For instance, "000" may indicate that the playback device has 50K clock cycles of computational power and "111" may indicate that the playback device has 1000K clock cycles of computational power. Based on the state variable, a given device, e.g., computing device, in the media playback system may obtain the spare computational power for each device and generate a table that identifies for each device its spare processing power. For example, the given device may read the bits

associated with the flag to determine the spare computational power associated with a particular device in the media playback system.

[0128] At **908**, an indication of the spare computational power of the devices may be stored in memory. The spare computational power may be further associated with the indication of the device that has the spare computational power.

[0129] FIG. 10 illustrates an example of storing the computational power in memory. The computational power may be stored in the form a table **1008**. The table **1008** may identify a spare computational power and a device in the media playback system having the spare computational power. Further, the table may be ordered such that a first entry in the table identifies a device with a highest spare computational power in the media playback system and a last entry in the table identifies a device with a lowest spare computational power in the media playback system. In this regard, table **1008** indicates that device **5** has the highest spare computational power of 8 units and device **1** has the lowest spare computational power of 2 units. The units may represent a certain amount of available clock cycles for a processor. The table may store indications other than spare computational power as well so long as spare computational power may be determined from the stored indication.

[0130] At **910**, processing tasks are assigned to the devices identified in the table determined at **908** so as to improve the signal to noise ratio of the processed audio signals. The processing tasks may be associated with a second set of audio processing algorithms, and may include one or more of a higher resolution echo cancellation, beamforming method, and/or subtraction of known signal method. The echo cancellation method and the subtraction of known signal methods may be higher resolution because a longer impulse response of the audio signal is processed as compared the signal measures processed with the first set of signal improvement algorithms. The processing over a longer impulse results in an improved identification and cancellation of echoes and noise. The beamforming may be higher resolution because the audio signal is processed in smaller angular intervals and/or over a greater number of directions. For example, the audio signal is processed at 5 degree intervals rather than 20 degree intervals for a 200 degree angular range rather than a 100 degree angular range. Other arrangements are also possible.

[0131] The processing tasks may be assigned to devices based on available spare processing power available in the media playback system. The echo cancellation and beamforming may require a certain computational power to be performed. Further, the computational power for performing echo cancellation may be less than that for performing beamforming to improve a signal to noise ratio. Accordingly, processing tasks may be assigned based on what spare computational power is available on a device (e.g., a threshold level) and the computational power needed for a processing task. For example, using table **1008**, the processing tasks requiring the most computational power may be assigned to the device with highest available spare processing power, and then the processing task requiring the next most computational power may be assigned to the device with the next highest available spare processing power etc. As another example, processing tasks associated with only the echo cancellation algorithm may be assigned to all of the devices in the media playback system if the spare compu-

tational power across all device is low but enough to support echo cancellation. As yet another example, processing tasks associated with both the beamforming algorithm and echo cancellation may be assigned if the spare computational power across all device high and enough to support both algorithms. In yet another example, some devices may be assigned a processing task of echo cancellation and other devices may be assigned a processing task of beamforming depending on each individual spare processing power. Other arrangements are also possible.

[0132] In some embodiments, a total spare processing power available (e.g., sum of spare processing power for each device) may be less than what is needed to process all of the audio signals that are received by the devices in the media playback system with desired processing algorithms. In this situation, the processing tasks may be assigned based on goals as a result of the audio signal processing. For example, a decision may be made that a high signal to noise ratio is desired for the audio signals that are received from some of the devices. If a high signal to noise ratio is desired, then processing tasks such as both the beamforming algorithm and echo cancellation may be assigned to the one or more devices. On the other hand, a decision may be made that a lower signal to noise ratio is acceptable so that audio signals that are received from all or many of the devices are processed. If the lower signal to noise ratio is acceptable, then processing tasks that use low computational power such as only echo cancellation may be assigned to the one or more devices.

[0133] The processing tasks may be assigned until the spare computational resources is exhausted, or some threshold level of spare computational resources remain for a device or across all devices. Alternatively, the processing tasks may be assigned across the devices so that the spare computational power is reduced across all devices in proportion. Other arrangements are also possible.

[0134] At **912**, certain of the audio signals identified by corresponding signal measures may be processed. The processing may be based on the processing tasks assigned to the devices to result in improved audio signals. For example, the audio signal for the device, microphone array, or direction of the microphone array that has the highest signal to noise ratio as defined by the table of signal to noise ratios may be assigned to the device with the highest spare processing power for processing. Then, the audio signal associated with the next highest signal to noise ratio may be assigned to the device with the next highest signal to noise ratio for processing until all desired audio signals are assigned to the devices associated with processing tasks. By assigning processing tasks in this manner, the overall performance of the media playback device does not degrade because the processing is performed based on spare processing power and not processing power which would otherwise be used to play back audio.

[0135] Other arrangements are also possible for assigning the audio signals to be processed. For instance, a user may specify that certain audio signals may be processed based on knowledge of a relationship between the audio source and microphone array. For instance, if it is known that the sonic input is received directly the microphone array, then the audio signal should be processed regardless of the actual signal to noise ratio of the audio signal. Similarly, if it is known, that if the sonic input is received indirectly by the

microphone array, then the audio signal should not be processed further regardless of the signal to noise ratio of the audio signal.

[0136] The audio signals processed by each device result in an improved audio signal with a higher signal to noise ratio than what was determined by the first set of audio processing algorithms. The improved audio signal may also be weighted based on a confidence or likelihood that the improved audio signal accurately represents the sonic input. For example, the improved audio associated with a certain direction may be weighed more heavily than the improved audio associated with another direction if the likelihood is higher that the sonic input is coming from the certain directions. As another example, the improved audio signal of one device may be weighted heavier than the improved audio signals of another device if one device is closer to the sonic input than the other device. Other arrangements are also possible.

[0137] At **914**, the improved audio signals (with or without weighing) may be combined to form a combined audio signal. By combining the improved audio signals, noise is cancelled resulting in a combined audio signal with a higher signal to noise ratio than any of the improved audio signals making up the combined audio signal. At **916**, this combined audio signal may be then passed to a computing device such as a server. In the event that the audio signal has a voice input, the computing device may attempt to interpret the voice input to determine a function associated with the voice input.

[0138] Methods and the other process disclosed herein may include one or more operations, functions, or actions. Although the blocks are illustrated in sequential order, these blocks may also be performed in parallel, and/or in a different order than those described herein. Also, the various blocks may be combined into fewer blocks, divided into additional blocks, and/or removed based upon the desired implementation.

[0139] In addition, for the methods and other processes and methods disclosed herein, the flowchart shows functionality and operation of one possible implementation of present embodiments. In this regard, each block may represent a module, a segment, or a portion of program code, which includes one or more instructions executable by a processor for implementing specific logical functions or steps in the process. The program code may be stored on any type of computer readable medium, for example, such as a storage device including a disk or hard drive. The computer readable medium may include non-transitory computer readable medium, for example, such as computer-readable media that stores data for short periods of time like register memory, processor cache and Random Access Memory (RAM). The computer readable medium may also include non-transitory media, such as secondary or persistent long term storage, like read only memory (ROM), optical or magnetic disks, compact-disc read only memory (CD-ROM), for example. The computer readable media may also be any other volatile or non-volatile storage systems. The computer readable medium may be considered a computer readable storage medium, for example, or a tangible storage device. In addition, each block in the figures may represent circuitry that is wired to perform the specific logical functions in the process.

IV. Conclusion

[0140] The description above discloses, among other things, various example systems, methods, apparatus, and articles of manufacture including, among other components, firmware and/or software executed on hardware. It is understood that such examples are merely illustrative and should not be considered as limiting. For example, it is contemplated that any or all of the firmware, hardware, and/or software aspects or components can be embodied exclusively in hardware, exclusively in software, exclusively in firmware, or in any combination of hardware, software, and/or firmware. Accordingly, the examples provided are not the only way(s) to implement such systems, methods, apparatus, and/or articles of manufacture.

[0141] Additionally, references herein to “embodiment” means that a particular feature, structure, or characteristic described in connection with the embodiment can be included in at least one example embodiment of an invention. The appearances of this phrase in various places in the specification are not necessarily all referring to the same embodiment, nor are separate or alternative embodiments mutually exclusive of other embodiments. As such, the embodiments described herein, explicitly and implicitly understood by one skilled in the art, can be combined with other embodiments.

[0142] The specification is presented largely in terms of illustrative environments, systems, procedures, steps, logic blocks, processing, and other symbolic representations that directly or indirectly resemble the operations of data processing devices coupled to networks. These process descriptions and representations are typically used by those skilled in the art to most effectively convey the substance of their work to others skilled in the art. Numerous specific details are set forth to provide a thorough understanding of the present disclosure. However, it is understood to those skilled in the art that certain embodiments of the present disclosure can be practiced without certain, specific details. In other instances, well known methods, procedures, components, and circuitry have not been described in detail to avoid unnecessarily obscuring aspects of the embodiments. Accordingly, the scope of the present disclosure is defined by the appended claims rather than the foregoing description of embodiments.

[0143] When any of the appended claims are read to cover a purely software and/or firmware implementation, at least one of the elements in at least one example is hereby expressly defined to include a tangible, non-transitory medium such as a memory, DVD, CD, Blu-ray, and so on, storing the software and/or firmware.

I claim:

1. A media system comprising a first playback device and a second playback device, the media system comprising:
 - the first playback device comprising:
 - one or more microphones;
 - a network interface;
 - a processor;
 - a non-transitory computer-readable medium;
 - program instructions stored on the non-transitory computer-readable medium that, when executed by the processor, cause the first playback device to perform functions comprising:
 - receiving an indication of an available amount of computational power of the second playback device; and

- based on the received indication of the available amount of computational power of the second playback device, sending, to the second playback device, a set of audio signals received by the one or more microphones of the first playback device, wherein the set of audio signals includes at least one voice input;

the second playback device comprising:

- a network interface;
 - a processor;
 - a non-transitory computer-readable medium;
 - program instructions stored on the non-transitory computer-readable medium that, when executed by the processor, cause the second playback device to perform functions comprising:
 - receiving, from the first playback device, the set of audio signals received by the one or more microphones of the first playback device;
 - processing the set of audio signals using a first set of audio processing algorithms to determine a set of signal measures corresponding to the set of audio signals;
 - based on the set of signal measures, identifying, from the set of audio signals, at least two audio signals that are to be re-processed using a second set of audio processing algorithms so as to improve the respective signal measures of the at least two audio signals;
 - re-processing the at least two audio signals using the second set of audio processing algorithms;
 - combining the re-processed at least two audio signals into a combined audio signal; and
 - sending the combined audio signal to a network device.
2. The media system of claim 1, wherein the network device comprises a server, the server comprising:
 - a network interface;
 - a processor;
 - a non-transitory computer-readable medium;
 - program instructions stored on the non-transitory computer-readable medium that are executable by the processor to cause the server to perform functions comprising:
 - determining the available amount of computational power of the second playback device; and
 - sending, to the first playback device, the indication of the available amount of computational power of the second playback device.
 3. The media system of claim 1, wherein the second playback device further comprises program instructions stored on the non-transitory computer-readable medium that are executable by the processor to cause the second playback device to perform functions comprising:
 - determining the available amount of computational power of the second playback device; and
 - sending, to the first playback device, the indication of the available amount of computational power of the second playback device.
 4. The media system of claim 1, the second playback device further comprising one or more microphones.
 5. The media system of claim 4, wherein at least a portion of the set of audio signals received by the one or more

microphones of the first playback device is additionally received by the one or more microphones of the second playback device.

6. The media system of claim 1, the media system further comprising a third playback device, and wherein the first playback device further comprises program instructions stored on the non-transitory computer-readable medium that are executable by the processor to cause the first playback device to perform functions comprising:

- receiving an indication of an available amount of computational power of the third playback device;
- comparing the available amount of computational power of the second playback device with the available amount of computational power of the third playback device; and

- based on comparing the available amount of computational power of the second playback device with the available amount of computational power of the third playback device, deciding to send the set of audio signals received by the one or more microphones of the first playback device to the second playback device.

7. The media system of claim 1, wherein each of the first set of audio processing algorithms and the second set of audio processing algorithms comprises at least one of an echo cancellation algorithm or a beamforming algorithm.

8. The media system of claim 1, wherein the first playback device further comprises program instructions stored on the non-transitory computer-readable medium that are executable by the processor to cause the first playback device to perform functions comprising:

- based on the received indication of the available amount of computational power of the second playback device, determining that the available amount of computational power of the second playback device is above a threshold amount of computational power.

9. The media system of claim 1, wherein the at least one voice input comprises at least one command, and wherein the network device comprises a server, the server comprising:

- a network interface;
- a processor;
- a non-transitory computer-readable medium;
- program instructions stored on the non-transitory computer-readable medium that are executable by the processor to cause the server to perform functions comprising:
 - receiving the combined audio signal from the second playback device;
 - based on the combined audio signal, recognizing the at least one command; and
 - transmitting an indication of the recognized at least one command to the first playback device.

10. The media system of claim 1, wherein the at least two audio signals comprise audio signals having signal to noise ratios meeting a threshold amount.

11. The media system of claim 1, wherein a resolution of the first set of audio processing algorithms is lower than a resolution of the second set of audio processing algorithms.

12. The media system of claim 1, wherein a signal measure of the combined audio signal is higher than a respective signal measure of any of the set of audio signals or any of the re-processed at least two audio signals.

13. The media system of claim 1, wherein the signal measure is a signal to noise ratio.

14. The media system of claim 1, wherein the network device is one of the first playback device or a server.

15. A method comprising:

- receiving, by a first playback device from a second playback device, an indication of an available amount of computational power of the second playback device; and

- based on the received indication of the available amount of computational power of the second playback device, sending, from the first playback device to the second playback device, a set of audio signals received by the one or more microphones of the first playback device, wherein the set of audio signals includes at least one voice input;

- receiving, by the second playback device from the first playback device, the set of audio signals received by the one or more microphones of the first playback device;

- processing, by the second playback device, the set of audio signals using a first set of audio processing algorithms to determine a set of signal measures corresponding to the set of audio signals;

- based on the set of signal measures, identifying, by the second playback device from the set of audio signals, at least two audio signals that are to be re-processed using a second set of audio processing algorithms so as to improve the respective signal measures of the at least two audio signals;

- re-processing, by the second playback device, the at least two audio signals using the second set of audio processing algorithms;

- combining, by the second playback device, the re-processed at least two audio signals into a combined audio signal; and

- sending, by the second playback device, the combined audio signal to a network device.

16. The method of claim 15, wherein the network device is one of the first playback device or a server.

17. The method of claim 15, the second playback device further comprising one or more microphones.

18. The method of claim 15, further comprising:

- based on the received indication of the available amount of computational power of the second playback device, determining, by the first playback device, that the available amount of computational power of the second playback device is above a threshold amount of computational power.

19. The method of claim 15, wherein the at least two audio signals comprise audio signals having signal to noise ratios meeting a threshold amount.

20. The method of claim 15, wherein the signal measure is a signal to noise ratio.

* * * * *