



US011999771B2

(12) **United States Patent**
Dower et al.

(10) **Patent No.:** **US 11,999,771 B2**
(45) **Date of Patent:** ***Jun. 4, 2024**

- (54) **IL-7R α yc LIGAND IMMUNOGLOBULIN FUSION PROTEINS**
- (71) Applicant: **MEDIKINE, INC.**, Menlo Park, CA (US)
- (72) Inventors: **William J. Dower**, Menlo Park, CA (US); **Ronald W. Barrett**, Menlo Park, CA (US); **Michael C. Needels**, Menlo Park, CA (US); **Steven E. Cwirla**, Menlo Park, CA (US); **Alice V. Bakker**, Menlo Park, CA (US); **Inkyung Park**, Menlo Park, CA (US)

- (73) Assignee: **Medikine, Inc.**, Menlo Park, CA (US)
- (*) Notice: Subject to any disclaimer, the term of this patent is extended or adjusted under 35 U.S.C. 154(b) by 0 days.

This patent is subject to a terminal disclaimer.

- (21) Appl. No.: **18/061,567**
- (22) Filed: **Dec. 5, 2022**
- (65) **Prior Publication Data**
US 2023/0322880 A1 Oct. 12, 2023

Related U.S. Application Data

- (60) Provisional application No. 63/328,700, filed on Apr. 7, 2022.

- (51) **Int. Cl.**
C07K 14/54 (2006.01)
A61K 38/20 (2006.01)
A61K 38/00 (2006.01)
C07K 7/08 (2006.01)
C07K 14/715 (2006.01)
- (52) **U.S. Cl.**
CPC **C07K 14/5418** (2013.01); **A61K 38/2046** (2013.01); **A61K 38/00** (2013.01); **C07K 7/08** (2013.01); **C07K 14/7155** (2013.01); **C07K 2319/30** (2013.01)

- (58) **Field of Classification Search**
CPC **C07K 14/5418**; **C07K 14/7155**; **C07K 2319/30**; **A61K 38/204**
See application file for complete search history.

- (56) **References Cited**

U.S. PATENT DOCUMENTS

5,635,597 A	6/1997	Barrett et al.
9,861,705 B2	1/2018	Bossard et al.
10,035,836 B1	7/2018	Greve
10,689,417 B2	6/2020	Dower et al.
10,703,776 B2	7/2020	Dower et al.
11,248,030 B2	2/2022	Dower et al.
11,254,729 B2	2/2022	Dower et al.
11,746,139 B2	9/2023	Dower et al.
2003/0166163 A1	9/2003	Gillies
2005/0054054 A1	3/2005	Foss et al.
2006/0141581 A1	6/2006	Gillies et al.
2009/0104218 A1	4/2009	Tettelin et al.

2011/0243887 A1	10/2011	Lauder et al.
2013/0330296 A1	12/2013	Khaled
2017/0327555 A1	11/2017	Greve
2018/0125941 A1	5/2018	Greve
2018/0162919 A1	6/2018	Greve et al.
2018/0362655 A1	12/2018	Wang et al.
2019/0119346 A1	4/2019	Garcia et al.
2019/0153058 A1	5/2019	Greve
2019/0194255 A1	6/2019	Tagaya et al.
2019/0202881 A1	7/2019	Greve
2019/0202882 A1	7/2019	Greve
2020/0040034 A1	2/2020	Dower et al.
2020/0040036 A1	2/2020	Dower et al.
2020/0291066 A1	9/2020	Dower et al.
2020/0291067 A1	9/2020	Dower et al.
2021/0130424 A1	5/2021	Dower et al.
2021/0198336 A1	7/2021	Dower et al.
2021/0253669 A1	8/2021	Dower et al.
2021/0253670 A1	8/2021	Dower et al.
2022/0119465 A1	4/2022	Dower et al.
2022/0119492 A1	4/2022	Dower et al.
2022/0119493 A1	4/2022	Dower et al.
2023/0357358 A1	11/2023	Dower et al.

FOREIGN PATENT DOCUMENTS

JP	2017528444	9/2017
TW	201833137	9/2018
WO	2010/099084	9/2010
WO	2017/068421	4/2017
WO	2017/136818	8/2017
WO	2020/033312 A1	2/2020
WO	2021/092075 A1	5/2021
WO	2021/092081 A1	5/2021
WO	WO-2021122866 A1	6/2021
WO	2021/158619 A1	8/2021
WO	2021/158623 A1	8/2021
WO	2022/098890 A1	5/2022
WO	WO-2023196876 A1	10/2023

OTHER PUBLICATIONS

International Preliminary Report on Patentability for Application No. PCT/US2020/035747, dated Dec. 7, 2021, 11 pages.

International Preliminary Report on Patentability for Application No. PCT/US2020/058963, dated May 10, 2022, 7 pages.

International Preliminary Report on Patentability for Application No. PCT/US2019/045109, dated Feb. 9, 2021, 10 pages.

International Preliminary Report on Patentability for Application No. PCT/US2021/016356, dated Jul. 28, 2022, 7 pages.

International Preliminary Report on Patentability for Application No. PCT/US2021/016361, dated Jul. 28, 2022, 6 pages.

International Preliminary Report on Patentability for Application No. PCT/US2020/058969, dated May 10, 2022, 8 pages.

(Continued)

Primary Examiner — Zachary C Howard

(74) *Attorney, Agent, or Firm* — COOLEY LLP

- (57) **ABSTRACT**

IL-7R α yc ligands and IL-7R α yc IgG-Fc fusion proteins are disclosed. The IL-7R α yc ligands and IL-7R α yc IgG-Fc fusion proteins are IL-7R agonists.

29 Claims, 37 Drawing Sheets

Specification includes a Sequence Listing.

(56)

References Cited

OTHER PUBLICATIONS

International Preliminary Report on Patentability for Application No. PCT/US2021/058085, dated May 8, 2023, 8 pages.

Burtea et al., "Screening for peptides targeted to IL-7Ra for molecular imaging of rheumatoid arthritis synovium", *Arthritis Research & Therapy*, Oct. 2016, vol. 18, No. 1, 230, 19 pages.

Partial International Search for PCT Application No. PCT/US2019/045109, dated Nov. 5, 2019, 17 pages.

International Search Report and Written Opinion for PCT Application No. PCT/US2019/045109, dated Jan. 14, 2020, 20 pages.

International Search Report and Written Opinion for PCT Application No. PCT/US2021/016361, dated Jul. 15, 2021, 12 pages.

International Search Report and Written Opinion for PCT Application No. PCT/US2021/016356, dated Jul. 13, 2021, 12 pages.

International Search Report and Written Opinion for PCT Application No. PCT/US2021/016361, dated Jul. 15, 2021, 12 pages.

International Search Report and written Opinion for PCT Application No. PCT/US2020/058969, dated Apr. 6, 2021, 14 pages.

International Search Report and Written Opinion for PCT Application No. PCT/US2021/058085, dated Jun. 2, 2022, 14 pages.

Betts et al., "Chapter 14: Amino Acid Properties and Consequences of Substitutions, Bioinformatics for Geneticists", 2003, Bames and Gray Eds., 28 pages.

Burtea et al., "Screening for peptides targeted to IL-7Ra for molecular imaging of rheumatoid arthritis synovium", *Arthritis Res Therapy*, Oct. 2016, vol. 18, No. 1, 230, 19 pages.

Chen et al., "Fusion Protein Linkers: Property, Design and Functionality", *Advanced Drug Delivery Reviews*, Oct. 2013, vol. 65, No. 10, pp. 1357-1369.

Dower et al., "MDK/MDK-701: A potent fully efficacious peptidyl agonist of IL-7R $\alpha\gamma$ c, designed with no reference to cytokine or receptor structure and unrelated to IL-7, fused to an FC-domain for PK enhancement", *Journal for ImmunoTherapy of Cancer*, 2020, vol. 8, Issue 3, pp. A341-A342.

Klein et al., "Cergutuzumab amunaleukin (CEA-IL2v), a CEA-targeted IL-2 variant-based immunocytokine for combination cancer immunotherapy: Overcoming limitations of aldeslukin and conventional IL-2-based immunocytokines." *Oncol Immunology*, 2017, vol. 6, No. 3, e1277306, 15 pages.

Levin et al., "Exploiting a natural conformational switch to engineer an interleukin-2 'superkine,'" *Nature*, Apr. 2012, vol. 484, p. 529-533.

McElroy et al., "Structural reorganization of the interleukin-7 signaling complex", *PNAS*, 2012, vol. 109, No. 7, pp. 2503-2508.

Mitra et al., "Interleukin-2 Activity can be Fine-Tuned with Engineered Receptor Signaling Clamps," *Immunity*, May 2015, vol. 42, No. 5, 29 pages.

Moors et al., "Interneukin-7 (IL-7) and IL-7 splice variants affect differentiation of human neural progenitor cells", *Genes and Immunity*, 2010, vol. 11, pp. 11-20.

Pulliam et al., "Common gamma chain cytokines in combinatorial immune strategies against cancer," *Immunology Letters*, 2016, vol. 169, p. 61-72.

Rodriguez et al., "Hypothetical protein EBU92_10635 [Betaproteobacteria bacterium]", Genbank online entry, National Center for Biotechnology Information, retrieved from URL [<https://www.ncbi.nlm.nih.gov/protein/NBO41957.1>] retrieved on Jan. 12, 2020, 2 pages.

Silva et al., "De novo design of potent and selective mimics of IL-2 and IL-15", *Nature*, Jan. 2019, 565(7738), pp. 186-191.

UNIPROTKB Accession No. A0A227JM75, Oct. 25, 2017, retrieved from URL [<https://www.uniprot.org/uniprot/A0A227JM75>], entire document retrieved on Mar. 22, 2021, 5 pages.

UNIPROTKB Accession No. A0A444GHQ1, May 8, 2019, retrieved from URL [<https://www.uniprot.org/uniprot/A0A444GHQ1>], entire document retrieved on Jun. 12, 2021, 3 pages.

UNIPROTKB Accession No. A0A0N1IMW7, Dec. 9, 2015, retrieved from URL [<https://www.uniprot.org/uniprot/A0A0N1IMW7>], entire document retrieved on Jun. 12, 2021, 3 pages.

UNIPROTKB Accession No. A0A2D7IYS8, Apr. 25, 2018, retrieved from URL [<https://www.uniprot.org/uniprot/A0A2D7IYS8>], entire document retrieved on Mar. 19, 2021, 3 pages.

UNIPROTKB Accession No. A0A1D1ZF92, Nov. 30, 2016, retrieved from URL [<https://www.uniprot.org/uniprot/A0A1D1ZF92>], retrieved on Mar. 19, 2021, 3 pages.

Cooper M, et al., "ALong-Acting Pharmacological Grade Interleukin-7 Molecule Logarithmically Accelerates Cart Proliferation, Differentiation, and Tumor Killing", *Biol Blood Marrow Transplant*, 25(3 Suppl), 223, 2019, pp. S163-S164.

International Search Report and Written Opinion for PCT Application No. PCT/US2023/065402, dated Apr. 8, 2023, 14 pages.

Kim, Ji-Hae et al., "Hybrid Fc-fused interleukin-7 induces an inflamed tumor microenvironment and improves the efficacy of cancer immunotherapy," *Clin Transl Immunology*. (2020); 9(9):e1168, 16 pages.

McElroy C A et al., "Structural and Biophysical Studies of the Human IL-7/IL-7R α Complex", *Structure*, 17(1), 2009, pp. 54-65.

NCBI Reference Sequence: NP_000197.1, "cytokine receptor common subunit gamma precursor [*Homo sapiens*]," Nov. 27, 2023 [retrieved online Dec. 9, 2023] https://www.ncbi.nlm.nih.gov/protein/NP_000197.1/, 4 pages.

NCBI Reference Sequence: NP_002176.2: interleukin-7 receptor subunit alpha isoform 1 precursor [*Homo sapiens*], Dec. 25, 2023; [retrieved online Dec. 26, 2023] URL: https://www.ncbi.nlm.nih.gov/protein/NP_002176.2/, 4 pages.

NCBI Reference Sequence: XP_005593949.1: cytokine receptor common subunit gamma [*Macaca fascicularis*], Dec. 8, 2021; ; [retrieved online Dec. 26, 2023] URL: https://www.ncbi.nlm.nih.gov/protein/XP_005593949, 2 pages.

Park, Angie I, et al.; "Abstract 2066: In vitro and in vivo properties of MDK703: An Fc-peptide fusion IL-7R $\alpha\gamma$ c agonist unrelated in structure to IL-7," *Cancer Res* (2022) 82 (12_Supplement):2066, 1 page.

UniProtKB/Swiss-Prot: P16871.3, Interleukin-7 receptor subunit alpha, Nov. 3, 2023, [retrieved online Dec. 27, 2023] URL: <https://www.ncbi.nlm.nih.gov/protein/P16871>, 8 pages.

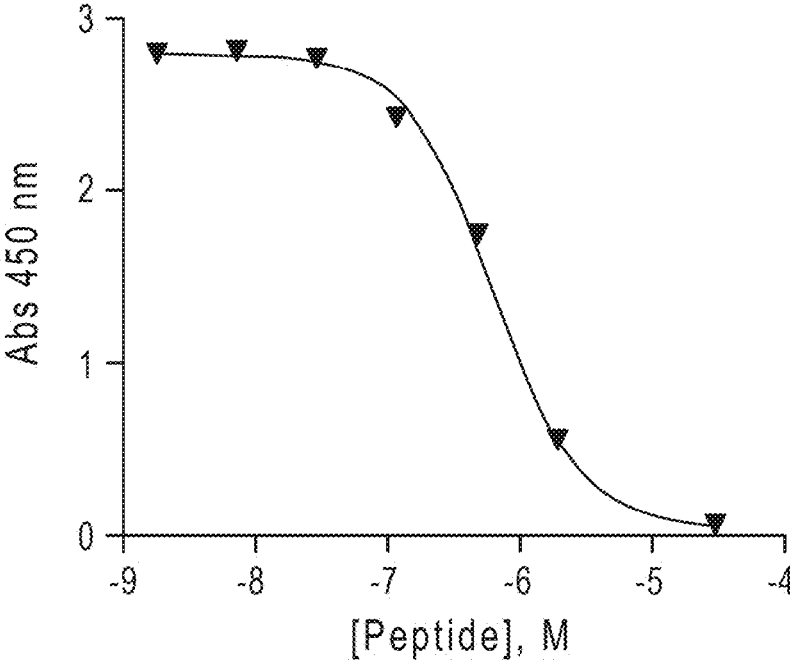

FIG. 1

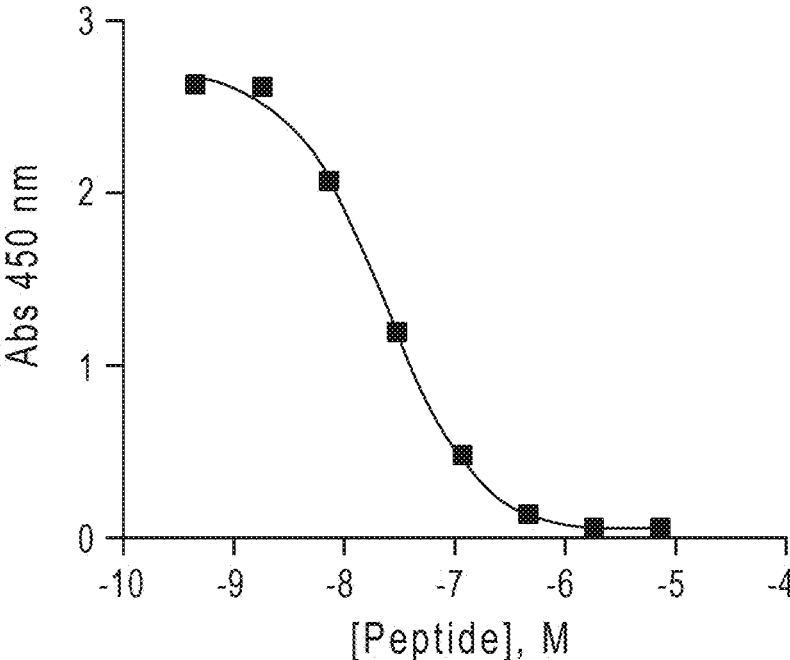

FIG. 2

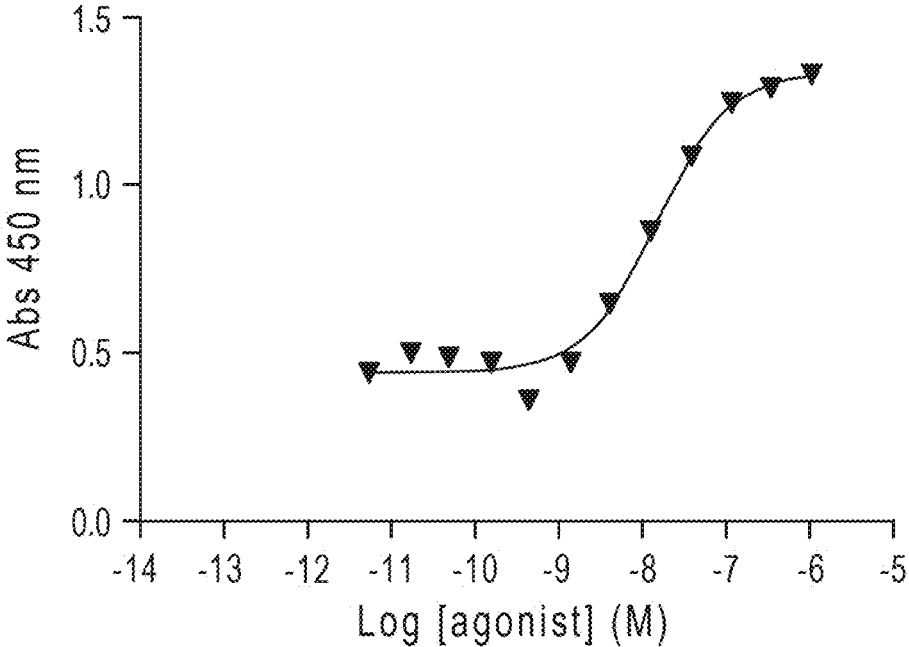

FIG. 3

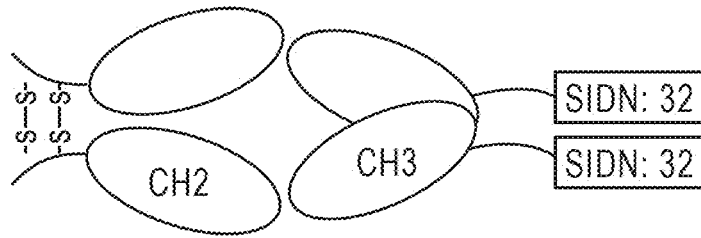

FIG. 4

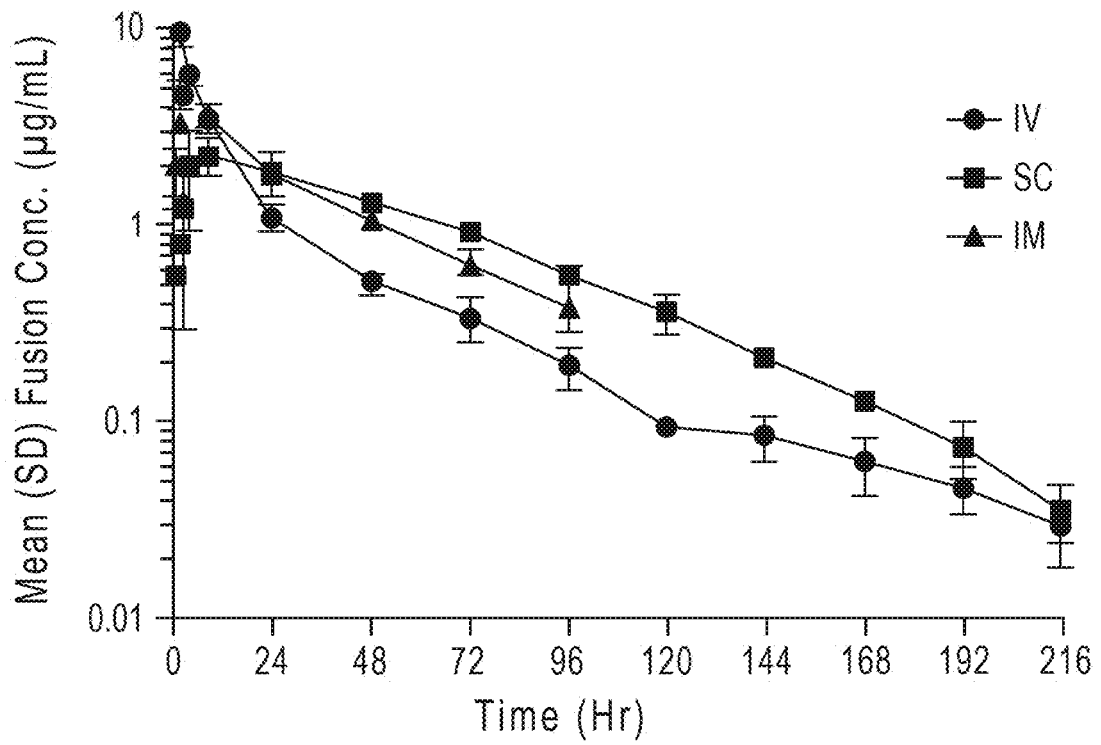

FIG. 5

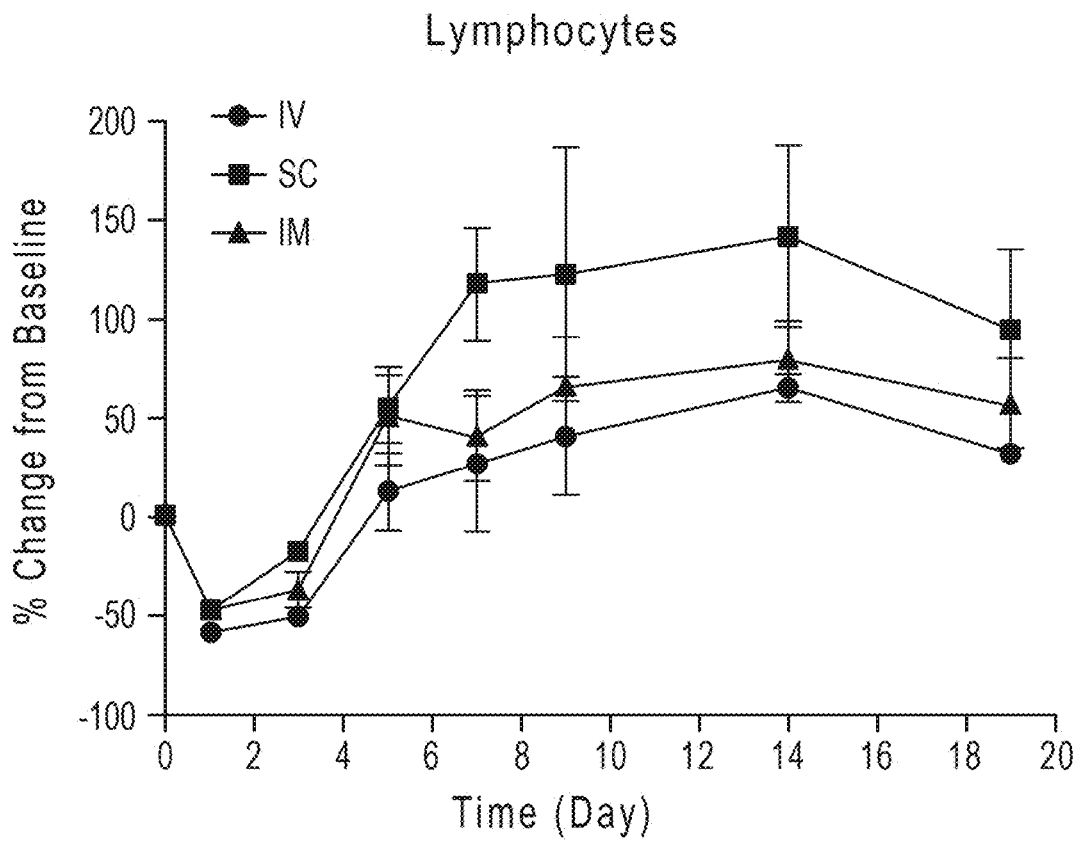

FIG. 6

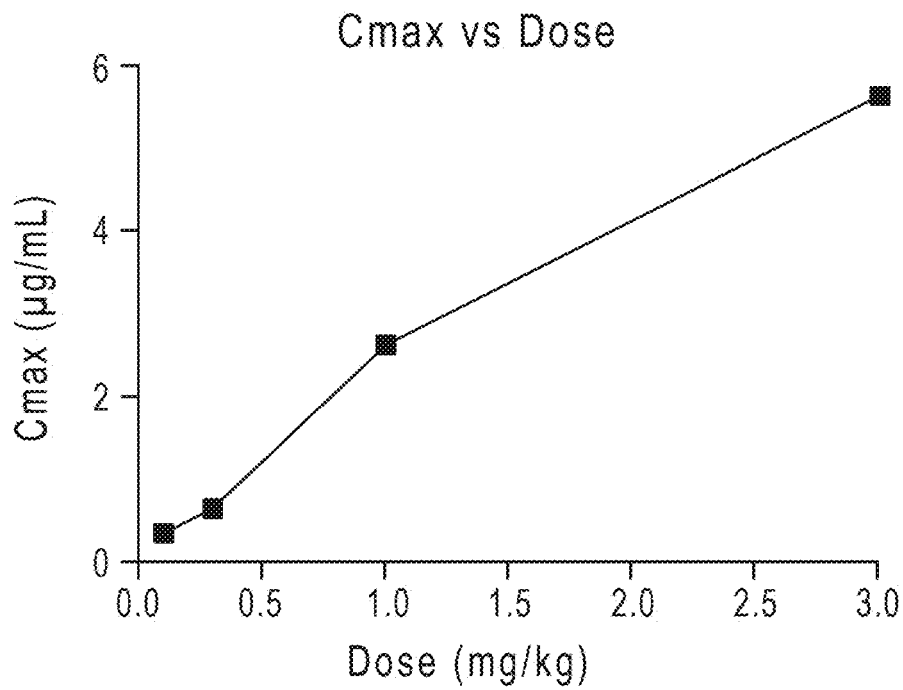

FIG. 7A

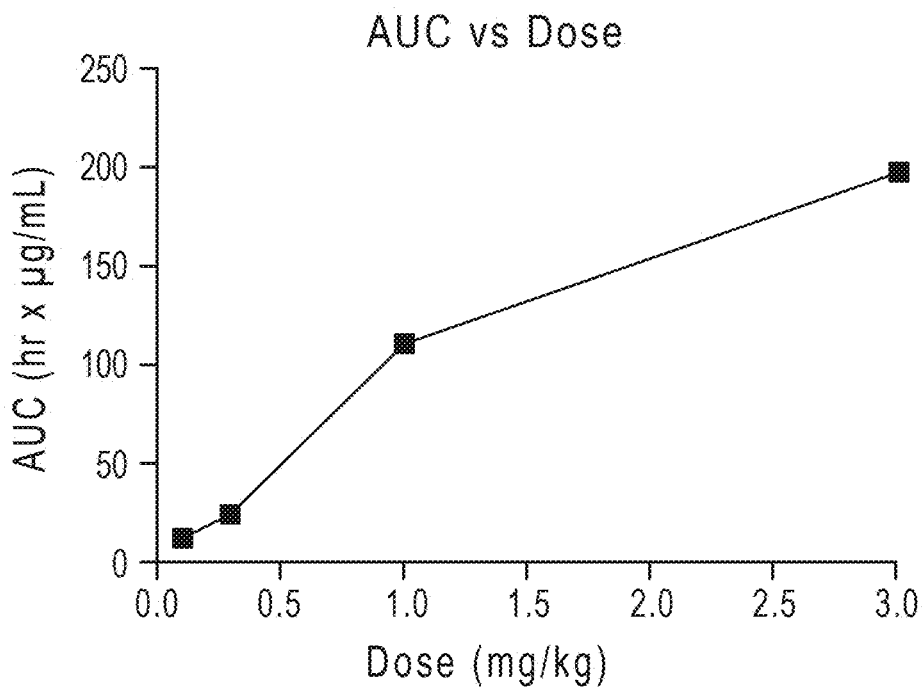

FIG. 7B

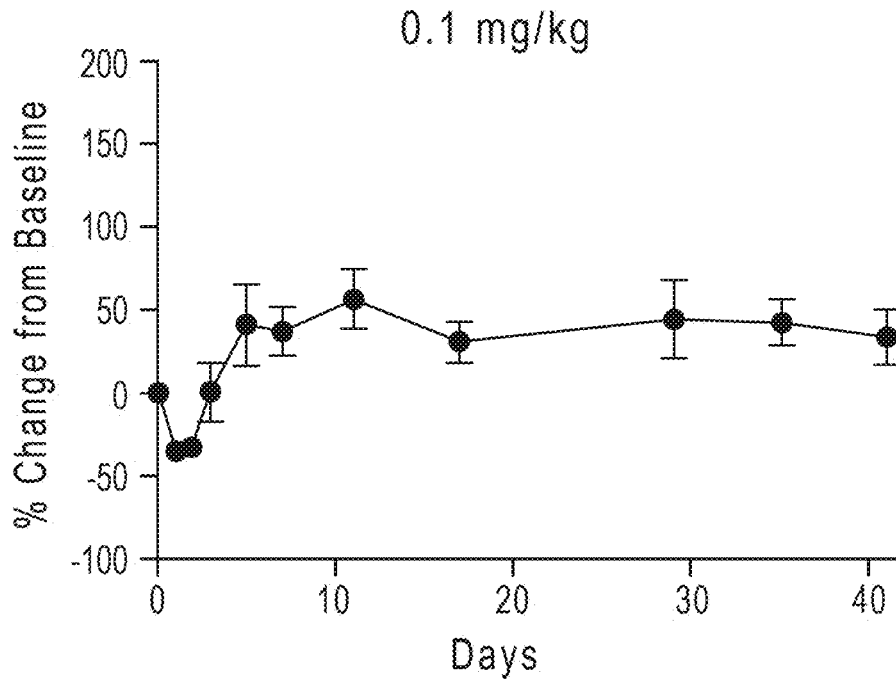

FIG. 8A

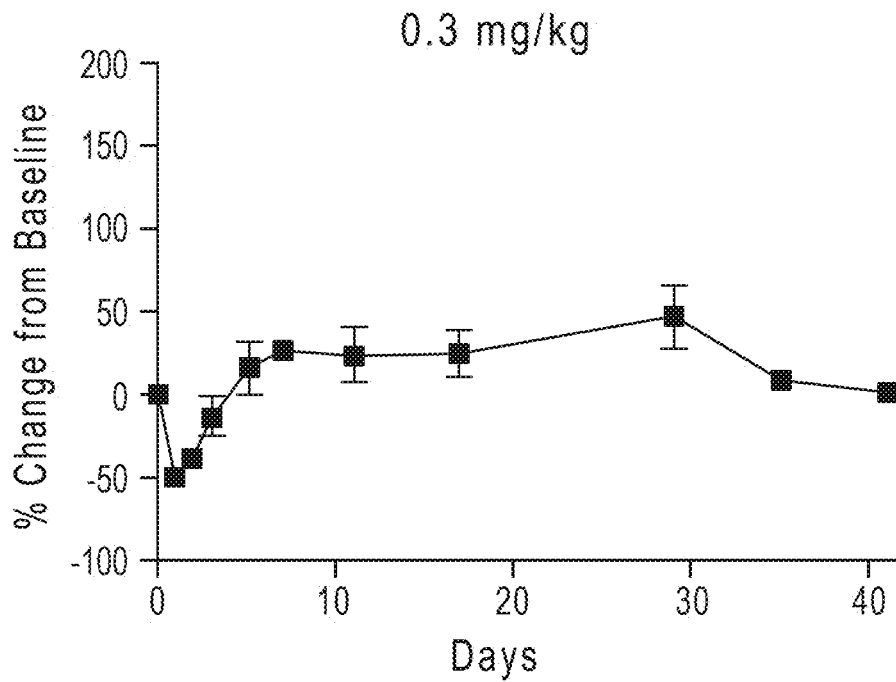

FIG. 8B

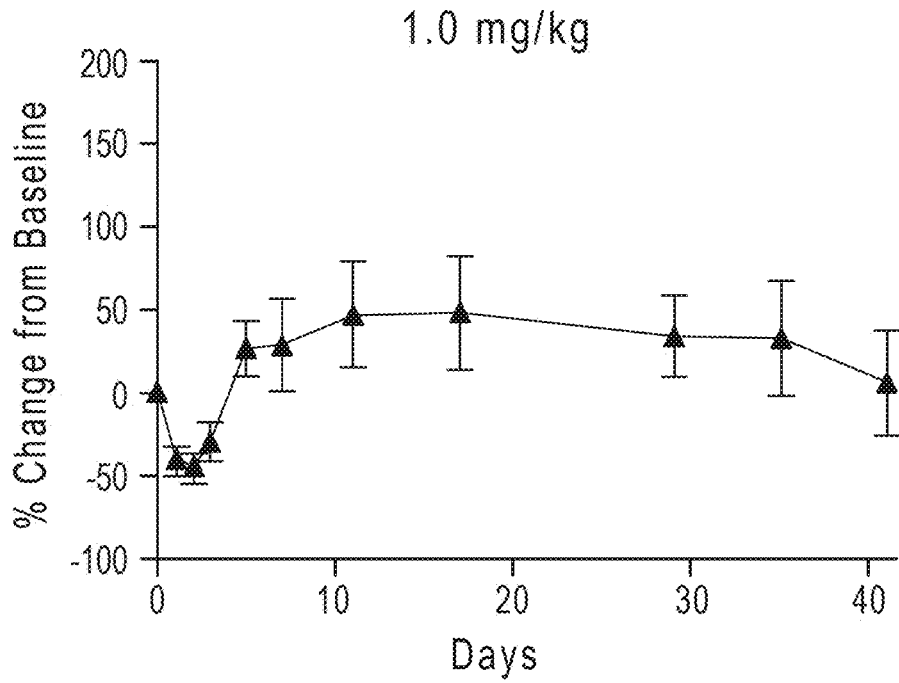

FIG. 8C

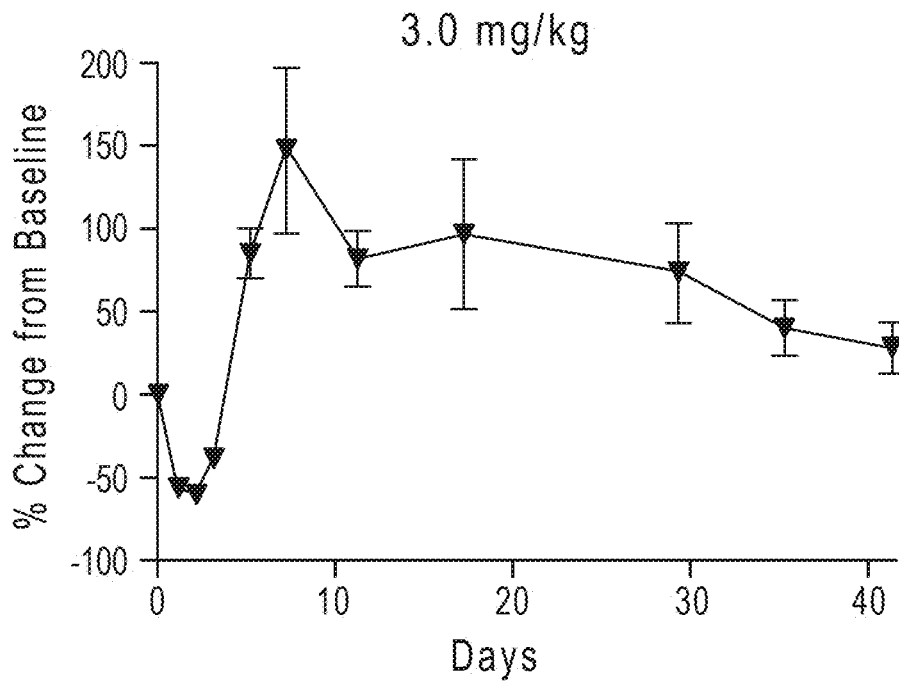

FIG. 8D

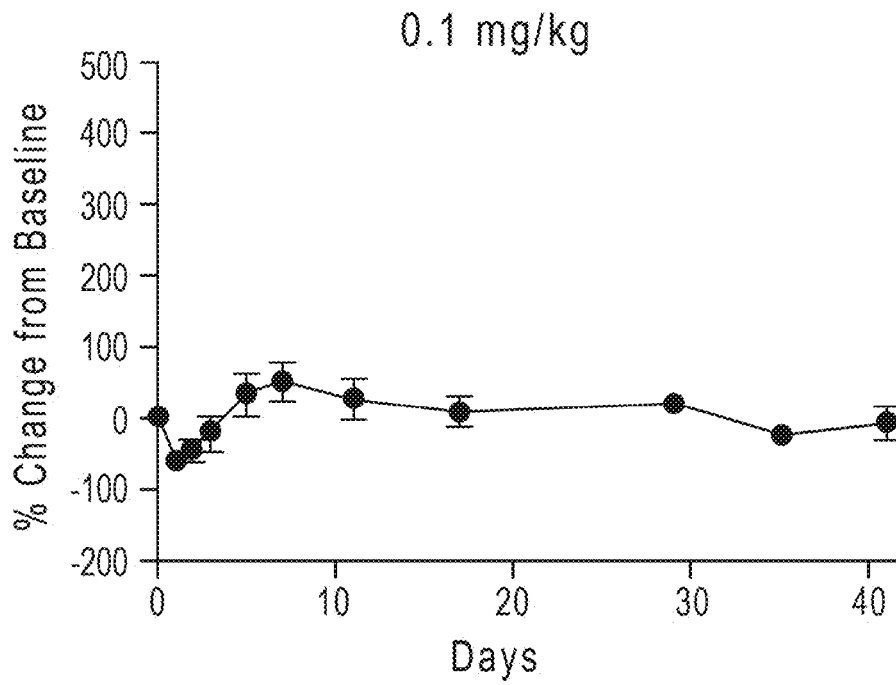

FIG. 9A

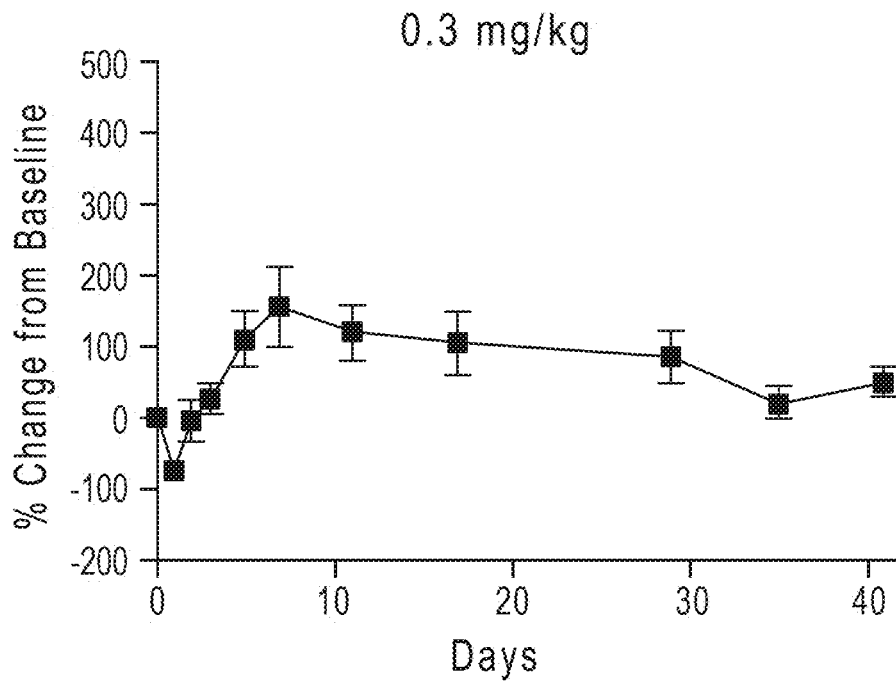

FIG. 9B

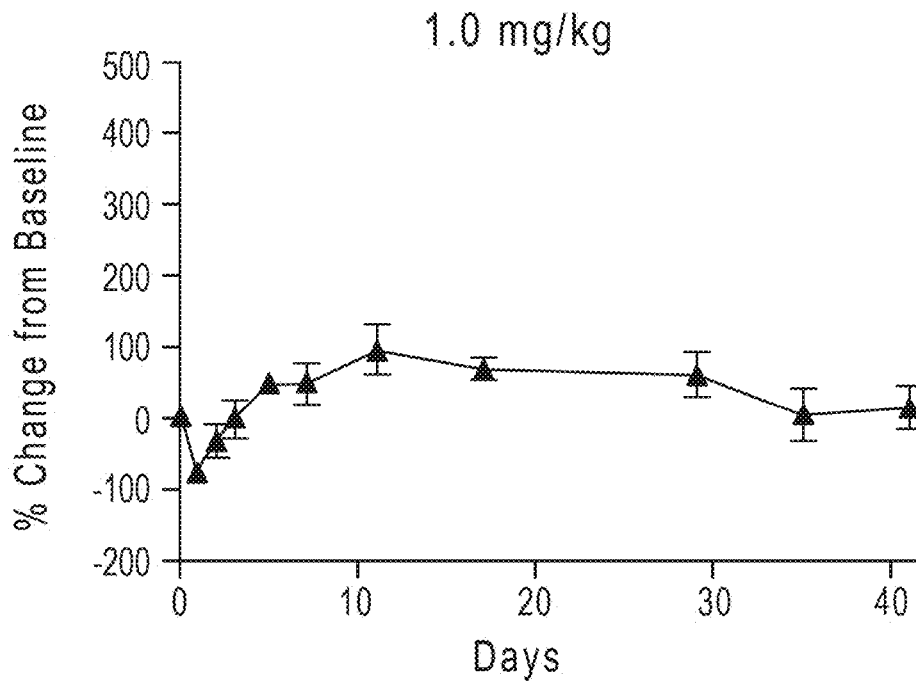

FIG. 9C

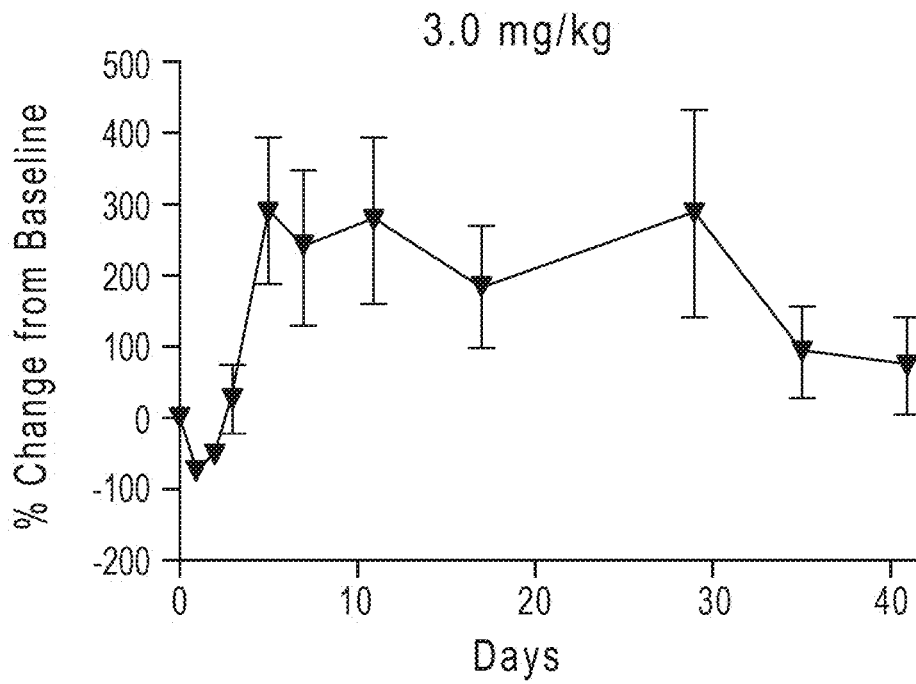

FIG. 9D

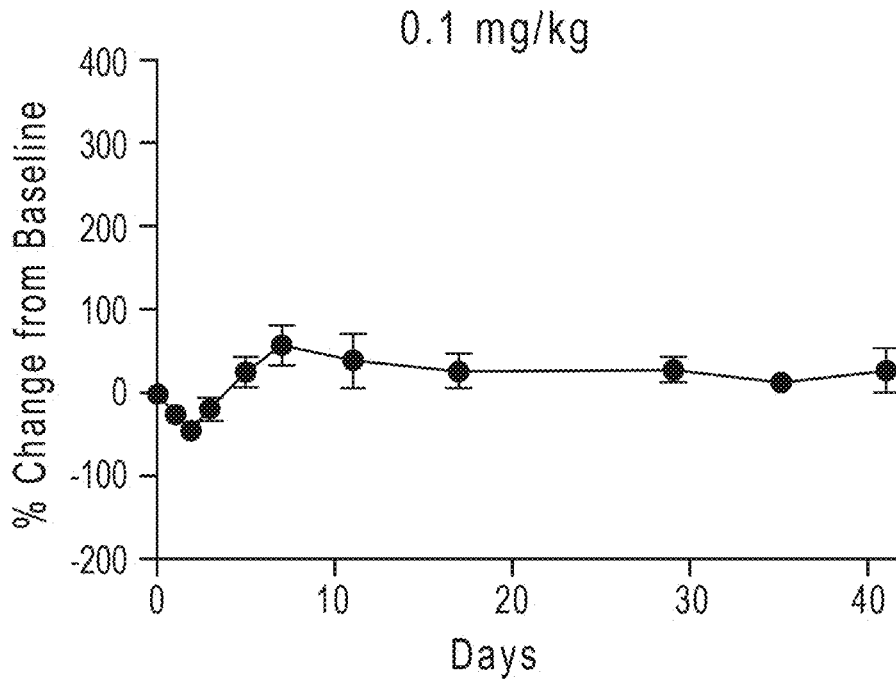

FIG. 10A

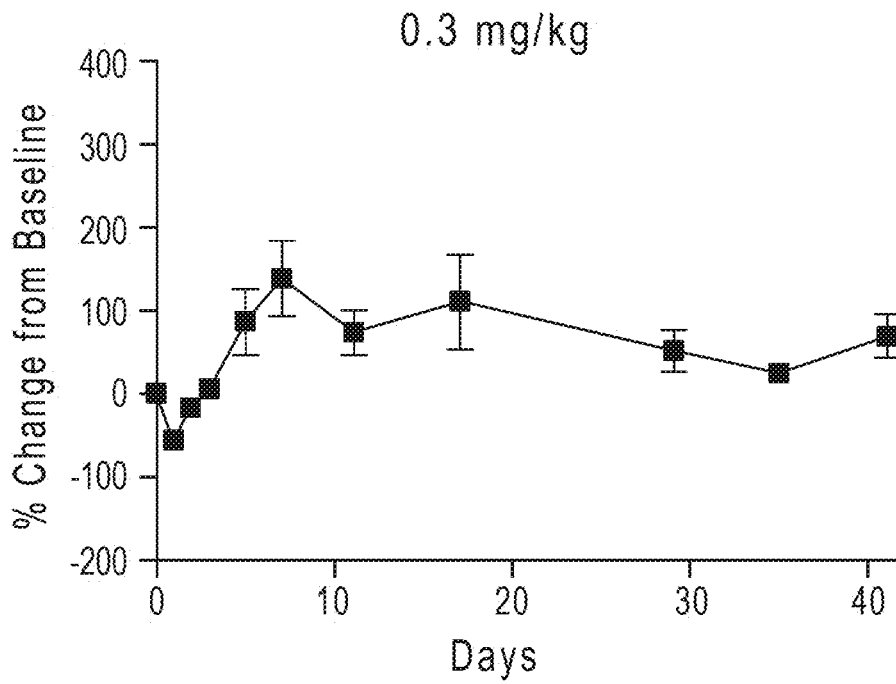

FIG. 10B

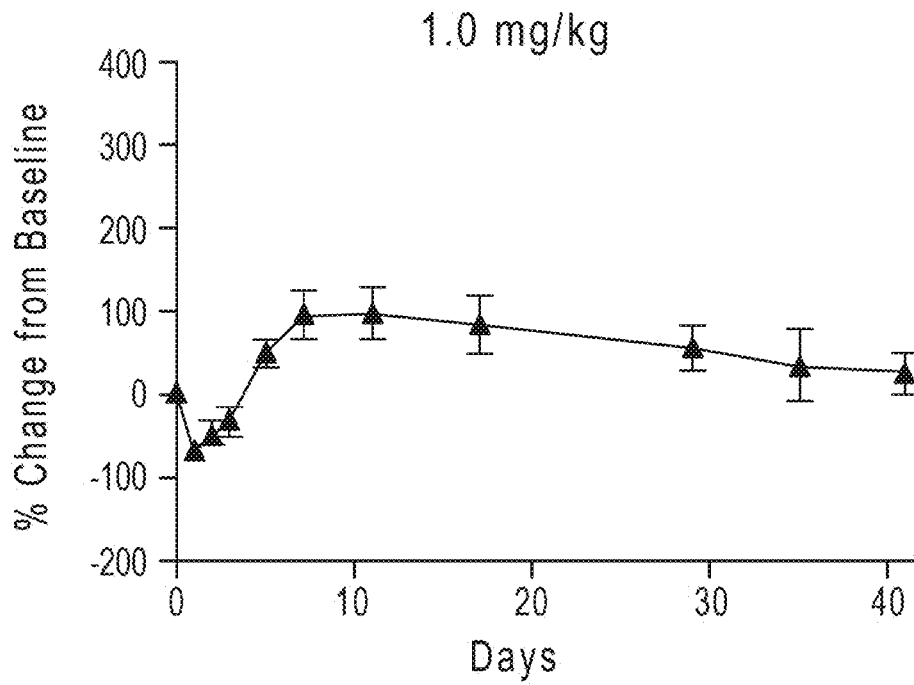

FIG. 10C

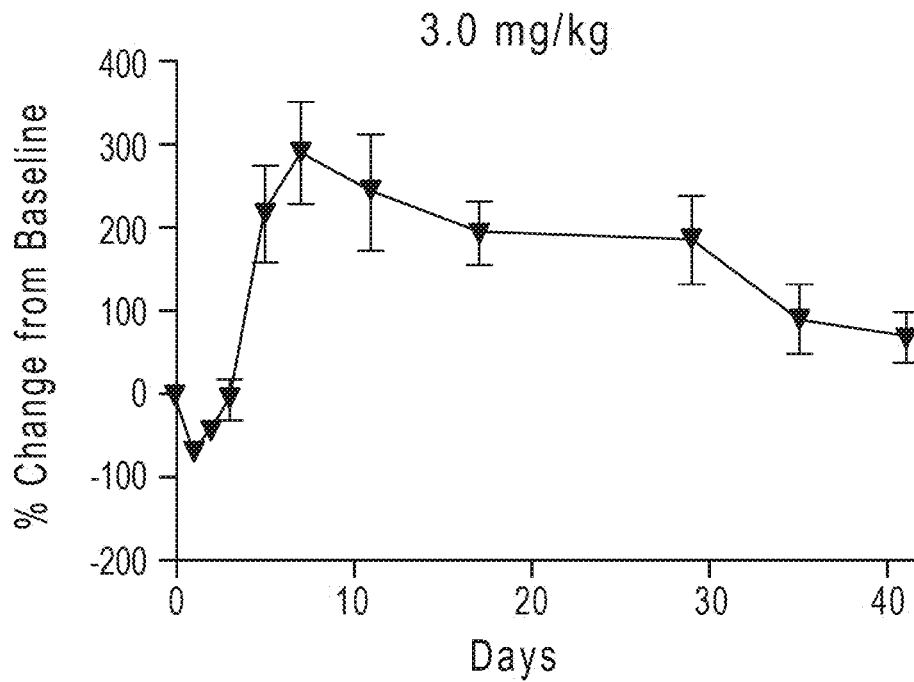

FIG. 10D

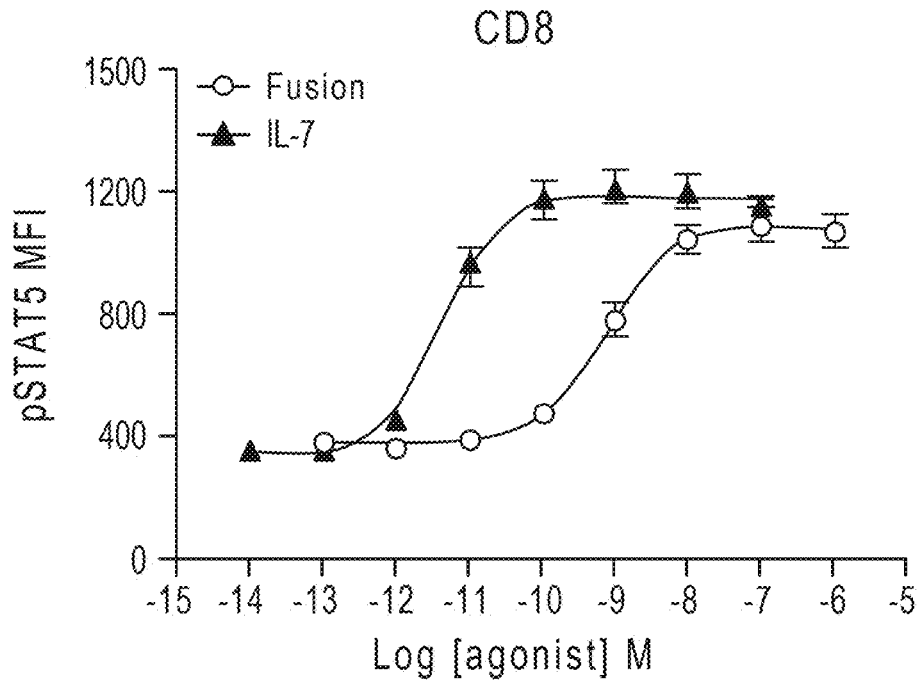

FIG. 11A

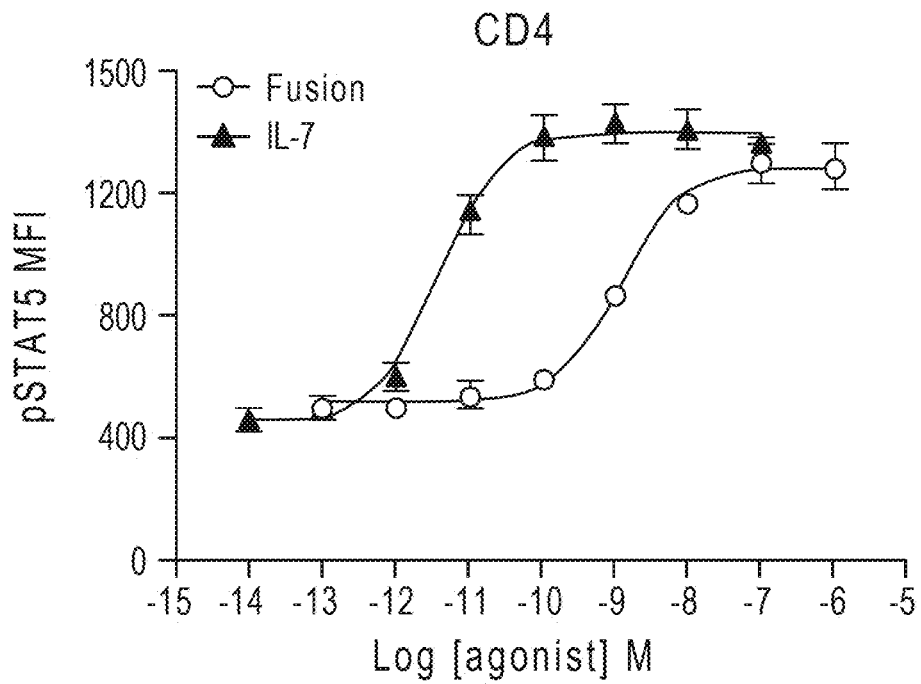

FIG. 11B

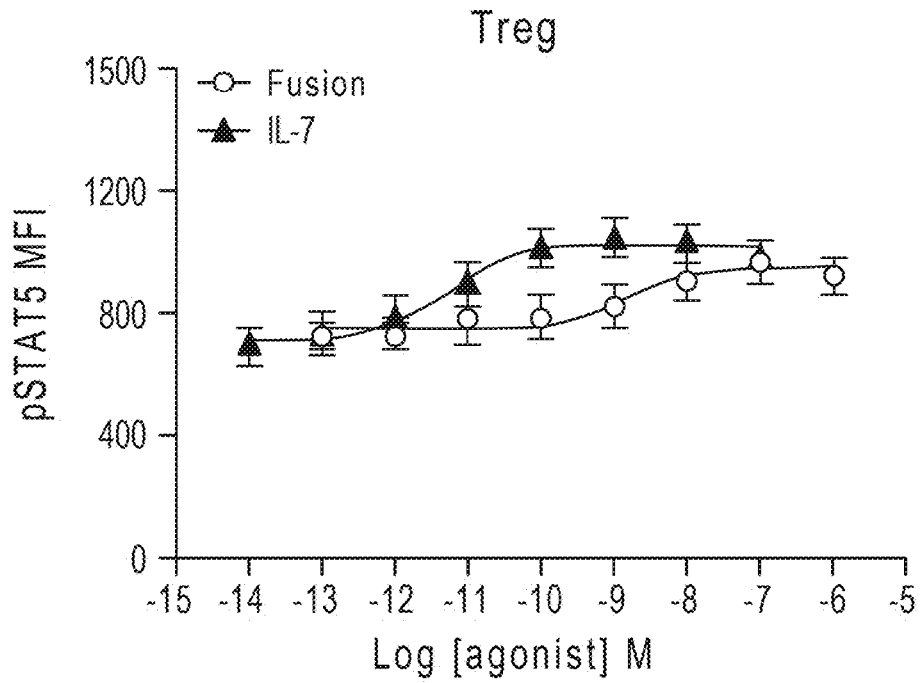

FIG. 11C

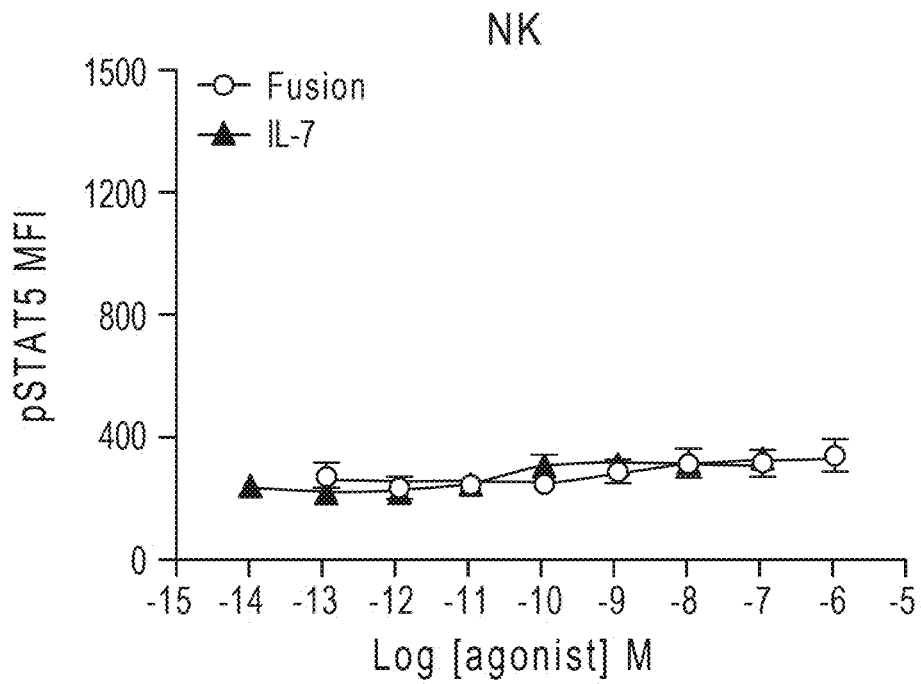

FIG. 11D

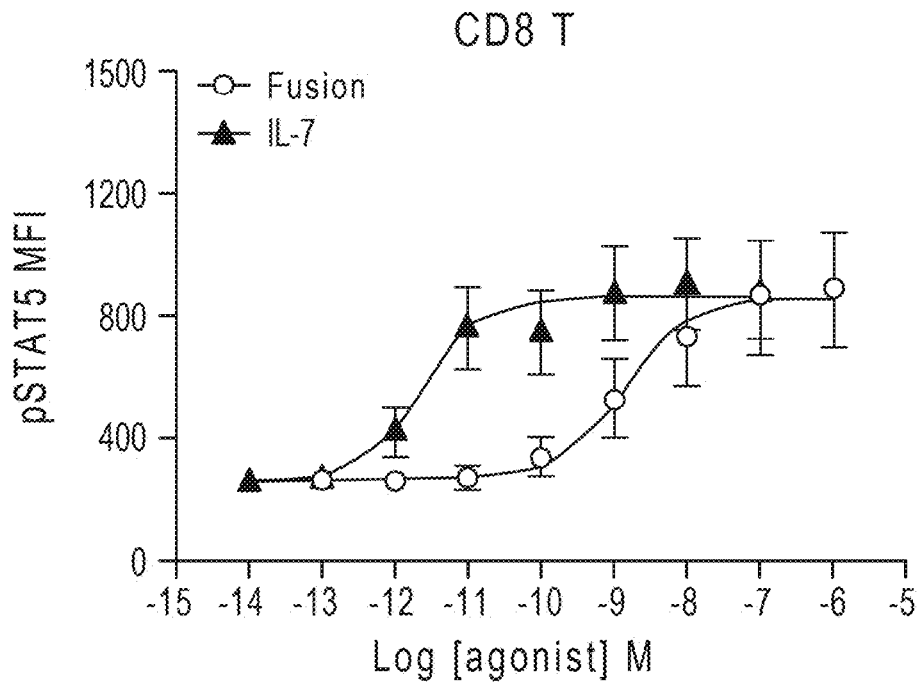

FIG. 11E

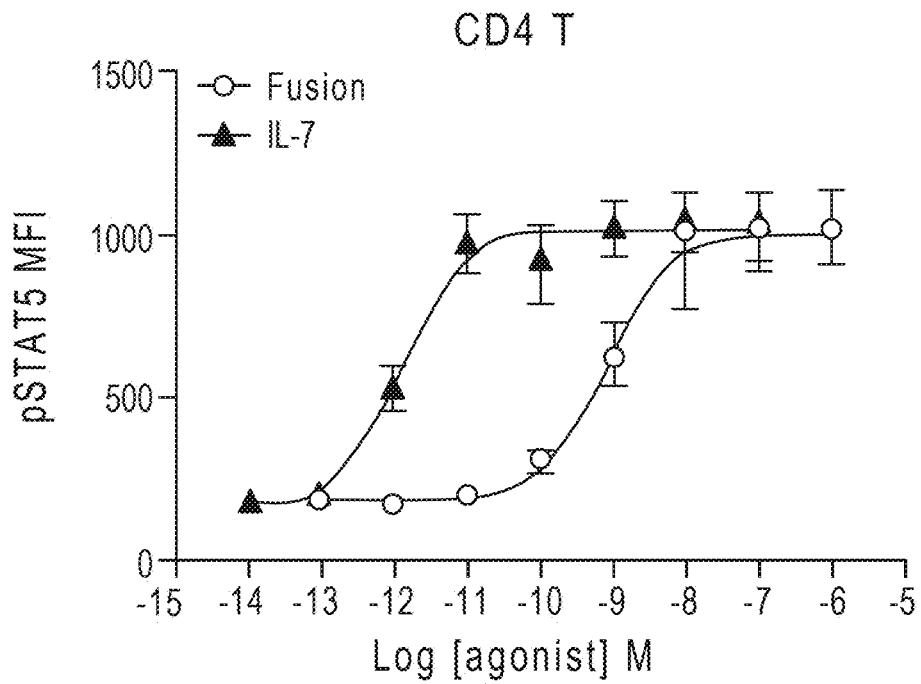

FIG. 11F

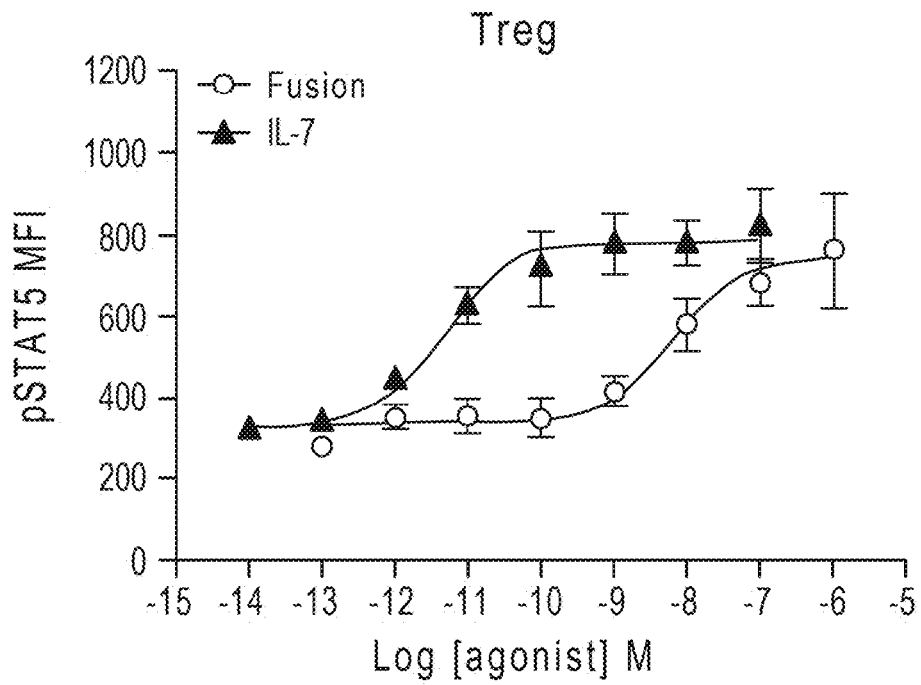

FIG. 11G

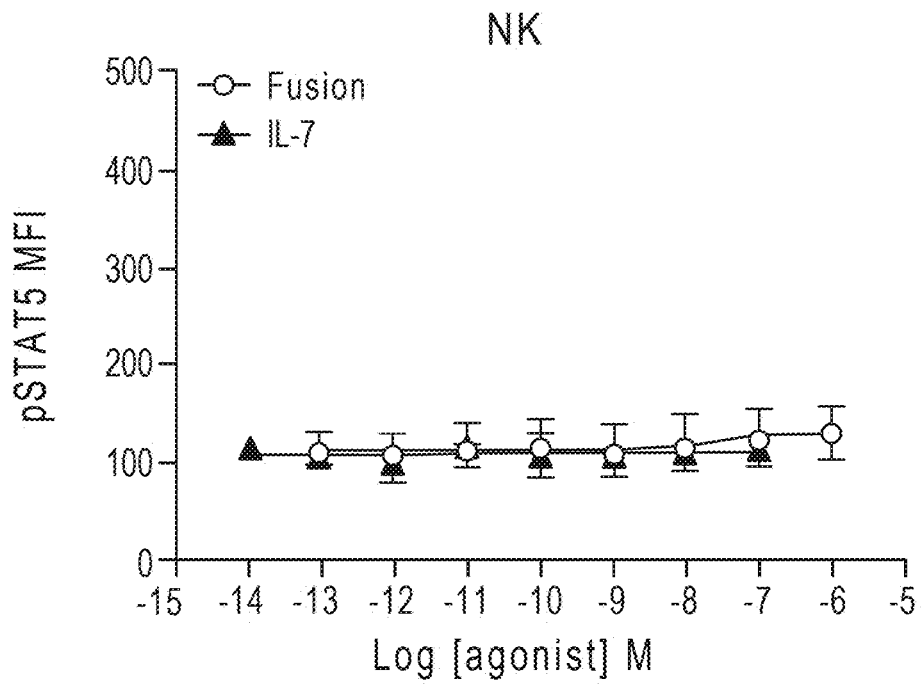

FIG. 11H

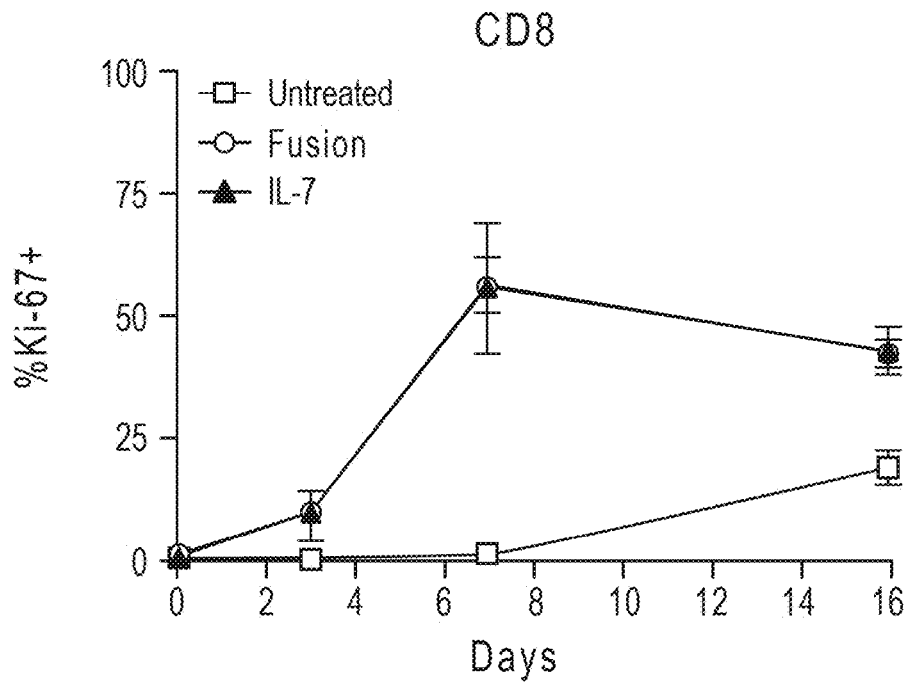

FIG. 12A

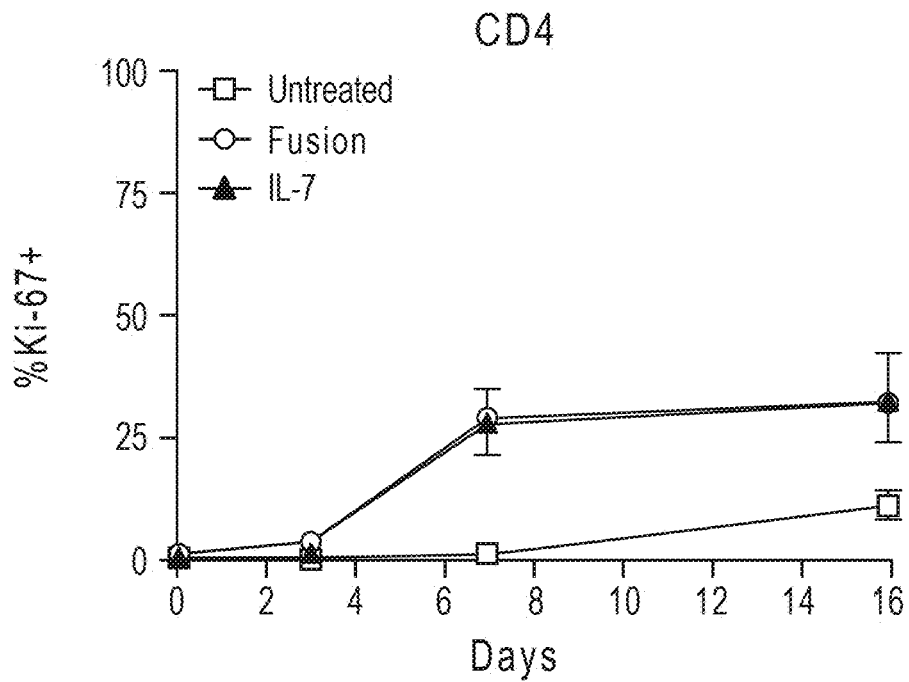

FIG. 12B

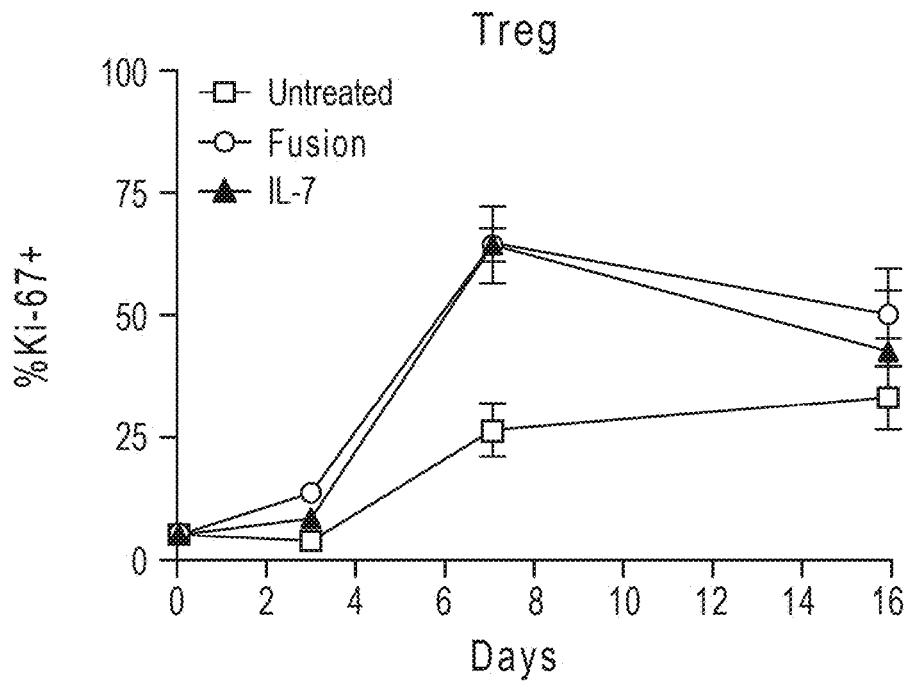

FIG. 12C

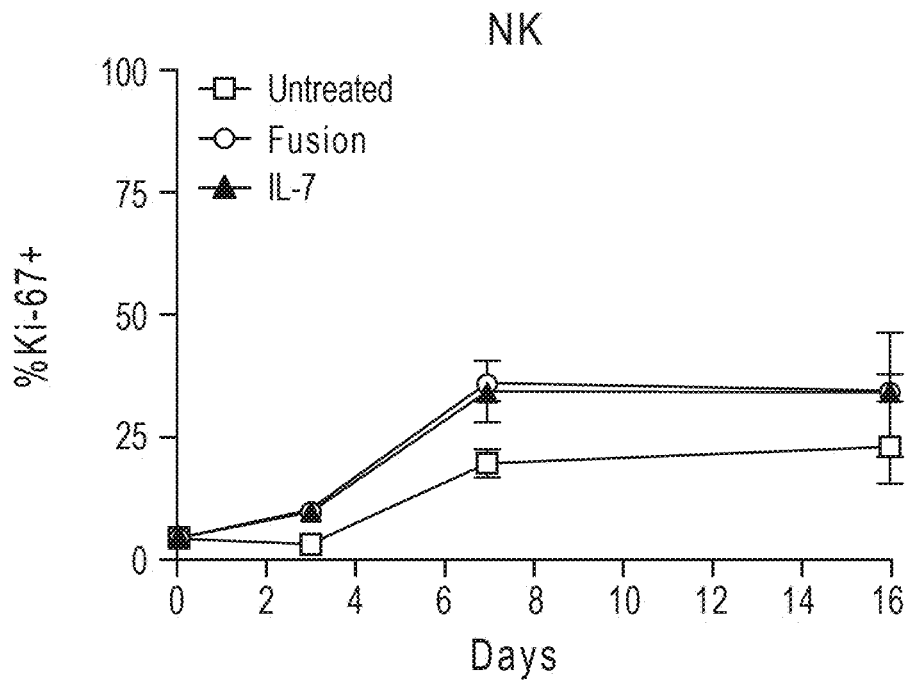

FIG. 12D

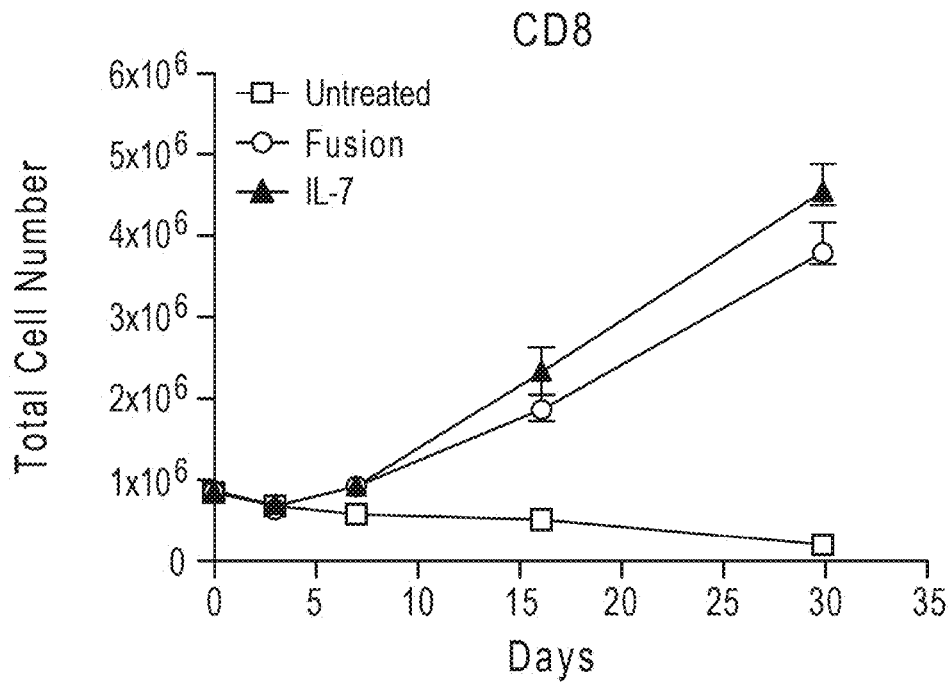

FIG. 13A

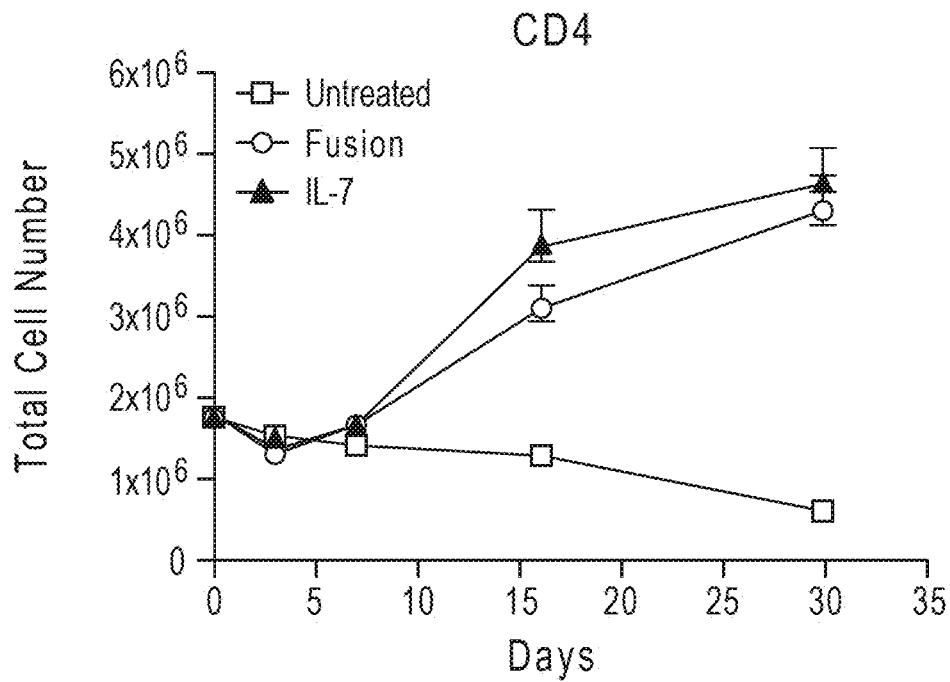

FIG. 13B

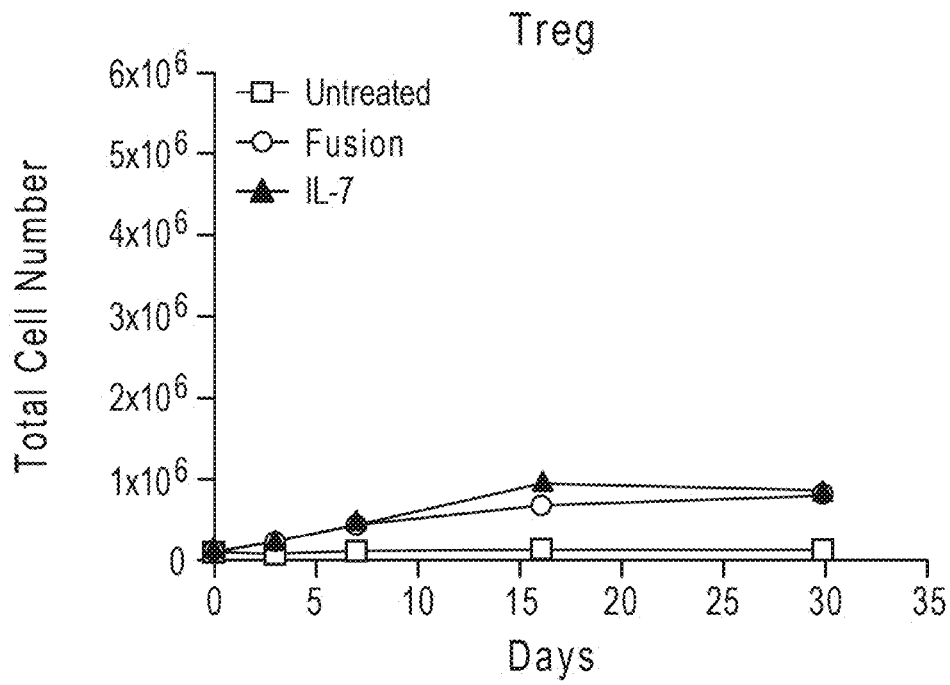

FIG. 13C

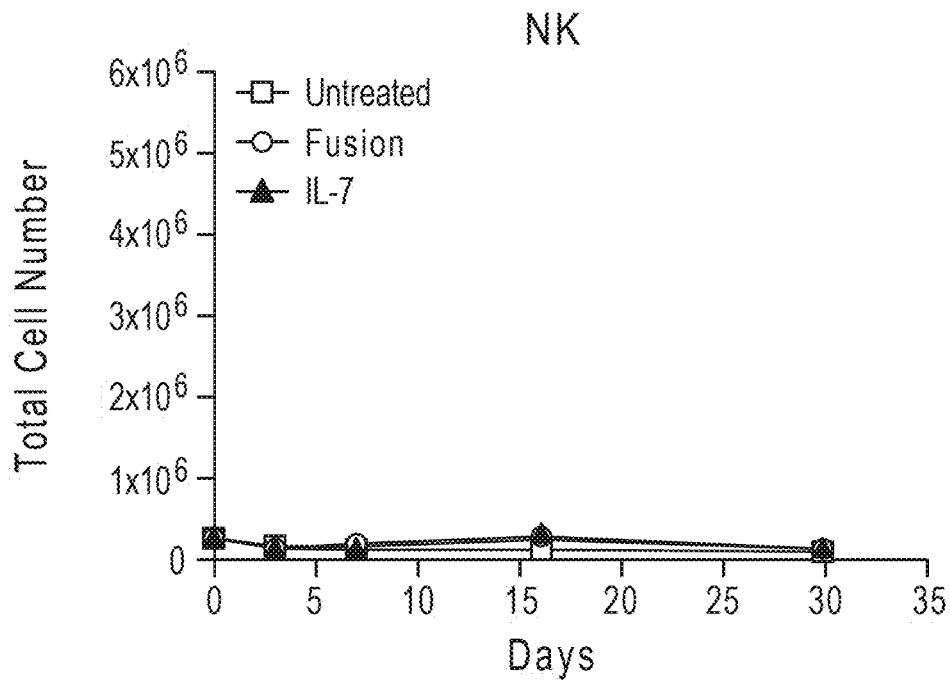

FIG. 13D

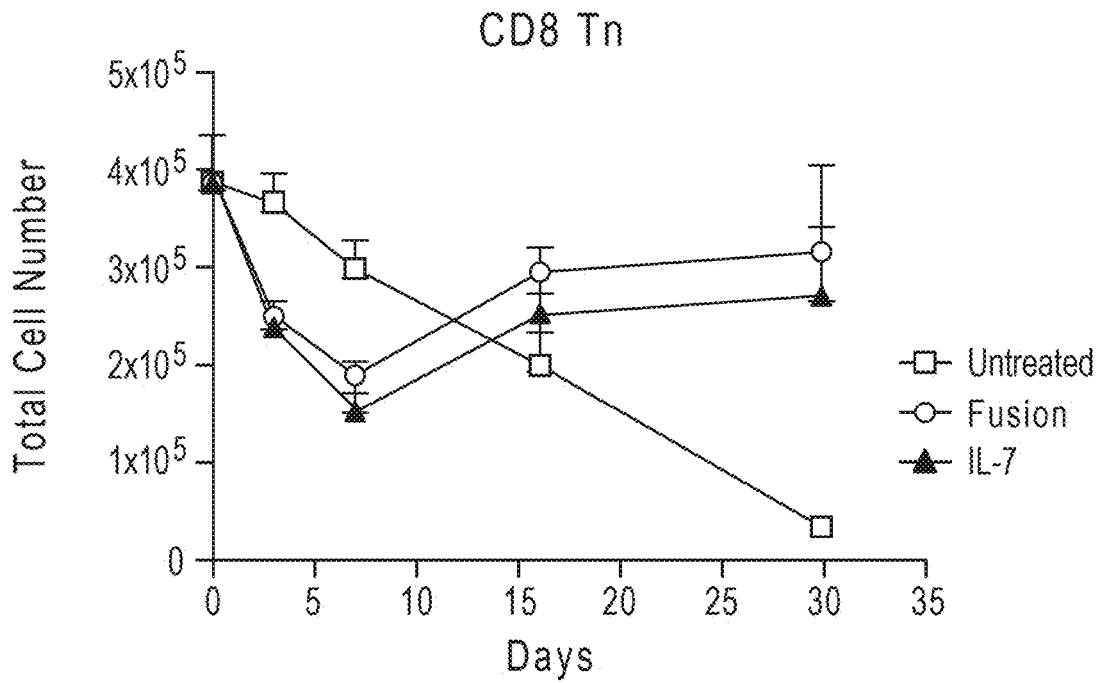

FIG. 14A

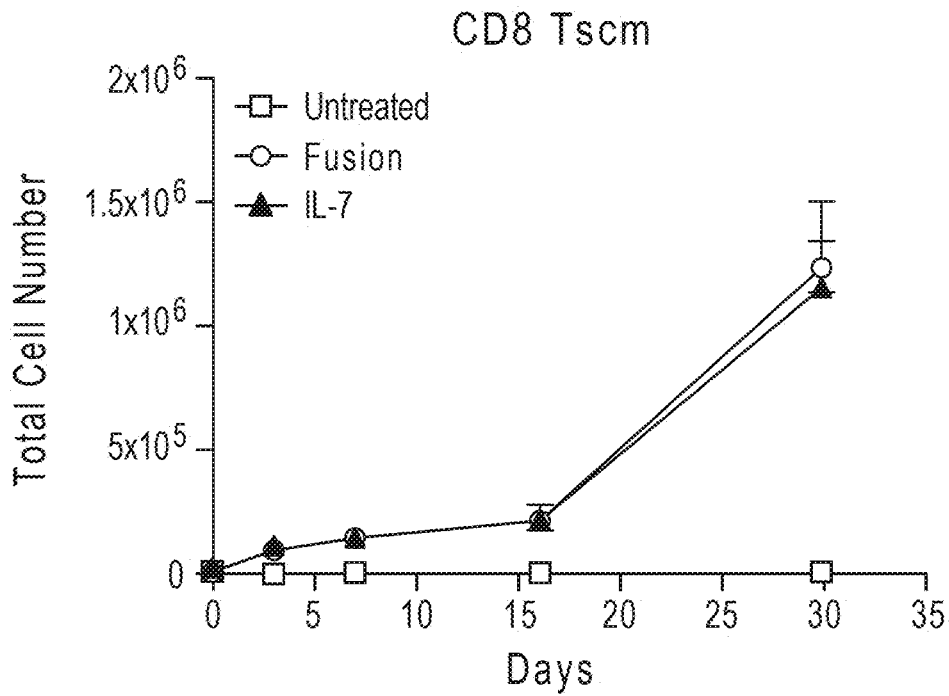

FIG. 14B

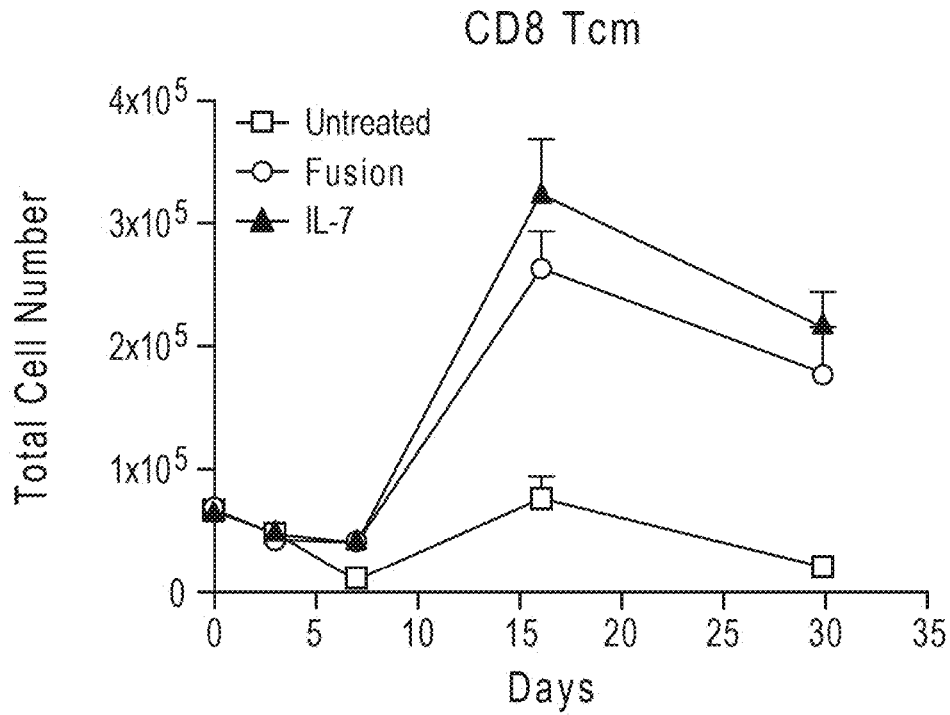

FIG. 14C

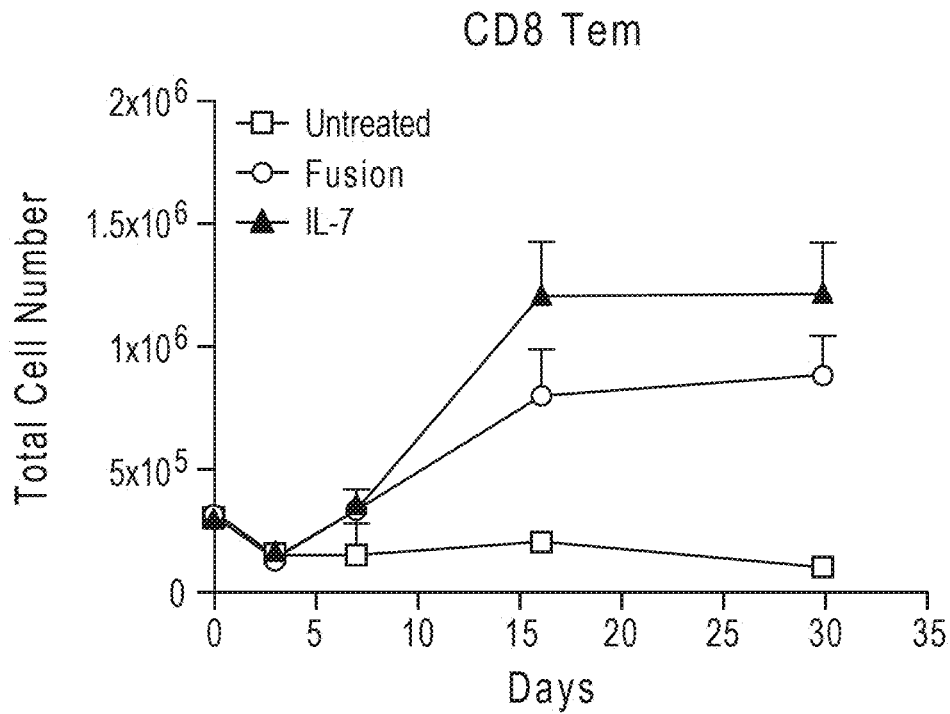

FIG. 14D

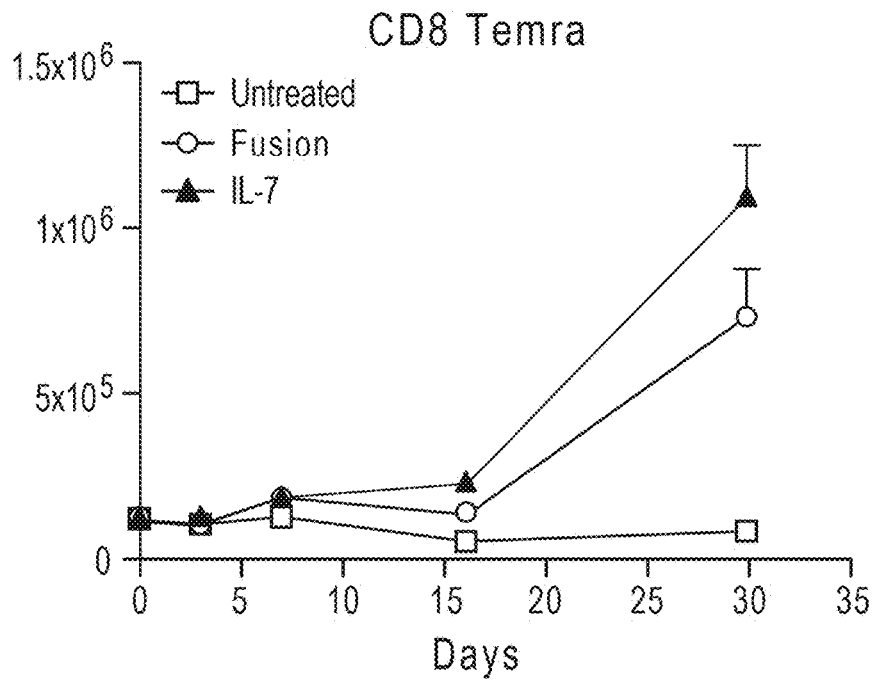

FIG. 14E

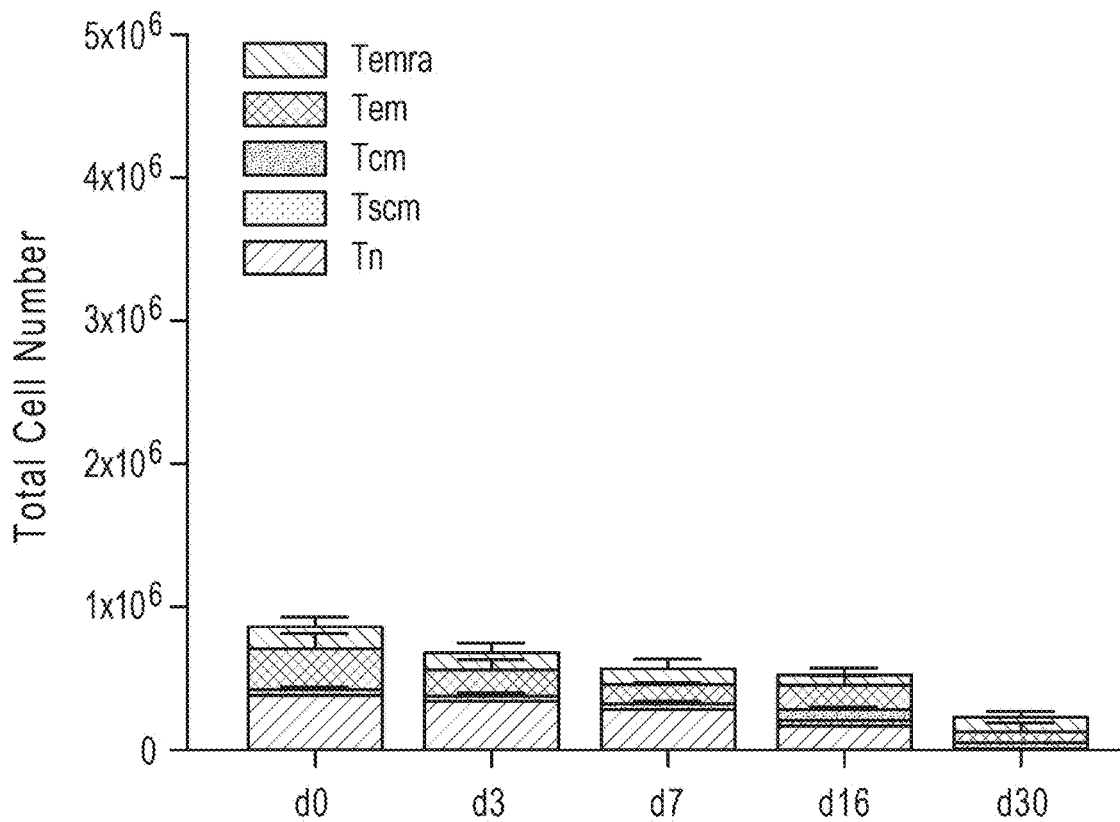

FIG. 15A

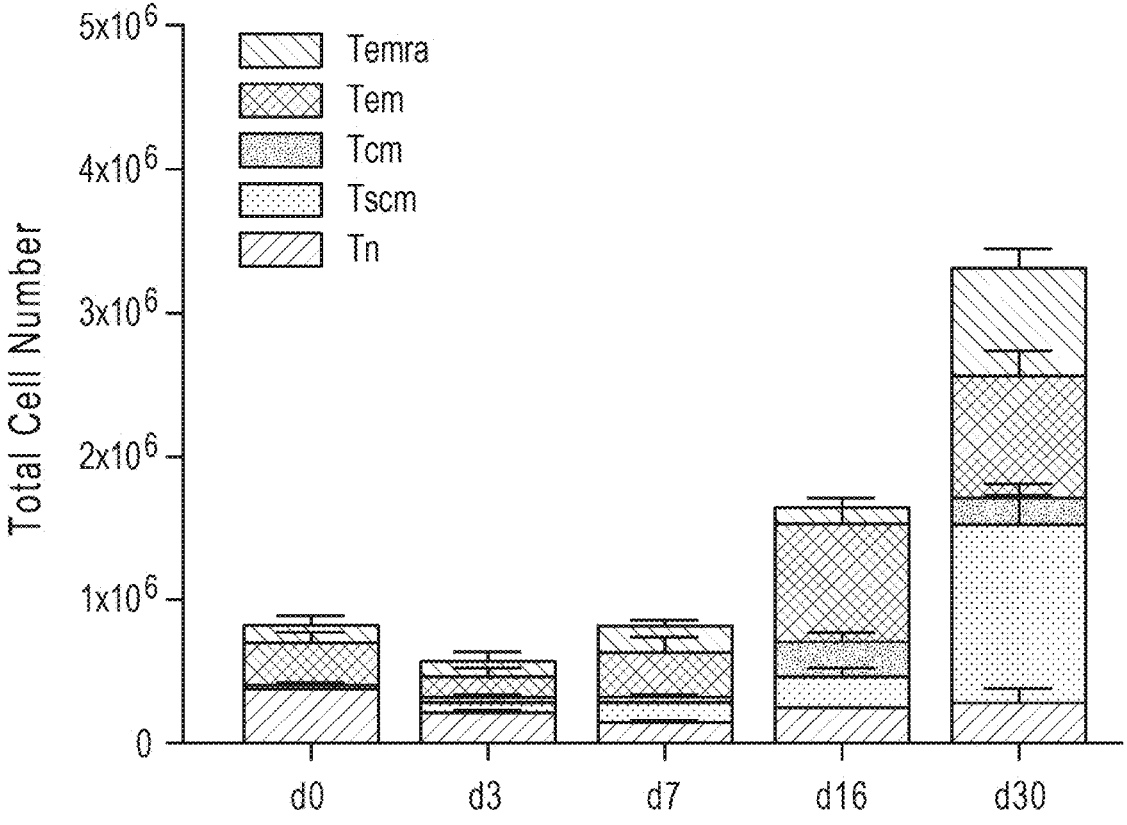

FIG. 15B

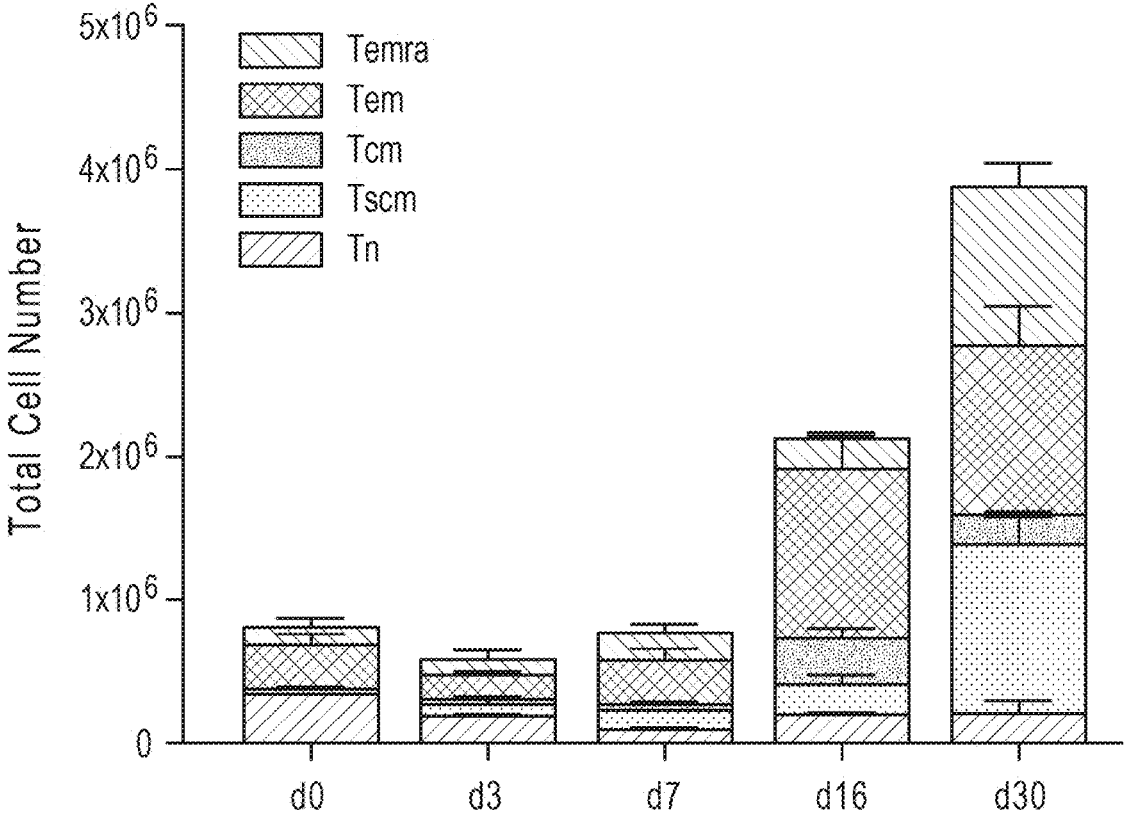

FIG. 15C

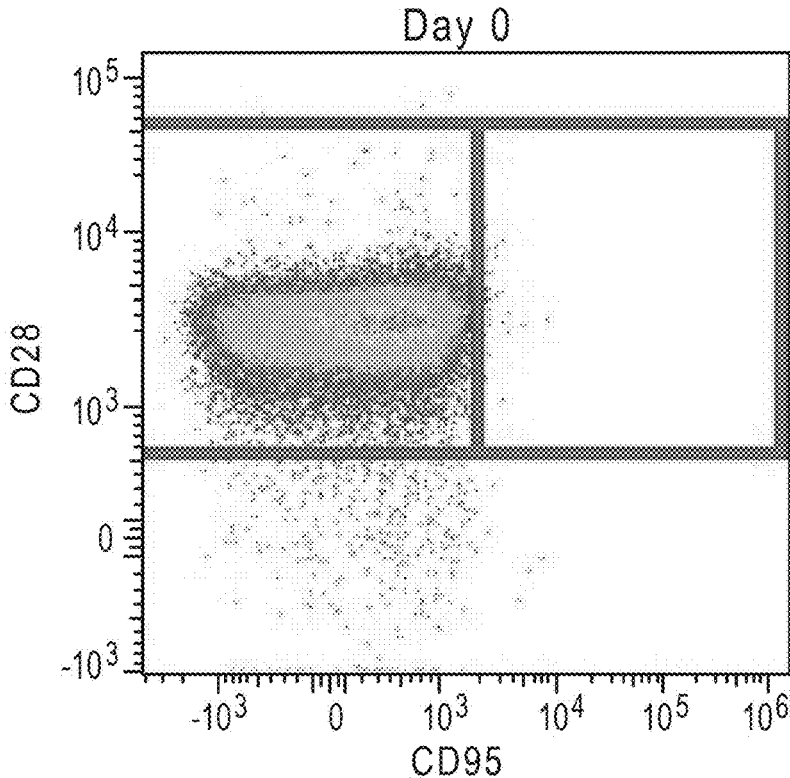

FIG. 16A

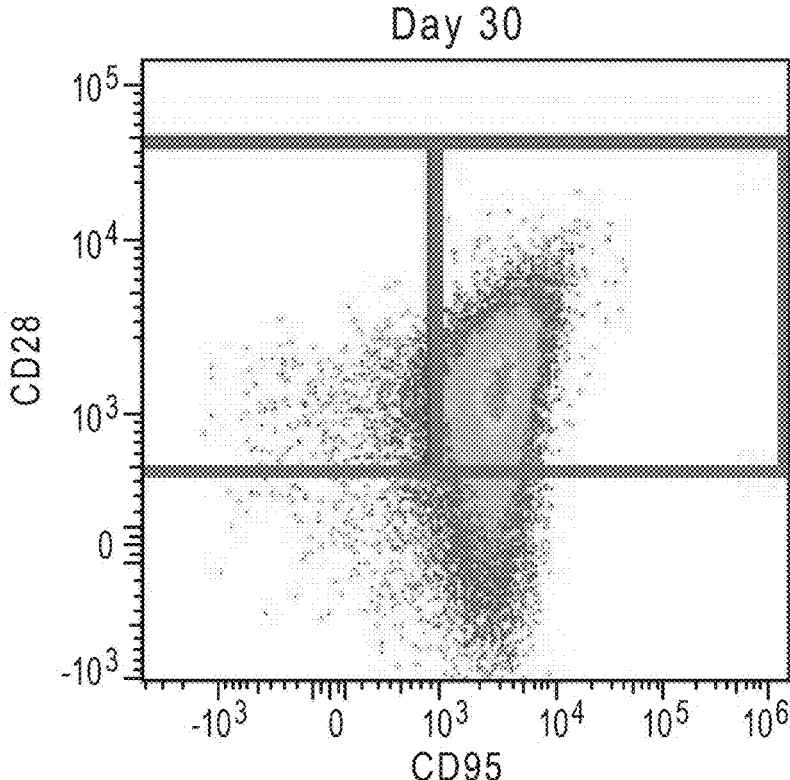

FIG. 16B

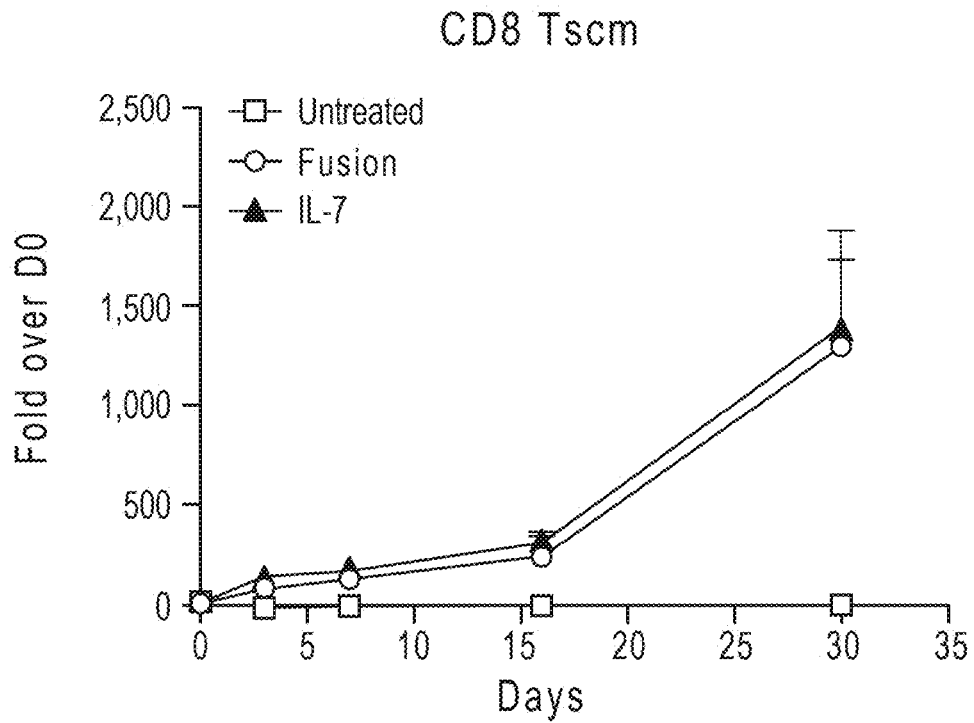

FIG. 17A

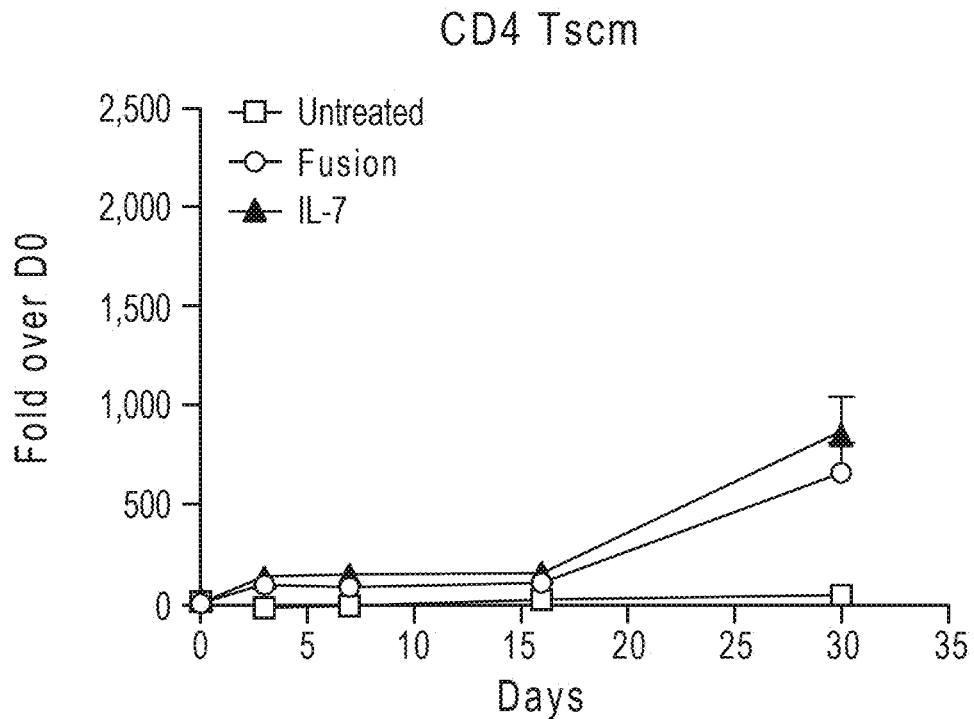

FIG. 17B

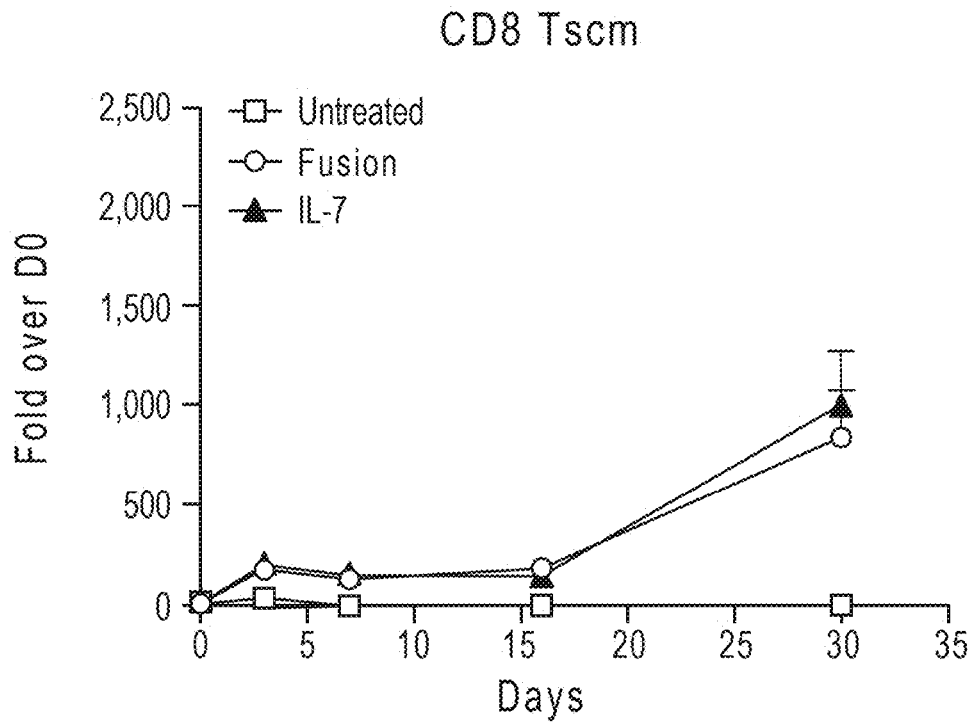

FIG. 17C

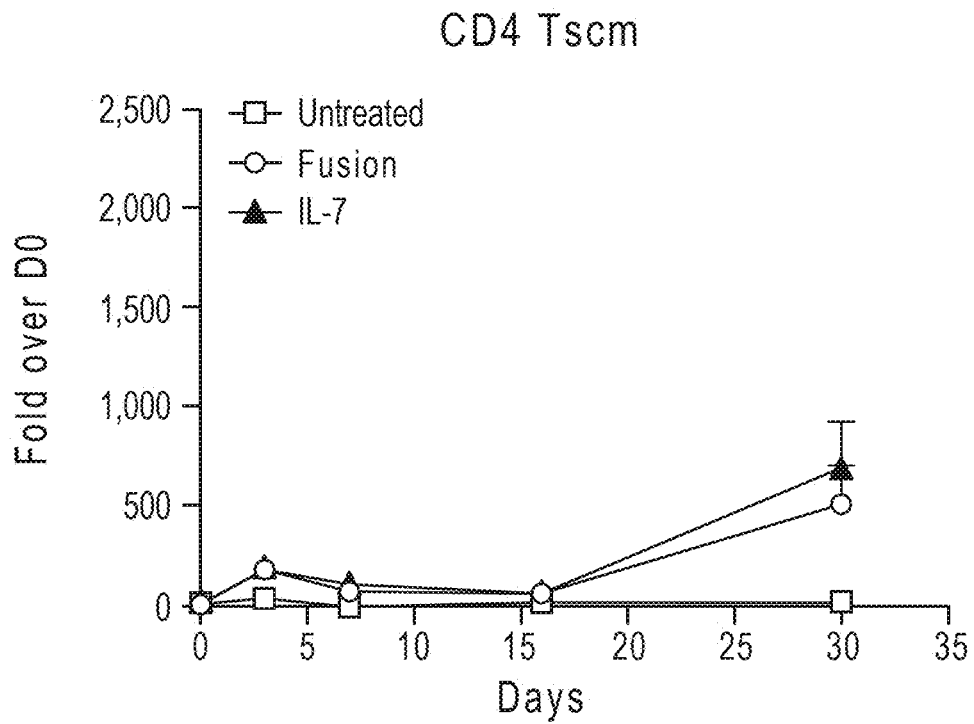

FIG. 17D

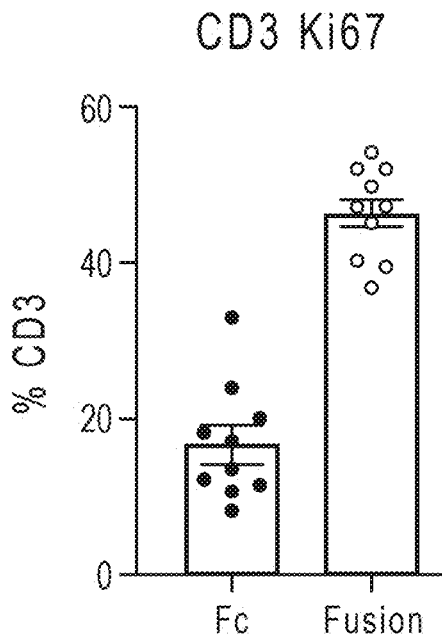

FIG. 18A

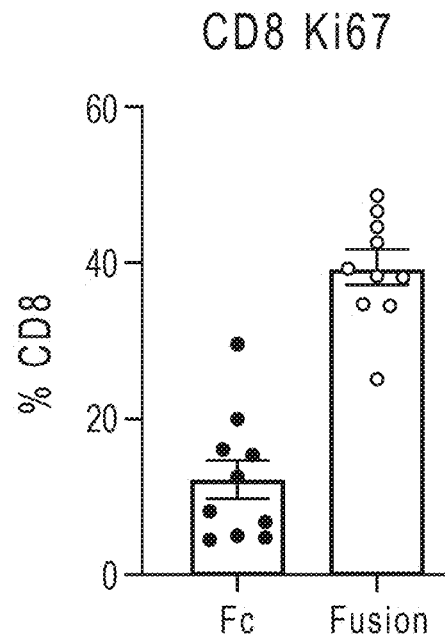

FIG. 18B

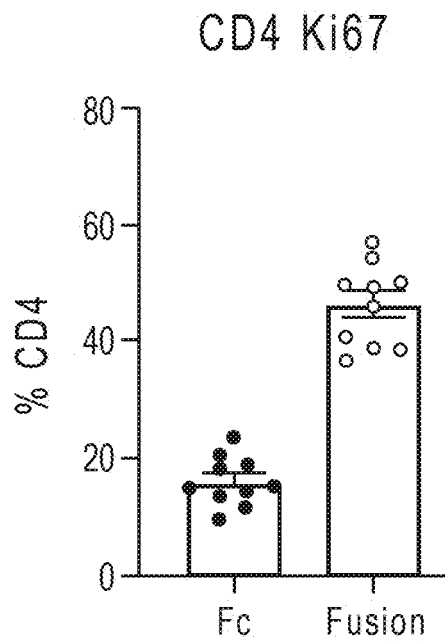

FIG. 18C

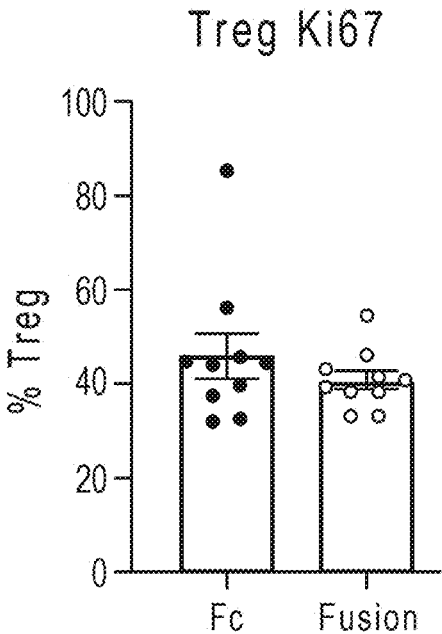

FIG. 18D

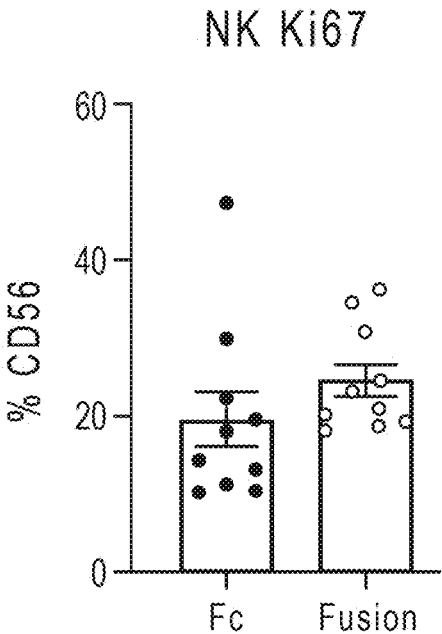

FIG. 18E

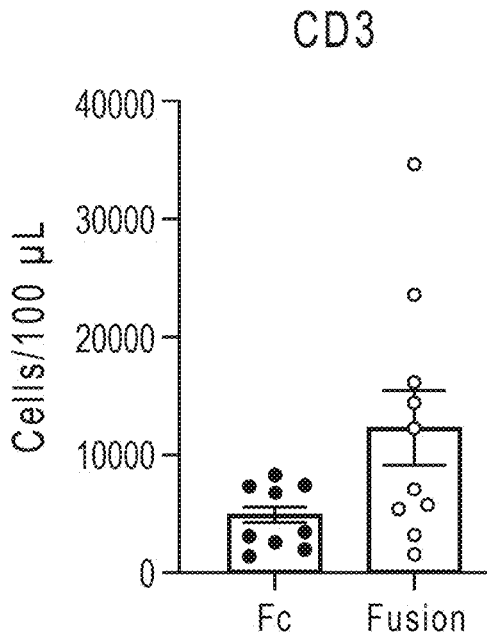

FIG. 19A

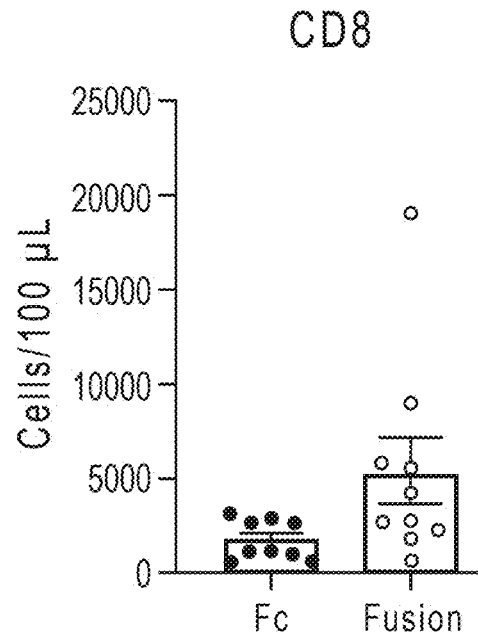

FIG. 19B

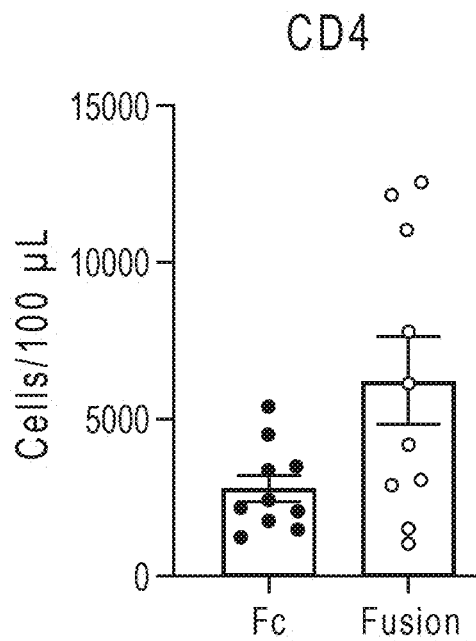

FIG. 19C

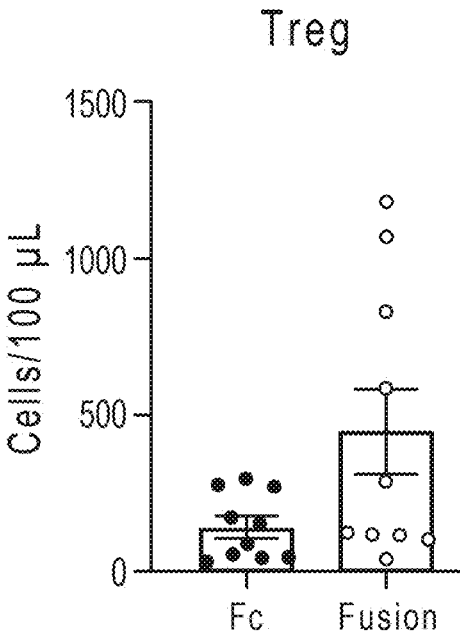

FIG. 19D

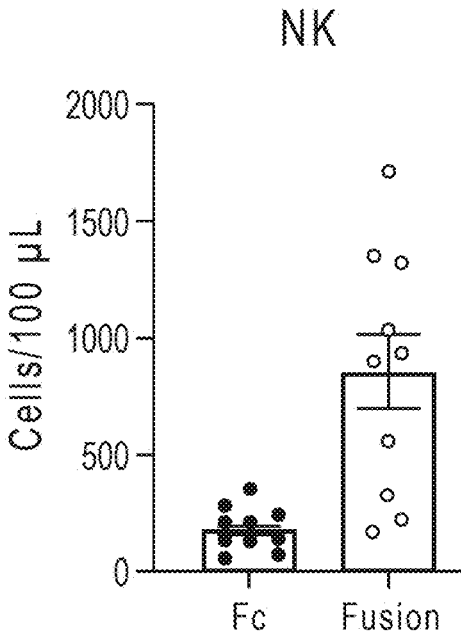

FIG. 19E

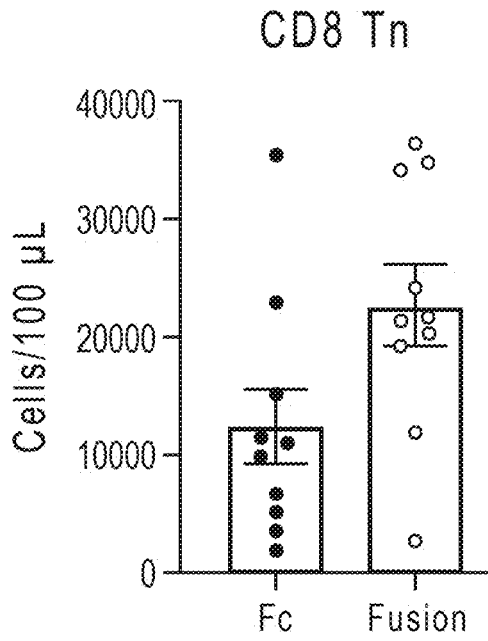

FIG. 20A

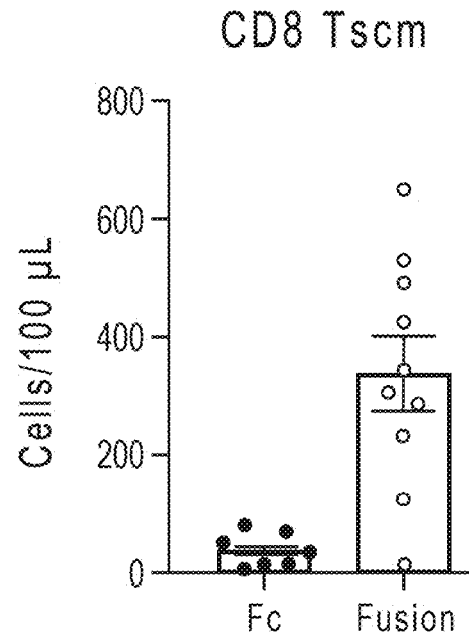

FIG. 20B

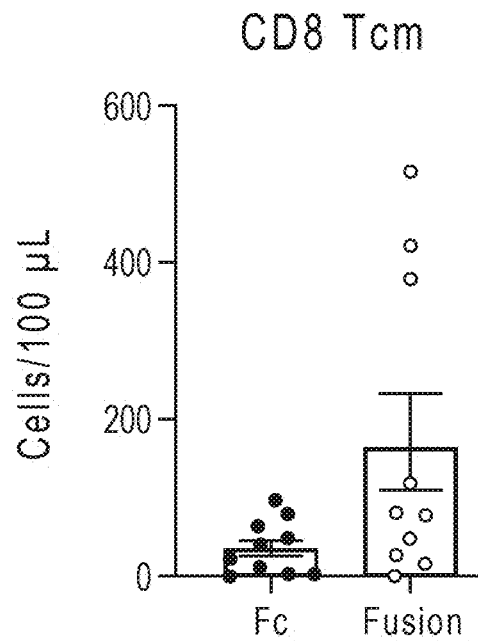

FIG. 20C

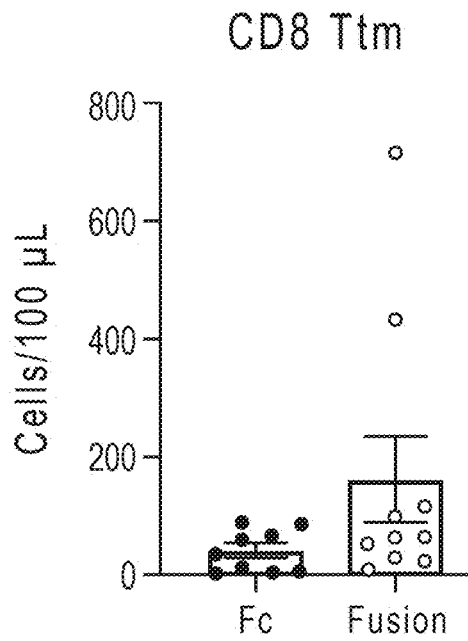

FIG. 20D

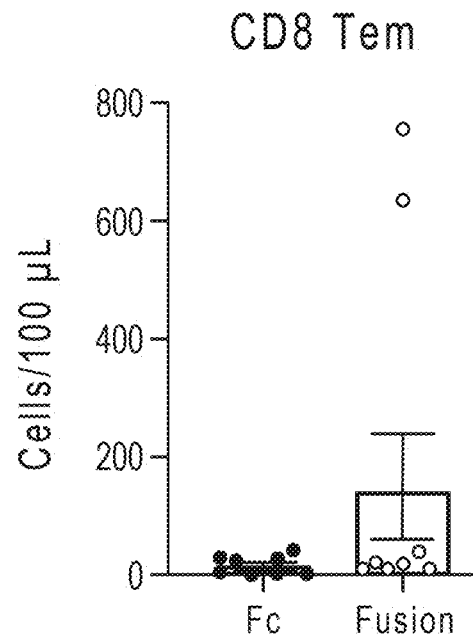

FIG. 20E

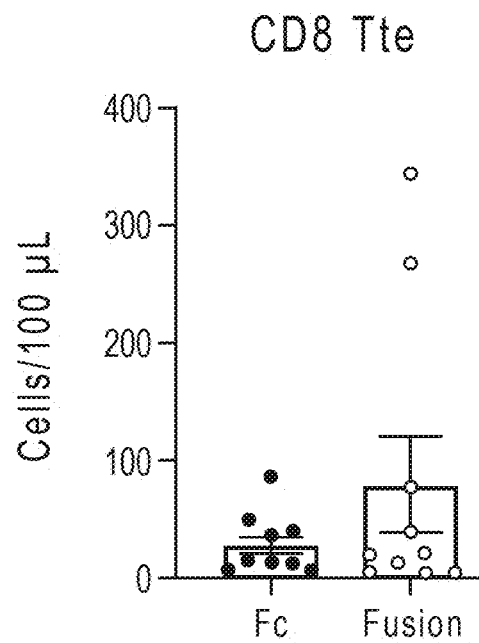

FIG. 20F

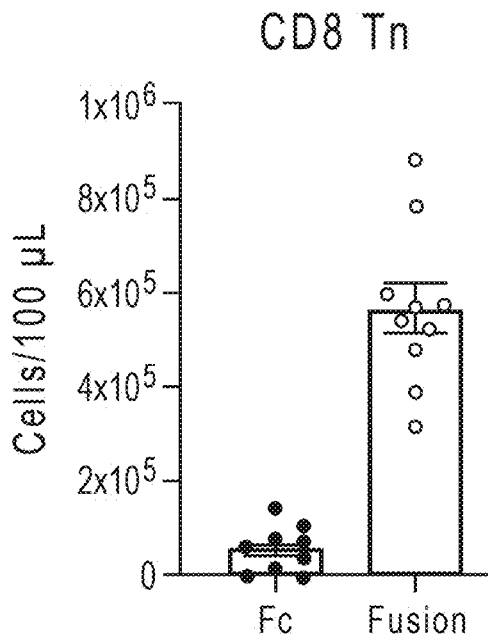

FIG. 21A

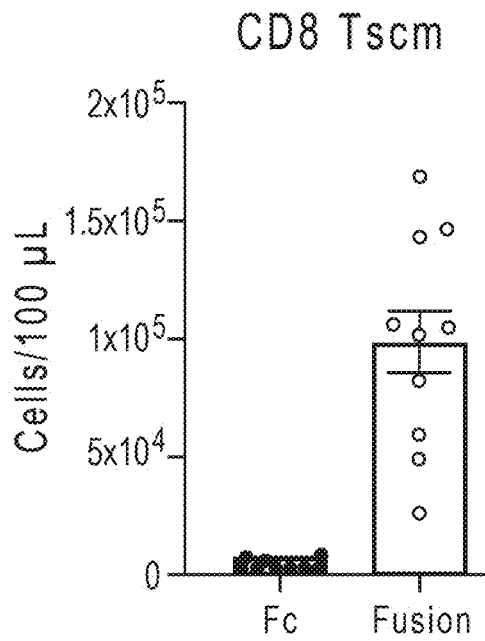

FIG. 21B

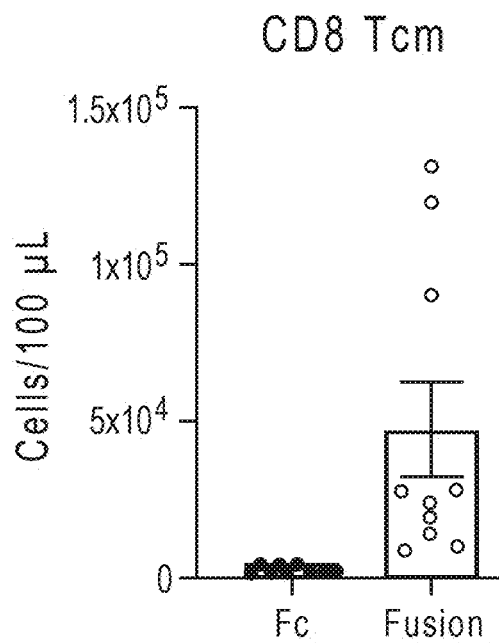

FIG. 21C

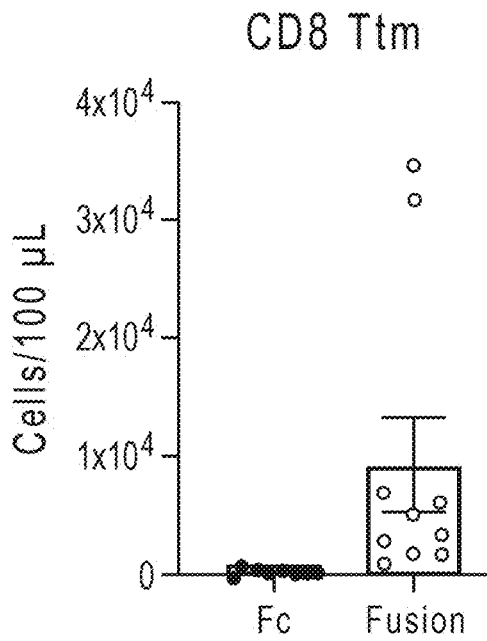

FIG. 21D

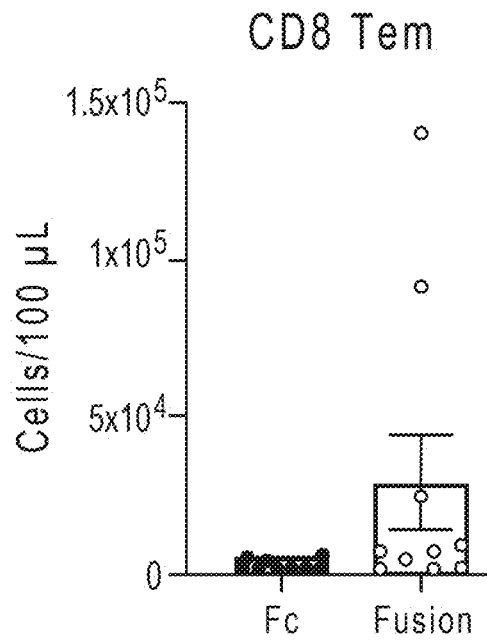

FIG. 21E

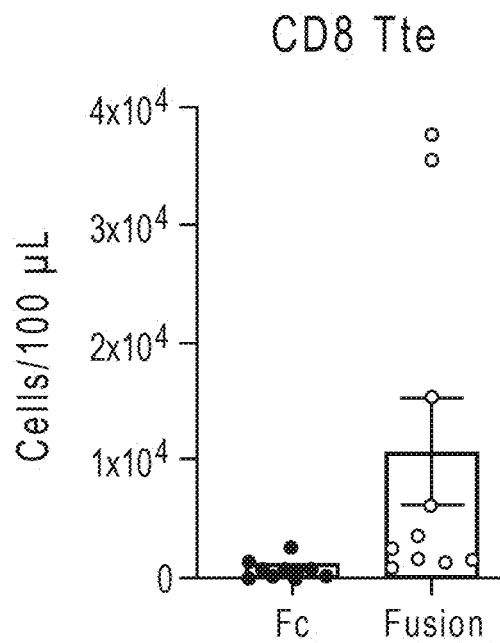

FIG. 21F

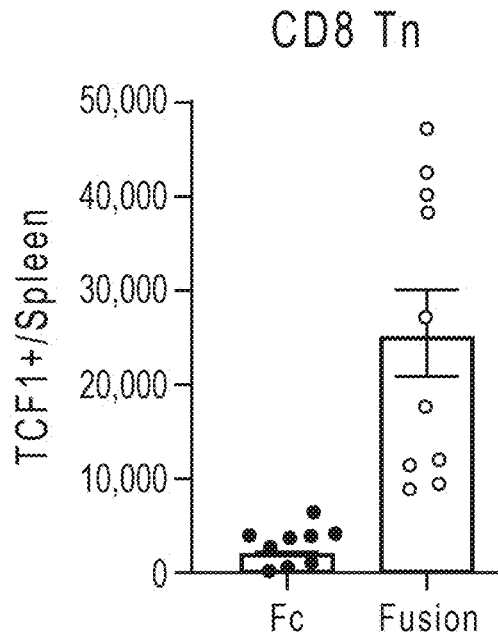

FIG. 22A

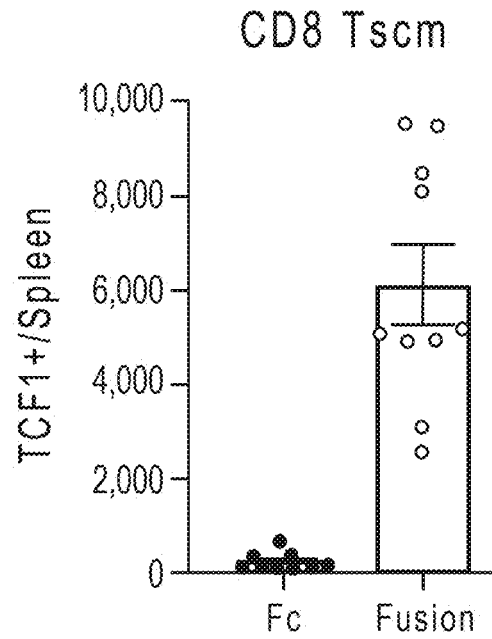

FIG. 22B

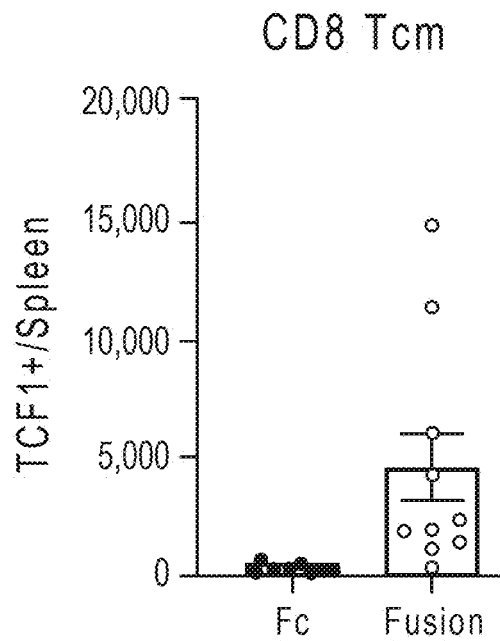

FIG. 22C

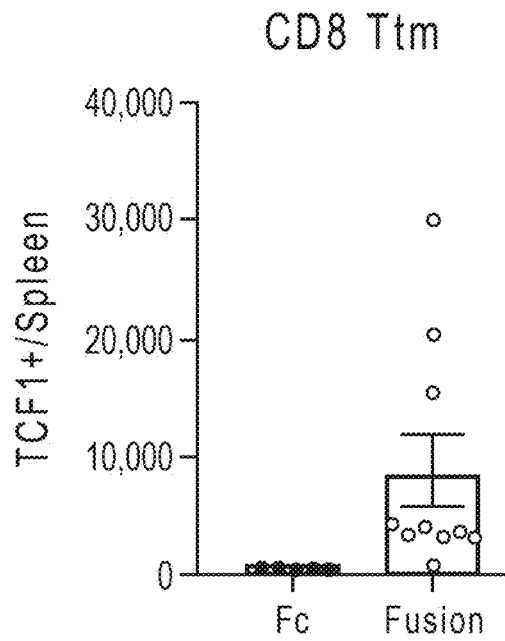

FIG. 22D

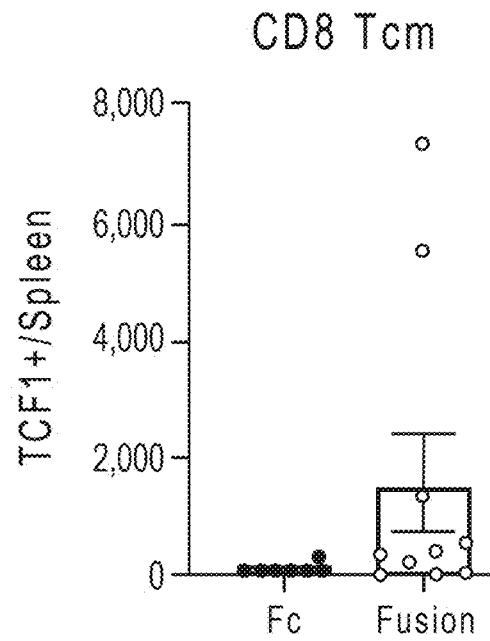

FIG. 22E

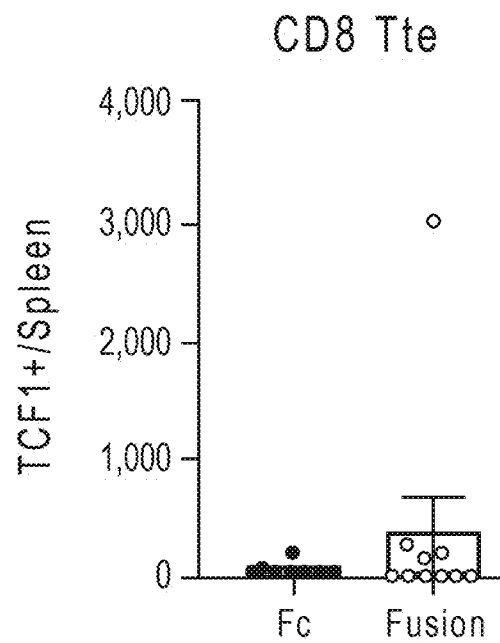

FIG. 22F

IL-7R α γ LIGAND IMMUNOGLOBULIN FUSION PROTEINS

This application claims the benefit under 35 U.S.C. § 119(e) of U.S. Provisional Application No. 63/328,700 filed on Apr. 7, 2022, which is incorporated by reference in its entirety.

FIELD

The present disclosure relates to IL-7R α γ ligands and IL-7R α γ IgG-Fc fusion proteins. The IL-7R α γ ligands and IL-7R α γ IgG-Fc fusion proteins are IL-7R agonists.

SEQUENCE LISTING

The present application contains a Sequence Listing which is included with this application and a copy of the Sequence Listing will be submitted electronically in XML format and is incorporated by reference in its entirety. The XML copy, created on Nov. 16, 2022, is named 62AJ-001410US-362859_SL.xml and is 207,077 bytes in size.

BACKGROUND

Interleukin-7 (IL-7) is required for the development and maintenance of T-cell homeostasis and plays an important role in the establishment of the B-cell repertoire. Unlike most interleukins, IL-7 is primarily produced by non-hematopoietic stromal cells rather than leukocytes. Under normal conditions, free IL-7 levels are limiting, but accumulate during lymphopenia, leading to increased T cell proliferation and replenishment of T-cell populations. Under certain physiological conditions, recombinant human IL-7 administered to humans, non-human primates, and mice produces widespread T cell proliferation, increased T cell numbers, modulation of peripheral T cell subsets, and increased T cell receptor repertoire diversity. These effects may be therapeutically useful in a variety of clinical settings.

IL-7 is a member of the common γ chain (γ c, CD132) family of cytokines that includes interleukin-2 (IL-2), IL-4, IL-7, IL-9, IL-15, and IL-21. IL-7 signals via an active complex formed with its unique α -receptor, IL-7R α (CD127), and the common γ c receptor (R γ c). Receptor activation leads to signaling through an array of pathways, including JAK-STAT, P13K-AKT, and Src kinases.

The IL-7R α receptor subunit exists in two states: a full-length membrane-bound form that, with R γ c, mediates IL-7R signal transduction; and soluble (alternatively-spliced, secreted, or shed) forms of the extracellular domain that may provide regulation of extracellular IL-7 levels and modulation of IL-7R signaling.

The cell surface signaling-competent form of IL-7R α is expressed on most resting T-cells and is down regulated upon T-cell activation, while naive memory T-cells continue to express IL-7R α ; and regulatory cells typically express very low levels of IL-7R α . IL-7R signaling is necessary for long-term maintenance of T cell populations, in part, by modulating apoptosis. Both CD4+ and CD8+ memory T-cells are dependent on IL-7 for long-term survival.

Emerging evidence suggests IL-7R agonists may be useful in immuno-oncology therapy. For example, IL-7 is effective in increasing cytotoxic CD8+ T lymphocytes (CD8+ T-cell), and long-term tumor antigen-specific CD8+ T-cell responses are enhanced by IL-7 treatment.

IL-7 exhibits inhibitory effects in tumors such as glioma, melanoma, lymphoma, leukemia, prostate cancer, and gli-

blastoma; and administration of IL-7 in murine tumor models has shown decreased cancer cell growth. IL-7 has been shown to enhance the antitumor effect of interferon- γ (IFN γ) in rat glioma tumors, and can induce the production of IL-1 α , IL-1 β , and TNF- α by monocytes, which can inhibit tumor growth.

IL-7 has been shown to have potential in the treatment of lymphopenias, septic shock, and infectious disease as well immune deficiencies of aging (immuno-senescence), and enhancement of response to vaccination. IL-7 prevents or reverses T-cell exhaustion and induces rejuvenation and increased activity of transferred CAR-T cells. IL-7 is currently being studied to prevent or reverse lymphopenia associated with COVID-19. IL-7/IL-7R signaling has also been implicated in autoimmune diseases, chronic inflammatory diseases, and cancer, and therefore therapeutic targeting of the IL-7/IL-7R pathway is expected to have clinical benefit.

Importantly, the administration of recombinant IL-7 has been found to be well tolerated in clinical trials.

SUMMARY

According to the present invention, IL-7R α γ ligands comprise an IL-7R α ligand comprising an amino acid sequence of SEQ ID NO: 1 or an amino acid sequence having greater than 70% sequence similarity to any one of SEQ ID NO: 1; and an R γ c ligand comprising an amino acid sequence of SEQ ID NO: 11 or an amino acid sequence having greater than 70% sequence similarity to SEQ ID NO: 11.

According to the present invention, IL-7R α γ IgG-Fc fusion proteins comprise an IgG-Fc fragment bound to an IL-7R α γ ligand according to the present invention.

According to the present invention, pharmaceutical compositions comprise an IL-7R α γ ligand according to the present invention.

According to the present invention, pharmaceutical compositions comprise an IL-7R α γ IgG-Fc fusion protein according to the present invention.

According to the present invention, methods of treating a cancer, an inflammatory disease, an autoimmune disease, or a viral disease in a patient comprise administering to a patient in need of such treatment a therapeutically effective amount of an IL-7R α γ ligand according to the present invention, or an IL-7R α γ IgG-Fc fusion protein according to the present invention.

According to the present invention, methods of treating a cancer, an inflammatory disease, an autoimmune disease, or a viral disease in a patient comprise administering to a patient in need of such treatment a therapeutically effective amount of an IL-7R α γ ligand according to the present invention, or an IL-7R α γ IgG-Fc fusion protein according to the present invention.

According to the present invention, nucleic acids encode for an IL-7R α γ ligand according to the present invention.

According to the present invention, nucleic acids encode for an IL-7R α γ IgG-Fc fusion protein according to the present invention.

BRIEF DESCRIPTION OF THE DRAWINGS

The drawings described herein are for illustration purposes only. The drawings are not intended to limit the scope of the present disclosure.

FIG. 1 shows competitive binding of an IL-7R α γ ligand having SEQ ID NO: 30 to the hu-IL-7R α subunit.

FIG. 2 shows competitive binding of an IL-7R α yc ligand having SEQ ID NO: 30 to the hu-Ryc subunit.

FIG. 3 shows STAT5 phosphorylation in TF-1-7R α cells following exposure to an IL-7R α yc ligand SEQ ID NO: 30.

FIG. 4 shows a schematic structure of an IL-7R α yc IgG-Fc fusion protein provided by the present disclosure.

FIG. 5 shows the mean plasma concentration of an IL-7R α yc IgG2-Fc fusion protein having SEQ ID NO: 45 following intravenous (IV), subcutaneous (SC), and intramuscular (IM) administration at a dose of 1 mg/kg to non-human primates.

FIG. 6 shows the percent change in blood lymphocyte counts following intravenous (IV), subcutaneous (SC), and intramuscular (IM) administration of a 1 mg/kg dose of an IL-7R α yc IgG2-Fc fusion protein having SEQ ID NO: 45 to non-human primates.

FIGS. 7A and 7B show the plasma IL-7R α yc IgG2-Fc fusion protein (SEQ ID NO: 45) C_{max} and AUC_{inf} respectively, following subcutaneous administration at doses of from 0.1 mg/kg to 3.0 mg/kg to non-human primates.

FIGS. 8A-8D show the percent change in blood lymphocyte counts following subcutaneous administration of from 0.1 mg/kg to 3.0 mg/kg of an IL-7R α yc IgG2-Fc fusion protein (SEQ ID NO: 45) to non-human primates.

FIGS. 9A-9D show the percent change in CD8+ T cell counts in peripheral blood following subcutaneous administration of from 0.1 mg/kg to 3.0 mg/kg of an IL-7R α yc IgG2-Fc fusion protein (SEQ ID NO: 45) to non-human primates.

FIGS. 10A-10D show the percent change in CD4+ T cell counts in peripheral blood following subcutaneous administration of from 0.1 mg/kg to 3.0 mg/kg of an IL-7R α yc IgG2-Fc fusion protein (SEQ ID NO: 45) to non-human primates.

FIGS. 11A-11D show STAT5 phosphorylation in CD8+ T, CD4+ T, Treg, and NK cells in human PBMCs, respectively, following exposure to the IL-7R α yc IgG2-Fc fusion protein having SEQ ID NO: 45 or to IL-7.

FIGS. 11E-11H show STAT5 phosphorylation in CD8+ T, CD4+ T, Treg, and NK cells in resting Cynomolgus monkey peripheral blood mononuclear cells (PBMCs), respectively, following exposure to the IL-7R α yc IgG2-Fc fusion protein having SEQ ID NO: 45 or to IL-7.

FIGS. 12A-12D show Ki-67 frequency in untreated CD8+ T, CD4+ T, Treg, and NK cells, respectively, and in CD8+ T, CD4+ T, Treg, and NK cells from resting PBMCs following exposure to the IL-7R α yc IgG2-Fc fusion protein having SEQ ID NO: 45 or to IL-7.

FIGS. 13A-13D show the total cell number in untreated CD8+ T, CD4+ T, Treg, and NK cells, respectively, and in CD8+ T, CD4+ T, Treg, and NK cells in PBMCs following exposure to the IL-7R α yc IgG2-Fc fusion protein having SEQ ID NO: 45 or to IL-7.

FIGS. 14A-14E show total cell number of CD8+ Tn (naïve T), CD8+ Tscm (stem memory T), CD8+ Tcm (central memory T), CD8+ Tem (effector memory T), and CD8+ Temra (terminally differentiated effector memory T) cells, respectively, without treatment or following exposure to the IL-7R α yc IgG2-Fc fusion protein having SEQ ID NO: 45 or to IL-7.

FIGS. 15A-15C show the sum of cell numbers of CD8+ Tn, CD8+ Tscm, CD8+ Tcm, CD8+ Tem, and CD8+ Temra cells, without treatment (FIG. 15A) or following exposure to the IL-7R α yc IgG2-Fc fusion protein having SEQ ID NO: 45 (FIG. 15B) or following exposure to IL-7 (FIG. 15C).

FIGS. 16A and 16B show the relative populations of CD28+CD95-CD8+ Tn cells and CD28+CD95+CD8+

Tscm cells in resting PBMCs before treatment (FIG. 16A), and at 30 days following exposure (FIG. 16B) to the IL-7R α yc IgG2-Fc fusion protein having SEQ ID NO: 45.

FIG. 17A-17D show the expansion of Tscm cells (stem memory T cells) in resting PBMCs (FIGS. 17A-17B) and in CD3-activated PBMCs (FIGS. 17C-17D).

FIGS. 18A-18E show T-cell and NK cell subpopulations in Ki-67+ cells from humanized mice treated with either a control Fc fragment or the IL-7R α yc IgG2-Fc fusion protein having SEQ ID NO: 45.

FIGS. 19A-19E show T-cell and NK cell counts in peripheral blood from humanized mice treated with either a control Fc fragment or the IL-7R α yc IgG2-Fc fusion protein having SEQ ID NO: 45.

FIGS. 20A-20F show memory T-cell subpopulations in blood from humanized mice treated with either control a Fc fragment or the IL-7R α yc IgG2-Fc fusion protein having SEQ ID NO: 45.

FIGS. 21A-21F show memory T-cell populations in the spleen from humanized mice treated with either a control Fc fragment or the IL-7R α yc IgG2-Fc fusion protein having SEQ ID NO: 45.

FIGS. 22A-22F show TCF1+ expression in memory cells in the spleen from humanized mice treated with either a control Fc fragment or the IL-7R α yc IgG2-Fc fusion protein having SEQ ID NO: 45.

DETAILED DESCRIPTION

“Agonist” refers to a biologically active ligand that binds to its complementary biologically active receptor or subunit(s) and activates the receptor to cause a biological response mediated by the receptor, or to enhance a pre-existing biological activity mediated by the receptor.

Amino acid residues are abbreviated as follows: alanine is Ala or A; arginine is Arg or R; asparagine is Asn or N; aspartic acid is Asp or D; cysteine is Cys or C; glutamic acid is Glu or E; glutamine is Gln or Q; glycine is Gly or G; histidine is His or H; isoleucine is Ile or I; leucine is Leu or L; lysine is Lys or K; methionine is Met or M; phenylalanine is Phe or F; proline is Pro or P; serine is Ser or S; threonine is Thr or T; tryptophan is Trp or W; tyrosine is Tyr or Y; and valine is Val or V.

“Conservative amino acid substitution” means that amino acids within each of the following groups can be substituted with another amino acid within the group: amino acids having a small hydrophobic side chain comprising alanine (A), glycine (G), proline (P), serine (S), and threonine (T); amino acids having a hydroxyl-containing side chain comprising serine (S), threonine (T), and tyrosine (Y); amino acids having an acidic side chain comprising aspartate (D) and glutamate (E); amino acids comprising a polar-neutral side chain comprising histidine (H), asparagine (N), glutamine (Q), serine (S), threonine (T), and tyrosine (Y); amino acids having a basic side chain comprising arginine (R), lysine (K), and histidine (H); amino acids having a large hydrophobic side chain comprising isoleucine (I), leucine (L), methionine (M), valine (V), phenylalanine (F), tyrosine (Y), and tryptophan (W)); and amino acids having an aromatic side chain comprising phenylalanine (F), histidine (H), tryptophan (W), and tyrosine (Y).

An “IL-7R α ligand” refers to a peptide capable of binding to the IL-7R α subunit of a mammalian IL-7 receptor, such as the IL-7R α subunit (hu-IL-7R α subunit) of the human IL-7 receptor (hu-IL-7 receptor), with an IC_{50} of less than 100 μ M as determined using an enzyme linked immunosorbent assay (ELISA) binding assay.

An “R γ c ligand” refers to a peptide capable of binding to the R γ c subunit of a mammalian IL-7 receptor, such the IL-7R γ c subunit (hu-IL-7R γ c subunit) of the human IL-7 receptor, with an IC₅₀ of less than 100 μ M, as determined using ELISA binding assay.

An “IL-7R $\alpha\gamma$ c ligand” refers to a ligand consisting of or comprising one or more IL-7R α ligands and one or more R γ c ligands. The one or more IL-7R α ligands and one or more R γ c ligands can be bound together with an IL-7R $\alpha\gamma$ c ligand linker. An IL-7R $\alpha\gamma$ c ligand can comprise an IL-7R $\alpha\gamma$ c ligand comprising two or more IL-7R $\alpha\gamma$ c ligands, or an IL-7R $\alpha\gamma$ c ligand can comprise a single ligand that simultaneously binds to both the IL-7R α subunit and to the IL-7R γ c subunit. An IL-7R $\alpha\gamma$ c ligand is capable of binding to a mammalian IL-7R α subunit and to the IL-7R γ c subunit such as the hu-IL-7R α subunit and to the hu-IL-7R γ c subunit of IL-7R with an IC₅₀ of less than 100 μ M.

The “hu-IL-7R α subunit” refers to the human (*Homo sapiens*) interleukin-7 receptor subunit α precursor NCBI Reference Sequence NP_002176.2.

The “hu-R γ c subunit” refers to the human (*Homo sapiens*) interleukin-7 receptor subunit γ c precursor NCBI Reference Sequence NP_000197.1.

“Hu-IL-7R” refers to the human IL-7R receptor, which is a heterodimer, and consists of two subunits, interleukin-7 receptor- α (CD127) and common- γ chain receptor (CD132).

A recombinant “ligand fusion protein” refers to a protein made by recombinant DNA technology in which the translational reading frame of a ligand of a mammalian IL-7 receptor is fused to that of another protein, i.e., the IL-7R ligand fusion partner, to produce a single recombinant polypeptide. A ligand fusion protein can comprise an IL-7R α ligand and a R γ c ligand and/or an IL-7R $\alpha\gamma$ c ligand. A fusion partner can be the Fc domain of an IgG molecule where the IL-7R $\alpha\gamma$ c ligand is bonded to one or to both of the two N-termini of the IgG CH3 domain. A ligand fusion protein can include a peptidyl fusion linker binding the IL-7R $\alpha\gamma$ c ligand to the IgG molecule, such that the peptidyl linker amino acid sequence is not derived from either the IL-7R $\alpha\gamma$ c ligand or from the IgG molecule. Peptidyl fusion linkers can be incorporated into fusion proteins as spacers to promote suitable protein folding and stability of the component protein moieties, to improve protein expression, and/or to impart bioactivity of the two fusion partners. Peptidyl linkers can include, for example, a flexible peptide or a rigid peptide.

“Patient” refers to a mammal, for example, a human.

“Pharmaceutically acceptable” refers to approved or approvable by a regulatory agency of the Federal or a state government or listed in the U.S. Pharmacopoeia or other generally recognized pharmacopoeia for use in animals, and more particularly in humans.

“Pharmaceutically acceptable vehicle” refers to a pharmaceutically acceptable diluent, a pharmaceutically acceptable adjuvant, a pharmaceutically acceptable excipient, a pharmaceutically acceptable carrier, or a combination of any of the foregoing with which a compound provided by the present disclosure may be administered to a patient and which does not destroy the pharmacological activity thereof and which is non-toxic when administered in doses sufficient to provide a therapeutically effective amount of the compound.

“Pharmaceutical composition” refers to a composition comprising an IL-7R $\alpha\gamma$ c ligand provided by the present disclosure and/or an IL-7R $\alpha\gamma$ c IgG-Fc fusion protein and at least one pharmaceutically acceptable vehicle with which

the IL-7R $\alpha\gamma$ c ligand and/or an IL-7R $\alpha\gamma$ c IgG-Fc fusion protein is administered to a patient.

“Preventing” or “prevention” refers to a reduction in risk of acquiring a disease or disorder such as, for example, causing at least one of the clinical symptoms of the disease not to develop in a patient that may be exposed to or predisposed to the disease but does not yet experience or display symptoms of the disease. In some embodiments, “preventing” or “prevention” refers to reducing symptoms of the disease by taking the compound in a preventative fashion.

“Therapeutically effective amount” refers to the amount of a compound that, when administered to a patient for treating a disease, or at least one of the clinical symptoms of a disease, is sufficient to treat the disease or symptom thereof. A “therapeutically effective amount” may vary depending, for example, on the compound, the disease and/or symptoms of the disease, severity of the disease and/or symptoms of the disease or disorder, the age, weight, and/or health of the patient to be treated, and the judgment of a prescribing physician. An appropriate amount in any given instance may be ascertained by those skilled in the art or capable of determination by routine experimentation.

“Therapeutically effective dose” refers to a dose that provides effective treatment of a disease or disorder in a patient. A therapeutically effective dose may vary from compound to compound, and from patient to patient, and may depend upon factors such as the condition of the patient and the route of delivery. A therapeutically effective dose may be determined in accordance with routine pharmacological procedures known to those skilled in the art.

“Treating” or “treatment” of a disease refers to arresting or ameliorating a disease or at least one of the clinical symptoms of a disease or disorder, reducing the risk of acquiring a disease or at least one of the clinical symptoms of a disease, reducing the development of a disease or at least one of the clinical symptoms of the disease or reducing the risk of developing a disease or at least one of the clinical symptoms of a disease. “Treating” or “treatment” also refers to inhibiting the disease, either physically, (e.g., stabilization of a discernible symptom), physiologically, (e.g., stabilization of a physical parameter), or both, and to inhibiting at least one physical parameter or manifestation that may or may not be discernible to the patient. In certain embodiments, “treating” or “treatment” refers to delaying the onset of the disease or at least one or more symptoms thereof in a patient who may be exposed to or predisposed to a disease or disorder even though that patient does not yet experience or display symptoms of the disease.

“Fc”, “Fc region” or “Fc chain” refers to polypeptide comprising the constant region of an antibody, in some instances, excluding all or a portion of the first constant region immunoglobulin domain (e.g., CH1) or a portion thereof, and in some cases, further excluding all or a portion of the hinge. An Fc can refer to the last two constant region immunoglobulin domains (e.g., CH2 and CH3) of IgA, IgD, and IgG, the last three constant region immunoglobulin domains of IgE and IgM, and optionally, all or a portion of the flexible hinge N-terminal to these domains. For IgA and IgM, Fc may include the J chain. For IgG, the Fc chain comprises immunoglobulin domains CH2 and CH3 (Cy2 and Cy3), and optionally all or a portion of the hinge region between CH1 (Cy1) and CH2 (Cy2). Although the boundaries of the Fc region may vary, the human IgG heavy chain Fc region is usually defined to include from residues E216, C226, or A231 to its carboxyl-terminus. An amino acid modification can be made to the Fc region, for example, to

alter binding to one or more FcγR or to the FcRn. In EU numbering for human IgG1, the CH2-CH3 domain comprises amino acids 231 to 447, and the hinge comprises amino acids 216 to 230. Thus, the definition of Fc chain can include both amino acids 231-447 (CH2-CH3) or 216-447 (hinge-CH2-CH3), or fragments thereof. An Fc fragment can contain fewer amino acids from either or both of the N- and C-termini that retains the ability to form a dimer with another Fc chain or Fc fragment as can be detected using standard methods, generally based on size (e.g., non-denaturing chromatography, size exclusion chromatography, etc.). Human IgG-Fc fragments can be, for example, the Fc chain from human IgG1, human IgG2 or human IgG4.

“Heavy constant region” refers to the CH1-hinge-CH2-CH3 portion of an antibody or fragments thereof, excluding the variable heavy domain; in EU numbering of human IgG1, such as amino acids 118-447.

“Heavy chain constant region fragment” refers to a heavy chain constant region that contains fewer amino acids from either or both of the N- and C-termini that retains the ability to form a dimer with another heavy chain constant region.

“Immunoglobulin” refers to a protein having the structure of a naturally occurring antibody. For example, immunoglobulins of the IgG class are heterotetrameric glycoproteins of about 150,000 Da, having two light chains and two heavy chains that are bonded together through disulfide bonds. From N- to C-terminus, each heavy chain has a variable region (VH), also referred to as a variable heavy domain or a heavy chain variable domain, followed by three constant domains (CH1, CH2, and CH3), also called a heavy chain constant region. Similarly, from N- to C-terminus, each light chain has a variable region (VL), also referred to as a variable light domain or a light chain variable domain, followed by a constant light (CL) domain, also referred to as a light chain constant region. The heavy chain of an immunoglobulin may be assigned to one of five classes, called a (IgA), Ii (IgD), E (IgE), y (IgG), or μ (IgM), some of which may be further divided into subclasses, e.g., γ1 (IgG1), γ2 (IgG2), γ3 (IgG3), γ4(IgG4), α1 (IgA1) and α2 (IgA2). The light chain of an immunoglobulin may be assigned to one of two types, kappa (κ) or lambda (λ), based on the amino acid sequence of its constant domain. An immunoglobulin essentially consists of two Fab molecules and an Fc chain, linked via the immunoglobulin hinge region.

“Percent (%) sequence similarity” is determined by comparing the number of amino acids that are the same with respect to a reference peptide such as, for example, an IL-7Rα ligand, a Rγc ligand, an IL-7Rαγc ligand, or an IL-7Rαγc ligand IgG-Fc fusion protein. A peptide provided by the present disclosure can comprise, for example, greater than 70%, greater than 75%, greater than 80%, greater than 85%, greater than 90%, or greater than 95% sequence similarity to a reference peptide. For example, based on a reference peptide having SEQ ID NO: 201, peptides having SEQ ID NO: 202-207, have either 1, 2, 3, 4, or 5 amino acids in which an amino acid of the reference peptide has been substituted or replaced with the amino acid, alanine. Peptides having SEQ ID NO: 202-207 are characterized by a 95%, 90%, 85%, 80%, 75%, or 70% sequence similarity, respectively, to the reference peptide having SEQ ID NO: 201.

SEQ ID NO: 201
 Y P C W L A R V G E L C D L D S G D V H
 SEQ ID NO: 202
 A P C W L A R V G E L C D L D S G D V H
 SEQ ID NO: 203
 A P C A L A R V G E L C D L D S G D V H
 SEQ ID NO: 204
 A P C A L A A V G E L C D L D S G D V H
 SEQ ID NO: 205
 A P C A L A A V G A L C D L D S G D V H
 SEQ ID NO: 206
 A P C A L A A V G A L C D L A S G D V H
 SEQ ID NO: 207
 A P C A L A A V G A L C D L A A G D V H

An IL-7Rα ligand, a Rγc ligand, an IL-7Rαγc ligand, or an IL-7Rαγc IgG-Fc fusion protein provided by the present disclosure can have an amino acid sequence in which, for example, from 1 to 10 amino acids such as from 1 to 5 amino acids of a reference amino acid sequence are substituted with another amino acid.

For example, a reference ligand or reference IgG-Fc fusion protein can have from 1 to 10 amino acid substitutions, from 1 to 5 amino acid substitutions, from 1 to 4, from 1 to 3, or from 1 to 2 amino acid substitutions. For example, a reference ligand or reference IgG-Fc fusion protein can have 1 amino acid substitution, 2 amino acid substitutions, 3 amino acid substitutions, 4 amino acid substitutions, or 5 amino acid substitutions.

Each amino acid substitution can be independent each of the other amino acid substitutions.

Each amino acid substitution can independently be a conservative amino acid substitution or a non-conservative amino acid substitution.

For example, a reference peptide can have the amino acid sequence of SEQ ID NO: 211. Peptides having SEQ ID NO: 212-216 represent substituted peptides in which the reference peptide having SEQ ID NO: 211 has been substituted with from 1 to 5 amino acid substitutions, respectively.

SEQ ID NO: 211
 Y W C W M A Q V G E L C D L
 SEQ ID NO: 212
 Y H C W M A Q V G E L C D L
 SEQ ID NO: 213
 Y H C W M G Q V G E L C D L
 SEQ ID NO: 214
 Y H C W M G Q M G E L C D L
 SEQ ID NO: 215
 Y H C W M G Q M G E L C E L
 SEQ ID NO: 216
 Y H C W M G Q M G E L C E M

A peptide provided by the present disclosure can comprise an amino acid sequence in which from 1 to 3 glycines are independently bonded to the N-terminus, to the C-terminus, or to both the N-terminus and to the C-terminus of a reference peptide.

For example, a reference peptide can have SEQ ID NO: 220. Peptides having SEQ ID NO: 221-223 have from 1 to 3 glycines bonded to the N-terminus of the reference peptide, respectively; peptides having SEQ ID NO: 224-226

have from 1 to 3 glycines bonded to the C-terminus of the reference peptide, respectively; and peptides having SEQ ID NO: 227-228 independently have 1 or 2 glycines bonded to both the N-terminus and to the C-terminus of the reference peptide having SEQ ID NO: 220.

- K Y C G F A Q L G E L C V L SEQ ID NO: 220
- G K Y C G F A Q L G E L C V L SEQ ID NO: 221
- G G K Y C G F A Q L G E L C V L SEQ ID NO: 222
- G G G K Y C G F A Q L G E L C V L SEQ ID NO: 223
- K Y C G F A Q L G E L C V L G SEQ ID NO: 224
- K Y C G F A Q L G E L C V L G G SEQ ID NO: 225
- K Y C G F A Q L G E L C V L G G G SEQ ID NO: 226
- G K Y C G F A Q L G E L C V L G SEQ ID NO: 227
- G G K Y C G F A Q L G E L C V L G SEQ ID NO: 228

Reference is now made in detail to certain embodiments of compounds, compositions, and methods. The disclosed embodiments are not intended to be limiting of the claims. To the contrary, the claims are intended to cover all alternatives, modifications, and equivalents.

IL-7R α ligands provided by the present disclosure are hu-IL-7R agonists and cyno-IL-7R α agonists. IL-7R α IgG-Fc fusion proteins comprise an IL-7R α ligand bonded to the CH3 domain of the IgG-Fc fragments. The IL-7R α Fc fusion proteins are hu-IL-7R agonists and cyno-IL-7R agonists.

An IL-7R α ligand provided by the present disclosure comprises an IL-7R α ligand and an R γ C ligand.

An IL-7R α ligand provided by the present disclosure can comprise, for example, an amino acid sequence having SEQ ID NO: 1, an amino acid sequence having greater than 70% sequence similarity to an amino acid sequence having SEQ ID NO: 1, an amino acid sequence derived from SEQ ID NO: 1 having from 1 to 5 amino acid substitutions, or a combination of any of the foregoing.

- W G I P W C T L D P G S L Q C A W L G K H SEQ ID NO: 1

An IL-7R α ligand provided by the present disclosure can comprise an amino acid sequence having SEQ ID NO: 1.

An IL-7R α ligand provided by the present disclosure can comprise, for example, an amino acid sequence having greater than 70% sequence similarity to an amino acid sequence having SEQ ID NO: 1, greater than 75%, greater than 80%, greater than 85%, or greater than 90% sequence similarity to an amino acid sequence having SEQ ID NO: 1.

An IL-7R α ligand provided by the present disclosure can comprise, for example, an amino acid sequence derived from SEQ ID NO: 1 having from 1 to 5 amino acid substitutions, such as 1, 2, 3, 4 or 5 amino acid substitutions. Each of the from 1 to 5 amino acid substitutions can

independently be selected from a conservative amino acid substitution and a non-conservative amino acid substitution.

An IL-7R α ligand provided by the present disclosure can comprise, for example, from 0 to 5 glycines (G) on the C-terminus, on the N-terminus, or on both the C-terminus and the N-terminus. An IL-7R α ligand provided by the present disclosure can comprise, for example, 0, 1, 2, 3, 4, or 5 glycines (G) on the C-terminus, the N-terminus, or both the C-terminus and the N-terminus. The number of glycines (G) on the C-terminus and the N-terminus can be the same or can be different.

An IL-7R α ligand provided by the present disclosure can bind to the hu-IL-7R α subunit with an IC50, for example, of less than 10 μ M, less than 1 μ M, less than 100 nM, less than 10 nM, or less than 1 nM as determined using an ELISA binding assay.

An IL-7R α ligand provided by the present disclosure can competitively bind to a unique binding site of the hu-IL-7R α subunit with an IC50 less than 10 μ M, less than 1 μ M, less than 100 nM, less than 10 nM, or less than 1 nM as determined using an ELISA binding assay.

An IL-7R α ligand provided by the present disclosure can bind to the cyno-IL-7R α subunit with an IC50, for example, of less than 10 μ M, less than 1 μ M, less than 100 nM, less than 10 nM, or less than 1 nM as determined using an ELISA binding assay.

An R γ C ligand provided by the present disclosure can comprise an amino acid sequence having SEQ ID NO: 11, an amino acid sequence having greater than 70% sequence similarity to an amino acid sequence having SEQ ID NO: 11, greater than 75%, greater than 80%, greater than 85%, or greater than 90% sequence similarity to an amino acid sequence having SEQ ID NO: 11, an amino acid sequence derived from SEQ ID NO: 11 having from 1 to 5 amino acid substitutions, or a combination of any of the foregoing.

- V V C Q D W E G V E L C W Q SEQ ID NO: 11

An R γ C ligand provided by the present disclosure can comprise an amino acid sequence having SEQ ID NO: 11.

A R γ C ligand provided by the present disclosure can comprise, for example, an amino acid sequence having greater than 70% sequence similarity to an amino acid sequence having SEQ ID NO: 11, greater than 75%, greater than 80%, greater than 85%, or greater than 90% sequence similarity to an amino acid sequence having SEQ ID NO: 11.

An R γ C ligand provided by the present disclosure can comprise, for example, an amino acid sequence derived from SEQ ID NO: 11 having from 1 to 5 amino acid substitutions, such as 1, 2, 3, 4 or 5 amino acid substitutions. Each of the from 1 to 5 amino acid substitutions can independently be selected from a conservative amino acid substitution and a non-conservative amino acid substitution.

An R γ C ligand provided by the present disclosure can comprise, for example, from 0 to 5 glycines (G) on the C-terminus, the N-terminus, or both the C-terminus and the N-terminus. An R γ C ligand provided by the present disclosure can comprise, for example, 0, 1, 2, 3, 4, or 5 glycines (G) on the C-terminus, the N-terminus, or both the C-terminus and the N-terminus. The number of glycines (G) on the C-terminus and the N-terminus can be the same or different.

An R γ C ligand provided by the present disclosure can bind to the hu-IL-7R γ C subunit with an IC50, for example, less

11

than 10 μM , less than 1 μM , less than 100 nM, less than 10 nM, or less than 1 nM as determined using an ELISA binding assay.

An Ryc ligand provided by the present disclosure can competitively bind to a unique binding site on the hu-IL-7Ryc subunit with an IC50 less than 10 μM , less than 1 μM , less than 100 nM, less than 10 nM, or less than 1 nM as determined using an ELISA binding assay.

An Ryc ligand provided by the present disclosure can bind to the cyno-IL-7Ryc subunit with an IC50, for example, less than 10 μM , less than 1 μM , less than 100 nM, less than 10 nM, or less than 1 nM as determined using an ELISA binding assay.

An IL-7R α yc ligand provided by the present disclosure can comprise an IL-7R α ligand provided by the present disclosure and a Ryc ligand provided by the present disclosure.

For example, an IL-7R α yc ligand provided by the present disclosure can comprise an IL-7R α ligand of SEQ ID NO: 1 or an IL-7R α ligand having greater than 70% sequence similarity to SEQ ID NO: 1; and an Ryc ligand of SEQ ID NO: 11 or an Ryc ligand having greater than 70% sequence similarity to SEQ ID NO: 11.

In an IL-7R α yc ligand provided by the present disclosure, the IL-7R α ligand and the Ryc ligand can be bound together through a ligand linker.

For example, the C-terminus of the IL-7R α ligand can be bound to the N-terminus of the Ryc ligand through a ligand linker.

The ligand linker can be a rigid ligand linker or a flexible ligand linker.

Examples of suitable rigid ligand linkers include (P)_n, where n is an integer from 1 to 20 (SEQ ID NO: 101) such as from 5 to 15 (SEQ ID NO: 102); (PA)_n, where n is an integer from 1 to 20 (SEQ ID NO: 103) such as from 5 to 15 (SEQ ID NO: 104); (P)_nG where n is an integer from 1 to 20 (SEQ ID NO: 105) such as from 5 to 15 (SEQ ID NO: 106); (PA)_nG where n is an integer from 1 to 20 (SEQ ID NO: 107) such as from 5 to 15 (SEQ ID NO: 108); (P)_nGG where n is an integer from 1 to 20 (SEQ ID NO: 109) such as from 5 to 15 (SEQ ID NO: 110); and (PA)_nGG where n is an integer from 1 to 20 (SEQ ID NO: 111) such as from 5 to 15 (SEQ ID NO: 112).

Examples of suitable flexible ligand linkers include (G)_n, where n is an integer from 1 to 20 (SEQ ID NO: 113) such as from 1 to 15 (SEQ ID NO: 114); (GS)_n, where n is an integer from 1 to 20 (SEQ ID NO: 115) such as from 1 to 15 (SEQ ID NO: 116); (GGS)_n, where n is an integer from 1 to 20 (SEQ ID NO: 117) such as from 1 to 15 (SEQ ID NO: 118); (GGGS)_n, where n is an integer from 1 to 20 (SEQ ID NO: 119) such as from 1 to 15 (SEQ ID NO: 120); and (GGGGS)_n, where n is an integer from 1 to 20 (SEQ ID NO: 121) such as from 1 to 8 (SEQ ID NO: 122).

A flexible ligand linker can comprise (GGGGS)_n, where n is an integer from 1 to 10 (SEQ ID NO: 123), (GGGGS)_n, where n is an integer from 1 to 5 (SEQ ID NO: 124), (GGGGS)₁ (SEQ ID NO: 125), (GGGGS)₂ (SEQ ID NO: 126), (GGGGS)₃ (SEQ ID NO: 127), (GGGGS)₄ (SEQ ID NO: 128), or (GGGGS)₅ (SEQ ID NO: 129).

A flexible ligand linker can comprise (GGGGS)_nG where n is an integer from 1 to 10 (SEQ ID NO: 130), (GGGGS)_nG where n is an integer from 1 to 5 (SEQ ID NO: 131), (GGGGS)₁G (SEQ ID NO: 132), (GGGGS)₂G (SEQ ID NO: 133), (GGGGS)₃G (SEQ ID NO: 134), (GGGGS)₄G (SEQ ID NO: 135), or (GGGGS)₅G (SEQ ID NO: 136).

A flexible ligand linker can comprise (GGGGS)_nGG where n is an integer from 1 to 10 (SEQ ID NO: 137),

12

(GGGGS)_nGG where n is an integer from 1 to 5 (SEQ ID NO: 138), (GGGGS)₁GG (SEQ ID NO: 139), (GGGGS)₂GG (SEQ ID NO: 140), (GGGGS)₃GG (SEQ ID NO: 141), (GGGGS)₄GG (SEQ ID NO: 142), or (GGGGS)₅GG (SEQ ID NO: 143).

A ligand linker can have an amino acid sequence selected from any one of SEQ ID NO: 113-136. A ligand linker can have an amino acid sequence of SEQ ID NO: 132.

An IL-7R α yc ligand provided by the present disclosure can comprise an amino acid sequence of any one of SEQ ID NO: 21-32, where X¹ comprises a ligand linker, including, for example, any of the ligand linkers disclosed herein.

SEQ ID NO: 21
WGIPWCTLDPGSLQCAWLKGH-X¹-VVCQDWEGVELCWQ

SEQ ID NO: 22
GWGIPWCTLDPGSLQCAWLKGH-X¹-VVCQDWEGVELCWQ

SEQ ID NO: 23
WGIPWCTLDPGSLQCAWLKGH-X¹-VVCQDWEGVELCWQGG

SEQ ID NO: 24
GWGIPWCTLDPGSLQCAWLKGH-X¹-VVCQDWEGVELCWQGG

SEQ ID NO: 25
GGWIPWCTLDPGSLQCAWLKGH-X¹-VVCQDWEGVELCWQGG

SEQ ID NO: 26
GGGWPWCTLDPGSLQCAWLKGH-X¹-VVCQDWEGVELCWQGG

SEQ ID NO: 27
WGIPWCTLDPGSLQCAWLKGHGGGGGGVVCQDWEGVELCWQ

SEQ ID NO: 28
GWGIPWCTLDPGSLQCAWLKGHGGGGGGVVCQDWEGVELCWQ

SEQ ID NO: 29
WGIPWCTLDPGSLQCAWLKGHGGGGGGVVCQDWEGVELCWQGG

SEQ ID NO: 30
GWGIPWCTLDPGSLQCAWLKGHGGGGGGVVCQDWEGVELCWQGG

SEQ ID NO: 31
GGWIPWCTLDPGSLQCAWLKGHGGGGGGVVCQDWEGVELCWQGG

SEQ ID NO: 32
GGGWPWCTLDPGSLQCAWLKGHGGGGGGVVCQDWEGVELCWQGG

An IL-7R α yc ligand provided by the present disclosure can comprise an amino acid sequence having greater than 70% sequence similarity to any one of SEQ ID NO: 21-26, such as greater than 75%, greater than 80%, greater than 85%, greater than 90%, or greater than 95% sequence similarity to any one of SEQ ID NO: 21-26, where X¹ comprises a ligand linker, such as any of the ligand linkers disclosed herein.

An IL-7R α yc ligand provided by the present disclosure can comprise, for example, an amino acid sequence derived from any one of SEQ ID NO: 21-26 having from 1 to 5 amino acid substitutions, such as 1, 2, 3, 4 or 5 amino acid substitutions. Each of the from 1 to 5 amino acid substitutions can independently be selected from a conservative amino acid substitution and a non-conservative amino acid substitution. Each of the one or more of the amino acid substitutions can be a conservative amino acid substitution, and X¹ comprises a ligand linker, such as any of the ligand linkers disclosed herein.

An IL-7R α yc ligand provided by the present disclosure can comprise an amino acid sequence of any one of SEQ ID NO: 27-32.

An IL-7R α yc ligand provided by the present disclosure can comprise an amino acid sequence having greater than

70% sequence similarity to any one of SEQ ID NO: 27-32, such as greater than 75%, greater than 80%, greater than 85%, greater than 90%, or greater than 95% sequence similarity to any one of SEQ ID NO: 27-32.

An IL-7R α γ c ligand provided by the present disclosure can comprise, for example, an amino acid sequence derived from any one of SEQ ID NO: 27-32 having from 1 to 5 amino acid substitutions, such as 1, 2, 3, 4 or 5 amino acid substitutions. Each of the from 1 to 5 amino acid substitutions can independently be selected from a conservative amino acid substitution and a non-conservative amino acid substitution. Each of the one or more of the amino acid substitutions can be a conservative amino acid substitution.

An IL-7R α γ c ligand provided by the present disclosure can comprise an amino acid sequence of SEQ ID NO: 32.

An IL-7R α γ c ligand provided by the present disclosure can comprise an amino acid sequence having greater than 70% sequence similarity to SEQ ID NO: 32, such as greater than 75%, greater than 80%, greater than 85%, greater than 90%, or greater than 95% sequence similarity to SEQ ID NO: 32.

An IL-7R α γ c ligand provided by the present disclosure can comprise, for example, an amino acid sequence derived from SEQ ID NO: 32 having from 1 to 5 amino acid substitutions, such as 1, 2, 3, 4 or 5 amino acid substitutions. Each of the from 1 to 5 amino acid substitutions can independently be selected from a conservative amino acid substitution and a non-conservative amino acid substitution. Each of the one or more of the amino acid substitutions can be a conservative amino acid substitution.

An IL-7R α γ c ligand provided by the present disclosure can comprise, for example, from 0 to 5 glycines (G) on the C-terminus, on the N-terminus, or on both the C-terminus and the N-terminus. An IL-7R α γ c ligand provided by the present disclosure can comprise, for example, 0, 1, 2, 3, 4, or 5 glycines (G) on the C-terminus, on the N-terminus, or on both the C-terminus and the N-terminus. The number of glycines (G) on the C-terminus and the N-terminus of the IL-7R α γ c ligand can be the same or different.

An IL-7R α γ c ligand provided by the present disclosure can bind to the hu-IL-7R α subunit with an IC50 less than 10 μ M, less than 1 μ M, less than 100 nM, less than 10 nM, or less than 1 nM, as determined using an ELISA binding assay.

An IL-7R α γ c ligand provided by the present disclosure can bind to the hu-IL-7R γ c subunit with an IC50 less than 10 μ M, less than 1 μ M, less than 100 nM, less than 10 nM, or less than 1 nM, as determined using an ELISA binding assay.

For an IL-7R α γ c ligand provided by the present disclosure the ratio of the IC50 for binding to the hu-IL-7R α subunit to the hu-IL-7R γ c subunit can be, for example, from 100 to 1, from 50 to 2, or from 30 to 3.

For example, in an IL-7R α γ c ligand provided by the present disclosure, the IL-7R α γ c ligand can bind to the hu-IL-7R α subunit with an IC50 from 1 μ M to 10 μ M and can bind to the hu-IL-7R γ c subunit with an IC50 from 10 nM to 100 nM as determined using an ELISA binding assay.

An IL-7R α γ c ligand provided by the present disclosure can activate STAT5 phosphorylation in TF-1-7R α cells with an EC50, for example, of less than 1 μ M, less than 100 nM, less than 10 nM, or less than 1 nM.

An IL-7R α γ c ligand provided by the present disclosure can be a hu-IL-7R agonist.

An IL-7R α γ c ligand provided by the present disclosure can bind to the cyno-IL-7R α subunit with an IC50 less than

10 μ M, less than 1 μ M, less than 100 nM, less than 10 nM, or less than 1 nM as determined using an ELISA binding assay.

An IL-7R α γ c ligand provided by the present disclosure can bind to the cyno-IL-7R γ c subunit with an IC50 less than 10 μ M, less than 1 μ M, less than 100 nM, less than 10 nM, or less than 1 nM, as determined using an ELISA binding assay.

An IL-7R α γ c ligand provided by the present disclosure can be a cyno-IL-7R agonist.

An IL-7R α γ c ligand provided by the present disclosure can be a hu-IL-7R agonist and a cyno-IL-7R agonist.

An IL-7R α γ c IgG-Fc fusion protein provided by the present disclosure can comprise an IL-7R α γ c ligand provided by the present disclosure bound to an IgG-Fc fragment.

An IgG-Fc fragment can comprise, for example, a hu-IgG1 Fc fragment, a hu-IgG2-Fc fragment, or a hu-IgG4-Fc fragment. The hu-hIgG-Fc-fragment refers to the Fc region consisting of the CH2 and CH3 domains of the human hu-IgG heavy chain and the hinge region. The first and second cysteines of the hinge region can be replaced with serine to prevent detrimental disulfide bridges. The last amino acid of the Fc region such as the lysine of the hu-IgG2-Fc region can be replaced with an alanine for stability of the fusion protein.

An IL-7R α γ c ligand provided by the present disclosure can be bound to an IgG1 Fc fragment through a fusion linker such as an IgG-Fc linker.

An IgG-Fc linker can comprise a rigid IgG-Fc linker, a flexible IgG-Fc linker, or a combination of rigid and flexible IgG-Fc linker segments.

Examples of suitable rigid IgG-Fc linkers include linkers having SEQ ID NO: 113-136.

Examples of suitable flexible IgG-Fc linkers include linkers having SEQ ID NO: 101-112.

Examples of suitable flexible IgG-Fc linkers include (GS)_nGG where n is an integer from 1 to 20 (SEQ ID NO: 150) such as from 1 to 15 (SEQ ID NO: 151); (GGS)_nGG where n is an integer from 1 to 20 (SEQ ID NO: 152) such as from 1 to 15 (SEQ ID NO: 153); (GGGS)_nGG where n is an integer from 1 to 20 (SEQ ID NO: 154) such as from 1 to 15 (SEQ ID NO: 155); and (GGGG)_nGG where n is an integer from 1 to 20 (SEQ ID NO: 156) such as from 1 to 15 (SEQ ID NO: 157).

An IgG-Fc linker can comprise (GS)_n where n is an integer from 1 to 20 (SEQ ID NO: 115), such as from 5 to 15 (SEQ ID NO: 301). An IgG-Fc linker can comprise, for example, (GS)₅ (SEQ ID NO: 158), (GS)₆ (SEQ ID NO: 159), (GS)₇ (SEQ ID NO: 160), (GS)₈ (SEQ ID NO: 161), (GS)₉ (SEQ ID NO: 162), (GS)₁₀ (SEQ ID NO: 163), (GS)₁₁ (SEQ ID NO: 164), (GS)₁₂ (SEQ ID NO: 165), (GS)₁₃ (SEQ ID NO: 166), (GS)₁₄ (SEQ ID NO: 167), or (GS)₁₅ (SEQ ID NO: 168).

An IgG-Fc linker can comprise (GS)_nGG where n is an integer from 1 to 20 (SEQ ID NO: 150), such as from 1 to 15 (SEQ ID NO: 151). An IgG-Fc linker can comprise, for example, (GS)₅GG (SEQ ID NO: 169), (GS)₆GG (SEQ ID NO: 170), (GS)₇GG (SEQ ID NO: 171), (GS)₈GG (SEQ ID NO: 172), (GS)₉GG (SEQ ID NO: 173), (GS)₁₀GG (SEQ ID NO: 174), (GS)₁₁GG (SEQ ID NO: 175), (GS)₁₂GG (SEQ ID NO: 176), (GS)₁₃GG (SEQ ID NO: 177), (GS)₁₄GG (SEQ ID NO: 178), or (GS)₁₅GG (SEQ ID NO: 179).

An IgG-Fc linker can have an amino acid sequence of SEQ ID NO: 163.

The N-terminus of the IL-7R α γ c ligand can be bound to the IgG-Fc linker such as a linker having an amino acid

15

sequence of any one of SEQ ID NO: 150-179. The N-terminus of the IgG-Fc linker can be bound to the CH3 domain of the IgG-Fc fragment. An IL-7R α yc ligand can be bound to the C-terminus of one CH3 domain of the IgG-Fc fragment. An IL-7R α yc ligand can be bound to the C-terminus of each CH3 domain of the IgG-Fc fragment.

An IL-7R α yc ligand provided by the present disclosure can be bound to the CH3 domain of an IgG-Fc fragment through the IgG-Fc linker. For example, the N-terminus of the IL-7R α yc ligand can be bound to the C-terminus of a CH3 domain of an IgG-Fc fragment.

An IL-7R α yc IgG-Fc fusion protein provided by the present disclosure can comprise an IL-7R α yc ligand bound to a single CH3 domain of an IgG-Fc fragment, or an IL-7R α yc ligand can be bound to each CH3 domain of an IgG-Fc fragment.

The terminal amino acid of the IgG-Fc region such as the lysine of the IgG2-Fc region or a terminal replacement amino acid can be bound to the IL-7R α yc ligand through an IgG-Fc linker.

An IL-7R α yc ligand provided by the present disclosure can be bound to an IgG-Fc fragment through an IgG-Fc linker.

A schematic of an IL-7R α yc ligand IgG-Fc fusion protein provided by the present disclosure is shown in FIG. 4. As shown in FIG. 4 an IL-7R α yc ligand is bound to each CH3 domain of an IgG-Fc fragment. The IL-7R α yc ligand IgG-Fc fusion protein shown in FIG. 4 consists of two heavy chains comprising a CH2 domain and a CH3 domain where the hinge regions of the CH2 domains are bound by disulfide bonds and each IL-7R α yc ligand is bound to the C-terminus of a respective CH3 domain through an IgG-Fc linker.

An IgG-Fc fragment can comprise an amino acid sequence of any one of SEQ ID NO: 41-43, an amino acid sequence having greater than 70% sequence similarity to an amino acid sequence having any one of SEQ ID NO: 41-43, an amino acid sequence derived from any one of SEQ ID NO: 41-43 having from 1 to 10 amino acid substitutions, or a combination of any of the foregoing.

An IL-7R α yc IgG-Fc fusion fragment provided by the present disclosure can comprise an IL-7R α yc IgG-Fc fragment having any one of SEQ ID NO: 44-55, an amino acid sequence having greater than 70% sequence similarity to an amino acid sequence having any one of SEQ ID NO: 44-55, an amino acid sequence derived from any one of SEQ ID NO: 44-55 having from 1 to 10 amino acid substitutions, or a combination of any of the foregoing.

hu-IgG1-Fc (N297A mutant) SEQ ID NO: 41
 DKHTHTCPPCPAPELLGGPSVFLFPPKPKDTLMISRTPEVTCVVVDVSHED
 PEVKFNWYVDGVEVHNAKTKPREEQYASTYRVVSVLTVLHQDNLNG
 KEYKCKVSNKALPAPIEKTISKAKGQPREPQVYTLPPSRDELTKNQVSL
 TCLVKGFYPSDIAVEWESNGQPENNYKTPPVLDSDGSFFLYSKLTVDK
 SRWQQGNVFCSCVMHEALHNHYTQKSLSLSPGA
 hu-IgG2-F SEQ ID NO: 42
 ERKSVVECPAPPVAGPSVFLFPPKPKDTLMISRTPEVTCVVVDVSHED
 DPEVQFNWYVDGVEVHNAKTKPREEQFNSTFRVSVLTVVHQDNLN
 GKEYKCKVSNKGLPAPIEKTISKTKGQPREPQVYTLPPSREEMTKNQVS

16

-continued

LTCLVKGFYPSDIAVEWESNGQPENNYKTPPVLDSDGSFFLYSKLTVD
 KSRWQQGNVFCSCVMHEALHNHYTQKSLSLSPGA
 hu-IgG4-Fc SEQ ID NO: 43
 APPCPPCPAPEFEGGPSVFLFPPKPKDTLMISRTPEVTCVVVDVSDQEDPE
 VQFNWYVDGVEVHNAKTKPREEQFNSTYRVVSVLTVLHQDNLNGKE
 10 YKCKVSNKGLGSSIEKTIKAKGQPREPQVYTLPPSQEEMTKNQVSLTC
 LVKGFYPSDIAVEWESNGQPENNYKTPPVLDSDGSFFLYSRLTVDKSR
 WQEGNVFCSCVMHEALHNHYTQKSLSLGLGART
 hu-IgG1-Fc - (GS)₁₀GG-IL-7R α yc SEQ ID NO: 44
 DKHTHTCPPCPAPELLGGPSVFLFPPKPKDTLMISRTPEVTCVVVDVSHED
 PEVKFNWYVDGVEVHNAKTKPREEQYASTYRVVSVLTVLHQDNLNG
 20 KEYKCKVSNKALPAPIEKTISKAKGQPREPQVYTLPPSRDELTKNQVSL
 TCLVKGFYPSDIAVEWESNGQPENNYKTPPVLDSDGSFFLYSKLTVDK
 SRWQQGNVFCSCVMHEALHNHYTQKSLSLSPGAGSGSGSGSGSGSGSG
 25 SGSGSGGGWGI PWCTLDPGSLQCAWLKKGSGSGGGVVCQDWEWGE
 LCWQGG
 hu-IgG2-Fc - (GS)₁₀GG-IL-7R α yc SEQ ID NO: 45
 ERKSVVECPAPPVAGPSVFLFPPKPKDTLMISRTPEVTCVVVDVSHED
 DPEVQFNWYVDGVEVHNAKTKPREEQFNSTFRVSVLTVVHQDNLN
 GKEYKCKVSNKGLPAPIEKTISKTKGQPREPQVYTLPPSREEMTKNQVS
 35 LTCLVKGFYPSDIAVEWESNGQPENNYKTPPVLDSDGSFFLYSKLTVD
 KSRWQQGNVFCSCVMHEALHNHYTQKSLSLSPGAGSGSGSGSGSGSGS
 GSGSGSGGGWGI PWCTLDPGSLQCAWLKKGSGSGGGVVCQDWEWGE
 ELCWQGG
 hu-IgG4-Fc - (GS)₁₀GG-IL-7R α yc SEQ ID NO: 46
 APPCPPCPAPEFEGGPSVFLFPPKPKDTLMISRTPEVTCVVVDVSDQEDPE
 VQFNWYVDGVEVHNAKTKPREEQFNSTYRVVSVLTVLHQDNLNGKE
 45 YKCKVSNKGLGSSIEKTIKAKGQPREPQVYTLPPSQEEMTKNQVSLTC
 LVKGFYPSDIAVEWESNGQPENNYKTPPVLDSDGSFFLYSRLTVDKSR
 WQEGNVFCSCVMHEALHNHYTQKSLSLGLGARTGSGSGSGSGSGSGS
 50 SGSGSGGGWGI PWCTLDPGSLQCAWLKKGSGSGGGVVCQDWEWGE
 LCWQGG
 hu-IgG1-Fc - X²-IL-7R α yc SEQ ID NO: 47
 DKHTHTCPPCPAPELLGGPSVFLFPPKPKDTLMISRTPEVTCVVVDVSHED
 PEVKFNWYVDGVEVHNAKTKPREEQYASTYRVVSVLTVLHQDNLNG
 KEYKCKVSNKALPAPIEKTISKAKGQPREPQVYTLPPSRDELTKNQVSL
 60 TCLVKGFYPSDIAVEWESNGQPENNYKTPPVLDSDGSFFLYSKLTVDK
 SRWQQGNVFCSCVMHEALHNHYTQKSLSLSPGA-X²-
 GGGWGI PWCTLDPGSLQCAWLKKGSGSGGGVVCQDWEWGEVLCWQ
 65 GGS

-continued

hu-IgG2-Fc-X²-IL-7Rαc
 SEQ ID NO: 48
 ERKSSVECPPCAPPVAGPSVFLFPPKPKDTLMISRTPEVTCVVVDVSHED
 DPEVQFNWYVDGVEVHNAKTKPREEQFNSTFRVSVLTVVHQDNLN
 GKEYKCKVSNKGLPAPIEKTI SKTKGQPREPQVYTLPPSREEMTKNQVS
 LTCLVKGFYPSDIAVEWESNGQPENNYKTPPMLDSGSGFFLYSKLTVD
 KSRWQQGNVFCSCVMHEALHNHYTQKSLSLSPGA-X²-
 GGGWGI PWCTLDPGSLQCAWLKKGHGGGGSGGVVVCQDWEVLCWQG
 GG

hu-IgG4-Fc-X²-IL-7Rαc
 SEQ ID NO: 49
 APPCPPCPAPEFEGGPSVFLFPPKPKDTLMISRTPEVTCVVVDVSDPE
 VQFNWYVDGVEVHNAKTKPREEQFNSTYRVVSVLTVLHQDNLNKE
 YKCKVSNKGLGSSIEKTI SKAKGQPREPQVYTLPPSQEEMTKNQVSLTC
 LVKGFYPSDIAVEWESNGQPENNYKTPPVLDSDGSGFFLYSRLTVDKSR
 WQEGNVFSCVMHEALHNHYTQKSLSLSLGART-X²-
 GGGWGI PWCTLDPGSLQCAWLKKGHGGGGSGGVVVCQDWEVLCWQG
 GG

hu-IgG1-Fc-(GS)₁₀GG-IL-7Rαc
 SEQ ID NO: 50
 DKHTHTCPPCPAPPELLGGPSVFLFPPKPKDTLMISRTPEVTCVVVDVSHED
 PEVKFNWYVDGVEVHNAKTKPREEQYASTYRVVSVLTVLHQDNLN
 KEYKCKVSNKALPAPIEKTI SKAKGQPREPQVYTLPPSRDELTKNQVSL
 TCLVKGFYPSDIAVEWESNGQPENNYKTPPVLDSDGSGFFLYSKLTVDK
 SRWQQGNVFCSCVMHEALHNHYTQKSLSLSPGAGSGSGSGSGSGSGSG
 SGSGSGGGWGI PWCTLDPGSLQCAWLKGH-X¹-
 VVCQDWEVLCWQGG

hu-IgG2-Fc-(GS)₁₀GG-IL-7Rαc
 SEQ ID NO: 51
 ERKSSVECPPCAPPVAGPSVFLFPPKPKDTLMISRTPEVTCVVVDVSHED
 DPEVQFNWYVDGVEVHNAKTKPREEQFNSTFRVSVLTVVHQDNLN
 GKEYKCKVSNKGLPAPIEKTI SKTKGQPREPQVYTLPPSREEMTKNQVS
 LTCLVKGFYPSDIAVEWESNGQPENNYKTPPMLDSGSGFFLYSKLTVD
 KSRWQQGNVFCSCVMHEALHNHYTQKSLSLSPGAGSGSGSGSGSGSGSG
 GSGSGGGWGI PWCTLDPGSLQCAWLKGH-X¹-
 VVCQDWEVLCWQGG

hu-IgG1-Fc-(GS)₁₀GG-IL-7Rαc
 SEQ ID NO: 52
 APPCPPCPAPEFEGGPSVFLFPPKPKDTLMISRTPEVTCVVVDVSDPE
 VQFNWYVDGVEVHNAKTKPREEQFNSTYRVVSVLTVLHQDNLNKE
 YKCKVSNKGLGSSIEKTI SKAKGQPREPQVYTLPPSQEEMTKNQVSLTC
 LVKGFYPSDIAVEWESNGQPENNYKTPPVLDSDGSGFFLYSRLTVDKSR
 WQEGNVFSCVMHEALHNHYTQKSLSLSLGARTGSGSGSGSGSGSGSGSG
 SGSGSGGGWGI PWCTLDPGSLQCAWLKGH-X¹-
 VVCQDWEVLCWQGG

-continued

hu-IgG1-Fc-X²-IL-7Rαc
 SEQ ID NO: 53
 DKHTHTCPPCPAPPELLGGPSVFLFPPKPKDTLMISRTPEVTCVVVDVSHED
 5 PEVKFNWYVDGVEVHNAKTKPREEQYASTYRVVSVLTVLHQDNLN
 KEYKCKVSNKALPAPIEKTI SKAKGQPREPQVYTLPPSRDELTKNQVSL
 TCLVKGFYPSDIAVEWESNGQPENNYKTPPVLDSDGSGFFLYSKLTVDK
 10 SRWQQGNVFCSCVMHEALHNHYTQKSLSLSPGA-X²-
 GGGWGI PWCTLDPGSLQCAWLKGH-X¹-VVCQDWEVLCWQGG
 hu-IgG2-Fc-X²-IL-7Rαc
 SEQ ID NO: 54
 15 ERKSSVECPPCAPPVAGPSVFLFPPKPKDTLMISRTPEVTCVVVDVSHED
 DPEVQFNWYVDGVEVHNAKTKPREEQFNSTFRVSVLTVVHQDNLN
 GKEYKCKVSNKGLPAPIEKTI SKTKGQPREPQVYTLPPSREEMTKNQVS
 LTCLVKGFYPSDIAVEWESNGQPENNYKTPPMLDSGSGFFLYSKLTVD
 20 KSRWQQGNVFCSCVMHEALHNHYTQKSLSLSPAGA-X²-
 GGGWGI PWCTLDPGSLQCAWLKGH-X¹-VVCQDWEVLCWQGG
 hu-IgG4-Fc-X²-IL-7Rαc
 SEQ ID NO: 55
 25 APPCPPCPAPEFEGGPSVFLFPPKPKDTLMISRTPEVTCVVVDVSDPE
 VQFNWYVDGVEVHNAKTKPREEQFNSTYRVVSVLTVLHQDNLNKE
 YKCKVSNKGLGSSIEKTI SKAKGQPREPQVYTLPPSQEEMTKNQVSLTC
 30 LVKGFYPSDIAVEWESNGQPENNYKTPPVLDSDGSGFFLYSRLTVDKSR
 WQEGNVFSCVMHEALHNHYTQKSLSLSLGART-X²-
 GGGWGI PWCTLDPGSLQCAWLKGH-X¹-VVCQDWEVLCWQGG
 35 In an IL-7Rαc IgG-Fc fusion fragment having SEQ ID
 NO: 47-55, X¹ can be a ligand linker as disclosed herein and
 X² can be an IgG-Fc linker as disclosed herein.
 An IL-7Rαc IgG-Fc fusion fragment provided by the
 40 present disclosure can comprise an amino acid sequence
 having any one of SEQ ID NO: 44-55.
 An IL-7Rαc IgG-Fc fusion fragment provided by the
 present disclosure can comprise, for example, an amino acid
 sequence having greater than 70% sequence similarity to an
 45 amino acid sequence having any one of SEQ ID NO: 44-55,
 greater than 75%, greater than 80%, greater than 85%,
 greater than 90%, or greater than 95% sequence similarity to
 an amino acid sequence having any one of SEQ ID NO:
 44-55.
 50 An IL-7Rαc IgG-Fc fusion fragment provided by the
 present disclosure can comprise, for example, an amino acid
 sequence derived from any one of SEQ ID NO: 44-55
 having from 1 to 10 amino acid substitutions, such as from
 1 to 5 amino acid substitutions, such as 1, 2, 3, 4 or 5 amino
 acid substitutions. Each of the from 1 to 10 amino acid
 55 substitutions can independently be selected from a conser-
 vative amino acid substitution and a non-non-conservative
 amino acid substitution. Each of the one or more of the
 amino acid substitutions can be a conservative amino acid
 60 substitution.
 An IL-7Rαc IgG-Fc fusion fragment provided by the
 present disclosure can bind to the hu-IL-7Rα subunit with an
 IC50 less than 10 μM, less than 1 μM, less than 100 nM, less
 than 10 nM, or less than 1 nM, as determined using an
 65 ELISA binding assay.
 An IL-7Rαc IgG-Fc fusion fragment provided by the
 present disclosure can bind to the hu-Rγc subunit with an

IC50 less than 10 μ M, less than 1 μ M, less than 100 nM, less than 10 nM, or less than 1 nM, as determined using an ELISA binding assay.

An IL-7R α γ c IgG-Fc fusion fragment provided by the present disclosure can bind to a unique binding site on hu-IL-7R with an IC50 less than 10 μ M, less than 1 μ M, less than 100 nM, less than 10 nM, or less than 1 nM, as determined using an ELISA binding assay.

For an IL-7R α γ c IgG-Fc fusion fragment provided by the present disclosure the ratio of the IC50 for binding to the hu-IL-7R α subunit to the hu-IL-7R γ c subunit can be, for example, from 100 to 1, or from 30 to 3, where binding is determined using an ELISA binding assay.

For an IL-7R α γ c IgG-Fc fusion fragment provided by the present disclosure the ratio of the IC50 for binding to the hu-IL-7R α subunit to the hu-IL-7R γ c subunit can be, for example, greater than 1, greater than 3, greater than 10, greater than 30, greater than 100, or greater than 300, where binding is determined using an ELISA binding assay.

For example, in an IL-7R α γ c IgG-Fc fusion fragment provided by the present disclosure, the IL-7R α γ c ligand can bind to the hu-IL-7R α subunit with an IC50 from 1 μ M to 10 μ M and can bind to the hu-IL-7R γ c subunit with an IC50 from 10 nM to 100 nM, as determined using an ELISA binding assay.

An IL-7R α γ c IgG-Fc fusion fragment provided by the present disclosure can activate STAT5 phosphorylation in TF-1-7R α cells with an EC50 less than 1 μ M, less than 100 nM, less than 10 nM, or less than 1 nM.

An IL-7R α γ c IgG-Fc fusion fragment provided by the present disclosure can be a hu-IL-7R agonist.

An IL-7R α γ c IgG-Fc fusion fragment provided by the present disclosure can be a hu-IL-7R agonist and a cyno-IL-7R agonist.

An IL-7R α γ c IgG-Fc fusion protein provided by the present disclosure can comprise two IL-7R α γ c IgG-Fc fusion fragments provided by the present disclosure such as an IL-7R α γ c IgG-Fc fragment having any one of SEQ ID NO: 44-55, an amino acid sequence having greater than 70% sequence similarity to an amino acid sequence having any one of SEQ ID NO: 44-55, an amino acid sequence derived from any one of SEQ ID NO: 44-55 having from 1 to 10 amino acid substitutions, or a combination of any of the foregoing.

An IL-7R α γ c IgG-Fc fusion protein provided by the present disclosure can comprise two IL-7R α γ c IgG-Fc fragments provided by the present disclosure such as any of the IL-7R α γ c IgG-Fc fragments having SEQ ID NO: 44-55 bound together at the hinge region through one or more disulfide bonds.

Each of the IL-7R α γ c IgG-Fc fragments of an IL-7R α γ c IgG-Fc fusion protein can be the same IL-7R α γ c IgG-Fc fragment provided by the present disclosure.

Each of the IL-7R α γ c IgG-Fc fragments of an IL-7R α γ c IgG-Fc fusion protein can comprise a different IL-7R α ligand, a different R γ c ligand, a different IL-7R α γ c linker, a different IL-7R α γ c ligand, a different IgG-Fc fragment, a different IgG-Fc linker, or a combination of any of the foregoing.

An IL-7R α γ c IgG-Fc fusion protein provided by the present disclosure can bind to the hu-IL-7R α subunit with an IC50 less than 10 μ M, less than 1 μ M, less than 100 nM, less than 10 nM, or less than 1 nM, as determined using an ELISA binding assay.

An IL-7R α γ c IgG-Fc fusion protein provided by the present disclosure can bind to the hu-R γ c subunit with an

IC50 less than 10 μ M, less than 1 μ M, less than 100 nM, less than 10 nM, or less than 1 nM, as determined using an ELISA binding assay.

An IL-7R α γ c IgG-Fc fusion protein provided by the present disclosure can bind to a unique binding site on hu-IL-7R with an IC50 less than 10 μ M, less than 1 μ M, less than 100 nM, less than 10 nM, or less than 1 nM, as determined using an ELISA binding assay.

For an IL-7R α γ c IgG-Fc fusion protein provided by the present disclosure the ratio of the IC50 for binding to the hu-IL-7R α subunit to the hu-IL-7R γ c subunit can be, for example, from 100 to 1, or from 30 to 3, where binding is determined using an ELISA binding assay.

For an IL-7R α γ c IgG-Fc fusion protein provided by the present disclosure the ratio of the IC50 for binding to the hu-IL-7R α subunit to the hu-IL-7R γ c subunit can be, for example, greater than 1, greater than 3, greater than 10, greater than 30, greater than 100, or greater than 300, where binding is determined using an ELISA binding assay.

For example, in an IL-7R α γ c IgG-Fc fusion protein provided by the present disclosure, the IL-7R α γ c ligand can bind to the hu-IL-7R α subunit with an IC50 from 1 μ M to 10 μ M and can bind to the hu-IL-7R γ c subunit with an IC50 from 10 nM to 100 nM, as determined using an ELISA binding assay.

An IL-7R α γ c IgG-Fc fusion protein provided by the present disclosure can activate STAT5 phosphorylation in TF-1-7R α cells with an EC50 less than 1 μ M, less than 100 nM, less than 10 nM, or less than 1 nM.

An IL-7R α γ c IgG-Fc fusion protein provided by the present disclosure can be a hu-IL-7R agonist.

An IL-7R α γ c IgG-Fc fusion protein provided by the present disclosure can competitively bind to the cyno-IL-7R α subunit with an IC50 less than 10 μ M, less than 1 μ M, less than 100 nM, less than 10 nM, or less than 1 nM, as determined using an ELISA binding assay.

An IL-7R α γ c IgG-Fc fusion protein provided by the present disclosure can competitively bind to the cyno-IL-7R γ c subunit with an IC50 less than 10 less than 1 μ M, less than 100 nM, less than 10 nM, or less than 1 nM, as determined using an ELISA binding assay.

An IL-7R α γ c IgG-Fc fusion protein provided by the present disclosure can be a cyno-IL-7R agonist.

An IL-7R α γ c IgG-Fc fusion protein provided by the present disclosure can be a hu-IL-7R agonist and a cyno-IL-7R agonist.

A pharmaceutical composition provided by the present disclosure can comprise an IL-7R α γ c ligand provided by the present disclosure, an IL-7R α γ c IgG-Fc fusion protein provided by the present disclosure, or a combination thereof.

An IL-7R α γ c ligand and/or IL-7R α γ c IgG-Fc fusion protein provided by the present disclosure, can be incorporated into a pharmaceutical composition to be administered to a patient by any appropriate route of administration including intradermal, intramuscular, intraperitoneal, intravenous, subcutaneous, intranasal, epidural, oral, peroral, sublingual, intracerebral, intravaginal, transdermal, rectal, inhalation, or topical. A pharmaceutical composition provided by the present disclosure can be an injectable formulation. A pharmaceutical composition provided by the present disclosure can be an injectable intravenous formulation. A pharmaceutical composition provided by the present disclosure can be an oral formulation. Oral formulations may be oral dosage forms. A pharmaceutical composition can be formulated for intravenous administration or for subcutaneous administration.

A pharmaceutical composition provided by the present disclosure can comprise a therapeutically effective amount of an IL-7R α γ c ligand and/or IL-7R α γ c IgG-Fc fusion protein together with a suitable amount of one or more pharmaceutically acceptable vehicles so as to provide a composition for administration to a patient. Suitable pharmaceutical vehicles and methods of preparing pharmaceutical compositions are described in the art.

An IL-7R α γ c ligand and/or IL-7R α γ c IgG-Fc fusion protein and pharmaceutical composition thereof can be used in an amount effective to achieve an intended purpose such as to treat a disease such as cancer, an autoimmune disease, an inflammatory disease, or a viral disease. For use to treat a disease such as cancer, an autoimmune disease, an inflammatory disease, or a viral disease, an IL-7R α γ c ligand and/or IL-7R α γ c IgG-Fc fusion or pharmaceutical composition thereof, can be administered or applied in a therapeutically effective amount.

The amount of an IL-7R α γ c ligand and/or IL-7R α γ c IgG-Fc fusion protein or pharmaceutical composition thereof that will be effective in the treatment of a particular disease, disorder or condition can depend in part on the nature of the disease, disorder or condition, and can be determined by standard clinical techniques known in the art. In addition, *in vitro* or *in vivo* assays can be employed to help identify optimal dosage ranges. The amount of an IL-7R α γ c ligand and/or IL-7R α γ c IgG-Fc fusion protein or pharmaceutical composition administered can depend, for example, on the patient being treated, the weight of the patient, the severity of the disease, the manner of administration and the judgment of the prescribing physician.

An IL-7R α γ c ligand and/or IL-7R α γ c IgG-Fc fusion protein can be assayed *in vitro* and *in vivo*, for the desired therapeutic activity, prior to use in humans. For example, *in vitro* assays may be used to determine whether administration of a specific compound or a combination of compounds is preferred. The compounds can also be demonstrated to be effective and safe using animal model systems.

A therapeutically effective dose of an IL-7R α γ c ligand and/or IL-7R α γ c IgG-Fc fusion protein or pharmaceutical composition thereof can provide therapeutic benefit without causing substantial toxicity. Toxicity of an IL-7R α γ c ligand and/or IL-7R α γ c IgG-Fc fusion protein or pharmaceutical compositions thereof can be determined using standard pharmaceutical procedures. The dose ratio between toxic and therapeutic effect is the therapeutic index. An IL-7R α γ c ligand and/or IL-7R α γ c IgG-Fc fusion protein or pharmaceutical composition thereof can exhibit a high therapeutic index in treating certain diseases and disorders. A dose of an IL-7R α γ c ligand and/or IL-7R α γ c IgG-Fc fusion protein or pharmaceutical composition thereof can be within a range of circulating plasma concentrations that reflect a therapeutically effective dose with minimal toxicity.

An IL-7R α γ c ligand and/or IL-7R α γ c IgG-Fc fusion protein provided by the present disclosure, or a pharmaceutical composition thereof may be included in a kit that can be used to administer the peptide to a patient for therapeutic purposes. A kit can include a pharmaceutical composition comprising an IL-7R α γ c ligand and/or IL-7R α γ c IgG-Fc fusion protein provided by the present disclosure suitable for administration to a patient and instructions for administering the pharmaceutical composition to the patient. The kit can be a kit for treating cancer, for treating an autoimmune disease, for treating an inflammatory disease, or for treating a viral disease. For example, a kit for use in treating cancer, an autoimmune disease, an inflammatory disease, an immunodeficiency disease, or a viral disease in a patient can com-

prise an IL-7R α γ c ligand and/or IL-7R α γ c IgG-Fc fusion protein provided by the present disclosure, a pharmaceutically acceptable vehicle for administering the compound, and instructions for administering the compound to a patient.

A pharmaceutical composition can be included in a container, pack, or dispenser together with instructions for administration to a patient.

Instructions supplied with a kit can be provided in a written or electronic format.

An IL-7R α γ c ligand or IL-7R α γ c IgG-Fc fusion protein provided by the present disclosure can be used, for example, to treat diseases such as cancer, an inflammatory disease, an autoimmune disease, an immunodeficiency disease, or a viral disease such as COVID-19.

A method provided by the present disclosure can comprise treating a disease in a patient such as cancer, an inflammatory disease, an autoimmune disease, an immunodeficiency disease, or a viral disease comprising administering to a patient in need of such treatment a therapeutically effective amount of an IL-7R α γ c ligand or IL-7R α γ c IgG-Fc fusion protein provided by the present disclosure or pharmaceutical composition thereof.

An IL-7R α γ c ligand or IL-7R α γ c IgG-Fc fusion protein provided by the present disclosure can be used for treating cancer in a patient. The cancer can be, for example, a solid tumor or a metastasis.

An IL-7R α γ c ligand or IL-7R α γ c IgG-Fc fusion protein provided by the present disclosure or pharmaceutical compositions thereof can be used to treat, for example, one or more of the following cancers: acute lymphoblastic leukemia, acute myeloid leukemia, adrenocortical carcinoma, appendix cancer, astrocytoma, atypical teratoid/rhabdoid tumor, basal cell carcinoma (nonmelanoma), B-cell lymphoma, bladder cancer, bone cancer, brain and spinal cord tumors, brain stem cancer, brain tumor, breast cancer, bronchial tumors, Burkitt lymphoma, carcinoid tumor, carcinoma of head and neck, central nervous system embryonal tumors, cerebellar astrocytoma, cerebral astrocytoma/malignant glioma, cervical cancer, chordoma, chronic lymphocytic leukemia, chronic myelogenous leukemia, colorectal cancer, craniopharyngioma, cutaneous T-cell lymphoma, desmoplastic small round cell tumor, ductal carcinoma, dye cancer, endocrine pancreas tumors (islet cell tumors), endometrial cancer, ependymoblastoma, esophageal cancer, esthesioneuroblastoma, Ewing family of tumors, extracranial germ cell tumor, extrahepatic bile duct cancer, gallbladder cancer, gastric cancer, gastrointestinal carcinoid tumor, gastrointestinal stromal tumor, gestational trophoblastic tumor, glioblastoma, glioma, hairy cell leukemia, head and neck cancer, heart cancer, hematopoietic tumors of the lymphoid lineage, hepatocellular cancer, Hodgkin lymphoma, hypopharyngeal cancer, hypothalamic and visual pathway glioma, IDs-related lymphoma, intraocular melanoma, islet cell tumors, Kaposi sarcoma, kidney cancer, Langerhans cell histiocytosis, laryngeal cancer, leukemia, lip and oral cavity cancer, male breast cancer, malignant fibrous histiocytoma, malignant germ cell tumors, malignant mesothelioma, medulloblastoma, melanoma, Merkel cell carcinoma, mesothelioma, mouth cancer, multiple endocrine neoplasia syndrome, multiple myeloma, mycosis fungoides, myelodysplastic, myeloproliferative neoplasms, nasal cavity and paranasal sinus cancer, nasopharyngeal cancer, neuroblastoma, non-Hodgkin lymphoma, non-small cell lung cancer, oral cancer, oropharyngeal cancer, osteosarcoma, ovarian cancer, ovarian epithelial cancer, ovarian germ cell tumor, ovarian low malignant potential tumor, pancreatic cancer,

pancreatic neuroendocrine tumors (islet cell tumors), papillomatosis, paraganglioma, paranasal sinus and nasal cavity cancer, parathyroid cancer, penile cancer, pharyngeal cancer, pheochromocytoma, pineal parenchymal tumors, pineoblastoma and supratentorial primitive neuroectodermal tumors, pituitary tumor, plasma cell neoplasm/multiple myeloma, pleuropulmonary blastoma, pregnancy and breast cancer, primary central nervous system lymphoma, primary liver cancer, primary metastatic squamous neck cancer with occult, prostate cancer, rectal cancer, renal cell cancer, renal pelvis and ureter, respiratory tract carcinoma, retinoblastoma, rhabdomyosarcoma, salivary gland cancer, sarcoma, Sézary syndrome, skin cancer, small intestine cancer, soft tissue sarcoma, squamous cell carcinoma (nonmelanoma), stomach cancer, supratentorial primitive neuroectodermal tumors, T-cell lymphoma, testicular cancer, throat cancer, thymoma and thymic carcinoma, thyroid cancer, transitional cell cancer, urethral cancer, uterine sarcoma, vaginal cancer, visual pathway and hypothalamic glioma, vulvar cancer, Waldenström macroglobulinemia, Wilms tumor, and systemic and central metastases of any of the foregoing.

An IL-7R $\alpha\gamma$ ligand or IL-7R $\alpha\gamma$ IgG-Fc fusion protein provided by the present disclosure, or a pharmaceutical composition thereof can be used to treat solid tumors.

An IL-7R $\alpha\gamma$ ligand or IL-7R $\alpha\gamma$ IgG-Fc fusion protein provided by the present disclosure, or a pharmaceutical composition thereof can be used to treat tumor metastases. An IL-7R $\alpha\gamma$ ligand or IL-7R $\alpha\gamma$ IgG-Fc fusion protein provided by the present disclosure, or a pharmaceutical composition thereof can be used to treat circulating tumor cells.

An IL-7R $\alpha\gamma$ ligand or IL-7R $\alpha\gamma$ IgG-Fc fusion protein provided by the present disclosure or pharmaceutical compositions thereof can be used to treat, for example, a cancer selected from primary adult and childhood brain and CNS cancers including glioblastoma (GBM) and astrocytoma, skin cancers including melanoma, lung cancers including small cell lung cancers, non-small cell lung cancers (NSCLC), and large cell lung cancers, breast cancers including triple negative breast cancer (TNBC), blood cancers including myelodysplastic syndrome (MDS), multiple myeloma (MM), and acute myeloid leukemia (AML), prostate cancer including castrate resistant prostate cancer (CRPC), liver cancers including hepatocellular carcinoma (HCC), esophageal and gastric cancers, and any systemic and central metastases of any of the foregoing.

An IL-7R $\alpha\gamma$ ligand or IL-7R $\alpha\gamma$ IgG-Fc fusion protein provided by the present disclosure can be used, for example, in combination with temozolomide to treat glioblastoma, with atezolizumab to treat skin cancers such as MCC, C5CC and melanoma, with pembrolizumab to treat triple-negative breast cancer, and in combination with CAR-T therapy to treat pediatric acute lymphoblastic leukemia.

An IL-7R $\alpha\gamma$ ligand or IL-7R $\alpha\gamma$ IgG-Fc fusion protein provided by the present disclosure, or a pharmaceutical composition thereof can be administered to a patient in need of such treatment to treat an inflammatory disease.

Examples of inflammatory diseases include allergy, Alzheimer's disease, anemia, ankylosing spondylitis, arthritis, atherosclerosis, asthma, autism, arthritis, carpal tunnel syndrome, celiac disease, colitis, Crohn's disease, congestive heart failure, dermatitis, diabetes, diverticulitis, eczema, fibromyalgia, fibrosis, gall bladder disease gastroesophageal reflux disease, Hashimoto's thyroiditis, heart attack, hepatitis, irritable bowel syndrome, kidney failure, lupus, multiple sclerosis, nephritis, neuropathy, pancreatitis, Parkinson's disease, psoriasis, polymyalgia rheumatica,

rheumatoid arthritis, scleroderma, stroke, surgical complications, and ulcerative colitis.

An IL-7R $\alpha\gamma$ ligand or IL-7R $\alpha\gamma$ IgG-Fc fusion protein provided by the present disclosure, or a pharmaceutical composition thereof can be useful in treating autoimmune diseases. Autoimmune diseases can be defined as human diseases in which the immune system attacks its own proteins, cells, and/or tissues. A comprehensive listing and review of autoimmune diseases can be found, for example, in *The Autoimmune Diseases*, Rose and Mackay, 2014, Academic Press.

An IL-7R $\alpha\gamma$ ligand or IL-7R $\alpha\gamma$ IgG-Fc fusion protein provided by the present disclosure, or a pharmaceutical composition thereof can be administered to a patient to treat an autoimmune disease.

Examples of autoimmune diseases include Addison's disease, agammaglobulinemia, alopecia areata, amyloidosis, ankylosing spondylitis, anti-GBM/anti-TBN nephritis, antiphospholipid syndrome, autoimmune angioedema, autoimmune dysautonomia, autoimmune encephalomyelitis, autoimmune hepatitis, autoimmune inner ear disease, autoimmune myocarditis, autoimmune pancreatitis, autoimmune retinopathy, autoimmune urticaria, axonal and neuronal neuropathy, Balo's disease, Bechet's disease, benign mucosal pemphigoid, bullous pemphigoid, Castleman disease, celiac disease, Chagas disease, chronic inflammatory demyelinating polyneuropathy, chronic recurrent multifocal osteomyelitis, Churg-Strauss, cicatricial pemphigoid, Cogan's syndrome, cold agglutinin disease, congenital heart block, Cocksackie myocarditis, CREST syndrome, Crohn's disease, dermatitis herpetiformis, dermatomyositis, Devic's disease, discoid lupus, Dressler's syndrome, endometriosis, eosinophilic esophagitis, eosinophilic fasciitis, erythema nodosum, essential mixed cryoglobulinemia, Evans syndrome, fibromyalgia, fibrosing alveolitis, giant cell arteritis, giant cell myocarditis, glomerulonephritis, Goodpasture's syndrome, granulomatosis with polyangiitis, Graves' disease, Guillain-Barre syndrome, Hashimoto's thyroiditis, hemolytic anemia, Henoch-Schonlein purpura, herpes gestationis or pemphigoid gestationis, hypogammaglobulinemia, IgA nephropathy, IgG4-related sclerosing disease, immune thrombocytopenic purpura, inclusion body myositis, interstitial cystitis, juvenile arthritis, juvenile diabetes, juvenile myositis, Kawasaki disease, Lambert-Eaton syndrome, leukocytoclastic vasculitis, lichen planus, lichen sclerosis, ligneous conjunctivitis, linear IgA disease, lupus, Lyme disease chronic, Meniere's diseases, microscopic polyangiitis, mixed connective tissue disease, Mooren's ulcer, Mucha-Habermann disease, multiple sclerosis, myasthenia gravis, myositis, narcolepsy, neuromyelitis, optica, neutropenia, ocular cicatricial pemphigoid, optic neuritis, palindromic rheumatism, PANDAS, paraneoplastic cerebellar degeneration, paroxysmal nocturnal hemoglobinuria, Parry Romberg syndrome, pars planitis, Parsonage-Turner syndrome, pemphigus, peripheral neuropathy, perivenous encephalomyelitis, pernicious anemia, POEMS syndrome, polyarteritis nodosa, polyglandular syndromes, polymyalgia rheumatica, polymyositis, post-myocardial infarction syndrome, post-pericardiotomy syndrome, primary biliary cirrhosis, primary sclerosing cholangitis, progesterone dermatitis, psoriasis, psoriatic arthritis, pure red cell aplasia, pyoderma gangrenosum, Raynaud's phenomenon, reactive arthritis, reflex sympathetic dystrophy, relapsing polychondritis, restless legs syndrome, retroperitoneal fibrosis, rheumatic fever, rheumatoid arthritis, sarcoidosis, Schmidt syndrome, scleritis, scleroderma, Sjogren's syndrome, sperm and testicular autoimmunity, stiff person syndrome, subacute bacterial endo-

carditis, Susac's syndrome, sympathetic ophthalmia, Takayasu's arteritis, temporal arteritis, thrombocytopenic purpura, Tolosa-Hunt syndrome, transverse myelitis, type I diabetes, ulcerative colitis, undifferentiated connective tissue disease, uveitis, vasculitis, vitiligo, and Wegener's granulomatosis.

An IL-7R $\alpha\gamma$ c ligand or IL-7R $\alpha\gamma$ c IgG-Fc fusion protein provided by the present disclosure or a pharmaceutical composition thereof can be used to treat autoimmune disorders such as, for example, lupus, graft-versus-host disease, hepatitis C-induced vasculitis, Type I diabetes, multiple sclerosis, spontaneous loss of pregnancy, atopic diseases, and inflammatory bowel disease.

An IL-7R $\alpha\gamma$ c ligand or IL-7R $\alpha\gamma$ c IgG-Fc fusion protein provided by the present disclosure can be administered with one or more additional therapeutic agents for treating an autoimmune disease. For example, an IL-7R $\alpha\gamma$ c ligand or IL-7R $\alpha\gamma$ c IgG-Fc fusion protein or a pharmaceutical composition thereof can be administered in conjunction with one or more immunosuppressants including, for example, corticosteroids such as prednisone, budesonide, and prednisolone; Janus kinase inhibitors such as tofacitinib; calcineurin inhibitors such as cyclosporine and tacrolimus; mTOR inhibitors such as sirolimus and everolimus; IMDH inhibitors such as azathioprine, leflunomide, and mycophenolate; biologics such as abatacept, adalimumab, anakinra, certolizumab, etanercept, golimumab, infliximab, ixekizumab, natalizumab, rituximab, secukinumab, tocilizumab, ustekinumab, and vedolizumab; and monoclonal antibodies such as basiliximab and daclizumab.

An IL-7R $\alpha\gamma$ c ligand or IL-7R $\alpha\gamma$ c IgG-Fc fusion protein provided by the present disclosure or a pharmaceutical composition thereof can be administered to a patient to treat a disease associated with the activation, proliferation, metabolism, and/or differentiation of T-cells.

An IL-7R $\alpha\gamma$ c ligand or IL-7R $\alpha\gamma$ c IgG-Fc fusion protein provided by the present disclosure, or a pharmaceutical composition thereof can be administered to a patient to treat an infectious disease such as a viral disease.

Examples of infectious diseases include *Acinetobacter* infections, actinomycosis, African sleeping sickness (African trypanosomiasis), AIDS (acquired immunodeficiency syndrome), amoebiasis, anaplasmosis, angiostrongyliasis, anisakiasis, anthrax, *Arcanobacterium haemolyticum* infection, Argentine hemorrhagic fever, ascariasis, aspergillosis, astrovirus infection, babesiosis, *Bacillus cereus* infection, bacterial meningitis, bacterial pneumonia, bacterial vaginosis, *Bacteroides* infection, balantidiasis, bartonellosis, *Baylisascaris* infection, Bejel, syphilis, yaws, BK virus infection, black piedra, blastocystosis, blastomycosis, Bolivian hemorrhagic fever, botulism (and Infant botulism), Brazilian hemorrhagic fever, brucellosis, bubonic plague, *Burkholderia* infection, buruli ulcer, calicivirus infection (Norovirus and Sapovirus), campylobacteriosis, candidiasis (Moniliasis; Thrush), capillariasis, carrion's disease, cat-scratch disease, cellulitis, Chagas disease (American trypanosomiasis), chancroid, chickenpox, chikungunya, chlamydia, *Chlamydomytila pneumoniae* infection (Taiwan acute respiratory agent or TWAR), cholera, chromoblastomycosis, *Chytridiomycosis*, clonorchiasis, *Clostridium difficile colitis*, coccidioidomycosis, Colorado tick fever (CTF), common cold (acute viral rhinopharyngitis), Acute coryza, Coronavirus disease 2019 (COVID-19), Creutzfeldt-Jakob disease (CJD), Crimean-Congo hemorrhagic fever (CCHF), cryptococcosis, cryptosporidiosis, cutaneous larva migrans (CLM), cyclosporiasis, cysticercosis, cytomegalovirus infection, Dengue fever, desmodemus infection, dientam-

oebiasis, diphtheria, diphyllbothriasis, dracunculiasis, Ebola hemorrhagic fever, echinococcosis, Ehrlichiosis, enterobiasis (pinworm infection), *Enterococcus* infection, enterovirus infection, epidemic typhus, Epstein-Barr virus infectious mononucleosis (Mono), erythema infectiosum (Fifth disease), fxtanthen subitum (Sixth disease), fasciolosis, fasciolopsiasis, fatal familial insomnia (FFI), filariasis, food poisoning by *Clostridium perfringens*, free-living amebic infection, *Fusobacterium* infection, gas gangrene (Clostridial myonecrosis), geotrichosis, Gerstmann-Sträussler-Scheinker syndrome (GSS), giardiasis, glanders, gnathostomiasis, gonorrhoea, granuloma inguinale (Donovanosis), Group A streptococcal infection, Group B streptococcal infection, *Haemophilus influenzae* infection, hand, foot and mouth disease (HFMD), Hantavirus Pulmonary Syndrome (HPS), Heartland virus disease, *Helicobacter pylori* infection, hemolytic-uremic syndrome (HUS), hemorrhagic fever with renal syndrome (HFRS), Hendra virus infection, Hepatitis A, Hepatitis B, Hepatitis C, Hepatitis D, Hepatitis E, Herpes simplex, histoplasmosis, hookworm infection, human bocavirus infection, human ewingii ehrlichiosis, human granulocytic anaplasmosis (HGA), human metapneumovirus infection, human monocytic ehrlichiosis, human papillomavirus (HPV) infection, human parainfluenza virus infection, hymenolepiasis, influenza (flu), isosporiasis, Kawasaki disease, keratitis, *Kingella kingae* infection, Kuru, Lassa fever, Legionellosis (Legionnaires' disease), leishmaniasis, leprosy, leptospirosis, listeriosis, Lyme disease (Lyme borreliosis), lymphatic filariasis (elephantiasis), lymphocytic choriomeningitis, malaria, Marburg hemorrhagic fever (MHF), measles, melioidosis (Whitmore's disease), meningitis, meningococcal disease, metagonimiasis, microsporidiosis, Middle East respiratory syndrome (MERS), molluscum contagiosum (MC), monkeypox, mumps, murine typhus (Endemic typhus), mycetoma, *Mycoplasma genitalium* infection, mycoplasma pneumonia, myiasis, neonatal conjunctivitis (Ophthalmia neonatorum), Nipah virus infection, nocardiosis, Norovirus (children and babies), onchocerciasis (River blindness), opisthorchiasis, paracoccidioidomycosis (South American blastomycosis), paragonimiasis, pasteurellosis, pediculosis capitis (Head lice), pediculosis corporis (Body lice), pediculosis pubis (pubic lice, crab lice), pelvic inflammatory disease (PID), pertussis (whooping cough), plague, pneumococcal infection, pneumocystis pneumonia (PCP), pneumonia, poliomyelitis, Pontiac fever, *Prevotella* infection, primary amoebic meningoencephalitis (PAM), progressive multifocal leukoencephalopathy, psittacosis, Q fever, rabies, relapsing fever, respiratory syncytial virus infection, rhinosporidiosis, rhinovirus infection, rickettsial infection, rickettsialpox, Rift Valley fever (RVF), Rocky Mountain spotted fever (RMSF), rotavirus infection, rubella, salmonellosis, SARS (severe acute respiratory syndrome), scabies, scarlet fever, schistosomiasis, sepsis, shigellosis (bacillary dysentery), shingles (Herpes zoster), smallpox (variola), sporotrichosis, staphylococcal food poisoning, staphylococcal infection, strongyloidiasis, subacute sclerosing panencephalitis, taeniasis, tetanus (lockjaw), tinea barbae (barber's itch), tinea capitis (ringworm of the scalp), tinea corporis (ringworm of the body), tinea cruris (Jock itch), tinea manuum (ringworm of the hand), tinea nigra, tinea pedis (athlete's foot), tinea unguium (onychomycosis), tinea versicolor (Pityriasis versicolor), toxocariasis (ocular larva migrans (OLM), toxocariasis (visceral larva migrans (VLM), toxoplasmosis, trachoma, trichinosis, trichomoniasis, trichuriasis (whipworm infection), tuberculosis, tularemia, typhoid fever, typhus fever, *Ureaplasma urealyticum*

infection, valley fever, Venezuelan equine encephalitis, Venezuelan hemorrhagic fever, vibrio parahaemolyticus enteritis, vibrio vulnificus infection, viral pneumonia, West Nile fever, white piedra (tinea blanca), yellow fever, *Yersinia pseudotuberculosis* infection, yersiniosis, zea spora, Zika fever, and zygomycosis.

Examples of viral diseases include respiratory viral diseases such as influenza, respiratory syncytial virus infection, adenovirus infection, parainfluenza virus infection, and severe acute respiratory syndrome; gastrointestinal viral diseases such as nonovirus infection, rotavirus infection, and astrovirus infection; exanthematous viral disease such as measles, rubella, chickenpox and shingles, roseola, smallpox, fifth disease, and chikungunya virus infection; hepatic viral diseases such as hepatitis A, B, C, D, and E; cutaneous viral diseases such as warts, oral herpes, viral herpes, and molluscum contagiosum; hemorrhagic diseases such as Ebola, Lassa fever, dengue fever, yellow fever, Marburg hemorrhagic fever, and Crimean-Congo hemorrhagic fever; neurological diseases such as polio, viral meningitis, viral encephalitis, and rabies.

An IL-7R $\alpha\gamma$ c ligand or IL-7R $\alpha\gamma$ c IgG-Fc fusion protein provided by the present disclosure, or a pharmaceutical composition thereof can be administered to a patient to treat an organ transplant.

An IL-7R $\alpha\gamma$ c ligand or IL-7R $\alpha\gamma$ c IgG-Fc fusion protein provided by the present disclosure, or a pharmaceutical composition thereof can be administered in conjunction with an agent known or believed to interfere with proliferation, to interfere with mitosis, to interfere with DNA replication, or to interfere with DNA repair.

An IL-7R $\alpha\gamma$ c ligand or IL-7R $\alpha\gamma$ c IgG-Fc fusion protein provided by the present disclosure, or a pharmaceutical composition thereof can be administered to a patient to treat an immune deficiency disease.

Examples of primary immune deficiency diseases include autoimmune lymphoproliferative syndrome, autoimmune polyglandular syndrome type 1, BENTA disease, caspase eight deficiency state, CARDS deficiency, chronic granulomatous disease, common variable immunodeficiency, congenital neutropenia syndromes, CTLA4 deficiency, DOCK8 deficiency, GATA2 deficiency, glycosylation disorders, hyper-immunoglobulin E syndromes, hyper-immunoglobulin M syndromes, interferon β , interleukin 12 and interleukin 23 deficiency, leukocyte adhesion deficiency, LRBA deficiency, PI2 kinase disease, PLCG2-associated antibody deficiency and immune dysregulation, severe combined immunodeficiency, STAT3 dominant-negative disease, STAT3 gain-of-function disease, warts, hypogammaglobulinemia, infections, and myelokathexis syndrome, Wiskott-Aldrich syndrome, X-linked agammaglobulinemia, X-linked lymphoproliferative disease, and XMEN disease.

Secondary immune deficiency disease occurs when the immune system is compromised due to environmental factors such as infection, chemotherapy, severe burns, or malnutrition. Examples of secondary immune deficiency diseases include newborn immunodeficiencies such as immature lymphoid organs, absent memory immunity, low maternal IgG levels, decreased neutrophil storage pool, decreased neutrophil function, and decreased natural killer cell activity; advanced age related immunodeficiencies such as decreased antigen-specific cellular immunity, T-cell oligoclonality, and restricted B-cell repertoire; malnutrition related immunodeficiencies such as decreased cellular immune response and weakened mucosal barriers; diabetes mellitus related immunodeficiencies such as decreased mitogen-induced lymphoproliferation, defective phagocytosis,

and decreased chemotaxis; chronic uremia related immunodeficiencies such as decreased cellular immune response, decreased generation of memory antibody responses, and decreased chemotaxis; genetic syndromes such as defective phagocytosis, defective chemotaxis, and variable defects of antigen-specific immune responses; and anti-inflammatory, immunomodulatory, and immuno-suppressive drug therapy related immune deficiencies such as lymphopenia, decreased cellular immune response and anergy, decreased proinflammatory cytokines, decreased phagocytosis, decreased chemotaxis, neutropenia, and weakened mucosal barriers; environmental conditions such as increased lymphocyte apoptosis, increased secretion of tolerogenic cytokines, cytopenia, decreased cellular immunity and anergy, and stress-induced nonspecific immune activation; and infectious diseases such as T-cell lymphopenia, decreased cellular immune response and anergy, and defective antigen-specific antibody responses.

An IL-7R $\alpha\gamma$ c ligand or IL-7R $\alpha\gamma$ c IgG-Fc fusion protein provided by the present disclosure, or a pharmaceutical composition thereof can be administered to a patient to increase the immune response in an immuno-compromised patient.

An IL-7R $\alpha\gamma$ c ligand or IL-7R $\alpha\gamma$ c IgG-Fc fusion protein provided by the present disclosure, or a pharmaceutical composition thereof can be administered to a patient to increase the immune response in an elderly patient.

An IL-7R $\alpha\gamma$ c ligand or IL-7R $\alpha\gamma$ c IgG-Fc fusion protein provided by the present disclosure can be used to treat, for example, an umbilical cord blood transplant, human immunodeficiency virus (HIV), idiopathic CD4⁺ T-lymphocytopenia, chronic hepatitis B virus infection, severe sepsis with septic shock, hepatitis C virus infection, cancer including breast cancer, lymphogenic metastatic breast cancer, colon cancer, and bladder cancer, kidney cancer, prostate cancer, sarcoma, glioblastoma, and melanoma, which can be a solid tumor or metastatic tumor, Coronavirus (COVID-19), human papillomavirus (HPV), peripheral blood stem cell transplant, and incurable non-hematologic malignancy.

An IL-7R $\alpha\gamma$ c ligand or IL-7R $\alpha\gamma$ c IgG-Fc fusion protein provided by the present disclosure provided by the present disclosure can be used to treat, for example, newly diagnosed high grade glioma treated with radiation and temozolomide, metastatic breast cancer, post-allogeneic stem cell transplant, and solid tumors where improved outcomes are associated with increased tumor-infiltrating lymphocyte density.

An IL-7R $\alpha\gamma$ c ligand or IL-7R $\alpha\gamma$ c IgG-Fc fusion protein provided by the present disclosure can be used as a pretreatment to chemotherapy with a known risk of neutropenic fever or as a pre-treatment prior to apheresis in patients being administered CAR-T therapy.

An IL-7R $\alpha\gamma$ c ligand or IL-7R $\alpha\gamma$ c IgG-Fc fusion protein provided by the present disclosure can be used, either alone or in combination, to treat diseases including acute myeloid leukemia, B-cell lymphoma, chronic myelogenous leukemia, depression, gingivitis recession, hepatitis C, HIV infections, human papillomavirus, idiopathic CD4 lymphopenia, immunodeficiency secondary to organ transplantation, lipodystrophy, Kaposi sarcoma lymphoma, lymphopenia, mantle cell lymphoma, multiple sclerosis, myelodysplastic syndrome, non-Hodgkin lymphoma, recurrent adult diffuse large cell lymphoma, recurrent follicular lymphoma, rheumatoid arthritis, sepsis, and Type 2 diabetes.

An IL-7R $\alpha\gamma$ c ligand or IL-7R $\alpha\gamma$ c IgG-Fc fusion protein provided by the present disclosure can be used to treat newly diagnosed high grade glioma, metastatic breast cancer, post-

allogenic stem cell transplant engraftment, solid tumors, pre-treatment prior to initiation of dose dense chemotherapy with a known risk of neutropenic fever, or pre-treatment prior to apheresis in patient receiving CAR-T therapy.

An IL-7R $\alpha\gamma$ c ligand or IL-7R $\alpha\gamma$ c IgG-Fc fusion protein provided by the present disclosure can be used to treat severe sepsis with septic shock, peripheral blood stem cell transplant, prostate cancer, HIV, HCV, lymphopenic metastatic breast cancer, chronically infected HIV, solid tumors, metastatic melanoma, metastatic sarcoma, incurable nonhematologic malignancy, metastatic or recurrent tumors, HPV, locally advanced or metastatic solid tumors, or newly diagnosed glioblastoma.

An IL-7R $\alpha\gamma$ c ligand or IL-7R $\alpha\gamma$ c IgG-Fc fusion protein provided by the present disclosure can be used to treat lymphopenic patients with COVID-19 infection, urothelial carcinoma, non-tuberculous mycobacteria lung disease, cord blood transplant, COVID-19, refractory or relapsed triple negative breast cancer, Kaposi sarcoma, squamous cell carcinoma, lymphopenia in progressive multifocal leukoencephalopathy (PML), Merkel cell carcinoma, cutaneous squamous cell carcinoma, vaccine response, high grade gliomas, or gastric or gastro-esophageal junction or esophageal adenocarcinoma.

An IL-7R $\alpha\gamma$ c ligand or IL-7R $\alpha\gamma$ c IgG-Fc fusion protein provided by the present disclosure and pharmaceutical compositions of any of the foregoing can be administered to a patient together with another compound for treating an inflammatory disease, an autoimmune disease, an immunodeficiency disease, or a viral disease in a patient. The at least one other therapeutic agent can be an IL-7R $\alpha\gamma$ c ligand or IL-7R $\alpha\gamma$ c IgG-Fc fusion protein provided by the present disclosure. An IL-7R $\alpha\gamma$ c ligand or IL-7R $\alpha\gamma$ c IgG-Fc fusion protein and the at least one other therapeutic agent can act additively or synergistically. The at least one additional therapeutic agent can be included in the same pharmaceutical composition or vehicle comprising the IL-7R $\alpha\gamma$ c ligand or IL-7R $\alpha\gamma$ c IgG-Fc fusion protein or can be in a separate pharmaceutical composition or vehicle. Accordingly, methods provided by the present disclosure further include, in addition to administering an IL-7R $\alpha\gamma$ c ligand or IL-7R $\alpha\gamma$ c IgG-Fc fusion protein, administering one or more therapeutic agents effective for treating an inflammatory disease or an autoimmune disease or a different disease, disorder or condition than an inflammatory disease or an autoimmune disease. Methods provided by the present disclosure include administration of an IL-7R $\alpha\gamma$ c ligand or IL-7R $\alpha\gamma$ c IgG-Fc fusion protein and one or more other therapeutic agents provided that the combined administration does not inhibit the therapeutic efficacy of an IL-7R $\alpha\gamma$ c ligand or IL-7R $\alpha\gamma$ c IgG-Fc fusion protein and/or does not produce adverse combination effects.

An IL-7R $\alpha\gamma$ c ligand or IL-7R $\alpha\gamma$ c IgG-Fc fusion protein provided by the present disclosure can be used in combination with at least one other therapeutic agent. An IL-7R $\alpha\gamma$ c ligand or IL-7R $\alpha\gamma$ c IgG-Fc fusion protein can be administered to a patient together with another compound for treating cancer in the patient. The at least one other therapeutic agent can be a second, different IL-7R $\alpha\gamma$ c ligand or IL-7R $\alpha\gamma$ c IgG-Fc fusion protein. An IL-7R $\alpha\gamma$ c ligand or IL-7R $\alpha\gamma$ c IgG-Fc fusion protein and the at least one other therapeutic agent can act additively or, and in certain embodiments, synergistically with another IL-7R $\alpha\gamma$ c ligand or IL-7R $\alpha\gamma$ c IgG-Fc. The at least one additional therapeutic agent can be included in the same pharmaceutical composition or vehicle comprising the IL-7R $\alpha\gamma$ c ligand or IL-7R $\alpha\gamma$ c IgG-Fc fusion protein or can be in a separate

pharmaceutical composition or vehicle. Accordingly, methods provided by the present disclosure further include, in addition to administering an IL-7R $\alpha\gamma$ c ligand or IL-7R $\alpha\gamma$ c IgG-Fc fusion protein, administering one or more therapeutic agents effective for treating cancer or a different disease, disorder or condition than cancer. Methods provided by the present disclosure include administration of an IL-7R $\alpha\gamma$ c ligand or IL-7R $\alpha\gamma$ c IgG-Fc fusion protein and one or more other therapeutic agents provided that the combined administration does not inhibit the therapeutic efficacy of an IL-7R $\alpha\gamma$ c ligand or IL-7R $\alpha\gamma$ c IgG-Fc fusion protein and/or does not produce adverse combination effects.

A pharmaceutical composition comprising an IL-7R $\alpha\gamma$ c ligand or IL-7R $\alpha\gamma$ c IgG-Fc fusion protein can be administered concurrently with the administration of another therapeutic agent, which can be part of the same pharmaceutical composition as, or in a different pharmaceutical composition than that comprising an IL-7R $\alpha\gamma$ c ligand or IL-7R $\alpha\gamma$ c IgG-Fc fusion protein. An IL-7R $\alpha\gamma$ c ligand or IL-7R $\alpha\gamma$ c IgG-Fc fusion protein can be administered prior or after administration of another therapeutic agent. In certain combination therapies, the combination therapy can comprise alternating between administering an IL-7R $\alpha\gamma$ c ligand or IL-7R $\alpha\gamma$ c IgG-Fc fusion protein and a composition comprising another therapeutic agent, e.g., to minimize adverse drug effects associated with a particular drug. When an IL-7R $\alpha\gamma$ c ligand or IL-7R $\alpha\gamma$ c IgG-Fc fusion protein is administered concurrently with another therapeutic agent that potentially can produce an adverse drug effect including, for example, toxicity, the other therapeutic agent can be administered at a dose that falls below the threshold at which the adverse drug reaction is elicited.

A pharmaceutical composition comprising an IL-7R $\alpha\gamma$ c ligand or IL-7R $\alpha\gamma$ c IgG-Fc fusion protein provided by the present disclosure can be administered with one or more substances, for example, to enhance, modulate and/or control release, bioavailability, therapeutic efficacy, therapeutic potency, and/or stability, of the IL-7R $\alpha\gamma$ c ligand or IL-7R $\alpha\gamma$ c IgG-Fc fusion protein. For example, a pharmaceutical composition comprising an IL-7R $\alpha\gamma$ c ligand or IL-7R $\alpha\gamma$ c IgG-Fc fusion protein can be co-administered with an active agent having pharmacological effects that enhance the therapeutic efficacy of the IL-7R $\alpha\gamma$ c ligand or IL-7R $\alpha\gamma$ c IgG-Fc fusion protein.

An IL-7R $\alpha\gamma$ c ligand or IL-7R $\alpha\gamma$ c IgG-Fc fusion protein, or a pharmaceutical composition thereof can be administered in conjunction with an agent known or believed to be effective in treating a disease such as cancer, an autoimmune disease, an inflammatory disease in a patient, an immunodeficiency disease, or a viral disease in a patient, such as the same disease being treated with the IL-7R $\alpha\gamma$ c ligand or IL-7R $\alpha\gamma$ c IgG-Fc fusion protein.

Pharmaceutical compositions comprising an IL-7R $\alpha\gamma$ c ligand or IL-7R $\alpha\gamma$ c IgG-Fc fusion protein be administered concurrently with the administration of another therapeutic agent, which can be part of the same pharmaceutical composition as, or in a different pharmaceutical composition than that comprising an IL-7R $\alpha\gamma$ c ligand or IL-7R $\alpha\gamma$ c IgG-Fc fusion protein. An IL-7R $\alpha\gamma$ c ligand or IL-7R $\alpha\gamma$ c IgG-Fc fusion protein can be administered prior or subsequent to administration of another therapeutic agent. In combination therapy, the combination therapy can comprise alternating between administering an IL-7R $\alpha\gamma$ c ligand or IL-7R $\alpha\gamma$ c IgG-Fc fusion protein and a composition comprising another therapeutic agent, e.g., to minimize adverse drug effects associated with a particular drug. When an IL-7R $\alpha\gamma$ c ligand or IL-7R $\alpha\gamma$ c IgG-Fc fusion protein is

administered concurrently with another therapeutic agent that potentially can produce an adverse drug effect including, for example, toxicity, the other therapeutic agent can be administered at a dose that falls below the threshold at which the adverse drug reaction is elicited.

An IL-7R $\alpha\gamma$ ligand or IL-7R $\alpha\gamma$ IgG-Fc fusion protein, or a pharmaceutical composition thereof can be administered in conjunction with an agent known or believed to interfere with cell proliferation.

An IL-7R $\alpha\gamma$ ligand or IL-7R $\alpha\gamma$ IgG-Fc fusion protein, or a pharmaceutical composition thereof can be administered in conjunction with an agent known or believed to interfere with cellular metabolism, to be an anti-metabolite, to interfere with RNA transcription, to interfere with RNA translation, to interfere with cellular protein synthesis, to interfere with synthesis of precursors for DNA synthesis and replication, to interfere with purine synthesis, to interfere with nucleoside synthesis, to interact with mTOR, to be an mTOR inhibitor, to interfere with cell cycle checkpoints.

An IL-7R $\alpha\gamma$ ligand or IL-7R $\alpha\gamma$ IgG-Fc fusion protein or a pharmaceutical composition thereof can be administered in conjunction with a checkpoint inhibitor including a CTLA-4 inhibitor such as ipilimumab, a PD-1 inhibitor such as pembrolizumab and nivolumab, and/or a PD-L1 inhibitor such as atezolizumab, avelumab, and durvalumab. An IL-7R $\alpha\gamma$ ligand or IL-7R $\alpha\gamma$ IgG-Fc fusion protein or a pharmaceutical composition thereof can be administered in conjunction with an immunomodulator such as CD137/4-1BB, CD27, GIYR, and/or OC40.

An IL-7R $\alpha\gamma$ ligand or IL-7R $\alpha\gamma$ IgG-Fc fusion protein or a pharmaceutical composition thereof can be administered in conjunction with an agent known or believed to be cytotoxic, to cause DNA damage, to cause cell cycle arrest, or to cause mitotic catastrophe.

An IL-7R $\alpha\gamma$ ligand or IL-7R $\alpha\gamma$ IgG-Fc fusion protein or a pharmaceutical composition thereof can be administered in conjunction with an agent known or believed to modulate glutathione concentration, to modulate glutathione concentration within cells, to decrease glutathione concentration within cells, to reduce glutathione uptake into cells, to reduce glutathione synthesis, or to reduce glutathione synthesis within cells.

An IL-7R $\alpha\gamma$ ligand or IL-7R $\alpha\gamma$ IgG-Fc fusion protein provided by the present disclosure, or a pharmaceutical composition thereof can be administered in conjunction with an agent known or believed to interfere with neovascularization, to reduce neovascularization, or to promote neovascularization.

An IL-7R $\alpha\gamma$ ligand or IL-7R $\alpha\gamma$ IgG-Fc fusion protein provided by the present disclosure, or a pharmaceutical composition thereof can be administered in conjunction with an agent known or believed to interfere with hormone homeostasis, to interfere with hormone synthesis, to interfere with hormone receptor binding, or to interfere with hormone signal transduction.

An IL-7R $\alpha\gamma$ ligand or IL-7R $\alpha\gamma$ IgG-Fc fusion protein provided by the present disclosure, or a pharmaceutical composition thereof can be administered in conjunction with an agent known or believed to interfere with growth factor homeostasis, to interfere with growth factor receptor expression, to interfere with growth factor binding to growth factor receptors, to interfere with growth factor receptor signal transduction, to interfere with the Hedgehog (Hh) signaling, to inhibit the Hedgehog pathway signaling, to inhibit ALK (anaplastic lymphoma kinase) pathway signaling, or to inhibit the non-homologous end joining (NHEJ) pathway.

An IL-7R $\alpha\gamma$ ligand or IL-7R $\alpha\gamma$ IgG-Fc fusion protein provided by the present disclosure, or a pharmaceutical composition thereof can be administered in conjunction with one or more agents known or believed to be a VEGFR (vascular endothelial growth factor receptor) inhibitor, a RTK (receptor tyrosine kinase) inhibitor, a sodium channel current blocker, aFAK (focal adhesion kinase) inhibitor, a GLI (glioma-associated oncogene) inhibitor, a GLI1 inhibitor, a GLI2 inhibitor, a GLI3 inhibitor, a MAPK (mitogen-activated protein kinase) inhibitor, a MAPK/ERK pathway (also known as Ras-Raf-MEK-ERK pathways) inhibitor, a MEK1 inhibitor, a MEK2 inhibitor, a MEK5 inhibitor, a MEK5/ERK5 inhibitor, aRTA (renal tubular acidosis) inhibitor, a ALK (anaplastic lymphoma kinase) inhibitor, Aa LK kinase inhibitor, a nuclear translocation inhibitor, a PORCN (porcupine) inhibitor, a 5-ARI (5 α -reductase inhibitor), topoisomerase inhibitor, a Ras (rat sarcoma) inhibitor, a K-ras inhibitor, a CERK (ceramide kinase) inhibitor, a PKB (protein kinase B, also known as AKT) inhibitor, a AKT1 inhibitor, EZH2 (enhancer of zeste homolog 2) inhibitor, a BET (bromodomain and extraterminal domain motif) inhibitor, a SYK (spleen tyrosine kinase) inhibitor, JAK (janus kinase) inhibitors, a SYK/JAK inhibitor, a IDO (indoleamine-pyrrole 2,3-dioxygenase) inhibitor, a IDO1 inhibitor, a RXR (retinoic X receptors) activating agent, a selective RXR activating agent, a p-glycoprotein inhibitor, a ERK inhibitor, a PI3K (phosphatidylinositol-4,5-bisphosphate 3-kinase) inhibitor, a BRD (bromodomain-containing protein) inhibitor, a BRD2 inhibitor, a BRD3 inhibitor, a BRD4 inhibitor, a BRDT (bromodomain testis-specific protein) inhibitor, a reverse transcriptase inhibitor, a NRT (nucleoside analog reverse-transcriptase) inhibitor, a PIM (proviral integrations of moloney virus) inhibitor, a EGFR (epidermal growth factor receptor) inhibitor, a photosensitizer, a radiosensitizer, a ROS (proto-oncogene, receptor tyrosine kinase) inhibitor, a ROS1 (proto-oncogene 1) inhibitor, a CK (casein kinase) inhibitor, a CK2 inhibitor, a Bcr-Abl (breakpoint cluster region-Abelson proto-oncogene) tyrosine-kinase inhibitor such as dasatinib, a microtubule stabilizing agent, a microtubule depolymerization/dissassembly inhibitor, a DNA intercalator, an androgen receptor antagonist, a chemoprotective agents, a HDAC (histone deacetylase) inhibitor, a DPP (dipeptidyl peptidase) inhibitor, a DPP-4 inhibitor, BTK (Bruton's tyrosine kinase) inhibitor, a kinase inhibitor such as imatinib, a tyrosine kinase inhibitor such as nilotinib, a ARP (poly (ADP-ribose) polymerase) inhibitor, a CDK (cyclin-dependent kinase) inhibitor, a CDK4 inhibitor, a CDK6 inhibitor, a CDK4/6 inhibitor, a HIF1 α (hypoxia-inducible factor 1- α) inhibitor, a DNA ligase inhibitor, a DNA ligase IV inhibitor, a NHEJ (non-homologous end joining) inhibitor, a DNA ligase IV, a NHEJ inhibitor and a RAF inhibitor, a TKI and a RAF inhibitor, a TKI and RAF inhibitor such as sorafenib, a PDT (photodynamic therapy) sensitizer, an ATR (ataxia telangiectasia- and Rad3-related protein kinase) inhibitor, or a combination of any of the foregoing.

An IL-7R $\alpha\gamma$ ligand or IL-7R $\alpha\gamma$ IgG-Fc fusion protein provided by the present disclosure, or a pharmaceutical composition thereof can be administered in conjunction with one or more chemotherapeutic agents, such as, for example, a VEGFR inhibitor such as fruquintinib, motesanib/AMG-706, vatalanib; a RTK inhibitor such as ponatinib; a sodium channel blocker such as GS967; a FAK inhibitor such as TAE226; a GLI1 and GLI2 inhibitor such as GANT61, a MEK inhibitor such as binimetinib; a RTA inhibitor such as linifanib; an ALK inhibitor such as brigistinib; bromopyruvic acid; a DNA alkylating agent such as thiotepea; a nuclear

translocation factor such as JSH-23; a PORCn inhibitor such as Wnt-C59; a 5 α -reductase inhibitor such as dutasteride; a topoisomerase inhibitor such as carubicin; a RAS inhibitor such as K06065; a CerK inhibitor such as NVP-231; an AKT inhibitor such as uprosertib; a EZH2 inhibitor such as GSK-503; a BET bromodomain inhibitor such as OTX015; a MEK5/ERK5 inhibitor such as BIX02189; a Syl/JAK inhibitor such as cerdulatinib; an IDO1 inhibitor such as NLG919; a retinoic X receptor activating agent such as bexsrotene; a PGP inhibitor such as acotiamide or acoti-
 10 amide HCl; an Erk inhibitor such SCH772984; a PI3K inhibitor such as gedatolisib; a JAK inhibitor such as rux-olitinib; an AKT inhibitor such as afuresertib or afuresertib HCl; an ALK1 inhibitor such as ceritinib; an HDAC inhibitor such as abexinostat; a DPP inhibitor such as oamarglip-
 15 tin; an EGFR inhibitor such as gefitinib; an EZH2 inhibitor such as GSK126; a BTK inhibitor such as ibrutinib; a kinase inhibitor such as imatinin HCl; an IDO inhibitor such as INCB024360; a DNA crosslinker such as mitomycin C; a tyrosine kinase inhibitor such as nilotinib, a PARP inhibitor
 20 such as olaparib; a tubulin stabilization promoter such as paclitaxel; a CDK4/6 inhibitor such as palbociclib; a RTK inhibitor such as sunitinib; a PDT sensitizer such as tsl-sporfin; a p-glycoprotein inhibitor such as tariquidar; an ATR inhibitor such as VE-822; an HDAC inhibitor such as
 25 PCI-24781; a DPP inhibitor such as omarigliptin; an EGFR inhibitor such as gefinib; an EZH2 inhibitor such as GSK126; a BTK inhibitor such as ibrutinib; an IDO inhibitor such as INCB024360; or a combination of any of the foregoing.

For example, an IL-7R $\alpha\gamma\epsilon$ ligand or IL-7R $\alpha\gamma\epsilon$ IgG-Fc fusion protein provided by the present disclosure, or a pharmaceutical composition thereof can be administered in
 conjunction with another chemotherapeutic agent, such as, for example, N-acetyl cysteine (NAC), adriamycin,
 35 alemtuzumab, amifostine, arsenic trioxide, ascorbic acid, bendamustine, bevacizumab, bortezomib, busulfan, buthio-
 nine sulfoxime, carfilzomib, carmustine, clofarabine, cyclophosphamide, cyclosporine, cytarabine, dasatinib, datino-
 mycin, defibrotide, dexamethasone, docetaxel, doxorubicin, etoposide, filgrastim, floxuridine, fludarabine, gemcitabine,
 40 interferon alpha, ipilimumab, lenalidomide, leucovorin, melphalan, mycophenolate mofetil, paclitaxel, palifermin, panobinostat, pegfilgrastim, prednisolone, prednisone, revlimid, rituximab, sirolimus, sodium 2-mercaptoethane
 sulfonate (MESNA), sodium thiosulfate, tacrolimus, temo-
 zolomide, thalidomide, thioguanine, thiotepa, topotecan, velcade, or a combination of any of the foregoing.

An IL-7R $\alpha\gamma\epsilon$ ligand or IL-7R $\alpha\gamma\epsilon$ IgG-Fc fusion protein provided by the present disclosure, or a pharmaceutical
 50 compositions thereof can be used in combination therapy with other chemotherapeutic agents including one or more antimetabolites such as folic acid analogs; pyrimidine analogs such as fluorouracil, floxuridine, and cytosine arabino-
 55 side; purine analogs such as mercaptopurine, thioguanine, and pentostatin; natural products such as vinblastine, vincristine, etoposide, tertiposide, dactinomycin, daunoru-
 bicin, doxorubicin, bleomycin, mithamycin, mitomycin C, L-asparaginase, and interferon alpha; platinum coordination
 60 complexes such as cis-platinum, and carboplatin; mitoxan-
 trone; hydroxyurea; procarbazine; hormones and antagonists such as prednisone, hydroxyprogesterone caproate, medroxyprogesterone acetate, megestrol acetate, diethylstil-
 bestrol, ethinyl estradiol, tamoxifen, testosterone propi-
 onate, fluoxymesterone, flutamide, and leuprolide, anti-an-
 65 ti-angiogenesis agents or inhibitors such as angiostatin, retinoic acids, paclitaxel, estradiol derivatives, and thiazolopyrimi-

dine derivatives; apoptosis prevention agents; triptolide; colchicine; luliconazole; and radiation therapy.

An IL-7R $\alpha\gamma\epsilon$ ligand or IL-7R $\alpha\gamma\epsilon$ IgG-Fc fusion protein or a pharmaceutical composition thereof can be co-admin-
 5 istered with a compound that inhibits DNA repair such as, for example, O6-benzylguanine (O6-BG).

An IL-7R $\alpha\gamma\epsilon$ ligand or IL-7R $\alpha\gamma\epsilon$ IgG-Fc fusion protein provided by the present disclosure or a pharmaceutical
 composition thereof can be administered in conjunction with one or more chemotherapeutic agents, such as, for example,
 10 abarelix, abiraterone, abiraterone acetate, n-acetyl cysteine, aclarubicin hydrochloride, adriamycin, adenine, afatinib, afatinib dimaleate, alemtuzumab, alendronate sodium, alit-
 retinoin, allopurinol sodium, altretamine, amifostine, aminoglutethimide, aminolevulinic acid, amrubicin, amsacrine,
 anastrozole, angiostatin, apremilast, apreptant, arsenic tri-
 15 oxide, ascorbic acid, 1-asparaginase, azacitidine, azathio-
 prine sodium, bazedoxifene (serm), belinostat, bendamustine hcl, O6-benzylguanine, bevacizumab, bexarotene,
 bicalutamide, biricodar, bleomycin sulfate, bortezomib, bosutinib, brivudine, buserelin, busulfan, buthionine sulfoxime,
 cabazitaxel, cabozantinib, capecitabine, carboplatin, carboquone, carfilzomib, carmofur, carmustine, ceritinib,
 20 chlorambucil, cisplatin, cladribine, clodronate disodium, clofarabine, crizotinib, cyclophosphamide, cyclosporine, cytarabine, cytosine arabinoside, dabrafenib, dacarbazine, dactinomycin, dasatinib, datinomycin, daunorubicin, decit-
 abine, defibrotide, degarelix acetate, dexamethasone, dexrazoxane hydrochloride, diaziquone, diethyl stilbestrol,
 30 docetaxel, doxifluridine, doxorubicin hydrochloride, doxo-
 rubicin free base, dromostanolone propionate, dutasteride, eltrombopag, enzalutamide, epirubicin hydrochloride, eribu-
 lin mesylate, erlotinib hydrochloride, estramustine phos-
 35 phate sodium, ethinyl estradiol, etoposide phosphate, etopo-
 side, everolimus, exemestane, fentanyl, filgrastim, fingolimod, floxuridine, fludarabine phosphate, fluorouracil, fluoxymesterone, flutamide, formestane, formylmelphalan, fosaprepitant, fotemustine, fulvestrant, gefitinib, gemcit-
 abine hydrochloride, gemcitabine free base, glutathione, glyci-
 40 phosphoramidate, glyfosfin, goserelin acetate, gransi-
 etron hydrochloride, heptaplatin, hexyl 5-aminolevulinate, histrelin acetate, hydroxyprogesterone caproate,
 hydroxyurea, ibandronate sodium, ibrutinib, icotinib, idaru-
 bicin HCl, idelalisib, idoxuridine, ifosfamide, interferon
 45 alpha, imatinib mesylate, imiquimod, ingenol mebutate, ipilimumab, irinotecan hydrochloride, ixabepilone, lan-
 reotide acetate, lapatinib free base, lapatinib ditosylate, lasofoxifene, lenalidomide, letrozole, leucovorin calcium,
 leuprolide acetate, levamisole hydrochloride, levoleuco-
 50 vorin calcium, iobenguane, lobaplatin, lomustine, maropi-
 tant, masoprocol, mechlorethamine hydrochloride, mege-
 strol acetate, medroxyprogesterone acetate, melphalan
 hydrochloride, mercaptopurine, mercaptoethane sulfonate
 55 sodium, methotrexate, methoxsalen, methyl aminolevuli-
 nate, methylene blue, methylisoindigotin, mifamurtide, miltefosine, miriplatin, mithamycin, mitobronitol, mitomy-
 cin C, mitotane, mitoxantrone hydrochloride, mycopheno-
 late mofetil, nabiximols, nafarelin, nandrolone, nedaplatin,
 60 nelarabine, netupitant, nilotinib, nilutamide, nimustine, nin-
 tedanib, nocodazole, octreotide, olaparib, omacetaxine
 mepesuccinate, ondansetron hydrochloride, oxaliplatin,
 paclitaxel, palbociclib, palifermin, palonosetron hydrochlo-
 ride, pamidronate disodium, panobinostat, pasireotide,
 pazopanib hydrochloride, pegfilgrastim, pemeterid diso-
 65 dium, pentostatin, peplomycin, pipobroman, pirarubicin,
 plerixafor, plicamycin, pomalidomide, ponatinib, porfimer
 sodium, porfiromycin, pralatrexate, prednimustine, pred-

nisolone, prednisone, procarbazine hydrochloride, quina-
golide hydrochloride, raloxifene, raltitrexed, radotinib, rani-
mustine, retinoic acids, revlimide, rituxinab, romidepsin,
ruxolitinib, ruxolitinib phosphate, semustine, sirolimus,
sodium thiosulfate, sorafenib free base, sorafenib tosylate,
streptozocin, sufentanil, sunitinib, tacrolimus, talaporfin
sodium, tamibarotene, tamoxifen citrate, tapentadol,
temporfin, temozolomide, temsirolimus, teniposide, teri-
flunomide, tertiposide, testolactone, testosterone propionate,
thalidomide, thioguanine, thiotepa, thymalfasin, toceranib
phosphate, topotecan hydrochloride, toremifene citrate, tra-
bectedin, trametinib, tretinoin, trilostane, triptorelin, tropi-
setron, uramustine, valrubicin, vandetanib, vedotin, vemur-
afenib, verteporfin, vinblastine, vincristine sulfate,
vincristine free base, vindesine, vinorelbine tartrate, vor-
inostat, and zoledronic acid.

An IL-7R $\alpha\gamma$ ligand or IL-7R $\alpha\gamma$ IgG-Fc fusion protein
provided by the present disclosure, or a pharmaceutical
composition thereof can be administered in conjunction with
one or more chemotherapeutic agents such as, for example,
abemaciclib, abiraterone acetate, ABVD, ABVE, ABVE-
PC, AC, acalabrutinib, AC-T, ADE, ado-trastuzumab
emtansine, afatinib dimaleate, aldesleukin, alectinib,
alemtuzumab, alpelisib, amifostine, aminolevulinic acid
hydrochloride, anastrozole, apalutamide, aprepitant, arsenic
trioxide, asparaginase *Erwinia chrysanthemi*, atezolizumab,
avelumab, axicabtagene ciloleucel, axitinib, azacitidine,
BEACOPP, belinostat, bendamustine hydrochloride, BEP,
bevacizumab, bexarotene, bicalutamide, binimetinib, bleo-
mycin sulfate, blinatumomab, bortezomib, bosutinib, bren-
tuximab vedotin, brigatinib, BuMel, busulfan, cabazitaxel,
cabozantinib-s-malate, CAF, calaspargase pegol-mknl,
capecitabine, caplacizumab-yhdp, CAPDX, carboplatin,
carboplatin-taxol, carfilzomib, carmustine, carmustine
implant, CEM, cemiplimab-rwlc, ceritinib, cetuximab, CEV,
chlorambucil, chlorambucil-prednisone, CHOP, cisplatin,
cladribine, clofarabine, CMF, cobimetinib, copanlisib
hydrochloride, COPDAC, COPP, COPP-ABV, crizotinib,
CVP, cyclophosphamide, cytarabine, cytarabine liposome,
dabrafenib mesylate, dacarbazine, dacomitinib, dactinomycin,
daratumumab, darbepoetin α , dasatinib, daunorubicin
hydrochloride, daunorubicin hydrochloride and cytarabine
liposome, decitabine, defibrotide sodium, degarelix, denile-
ukin diftitox, denosumab, dexamethasone, dexrazoxane
hydrochloride, dinutuximab, docetaxel, doxorubicin hydro-
chloride, doxorubicin hydrochloride liposome, durvalumab,
duvelisib, elotuzumab, eltrombopag olamine, emapalumab-
lzsg, enasidenib mesylate, encorafenib, enzalutamide, epi-
rubicin hydrochloride, EPOCH, epoetin alfa, erdafitinib,
eribulin mesylate, erlotinib hydrochloride, etoposide, etopo-
side phosphate, everolimus, exemestane, fec, filgrastim,
fludarabine phosphate, fluorouracil injection, fluorouracil-
topical, flutamide, folfiri, folfiri-bevacizumab, folfiri-cetux-
imab, folfirinix, folfox, fostamatinib disodium, FU-LV, ful-
vestrant, gefitinib, gemcitabine hydrochloride, gemcitabine-
cisplatin, gemcitabine-oxaliplatin, gemtuzumab
ozogamicin, gilteritinib fumarate, glasdegib maleate, glu-
carpidase, goserelin acetate, granisetron, HPV bivalent vac-
cine, HPV bivalent vaccine, recombinant HPV nonavalent
vaccine, HPV nonavalent vaccine, recombinant, HPV qua-
drivalent vaccine, HPV uadrivalent vaccine recombinant,
hydroxyurea, hyper-CVAD, ibritumomab tiuxetan, ibritinib,
ICE, idarubicin hydrochloride, idelalisib, ifosfamide, ima-
tinib mesylate, imiquimod, inotuzumab ozogamicin, inter-
feron α -2b recombinant, iobenguane I¹³¹, ipilimumab, iri-
notecan hydrochloride, irinotecan hydrochloride liposome,
ivosidenib, ixabepilone, ixazomib citrate, JEB, lanreotide

acetate, lapatinib ditosylate, larotrectinib sulfate, lenalido-
mide, lenvatinib mesylate, letrozole, leucovorin calcium,
leuprolide acetate, lomustine, lorlatinib, lutetium Lu 177-
dotatate, mechlorethamine hydrochloride, megestrol acetate,
melphalan, melphalan hydrochloride, mercaptopurine,
mesna, methotrexate, methylalantrexone bromide, midostau-
rin, mitomycin c, mitoxantrone hydrochloride, mogamuli-
zumab-kpkc, moxetumomab pasudotox-tdfk, MVAC, neci-
tumumab, nelarabine, neratinib maleate, netupitant and
palonosetron hydrochloride, nilotinib, nilutamide, niraparib
tosylate monohydrate, nivolumab, obinutuzumab, OEPA,
ofatumumab, OFF, olaparib, olaratumab, omacetaxine
mepesuccinate, ondansetron hydrochloride, OPPIA, osimer-
tinib mesylate, oxaliplatin, paclitaxel, paclitaxel albumin-
stabilized nanoparticle formulation, PAD, palbociclib, pali-
fermin, palonosetron hydrochloride, palonosetron
hydrochloride and netupitant, pamidronate disodium, pani-
tumumab, panobinostat, pazopanib hydrochloride, PCV,
PEB, pegaspargase, pegfilgrastim, peginterferon α -2b, pem-
brolizumab, pemetrexed disodium, pertuzumab, plerixafor,
polatuzumab vedotin-piiq, pomalidomide, ponatinib hydro-
chloride, pralatrexate, prednisone, procarbazine hydrochlo-
ride, propranolol hydrochloride, radium 223 dichloride, ral-
oxifene hydrochloride, ramucirumab, rasburicase,
ravulizumab-cwvz, R-CHOP, R-CVP, recombinant HPV
bivalent vaccine, recombinant HPV nonavalent vaccine,
recombinant HPV quadrivalent vaccine, recombinant inter-
feron α -2b, regorafenib, R-EPOCH, ribociclib, R-ICE, rit-
uximab, rituximab and hyaluronidase human, rolapitant
hydrochloride, romidepsin, romiplostim, rucaparib camsy-
late, ruxolitinib phosphate, siltuximab, sipuleucel-t,
sonidegib, sorafenib tosylate, STANFORD V, sunitinib
malate, TAC, tagraxofusp-erzs, talazoparib tosylate, talc,
talimogene laherparepvec, tamoxifen citrate, temozolomide,
temsirolimus, thalidomide, thioguanine, thiotepa, tisagenle-
cleucel, tocilizumab, topotecan hydrochloride, toremifene,
TPF, trabectedin, trametinib, trastuzumab, trastuzumab and
hyaluronidase-oysk, trifluridine and tipiracil hydrochloride,
uridine triacetate, VAC, Valrubicin, VAMP, vandetanib,
VeIP, vemurafenib, venetoclax, vinblastine sulfate, vincris-
tine sulfate liposome, vinorelbine tartrate, vip, vismodegib,
vorinostat, XELIRI, XELOX, Ziv-aflibercept, zoledronic
acid, and combinations of any of the foregoing.

The efficacy of administering an IL-7R $\alpha\gamma$ ligand or
IL-7R $\alpha\gamma$ IgG-Fc fusion protein provided by the present
disclosure or a pharmaceutical composition thereof for treat-
ing cancer can be assessed using in vitro and animal studies
and in clinical trials.

The suitability of an IL-7R $\alpha\gamma$ ligand or IL-7R $\alpha\gamma$ IgG-
Fc fusion protein provided by the present disclosure or a
pharmaceutical composition thereof in treating cancer can
be determined by methods described in the art.

An IL-7R $\alpha\gamma$ ligand or IL-7R $\alpha\gamma$ IgG-Fc fusion protein
provided by the present disclosure, or a pharmaceutical
composition thereof can be used to treat a disease in com-
bination with an immune-oncology agent.

Examples of suitable immune-oncology agents include
anti-PD1, PDL1, CTLA4, TIGIT, LAG3, and combinations
of any of the foregoing.

Examples of suitable immune-oncology agents include
cytokine derivatives of IL-2, IL-15, IL-12, IL-18, and IL-21;
and interferons, and combinations of any of the foregoing.

Immune-oncology agents include immune checkpoint
inhibitors such as pembrolizumab, nivolumab, atezoli-
zumab, atezolizumab, durvalumab, avelumab, cemiplimab,
ipilimumab, toripalimab, sintilimab, camrelizumab, and
tislelizumab; T-cell transfer therapy such as tumor-infiltrat-

ing lymphocyte therapy and CAR T-cell therapy; monoclonal antibody therapy; cancer treatment vaccines, and immune system modulators such as interferons, interleukins, BCG, and immunomodulatory drugs such as thalidomide, lenalidomide, pomalidomide, and imiquimod.

Examples of CAR-T cell therapies include axicabtagene ciloleucel, brexucabtagene autoleucel, ciltacabtagene autoleucel, idecabtagene vicleucel, lisocabtagene maraleucel, and tisagenlecleucel.

Examples of interferons include interferon β -1a, peginterferon β -1a, interferon β -1b, interferon alfacon-1, interferon α -n3, and interferon γ -1b.

An IL-7R α γ c ligand or IL-7R α γ c IgG-Fc fusion protein provided by the present disclosure, or a pharmaceutical composition thereof can be used in combination with radiation therapy to treat cancer. Radiation therapy includes ionizing radiation such as X-rays, gamma-rays, and particle radiation beams. The radiation can be ionizing radiation such as a beam of protons, alpha particles, or beta particles. The radiation can be indirectly ionizing radiation such as electromagnetic waves and neutron beams. Radiation therapy includes external beam radiation therapy and internal radiation therapy such as brachytherapy.

Pharmaceutical compositions comprising an IL-7R α γ c ligand or IL-7R α γ c IgG-Fc fusion protein provided by the present disclosure can be administered with one or more substances to enhance, modulate and/or control release, bioavailability, therapeutic efficacy, therapeutic potency, and stability, of an IL-7R α γ c ligand or IL-7R α γ c IgG-Fc fusion protein. For example, to enhance the therapeutic efficacy of an IL-7R α γ c ligand or IL-7R α γ c IgG-Fc fusion protein, metabolite thereof, or a pharmaceutical composition of any of the foregoing can be co-administered with one or more active agents to increase the absorption or diffusion of the IL-7R α γ c ligand or IL-7R α γ c IgG-Fc fusion protein from the gastrointestinal tract to the systemic circulation, or to inhibit degradation of the IL-7R α γ c ligand or IL-7R α γ c IgG-Fc fusion protein in the blood of a subject. A pharmaceutical composition comprising an IL-7R α γ c ligand or IL-7R α γ c IgG-Fc fusion protein can be co-administered with an active agent having pharmacological effects that enhance the therapeutic efficacy of the IL-7R α γ c ligand or IL-7R α γ c IgG-Fc fusion protein.

The amount of an IL-7R α γ c ligand or IL-7R α γ c IgG-Fc fusion protein provided by the present disclosure, or pharmaceutical composition thereof that will be effective in the treatment of a cancer, an inflammatory disease, an autoimmune disease, or a viral disease can depend, at least in part, on the nature of the disease, and can be determined by standard clinical techniques known in the art. In addition, *in vitro* or *in vivo* assays can be employed to help identify optimal dosing ranges. Dosing regimens and dosing intervals can also be determined by methods known to those skilled in the art. The amount of an IL-7R α γ c ligand or IL-7R α γ c IgG-Fc fusion protein provided by the present disclosure administered can depend on, among other factors, the patient being treated, the weight of the patient, the severity of the disease, the route of administration, and the judgment of the prescribing physician.

For systemic administration, a therapeutically effective dose can be estimated initially from *in vitro* assays. Initial doses can also be estimated from *in vivo* data, e.g., animal models, using techniques that are known in the art. Such information can be used to more accurately determine useful doses in humans. One having ordinary skill in the art can optimize administration to humans based on animal data.

A dose of an IL-7R α γ c ligand or IL-7R α γ c IgG-Fc fusion protein provided by the present disclosure and appropriate dosing intervals can be selected to maintain a sustained therapeutically effective concentration of the IL-7R α γ c ligand or IL-7R α γ c IgG-Fc fusion protein provided by the present disclosure in the blood of a patient, and in certain embodiments, without exceeding a minimum adverse concentration.

A pharmaceutical composition comprising an IL-7R α γ c ligand or IL-7R α γ c IgG-Fc fusion protein provided by the present disclosure can be administered, for example, once per week, every 2 weeks, every 3 weeks, every 4 weeks, every 5 weeks, or every 6 weeks. Dosing can be provided alone or in combination with other drugs and can continue as required for effective treatment of the disease. Dosing can also be undertaken using continuous or semi-continuous administration over a duration. Dosing includes administering a pharmaceutical composition to a mammal, such as a human, in a fed or fasted state.

A pharmaceutical composition can be administered in a single dosage form or in multiple dosage forms or as a continuous or an accumulated dose over a duration. When multiple dosage forms are used the amount of an IL-7R α γ c ligand or IL-7R α γ c IgG-Fc fusion protein provided by the present disclosure contained within each of the multiple dosage forms can be the same or different.

Suitable daily dosage ranges for administration can range, for example, from about 2 μ g to about 200 mg of an IL-7R α γ c ligand or IL-7R α γ c IgG-Fc fusion protein provided by the present disclosure per kilogram body weight.

Suitable daily dosage ranges for administration can range, for example, from about 1 μ g to about 50 mg of an IL-7R α γ c ligand or IL-7R α γ c IgG-Fc fusion protein provided by the present disclosure per square meter (m^2) of body surface.

An IL-7R α γ c ligand or IL-7R α γ c IgG-Fc fusion protein provided by the present disclosure can be administered to treat cancer in a patient in an amount, for example, from 0.001 mg/day to 100 mg/day, or in any other appropriate daily dose. A dose can be, for example, from 0.01 μ g/kg body weight/week to 100 μ g/kg body weight/week or any other suitable dose.

A pharmaceutical composition comprising an IL-7R α γ c ligand or IL-7R α γ c IgG-Fc fusion protein provided by the present disclosure can be administered to treat cancer in a patient so as to provide a therapeutically effective concentration of an IL-7R α γ c ligand or IL-7R α γ c IgG-Fc fusion protein provided by the present disclosure in the blood or plasma of the patient. A therapeutically effective concentration of a compound of an IL-7R α γ c ligand or IL-7R α γ c IgG-Fc fusion protein provided by the present disclosure in the plasma of a patient can be, for example, from 0.01 μ g/L to 1,000 μ g/L, from 0.1 μ g/L to 500 μ g/L, from 1 μ g/L to 250 μ g/L, or from about 10 μ g/L to about 100 μ g/L. A therapeutically effective concentration of an IL-7R α γ c ligand or IL-7R α γ c IgG-Fc fusion protein provided by the present disclosure in the plasma of a patient can be, for example, at least 0.01 μ g/L, at least 0.1 μ g/L, at least 1 μ g/L, at least about 10 μ g/L, or at least 100 μ g/L. A therapeutically effective concentration of an IL-7R α γ c ligand or IL-7R α γ c IgG-Fc fusion protein in the plasma of a patient can be, for example, less than an amount that causes unacceptable adverse effects including adverse effects to homeostasis. A therapeutically effective concentration of an IL-7R α γ c ligand or IL-7R α γ c IgG-Fc fusion protein in the plasma of a patient can be an amount sufficient to restore and/or maintain homeostasis in the patient.

Pharmaceutical compositions comprising an IL-7R α γ c ligand or IL-7R α γ c IgG-Fc fusion protein can be administered to treat a disease in a patient so as to provide a therapeutically effective concentration of the IL-7R α γ c ligand or IL-7R α γ c IgG-Fc fusion protein in the blood or plasma of a patient for an extended period of time such as, for example, for at least 1 day, for at least 1 week, at least 2 weeks, at least 4 weeks, at least 5 weeks, or at least 6 weeks.

The amount of an IL-7R α γ c ligand or IL-7R α γ c IgG-Fc fusion protein administered can vary during a treatment regimen.

Pharmaceutical compositions provided by the present disclosure can further comprise one or more pharmaceutically active compounds in addition to an IL-7R α γ c ligand or IL-7R α γ c IgG-Fc fusion protein provided by the present disclosure. Such compounds can be provided, for example, to treat the cancer being treated with the IL-7R α γ c ligand or IL-7R α γ c IgG-Fc fusion protein or to treat a disease, disorder, or condition other than the cancer being treated with the IL-7R α γ c ligand or IL-7R α γ c IgG-Fc fusion protein, to treat a side-effect caused by administering the IL-7R α γ c ligand or IL-7R α γ c IgG-Fc fusion protein, to augment the efficacy of the IL-7R α γ c ligand or IL-7R α γ c IgG-Fc fusion protein, and/or to modulate the activity of the an IL-7R α γ c ligand or IL-7R α γ c IgG-Fc fusion protein.

IL-7R α γ c ligands and IL-7R α γ c IgG-Fc fusion proteins provided by the present disclosure can be useful in vitro as tools for understanding the biological role of IL-7, including the evaluation of the many factors thought to influence, and be influenced by, the production of IL-7 and the receptor binding process. The present compounds are also useful in the development of other compounds that bind to and activate IL-7R, because the present compounds provide useful information concerning the relationship between structure and activity that should facilitate such development.

The IL-7R α γ c ligands and IL-7R α γ c IgG-Fc fusion proteins are also useful as competitive binders in assays to screen for new IL-7 receptor agonists and antagonists. In such assays, an IL-7R α γ c ligand or IL-7R α γ c IgG-Fc fusion protein can be used without modification or can be modified in a variety of ways; for example, by labeling, such as covalently or non-covalently joining a moiety which directly or indirectly provides a detectable signal. In any of these assays, the materials thereto can be labeled either directly or indirectly. Possibilities for direct labeling include label groups such as: radiolabels such as ¹²⁵I, enzymes such as peroxidase and alkaline phosphatase, and fluorescent labels capable of monitoring the change in fluorescence intensity, wavelength shift, or fluorescence polarization. Possibilities for indirect labeling include biotinylation of one constituent followed by binding to avidin coupled to one of the above label groups. The compounds can also include spacers or linkers in cases where the compounds are to be attached to a solid support.

Based on the ability to bind to IL-7R, an IL-7R α γ c ligand or IL-7R α γ c IgG-Fc fusion protein provided by the present disclosure can be used as reagents for detecting IL-7R, for example, on living cells, fixed cells, in biological fluids, in tissue homogenates, in purified, and natural biological materials. For example, by labeling such peptides, one can identify cells expressing the IL-7R α and R γ c subunits. In addition, based on the ability to bind to IL-7R, the IL-7R α γ c ligand and IL-7R α γ c IgG-Fc fusion protein provided by the present disclosure can be used, for example, in situ staining, FACS (fluorescence-activated cell sorting), West-

ern Blotting, and ELISA. In addition, based on the ability to bind to IL-7R, the IL-7R α γ c ligand and IL-7R α γ c IgG-Fc fusion proteins provided by the present disclosure can be used in receptor purification, or in purifying cells expressing IL-7R on the cell surface (or inside permeabilized cells).

IL-7R α γ c ligands and IL-7R α γ c IgG-Fc fusion proteins provided by the present disclosure can also be utilized as commercial reagents for various medical research and diagnostic uses. Such uses include, for example, (1) use as a calibration standard for quantitating the activities of candidate IL-7 agonists in a variety of functional assays; (2) use to maintain the proliferation and growth of IL-7-dependent cell lines; (3) use in structural analysis of IL-7R through co-crystallization; (4) use to investigate the mechanism of IL-7 signal transduction/receptor activation; and (5) other research and diagnostic applications wherein the IL-7 receptor is implicated.

An IL-7R α γ c ligand or IL-7R α γ c IgG-Fc fusion protein includes diagnostic reagents. As a diagnostic agent, an IL-7R α γ c ligand or IL-7R α γ c IgG-Fc fusion protein can be used to detect and/or to measure cells expressing the IL-7R subunit. The compounds can be used to determine the level of IL-7R expression of a cell, of a population of cells, or of a tissue. The compounds can be used to assess the binding affinity to IL-7R in a cell or population of cells. The compounds can be used to determine a particular type of cell, for example, based on IL-7R expression levels.

The IL-7R α γ c ligands and IL-7R α γ c IgG-Fc fusion proteins can be useful for in vitro and in vivo diagnostics.

A diagnostic IL-7R α γ c ligand or IL-7R α γ c IgG-Fc fusion protein can comprise a detectable marker. The detectable marker can be cleavable or non-cleavable.

A detectable marker can comprise, for example, a radiolabel, a fluorescent label, and/or an enzymatic label.

A diagnostic IL-7R α γ c ligand or IL-7R α γ c IgG-Fc fusion protein can be used to measure cells expressing the IL-7R α subunit and/or the level of expression of cells expressing the IL-7R α subunit in a biological sample such as a sample of blood of a patient. Measurements can be made, for example, using flow cytometry. The number of cells expressing the IL-7R α subunit and/or the expression level of the IL-7R α subunit, when correlated with a disease in a patient or a pharmacologically significant parameter of the disease in a patient can be used to inform treatment of the disease. For example, if a level of expression of the IL-7R α subunit is above or below a therapeutically meaningful threshold for a particular disease, a compound comprising an IL-7R α ligand provided by the present disclosure can be administered to the patient to treat the disease.

An IL-7R α γ c ligand or IL-7R α γ c IgG-Fc fusion protein can be attached to a solid support. Based on the ability of the compounds to bind to IL-7R, the compounds can be used as reagents for detecting IL-7R, for example, on living cells, fixed cells, in biological fluids, in tissue homogenates, in purified, and natural in biological materials. In addition, based on the ability to bind to IL-7R and/or to an IL-7R subunit, the peptides provided by the present disclosure can be used, for example, in situ staining, FACS (fluorescence-activated cell sorting), Western Blotting, and ELISA. In addition, compounds provided by the present disclosure can be used in receptor purification, or to purify cells expressing IL-7R on the cell surface.

An IL-7R α γ c ligand or IL-7R α γ c IgG-Fc fusion protein provided by the present disclosure can be therapeutically useful when combined with certain vaccines, including cancer neo-antigen vaccines. Mutations in tumor DNA produces new protein sequences that are foreign to the body.

Vaccines can be designed to specifically activate a patient's immune system with respect to tumor-specific neo-antigens. When administered in combination with a neo-antigen vaccine and IL-7R $\alpha\gamma\epsilon$ ligand or IL-7R $\alpha\gamma\epsilon$ IgG-Fc fusion protein provided by the present disclosure can expand and proliferate neo-antigen-specific T-cells in the tumor microenvironment and thereby drive maximal expansion of vaccine-induced neo-antigen-specific T-cells for the treatment of cancer.

An IL-7R $\alpha\gamma\epsilon$ ligand or IL-7R $\alpha\gamma\epsilon$ IgG-Fc fusion protein provided by the present disclosure can be used as an adjuvant. An adjuvant refers to a compound that enhances the efficacy of a vaccine without directly participating in the protective immunity. For example, an IL-7R $\alpha\gamma\epsilon$ ligand or IL-7R $\alpha\gamma\epsilon$ IgG-Fc fusion protein provided by the present disclosure can be used in conjunction with a cancer vaccine or a viral vaccine.

Recent research suggests that IL-7 can serve as an effective vaccine adjuvant. For example, IL-7R α is expressed on the majority of resting, naive CD8+ T cells; IL-7 signaling recruits T cells specific for low-affinity antigens into the proliferative pool in lymphopenic hosts; and, as with other R $\gamma\epsilon$ cytokines, IL-7 prevents programmed cell death. Because IL-7 is important during the expansion and development of effector T-cells into memory T-cells, it is reasonable that IL-7 could be used to stimulate the development and expansion of effector T-cells during vaccination.

Administration of IL-7 has been shown therapeutic potential for augmenting the immune response and can enhance the effectiveness of vaccine-induced T cell responses.

For example, co-delivery of hu-IL-7 DNA augmented multigenic HCV DNA vaccine-induced T-cell responses in a non-human primate model.

In bacterial infections, therapeutic potential of IL-7 in the setting of sepsis mouse model was proven by increasing the number of recruited neutrophils.

Therapies involving administration of IL-7 showed enhanced virus-specific T-cell responses which led to viral clearance in a chronic lymphocytic choriomeningitis (LCMV) mouse infection model. Administration of recombinant IL-7 during the contraction phase of CD8+ T cell responses elicited in response to DNA vaccines increased the number of LCMV-specific memory T-cells.

In a murine model of influenza, A virus (IAV) it was demonstrated that a single intranasal pretreatment with Fc-fused IL-7 (IL-7-mFc), but not a native form of IL-7, protected mice from IAV-induced mortality for an extended period of time, even without preexisting IAV-specific immunity. IL-7-mFc treatment induced altered immune environments in the lung, with prolonged occupancy of lung-retentive effector/memory phenotype T (TRM-like) cells, which play an essential role in protection from IAVs by limiting viral replication and immunopathology, while helping IAV-specific cytotoxic T lymphocytes (CTLs) to propagate.

In another study, in which a recombinant RABV (rRABV) expressing mouse IL-7 was administered to mice, it was found that overexpressing IL-7 improved the production of long-lasting primary and secondary antibody responses to RABV infection.

It has been reported that recombinant IL-7 protein enhances the survival of Mycobacterium tuberculosis-infected mice by the activation of antigen-specific effector CD8+ T cells.

Furthermore, IL-7-expressing plasmids can enhance vaccine-induced CTL and/or Th2-type immune responses in mice injected with HSV-2 gD DNA vaccine.

In another study a DNA vaccine encoding the VP1 capsid protein of foot and mouth disease virus was co-delivered to mice with an IL-6 expressing plasmid as an initial adjuvant and boosted with an IL-7 expressing plasmid as a secondary adjuvant. Mice immunized with pVAX-IL-6 and boosted with pVAX-IL-7 produced the highest expression of CD44^{high} CD62L^{low} in activated CD4+ T cells.

An IL-7R $\alpha\gamma\epsilon$ ligand or IL-7R $\alpha\gamma\epsilon$ IgG-Fc fusion protein provided by the present disclosure can be therapeutically useful for cell therapy when engineered to be expressed on the membrane surface of cells that also express the IL-7R $\alpha\gamma\epsilon$ subunits. Adoptive immunotherapy using NK cells or using re-targeted chimeric antigen receptor (CAR) T-cells is currently being studied as a treatment for neoplasms and viral infections. One challenge with these cell therapies is the suboptimal sustained survival of the infused cells.

DNA encoding an IL-7R $\alpha\gamma\epsilon$ ligand fused to a membrane protein in such a way that the IL-7R $\alpha\gamma\epsilon$ ligand is expressed on the extracellular surface of a cell can be constructed using standard techniques. When the fusion protein comprising the IL-7R $\alpha\gamma\epsilon$ ligand is expressed, IL-7 receptors on the cell become activated leading to long-term persistence of the cell.

DNA encoding an IL-7R $\alpha\gamma\epsilon$ ligand can be incorporated into a cell and can be configured to produce an IL-7R $\alpha\gamma\epsilon$ ligand provided by the present disclosure. An IL-7R $\alpha\gamma\epsilon$ ligand can be secreted from the cell and can interact with the secreting cells (i.e., autocrine signaling) and/or cells in the vicinity of the secreting cell (i.e., paracrine signaling). A secreted IL-7R $\alpha\gamma\epsilon$ ligand or IL-7R $\alpha\gamma\epsilon$ IgG-Fc fusion protein provided by the present disclosure can be an IL-7R agonist and can be designed to localize near the secreting cell.

An IL-7R $\alpha\gamma\epsilon$ ligand or IL-7R $\alpha\gamma\epsilon$ IgG-Fc fusion protein provided by the present disclosure can be used to expand T-cells within a patient or within a biological sample. Methods of increasing the ratio of non-regulatory T-cells to Treg cells can comprise contacting a population of T-cells with an effective amount of an IL-7R $\alpha\gamma\epsilon$ ligand or IL-7R $\alpha\gamma\epsilon$ IgG-Fc fusion protein provided by the present disclosure. The ratio can be measured by determining the ratio of CD3+FOXP3+ cells to CD3+FOXP3-cells within the population of T-cells. A typical Treg frequency in human blood is 5% to 10% of the total CD4+CD3+ T-cells, however, in certain diseases this percentage may be lower or higher.

An IL-7R $\alpha\gamma\epsilon$ ligand or IL-7R $\alpha\gamma\epsilon$ IgG-Fc fusion protein can be used to expand T-cells. T-cells modified with chimeric antigen receptors (CARs), which redirect immune cell activity to target cancer cells have been demonstrated to exhibit improved antitumor responses. CARs can comprise an antibody-derived extracellular domain, which binds to the desired tumor-associated antigen (TAA) and triggers an intracellular signaling cascade to activate the immune cell against the target cells.

An IL-7R $\alpha\gamma\epsilon$ ligand or IL-7R $\alpha\gamma\epsilon$ IgG-Fc fusion protein that is immobilized to a surface such as a bead can be exposed to populations of T-cells in vitro or ex vivo to induce expansion of the cell population prior to transferring to a patient. CAR-T cells can be expanded by exposure to an immobilized form of an IL-7R $\alpha\gamma\epsilon$ ligand or IL-7R $\alpha\gamma\epsilon$ IgG-Fc fusion protein. An immobilized IL-7R $\alpha\gamma\epsilon$ ligand or IL-7R $\alpha\gamma\epsilon$ IgG-Fc fusion protein can be separated from the CAR-T cells prior to transferring the CAR-T cells to a patient.

CAR T-cells can be genetically engineered to co-express a tethered form of an IL-7R $\alpha\gamma\epsilon$ ligand provided by the

present disclosure to support in vivo persistence and maintenance of an immature state of differentiation and to exhibit in vivo antitumor activity.

An IL-7R α γ ligand or IL-7R α γ IgG-Fc fusion protein provided by the present disclosure can be used to mobilize and/or increase the number of T-cells and/or CD34+ stem cells in peripheral blood for increased yield from leukapheresis. The T cells and/or CD34+ stem cells can be manipulated ex vivo and used for cell therapy to treat cancer.

Assessing single patient response to therapy and qualifying a patient for optimal therapy are among the greatest challenges of modern healthcare and relate to trends in personalized medicine. An IL-7R α γ ligand or IL-7R α γ IgG-Fc fusion protein can have target selectivity, for example, for certain cancers and immune cells. An IL-7R α γ ligand or IL-7R α γ IgG-Fc fusion protein radiolabeled for positron emission tomography (PET) or Single Photon Emission Computed Tomography (SPECT) can be used to predict the targeting of the treatment based on a single-study, case-by-case patient analysis thus excluding patients that are expected not to benefit from treatment. PET/SPECT scans using IL-7R α γ ligands or IL-7R α γ IgG-Fc fusion proteins, once correlated to the concentration can provide a three-dimensional distribution map, which can then be used for macroscopic dose calculations.

An IL-7R α γ ligand or IL-7R α γ IgG-Fc fusion protein can comprise one or more imaging agents. An IL-7R α γ ligand or IL-7R α γ IgG-Fc fusion protein can direct and localize the compound to cells, populations of cells, and tissue expressing IL-7R. The imaging compounds can comprise one or more imaging agents such as radiolabels, fluorescent labels, enzymatic labels, or PET imaging agents.

The imaging agents can be used to determine the number of cells expressing IL-7R, the expression level of cells expressing IL-7R, or properties of IL-7R such as the binding affinity of IL-7R to a particular IL-7R α γ ligand or IL-7R α γ IgG-Fc fusion protein. The imaging agents can be used, for example, to evaluate cancer cells expressing IL-7R α subunit, or to evaluate Treg and/or Teff cells.

The label can be detected to determine a biodistribution of the compound in a patient or to assess the potential for therapeutic efficacy. For example, tumors expressing high levels of IL-7R can be attractive targets for a therapeutic IL-7R α γ ligand or IL-7R α γ IgG-Fc fusion protein provided by the present disclosure.

The imaging agents can be used to evaluate cells expressing IL-7R before therapy, during therapy, and/or following therapy.

Imaging agents comprising an IL-7R α γ ligand or IL-7R α γ IgG-Fc fusion protein can further comprise a moiety capable of binding to a cell surface and in particular to a protein expressed on the cell surface. The protein can be indicative of a certain cell type and is referred to as a cell surface marker. Imaging agents comprising both an IL-7R α γ ligand or IL-7R α γ IgG-Fc fusion protein and a cell surface marker can be used to assess cells, a population of cells, and/or a tissue expressing both IL-7R and the cell surface marker. Assessment can include determining the number of cells expressing both IL-7R and the cell surface marker, the expression levels of IL-7R and the cell surface marker, and/or the binding affinity of the imaging agent to IL-7R and/or the cell surface marker.

The imaging agents can be used to evaluate cells expressing IL-7R and the cell surface marker before therapy, during therapy, and/or following therapy.

An IL-7R α γ ligand or IL-7R α γ IgG-Fc fusion protein provided by the present disclosure can be labeled. Labeled compounds can be useful in diagnostics.

An IL-7R α γ ligand or IL-7R α γ IgG-Fc fusion protein provided by the present disclosure can be labeled with a detectable marker. The label can be used to determine a biodistribution of the compound in a patient or to assess the potential for therapeutic efficacy. For example, tumors expressing high levels of IL-7R can be attractive targets for selective IL-7R agonists and compounds comprising an IL-7R α γ ligand provided by the present disclosure.

An IL-7R α γ ligand or IL-7R α γ IgG-Fc fusion protein provided by the present disclosure include labeled compounds. A labeled compound can be a detectable marker, for example, a radiolabeled amino acid or an attachment of biotinyl moieties to a polypeptide, where the attached biotinyl moieties can be detected by marked avidin (e.g., streptavidin containing a fluorescent marker or enzymatic activity that can be detected by optical or colorimetric methods). Various methods of labeling polypeptides and glycoproteins are known in the art and can be used. Examples of labels for polypeptides include, for example, radioisotopes such as ^3H , ^{14}C , ^{35}S , ^{125}I , and ^{131}I , fluorescent labels such as FITC, rhodamine, and lanthanide phosphors, enzymatic labels such as horseradish peroxidase, β -galactosidase, luciferase, and alkaline phosphatase, biotinyl groups, predetermined polypeptide epitopes recognized by a secondary reporter such as leucine zipper pair sequences, binding sites for secondary antibodies, metal ligands, and epitope tags. A label can be attached by spacer arms of various lengths to reduce potential steric hindrance.

A nucleic acid provided by the present disclosure can encode for an IL-7R α γ ligand provided by the present disclosure.

A nucleic acid provided by the present disclosure can encode for an IL-7R α γ IgG-Fc fusion protein provided by the present disclosure.

A nucleic acid can be, for example, a deoxyribonucleic acid (DNA) or a ribonucleic acid (RNA) such as a messenger RNA (mRNA), a ribosomal RNA (rRNA), or an anti-sense RNA.

Nucleic acids/isolated polynucleotides encoding for an IL-7R α γ or IL-7R α γ IgG-Fc fusion protein provided by the present disclosure can be incorporated into expression vectors depending in part on the host cells used to produce the IL-7R α γ or IL-7R α γ IgG-Fc fusion protein. Generally, the nucleic acids can be operably linked to any number of regulatory elements such as, for example, promoters, origin of replication, selectable markers, ribosomal binding sites, and/or inducers. The expression vectors can be extra-chromosomal or integrating vectors.

The nucleic acids and/or expression vectors can be transformed into any number of different types of host cells including mammalian, bacterial, yeast, insect and/or fungal cells, with mammalian cells such as CHO cells.

A nucleic acid encoding an IL-7R α γ ligand can comprise a first nucleic acid sequence encoding an IL-7R α ligand; a second nucleic acid sequence encoding a peptidyl ligand linker; and a third nucleic acid sequence encoding an R γ ligand.

A nucleic acid encoding an IL-7R α γ IgG-Fc fusion protein can comprise a first nucleic acid sequence encoding the IL-7R α γ ligand provided by the present disclosure; and a second nucleic acid sequence encoding a fusion partner such as an IgG-Fc fragment. A nucleic acid encoding an IL-7R α γ fusion protein can comprise a nucleic acid encoding an IL-7R α γ ligand and the fusion partner such as an

IgG-Fc fragment. A nucleic acid encoding an IL-7R α γ C ligand fusion protein can further comprise a nucleic acid segment encoding a construct linker and a nucleic acid encoding an IL-7R α γ C ligand fusion protein can comprise a nucleic acid encoding an IL-7R α γ C ligand, the IgG-Fc fragment, or the IL-7R α γ C IgG-Fc fusion protein.

The fusion partner can comprise, for example, an IgG-Fc fragment, such as an IgG1-Fc fragment, an IgG2-Fc fragment, or an IgG4-Fc fragment.

A nucleic acid encoding an IL-7R α γ C IgG-Fc fusion protein can further comprise a nucleic acid encoding a peptidyl linker, where the peptidyl linker is configured to bind the IL-7R α γ C ligand to the IgG-Fc fragment.

A nucleic acid provided by the present disclosure can encode a fusion protein comprising a dimeric Fc-Fragment of IgG1, IgG2, or IgG4, an IL-7R α γ C ligand, and a linker binding the N-terminus of an IL-7R α γ C ligand to the C-terminus of one CH3 domain of the dimeric Fc-fragment.

A nucleic acid provided by the present disclosure can encode a fusion protein comprising a dimeric Fc-Fragment of IgG1, IgG2, or IgG4, two IL-7R α γ C ligands, and a linker binding the N-terminus of each of the two IL-7R α γ C ligands to the C-terminus of each CH3 domain of the dimeric Fc-fragment.

A nucleic acid provided by the present disclosure can encode a fusion protein comprising a heavy chain of an immunoglobulin molecule such as IgG1, IgG2, or IgG4, an IL-7R α γ C ligand, and an Fc linker bonding the N-terminus of the IL-7R α γ C ligand to the C-terminus of the Fc region.

A nucleic acid provided by the present disclosure can comprise a nucleic acid encoding for an IL-7R α γ C ligand or an IL-7R α γ C IgG-Fc fusion protein such as an IL-7R α γ C IgG-Fc fusion protein provided by the present disclosure and an RNA and/or DNA vaccine.

A nucleic acid provided by the present disclosure can comprise a nucleic acid encoding for an IL-7R α γ C IgG-Fc fusion protein vaccine construct. The vaccine can comprise, for example, a cancer vaccine or a viral vaccine.

A nucleic acid provided by the present disclosure can comprise a nucleic acid encoding for an IL-7R α γ C IgG-Fc fusion protein comprising a viral surface antigen.

A nucleic acid provided by the present disclosure can comprise a nucleic acid encoding for an IL-7R α γ C IgG-Fc fusion protein comprising a virus-like particle.

A nucleic acid provided by the present disclosure can encode for an IL-7R α ligand comprising an amino acid sequence of any one of SEQ ID NO: 1, a substituted amino acid sequence of any one of SEQ ID NO: 1, and/or can encode for an amino acid sequence comprising an amino acid sequence having greater than 60%, greater than 70%, greater than 80%, greater than 85%, greater than 90%, or greater than 95% sequence similarity to any one of: SEQ ID NO: 1.

A nucleic acid provided by the present disclosure can encode for an R γ C ligand comprising an amino acid sequence of any one of SEQ ID NO: 11, a substituted amino acid sequence of any one of SEQ ID NO: 11, and/or can encode for an amino acid sequence comprising an amino acid sequence having greater than 60%, greater than 70%, greater than 80%, greater than 85%, greater than 90%, or greater than 95% sequence similarity to any one of SEQ ID NO: 11.

A nucleic acid provided by the present disclosure can encode for an IL-7R α γ C ligand comprising an amino acid sequence of any one of SEQ ID NOS: 21-32, or can encode for an amino acid sequence comprising an amino acid sequence having greater than 60%, greater than 70%, greater

than 80%, greater than 85%, greater than 90%, or greater than 95% sequence similarity to any one of SEQ ID NOS: 21-32; and an IL-7R α γ C ligand comprising an amino acid sequence of any one of SEQ ID NOS: 21-32, or can encode for an amino acid sequence comprising an amino acid sequence having greater than 60%, greater than 70%, greater than 80%, greater than 85%, greater than 90%, or greater than 95% sequence similarity to any one of SEQ ID NOS: 21-32.

A nucleic acid provided by the present disclosure can encode for an IL-7R α γ C ligand comprising an amino acid sequence of any one of SEQ ID NOS: 27-32 or can encode for an amino acid sequence comprising an amino acid sequence having greater than 60%, greater than 70%, greater than 80%, greater than 85%, greater than 90%, or greater than 95% sequence similarity to any one of SEQ ID NOS: 27-32.

A nucleic acid provided by the present disclosure can encode for an IL-7R α γ C IgG-Fc fusion protein comprising an amino acid sequence of any one of SEQ ID NOS: 44-55 or can encode for an amino acid sequence comprising an amino acid sequence having greater than 60%, greater than 70%, greater than 80%, greater than 85%, greater than 90%, or greater than 95% sequence similarity to any one of SEQ ID NOS: 44-55.

A nucleic acid provided by the present disclosure can encode for an IL-7R α γ C IgG-Fc fusion protein comprising an IL-7R α ligand comprising an amino acid sequence of any one of SEQ ID NO: 1 or an amino acid sequence comprising an amino acid sequence having greater than 60%, greater than 70%, greater than 80%, greater than 85%, greater than 90%, or greater than 95% sequence similarity to SEQ ID NO: 1; and an R γ C ligand comprising an amino acid sequence of SEQ ID NO: 11 or an amino acid sequence comprising an amino acid sequence having greater than 60%, greater than 70%, greater than 80%, greater than 85%, greater than 90%, or greater than 95% sequence similarity to any one of SEQ ID NO: 11.

A nucleic acid provided by the present disclosure can encode for an IL-7R α γ C IgG-Fc fusion protein having an amino acid sequence of any one of SEQ ID NO: 45 or an amino acid sequence comprising an amino acid sequence having greater than 60%, greater than 70%, greater than 80%, greater than 85%, greater than 90%, or greater than 95% sequence similarity to SEQ ID NO: 45.

Aspects of the invention further include a host cell comprising an expression vector comprising a nucleic acid encoding an IL-7R α ligand, an R γ C ligand, an IL-7R α γ C ligand, or an IL-7R α γ C fusion protein such as an IL-7R α γ C IgG-Fc fusion protein provided by the present disclosure.

Methods provided by the present disclosure include methods of making an IL-7R α ligand, an R γ C ligand, an IL-7R α γ C ligand, or an IL-7R α γ C fusion protein such as an IL-7R α γ C IgG-Fc fusion protein provided by the present disclosure, comprising culturing a host cell, wherein the host cell comprises an expression vector comprising a nucleic acid encoding an IL-7R α ligand, an R γ C ligand, an IL-7R α γ C ligand, or an IL-7R α γ C fusion protein such as an IL-7R α γ C IgG-Fc fusion protein provided by the present disclosure, under conditions where the IL-7R α γ C fusion protein such as an IL-7R α γ C IgG-Fc fusion protein is expressed, and recovering the expressed IL-7R α γ C fusion protein such as an IL-7R α γ C IgG-Fc fusion protein.

The invention is further defined by one or more of the following aspects:

Aspect 1. An IL-7R α yc ligand comprising: an IL-7R α ligand comprising an amino acid sequence of SEQ ID NO: 1 or an amino acid sequence having greater than 70% sequence similarity to SEQ ID NO: 1; and an Ryc ligand comprising an amino acid sequence of SEQ ID NO: 11 or an amino acid sequence having greater than 70% sequence similarity to SEQ ID NO: 11.

Aspect 2. The IL-7R α yc ligand of aspect 1, wherein the IL-7R α yc ligand comprises: an IL-7R α ligand comprising an amino acid sequence of SEQ ID NO: 1 and an Ryc ligand comprising an amino acid sequence of SEQ ID NO: 11.

Aspect 3. The IL-7R α yc ligand of aspect 1, wherein the IL-7R α yc ligand comprises: an IL-7R α ligand comprising an amino acid sequence having greater than 70% sequence similarity to SEQ ID NO: 1; and an Ryc ligand comprising an amino acid sequence having greater than 70% sequence similarity to SEQ ID NO: 11.

Aspect 4. The IL-7R α yc ligand of aspect 1, wherein the IL-7R α yc ligand comprises: an IL-7R α ligand comprising an amino acid sequence based on SEQ ID NO: 1 and having from 1 to 10, such as from 1 to 5 amino acid substitutions; and an Ryc ligand comprising an amino acid sequence based on SEQ ID NO: 11 and having from 1 to 10, such as from 1 to 5 amino acid substitutions.

Aspect 5. The IL-7R α yc ligand of any one of aspects 1 to 4, wherein each of the IL-7R α ligand and the Ryc ligand independently comprises from 1 to 6 glycines (G) on the N-terminus, on the C-terminus, or on both the N-terminus and the C-terminus.

Aspect 6. The IL-7R α yc ligand of any one of aspects 1 to 5, wherein the IL-7R α ligand and the Ryc ligand are bound together through a ligand linker.

Aspect 7. The IL-7R α yc ligand of aspect 6, wherein the C-terminus of the IL-7R α ligand is bound to the N-terminus of the Ryc ligand through the ligand linker.

Aspect 8. The IL-7R α yc ligand of any one of aspects 6 to 7, wherein the ligand linker is a flexible ligand linker.

Aspect 9. The IL-7R α yc ligand of any one of aspects 6 to 8, wherein the ligand linker comprises an amino acid sequence selected from any one of SEQ ID NO: 113-136.

Aspect 10. The IL-7R α yc ligand of any one of aspects 6 to 8, wherein the ligand linker comprises an amino acid sequence having SEQ ID NO: 132.

Aspect 11. The IL-7R α yc ligand of any one of aspects 1 to 10, wherein the IL-7R α yc ligand comprises: an amino acid sequence of any one of SEQ ID NO: 21-26 or an amino acid sequence having greater than 70% sequence similarity to any one of SEQ ID NO: 21-26; and X¹ is selected from an amino acid sequence of any one of SEQ ID NO: 101-148.

Aspect 12. The IL-7R α yc ligand of aspect 11, wherein X¹ is selected from any one of SEQ ID NO: 137-143.

Aspect 13. The IL-7R α yc ligand of aspect 11, wherein X¹ has an amino acid sequence of SEQ ID NO: 139.

Aspect 14. The IL-7R α yc ligand of any one of aspects 1 to 13, wherein the IL-7R α yc ligand comprises an amino acid sequence of any one of SEQ ID NO: 27-32, or an amino acid sequence having greater than 70% sequence similarity to any one of SEQ ID NO: 27-32.

Aspect 15. The IL-7R α yc ligand of any one of aspects 1 to 13, wherein the IL-7R α yc ligand comprises an amino acid sequence of SEQ ID NO: 32 or an amino acid sequence having greater than 70% sequence similarity to SEQ ID NO: 32.

Aspect 16. The IL-7R α yc ligand of any one of aspects 1 to 15, wherein the IL-7R α yc ligand binds to the hu-IL-7R α subunit with an IC50 of less than 1 μ M.

Aspect 17. The IL-7R α yc ligand of any one of aspects 1 to 16, wherein the IL-7R α yc ligand binds to the hu-Ryc subunit with an IC50 of less than 1 μ M.

Aspect 18. The IL-7R α yc ligand of any one of aspects 1 to 17, wherein the IL-7R α yc ligand activates STAT5 phosphorylation in TF-1-7R α cells with an EC50 of less than 1 μ M.

Aspect 19. The IL-7R α yc ligand of any one of aspects 1 to 18, wherein the IL-7R α yc ligand is a hu-IL-7R agonist.

Aspect 20. The IL-7R α yc ligand of any one of aspects 1 to 19, wherein the IL-7R α yc ligand binds to the cyno-IL-7R α subunit with an IC50 of less than 1 μ M.

Aspect 21. The IL-7R α yc ligand of any one of aspects 1 to 20, wherein the IL-7R α yc ligand binds to the cyno-Ryc subunit with an IC50 of less than 1 μ M.

Aspect 22. The IL-7R α yc ligand of any one of aspects 1 to 21, wherein the IL-7R α yc ligand is a cyno-IL-7R agonist.

Aspect 23. An IL-7R α yc IgG-Fc fusion fragment comprising the IL-7R α yc ligand of any one of aspects 1 to 22 bound to an IgG-Fc fragment.

Aspect 24. The IL-7R α yc IgG-Fc fusion fragment of aspect 23, wherein the IgG-Fc fragment is selected from an IgG1-Fc fragment, an IgG2-Fc fragment, and an IgG4-Fc fragment.

Aspect 25. The IL-7R α yc IgG-Fc fusion fragment of aspect 23, wherein the IgG-Fc fragment is an IgG2-Fc fragment.

Aspect 26. The IL-7R α yc IgG-Fc fusion fragment of any one of aspects 23 to 25, wherein the IL-7R α yc ligand is bound to the IgG-Fc fragment through an IgG-Fc linker.

Aspect 27. The IL-7R α yc IgG-Fc fusion fragment of aspect 26, wherein the IgG-Fc linker comprises a flexible IgG-Fc linker.

Aspect 28. The IL-7R α yc IgG-Fc fusion fragment of any one of aspects 26 to 27, wherein the IgG-Fc linker comprises an amino acid sequence of any one of SEQ ID NO: 150-179.

Aspect 29. The IL-7R α yc IgG-Fc fusion fragment of any one of aspects 26 to 27, wherein the IgG-Fc linker comprises an amino acid sequence of SEQ ID NO: 163.

Aspect 30. The IL-7R α yc IgG-Fc fusion fragment of any one of aspects 26 to 29, wherein the N-terminus of the IL-7R α yc ligand is bound to the IgG-Fc linker.

Aspect 31. The IL-7R α yc IgG-Fc fusion fragment of any one of aspects 26 to 30, wherein the N-terminus of the IgG-Fc linker is bound to the CH3 domain of the IgG-Fc fragment.

Aspect 32. The IL-7R α yc IgG-Fc fusion fragment of any one of aspects 23 to 31, wherein the IL-7R α yc ligand is bound to the C-terminus of each CH3 domain of the IgG-Fc fragment.

Aspect 33. The IL-7R α yc IgG-Fc fusion fragment of aspect 23, wherein the IL-7R α yc IgG-Fc fusion fragment comprises an amino acid sequence having greater than 70% sequence similarity to any one of SEQ ID NO: 44-55.

Aspect 34. The IL-7R α yc IgG-Fc fusion fragment of aspect 23, wherein the IL-7R α yc IgG-Fc fusion fragment comprises an amino acid sequence of any one of SEQ ID NO: 44-55.

Aspect 35. The IL-7R α yc IgG-Fc fusion p fragment of aspect 23, wherein the IL-7R α yc IgG-Fc fusion fragment comprises an amino acid sequence having greater than 70% sequence similarity to SEQ ID NO: 45.

Aspect 36. The IL-7R $\alpha\gamma\epsilon$ IgG-Fc fusion fragment of aspect 23, wherein the IL-7R $\alpha\gamma\epsilon$ IgG-Fc fusion fragment comprises an amino acid sequence having SEQ ID NO: 45.

Aspect 37. The IL-7R $\alpha\gamma\epsilon$ IgG-Fc fusion fragment of aspect 23, wherein the IL-7R $\alpha\gamma\epsilon$ IgG-Fc fusion fragment is derived from an amino acid sequence of SEQ ID NO: 45 and having from 1 to 10 amino acid substitutions.

Aspect 38. The IL-7R $\alpha\gamma\epsilon$ IgG-Fc fusion fragment of any one of aspects 23 to 37, wherein the IL-7R $\alpha\gamma\epsilon$ IgG-Fc fusion fragment binds to the hu-IL-7R α subunit with an IC50 of less than 1 μ M.

Aspect 39. The IL-7R $\alpha\gamma\epsilon$ IgG-Fc fusion fragment of any one of aspects 23 to 38, wherein the IL-7R $\alpha\gamma\epsilon$ IgG-Fc fusion protein binds to the hu-IL-7R $\gamma\epsilon$ subunit with an IC50 of less than 1 μ M.

Aspect 40. The IL-7R $\alpha\gamma\epsilon$ IgG-Fc fusion fragment of any one of aspects 23 to 39, wherein the IL-7R $\alpha\gamma\epsilon$ IgG-Fc fusion fragment activates STAT5 phosphorylation in TF-1-7R α cells with an EC50 of less than 1 μ M.

Aspect 41. The IL-7R $\alpha\gamma\epsilon$ IgG-Fc fusion fragment of any one of aspects 23 to 40, wherein the IL-7R $\alpha\gamma\epsilon$ IgG-Fc fusion fragment is a hu-IL-7R agonist.

Aspect 42. The IL-7R $\alpha\gamma\epsilon$ IgG-Fc fusion fragment of any one of aspects 23 to 41, wherein the IL-7R $\alpha\gamma\epsilon$ IgG-Fc fusion protein binds to the cyno-IL-7R α subunit with an IC50 of less than 1 μ M.

Aspect 43. The IL-7R $\alpha\gamma\epsilon$ IgG-Fc fusion fragment of any one of aspects 23 to 42, wherein the IL-7R $\alpha\gamma\epsilon$ IgG-Fc fusion fragment binds to the cyno-IL-7R $\gamma\epsilon$ subunit with an IC50 of less than 1 μ M.

Aspect 44. The IL-7R $\alpha\gamma\epsilon$ IgG-Fc fusion fragment of any one of aspects 23 to 42, wherein the IL-7R $\alpha\gamma\epsilon$ IgG-Fc fusion fragment activates STAT5 phosphorylation in TF-1-7R α cells with an EC50 of less than 1 μ M.

Aspect 45. The IL-7R $\alpha\gamma\epsilon$ IgG-Fc fusion fragment of any one of aspects 22 to 44, wherein the IL-7R $\alpha\gamma\epsilon$ IgG-Fc fragment is a cyno-IL-7R agonist.

Aspect 46. An IL-7R $\alpha\gamma\epsilon$ IgG-Fc fusion protein comprising: a first IL-7R $\alpha\gamma\epsilon$ IgG-Fc fusion fragment of any one of aspects 23 to 45; and a second IL-7R $\alpha\gamma\epsilon$ IgG-Fc fusion fragment of any one of aspects 23 to 45, wherein the first IL-7R $\alpha\gamma\epsilon$ IgG-Fc fusion fragment and the second first IL-7R $\alpha\gamma\epsilon$ IgG-Fc fusion fragment are bound at the hinge region through disulfide bonds.

Aspect 47. The IL-7R $\alpha\gamma\epsilon$ IgG-Fc fusion protein of aspect 46, wherein the first IL-7R $\alpha\gamma\epsilon$ IgG-Fc fusion fragment and the second IL-7R $\alpha\gamma\epsilon$ IgG-Fc fusion fragment have the same amino acid sequence.

Aspect 48. The IL-7R $\alpha\gamma\epsilon$ IgG-Fc fusion protein of aspect 46, wherein the first IL-7R $\alpha\gamma\epsilon$ IgG-Fc fusion fragment and the second IL-7R $\alpha\gamma\epsilon$ IgG-Fc fusion fragment comprise a different amino acid sequence.

Aspect 49. The IL-7R $\alpha\gamma\epsilon$ IgG-Fc fusion protein of aspect 46, wherein the first IL-7R $\alpha\gamma\epsilon$ IgG-Fc fusion fragment and the second IL-7R $\alpha\gamma\epsilon$ IgG-Fc fusion fragment comprise a different IL-7R α ligand.

Aspect 50. The IL-7R $\alpha\gamma\epsilon$ IgG-Fc fusion protein of aspect 46, wherein the first IL-7R $\alpha\gamma\epsilon$ IgG-Fc fusion fragment and the second IL-7R $\alpha\gamma\epsilon$ IgG-Fc fusion fragment comprise a different R $\gamma\epsilon$ ligand.

Aspect 51. The IL-7R $\alpha\gamma\epsilon$ IgG-Fc fusion protein of aspect 46, wherein the first IL-7R $\alpha\gamma\epsilon$ IgG-Fc fusion fragment and the second IL-7R $\alpha\gamma\epsilon$ IgG-Fc fusion fragment comprise a different ligand linker.

Aspect 52. The IL-7R $\alpha\gamma\epsilon$ IgG-Fc fusion protein of aspect 46, wherein the first IL-7R $\alpha\gamma\epsilon$ IgG-Fc fusion fragment and the second IL-7R $\alpha\gamma\epsilon$ IgG-Fc fusion fragment comprise a different IL-7R $\alpha\gamma\epsilon$ ligand.

Aspect 53. The IL-7R $\alpha\gamma\epsilon$ IgG-Fc fusion protein of aspect 46, wherein the first IL-7R $\alpha\gamma\epsilon$ IgG-Fc fusion fragment and the second IL-7R $\alpha\gamma\epsilon$ IgG-Fc fusion fragment comprise a different IgG-Fc linker. Aspect 54. The IL-7R $\alpha\gamma\epsilon$ IgG-Fc fusion protein of aspect 46, wherein the first IL-7R $\alpha\gamma\epsilon$ IgG-Fc fusion fragment and the second IL-7R $\alpha\gamma\epsilon$ IgG-Fc fusion fragment comprise a different IgG-Fc fragment.

Aspect 55. A pharmaceutical composition comprising the IL-7R $\alpha\gamma\epsilon$ ligand of any one of aspects 1 to 22.

Aspect 56. A pharmaceutical composition comprising the IL-7R $\alpha\gamma\epsilon$ IgG-Fc fusion protein of any one of aspects 23 to 55.

Aspect 57. A method of treating a cancer, an inflammatory disease, an autoimmune disease, an immunodeficiency disease, or a viral disease in a patient comprising administering to a patient in need of such treatment a therapeutically effective amount of the IL-7R $\alpha\gamma\epsilon$ ligand of any one of aspects 1 to 22, or the IL-7R $\alpha\gamma\epsilon$ IgG-Fc fusion protein of any one of aspects 23 to 55.

Aspect 58. A method of treating a cancer, an inflammatory disease, an autoimmune disease, an immunodeficiency disease, or a viral disease in a patient comprising administering to a patient in need of such treatment a therapeutically effective amount of the IL-7R $\alpha\gamma\epsilon$ ligand of any one of aspects 1 to 22, or the IL-7R $\alpha\gamma\epsilon$ IgG-Fc fusion protein of any one of aspects 23 to 55.

Aspect 59. A nucleic acid encoding for the IL-7R $\alpha\gamma\epsilon$ ligand of any one of aspects 1 to 22.

Aspect 60. A nucleic acid encoding for the IL-7R $\alpha\gamma\epsilon$ IgG-Fc fusion protein of any one of aspects 23 to 55.

Aspect 61. The nucleic acid of aspect 60, wherein the IL-7R $\alpha\gamma\epsilon$ ligand has an amino acid sequence of any one of SEQ ID NO: 27-32 or has greater than 70% sequence similarity to an amino acid sequence of any one of SEQ ID NO: 27-32.

Aspect 62. The nucleic acid of aspect 60, wherein the IL-7R $\alpha\gamma\epsilon$ ligand has an amino acid sequence of SEQ ID NO: 32 or has greater than 70% sequence similarity to an amino acid sequence of SEQ ID NO: 32.

Aspect 63. A nucleic acid encoding for the IL-7R $\alpha\gamma\epsilon$ IgG-Fc fusion protein of any one of aspects 23 to 55.

Aspect 64. The nucleic acid of aspect 63, wherein the IL-7R $\alpha\gamma\epsilon$ IgG-Fc fusion protein has an amino acid sequence of any one of SEQ ID NO: 44-55 or has greater than 70% sequence similarity to an amino acid sequence of any one of SEQ ID NO: 44-55.

Aspect 65. The nucleic acid of aspect 63, wherein the IL-7R $\alpha\gamma\epsilon$ IgG-Fc fusion protein has an amino acid sequence of SEQ ID NO: 45 or having greater than 70% sequence similarity to an amino acid sequence of SEQ ID NO: 45.

EXAMPLES

The following examples describe in detail methods of synthesizing IL-7R $\alpha\gamma\epsilon$ ligands, methods of synthesizing IL-7R $\alpha\gamma\epsilon$ IgG-Fc fusions, and methods of determining the activity of IL-7R $\alpha\gamma\epsilon$ ligands and IL-7R $\alpha\gamma\epsilon$ IgG-Fc fusions provided by the present disclosure and the experimental results. The following examples also describe in detail methods for determining properties of the IL-7R $\alpha\gamma\epsilon$ ligands and IL-7R $\alpha\gamma\epsilon$ IgG-Fc fusions provided by the present disclosure. It will be apparent to those skilled in the art that

many modifications, both to materials and methods, may be practiced without departing from the scope of the invention.

Example 1

Chemical Synthesis of IL-7R α Ligands and R γ c Ligands

2-Chlorotrityl resin (1 g, 1.5 mmole/g, from Anaspec) was washed with DMF (2 \times), and then allowed to stand in 50 mL DMF for 10 min. The swollen resin was treated with an activated solution of Fmoc-glycine prepared from 5 eq. of amino acid and 5 eq. of HATU dissolved at 0.5 M in DMF, followed by the addition of 10 eq. of DIEA, and the mixture was gently stirred for 30 min at 25 $^{\circ}$ C. The resin was washed (DMF, THF, DCM, and MeOH) and dried to yield the Fmoc-protected resin. Fmoc groups were then removed by gently shaking the resin with 30% piperidine in DMF for 20 min, followed by washing (DMF, THF, DCM, and MeOH), and drying. The resin was then subjected to repeated cycles of Fmoc-amino acid couplings with HATU activation and Fmoc removal with piperidine to build a desired amino acid sequence. Except for examples with four cysteine residues in the sequence, standard 95% TFA-labile amino acid side-chain protecting groups were used. With compounds with four cysteines, for the two cysteine residues proximal to the resin, Trt protection was used, and for the two cysteine residues distal to the resin, Acn protection was used. After Fmoc removal from the final amino acid of the dimer sequence, in some cases, the terminal amine groups were acylated with acetic anhydride (10 eq.) and DIEA (20 eq.) in DMF for 20 min, followed by washing as described above.

The completed peptide was cleaved from the resin by suspension in a solution of TFA (95 vol %), water (2.5 vol %), and trisopropylsilane (2.5 vol %) for 3 h at 25 $^{\circ}$ C. The TFA solution was cooled to 5 $^{\circ}$ C. and poured into Et₂O to precipitate the peptide. Filtration and drying under reduced pressure gave the desired peptide. Purification via preparative HPLC with a C18 column afforded the pure peptide with the two C-terminal thiol groups in a reduced state. This peptide was dissolved in 20% DMSO/water (1 mg dry weight peptide/mL) and allowed to stand at 25 $^{\circ}$ C. for 36 h, and then purified by reverse phase HPLC to provide the peptide with the two C-terminal thiols linked by a disulfide bridge. In compounds containing four cysteines, the two N-terminal Acn-protected cysteine residues were then deprotected by dissolving 0.1 mmole of peptide in 25 mL of 50% acetic acid/H₂O and 2.5 mL of 1 M HCl and adding 5 mL of 0.1 M iodine (in glacial acetic acid; 5 eq.) dropwise with stirring under a nitrogen atmosphere. The deprotection/oxidation reaction was allowed to proceed for 2 h at 25 $^{\circ}$ C. with frequent monitoring (analytical HPLC) to ensure complete reaction. The reaction was stopped by addition of ice-cooled diethyl ether (9 volume eq.). The resulting solution was cooled on dry ice (3 min), the ether solution carefully decanted, and the resulting light-yellow solid purified by preparative reverse phase HPLC (95%) to yield the final peptide dimer having an IL-7R α ligand and an R γ c ligand.

Example 2

Competitive Binding to the IL-7R α Subunit, to the IL-7R γ c Subunit, and to IL-7R

Binding of the synthetic IL-7R α ligands to IL-7R α was evaluated using a competition binding ELISA. Microtiter

plate wells were coated with IL-7R α -Fc (CD127 protein, Fc tag; ECD 21-236; ACROBiosystems, Inc. Cat. #ILA-H5258) at 1 μ g/mL; 50 μ L per well in PBS for at least 1 h. The plate was washed once with wash buffer (200 μ L, PBS containing 0.05% Tween $^{\circledR}$ -20 (Sigma)). Wells were blocked with blocking buffer (PBS containing 1% BSA (BSA Fraction V; VWR Cat. No. 97061-416) for 1 h. A serial dilution of the peptides was prepared, at twice the final concentration, in assay buffer (PBS containing 0.5% BSA and 0.05% Tween $^{\circledR}$ -20) in a 96-well polypropylene plate. A terminal biotinylated form of the reference IL-7R α peptide ligand having SEQ ID NO: 300 (VHRIPWCTLDPGGLQCAWLRQMGG) was used to make a precomplex with NeutrAvidin-HRP (NA-HRP; ThermoFisher Cat. No. 31030) (Precomplex referred to as bnPeptide::NA-HRP). The bnPeptide::NA-HRP precomplex was prepared by mixing 1.5 μ L 100 μ M biotinylated peptide, 2 μ L NA-HRP and 11.5 PBS and incubated at 4 $^{\circ}$ C. for at least 45 min. After blocking the wells, the plate was washed with a plate washer and serial dilutions of the peptides were added (50 μ L/well) and the plate was incubated at 4 $^{\circ}$ C. for 1 h on a plate shaker. The bnPeptide:NA-HRP precomplex was diluted to 40 nM and, without washing, 50 μ L was added to each assay well. The plate was returned to a temperature of 4 $^{\circ}$ C. and incubated for 45 min. The plate was washed using the plate washer and cold wash buffer. Fifty (50) μ L of TMB One Component HRP Microwell substrate (TMB; Surmodics Cat. #TMBW-1000-01) was then added to each well, and the wells were incubated for 1-10 min at 25 $^{\circ}$ C. Fifty (50) μ L of a solution (Surmodics Cat. #LSTP-0100-0) was then added and the plate read at 450 nm.

A similar method was used to assess the binding of R γ c ligands to the IL-7R γ c subunit; and a similar method was used to assess the binding of IL-7R α γ c ligands to the IL-7R α subunit, to the IL-7R γ c subunit, and to IL-7R.

For example, competitive binding of the IL-7R α γ c ligand having SEQ ID NO: 30 to the hu-IL-7R α subunit and to the hu-IL-7R γ c subunit is shown in FIGS. 1 and 2, respectively.

Example 3

STAT5 Phosphorylation in TF-1-7 α Cells Induced by IL-7R α γ c Ligands

IL-7R α γ c ligands were evaluated for induction of STAT5 phosphorylation in TF-1-7 α cells. TF-1-7 α cells were derived from the growth factor-dependent human erythroleukemia cell line TF-1 (ATCC No. CRL-2003), which naturally express common γ c receptors (R γ c) but not IL-7R α . The cells were engineered to be IL-7 responsive by transfection with human full-length IL-7R α . A cell line expressing higher levels of IL-7R α was selected by growth in IL-7, and both IL-7R α and R γ c subunit expression levels were verified by qPCR analysis.

To test compounds for induction of STAT5 phosphorylation, TF-1-7 α cells were starved overnight at 5 \times 10⁵ cells/mL in starvation medium (RPMI 1640+2.5 g/L glucose+5% FBS+2 mM L-glutamine+1 mM NaPyr+ 10 mM HEPES with no GM-CSF or rhIL-7 supplement) in T75 flasks. The following day, cells were plated in 96-well V-bottom plates at 2 \times 10⁵ cells/well. Three-fold serial dilutions of IL-7R α γ c ligands or IL-7 in starvation media were added to the cells and incubated for 30 min at 37 $^{\circ}$ C. Cell extracts were prepared by adding a mixture of 10 \times Cell Lysis Buffer (Cell Signaling Technology #9803) and 1 \times HALT Phosphatase and Protease Inhibitor Cocktail (Thermo Fisher #78442) directly to the wells. The plates were agitated at 25 $^{\circ}$ C. for 5 min to prepare cell extracts for immediate use or stored at -80 $^{\circ}$ C.

Detection of pSTAT5 was performed using a PathScan® Phospho-Stat5 (Tyr694) Sandwich ELISA Kit (Cell Signaling Technology #7113). Cell extracts were added to micro-wells that were pre-coated with a mouse anti-phospho-STAT5 antibody and incubated overnight at 4° C. Wells were then washed with PBS and bound phospho-STAT5 (Tyr694) was detected by adding a rabbit anti-STAT5 detection antibody and incubating for 1 h at 37° C. Wells were washed with PBS and an anti-rabbit IgG HRP-linked antibody was added to each well. After a final wash TMB substrate solution was added to measure the amount of HRP in each well. Absorbance at 450 nm was read in a microplate reader. The signal that was produced is proportional to the quantity of phosphorylated STAT5 in each cell extract.

STAT5 phosphorylation of TF-1-7R α cells induced by the IL-7R α yc ligand having SEQ ID NO: 30 is shown in FIG. 3.

Example 4

Recombinant Fusion Proteins Incorporating an IL-7R α yc Ligand

Mammalian expression vectors were constructed to express IL-7R α yc ligands linked to full-length human IgG, or to Fc-fragments consisting of the CH2 and CH3 domains of the heavy chain and hinge regions of human IgG2. Each vector included strong constitutive promoter (CMV or hEF1-HTLV) and an IL-7 signal peptide sequence for secretion of the fusion protein into the culture media. Vectors were designed to enable peptide ligands to be fused to either the N- or C-terminus of the immunoglobulin proteins and to incorporate construct linkers of varying lengths between the IL-7R α yc ligands and IgG. Fusion proteins were transiently expressed in 293 human embryonic kidney cells (FreeStyle® 293-F) by transfecting plasmid DNA into the cells using polyethyleneimine reagent PEI MAX (Polysciences, Inc.). Transfected cells were grown in FreeStyle® 293 Expression Medium (ThermoFisher) in shaker flasks in a 37° C. humidified CO₂ incubator on an orbital shaker rotating at 125 rpm. Cultures were harvested 96 h post-transfection by centrifugation and the secreted fusion proteins were purified from the supernatants using Protein A affinity chromatography.

Protein A agarose resin was mixed with culture supernatant and incubated at room temperature for several hours. The resin was then washed three times with PBS and bound IL-7R α yc IgG-Fc fusion was eluted with 0.1 M glycine buffer (pH 2.8). Eluates were neutralized with 1 M Tris buffer and quantified by measuring absorbance at 280 nm using a NanoDrop® spectrophotometer. Protein concentrations were determined using calculated extinction coefficients derived from the primary sequence of the protein. Size exclusion chromatography was used to remove high molecular weight impurities prior to measuring the activities of the fusion proteins in bioassays.

The amino acid sequences of the IL-7R α yc IgG2-Fc fusion proteins used in the experimental examples has the amino acid sequence of SEQ ID NO: 45. The hu-IgG2-Fc-fragment refers to the Fc region consisting of the CH2 and CH3 domains of the IgG2 heavy chain and the hinge region. The first and second cysteines of the hinge region were replaced with serine to prevent detrimental disulfide bridges. The last amino acid (lysine) of the Fc region was replaced

with an alanine for fusion stability. The N-terminus of IgG2-Fc fusion constructs may include Ala-Pro-Leu (derived from InvivoGen vector).

A schematic of the structure is shown in FIG. 4.

Example 5

IL-7R α yc IgG-Fc Fusion Protein Pharmacokinetics in Non-Human Primates

A pharmacokinetic study of an IL-7R α yc IgG2-Fc fusion protein was performed in non-human primates. The IL-7R α yc IgG2-Fc fusion having SEQ ID NO: 45 was administered intravenously (IV), subcutaneously (SC), or intramuscularly (IM) with a single dose of 1 mg/kg into each non-human primate (n=10). Blood samples were collected at times post-dose into serum separator vials. Samples were centrifuged at 10,000× g for 5 min at 4° C. followed by transferring the serum to a new tube. Samples were frozen and stored at -80° C. prior to testing.

The TF-1-7R α STAT5 phosphorylation bioassay was used to quantify the amount of the IL-7R α yc IgG2-Fc fusion in each of the serum samples. Three-fold serial dilutions of each serum sample or a compound reference standard in starvation media were added to the cells and incubated for 30 mins with the cells. Cells extracts were prepared and the quantity of phosphorylated STAT5 was determined as described in Example 3. The IL-7R α yc IgG2-Fc fusion protein concentration in each serum sample was calculated using a standard curve generated from the reference standard. The results are presented in FIG. 5. The bioavailability % F for IM administration was 117 and the bioavailability % F for SC administration was 112.

The absolute lymphocyte counts of each blood sample was determined using a hematology analyzer. The results are presented in FIG. 6.

The pharmacokinetics of IL-7R α yc IgG2-Fc fusion protein administered at doses from 0.1 mg/kg to 3.0 mg/kg was determined using a similar method. The C_{max} and AUC_{0-inf} of the plasma IL-7R α yc IgG2-Fc fusion protein concentration following SC administration of from 0.1 mg/kg to 3.0 mg/kg of the IL-7R α yc IgG2-Fc fusion protein having SEQ ID NO: 45 to non-human primates is shown in FIGS. 7A and 7B, respectively.

The CD8+ T cell and CD4+ T cell populations in the peripheral blood were determined by flow cytometry at the indicated time point following a single subcutaneous injection of various doses of the IL-7R α yc IgG2-Fc fusion protein having SEQ ID NO: 45 to non-human primates. The data for the total lymphocyte population, CD8+ T cell population, and CD4+ T cell population, are shown in FIGS. 8A-8D, FIGS. 9A-9D, and FIGS. 10A-10D, respectively.

Example 6

In Vitro STAT5 Phosphorylation in Human and Cynomolgus Monkey PBMCs

Frozen PBMCs from 5 healthy human donors or Cynomolgus monkeys were rested overnight and stained for viability, followed by cell surface antibody staining on ice. Cells were washed and incubated with the IL-7R α yc IgG2-Fc fusion protein having SEQ ID NO: 45 or IL-7 for 30 min at 37° C. After washing, the cells were fixed, permeabilized, stained with anti-pSTAT5 antibody and FoxP3 antibody, and analyzed by flow cytometry. Antibody-stained cells were analyzed immediately by flow cytometry using a Novo-

55

cyte® Advanteon™ Instrument (Agilent) and the data analyzed using FlowJo™ software.

Induction of pSTAT5 in resting human PBMCs treated with either the IL-7Rαγc IgG2-Fc fusion protein having SEQ ID NO: 45 or IL-7 is shown for CD8+ T, CD4+ T, Treg, and NK cells in FIGS. 11A-11D, respectively.

Induction of pSTAT5 in resting Cynomolgus monkey PBMCs treated with either the IL-7Rαγc IgG2-Fc fusion protein having SEQ ID NO: 45 or IL-7 is shown for CD8+ T, CD4+ T, Treg, and NK cells in FIGS. 11E-11H, respectively.

Example 7

Proliferation of Human CD4+ T, CD8+ T, Treg and NK Cells

Frozen PBMCs from 5 healthy donors were rested overnight or activated with CD3 antibody and left untreated or treated with 100 nM of the IL-7Rαγc IgG2-Fc fusion protein having SEQ ID NO: 45 or with 1 nM IL-7 in culture. On days 3, 7, 16, and 30, cell aliquots were taken to determine Ki-67 expression in immune cells and total cell counts in the culture.

PBMCs and cell culture: Frozen human PBMCs from 5 healthy donors (Stem Cell Technologies, cat no. 70025.2) were thawed and rested overnight at 37° C., 5% CO₂ in CTS™ OpTmizer™ T Cell Expansion SFM (ThermoFisher Scientific No. A1048501). Four million cells were cultured in the plate coated with or without 10 ng/mL of CD3 antibody (Clone SP34-2) and in the presence or absence of 100 nM of the IL-7Rαγc IgG2-Fc fusion protein having SEQ ID NO: 45 or 1 nM IL-7. Fresh media containing the IL-7Rαγc IgG2-Fc fusion protein having SEQ ID NO: 45 and IL-7 were provided every 4-5 days.

Flow cytometry: On day 3, day 7, day 16, and day 30, cell aliquots were taken, and cell surface staining was performed using antibodies, followed by fixable viability dye staining. For Ki-67 and FoxP3 staining, surfaced stained cells were fixed and permeabilized according to the manufacturer's instruction and analyzed immediately using a Novocyte® Advanteon™ instrument (Agilent). The data were analyzed using FlowJo™ software. Fluorescent Minus One (FMO) controls were used to draw gates. Percentages of Ki67+ cell populations were expressed as average ±SEM.

Cell counting: Cultures were initially plated at 4×10⁶ cells in 2 mL per well. At each assay time point, 50 μL/well of cells were taken from each culture and incubated with 200 μL of the viability dye solution. The Novocyte® Advanteon™ flow cytometer was set up to analyze precisely 50 μL (12.5 μL original culture volume), which allowed the calculation of the absolute live cell counts. Because the culture volumes change over time due to splitting and removal, dilution factors were considered when calculating the total number of cells.

FIGS. 12A-12D show Ki-67 expression in resting CD8+ T, CD4+ T, Treg and NK cells, respectively.

FIGS. 13A-13D show total cell counts in resting CD8+ T, CD4+ T, Treg and NK cells, respectively.

Example 8

Expansion of Tscm in PBMCs

Frozen PBMCs from 5 healthy donors were rested overnight or activated with CD3 antibody and treated with vehicle, 100 nM of the IL-7Rαγc IgG2-Fc fusion protein

56

having SEQ ID NO: 45, or with 1 nM IL-7 in a serum-free culture medium. On days 3, 7, 16, and 30, cell aliquots were analyzed by flow cytometry for memory T cell populations and cell counts.

PBMCs and cell culture: Frozen human PBMCs from 5 healthy donors (Stem Cell Technologies, cat no. 70025.2) were thawed and rested overnight at 37° C., 5% CO₂ in CTS™ OpTmizer™ T Cell Expansion SFM (ThermoFisher Scientific No. A1048501). Four million cells were cultured in the plate coated with or without 10 ng/mL of CD3 antibody (Clone SP34-2) and in the presence or absence of 100 nM of the IL-7Rαγc IgG2-Fc fusion protein or 1 nM IL-7. Fresh media containing the IL-7Rαγc IgG2-Fc fusion protein and IL-7 were provided every 4-5 days.

Flow cytometry: On day 3, day 7, day 16, and day 30, cell aliquots were taken, and cell surface

staining was performed using antibodies, followed by fixable viability dye staining. For Ki-67 and FoxP3 staining, surfaced stained cells were fixed and permeabilized according to the manufacturer's instruction and analyzed immediately using the Novocyte® Advanteon™ instrument (Agilent). The data were analyzed using FlowJo™ software. Fluorescent Minus One (FMO) controls were used to draw gates. Percentages of Ki67+ cell populations were expressed average ±SEM.

Cell counting: Cultures were initially plated at 4×10⁶ cells in 2 mL per well. At each assay time point, 50 μL/well of cells were taken from each culture and incubated with 200 μL of the viability dye solution. A Novocyte® Advanteon™ flow cytometer was set up to analyze precisely 50 μL (12.5 μL original culture volume), which allowed the calculation of the absolute live cell counts. Because the culture volumes change over time due to splitting and removal, dilution factors were considered when calculating the total number of cells.

Changes in memory T-cell populations mediated by the IL-7Rαγc IgG2-Fc fusion protein having SEQ ID NO: 45 or by IL-7 in PBMCs is shown in FIGS. 14A-14E and in FIGS. 15A-15C.

FIGS. 14A-14E show the total cell number of CD8+ Tn, CD8+ Tscm, CD8+ Tcm, CD8+ Tem, and CD8+ Temra cells, respectively, without treatment (FIG. 14A) or following exposure to either the IL-7Rαγc IgG2-Fc fusion protein or to IL-7 with time.

FIGS. 15A-15C show the total cell number of CD8+ Tn, CD8+ Tscm, CD8+ Tcm, CD8+ Tem, and CD8+ Temra cells, without treatment (FIG. 15A) or following exposure to the IL-7Rαγc IgG2-Fc fusion protein having SEQ ID NO: 45 (FIG. 15B) or to IL-7 (FIG. 15C).

FIGS. 16A and 16B show the relative cell populations at day 0 and at day 30, respectively.

FIG. 17A-17D show the expansion of Tscm cells in resting PBMCs (FIGS. 17A-17B) and in CD3-activated PBMCs (FIGS. 17C-17D).

Example 9

T-Cell Populations in Humanized Mice Treated with an IL-7Rαγc IgG2-Fc Fusion Protein

NSG (NOD scid gamma) mice separately engrafted with human CD34+ cells from two donors were dosed once intravenously with 1 mg/kg hu-Fc or with 1 mg/kg of the IL-7Rαγc IgG2-Fc fusion protein having SEQ ID NO: 45. On day 7, peripheral blood was collected, processed and stained for the flow cytometry using a 12-color panel, followed by flow cytometry data acquisition and analysis to determine Ki-67+ cells in immune populations (FIGS. 18A-

57

18E). On day 12, terminal blood samples and spleens were collected for immune profiling (FIGS. 19A-19E). Markers used for memory T cell populations (FIGS. 20A-20E and FIGS. 21A-21E) are shown in Table 5. TCF1+ expression (FIGS. 22A-22E) of memory cells in spleen was also determined. Population gates were drawn based on FMO controls. Statistical analysis was done using Student's T-Test.

TABLE 5

Markers for memory T cell populations.				
Tn	CD45RA+	CCR7+	CD28+	CD95-
Tscm	CD45RA+	CCR7+	CD28+	CD95+

58

TABLE 5-continued

Markers for memory T cell populations.				
Tcm	CD45RA-	CCR7+	CD28+	CD95+
Ttm	CD45RA-	CCR7-	CD28+	CD95+
Tem	CD45RA-	CCR7-	CD28-	CD95+
Tte	CD45RA+	CCR7-	CD28-	CD95+

10 Finally, it should be noted that there are alternative ways of implementing the embodiments disclosed herein. Accordingly, the present embodiments are to be considered as illustrative and not restrictive, and the claims are not to be limited to the details given herein but may be modified within the scope and equivalents thereof.

SEQUENCE LISTING

```

Sequence total quantity: 302
SEQ ID NO: 1      moltype = AA length = 21
FEATURE          Location/Qualifiers
source           1..21
                 mol_type = protein
                 organism = synthetic construct

SEQUENCE: 1
WGIPWCTLDP GSLQCAWLGH H                               21

SEQ ID NO: 2      moltype = length =
SEQUENCE: 2
000

SEQ ID NO: 3      moltype = length =
SEQUENCE: 3
000

SEQ ID NO: 4      moltype = length =
SEQUENCE: 4
000

SEQ ID NO: 5      moltype = length =
SEQUENCE: 5
000

SEQ ID NO: 6      moltype = length =
SEQUENCE: 6
000

SEQ ID NO: 7      moltype = length =
SEQUENCE: 7
000

SEQ ID NO: 8      moltype = length =
SEQUENCE: 8
000

SEQ ID NO: 9      moltype = length =
SEQUENCE: 9
000

SEQ ID NO: 10     moltype = length =
SEQUENCE: 10
000

SEQ ID NO: 11     moltype = AA length = 14
FEATURE          Location/Qualifiers
source           1..14
                 mol_type = protein
                 organism = synthetic construct

SEQUENCE: 11
VVCQDWEGVE LCWQ                                       14

SEQ ID NO: 12     moltype = length =
SEQUENCE: 12
000

SEQ ID NO: 13     moltype = length =
SEQUENCE: 13
    
```

-continued

```

000
SEQ ID NO: 14      moltype = length =
SEQUENCE: 14
000

SEQ ID NO: 15      moltype = length =
SEQUENCE: 15
000

SEQ ID NO: 16      moltype = length =
SEQUENCE: 16
000

SEQ ID NO: 17      moltype = length =
SEQUENCE: 17
000

SEQ ID NO: 18      moltype = length =
SEQUENCE: 18
000

SEQ ID NO: 19      moltype = length =
SEQUENCE: 19
000

SEQ ID NO: 20      moltype = length =
SEQUENCE: 20
000

SEQ ID NO: 21      moltype = AA length = 135
FEATURE
source             Location/Qualifiers
                  1..135
                  mol_type = protein
                  organism = synthetic construct
VARIANT           22..121
                  note = This region may encompass one of the following
                  sequences: (P)n where n is an integer from 1 to 20, (P)n
                  where n is an integer from 5 to 15, (PA)n where n is an
                  integer from 1 to 20, (PA)n where n is an integer from 5
                  to 15, (P)nG where n is an integer from 1 to 20, (P)nG
                  where n is an integer from 5 to 15, (PA)nG where n is an
                  integer from 1 to 20, (PA)nG where n is an integer from 5
                  to 15, (P)nGG where n is an integer from 1 to 20, (P)nGG
                  where n is an integer from 5 to 15, (PA)nGG where n is an
                  integer from 1 to 20, (PA)nGG where n is an integer from 5
                  to 15, (G)n where n is an integer from 1 to 20, (G)n where
                  n is an integer from 1 to 15, (GS)n where n is an integer
                  from 1 to 20, (GS)n where n is an integer from 1 to 15,
                  (GGS)n where n is an integer from 1 to 20, (GGS)n where n
                  is an integer from 1 to 15, (GGGS)n where n is an integer
                  from 1 to 20, (GGGS)n where n is an integer from 1 to 15,
VARIANT           22..121
                  note = CONT. FROM ABOVE: (GGGS)n where n is an integer
                  from 1 to 20, (GGGS)n where n is an integer from 1 to
                  8, (GGGS)n where n is an integer from 1 to 10, (GGGS)n
                  where n is an integer from 1 to 5, GGGGS, GGGGSGGGS,
                  GGGSGGGSGGGGS, GGGSGGGSGGGSGGGGS,
                  GGGSGGGSGGGSGGGSGGGGS, (GGGS)nG where n is an integer
                  from 1 to 10, (GGGS)nG where n is an integer from 1 to 5,
                  GGGSG, GGGSGGGSG, GGGSGGGSGGGSG,
                  GGGSGGGSGGGSGGGSG, GGGSGGGSGGGSGGGSGGGSG,
                  (GGGS)nGG where n is an integer from 1 to 10, (GGGS)nGG
                  where n is an integer from 1 to 5, GGGSGG, GGGSGGGSGG,
                  GGGSGGGSGGGSGG, GGGSGGGSGGGSGGGSGG, or
                  GGGSGGGSGGGSGGGSGGGSGG
SEQUENCE: 21
WGIPWCTLDP GSLQCAWL GK HXXXXXXXXX XXXXXXXXXXXX XXXXXXXXXXXX XXXXXXXXXXXX 60
XXXXXXXXXX XXXXXXXXXXXX XXXXXXXXXXXX XXXXXXXXXXXX XXXXXXXXXXXX XXXXXXXXXXXX 120
XVVCQDWEGV ELCWQ                                           135

SEQ ID NO: 22      moltype = AA length = 136
FEATURE
source             Location/Qualifiers
                  1..136
                  mol_type = protein
                  organism = synthetic construct
VARIANT           23..122
                  note = This region may encompass one of the following
                  sequences: (P)n where n is an integer from 1 to 20, (P)n

```

-continued

where n is an integer from 5 to 15, (PA)n where n is an integer from 1 to 20, (PA)n where n is an integer from 5 to 15, (P)nG where n is an integer from 1 to 20, (P)nG where n is an integer from 5 to 15, (PA)nG where n is an integer from 1 to 20, (PA)nG where n is an integer from 5 to 15, (P)nGG where n is an integer from 1 to 20, (P)nGG where n is an integer from 5 to 15, (PA)nGG where n is an integer from 1 to 20, (PA)nGG where n is an integer from 5 to 15, (G)n where n is an integer from 1 to 20, (G)n where n is an integer from 1 to 15, (GS)n where n is an integer from 1 to 20, (GS)n where n is an integer from 1 to 15, (GGS)n where n is an integer from 1 to 20, (GGS)n where n is an integer from 1 to 15, (GGGS)n where n is an integer from 1 to 20, (GGGS)n where n is an integer from 1 to 15, (GGGS)n where n is an integer from 1 to 15, 23..122

VARIANT
 note = CONT. FROM ABOVE: (GGGS)n where n is an integer from 1 to 20, (GGGS)n where n is an integer from 1 to 8, (GGGS)n where n is an integer from 1 to 10, (GGGS)n where n is an integer from 1 to 5, GGGGS, GGGSGGGGS, GGGSGGGSGGGGS, GGGSGGGSGGGSGGGGS, GGGSGGGSGGGSGGGSGGGGS, (GGGS)nG where n is an integer from 1 to 10, (GGGS)nG where n is an integer from 1 to 5, GGGGSG, GGGSGGGGSG, GGGSGGGSGGGGSG, GGGSGGGSGGGSGGGGSG, GGGSGGGSGGGSGGGSGGGSG, (GGGS)nGG where n is an integer from 1 to 10, (GGGS)nGG where n is an integer from 1 to 5, GGGGSGG, GGGSGGGGSGG, GGGSGGGSGGGSGG, GGGSGGGSGGGSGGGSGG, or GGGSGGGSGGGSGGGSGGGSGG

SEQUENCE: 22
 GWGIPWCTLD PGS LQCAWLK KXXXXXXXXXXXXXXXXXXXX 60
 XXXXXXXXXXXXXXXXXXXXXXX XXXXXXXXXXXXXXX 120
 XXVVCQDWEG VELCWQ 136

SEQ ID NO: 23 moltype = AA length = 137
 FEATURE Location/Qualifiers
 source 1..137
 mol_type = protein
 organism = synthetic construct

VARIANT
 22..121
 note = This region may encompass one of the following sequences: (P)n where n is an integer from 1 to 20, (P)n where n is an integer from 5 to 15, (PA)n where n is an integer from 1 to 20, (PA)n where n is an integer from 5 to 15, (P)nG where n is an integer from 1 to 20, (P)nG where n is an integer from 5 to 15, (PA)nG where n is an integer from 1 to 20, (PA)nG where n is an integer from 5 to 15, (P)nGG where n is an integer from 1 to 20, (P)nGG where n is an integer from 5 to 15, (PA)nGG where n is an integer from 1 to 20, (PA)nGG where n is an integer from 5 to 15, (G)n where n is an integer from 1 to 20, (G)n where n is an integer from 1 to 15, (GS)n where n is an integer from 1 to 15, (GGS)n where n is an integer from 1 to 20, (GGS)n where n is an integer from 1 to 15, (GGGS)n where n is an integer from 1 to 15, 22..121

VARIANT
 22..121
 note = CONT. FROM ABOVE: (GGGS)n where n is an integer from 1 to 20, (GGGS)n where n is an integer from 1 to 8, (GGGS)n where n is an integer from 1 to 10, (GGGS)n where n is an integer from 1 to 5, GGGGS, GGGSGGGGS, GGGSGGGSGGGGS, GGGSGGGSGGGSGGGGS, GGGSGGGSGGGSGGGSGGGGS, (GGGS)nG where n is an integer from 1 to 10, (GGGS)nG where n is an integer from 1 to 5, GGGGSG, GGGSGGGGSG, GGGSGGGSGGGGSG, GGGSGGGSGGGSGGGGSG, GGGSGGGSGGGSGGGGSG, (GGGS)nGG where n is an integer from 1 to 10, (GGGS)nGG where n is an integer from 1 to 5, GGGGSGG, GGGSGGGGSGG, GGGSGGGSGGGSGG, GGGSGGGSGGGSGGGSGG, or GGGSGGGSGGGSGGGSGGGSGG

SEQUENCE: 23
 WGIPWCTLDP GSLQCAWLK HXXXXXXXXXXXXXXXXXXXX 60
 XXXXXXXXXXXXXXXXXXXXXXX XXXXXXXXXXXXXXX 120
 XVVCQDWEGV ELCWQGG 137

SEQ ID NO: 24 moltype = AA length = 138
 FEATURE Location/Qualifiers
 source 1..138
 mol_type = protein
 organism = synthetic construct

-continued

VARIANT 23..122
note = This region may encompass one of the following sequences: (P)n where n is an integer from 1 to 20, (P)n where n is an integer from 5 to 15, (PA)n where n is an integer from 1 to 20, (PA)n where n is an integer from 5 to 15, (P)nG where n is an integer from 1 to 20, (P)nG where n is an integer from 5 to 15, (PA)nG where n is an integer from 1 to 20, (PA)nG where n is an integer from 5 to 15, (P)nGG where n is an integer from 1 to 20, (P)nGG where n is an integer from 5 to 15, (PA)nGG where n is an integer from 1 to 20, (PA)nGG where n is an integer from 5 to 15, (G)n where n is an integer from 1 to 20, (G)n where n is an integer from 1 to 15, (GS)n where n is an integer from 1 to 15, (GGS)n where n is an integer from 1 to 20, (GGS)n where n is an integer from 1 to 15, (GGGS)n where n is an integer from 1 to 15, (GGGS)n where n is an integer from 1 to 20, (GGGS)n where n is an integer from 1 to 15, (GGGS)n where n is an integer from 1 to 20, (GGGS)n where n is an integer from 1 to 15,

VARIANT 23..122
note = CONT. FROM ABOVE: (GGGS)n where n is an integer from 1 to 20, (GGGS)n where n is an integer from 1 to 8, (GGGS)n where n is an integer from 1 to 10, (GGGS)n where n is an integer from 1 to 5, GGGGS, GGGSGGGGS, GGGSGGGSGGGGS, GGGSGGGSGGGSGGGGS, GGGSGGGSGGGSGGGSGGGGS, (GGGS)nG where n is an integer from 1 to 10, (GGGS)nG where n is an integer from 1 to 5, GGGSG, GGGSGGGSG, GGGSGGGSGGGSG, GGGSGGGSGGGSGGGSG, GGGSGGGSGGGSGGGSGGGSG, (GGGS)nGG where n is an integer from 1 to 10, (GGGS)nGG where n is an integer from 1 to 5, GGGSGG, GGGSGGGSGG, GGGSGGGSGGGSGG, GGGSGGGSGGGSGGGSGG, or GGGSGGGSGGGSGGGSGGGSGG

SEQUENCE: 24
GWGIPWCTLD PGSLQCAWLK KHXXXXXXXXXXXXXXXXXXXXXXXXXX 60
XXXXXXXXXXXX XXXXXXXXXXXX XXXXXXXXXXXX XXXXXXXXXXXX 120
XXVVCQDWEV VELCWQGG 138

SEQ ID NO: 25 moltype = AA length = 139
FEATURE Location/Qualifiers
source 1..139
mol_type = protein
organism = synthetic construct

VARIANT 24..123
note = This region may encompass one of the following sequences: (P)n where n is an integer from 1 to 20, (P)n where n is an integer from 5 to 15, (PA)n where n is an integer from 1 to 20, (PA)n where n is an integer from 5 to 15, (P)nG where n is an integer from 1 to 20, (P)nG where n is an integer from 5 to 15, (PA)nG where n is an integer from 1 to 20, (PA)nG where n is an integer from 5 to 15, (P)nGG where n is an integer from 1 to 20, (P)nGG where n is an integer from 5 to 15, (PA)nGG where n is an integer from 1 to 20, (PA)nGG where n is an integer from 5 to 15, (G)n where n is an integer from 1 to 20, (G)n where n is an integer from 1 to 15, (GS)n where n is an integer from 1 to 15, (GGS)n where n is an integer from 1 to 20, (GGS)n where n is an integer from 1 to 15, (GGGS)n where n is an integer from 1 to 20, (GGGS)n where n is an integer from 1 to 15,

VARIANT 24..123
note = CONT. FROM ABOVE: (GGGS)n where n is an integer from 1 to 20, (GGGS)n where n is an integer from 1 to 8, (GGGS)n where n is an integer from 1 to 10, (GGGS)n where n is an integer from 1 to 5, GGGGS, GGGSGGGGS, GGGSGGGSGGGGS, GGGSGGGSGGGSGGGGS, GGGSGGGSGGGSGGGSGGGGS, (GGGS)nG where n is an integer from 1 to 10, (GGGS)nG where n is an integer from 1 to 5, GGGSG, GGGSGGGSG, GGGSGGGSGGGSG, GGGSGGGSGGGSGGGSG, GGGSGGGSGGGSGGGSGGGSG, (GGGS)nGG where n is an integer from 1 to 10, (GGGS)nGG where n is an integer from 1 to 5, GGGSGG, GGGSGGGSGG, GGGSGGGSGGGSGG, GGGSGGGSGGGSGGGSGG, or GGGSGGGSGGGSGGGSGGGSGG

SEQUENCE: 25
GGWIPWCTL DPGLQCAWLK GKHXXXXXXXXXXXXXXXXXXXXXXXXXX 60
XXXXXXXXXXXX XXXXXXXXXXXX XXXXXXXXXXXX XXXXXXXXXXXX 120
XXVVCQDWEV GVELCWQGG 139

SEQ ID NO: 26 moltype = AA length = 140
FEATURE Location/Qualifiers

-continued

```

source          1..140
                mol_type = protein
                organism = synthetic construct
VARIANT        25..124
                note = This region may encompass one of the following
                sequences: (P)n where n is an integer from 1 to 20, (P)n
                where n is an integer from 5 to 15, (PA)n where n is an
                integer from 1 to 20, (PA)n where n is an integer from 5
                to 15, (P)nG where n is an integer from 1 to 20, (P)nG
                where n is an integer from 5 to 15, (PA)nG where n is an
                integer from 1 to 20, (PA)nG where n is an integer from 5
                to 15, (P)nGG where n is an integer from 1 to 20, (P)nGG
                where n is an integer from 5 to 15, (PA)nGG where n is an
                integer from 1 to 20, (PA)nGG where n is an integer from 5
                to 15, (G)n where n is an integer from 1 to 20, (G)n where
                n is an integer from 1 to 15, (GS)n where n is an integer
                from 1 to 20, (GS)n where n is an integer from 1 to 15,
                (GGS)n where n is an integer from 1 to 20, (GGS)n where n
                is an integer from 1 to 15, (GGGS)n where n is an integer
                from 1 to 20, (GGGS)n where n is an integer from 1 to 15,
                25..124
VARIANT        note = CONT. FROM ABOVE: (GGGS)n where n is an integer
                from 1 to 20, (GGGS)n where n is an integer from 1 to
                8, (GGGS)n where n is an integer from 1 to 10, (GGGS)n
                where n is an integer from 1 to 5, GGGGS, GGGSGGGGS,
                GGGSGGGSGGGGS, GGGSGGGSGGGSGGGGS,
                GGGSGGGSGGGSGGGSGGGGS, (GGGS)nG where n is an integer
                from 1 to 10, (GGGS)nG where n is an integer from 1 to 5,
                GGGSG, GGGSGGGSG, GGGSGGGSGGGSG,
                GGGSGGGSGGGSGGGSG, GGGSGGGSGGGSGGGSGGGSG,
                (GGGS)nGG where n is an integer from 1 to 10, (GGGS)nGG
                where n is an integer from 1 to 5, GGGSGG, GGGSGGGSGG,
                GGGSGGGSGGGSGG, GGGSGGGSGGGSGGGSGG, or
                GGGSGGGSGGGSGGGSGGGSGG

SEQUENCE: 26
GGGWGIPWCT LDPGSLQCAW LGKHXKXXXXX XXXXXXXXXXX XXXXXXXXXXX XXXXXXXXXXX 60
XXXXXXXXXX XXXXXXXXXXX XXXXXXXXXXX XXXXXXXXXXX XXXXXXXXXXX XXXXXXXXXXX 120
XXXXVVCQDW EGVLCWQGG                                     140

SEQ ID NO: 27      moltype = AA length = 42
FEATURE          Location/Qualifiers
source          1..42
                mol_type = protein
                organism = synthetic construct

SEQUENCE: 27
WGIPWCTLDP GSLQCAWLK HGGGGSGGVV CQDWEGVELC WQ                                     42

SEQ ID NO: 28      moltype = AA length = 43
FEATURE          Location/Qualifiers
source          1..43
                mol_type = protein
                organism = synthetic construct

SEQUENCE: 28
GWGIPWCTLD PGLQCAWLK KHGGGGSGGV VCQDWEGVEL CWQ                                     43

SEQ ID NO: 29      moltype = AA length = 44
FEATURE          Location/Qualifiers
source          1..44
                mol_type = protein
                organism = synthetic construct

SEQUENCE: 29
WGIPWCTLDP GSLQCAWLK HGGGGSGGVV CQDWEGVELC WQGG                                     44

SEQ ID NO: 30      moltype = AA length = 45
FEATURE          Location/Qualifiers
source          1..45
                mol_type = protein
                organism = synthetic construct

SEQUENCE: 30
GWGIPWCTLD PGLQCAWLK KHGGGGSGGV VCQDWEGVEL CWQGG                                     45

SEQ ID NO: 31      moltype = AA length = 46
FEATURE          Location/Qualifiers
source          1..46
                mol_type = protein
                organism = synthetic construct

SEQUENCE: 31
GGWIPWCTL DPGSLQCAWL GKHHGGGGSGG VVCQDWEGVE LCWQGG                                     46
    
```

-continued

SEQ ID NO: 32 moltype = AA length = 47
FEATURE Location/Qualifiers
source 1..47
 mol_type = protein
 organism = synthetic construct

SEQUENCE: 32
GGGWGIPWCT LDPGSLQCAW LGKHGGGGSG GVVCQDWEGV ELCWQGG 47

SEQ ID NO: 33 moltype = length =
SEQUENCE: 33
000

SEQ ID NO: 34 moltype = length =
SEQUENCE: 34
000

SEQ ID NO: 35 moltype = length =
SEQUENCE: 35
000

SEQ ID NO: 36 moltype = length =
SEQUENCE: 36
000

SEQ ID NO: 37 moltype = length =
SEQUENCE: 37
000

SEQ ID NO: 38 moltype = length =
SEQUENCE: 38
000

SEQ ID NO: 39 moltype = length =
SEQUENCE: 39
000

SEQ ID NO: 40 moltype = length =
SEQUENCE: 40
000

SEQ ID NO: 41 moltype = AA length = 227
FEATURE Location/Qualifiers
source 1..227
 mol_type = protein
 organism = Homo sapiens

SEQUENCE: 41
DKTHTCPCPCP APELLGGPSV FLPPPKPKDT LMISRTPEVT CVVVDVSHED PEVKFNWYVD 60
GVEVHNAKTK PREEQYASTY RVVSVLTVLH QDWLNGKEYK CKVSNKALPA PIEKTISKAK 120
GQPREPQVYTT LPPSRDELTK NQVSLTCLVK GFYPSDIAVE WESNGQPENN YKTTTPVLDS 180
DGSFFLYSKL TVDKSRWQQG NVFSCSVMHE ALHNHYTQKS LSLSPGA 227

SEQ ID NO: 42 moltype = AA length = 228
FEATURE Location/Qualifiers
source 1..228
 mol_type = protein
 organism = Homo sapiens

SEQUENCE: 42
ERKSSVECPCP CPAPPVAGPS VFLFPPKPKD TLMISRTPEV TCVVVDVSHE DPEVQFNWYV 60
DGVEVHNAKT KPREEQFNST FRVSVLTVV HQDWLNGKEY KCKVSNKGLP APIEKTISKT 120
KGQPREPQVY TLPPSREEMT KNQVSLTCLV KGFYPSDIAV EWESNGQPEN NYKTTTPMLD 180
SDGSFFLYSK LTVDKSRWQQ GNVFSCSVMH EALHNHYTQK SLSLSPGA 228

SEQ ID NO: 43 moltype = AA length = 227
FEATURE Location/Qualifiers
source 1..227
 mol_type = protein
 organism = Homo sapiens

SEQUENCE: 43
APPCPPCPAP EFEGGPSVFL FPPKPKDTLM ISRTPEVTCV VVDVVSQEDPE VQFNWYVDGV 60
EVHNAKTKPR EEQFNSTYRV VSVLTVLHQD WLNGKEYKCK VSNKGLGSSI EKTISKAKGQ 120
PREPQVYITL PSQEEMTKNQ VSLTCLVKGF YPSDIAVEWE SNGQPENNYK TTPPVLDSDG 180
SFFLYSRLTV DKSRWQEGNV FSCSVMHEAL HNHYTQKSLS LSLGART 227

SEQ ID NO: 44 moltype = AA length = 294
FEATURE Location/Qualifiers
source 1..294
 mol_type = protein
 organism = synthetic construct

SEQUENCE: 44

-continued

n is an integer from 1 to 15, (GS)n where n is an integer from 1 to 20, (GS)n where n is an integer from 1 to 15, (GGS)n where n is an integer from 1 to 20, (GGS)n where n is an integer from 1 to 15, (GGGS)n where n is an integer from 1 to 20, (GGGS)n where n is an integer from 1 to 15, (GGGS)n where n is an integer from 1 to 15, (GGGS)n where n is an integer from 1 to 15, 272..371

VARIANT note = CONT. FROM ABOVE: (GGGS)n where n is an integer from 1 to 20, (GGGS)n where n is an integer from 1 to 8, (GGGS)n where n is an integer from 1 to 10, (GGGS)n where n is an integer from 1 to 5, GGGGS, GGGSGGGGS, GGGSGGGSGGGGS, GGGSGGGSGGGSGGGGS, (GGGS)nG where n is an integer from 1 to 10, (GGGS)nG where n is an integer from 1 to 5, GGGGSG, GGGSGGGGSG, GGGSGGGSGGGGSG, GGGSGGGSGGGSGGGGSG, GGGSGGGSGGGSGGGSGGGGSG, (GGGS)nGG where n is an integer from 1 to 10, (GGGS)nGG where n is an integer from 1 to 5, GGGGSGG, GGGSGGGSGG, GGGSGGGSGGGSGG, GGGSGGGSGGGSGGGSGG, or GGGSGGGSGGGSGGGSGGGSGG

SEQUENCE: 50
 DKTHTCPPCP APELLGGPSV FLFPPKPKDT LMISRTPEVT CVVVDVSHED PEVKFNWYVD 60
 GVEVHNAKTK PREEQYASTY RIVSVLTVLH QDWLNGKEYK CKVSNKALPA PIEKTIKAK 120
 GQPREPQVYT LPPSRDELTK NQVSLTCLVK GFYPSDIAVE WESNGQPENN YKTTTPVLDL 180
 DGSFFLYSKL TVDKSRWQQG NVPFSCVMHE ALHNHYTQKS LSLSPGAGSG SGGSGSGSGS 240
 SGGSGSGSGG WGIPWCTLDP GSLQCAWLK HXXXXXXXXX XXXXXXXXXXX XXXXXXXXXXX 300
 XXXXXXXXXXX XXXXXXXXXXX XXXXXXXXXXX XXXXXXXXXXX XXXXXXXXXXX XXXXXXXXXXX 360
 XXXXXXXXXXX XVVCQDWEGV ELCWQGG 387

SEQ ID NO: 51 moltype = AA length = 388
 FEATURE Location/Qualifiers
 source 1..388
 mol_type = protein
 organism = synthetic construct

VARIANT 273..372
 note = This region may encompass one of the following sequences: (P)n where n is an integer from 1 to 20, (P)n where n is an integer from 5 to 15, (PA)n where n is an integer from 1 to 20, (PA)n where n is an integer from 5 to 15, (P)nG where n is an integer from 1 to 20, (P)nG where n is an integer from 5 to 15, (PA)nG where n is an integer from 1 to 20, (PA)nG where n is an integer from 5 to 15, (P)nGG where n is an integer from 1 to 20, (P)nGG where n is an integer from 5 to 15, (PA)nGG where n is an integer from 1 to 20, (PA)nGG where n is an integer from 5 to 15, (G)n where n is an integer from 1 to 20, (G)n where n is an integer from 1 to 15, (GS)n where n is an integer from 1 to 20, (GS)n where n is an integer from 1 to 15, (GGS)n where n is an integer from 1 to 20, (GGS)n where n is an integer from 1 to 15, (GGGS)n where n is an integer from 1 to 20, (GGGS)n where n is an integer from 1 to 15, (GGGS)n where n is an integer from 1 to 15, 273..372

VARIANT note = CONT. FROM ABOVE: (GGGS)n where n is an integer from 1 to 20, (GGGS)n where n is an integer from 1 to 8, (GGGS)n where n is an integer from 1 to 10, (GGGS)n where n is an integer from 1 to 5, GGGGS, GGGSGGGGS, GGGSGGGSGGGGS, GGGSGGGSGGGSGGGGS, (GGGS)nG where n is an integer from 1 to 10, (GGGS)nG where n is an integer from 1 to 5, GGGGSG, GGGSGGGGSG, GGGSGGGSGGGGSG, GGGSGGGSGGGSGGGGSG, GGGSGGGSGGGSGGGSGGGGSG, (GGGS)nGG where n is an integer from 1 to 10, (GGGS)nGG where n is an integer from 1 to 5, GGGGSGG, GGGSGGGSGG, GGGSGGGSGGGSGG, GGGSGGGSGGGSGGGSGG, or GGGSGGGSGGGSGGGSGGGSGG

SEQUENCE: 51
 ERKSVCECPP CPAPPVAGPS VFLFPPKPKD TLMISRTPEV TCVVVDVSHED DPEVQFNWYV 60
 DGVEVHNAKT KPREEQFNST FRVSVLTVV HQDWLNGKEY KCKVSNKGLP APIEKTISK 120
 KGQPREPQVY TLPPSREEMT KNQVSLTCLV KGFYPSDIAV EWESNGQPEN NYKTTTPMLD 180
 SDGSFFLYSK LTVDKSRWQQ GNVFSCVMHE EALHNHYTQK SLSLSPGAGS SGGSGSGSGS 240
 SGGSGSGSGG GWGIPWCTLD PGSLSQCAWLK HXXXXXXXXX XXXXXXXXXXX XXXXXXXXXXX 300
 XXXXXXXXXXX XXXXXXXXXXX XXXXXXXXXXX XXXXXXXXXXX XXXXXXXXXXX XXXXXXXXXXX 360
 XXXXXXXXXXX XVVCQDWEG VELCWQGG 387

SEQ ID NO: 52 moltype = AA length = 387
 FEATURE Location/Qualifiers
 source 1..387
 mol_type = protein
 organism = synthetic construct

VARIANT 272..371

-continued

GGGSGGGSGGGSG, GGGSGGGSGGGSGGGSG,
GGGSGGGSGGGSGGGSGGGSG, (GGGS)nG where n is an integer
from 1 to 10, (GGGS)nG where n is an integer from 1 to 5,
GGGSG, GGGSGGGSG, GGGSGGGSGGGSG,
GGGSGGGSGGGSGGGSG, GGGSGGGSGGGSGGGSGGGSG,
(GGGGS)nGG where n is an integer from 1 to 10, (GGGS)nGG
where n is an integer from 1 to 5, GGGSGG, GGGSGGGSGG,
GGGSGGGSGGGSGG, GGGSGGGSGGGSGGGSGG, or
GGGSGGGSGGGSGGGSGGGSGG

SEQUENCE: 54
ERKSSVECPP CPAPPVAGPS VFLFPPKPKD TLMISRTPEV TCVVVDVSHE DPEVQFNWYV 60
DGVEVHNAKT KPREEQFNST FRVVSULTVV HQDWLNGKEY KCKVSNKGLP APIEKTISK 120
KGQPREPQVY TLPPSREEMT KNQVSLTCLV KGFYPSDIAV EWESNGQPEN NYKTTTPMLD 180
SDGSFFLYSK LTVDKSRWQQ GNVFSCSVMH EALHNHYTQK SLSLSPAGAX XXXXXXXXXXXX 240
XXXXXXXXXX XXXXXXXXXXXX XXXXXXXXXXXX XXXXXXXXXXXX XXXXXXXXXXXX XXXXXXXXXXXX 300
XXXXXXXXXX XXXXXXXXXXXX XXXXXXXXXXXX XGGGWGIPWC TLDPGSLQCA WLGKHXXXXX 360
XXXXXXXXXX XXXXXXXXXXXX XXXXXXXXXXXX XXXXXXXXXXXX XXXXXXXXXXXX XXXXXXXXXXXX 420
XXXXXXXXXX XXXXXXXXXXXX XXXXXXXXXXXX XXXXVVQCQD WEGVELCQWG G 471

SEQ ID NO: 55 moltype = AA length = 469
FEATURE Location/Qualifiers
source 1..469
mol_type = protein
organism = synthetic construct
VARIANT 228..329
note = This region may encompass one of the following
sequences: (GS)n where n is an integer from 1 to 20,
(GS)nGG where n is an integer from 1 to 20, (GS)nGG where
n is an integer from 1 to 15, (GGS)nGG where n is an
integer from 1 to 20, (GGS)nGG where n is an integer from
1 to 15, (GGGS)nGG where n is an integer from 1 to 20,
(GGGGS)nGG where n is an integer from 1 to 15, (GGGS)nGG
where n is an integer from 1 to 20, (GGGS)nGG where n is
an integer from 1 to 15, GSGSGSGSGS, GSGSGSGSGS,
GSGSGSGSGSGS, GSGSGSGSGSGSGS, GSGSGSGSGSGSGS,
GSGSGSGSGSGSGSGS, GSGSGSGSGSGSGSGS,
GSGSGSGSGSGSGSGSGS, GSGSGSGSGSGSGSGSGS,
GSGSGSGSGSGSGSGSGS,
GSGSGSGSGSGSGSGSGSGS, GSGSGSGSGSGS,
GSGSGSGSGSGSGG, GSGSGSGSGSGSGSGG, GSGSGSGSGSGSGSGG,
GSGSGSGSGSGSGSGSGG, GSGSGSGSGSGSGSGSGG,
GSGSGSGSGSGSGSGSGSGG, GSGSGSGSGSGSGSGSGSGG,
GSGSGSGSGSGSGSGSGSGG,

VARIANT 228..329
note = CONT. FROM ABOVE: GSGSGSGSGSGSGSGSGSGSGSGSGG,
GSGSGSGSGSGSGSGSGSGSGSGSGSGSGG, or (GS)n where n is an
integer from 5 to 15

VARIANT 354..453
note = This region may encompass one of the following
sequences: (P)n where n is an integer from 1 to 20, (P)n
where n is an integer from 5 to 15, (PA)n where n is an
integer from 1 to 20, (PA)n where n is an integer from 5
to 15, (P)nG where n is an integer from 1 to 20, (P)nG
where n is an integer from 5 to 15, (PA)nG where n is an
integer from 1 to 20, (PA)nG where n is an integer from 5
to 15, (P)nGG where n is an integer from 1 to 20, (P)nGG
where n is an integer from 5 to 15, (PA)nGG where n is an
integer from 1 to 20, (PA)nGG where n is an integer from 5
to 15, (G)n where n is an integer from 1 to 20, (G)n where
n is an integer from 1 to 15, (GS)n where n is an integer
from 1 to 20, (GS)n where n is an integer from 1 to 15,
(GGS)n where n is an integer from 1 to 20, (GGS)n where n
is an integer from 1 to 15, (GGGS)n where n is an integer
from 1 to 20, (GGGS)n where n is an integer from 1 to 15,

VARIANT 354..453
note = CONT. FROM ABOVE: (GGGS)n where n is an integer
from 1 to 20, (GGGS)n where n is an integer from 1 to
8, (GGGS)n where n is an integer from 1 to 10, (GGGS)n
where n is an integer from 1 to 5, GGGGS, GGGSGGGGS,
GGGSGGGSGGGGS, GGGSGGGSGGGSGGGGS,
GGGSGGGSGGGSGGGSGGGGS, (GGGS)nG where n is an integer
from 1 to 10, (GGGS)nG where n is an integer from 1 to 5,
GGGSG, GGGSGGGSG, GGGSGGGSGGGSG,
GGGSGGGSGGGSGGGSG, GGGSGGGSGGGSGGGSGGGSG,
(GGGGS)nGG where n is an integer from 1 to 10, (GGGS)nGG
where n is an integer from 1 to 5, GGGSGG, GGGSGGGSGG,
GGGSGGGSGGGSGG, GGGSGGGSGGGSGGGSGG, or
GGGSGGGSGGGSGGGSGGGSGG

SEQUENCE: 55

-continued

```

APPCPPCPAP EFEGGPSVFL FPPKPKDTLM ISRTPEVTCV VVDVSEQEDPE VQFNWYVDGV 60
EVHNAKTKPR EEQFNSTYRV VSVLTVLHQD WLNKKEYKCK VSNKGLGSSI EKTISKAKGQ 120
PREPQVYTLF PSQEEMTKNQ VSLTCLVKGF YPSDIAVEWE SNGQPENNYK TTPPVLDSGD 180
SFFLYSRLTV DKSRWQEGNV FSCSVMHEAL HNHYTQKSL SLSLGARTXXX XXXXXXXXXXXX 240
XXXXXXXXXX XXXXXXXXXXXX XXXXXXXXXXXX XXXXXXXXXXXX XXXXXXXXXXXX XXXXXXXXXXXX 300
XXXXXXXXXX XXXXXXXXXXXX XXXXXXXXXXXX GGGWIPWCTL DPGSLQCAWL GKXXXXXXXXXX 360
XXXXXXXXXX XXXXXXXXXXXX XXXXXXXXXXXX XXXXXXXXXXXX XXXXXXXXXXXX XXXXXXXXXXXX 420
XXXXXXXXXX XXXXXXXXXXXX XXXXXXXXXXXX XXXVVCQDWE GVELCWQGG 469
    
```

```

SEQ ID NO: 56          moltype = length =
SEQUENCE: 56
000
    
```

```

SEQ ID NO: 57          moltype = length =
SEQUENCE: 57
000
    
```

```

SEQ ID NO: 58          moltype = length =
SEQUENCE: 58
000
    
```

```

SEQ ID NO: 59          moltype = length =
SEQUENCE: 59
000
    
```

```

SEQ ID NO: 60          moltype = length =
SEQUENCE: 60
000
    
```

```

SEQ ID NO: 61          moltype = length =
SEQUENCE: 61
000
    
```

```

SEQ ID NO: 62          moltype = length =
SEQUENCE: 62
000
    
```

```

SEQ ID NO: 63          moltype = length =
SEQUENCE: 63
000
    
```

```

SEQ ID NO: 64          moltype = length =
SEQUENCE: 64
000
    
```

```

SEQ ID NO: 65          moltype = length =
SEQUENCE: 65
000
    
```

```

SEQ ID NO: 66          moltype = length =
SEQUENCE: 66
000
    
```

```

SEQ ID NO: 67          moltype = length =
SEQUENCE: 67
000
    
```

```

SEQ ID NO: 68          moltype = length =
SEQUENCE: 68
000
    
```

```

SEQ ID NO: 69          moltype = length =
SEQUENCE: 69
000
    
```

```

SEQ ID NO: 70          moltype = length =
SEQUENCE: 70
000
    
```

```

SEQ ID NO: 71          moltype = length =
SEQUENCE: 71
000
    
```

```

SEQ ID NO: 72          moltype = length =
SEQUENCE: 72
000
    
```

```

SEQ ID NO: 73          moltype = length =
SEQUENCE: 73
    
```

-continued

000

SEQ ID NO: 74 moltype = length =
SEQUENCE: 74
000

SEQ ID NO: 75 moltype = length =
SEQUENCE: 75
000

SEQ ID NO: 76 moltype = length =
SEQUENCE: 76
000

SEQ ID NO: 77 moltype = length =
SEQUENCE: 77
000

SEQ ID NO: 78 moltype = length =
SEQUENCE: 78
000

SEQ ID NO: 79 moltype = length =
SEQUENCE: 79
000

SEQ ID NO: 80 moltype = length =
SEQUENCE: 80
000

SEQ ID NO: 81 moltype = length =
SEQUENCE: 81
000

SEQ ID NO: 82 moltype = length =
SEQUENCE: 82
000

SEQ ID NO: 83 moltype = length =
SEQUENCE: 83
000

SEQ ID NO: 84 moltype = length =
SEQUENCE: 84
000

SEQ ID NO: 85 moltype = length =
SEQUENCE: 85
000

SEQ ID NO: 86 moltype = length =
SEQUENCE: 86
000

SEQ ID NO: 87 moltype = length =
SEQUENCE: 87
000

SEQ ID NO: 88 moltype = length =
SEQUENCE: 88
000

SEQ ID NO: 89 moltype = length =
SEQUENCE: 89
000

SEQ ID NO: 90 moltype = length =
SEQUENCE: 90
000

SEQ ID NO: 91 moltype = length =
SEQUENCE: 91
000

SEQ ID NO: 92 moltype = length =
SEQUENCE: 92
000

SEQ ID NO: 93 moltype = length =

-continued

```

SEQUENCE: 93
000

SEQ ID NO: 94      moltype =   length =
SEQUENCE: 94
000

SEQ ID NO: 95      moltype =   length =
SEQUENCE: 95
000

SEQ ID NO: 96      moltype =   length =
SEQUENCE: 96
000

SEQ ID NO: 97      moltype =   length =
SEQUENCE: 97
000

SEQ ID NO: 98      moltype =   length =
SEQUENCE: 98
000

SEQ ID NO: 99      moltype =   length =
SEQUENCE: 99
000

SEQ ID NO: 100     moltype =   length =
SEQUENCE: 100
000

SEQ ID NO: 101     moltype = AA length = 20
FEATURE           Location/Qualifiers
source           1..20
                 mol_type = protein
                 organism = synthetic construct
VARIANT          1..20
                 note = This sequence may encompass 1-20 residues
SEQUENCE: 101
PPPPPPPPPP PPPPPPPPP          20

SEQ ID NO: 102     moltype = AA length = 15
FEATURE           Location/Qualifiers
source           1..15
                 mol_type = protein
                 organism = synthetic construct
VARIANT          1..15
                 note = This sequence may encompass 5-15 residues
SEQUENCE: 102
PPPPPPPPPP PPPPP          15

SEQ ID NO: 103     moltype = AA length = 40
FEATURE           Location/Qualifiers
source           1..40
                 mol_type = protein
                 organism = synthetic construct
VARIANT          1..40
                 note = This sequence may encompass 1-20 PA repeating units
SEQUENCE: 103
PAPAPAPAPA PAPAPAPAPA PAPAPAPAPA PAPAPAPAPA          40

SEQ ID NO: 104     moltype = AA length = 30
FEATURE           Location/Qualifiers
source           1..30
                 mol_type = protein
                 organism = synthetic construct
VARIANT          1..30
                 note = This sequence may encompass 5-15 PA repeating units
SEQUENCE: 104
PAPAPAPAPA PAPAPAPAPA PAPAPAPAPA          30

SEQ ID NO: 105     moltype = AA length = 21
FEATURE           Location/Qualifiers
source           1..21
                 mol_type = protein
                 organism = synthetic construct
VARIANT          1..20
                 note = This region may encompass 1-20 residues
SEQUENCE: 105

```

-continued

PPPPPPPPPP	PPPPPPPPPP G	21
SEQ ID NO: 106	moltype = AA length = 16	
FEATURE	Location/Qualifiers	
source	1..16	
	mol_type = protein	
	organism = synthetic construct	
VARIANT	1..15	
	note = This region may encompass 5-15 residues	
SEQUENCE: 106		
PPPPPPPPPP	PPPPPG	16
SEQ ID NO: 107	moltype = AA length = 41	
FEATURE	Location/Qualifiers	
source	1..41	
	mol_type = protein	
	organism = synthetic construct	
VARIANT	1..40	
	note = This region may encompass 1-20 PA repeating units	
SEQUENCE: 107		
PAPAPAPAPA	PAPAPAPAPA PAPAPAPAPA PAPAPAPAPA G	41
SEQ ID NO: 108	moltype = AA length = 31	
FEATURE	Location/Qualifiers	
source	1..31	
	mol_type = protein	
	organism = synthetic construct	
VARIANT	1..30	
	note = This region may encompass 5-15 PA repeating units	
SEQUENCE: 108		
PAPAPAPAPA	PAPAPAPAPA PAPAPAPAPA G	31
SEQ ID NO: 109	moltype = AA length = 22	
FEATURE	Location/Qualifiers	
source	1..22	
	mol_type = protein	
	organism = synthetic construct	
VARIANT	1..20	
	note = This region may encompass 1-20 residues	
SEQUENCE: 109		
PPPPPPPPPP	PPPPPPPPPP GG	22
SEQ ID NO: 110	moltype = AA length = 17	
FEATURE	Location/Qualifiers	
source	1..17	
	mol_type = protein	
	organism = synthetic construct	
VARIANT	1..15	
	note = This region may encompass 5-15 residues	
SEQUENCE: 110		
PPPPPPPPPP	PPPPPGG	17
SEQ ID NO: 111	moltype = AA length = 42	
FEATURE	Location/Qualifiers	
source	1..42	
	mol_type = protein	
	organism = synthetic construct	
VARIANT	1..40	
	note = This region may encompass 1-20 PA repeating units	
SEQUENCE: 111		
PAPAPAPAPA	PAPAPAPAPA PAPAPAPAPA PAPAPAPAPA GG	42
SEQ ID NO: 112	moltype = AA length = 32	
FEATURE	Location/Qualifiers	
source	1..32	
	mol_type = protein	
	organism = synthetic construct	
VARIANT	1..30	
	note = This region may encompass 5-15 PA repeating units	
SEQUENCE: 112		
PAPAPAPAPA	PAPAPAPAPA PAPAPAPAPA GG	32
SEQ ID NO: 113	moltype = AA length = 20	
FEATURE	Location/Qualifiers	
source	1..20	
	mol_type = protein	
	organism = synthetic construct	
VARIANT	1..20	
	note = This sequence may encompass 1-20 residues	

-continued

SEQUENCE: 113
GGGGGGGGGG GGGGGGGGGG 20

SEQ ID NO: 114 moltype = AA length = 15
FEATURE Location/Qualifiers
source 1..15
 mol_type = protein
 organism = synthetic construct

VARIANT
 1..15
 note = This sequence may encompass 1-15 residues

SEQUENCE: 114
GGGGGGGGGG GGGGGG 15

SEQ ID NO: 115 moltype = AA length = 40
FEATURE Location/Qualifiers
source 1..40
 mol_type = protein
 organism = synthetic construct

VARIANT
 1..40
 note = This sequence may encompass 1-20 GS repeating units

SEQUENCE: 115
GSGSGSGSGS GSGSGSGSGS GSGSGSGSGS GSGSGSGSGS 40

SEQ ID NO: 116 moltype = AA length = 30
FEATURE Location/Qualifiers
source 1..30
 mol_type = protein
 organism = synthetic construct

VARIANT
 1..30
 note = This sequence may encompass 1-15 GS repeating units

SEQUENCE: 116
GSGSGSGSGS GSGSGSGSGS GSGSGSGSGS 30

SEQ ID NO: 117 moltype = AA length = 60
FEATURE Location/Qualifiers
source 1..60
 mol_type = protein
 organism = synthetic construct

VARIANT
 1..60
 note = This sequence may encompass 1-20 GGS repeating units

SEQUENCE: 117
GSGSGSGSGS GSGSGSGSGG SGGSGSGSGS GSGSGSGSGG SGGSGSGSGS 60

SEQ ID NO: 118 moltype = AA length = 45
FEATURE Location/Qualifiers
source 1..45
 mol_type = protein
 organism = synthetic construct

VARIANT
 1..45
 note = This sequence may encompass 1-15 GGS repeating units

SEQUENCE: 118
GSGSGSGSGS GSGSGSGSGG SGGSGSGSGS GSGSGSGSGG GSGGS 45

SEQ ID NO: 119 moltype = AA length = 80
FEATURE Location/Qualifiers
source 1..80
 mol_type = protein
 organism = synthetic construct

VARIANT
 1..80
 note = This sequence may encompass 1-20 GGS repeating units

SEQUENCE: 119
GGSGGGSGG GSGGGSGGGS GGGSGGGSGG GSGGGSGGGS GGGSGGGSGG GSGGGSGGGS 60
GGSGGGSGG GSGGGSGGGS 80

SEQ ID NO: 120 moltype = AA length = 60
FEATURE Location/Qualifiers
source 1..60
 mol_type = protein
 organism = synthetic construct

VARIANT
 1..60
 note = This sequence may encompass 1-15 GGS repeating units

SEQUENCE: 120
GGSGGGSGG GSGGGSGGGS GGGSGGGSGG GSGGGSGGGS GGGSGGGSGG GSGGGSGGGS 60

SEQ ID NO: 121 moltype = AA length = 100
FEATURE Location/Qualifiers
source 1..100
 mol_type = protein
 organism = synthetic construct

-continued

VARIANT 1..100
note = This sequence may encompass 1-20 GGGGS repeating units

SEQUENCE: 121
GGGSGGGGS GGGSGGGGS GGGSGGGGS GGGSGGGGS GGGSGGGGS GGGSGGGGS 60
GGGSGGGGS GGGSGGGGS GGGSGGGGS GGGSGGGGS 100

SEQ ID NO: 122 moltype = AA length = 40
FEATURE Location/Qualifiers
source 1..40
mol_type = protein
organism = synthetic construct

VARIANT 1..40
note = This sequence may encompass 1-8 GGGGS repeating units

SEQUENCE: 122
GGGSGGGGS GGGSGGGGS GGGSGGGGS GGGSGGGGS 40

SEQ ID NO: 123 moltype = AA length = 50
FEATURE Location/Qualifiers
source 1..50
mol_type = protein
organism = synthetic construct

VARIANT 1..50
note = This sequence may encompass 1-10 GGGGS repeating units

SEQUENCE: 123
GGGSGGGGS GGGSGGGGS GGGSGGGGS GGGSGGGGS GGGSGGGGS 50

SEQ ID NO: 124 moltype = AA length = 25
FEATURE Location/Qualifiers
source 1..25
mol_type = protein
organism = synthetic construct

VARIANT 1..25
note = This sequence may encompass 1-5 GGGGS repeating units

SEQUENCE: 124
GGGSGGGGS GGGSGGGGS GGGGS 25

SEQ ID NO: 125 moltype = AA length = 5
FEATURE Location/Qualifiers
source 1..5
mol_type = protein
organism = synthetic construct

SEQUENCE: 125
GGGS 5

SEQ ID NO: 126 moltype = AA length = 10
FEATURE Location/Qualifiers
source 1..10
mol_type = protein
organism = synthetic construct

SEQUENCE: 126
GGGSGGGGS 10

SEQ ID NO: 127 moltype = AA length = 15
FEATURE Location/Qualifiers
source 1..15
mol_type = protein
organism = synthetic construct

SEQUENCE: 127
GGGSGGGGS GGGGS 15

SEQ ID NO: 128 moltype = AA length = 20
FEATURE Location/Qualifiers
source 1..20
mol_type = protein
organism = synthetic construct

SEQUENCE: 128
GGGSGGGGS GGGSGGGGS 20

SEQ ID NO: 129 moltype = AA length = 25
FEATURE Location/Qualifiers
source 1..25
mol_type = protein
organism = synthetic construct

SEQUENCE: 129
GGGSGGGGS GGGSGGGGS GGGGS 25

SEQ ID NO: 130 moltype = AA length = 51

-continued

FEATURE	Location/Qualifiers	
source	1..51	
	mol_type = protein	
	organism = synthetic construct	
VARIANT	1..50	
	note = This region may encompass 1-10 GGGGS repeating units	
SEQUENCE: 130		
GGGSGGGGS GGGSGGGGS GGGSGGGGS GGGSGGGGS GGGSGGGGS G		51
SEQ ID NO: 131	moltype = AA length = 26	
FEATURE	Location/Qualifiers	
source	1..26	
	mol_type = protein	
	organism = synthetic construct	
VARIANT	1..25	
	note = This region may encompass 1-5 GGGGS repeating units	
SEQUENCE: 131		
GGGSGGGGS GGGSGGGGS GGGSGG		26
SEQ ID NO: 132	moltype = AA length = 6	
FEATURE	Location/Qualifiers	
source	1..6	
	mol_type = protein	
	organism = synthetic construct	
SEQUENCE: 132		
GGGSGG		6
SEQ ID NO: 133	moltype = AA length = 11	
FEATURE	Location/Qualifiers	
source	1..11	
	mol_type = protein	
	organism = synthetic construct	
SEQUENCE: 133		
GGGSGGGGS G		11
SEQ ID NO: 134	moltype = AA length = 16	
FEATURE	Location/Qualifiers	
source	1..16	
	mol_type = protein	
	organism = synthetic construct	
SEQUENCE: 134		
GGGSGGGGS GGGSGG		16
SEQ ID NO: 135	moltype = AA length = 21	
FEATURE	Location/Qualifiers	
source	1..21	
	mol_type = protein	
	organism = synthetic construct	
SEQUENCE: 135		
GGGSGGGGS GGGSGGGGS G		21
SEQ ID NO: 136	moltype = AA length = 26	
FEATURE	Location/Qualifiers	
source	1..26	
	mol_type = protein	
	organism = synthetic construct	
SEQUENCE: 136		
GGGSGGGGS GGGSGGGGS GGGSGG		26
SEQ ID NO: 137	moltype = AA length = 52	
FEATURE	Location/Qualifiers	
source	1..52	
	mol_type = protein	
	organism = synthetic construct	
VARIANT	1..50	
	note = This region may encompass 1-10 GGGGS repeating units	
SEQUENCE: 137		
GGGSGGGGS GGGSGGGGS GGGSGGGGS GGGSGGGGS GGGSGGGGS GG		52
SEQ ID NO: 138	moltype = AA length = 27	
FEATURE	Location/Qualifiers	
source	1..27	
	mol_type = protein	
	organism = synthetic construct	
VARIANT	1..25	
	note = This region may encompass 1-5 GGGGS repeating units	
SEQUENCE: 138		
GGGSGGGGS GGGSGGGGS GGGSGG		27

-continued

SEQ ID NO: 139	moltype = AA length = 7	
FEATURE	Location/Qualifiers	
source	1..7	
	mol_type = protein	
	organism = synthetic construct	
SEQUENCE: 139		7
GGGSGG		
SEQ ID NO: 140	moltype = AA length = 12	
FEATURE	Location/Qualifiers	
source	1..12	
	mol_type = protein	
	organism = synthetic construct	
SEQUENCE: 140		12
GGGSGGGGS GG		
SEQ ID NO: 141	moltype = AA length = 17	
FEATURE	Location/Qualifiers	
source	1..17	
	mol_type = protein	
	organism = synthetic construct	
SEQUENCE: 141		17
GGGSGGGGS GGGSGG		
SEQ ID NO: 142	moltype = AA length = 22	
FEATURE	Location/Qualifiers	
source	1..22	
	mol_type = protein	
	organism = synthetic construct	
SEQUENCE: 142		22
GGGSGGGGS GGGSGGGGS GG		
SEQ ID NO: 143	moltype = AA length = 27	
FEATURE	Location/Qualifiers	
source	1..27	
	mol_type = protein	
	organism = synthetic construct	
SEQUENCE: 143		27
GGGSGGGGS GGGSGGGGS GGGSGG		
SEQ ID NO: 144	moltype = length =	
SEQUENCE: 144		
000		
SEQ ID NO: 145	moltype = length =	
SEQUENCE: 145		
000		
SEQ ID NO: 146	moltype = length =	
SEQUENCE: 146		
000		
SEQ ID NO: 147	moltype = length =	
SEQUENCE: 147		
000		
SEQ ID NO: 148	moltype = length =	
SEQUENCE: 148		
000		
SEQ ID NO: 149	moltype = length =	
SEQUENCE: 149		
000		
SEQ ID NO: 150	moltype = AA length = 42	
FEATURE	Location/Qualifiers	
source	1..42	
	mol_type = protein	
	organism = synthetic construct	
VARIANT	1..40	
	note = This region may encompass 1-20 GS repeating units	
SEQUENCE: 150		42
GSGSGSGSGS GSGSGSGSGS GSGSGSGSGS GSGSGSGSGS GG		
SEQ ID NO: 151	moltype = AA length = 32	
FEATURE	Location/Qualifiers	
source	1..32	
	mol_type = protein	
	organism = synthetic construct	

-continued

VARIANT 1..30
note = This region may encompass 1-15 GS repeating units

SEQUENCE: 151
GSGSGSGSGS GSGSGSGSGS GSGSGSGSGS GG 32

SEQ ID NO: 152 moltype = AA length = 62
FEATURE Location/Qualifiers
source 1..62
mol_type = protein
organism = synthetic construct

VARIANT 1..60
note = This region may encompass 1-20 GGS repeating units

SEQUENCE: 152
GSGSGSGSGS GSGSGSGSGS GSGSGSGSGS GSGSGSGSGS GSGSGSGSGS GSGSGSGSGS 60
GG 62

SEQ ID NO: 153 moltype = AA length = 47
FEATURE Location/Qualifiers
source 1..47
mol_type = protein
organism = synthetic construct

VARIANT 1..45
note = This region may encompass 1-15 GGS repeating units

SEQUENCE: 153
GSGSGSGSGS GSGSGSGSGS GSGSGSGSGS GSGSGSGSGS GSGSGSG 47

SEQ ID NO: 154 moltype = AA length = 82
FEATURE Location/Qualifiers
source 1..82
mol_type = protein
organism = synthetic construct

VARIANT 1..80
note = This region may encompass 1-20 GGS repeating units

SEQUENCE: 154
GSGSGSGSGS GSGSGSGSGS GSGSGSGSGS GSGSGSGSGS GSGSGSGSGS GSGSGSGSGS 60
GSGSGSGSGS GSGSGSGSGS GG 82

SEQ ID NO: 155 moltype = AA length = 62
FEATURE Location/Qualifiers
source 1..62
mol_type = protein
organism = synthetic construct

VARIANT 1..60
note = This region may encompass 1-15 GGS repeating units

SEQUENCE: 155
GSGSGSGSGS GSGSGSGSGS GSGSGSGSGS GSGSGSGSGS GSGSGSGSGS GSGSGSGSGS 60
GG 62

SEQ ID NO: 156 moltype = AA length = 102
FEATURE Location/Qualifiers
source 1..102
mol_type = protein
organism = synthetic construct

VARIANT 1..100
note = This region may encompass 1-20 GGS repeating units

SEQUENCE: 156
GSGSGSGSGS GSGSGSGSGS GSGSGSGSGS GSGSGSGSGS GSGSGSGSGS GSGSGSGSGS 60
GSGSGSGSGS GSGSGSGSGS GSGSGSGSGS GSGSGSGSGS GG 102

SEQ ID NO: 157 moltype = AA length = 77
FEATURE Location/Qualifiers
source 1..77
mol_type = protein
organism = synthetic construct

VARIANT 1..75
note = This region may encompass 1-15 GGS repeating units

SEQUENCE: 157
GSGSGSGSGS GSGSGSGSGS GSGSGSGSGS GSGSGSGSGS GSGSGSGSGS GSGSGSGSGS 60
GSGSGSGSGS GSGSGSG 77

SEQ ID NO: 158 moltype = AA length = 10
FEATURE Location/Qualifiers
source 1..10
mol_type = protein
organism = synthetic construct

SEQUENCE: 158
GSGSGSGSGS 10

SEQ ID NO: 159 moltype = AA length = 12

-continued

FEATURE	Location/Qualifiers	
source	1..12	
	mol_type = protein	
	organism = synthetic construct	
SEQUENCE: 159		
GSGSGSGSGS GS		12
SEQ ID NO: 160	moltype = AA length = 14	
FEATURE	Location/Qualifiers	
source	1..14	
	mol_type = protein	
	organism = synthetic construct	
SEQUENCE: 160		
GSGSGSGSGS GSGS		14
SEQ ID NO: 161	moltype = AA length = 16	
FEATURE	Location/Qualifiers	
source	1..16	
	mol_type = protein	
	organism = synthetic construct	
SEQUENCE: 161		
GSGSGSGSGS GSGSGS		16
SEQ ID NO: 162	moltype = AA length = 18	
FEATURE	Location/Qualifiers	
source	1..18	
	mol_type = protein	
	organism = synthetic construct	
SEQUENCE: 162		
GSGSGSGSGS GSGSGSGS		18
SEQ ID NO: 163	moltype = AA length = 20	
FEATURE	Location/Qualifiers	
source	1..20	
	mol_type = protein	
	organism = synthetic construct	
SEQUENCE: 163		
GSGSGSGSGS GSGSGSGSGS		20
SEQ ID NO: 164	moltype = AA length = 22	
FEATURE	Location/Qualifiers	
source	1..22	
	mol_type = protein	
	organism = synthetic construct	
SEQUENCE: 164		
GSGSGSGSGS GSGSGSGSGS GS		22
SEQ ID NO: 165	moltype = AA length = 24	
FEATURE	Location/Qualifiers	
source	1..24	
	mol_type = protein	
	organism = synthetic construct	
SEQUENCE: 165		
GSGSGSGSGS GSGSGSGSGS GSGS		24
SEQ ID NO: 166	moltype = AA length = 26	
FEATURE	Location/Qualifiers	
source	1..26	
	mol_type = protein	
	organism = synthetic construct	
SEQUENCE: 166		
GSGSGSGSGS GSGSGSGSGS GSGSGS		26
SEQ ID NO: 167	moltype = AA length = 28	
FEATURE	Location/Qualifiers	
source	1..28	
	mol_type = protein	
	organism = synthetic construct	
SEQUENCE: 167		
GSGSGSGSGS GSGSGSGSGS GSGSGSGS		28
SEQ ID NO: 168	moltype = AA length = 30	
FEATURE	Location/Qualifiers	
source	1..30	
	mol_type = protein	
	organism = synthetic construct	
SEQUENCE: 168		
GSGSGSGSGS GSGSGSGSGS GSGSGSGSGS		30

-continued

SEQ ID NO: 169	moltype = AA length = 12	
FEATURE	Location/Qualifiers	
source	1..12	
	mol_type = protein	
	organism = synthetic construct	
SEQUENCE: 169		12
GSGSGSGSGS GG		
SEQ ID NO: 170	moltype = AA length = 14	
FEATURE	Location/Qualifiers	
source	1..14	
	mol_type = protein	
	organism = synthetic construct	
SEQUENCE: 170		14
GSGSGSGSGS GSGG		
SEQ ID NO: 171	moltype = AA length = 16	
FEATURE	Location/Qualifiers	
source	1..16	
	mol_type = protein	
	organism = synthetic construct	
SEQUENCE: 171		16
GSGSGSGSGS GSGSGG		
SEQ ID NO: 172	moltype = AA length = 18	
FEATURE	Location/Qualifiers	
source	1..18	
	mol_type = protein	
	organism = synthetic construct	
SEQUENCE: 172		18
GSGSGSGSGS GSGSGSGG		
SEQ ID NO: 173	moltype = AA length = 20	
FEATURE	Location/Qualifiers	
source	1..20	
	mol_type = protein	
	organism = synthetic construct	
SEQUENCE: 173		20
GSGSGSGSGS GSGSGSGSGG		
SEQ ID NO: 174	moltype = AA length = 22	
FEATURE	Location/Qualifiers	
source	1..22	
	mol_type = protein	
	organism = synthetic construct	
SEQUENCE: 174		22
GSGSGSGSGS GSGSGSGSGS GG		
SEQ ID NO: 175	moltype = AA length = 24	
FEATURE	Location/Qualifiers	
source	1..24	
	mol_type = protein	
	organism = synthetic construct	
SEQUENCE: 175		24
GSGSGSGSGS GSGSGSGSGS GSGG		
SEQ ID NO: 176	moltype = AA length = 26	
FEATURE	Location/Qualifiers	
source	1..26	
	mol_type = protein	
	organism = synthetic construct	
SEQUENCE: 176		26
GSGSGSGSGS GSGSGSGSGS GSGSGG		
SEQ ID NO: 177	moltype = AA length = 28	
FEATURE	Location/Qualifiers	
source	1..28	
	mol_type = protein	
	organism = synthetic construct	
SEQUENCE: 177		28
GSGSGSGSGS GSGSGSGSGS GSGSGSGG		
SEQ ID NO: 178	moltype = AA length = 30	
FEATURE	Location/Qualifiers	
source	1..30	
	mol_type = protein	
	organism = synthetic construct	
SEQUENCE: 178		30
GSGSGSGSGS GSGSGSGSGS GSGSGSGSGG		

-continued

SEQ ID NO: 179	moltype = AA	length = 32	
FEATURE	Location/Qualifiers		
source	1..32		
	mol_type = protein		
	organism = synthetic construct		
SEQUENCE: 179			
GSGSGSGSGS	GSGSGSGSGS	GSGSGSGSGS	GG
			32
SEQ ID NO: 180	moltype =	length =	
SEQUENCE: 180			
000			
SEQ ID NO: 181	moltype =	length =	
SEQUENCE: 181			
000			
SEQ ID NO: 182	moltype =	length =	
SEQUENCE: 182			
000			
SEQ ID NO: 183	moltype =	length =	
SEQUENCE: 183			
000			
SEQ ID NO: 184	moltype =	length =	
SEQUENCE: 184			
000			
SEQ ID NO: 185	moltype =	length =	
SEQUENCE: 185			
000			
SEQ ID NO: 186	moltype =	length =	
SEQUENCE: 186			
000			
SEQ ID NO: 187	moltype =	length =	
SEQUENCE: 187			
000			
SEQ ID NO: 188	moltype =	length =	
SEQUENCE: 188			
000			
SEQ ID NO: 189	moltype =	length =	
SEQUENCE: 189			
000			
SEQ ID NO: 190	moltype =	length =	
SEQUENCE: 190			
000			
SEQ ID NO: 191	moltype =	length =	
SEQUENCE: 191			
000			
SEQ ID NO: 192	moltype =	length =	
SEQUENCE: 192			
000			
SEQ ID NO: 193	moltype =	length =	
SEQUENCE: 193			
000			
SEQ ID NO: 194	moltype =	length =	
SEQUENCE: 194			
000			
SEQ ID NO: 195	moltype =	length =	
SEQUENCE: 195			
000			
SEQ ID NO: 196	moltype =	length =	
SEQUENCE: 196			
000			
SEQ ID NO: 197	moltype =	length =	
SEQUENCE: 197			

-continued

000

SEQ ID NO: 198 moltype = length =
 SEQUENCE: 198
 000

SEQ ID NO: 199 moltype = length =
 SEQUENCE: 199
 000

SEQ ID NO: 200 moltype = length =
 SEQUENCE: 200
 000

SEQ ID NO: 201 moltype = AA length = 20
 FEATURE Location/Qualifiers
 source 1..20
 mol_type = protein
 organism = synthetic construct

SEQUENCE: 201
 YPCWLARVGE LCDLDSGDVH

20

SEQ ID NO: 202 moltype = AA length = 20
 FEATURE Location/Qualifiers
 source 1..20
 mol_type = protein
 organism = synthetic construct

SEQUENCE: 202
 APCWLARVGE LCDLDSGDVH

20

SEQ ID NO: 203 moltype = AA length = 20
 FEATURE Location/Qualifiers
 source 1..20
 mol_type = protein
 organism = synthetic construct

SEQUENCE: 203
 APCALARVGE LCDLDSGDVH

20

SEQ ID NO: 204 moltype = AA length = 20
 FEATURE Location/Qualifiers
 source 1..20
 mol_type = protein
 organism = synthetic construct

SEQUENCE: 204
 APCALAAVGE LCDLDSGDVH

20

SEQ ID NO: 205 moltype = AA length = 20
 FEATURE Location/Qualifiers
 source 1..20
 mol_type = protein
 organism = synthetic construct

SEQUENCE: 205
 APCALAAVGA LCDLDSGDVH

20

SEQ ID NO: 206 moltype = AA length = 20
 FEATURE Location/Qualifiers
 source 1..20
 mol_type = protein
 organism = synthetic construct

SEQUENCE: 206
 APCALAAVGA LCDLASGDVH

20

SEQ ID NO: 207 moltype = AA length = 20
 FEATURE Location/Qualifiers
 source 1..20
 mol_type = protein
 organism = synthetic construct

SEQUENCE: 207
 APCALAAVGA LCDLAAGDVH

20

SEQ ID NO: 208 moltype = length =
 SEQUENCE: 208
 000

SEQ ID NO: 209 moltype = length =
 SEQUENCE: 209
 000

SEQ ID NO: 210 moltype = length =

-continued

SEQUENCE: 210 000		
SEQ ID NO: 211 FEATURE source	moltype = AA length = 14 Location/Qualifiers 1..14 mol_type = protein organism = synthetic construct	
SEQUENCE: 211 YWCWMAQVGE LCDL		14
SEQ ID NO: 212 FEATURE source	moltype = AA length = 14 Location/Qualifiers 1..14 mol_type = protein organism = synthetic construct	
SEQUENCE: 212 YHCWMAQVGE LCDL		14
SEQ ID NO: 213 FEATURE source	moltype = AA length = 14 Location/Qualifiers 1..14 mol_type = protein organism = synthetic construct	
SEQUENCE: 213 YHCWMAQVGE LCDL		14
SEQ ID NO: 214 FEATURE source	moltype = AA length = 14 Location/Qualifiers 1..14 mol_type = protein organism = synthetic construct	
SEQUENCE: 214 YHCWMAQVGE LCDL		14
SEQ ID NO: 215 FEATURE source	moltype = AA length = 14 Location/Qualifiers 1..14 mol_type = protein organism = synthetic construct	
SEQUENCE: 215 YHCWMAQVGE LCEL		14
SEQ ID NO: 216 FEATURE source	moltype = AA length = 14 Location/Qualifiers 1..14 mol_type = protein organism = synthetic construct	
SEQUENCE: 216 YHCWMAQVGE LCEM		14
SEQ ID NO: 217 SEQUENCE: 217 000	moltype = length =	
SEQ ID NO: 218 SEQUENCE: 218 000	moltype = length =	
SEQ ID NO: 219 SEQUENCE: 219 000	moltype = length =	
SEQ ID NO: 220 FEATURE source	moltype = AA length = 14 Location/Qualifiers 1..14 mol_type = protein organism = synthetic construct	
SEQUENCE: 220 KYCGFAQLGE LCVL		14
SEQ ID NO: 221 FEATURE source	moltype = AA length = 15 Location/Qualifiers 1..15 mol_type = protein organism = synthetic construct	
SEQUENCE: 221 GKYCGFAQLG ELCVL		15

-continued

SEQ ID NO: 222	moltype = AA length = 16	
FEATURE	Location/Qualifiers	
source	1..16	
	mol_type = protein	
	organism = synthetic construct	
SEQUENCE: 222		
GGKYCGFAQL GELCVL		16
SEQ ID NO: 223	moltype = AA length = 17	
FEATURE	Location/Qualifiers	
source	1..17	
	mol_type = protein	
	organism = synthetic construct	
SEQUENCE: 223		
GGGKYCGFAQ LGELCVL		17
SEQ ID NO: 224	moltype = AA length = 15	
FEATURE	Location/Qualifiers	
source	1..15	
	mol_type = protein	
	organism = synthetic construct	
SEQUENCE: 224		
KYCGFAQLGE LCVLG		15
SEQ ID NO: 225	moltype = AA length = 16	
FEATURE	Location/Qualifiers	
source	1..16	
	mol_type = protein	
	organism = synthetic construct	
SEQUENCE: 225		
KYCGFAQLGE LCVLGG		16
SEQ ID NO: 226	moltype = AA length = 17	
FEATURE	Location/Qualifiers	
source	1..17	
	mol_type = protein	
	organism = synthetic construct	
SEQUENCE: 226		
KYCGFAQLGE LCVLGGG		17
SEQ ID NO: 227	moltype = AA length = 16	
FEATURE	Location/Qualifiers	
source	1..16	
	mol_type = protein	
	organism = synthetic construct	
SEQUENCE: 227		
GKYCGFAQLG ELCVLG		16
SEQ ID NO: 228	moltype = AA length = 17	
FEATURE	Location/Qualifiers	
source	1..17	
	mol_type = protein	
	organism = synthetic construct	
SEQUENCE: 228		
GGKYCGFAQL GELCVLG		17
SEQ ID NO: 229	moltype = length =	
SEQUENCE: 229		
000		
SEQ ID NO: 230	moltype = length =	
SEQUENCE: 230		
000		
SEQ ID NO: 231	moltype = length =	
SEQUENCE: 231		
000		
SEQ ID NO: 232	moltype = length =	
SEQUENCE: 232		
000		
SEQ ID NO: 233	moltype = length =	
SEQUENCE: 233		
000		
SEQ ID NO: 234	moltype = length =	
SEQUENCE: 234		
000		

-continued

SEQ ID NO: 235 SEQUENCE: 235 000	moltype = length =
SEQ ID NO: 236 SEQUENCE: 236 000	moltype = length =
SEQ ID NO: 237 SEQUENCE: 237 000	moltype = length =
SEQ ID NO: 238 SEQUENCE: 238 000	moltype = length =
SEQ ID NO: 239 SEQUENCE: 239 000	moltype = length =
SEQ ID NO: 240 SEQUENCE: 240 000	moltype = length =
SEQ ID NO: 241 SEQUENCE: 241 000	moltype = length =
SEQ ID NO: 242 SEQUENCE: 242 000	moltype = length =
SEQ ID NO: 243 SEQUENCE: 243 000	moltype = length =
SEQ ID NO: 244 SEQUENCE: 244 000	moltype = length =
SEQ ID NO: 245 SEQUENCE: 245 000	moltype = length =
SEQ ID NO: 246 SEQUENCE: 246 000	moltype = length =
SEQ ID NO: 247 SEQUENCE: 247 000	moltype = length =
SEQ ID NO: 248 SEQUENCE: 248 000	moltype = length =
SEQ ID NO: 249 SEQUENCE: 249 000	moltype = length =
SEQ ID NO: 250 SEQUENCE: 250 000	moltype = length =
SEQ ID NO: 251 SEQUENCE: 251 000	moltype = length =
SEQ ID NO: 252 SEQUENCE: 252 000	moltype = length =
SEQ ID NO: 253 SEQUENCE: 253 000	moltype = length =
SEQ ID NO: 254 SEQUENCE: 254	moltype = length =

-continued

000

SEQ ID NO: 255 moltype = length =
SEQUENCE: 255
000

SEQ ID NO: 256 moltype = length =
SEQUENCE: 256
000

SEQ ID NO: 257 moltype = length =
SEQUENCE: 257
000

SEQ ID NO: 258 moltype = length =
SEQUENCE: 258
000

SEQ ID NO: 259 moltype = length =
SEQUENCE: 259
000

SEQ ID NO: 260 moltype = length =
SEQUENCE: 260
000

SEQ ID NO: 261 moltype = length =
SEQUENCE: 261
000

SEQ ID NO: 262 moltype = length =
SEQUENCE: 262
000

SEQ ID NO: 263 moltype = length =
SEQUENCE: 263
000

SEQ ID NO: 264 moltype = length =
SEQUENCE: 264
000

SEQ ID NO: 265 moltype = length =
SEQUENCE: 265
000

SEQ ID NO: 266 moltype = length =
SEQUENCE: 266
000

SEQ ID NO: 267 moltype = length =
SEQUENCE: 267
000

SEQ ID NO: 268 moltype = length =
SEQUENCE: 268
000

SEQ ID NO: 269 moltype = length =
SEQUENCE: 269
000

SEQ ID NO: 270 moltype = length =
SEQUENCE: 270
000

SEQ ID NO: 271 moltype = length =
SEQUENCE: 271
000

SEQ ID NO: 272 moltype = length =
SEQUENCE: 272
000

SEQ ID NO: 273 moltype = length =
SEQUENCE: 273
000

SEQ ID NO: 274 moltype = length =

-continued

SEQUENCE: 274 000		
SEQ ID NO: 275 SEQUENCE: 275 000	moltype =	length =
SEQ ID NO: 276 SEQUENCE: 276 000	moltype =	length =
SEQ ID NO: 277 SEQUENCE: 277 000	moltype =	length =
SEQ ID NO: 278 SEQUENCE: 278 000	moltype =	length =
SEQ ID NO: 279 SEQUENCE: 279 000	moltype =	length =
SEQ ID NO: 280 SEQUENCE: 280 000	moltype =	length =
SEQ ID NO: 281 SEQUENCE: 281 000	moltype =	length =
SEQ ID NO: 282 SEQUENCE: 282 000	moltype =	length =
SEQ ID NO: 283 SEQUENCE: 283 000	moltype =	length =
SEQ ID NO: 284 SEQUENCE: 284 000	moltype =	length =
SEQ ID NO: 285 SEQUENCE: 285 000	moltype =	length =
SEQ ID NO: 286 SEQUENCE: 286 000	moltype =	length =
SEQ ID NO: 287 SEQUENCE: 287 000	moltype =	length =
SEQ ID NO: 288 SEQUENCE: 288 000	moltype =	length =
SEQ ID NO: 289 SEQUENCE: 289 000	moltype =	length =
SEQ ID NO: 290 SEQUENCE: 290 000	moltype =	length =
SEQ ID NO: 291 SEQUENCE: 291 000	moltype =	length =
SEQ ID NO: 292 SEQUENCE: 292 000	moltype =	length =
SEQ ID NO: 293 SEQUENCE: 293 000	moltype =	length =

-continued

SEQ ID NO: 294 SEQUENCE: 294 000	moltype = length =	
SEQ ID NO: 295 SEQUENCE: 295 000	moltype = length =	
SEQ ID NO: 296 SEQUENCE: 296 000	moltype = length =	
SEQ ID NO: 297 SEQUENCE: 297 000	moltype = length =	
SEQ ID NO: 298 SEQUENCE: 298 000	moltype = length =	
SEQ ID NO: 299 SEQUENCE: 299 000	moltype = length =	
SEQ ID NO: 300 FEATURE source	moltype = AA length = 24 Location/Qualifiers 1..24 mol_type = protein organism = synthetic construct	
SEQUENCE: 300 VHRIPWCTLD PGGLQCAWLR QMGG		24
SEQ ID NO: 301 FEATURE source	moltype = AA length = 30 Location/Qualifiers 1..30 mol_type = protein organism = synthetic construct	
VARIANT	1..30 note = This sequence may encompass 5-15 GS repeating units	
SEQUENCE: 301 GSGSGSGSGS GSGSGSGSGS GSGSGSGSGS		30
SEQ ID NO: 302 FEATURE source	moltype = AA length = 32 Location/Qualifiers 1..32 mol_type = protein organism = synthetic construct	
VARIANT	1..30 note = This region may encompass 5-15 GS repeating units	
SEQUENCE: 302 GSGSGSGSGS GSGSGSGSGS GSGSGSGSGS GG		32

45

What is claimed is:

1. An IL-7R α yc ligand comprising:
 - an IL-7R α ligand comprising an amino acid sequence of SEQ ID NO: 1 or an amino acid sequence having greater than 70% sequence similarity to SEQ ID NO: 1; and
 - an Ryc ligand comprising an amino acid sequence of SEQ ID NO: 11 or an amino acid sequence having greater than 70% sequence similarity to SEQ ID NO: 11.
2. The IL-7R α yc ligand of claim 1, wherein the IL-7R α yc ligand comprises:
 - an IL-7R α ligand comprising an amino acid sequence of SEQ ID NO: 1 and
 - an Ryc ligand comprising an amino acid sequence of SEQ ID NO: 11.
3. The IL-7R α yc ligand of claim 1, wherein the IL-7R α yc ligand comprises:
 - an IL-7R α ligand comprising an amino acid sequence having greater than 70% sequence similarity to SEQ ID NO: 1; and
 - an Ryc ligand comprising an amino acid sequence having greater than 70% sequence similarity to SEQ ID NO: 11.
4. The IL-7R α yc ligand of claim 1, wherein the IL-7R α yc ligand comprises:
 - an IL-7R α ligand comprising an amino acid sequence based on SEQ ID NO: 1 and having from 1 to 5 amino acid substitutions; and
 - an Ryc ligand comprising an amino acid sequence based on SEQ ID NO: 11 and having from 1 to 5 amino acid substitutions.
5. The IL-7R α yc ligand of claim 1, wherein each of the IL-7R α ligand and the Ryc ligand independently comprises from 1 to 6 glycines (G) on the N-terminus, on the C-terminus, or on both the N-terminus and the C-terminus.
6. The IL-7R α yc ligand of claim 1, wherein the IL-7R α ligand and the Ryc ligand are bound together through a ligand linker.
7. The IL-7R α yc ligand of claim 6, wherein the ligand linker comprises an amino acid sequence selected from any one of SEQ ID NO: 113-136.

8. The IL-7R $\alpha\gamma\epsilon$ ligand of claim 1, wherein the IL-7R $\alpha\gamma\epsilon$ ligand comprises:

- an amino acid sequence of any one of SEQ ID NO: 21-26
or an amino acid sequence having greater than 70%
sequence similarity to any one of SEQ ID NO: 21-26: 5
WGIPWCTLDPGSLQCAWLKGKX¹-
VVCQDWEGVELCWQ (SEQ ID NO: 21)
GWGIPWCTLDPGSLQCAWLKGKX¹-
VVCQDWEGVELCWQ (SEQ ID NO: 22)
WGIPWCTLDPGSLQCAWLKGKX¹-
VVCQDWEGVELCWQGG (SEQ ID NO: 23) 10
GWGIPWCTLDPGSLQCAWLKGKX¹-
VVCQDWEGVELCWQGG (SEQ ID NO: 24)
GGWIPWCTLDPGSLQCAWLKGKX¹-
VVCQDWEGVELCWQGG (SEQ ID NO: 25) 15
GGWIPWCTLDPGSLQCAWLKGKX¹-
VVCQDWEGVELCWQGG (SEQ ID NO: 26);

and wherein X¹ is selected from an amino acid sequence of any one of SEQ ID NO: 101-143.

9. The IL-7R $\alpha\gamma\epsilon$ ligand of claim 8, wherein X¹ is selected from of any one of SEQ ID NO: 137-143. 20

10. The IL-7R $\alpha\gamma\epsilon$ ligand of claim 8, wherein X¹ has an amino acid sequence of SEQ ID NO: 139.

11. The IL-7R $\alpha\gamma\epsilon$ ligand of claim 1, wherein the IL-7R $\alpha\gamma\epsilon$ ligand comprises an amino acid sequence of any 25 one of SEQ ID NO: 27-32, or an amino acid sequence having greater than 70% sequence similarity to any one of SEQ ID NO: 27-32.

12. The IL-7R $\alpha\gamma\epsilon$ ligand of claim 1, wherein the IL-7R $\alpha\gamma\epsilon$ ligand comprises an amino acid sequence of SEQ 30 ID NO: 32 or an amino acid sequence having greater than 70% sequence similarity to SEQ ID NO: 32.

13. An IL-7R $\alpha\gamma\epsilon$ IgG-Fc fusion fragment comprising the IL-7R $\alpha\gamma\epsilon$ ligand of claim 1 bound to an IgG-Fc fragment.

14. The IL-7R $\alpha\gamma\epsilon$ IgG-Fc fusion fragment of claim 13, 35 wherein the IgG-Fc fragment is selected from an IgG1-Fc fragment, an IgG2-Fc fragment, and an IgG4-Fc fragment.

15. The IL-7R $\alpha\gamma\epsilon$ IgG-Fc fusion fragment of claim 13, wherein the IgG-Fc fragment is an IgG2-Fc fragment.

16. The IL-7R $\alpha\gamma\epsilon$ IgG-Fc fusion fragment of claim 13, 40 wherein the IL-7R $\alpha\gamma\epsilon$ ligand is bound to the IgG-Fc fragment through an IgG-Fc linker.

17. The IL-7R $\alpha\gamma\epsilon$ IgG-Fc fusion fragment of claim 16, wherein the IgG-Fc linker comprises an amino acid 45 sequence of any one of SEQ ID NO: 150-179.

18. The IL-7R $\alpha\gamma\epsilon$ IgG-Fc fusion fragment of claim 16, wherein the IgG-Fc linker comprises an amino acid sequence of SEQ ID NO: 163.

19. The IL-7R $\alpha\gamma\epsilon$ IgG-Fc fusion fragment of claim 13, wherein the IL-7R $\alpha\gamma\epsilon$ IgG-Fc fusion fragment comprises an amino acid sequence having greater than 70% sequence similarity to any one of SEQ ID NO: 44-55.

20. The IL-7R $\alpha\gamma\epsilon$ IgG-Fc fusion fragment of claim 13, wherein the IL-7R $\alpha\gamma\epsilon$ IgG-Fc fusion fragment comprises an amino acid sequence of any one of SEQ ID NO: 44-55.

21. The IL-7R $\alpha\gamma\epsilon$ IgG-Fc fusion fragment of claim 13, wherein the IL-7R $\alpha\gamma\epsilon$ IgG-Fc fusion fragment comprises an amino acid sequence having greater than 70% sequence similarity to SEQ ID NO: 45. 10

22. The IL-7R $\alpha\gamma\epsilon$ IgG-Fc fusion fragment of claim 13, wherein the IL-7R $\alpha\gamma\epsilon$ IgG-Fc fusion fragment comprises an amino acid sequence having SEQ ID NO: 45. 15

23. An IL-7R $\alpha\gamma\epsilon$ IgG-Fc fusion protein comprising: a first IL-7R $\alpha\gamma\epsilon$ IgG-Fc fusion fragment of claim 13; and a second IL-7R $\alpha\gamma\epsilon$ IgG-Fc fusion fragment of claim 13, wherein the IgG-Fc of the first IL-7R $\alpha\gamma\epsilon$ IgG-Fc fusion fragment comprises a first hinge region; wherein the IgG-Fc of the second IL-7R $\alpha\gamma\epsilon$ IgG-Fc fusion fragment comprises a second hinge region; and wherein the first IL-7R $\alpha\gamma\epsilon$ IgG-Fc fusion fragment and the second first IL-7R $\alpha\gamma\epsilon$ IgG-Fc fusion fragment are bound to each other at the first hinge region and the second hinge region through disulfide bonds.

24. The IL-7R $\alpha\gamma\epsilon$ IgG-Fc fusion protein of claim 23, wherein the first IL-7R $\alpha\gamma\epsilon$ IgG-Fc fusion fragment and the second IL-7R $\alpha\gamma\epsilon$ IgG-Fc fusion fragment have the same amino acid sequence.

25. The IL-7R $\alpha\gamma\epsilon$ IgG-Fc fusion protein of claim 23, wherein the first IL-7R $\alpha\gamma\epsilon$ IgG-Fc fusion fragment and the second IL-7R $\alpha\gamma\epsilon$ IgG-Fc fusion fragment comprise different amino acid sequences.

26. The IL-7R $\alpha\gamma\epsilon$ IgG-Fc fusion protein of claim 23, wherein the first IL-7R $\alpha\gamma\epsilon$ IgG-Fc fusion fragment and the second IL-7R $\alpha\gamma\epsilon$ IgG-Fc fusion fragment comprise a different IL-7R α ligand.

27. The IL-7R $\alpha\gamma\epsilon$ IgG-Fc fusion protein of claim 23, wherein the first IL-7R $\alpha\gamma\epsilon$ IgG-Fc fusion fragment and the second IL-7R $\alpha\gamma\epsilon$ IgG-Fc fusion fragment comprise a different R $\gamma\epsilon$ ligand.

28. A pharmaceutical composition comprising the IL-7R $\alpha\gamma\epsilon$ ligand of claim 1.

29. A pharmaceutical composition comprising the IL-7R $\alpha\gamma\epsilon$ IgG-Fc fusion protein of claim 13.

* * * * *