

Jan. 14, 1930.

E. GALLAGHER

1,744,003

SUPPLEMENTARY OUTSOLE FOR BOOTS AND SHOES

Filed April 7, 1928

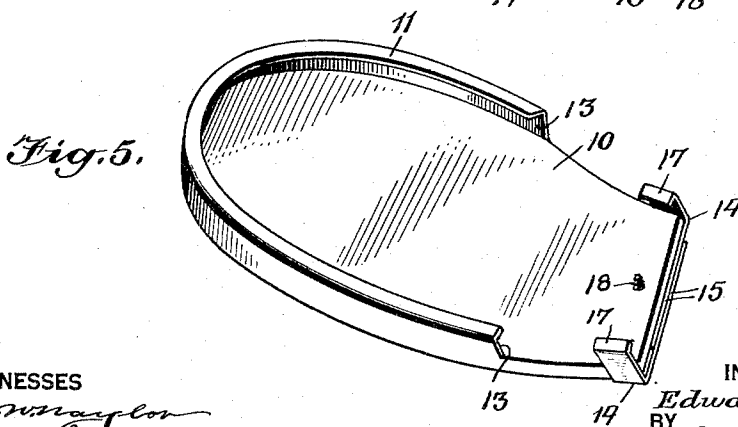
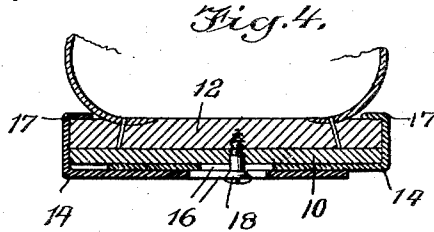
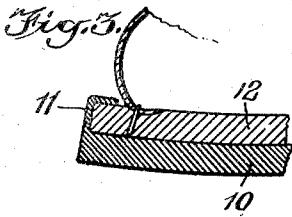
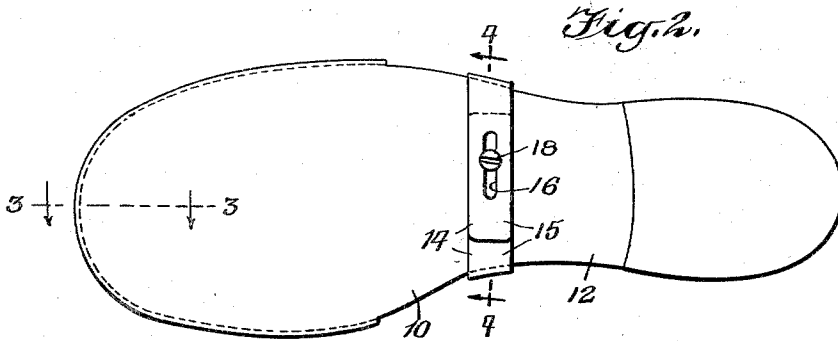
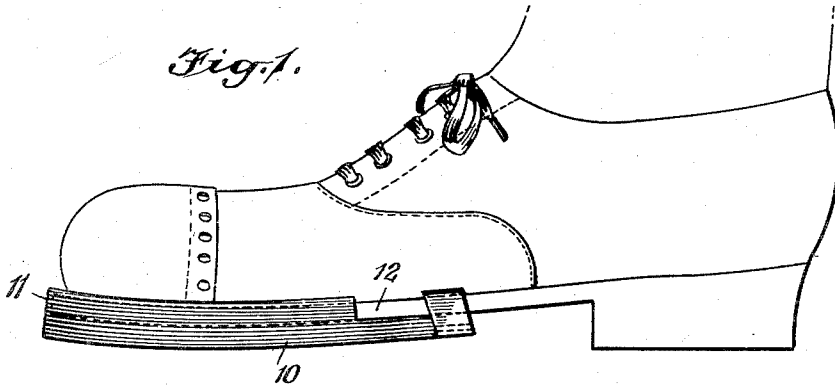

WITNESSES
Geo. Maylor
Chris Feinke

INVENTOR
Edward Gallagher
BY *Mum & Co.*
ATTORNEY

UNITED STATES PATENT OFFICE

EDWARD GALLAGHER, OF BROOKLYN, NEW YORK

SUPPLEMENTARY OUTSOLE FOR BOOTS AND SHOES

Application filed April 7, 1928. Serial No. 268,278.

This invention relates to footwear, such as boots and shoes, and relates more particularly to treads or supplementary outsoles for boots and shoes.

The principal object of the invention is to provide treads or supplementary outsoles which may be readily applied by an unskilled person to worn boots or shoes to repair them for further use, or for the purpose of preserving those outsoles already on the boots or shoes when being worn outdoors in wet weather and for hiking over rough roads.

With the foregoing, other objects will appear from the embodiment of the invention which by way of example is described in the following specification and illustrated in the accompanying drawing, in which:

Figure 1, is a side view of a shoe with a supplementary outsole or tread applied thereto.

Fig. 2, is a bottom plan view.

Fig. 3, is a sectional view taken on the line 3—3, of Fig. 2.

Fig. 4, is a sectional view taken on the line 4—4, of Fig. 2.

Fig. 5, is a perspective view of the supplementary outsole or tread.

In accordance with the invention use is made of a piece of leather or like material which is cut to any desired size and shape for boots and shoes of different sizes and shapes. The cut piece of leather 10 is then molded to provide integral means 11 conforming to and engageable over the marginal edge of the outsole 12 of a boot or shoe. The said means 11 is in the form of a substantially L-shaped flange extending along the marginal edge of the piece of leather from the tip rearwardly a certain distance at each side presenting open ends 13. The piece of leather thus formed and constructed constitutes a tread or outsole adapted to be used for the purpose of repairing worn outsoles of boots or shoes, and as a supplementary tread or outsole for those outsoles already on boots or shoes. Such tread or supplementary outsole is tempered or hardened according to known methods to make the L-shaped flange 11 stand up to effectively grip the boot or shoe outsole. The said flange 11 is so posi-

tioned and formed as to allow the tread or supplementary outsole to be slid over the boot or shoe outsole from the tip with the flange 11 engaged over a corresponding edge portion of the outsole 12.

In order to securely hold the tread or supplementary outsole 10 in place on the boot or shoe, there is provided means which cooperates with the flange 11, and which in the present instance consists of clips 14 of similar construction, preferably of hardened leather. Each clip 14 consists of a member 15 having a slot 16, and an L-shaped or angular member 17. The clips 14 are brought together transversely of the shank end of the tread or supplementary outsole, and a suitable fastening element, such as a screw 18, is projected through the slots 16, which register with each other, and said screw 18 is screwed into the shank end of the outsole 10. The clips 14 may thus be held in set positions with the members 17 in engagement over shank of the outsole 12. The clips 14 may remain associated with the outsole 10, and may be readily adjusted by loosening the screw 18 in applying or detaching the outsole 10. The screw 18 may be of a length to be screwed into the shank of the outsole 12 of the boot or shoe. By providing means such as the clips 14 adapted to engage over the shank of the boot or shoe outsole, the tread or supplementary outsole 10 will be prevented from slipping or otherwise moving relatively to the outsole 12, it being apparent that the clips 14 cooperate with the flange 11 for this purpose. It will also be apparent that the clips 14 may be loosened to allow the tread or supplementary outsole 10 to be readily slid off.

It is to be understood that the treads or supplementary outsoles together with the clips or the like will be sold with each pair of new shoes or boots or as separate items.

I claim:

For use in conjunction with a boot or shoe to provide a tread therefor, a supplementary outsole having means conforming to and engageable over the edge of the outsole on the boot or shoe, and means to secure the supplementary outsole to the outsole on the boot

or shoe, said last mentioned means comprising a fastening element carried by the supplementary outsole adapted to be secured to the shank of the boot or shoe sole, and clips associated with said fastening element for relative movement, said clips being engageable with said shank, and said fastening element also serving to hold said clips in the shank engaging positions.

10 Signed at Brooklyn, in the county of Kings and State of New York this 4th day of April A. D. 1928.

EDWARD GALLAGHER.

15

20

25

30

35

40

45

50

55

60

65