



US 20170297764A1

(19) **United States**

(12) **Patent Application Publication**
Allegretti et al.

(10) **Pub. No.: US 2017/0297764 A1**

(43) **Pub. Date: Oct. 19, 2017**

(54) **BULK MATERIAL SHIPPING CONTAINER**

B65D 88/00 (2006.01)

(71) Applicant: **Arrows Up, LLC**, Arlington Heights, IL (US)

B65D 90/04 (2006.01)

B65D 90/14 (2006.01)

B65D 90/58 (2006.01)

(72) Inventors: **C. John Allegretti**, Barrington Hills, IL (US); **Anthony M. Raso**, West Dundee, IL (US); **Lyndon Just**, Elgin, IL (US)

B65D 88/02 (2006.01)

B65D 90/00 (2006.01)

(21) Appl. No.: **15/637,325**

(52) **U.S. Cl.**

CPC *B65D 19/06* (2013.01); *B65D 88/022* (2013.01); *B65D 88/54* (2013.01); *B65D 90/0033* (2013.01); *B65D 90/046* (2013.01); *B65D 90/14* (2013.01); *B65D 90/58* (2013.01); *B65D 88/005* (2013.01); *B65D 2519/00273* (2013.01); *B65D 2519/00199* (2013.01); *B65D 2519/00164* (2013.01); *B65D 2519/00064* (2013.01); *B65D 2519/00029* (2013.01); *B65D 2519/00333* (2013.01); *B65D 2519/00502* (2013.01); *B65D 2519/00562* (2013.01); *B65D 2519/00567* (2013.01); *B65D 2519/00721* (2013.01); *B65D 2519/00786* (2013.01); *B65D 2519/0096* (2013.01); *B65D 2519/0086* (2013.01)

(22) Filed: **Jun. 29, 2017**

Related U.S. Application Data

(63) Continuation of application No. 15/634,383, filed on Jun. 27, 2017, which is a continuation of application No. 15/632,696, filed on Jun. 26, 2017, which is a continuation of application No. 15/631,737, filed on Jun. 23, 2017, which is a continuation of application No. 15/471,896, filed on Mar. 28, 2017, which is a continuation of application No. 14/516,292, filed on Oct. 16, 2014, now Pat. No. 9,617,065, which is a continuation of application No. 13/249,688, filed on Sep. 30, 2011, now Pat. No. 8,887,914, which is a continuation-in-part of application No. 12/914,075, filed on Oct. 28, 2010, now Pat. No. 8,616,370.

Publication Classification

(51) **Int. Cl.**

B65D 19/06 (2006.01)

B65D 88/54 (2006.01)

(57)

ABSTRACT

A bulk material shipping container including a pallet, a compartment mounted on the pallet, a material unloading assembly, and a material loading assembly.

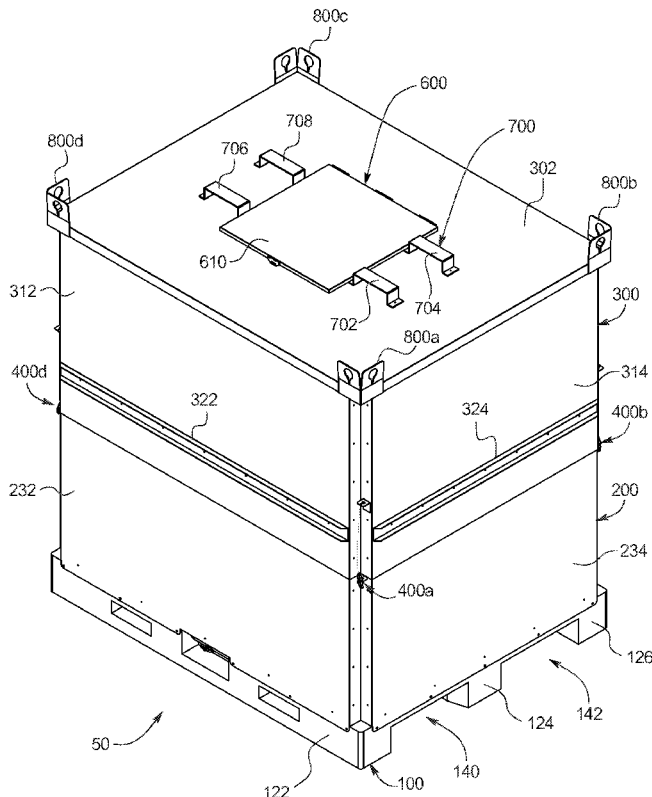
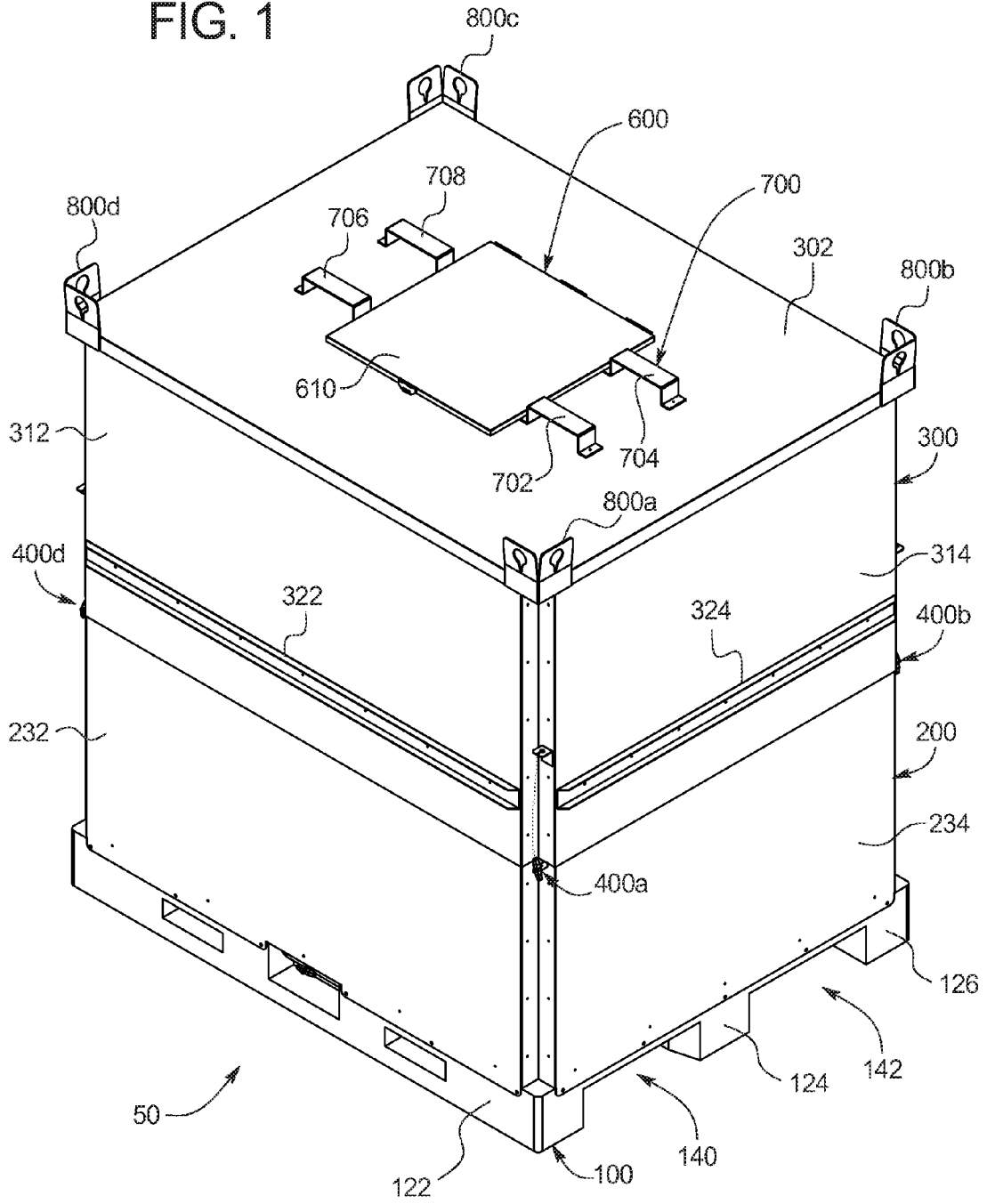

FIG. 1



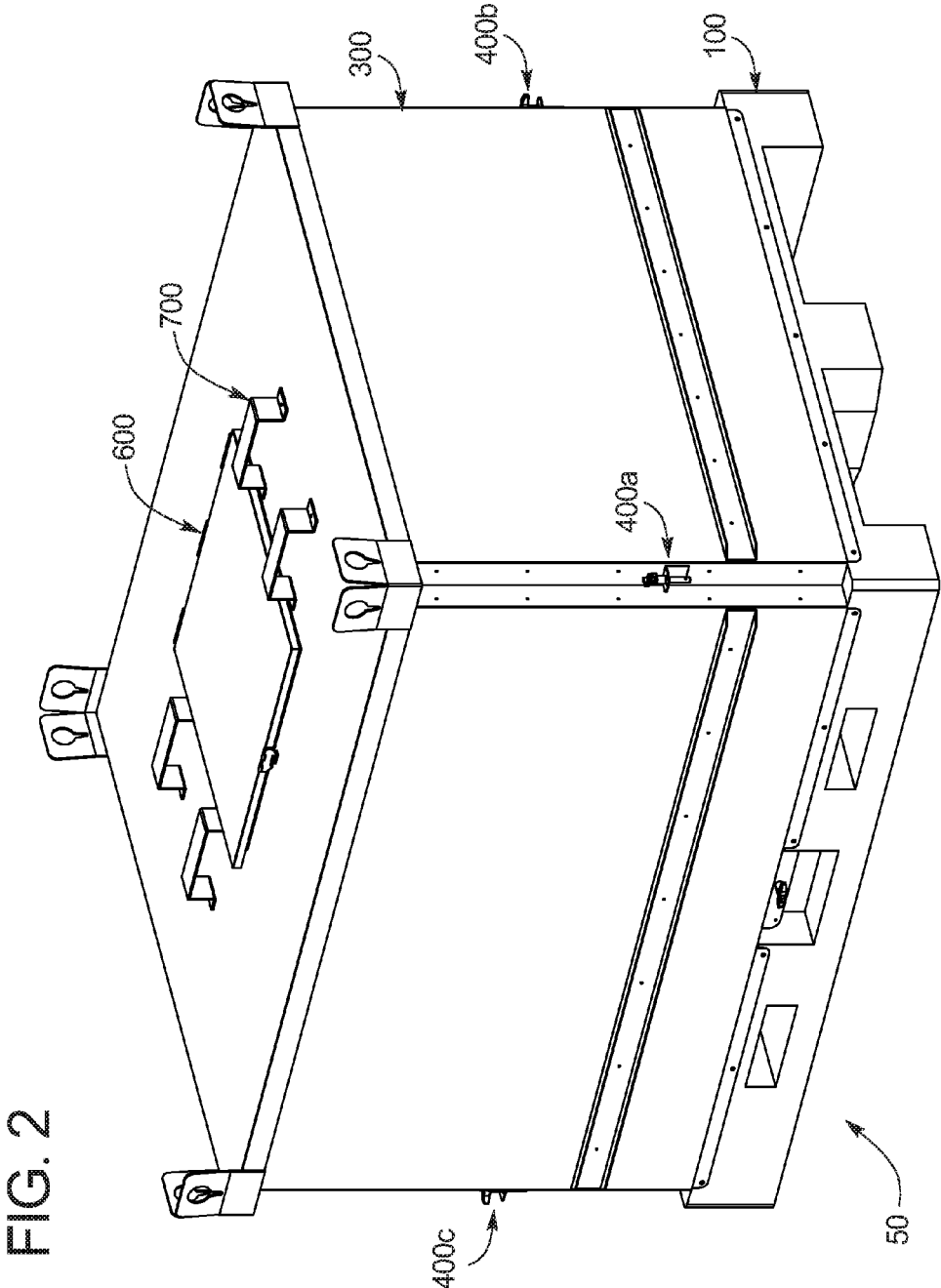

FIG. 2

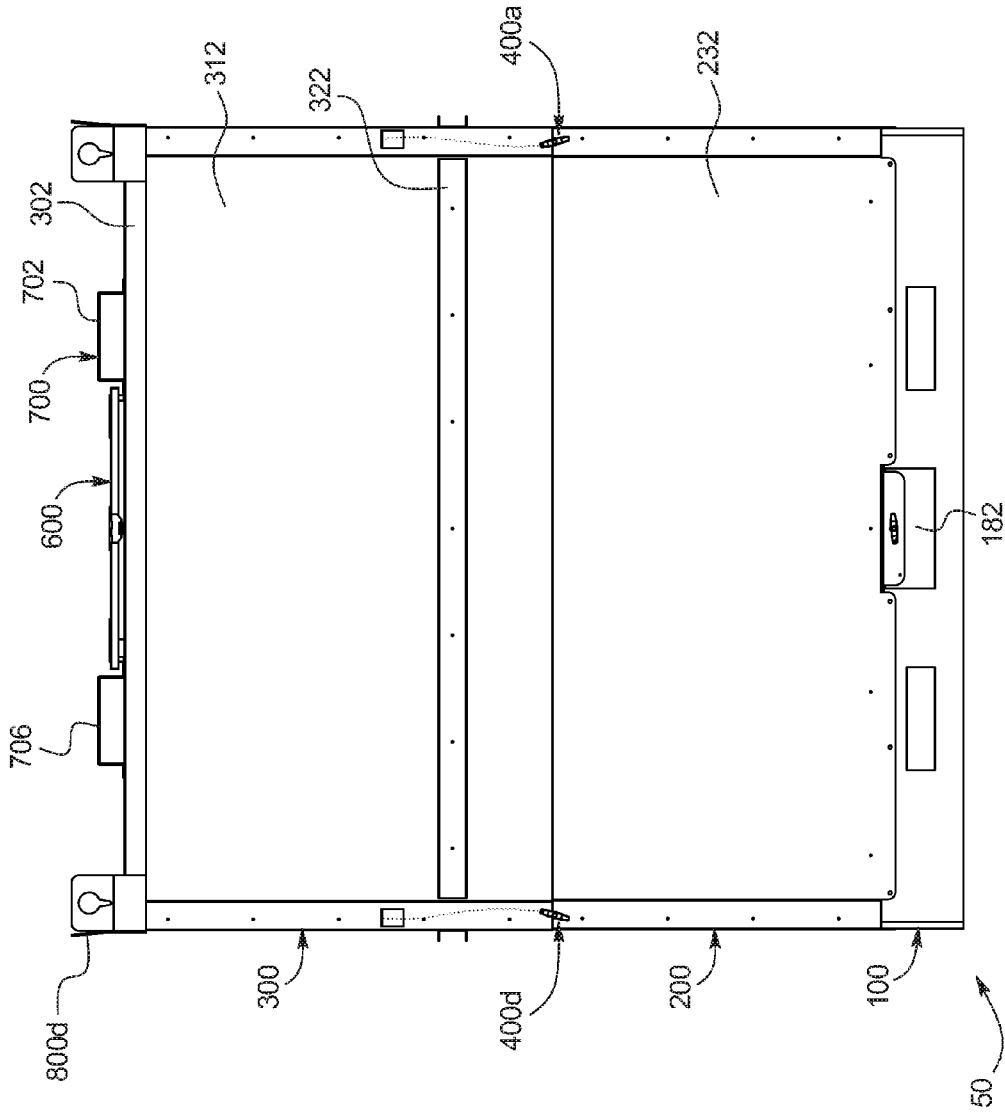

FIG. 4

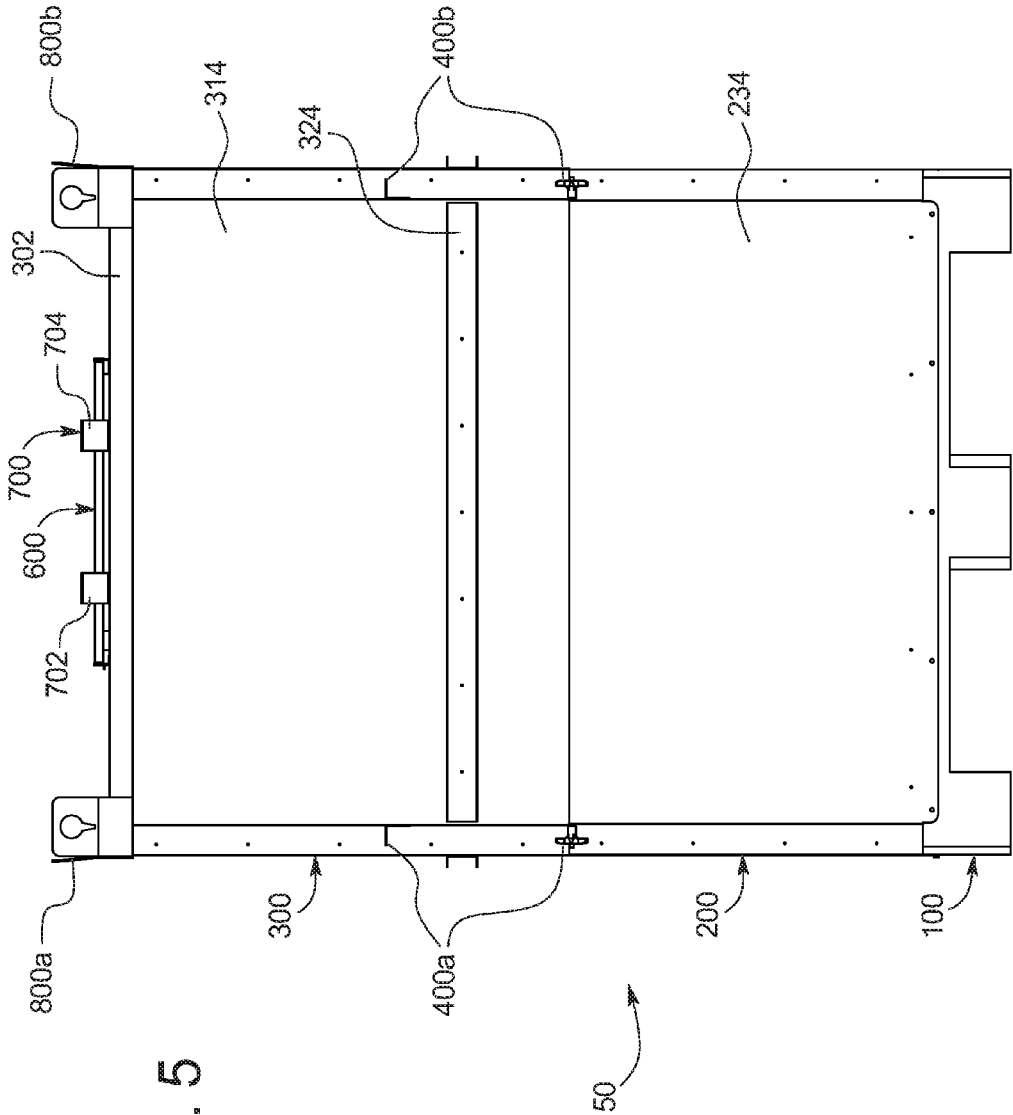

FIG. 5

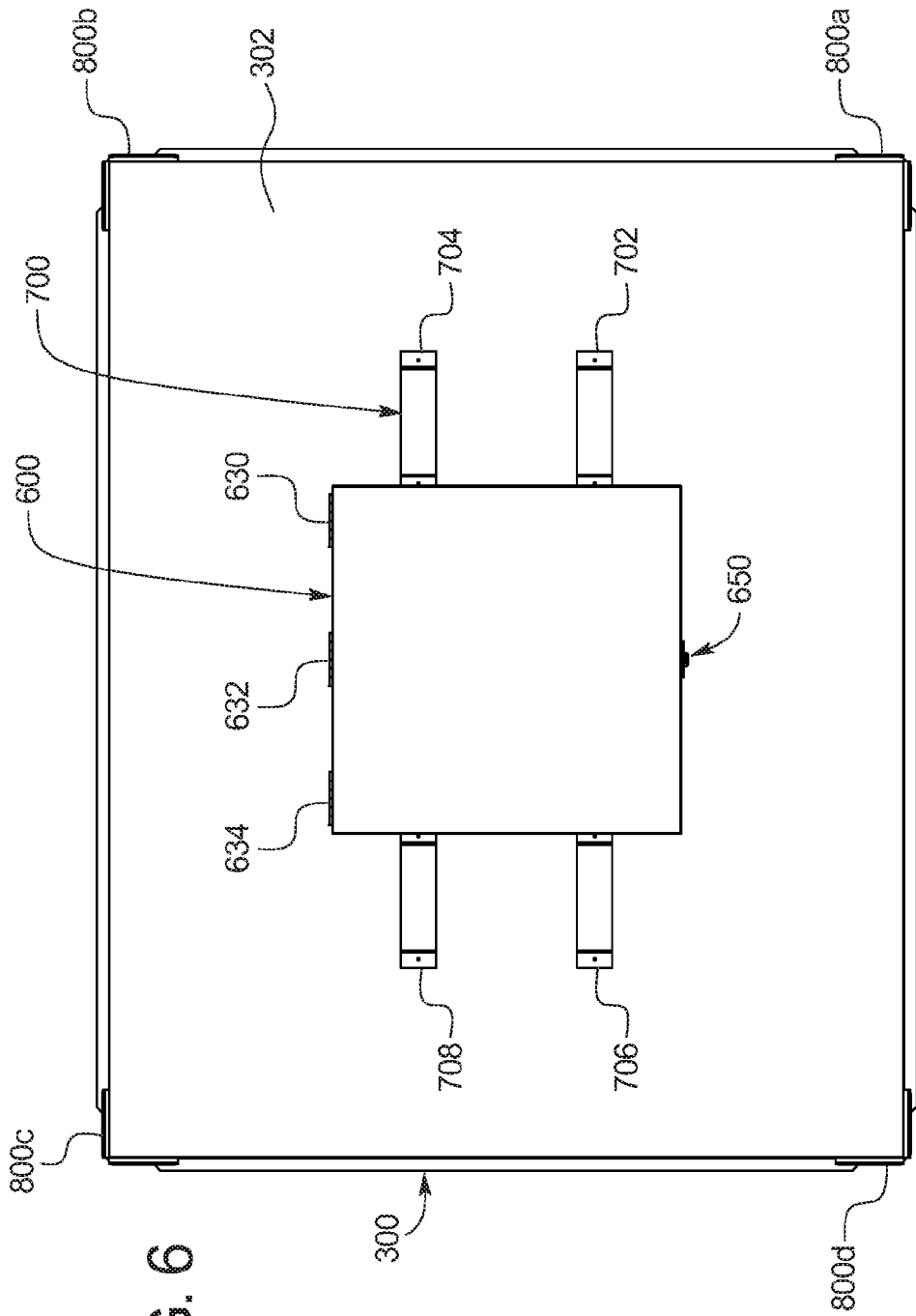

FIG. 6

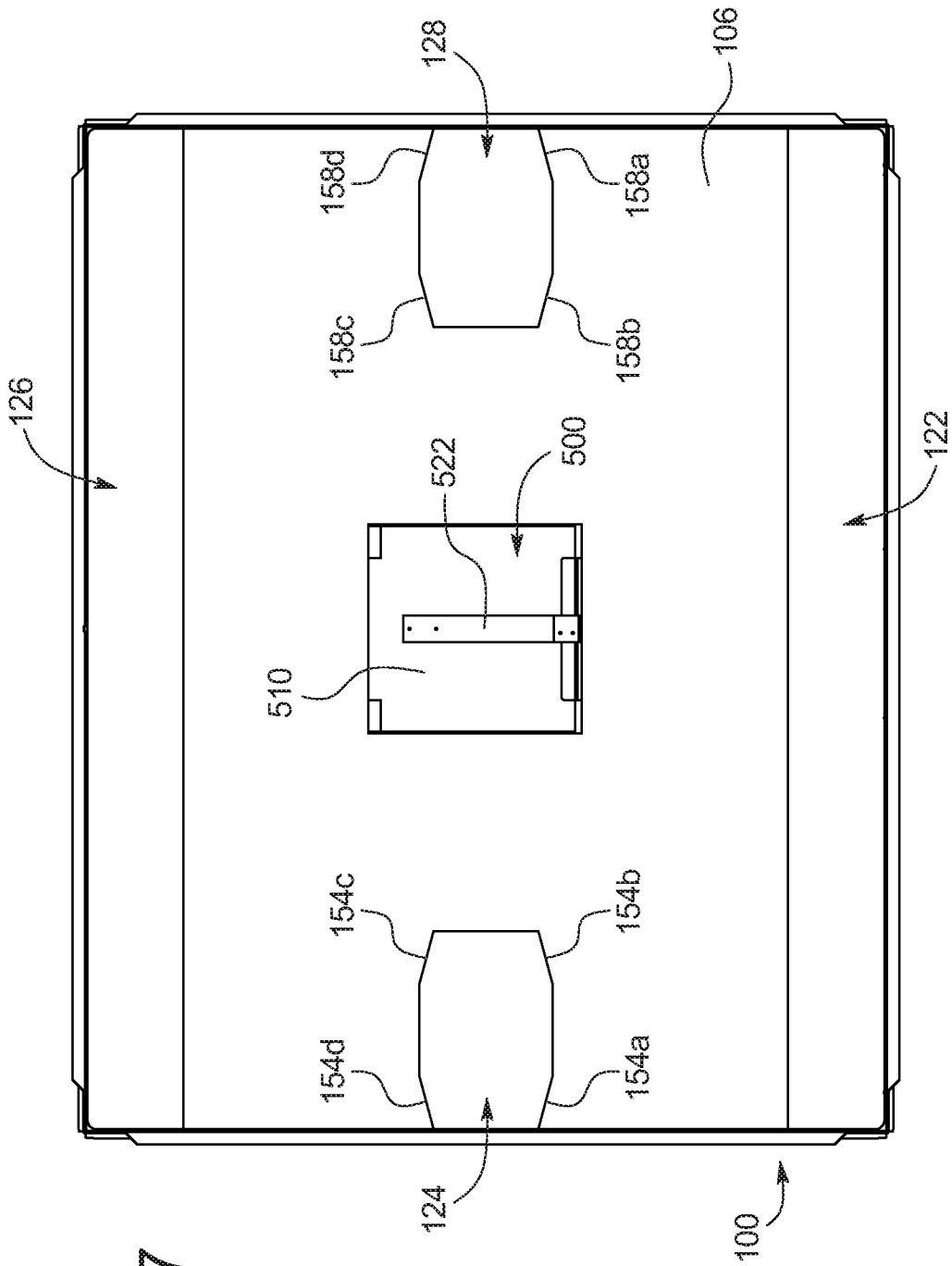

FIG. 7

FIG. 8

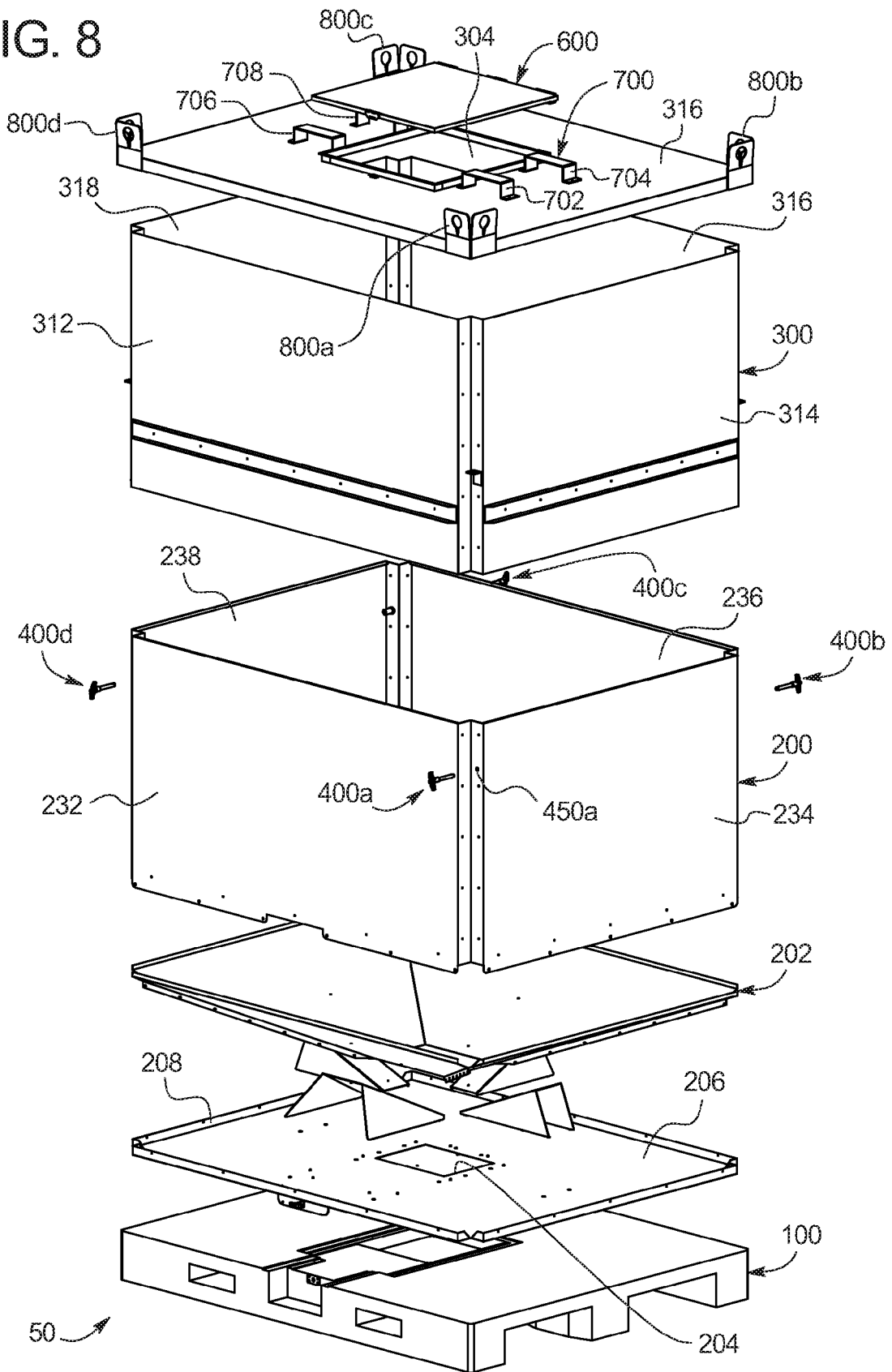
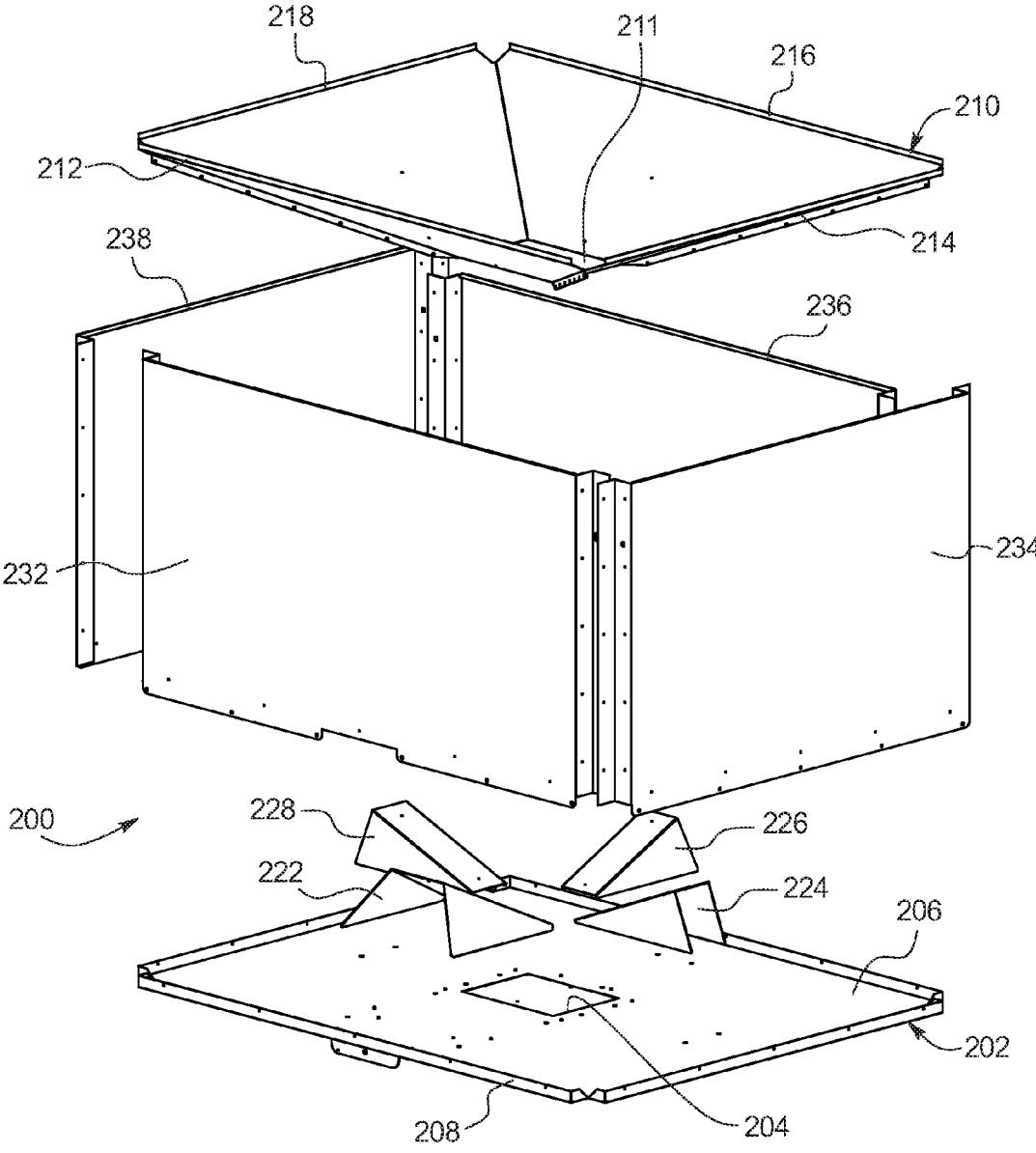

FIG. 9



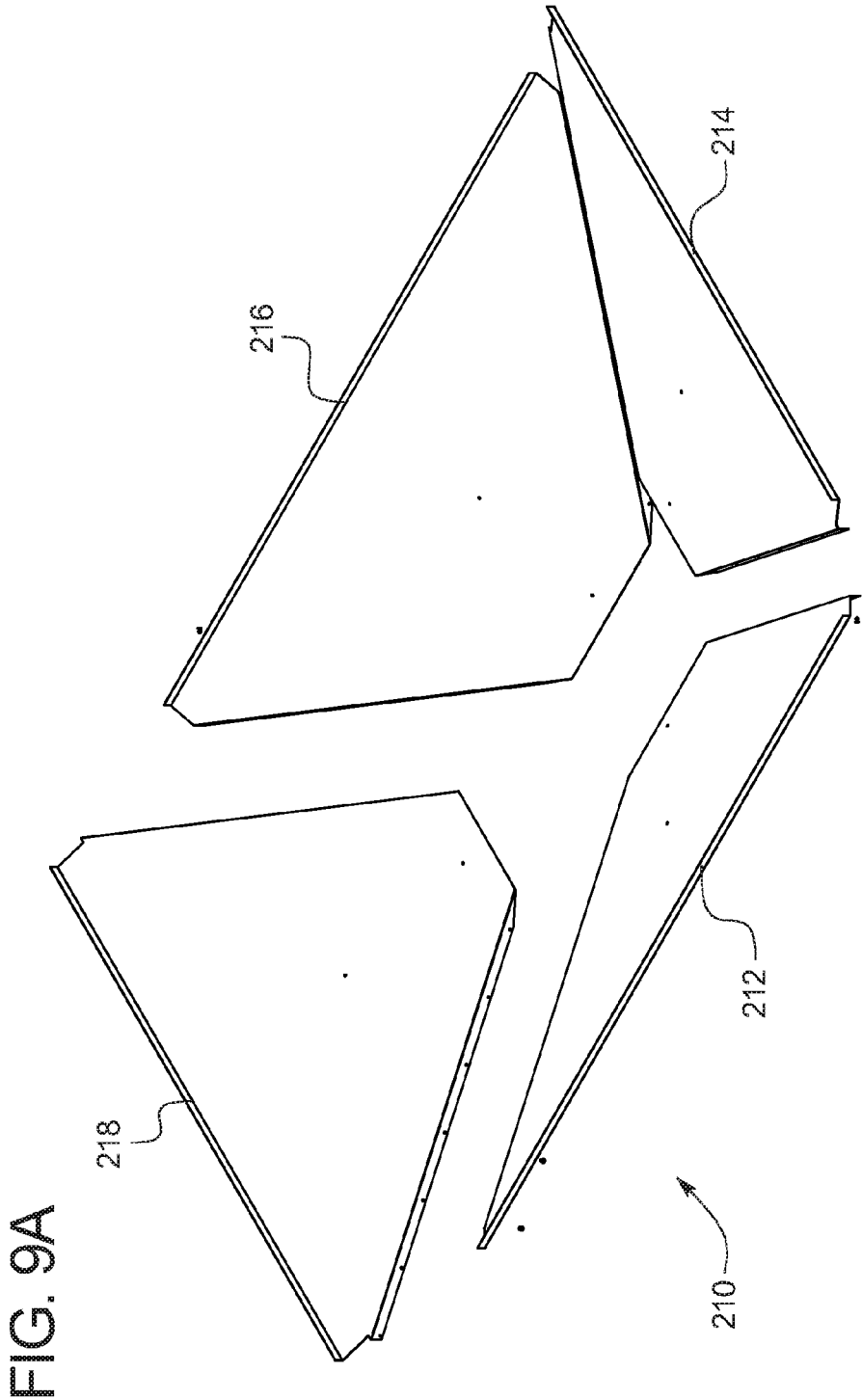
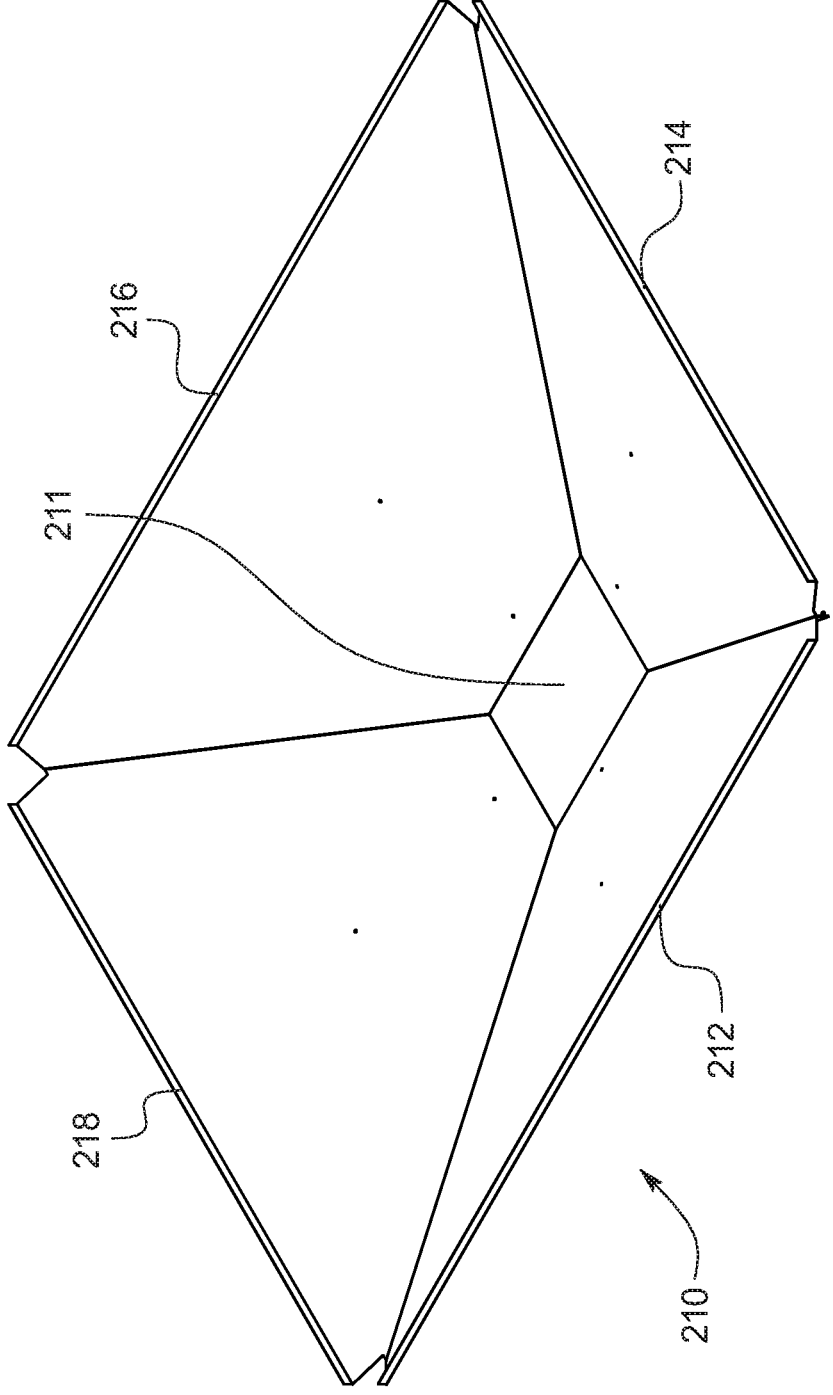

FIG. 9B



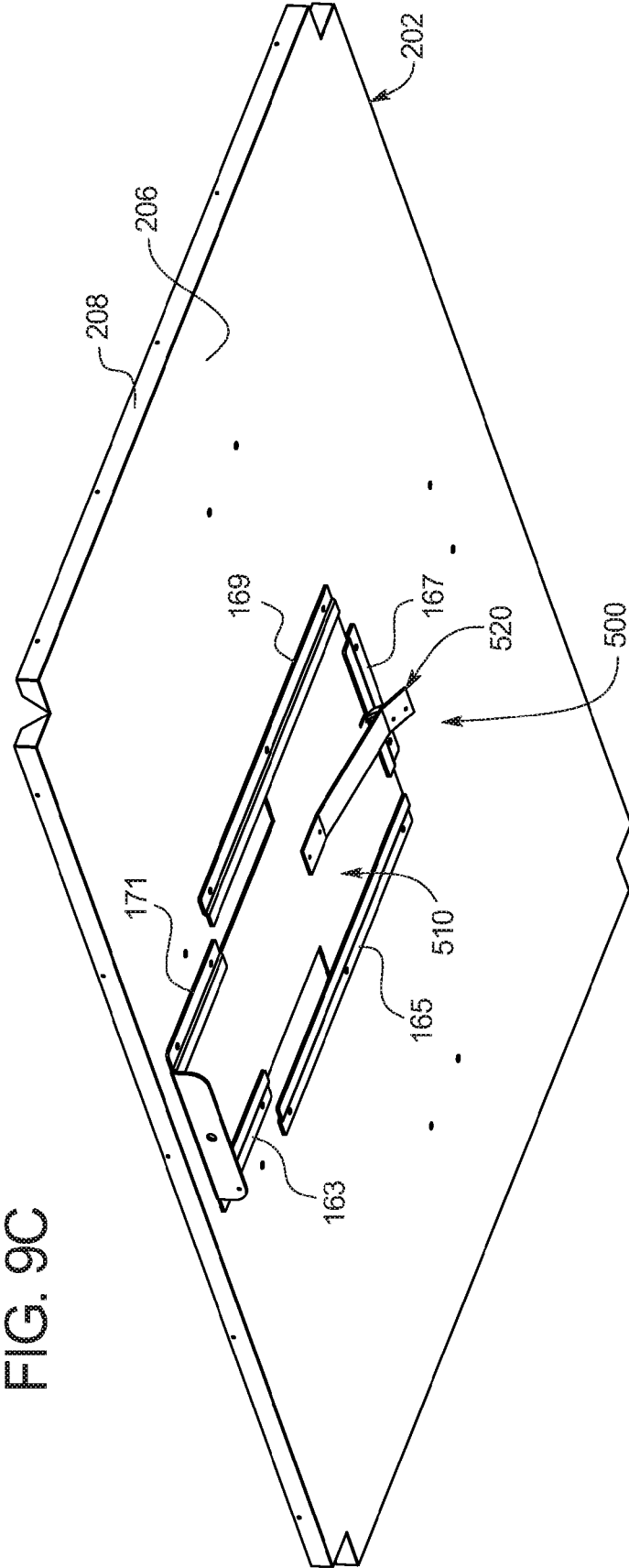

FIG. 9C

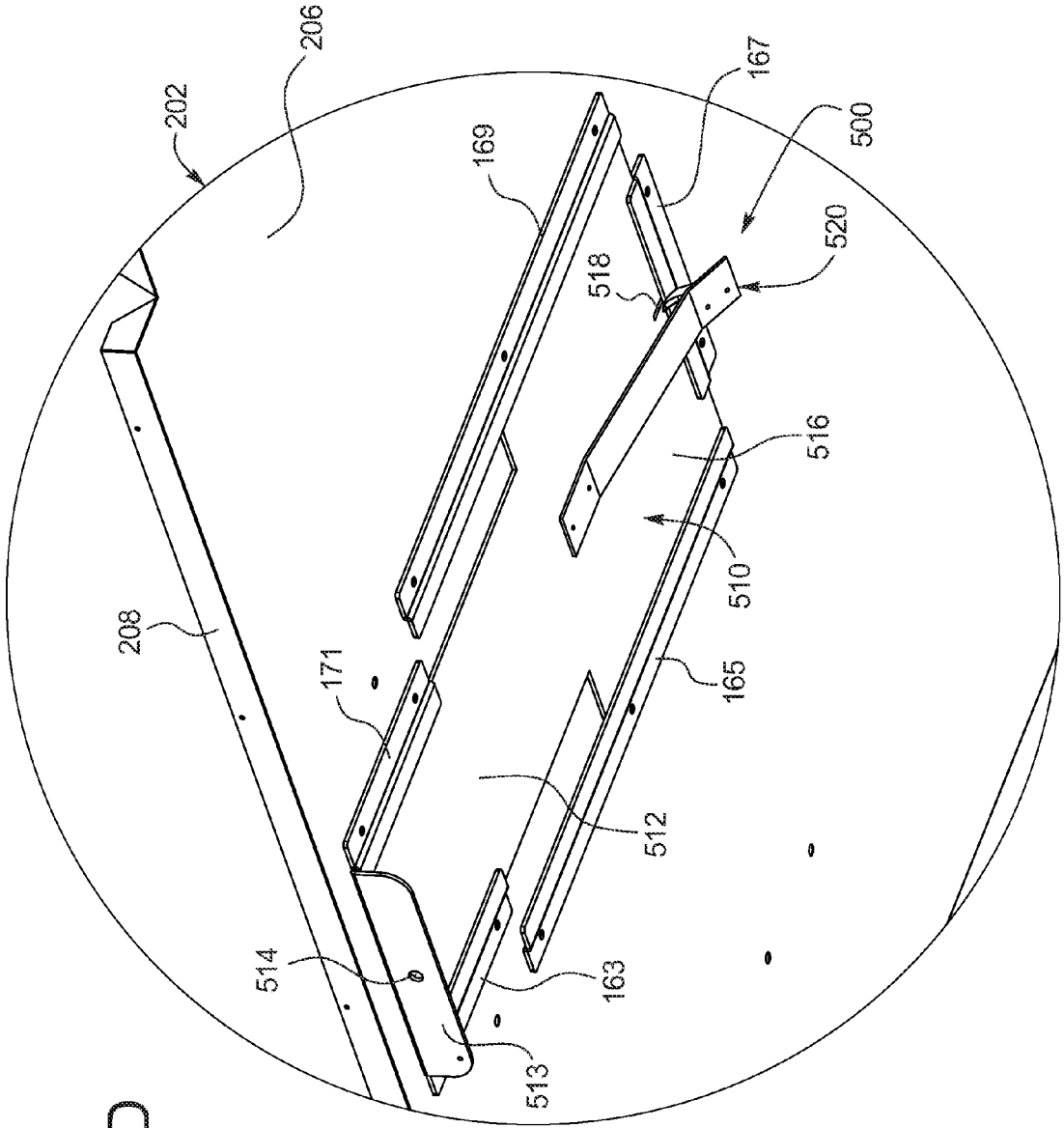
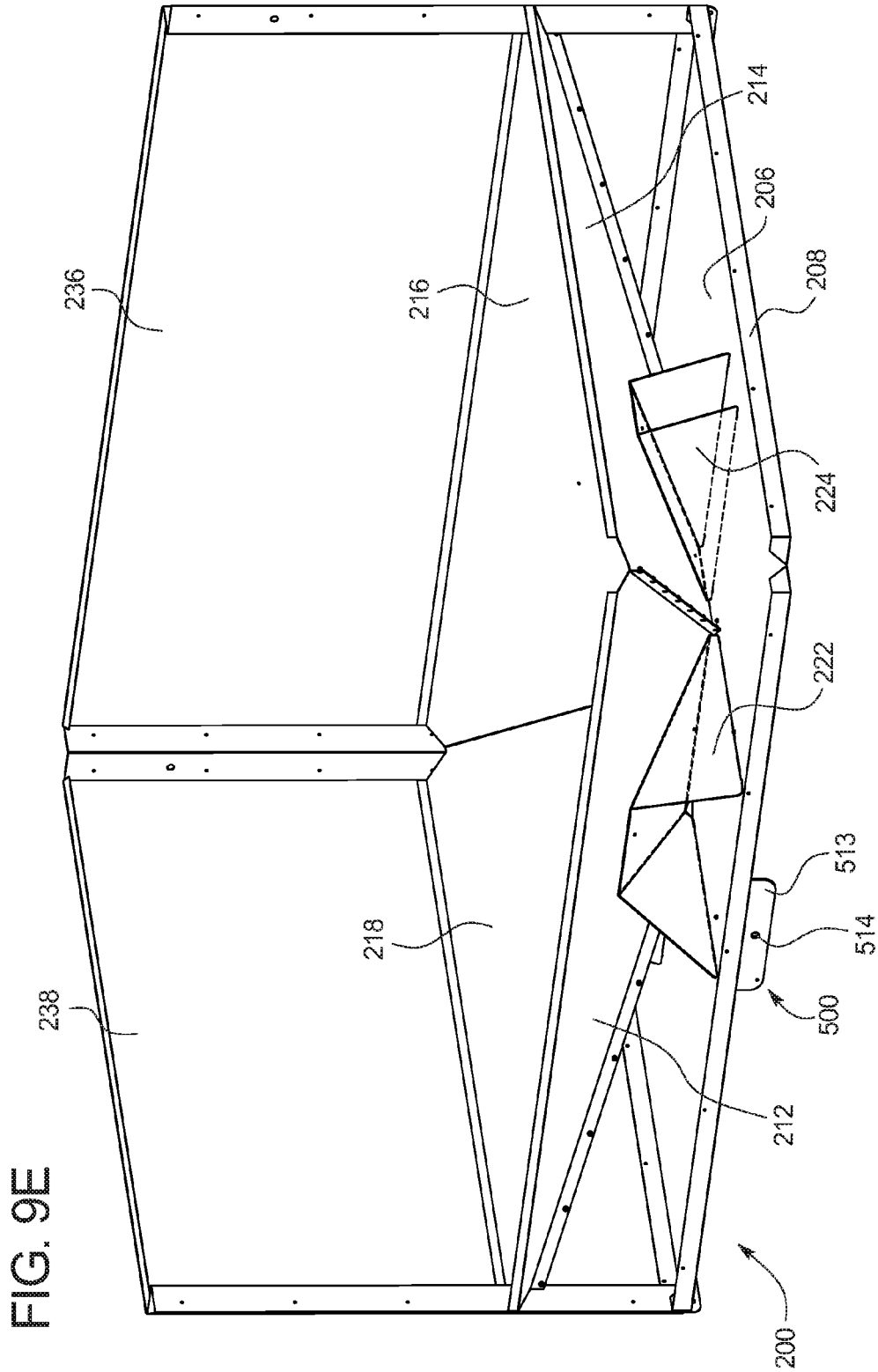
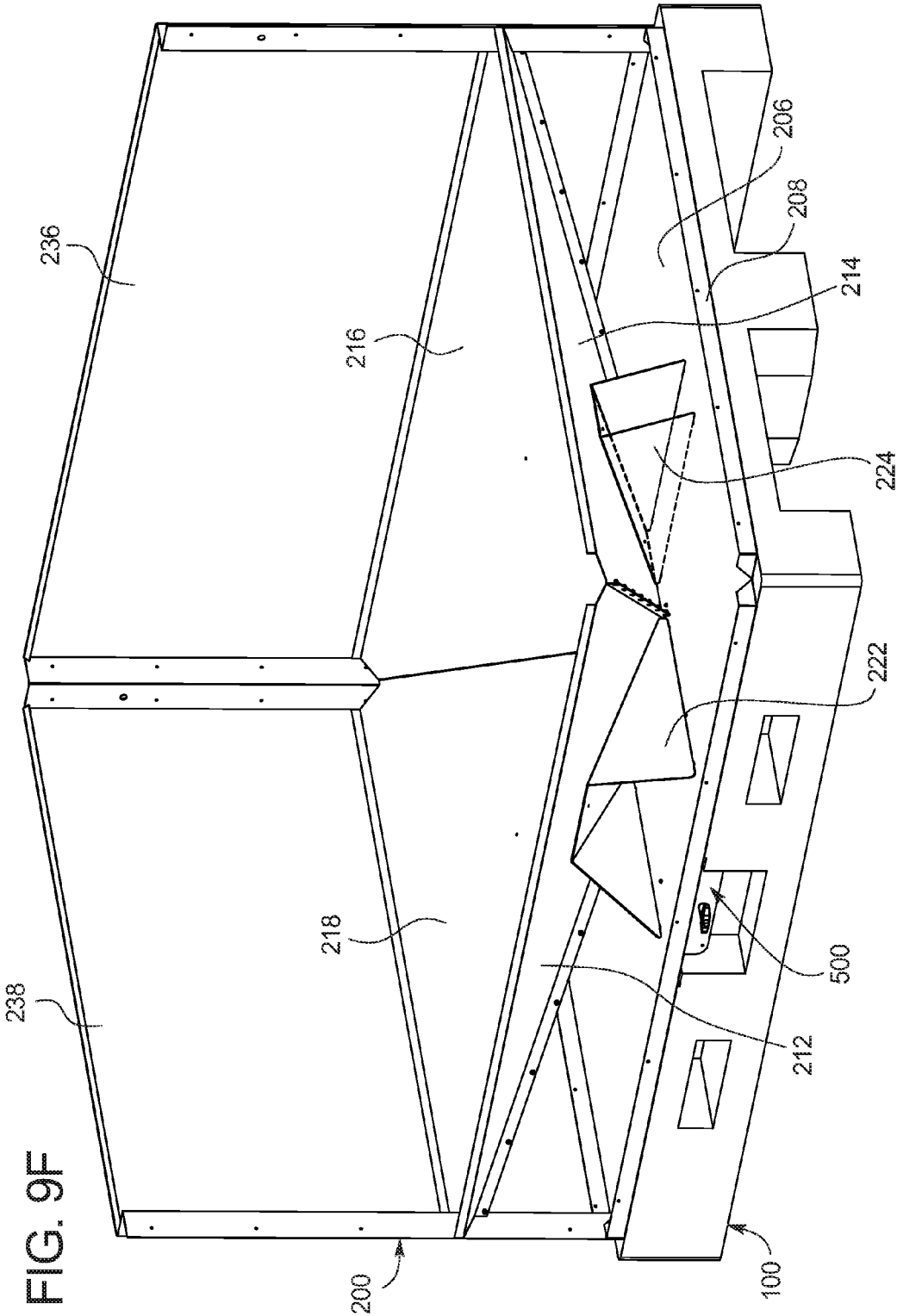

FIG. 9D





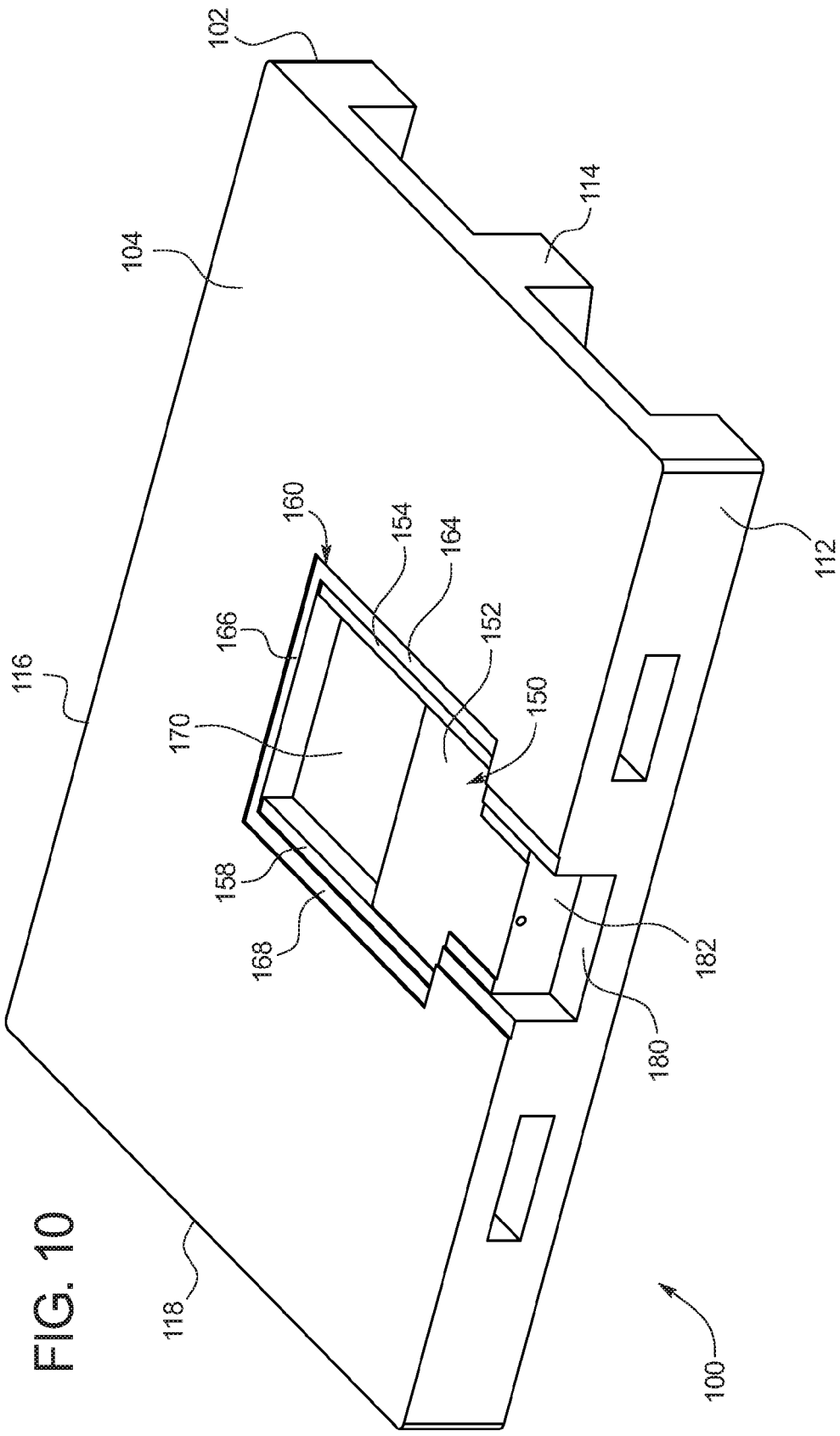

FIG. 10

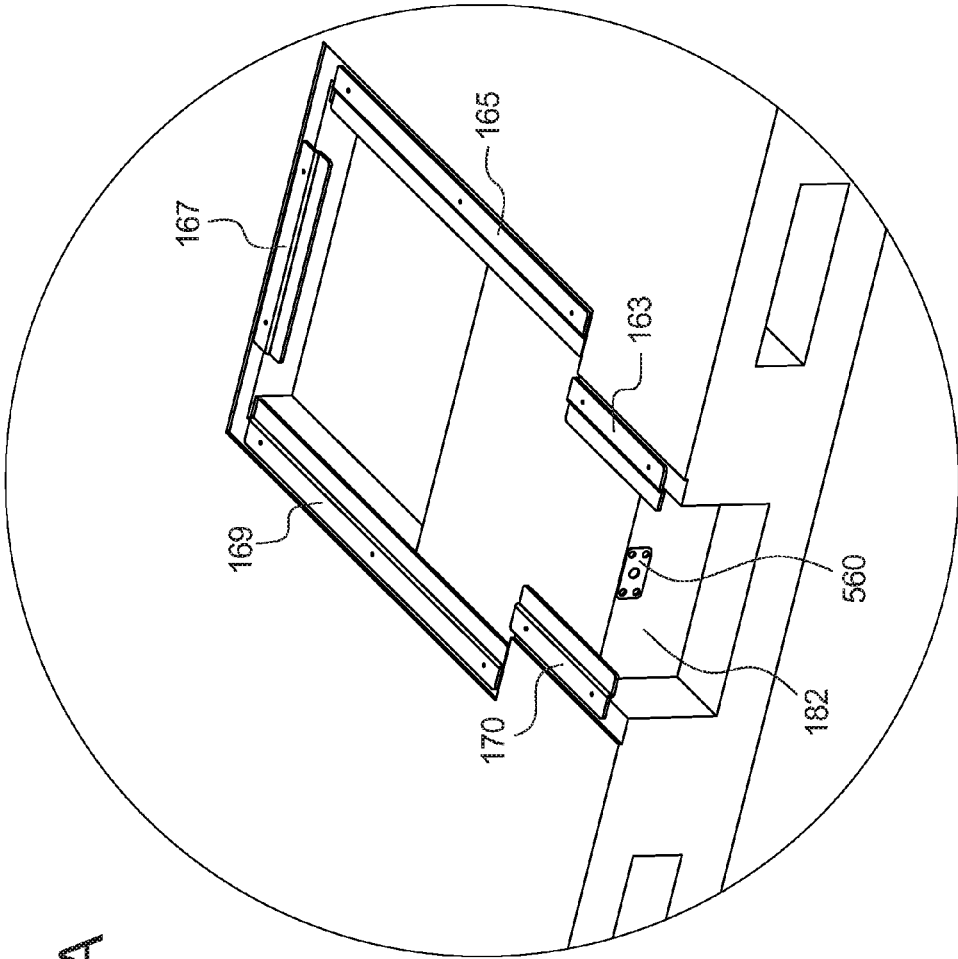

FIG. 10A

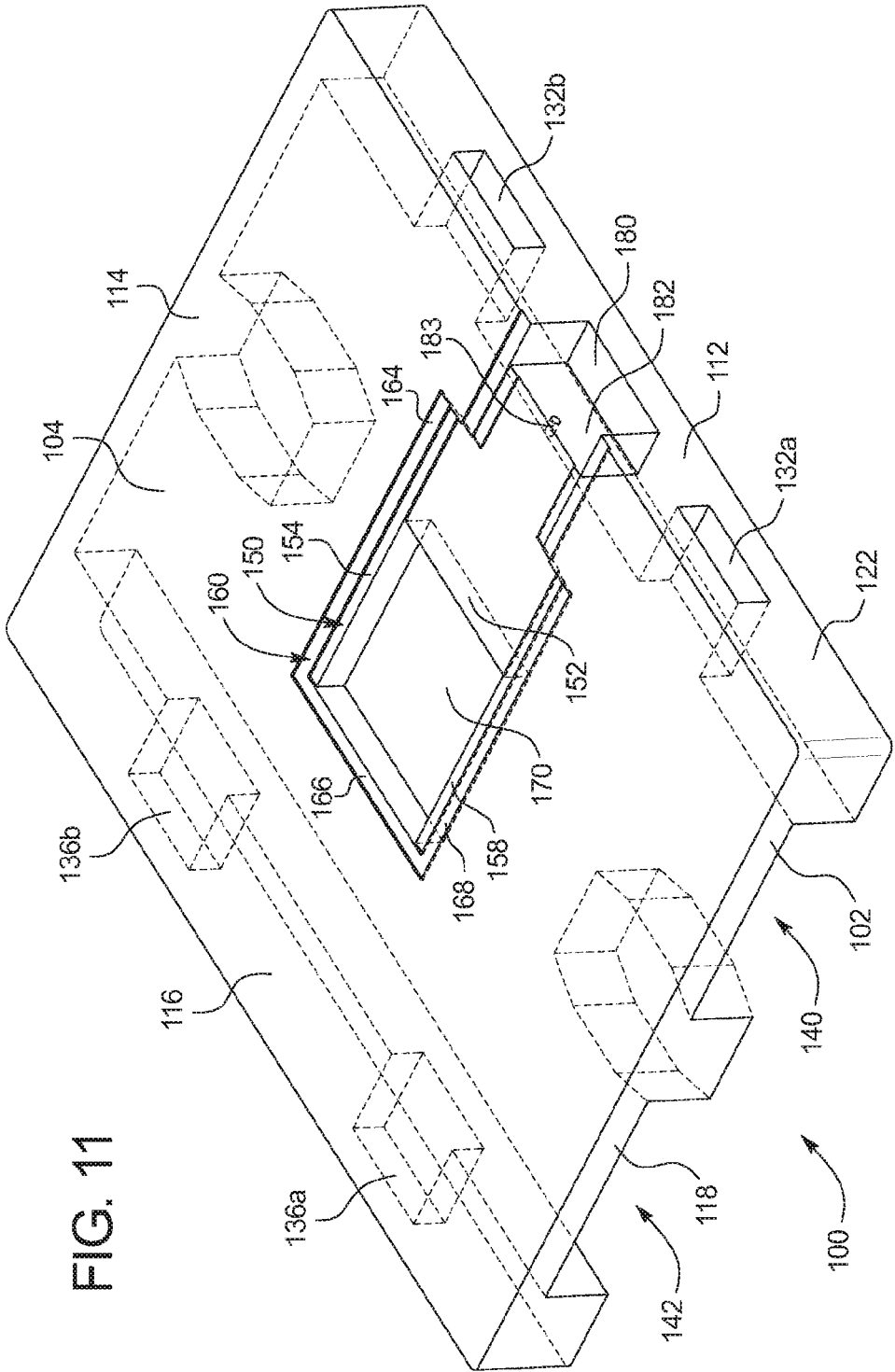

FIG. 11

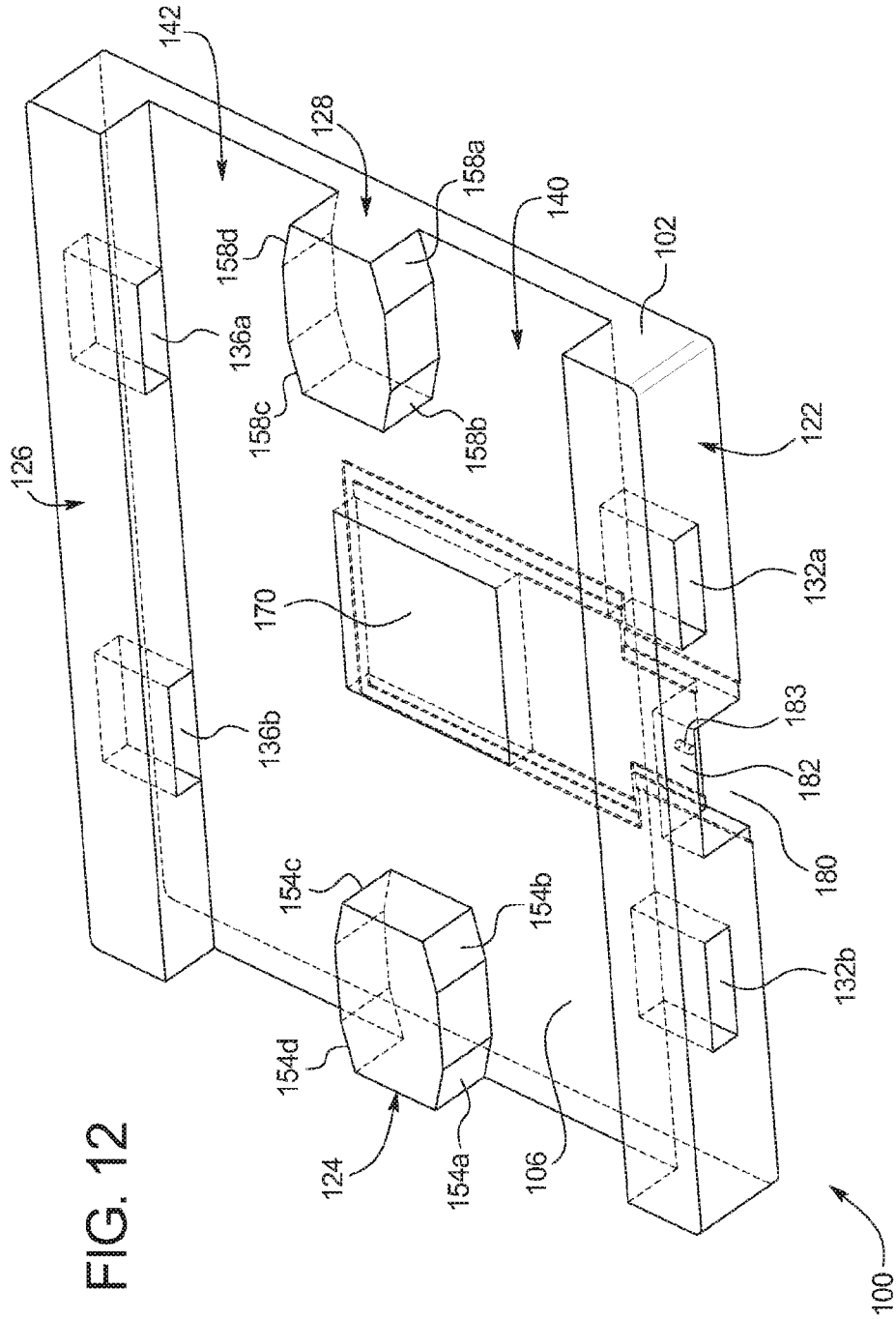
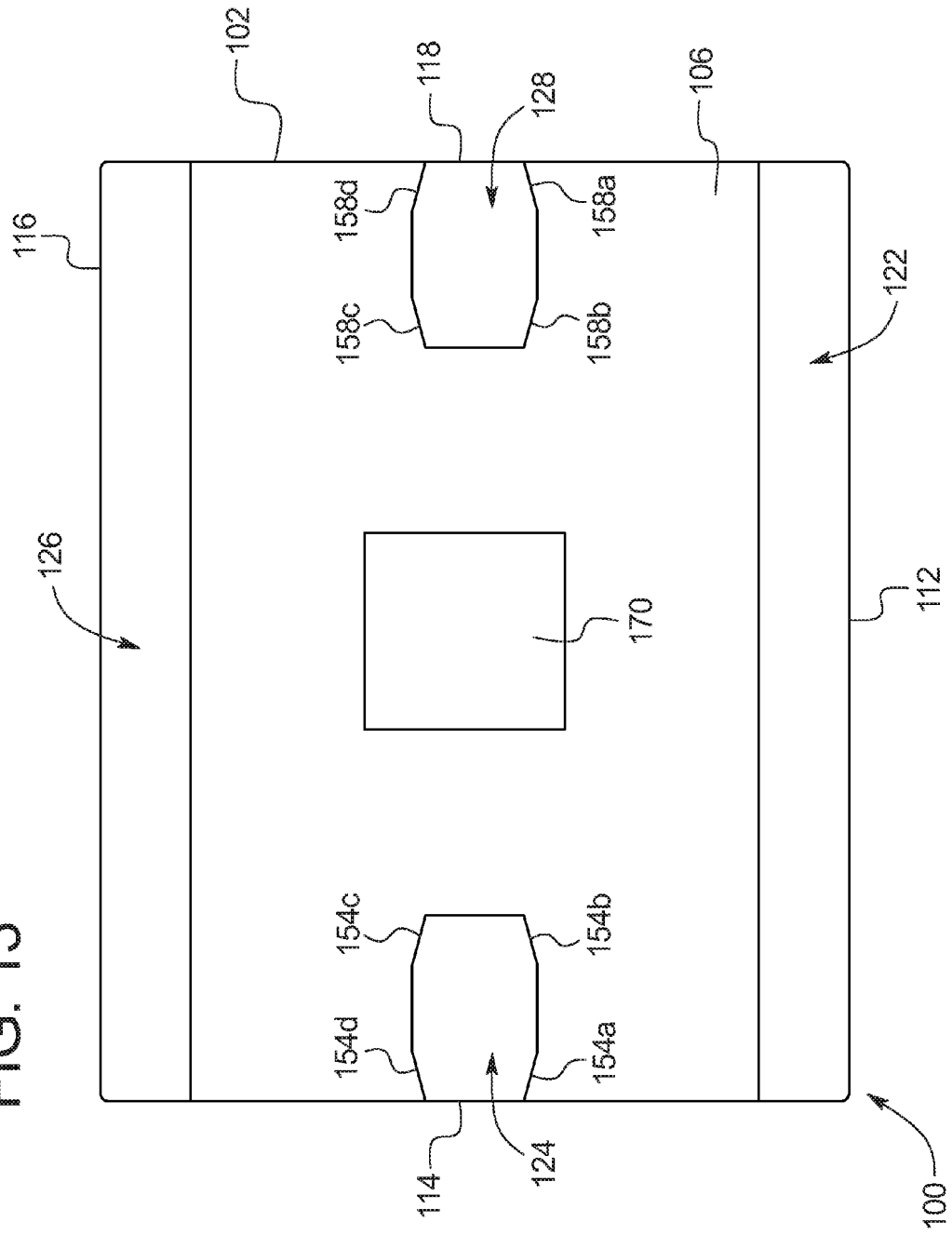

FIG. 13



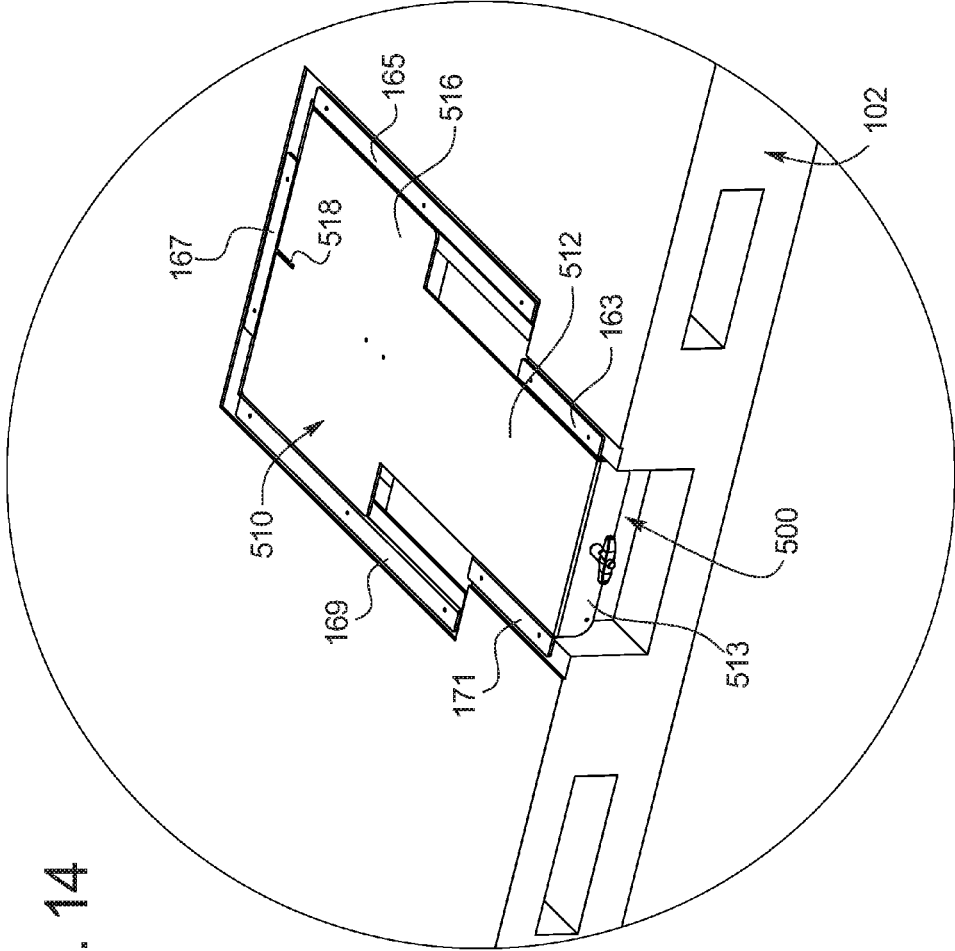

FIG. 14

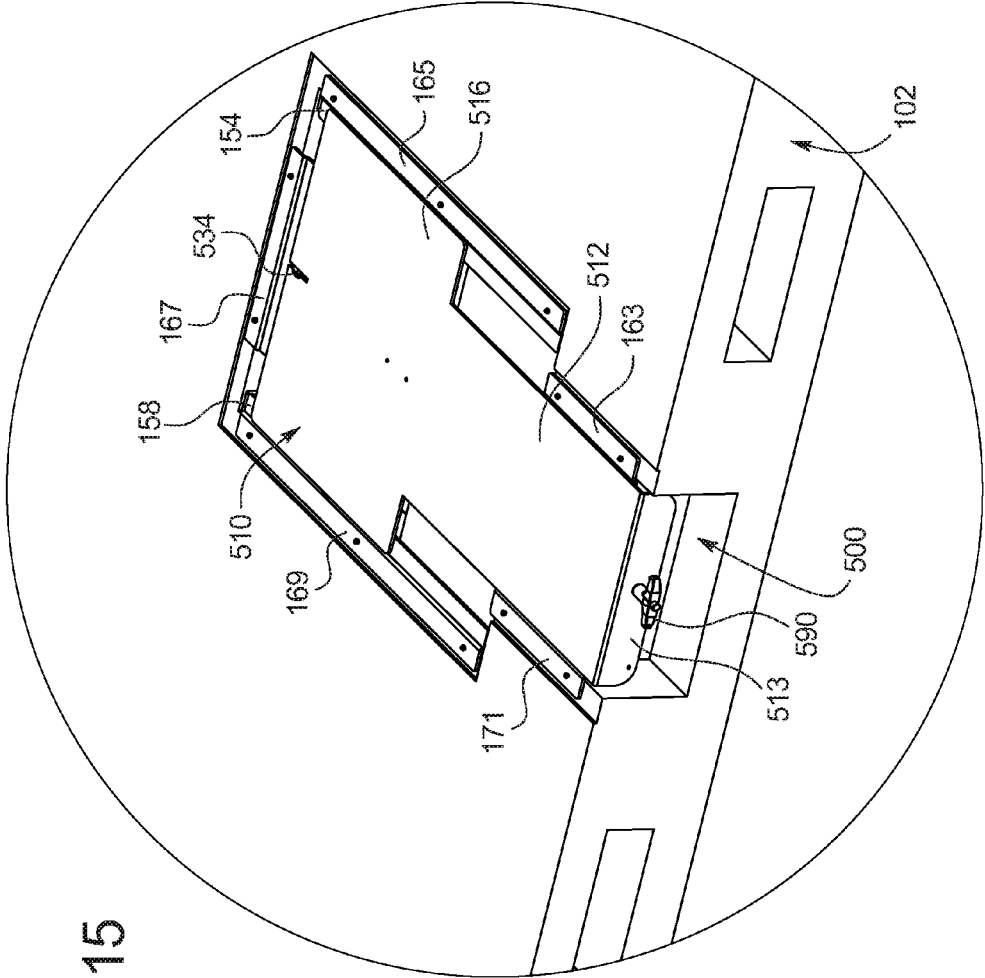

FIG. 15

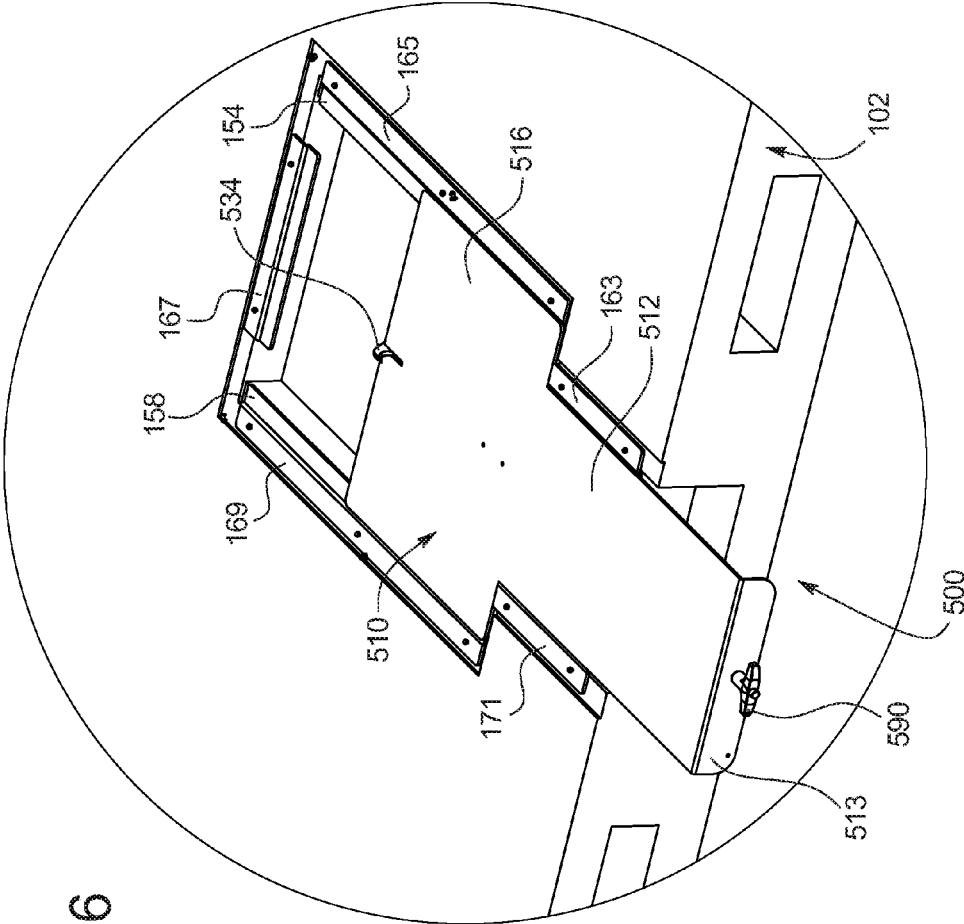

FIG. 16

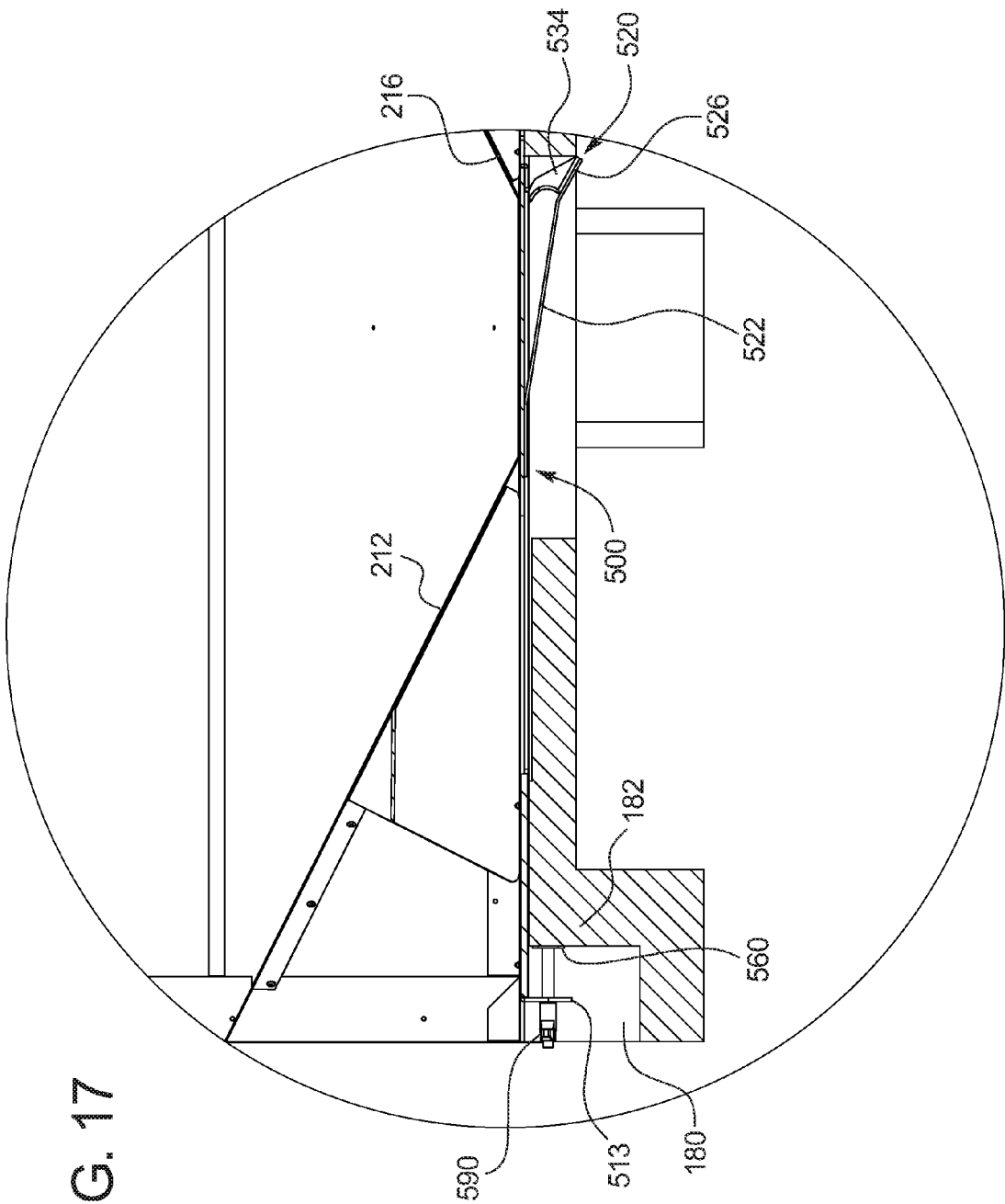

FIG. 17

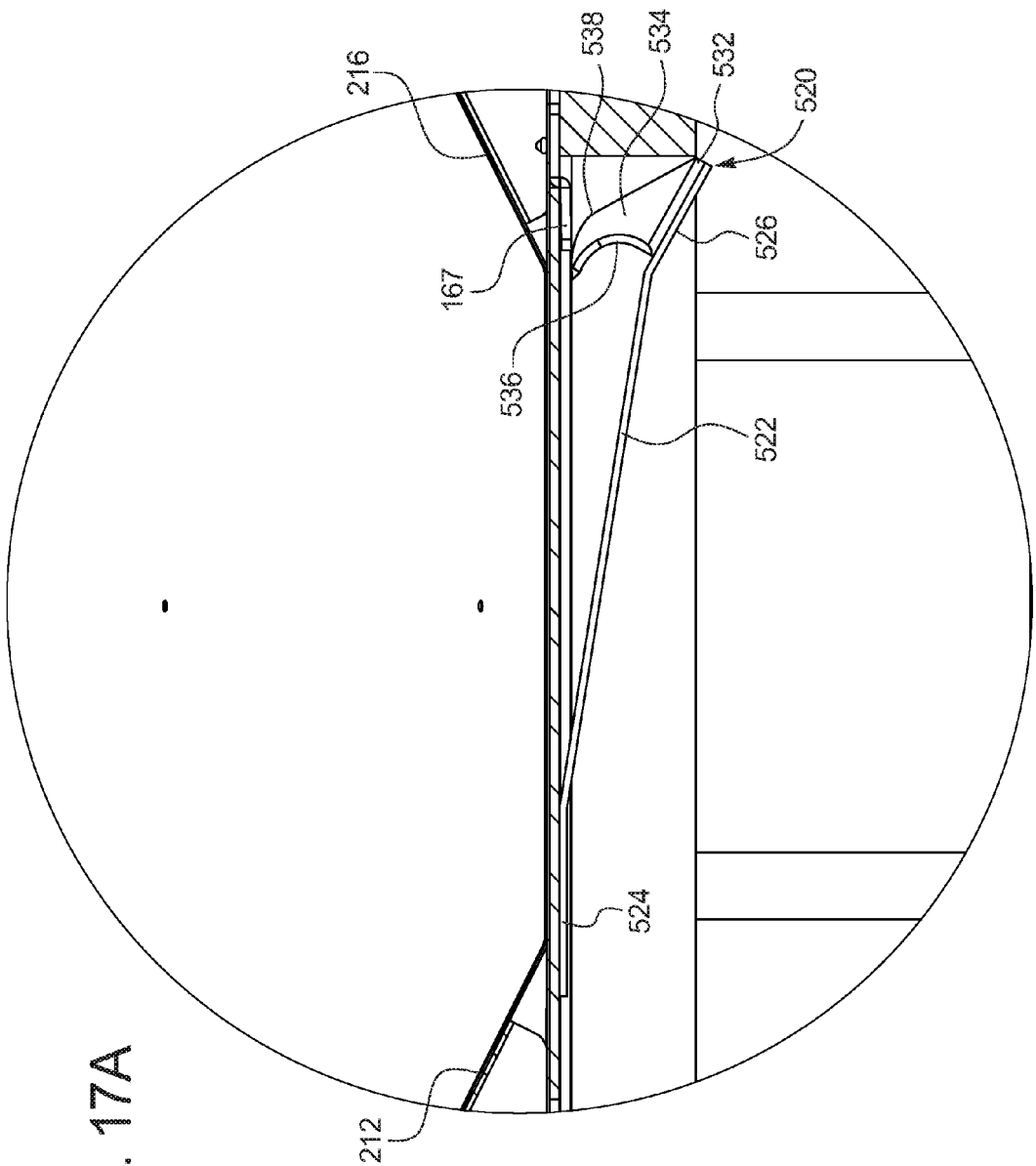
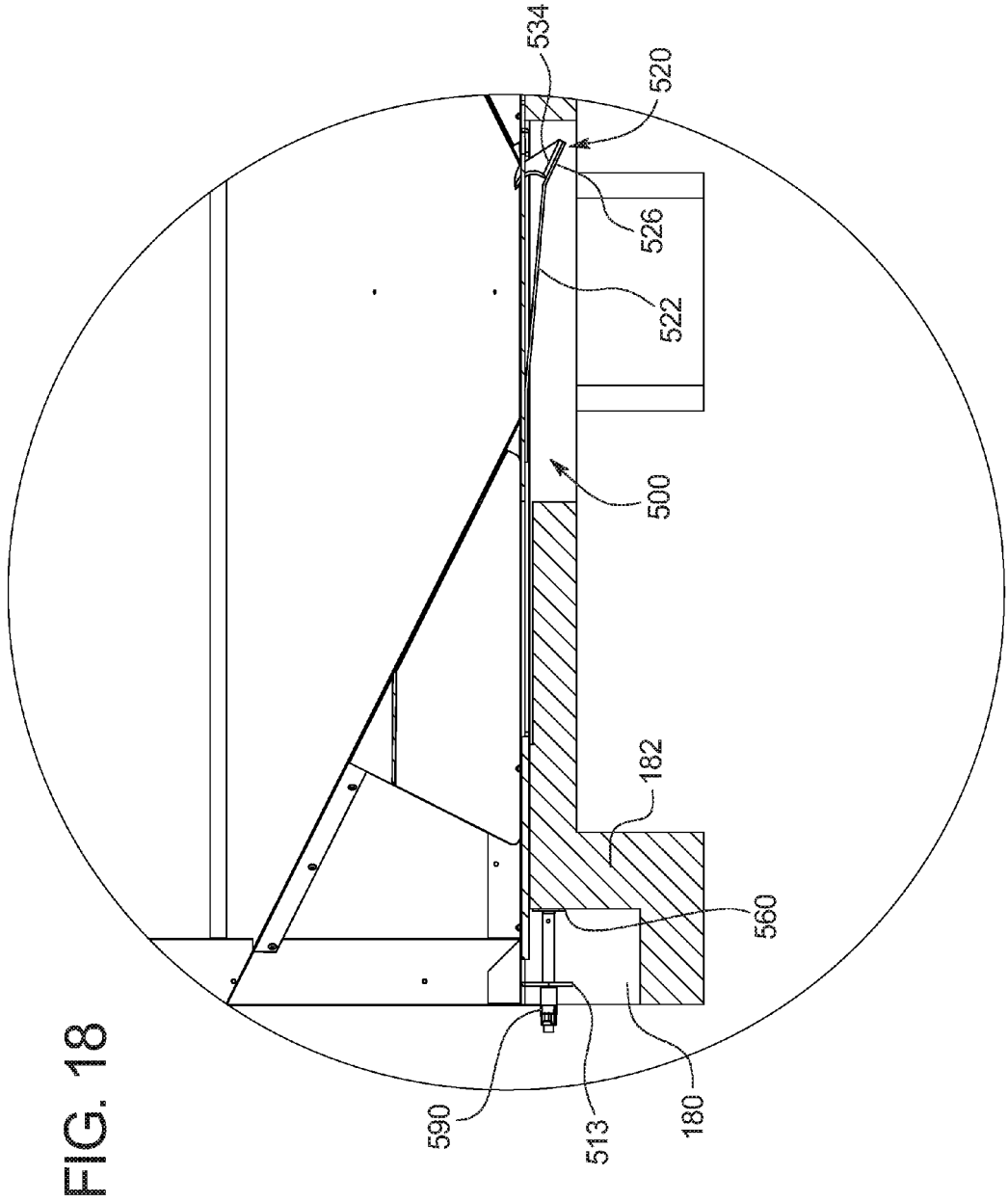

FIG. 17A



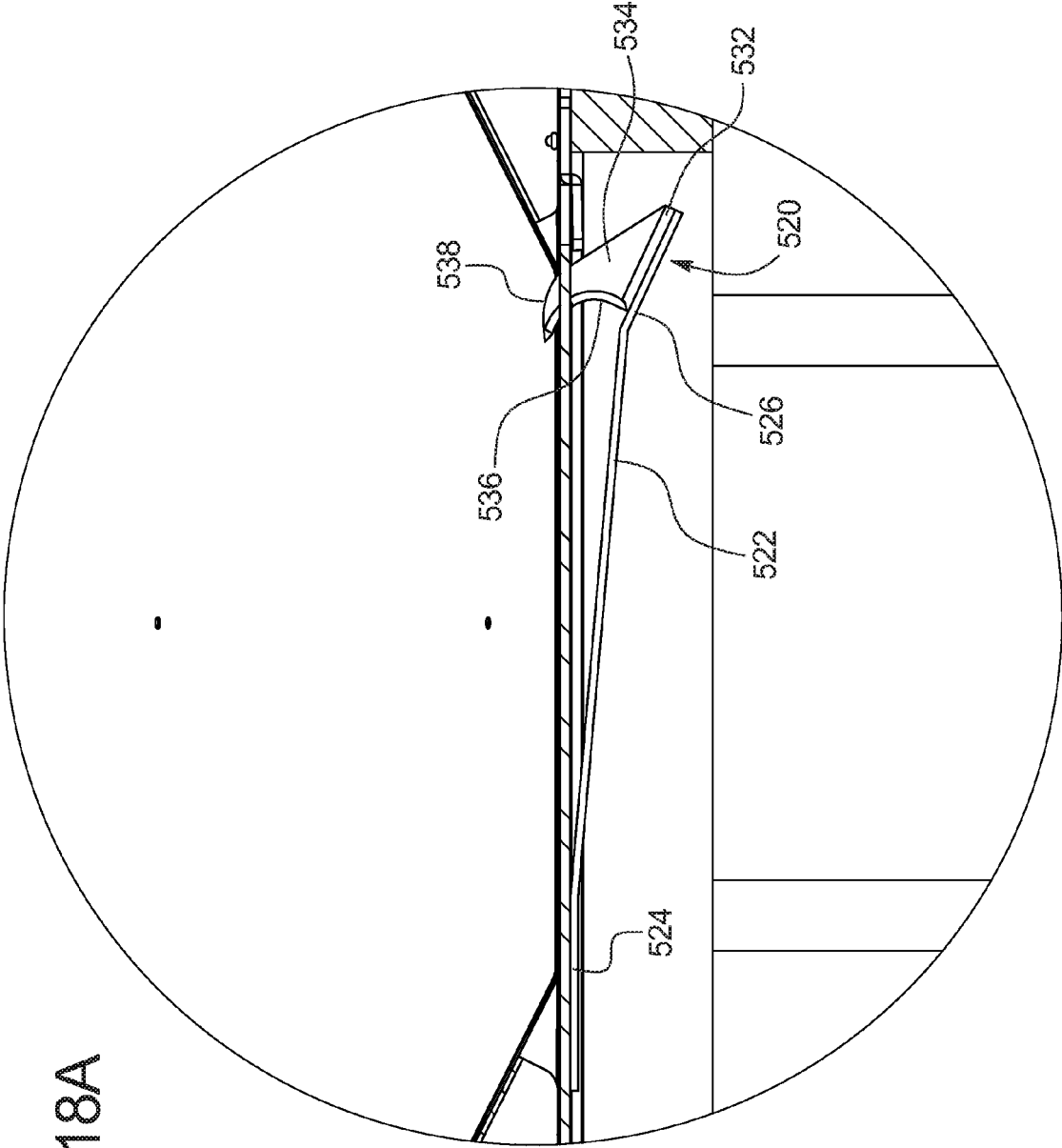
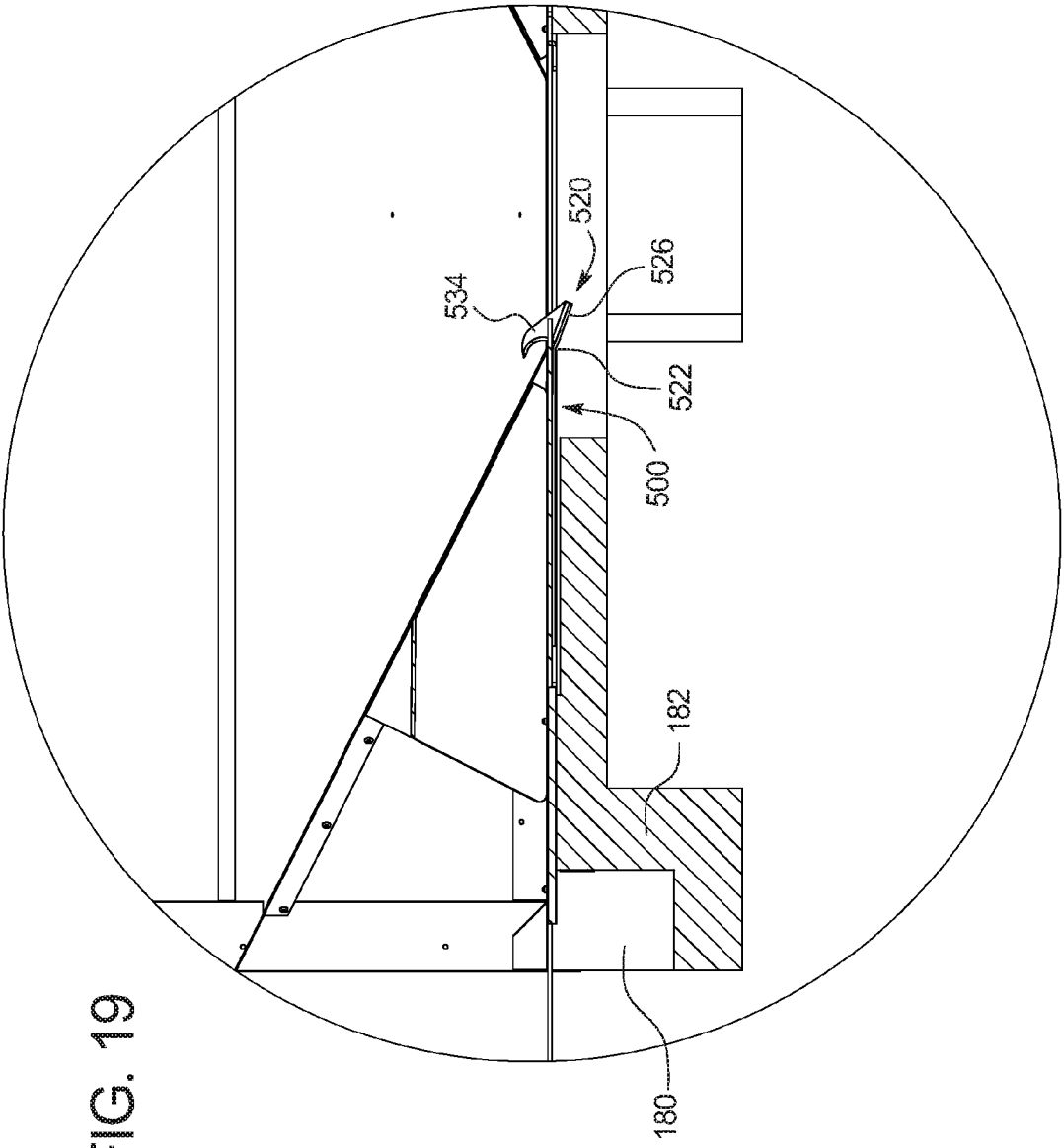

FIG. 18A



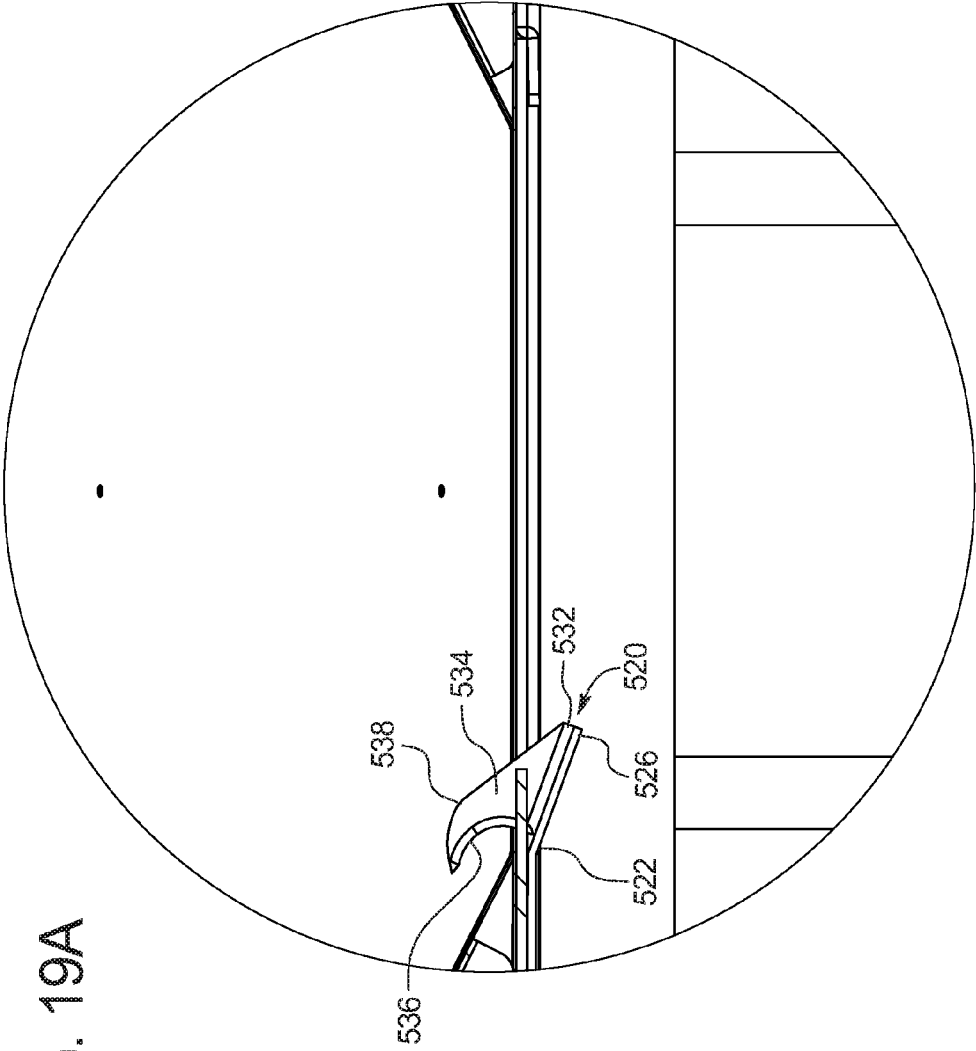

FIG. 19A

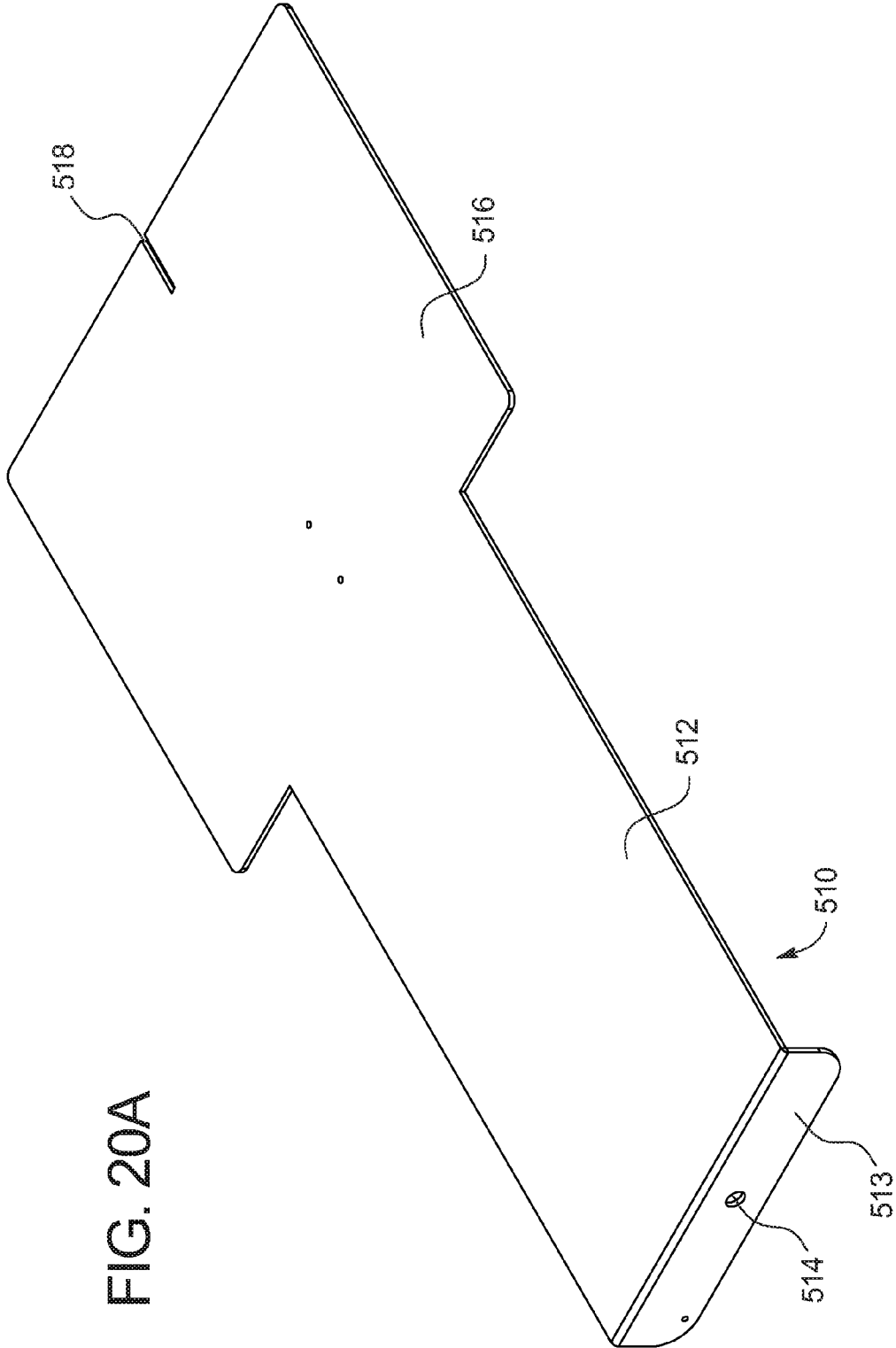

FIG. 20A

FIG. 20B

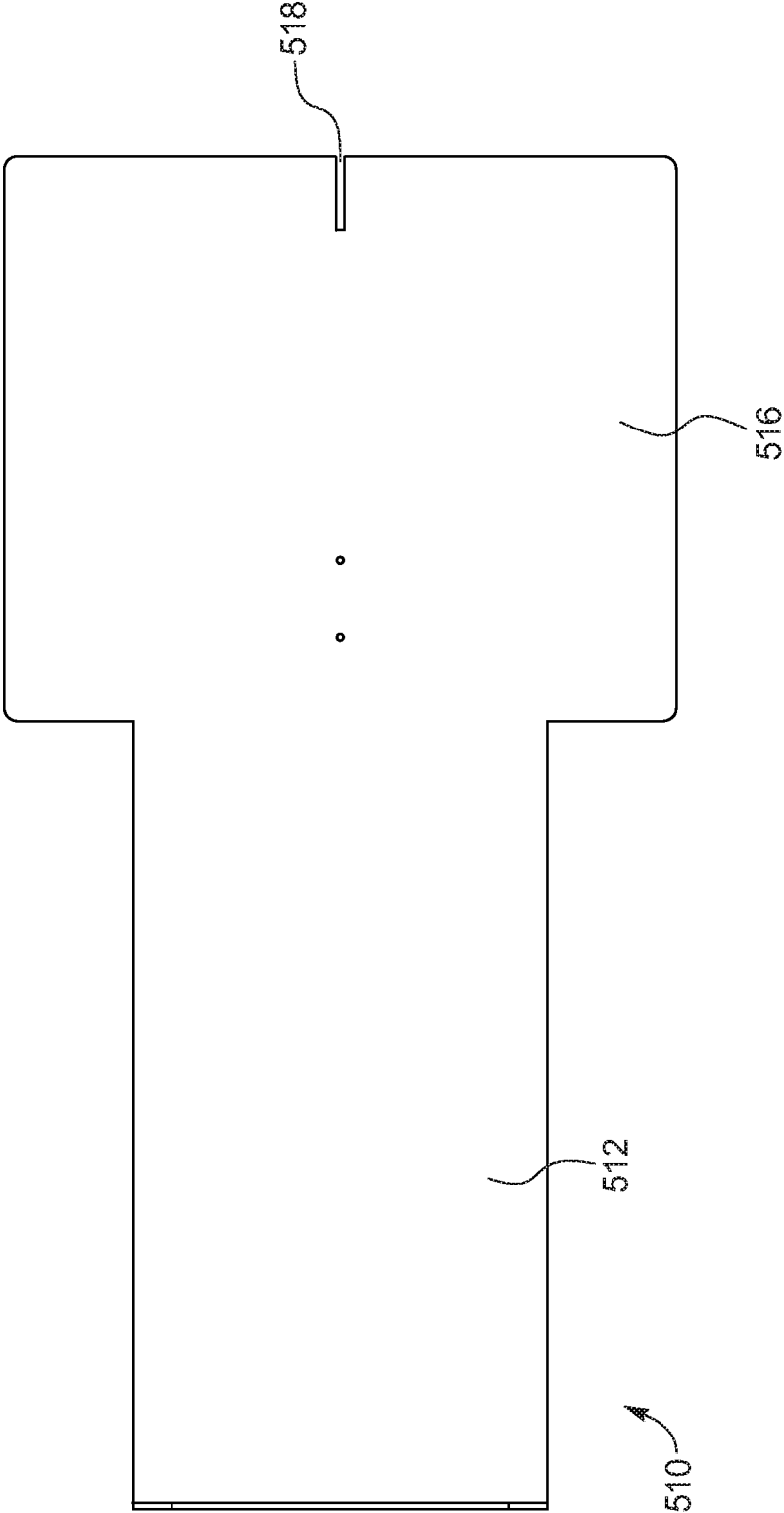

FIG. 20C

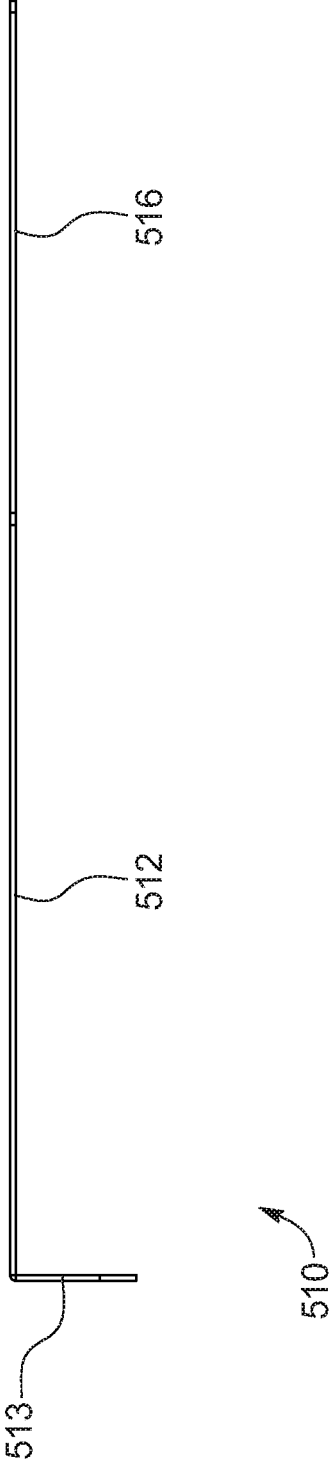
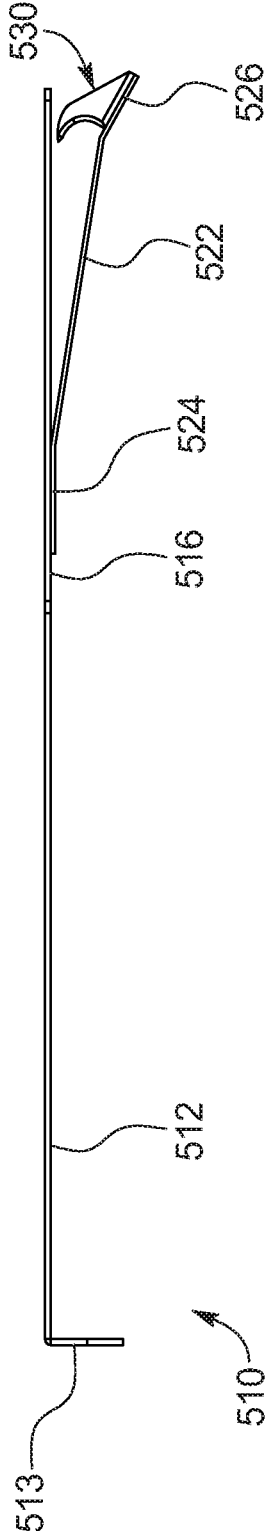

FIG. 20D



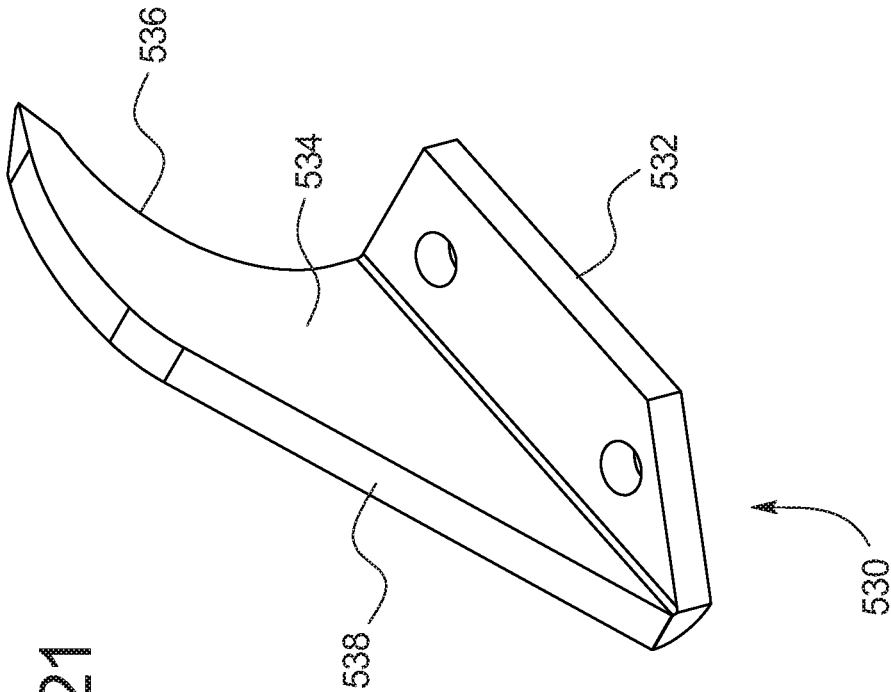

FIG. 21

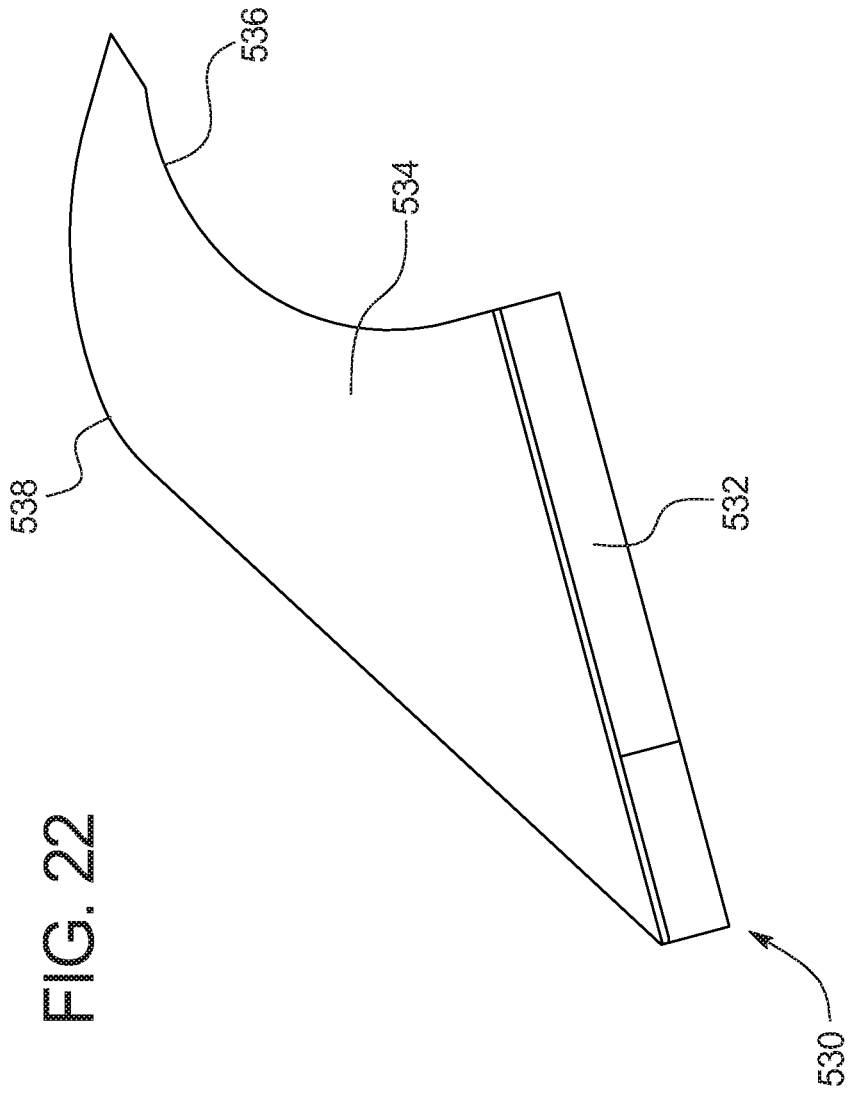

FIG. 23

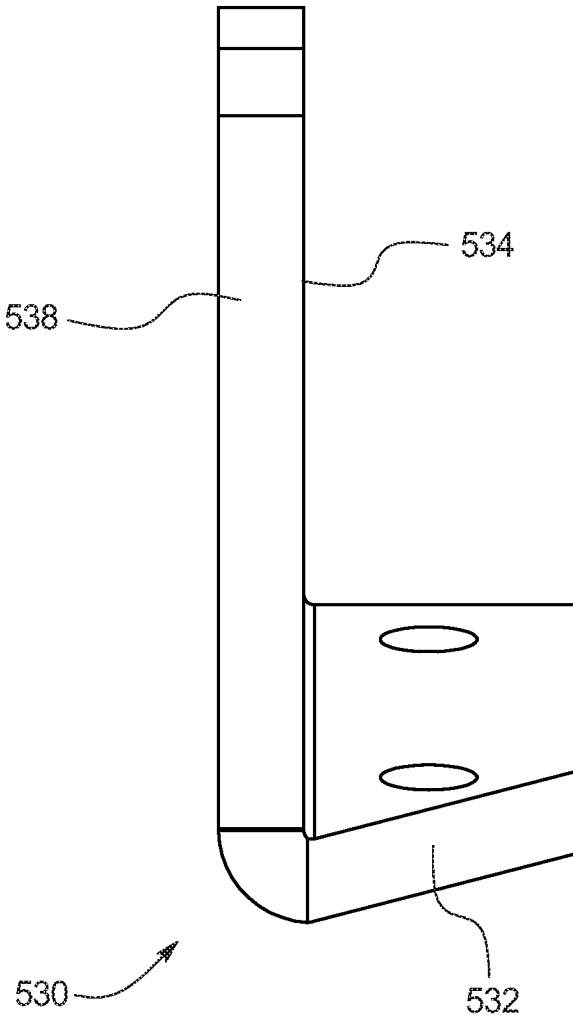
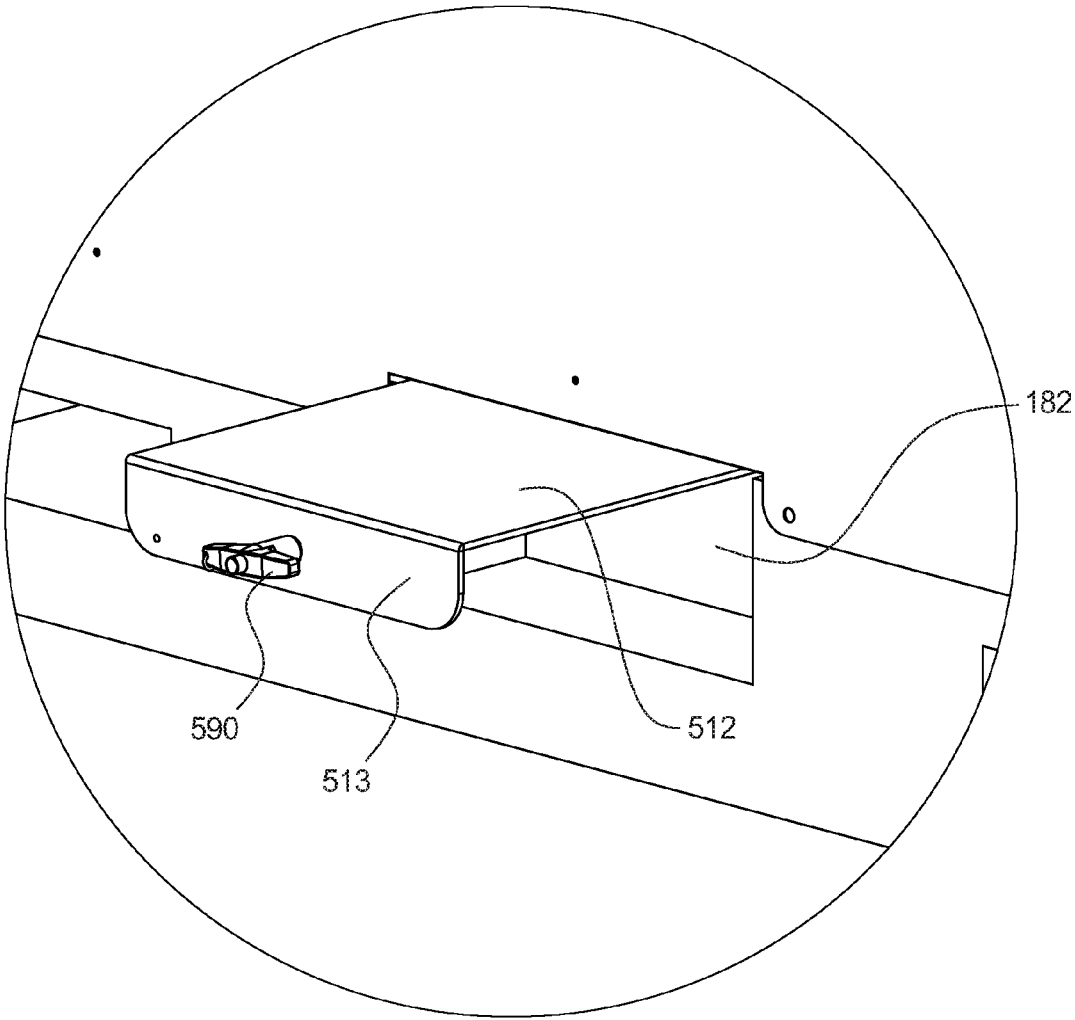

FIG. 24



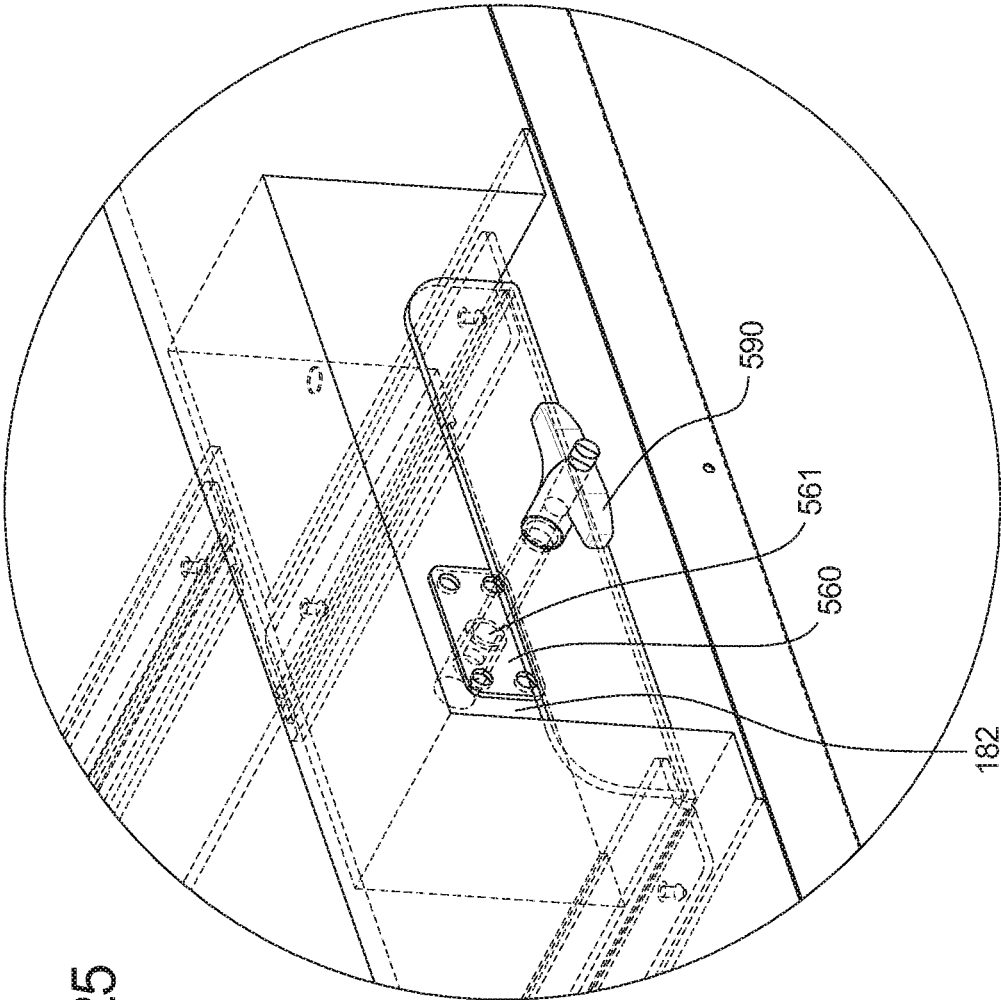

FIG. 25

FIG. 26

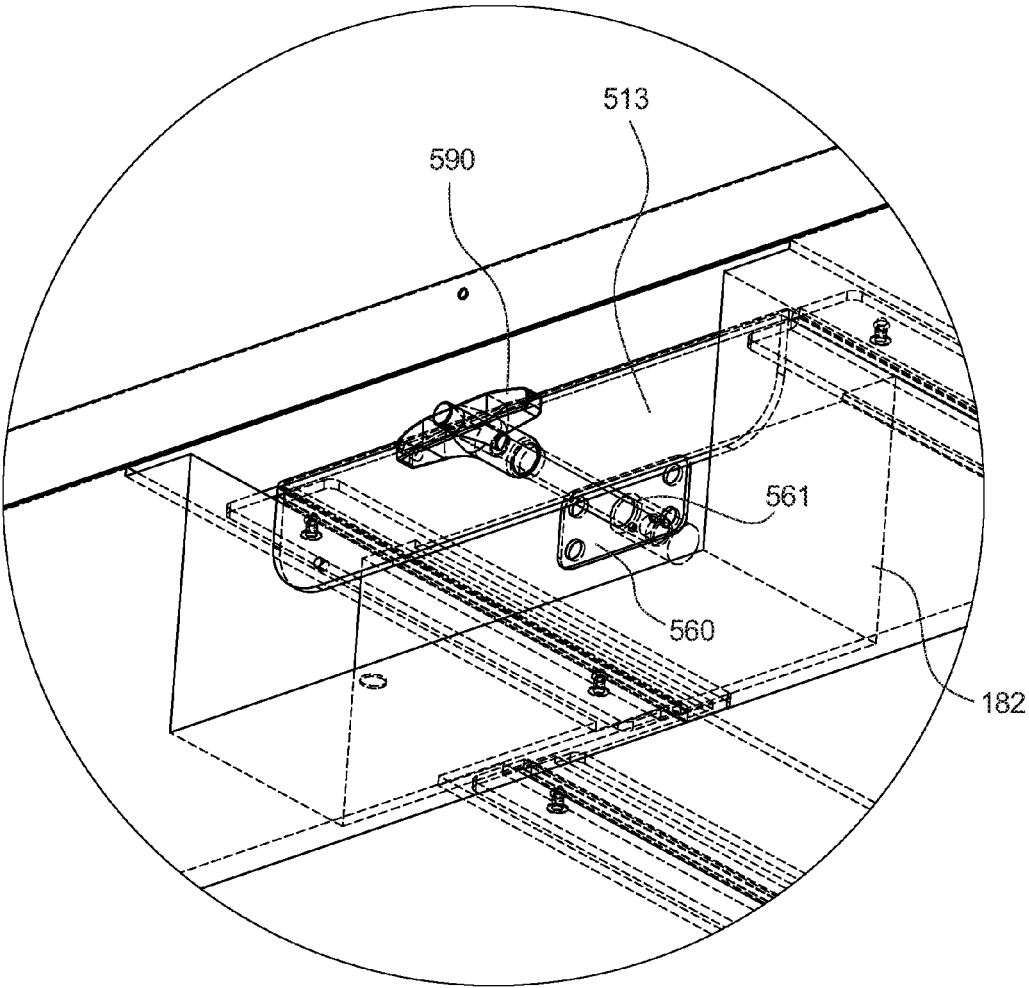

FIG. 27A

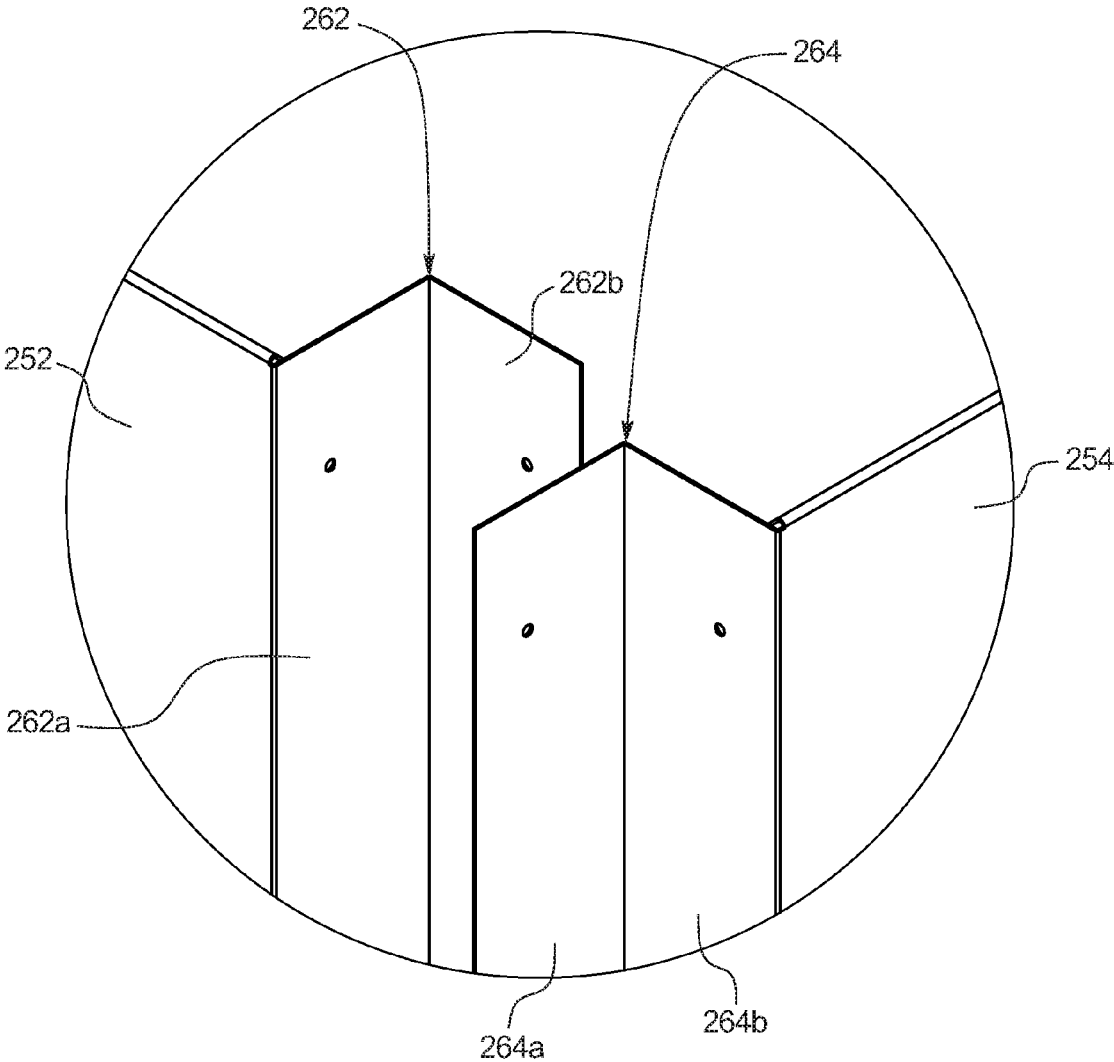

FIG. 27B

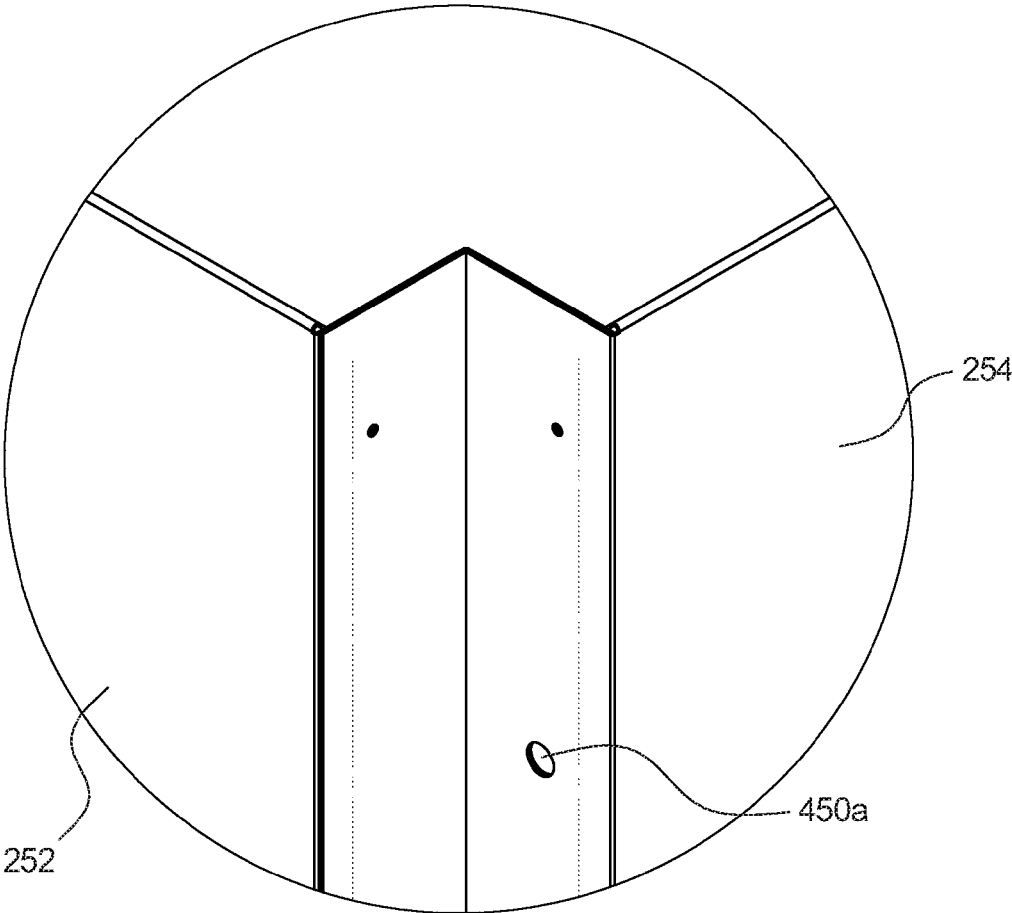

FIG. 27C

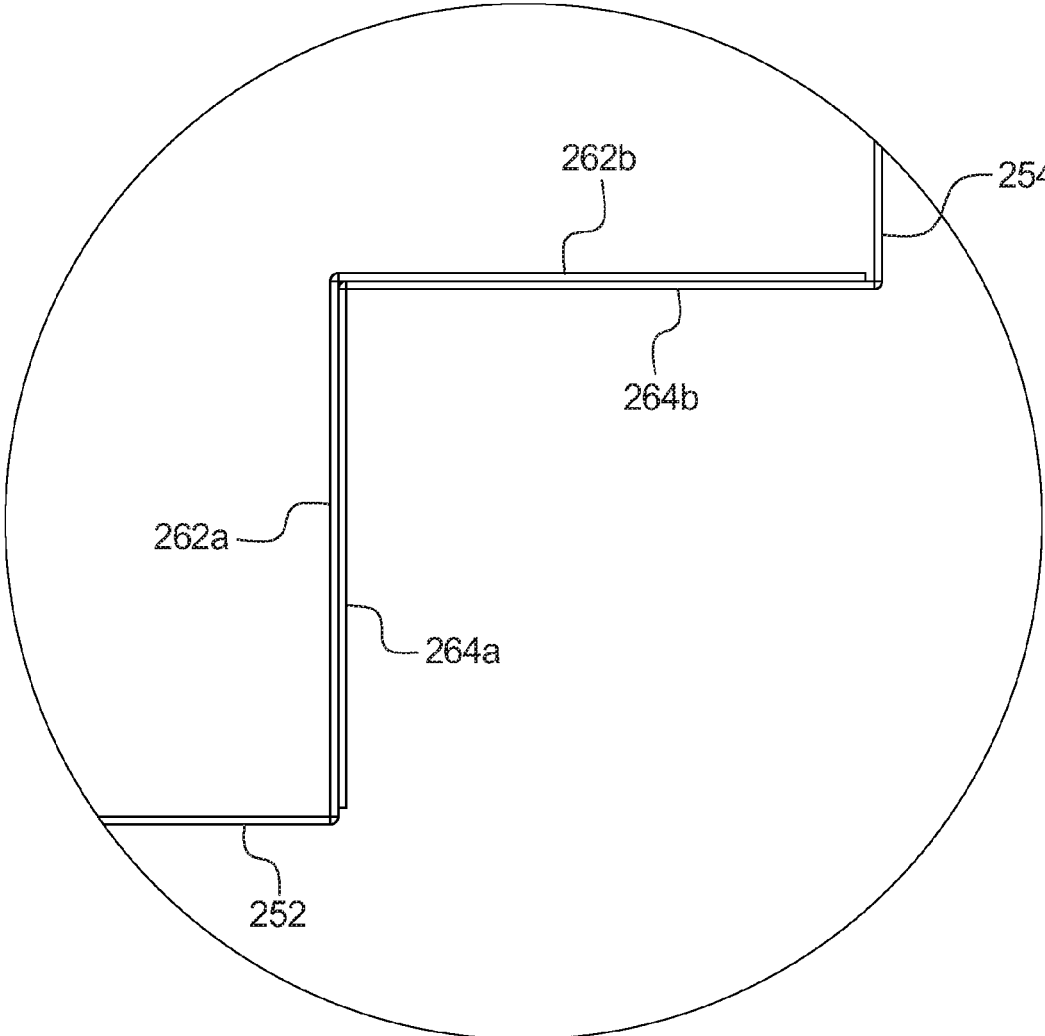

FIG. 28

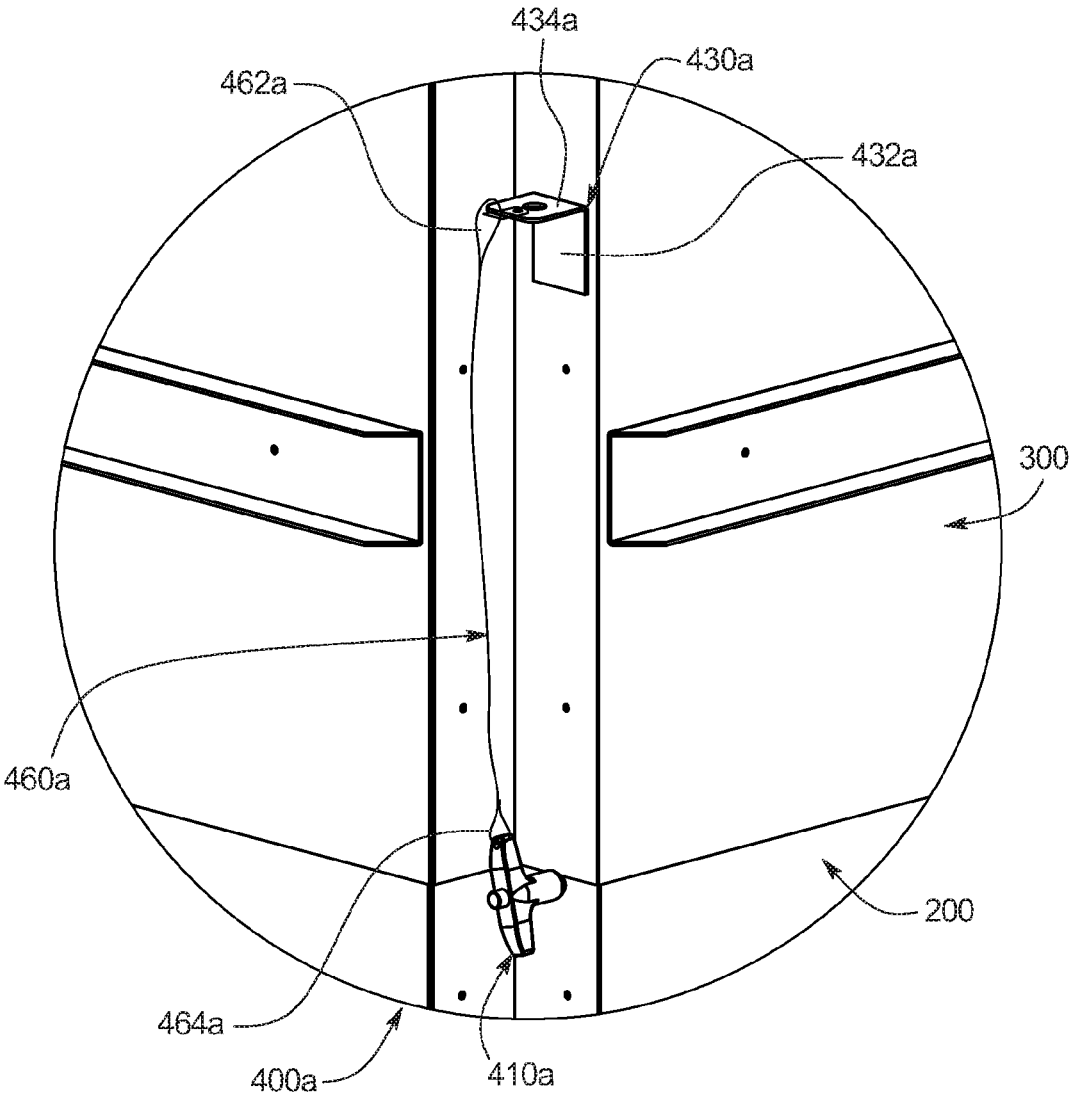

FIG. 29

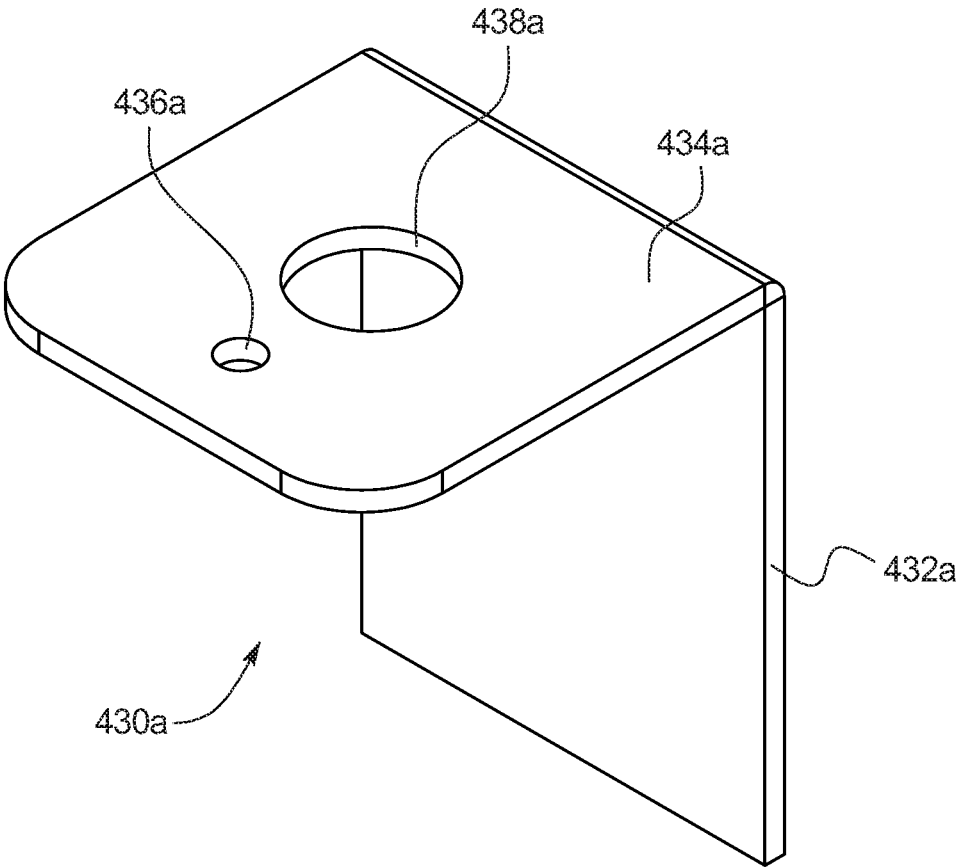
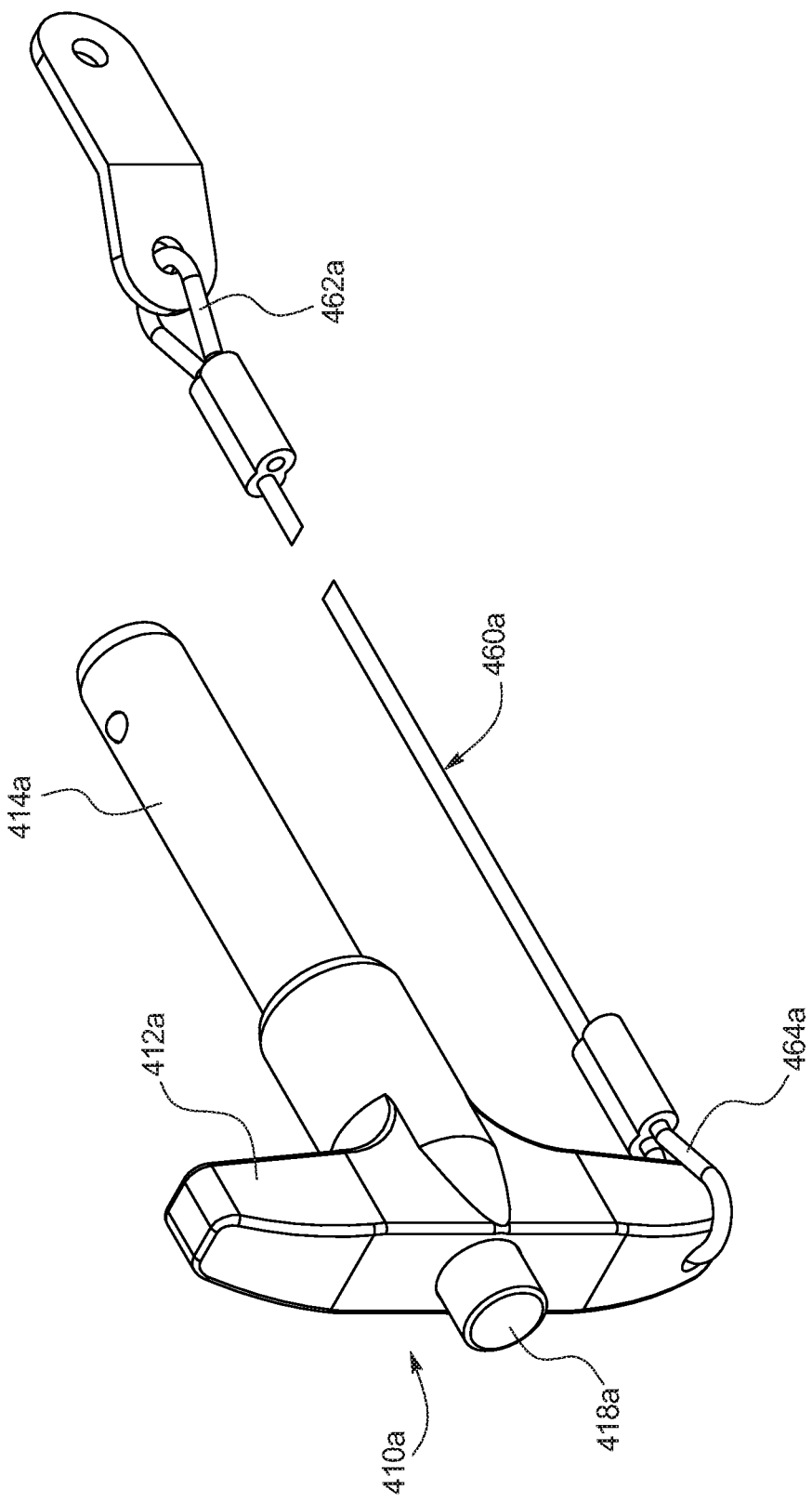

FIG. 30



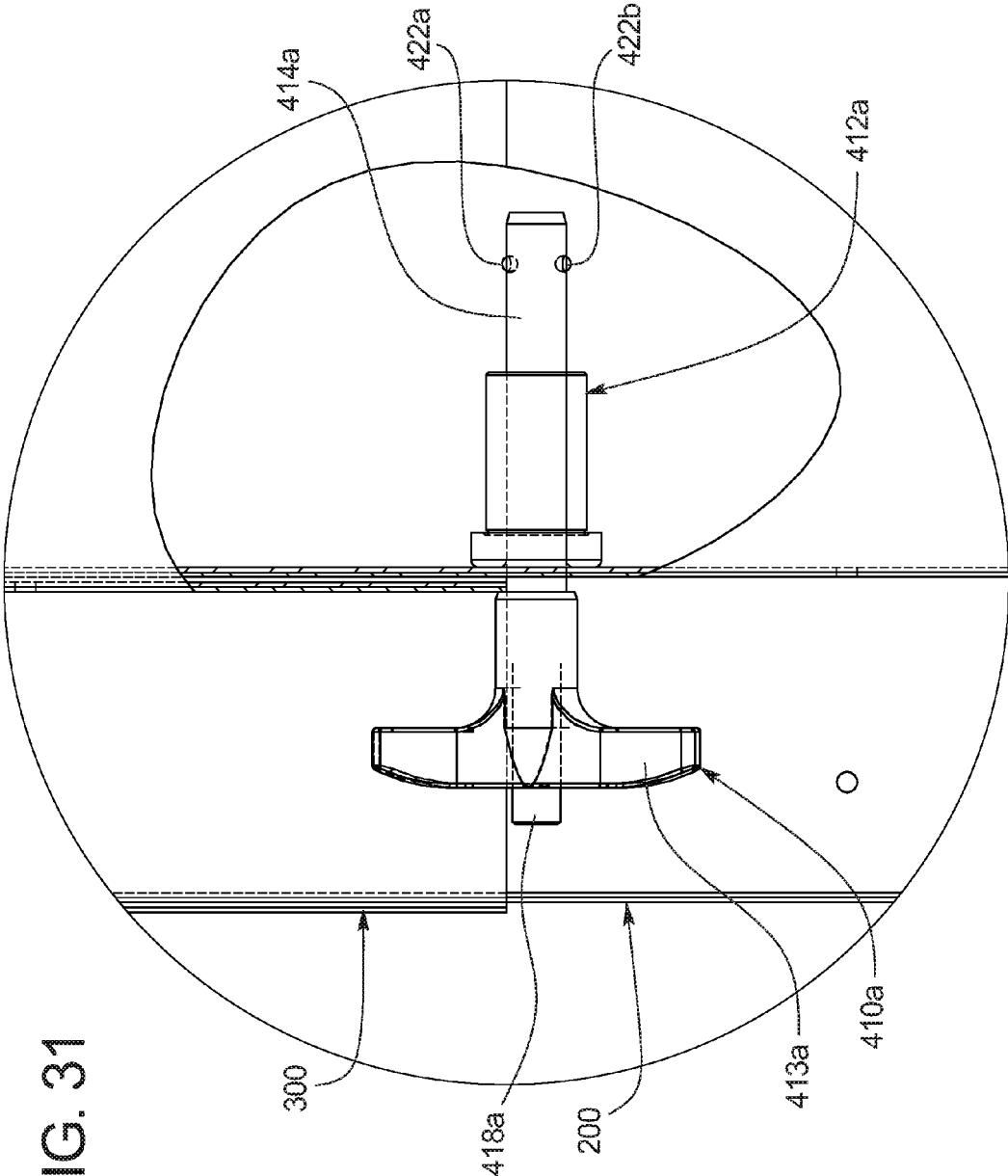

FIG. 31

FIG. 32

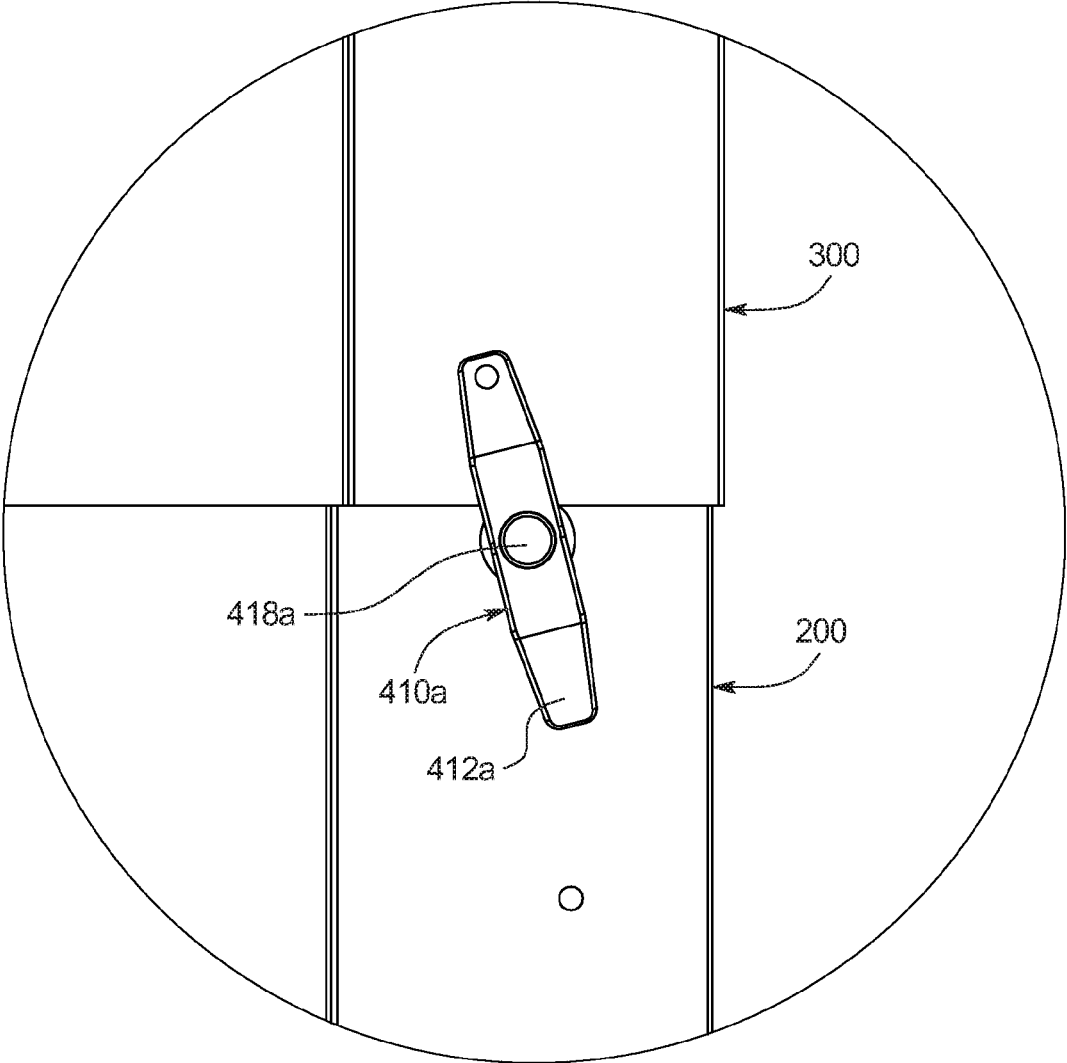

FIG. 33

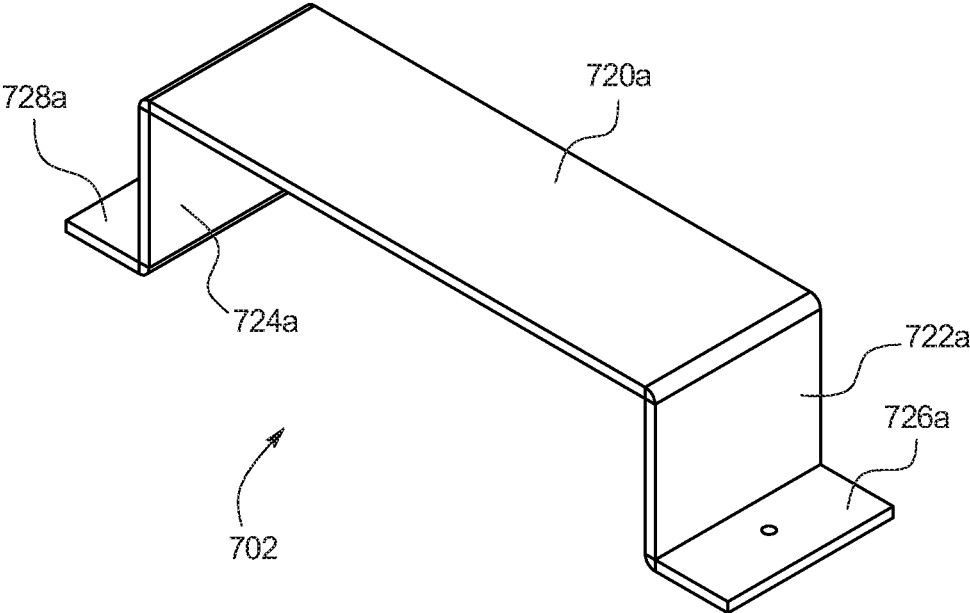
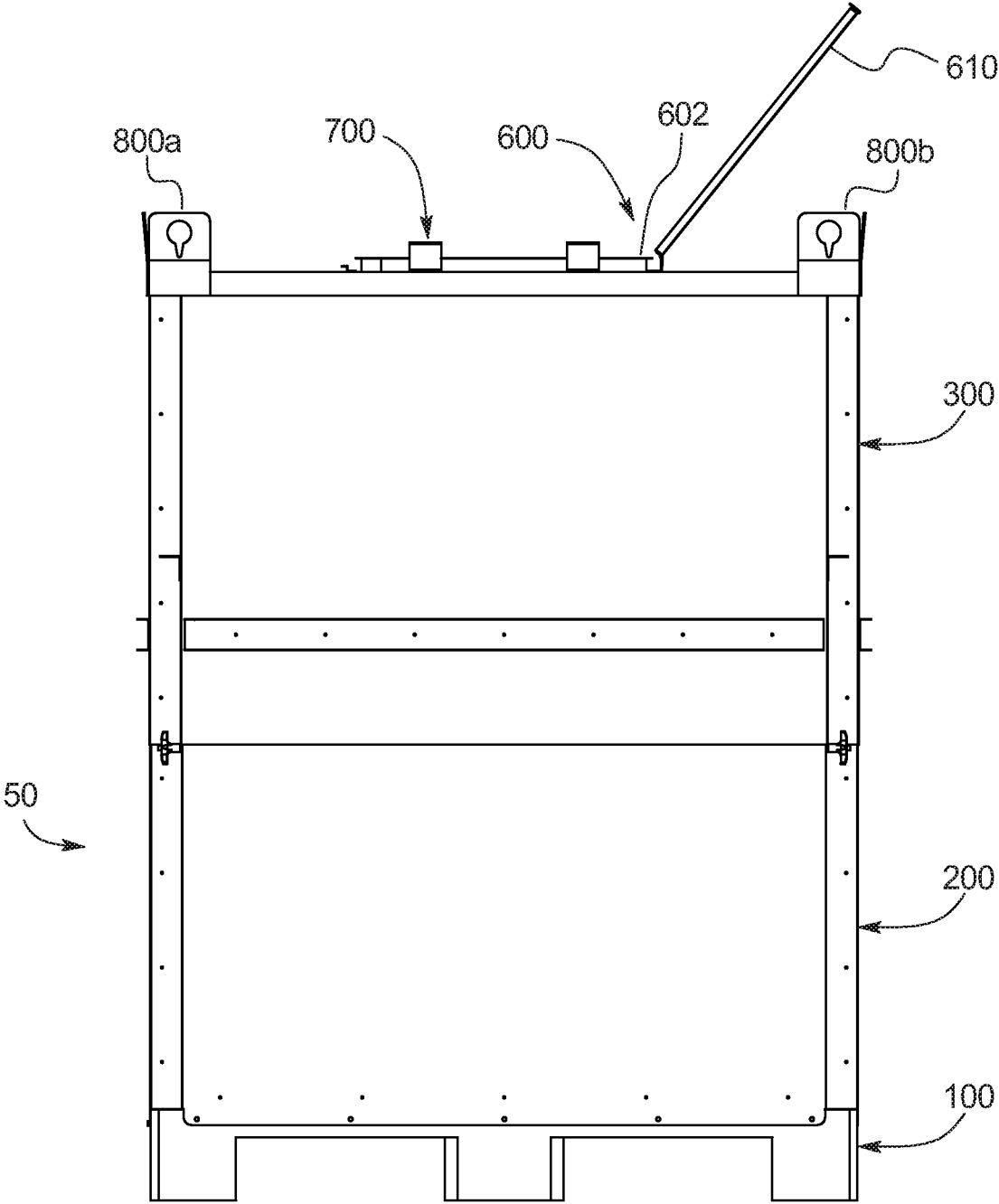
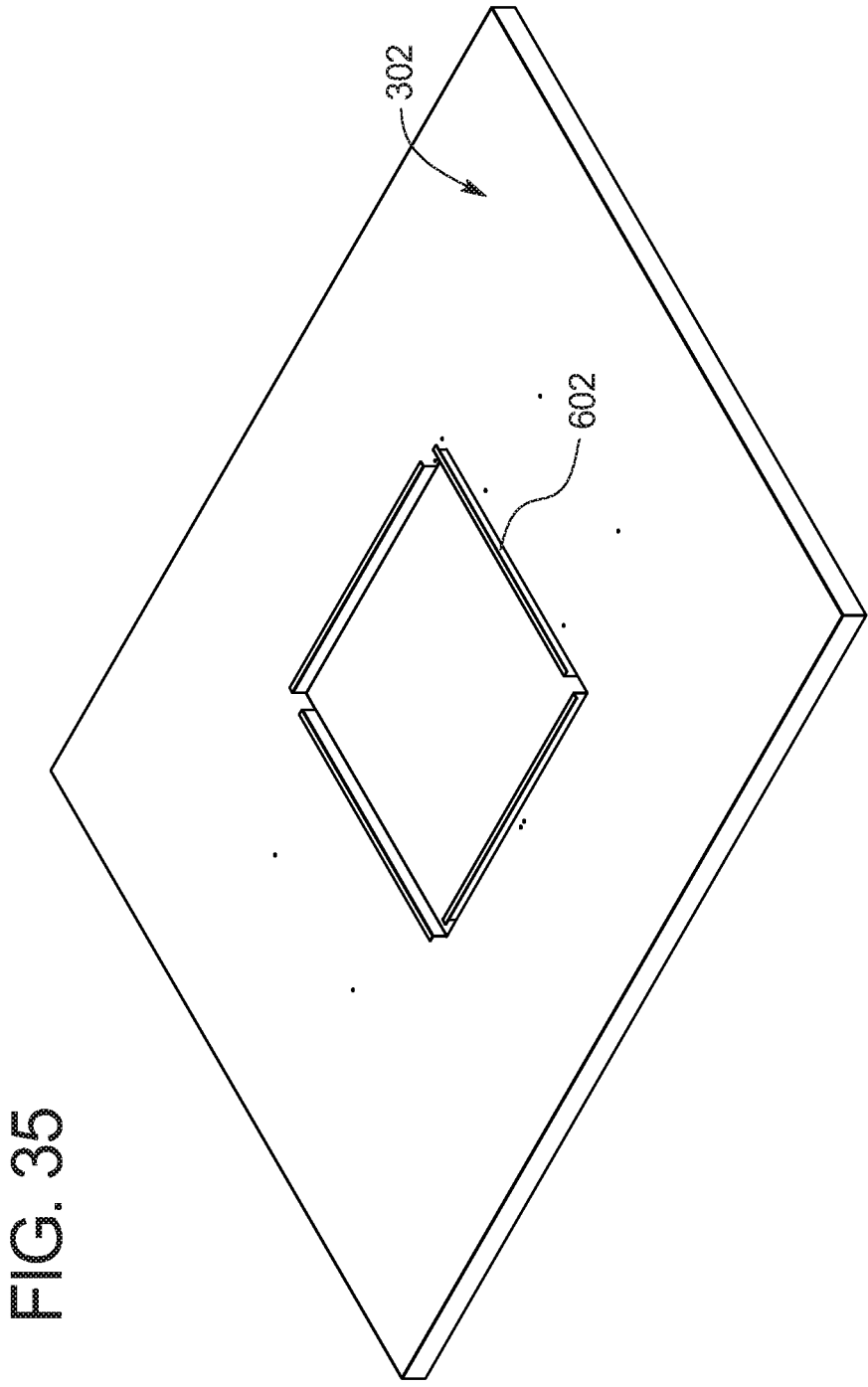

FIG. 34





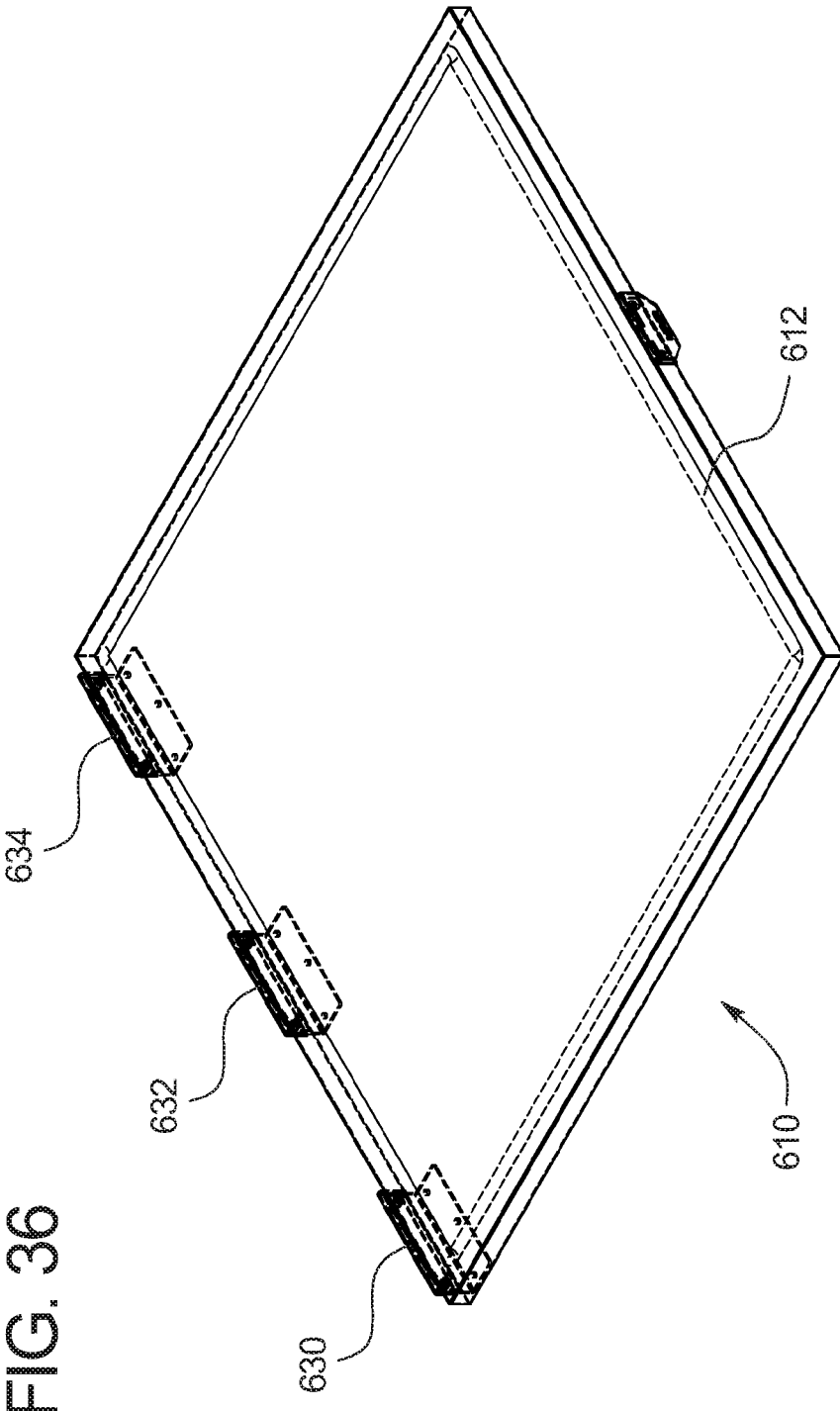

FIG. 36

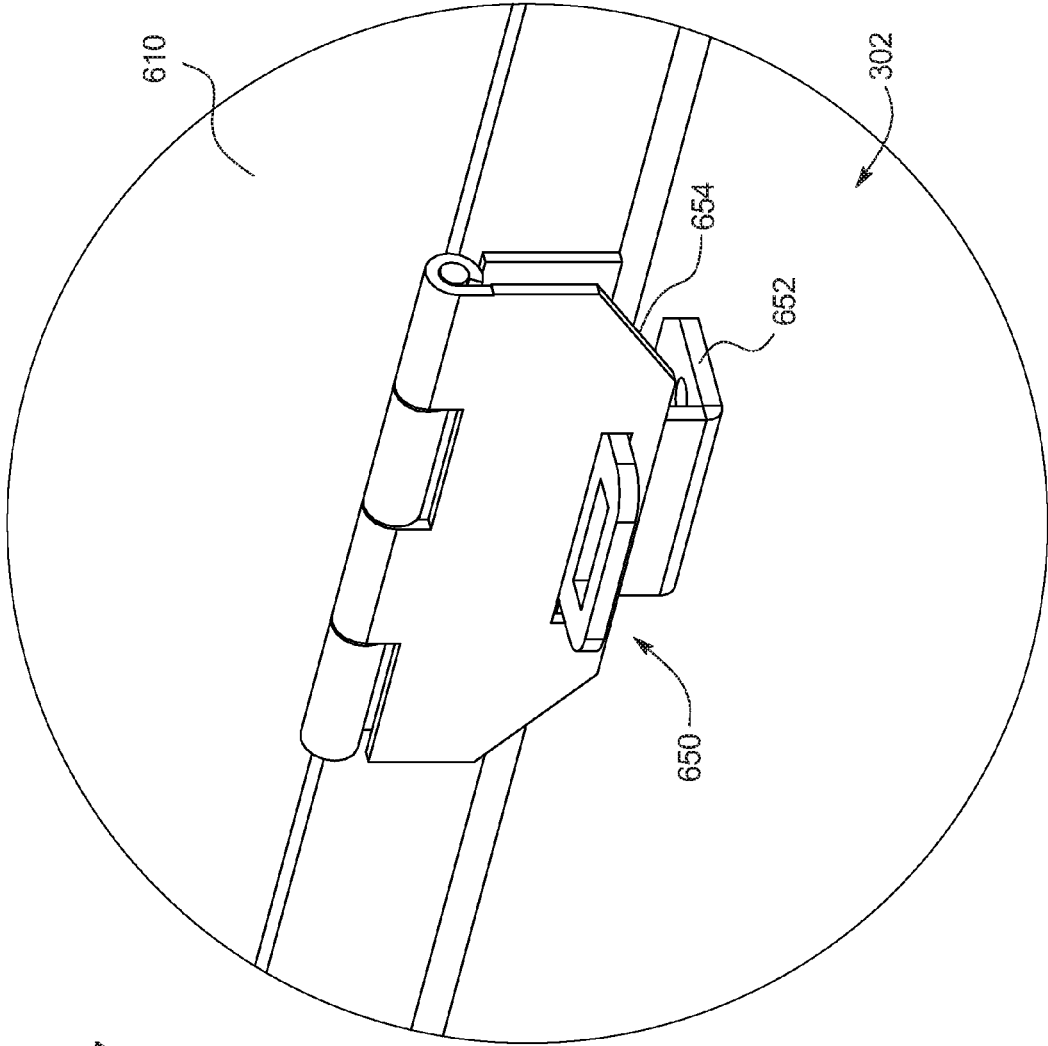
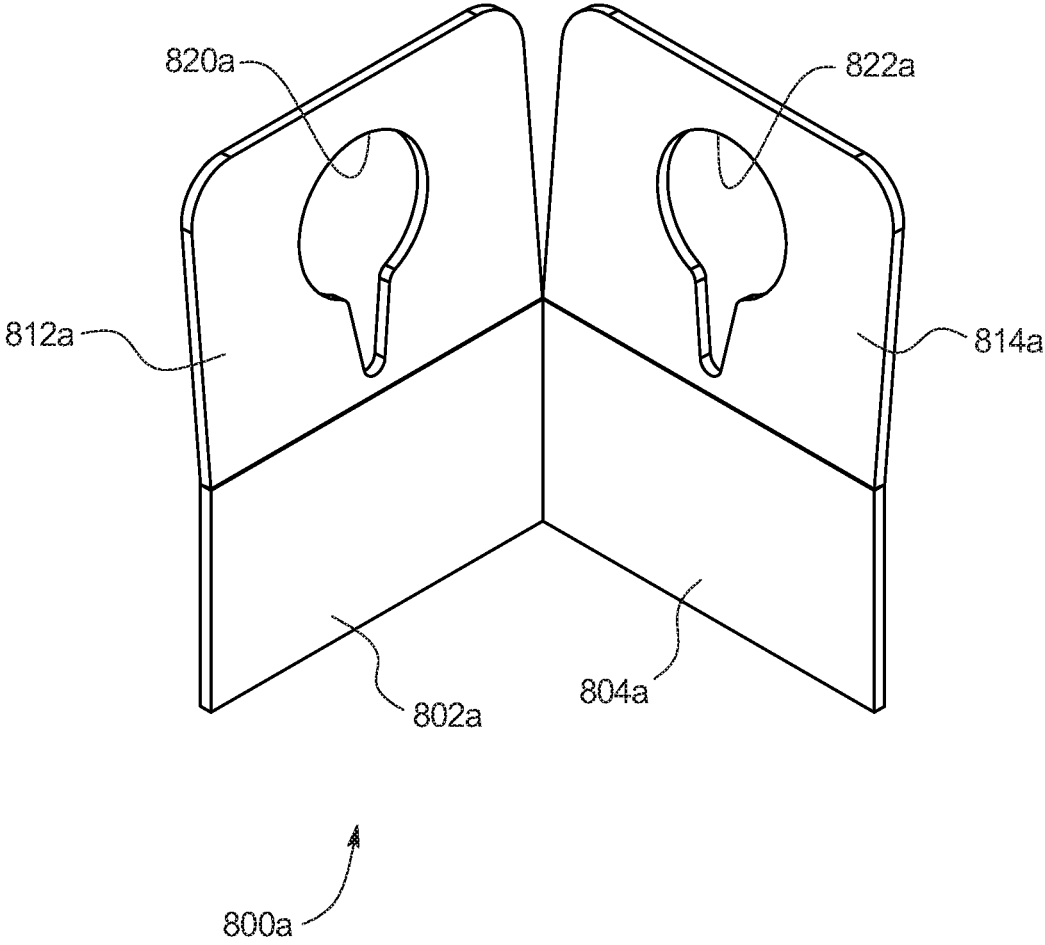

FIG. 37

FIG. 38



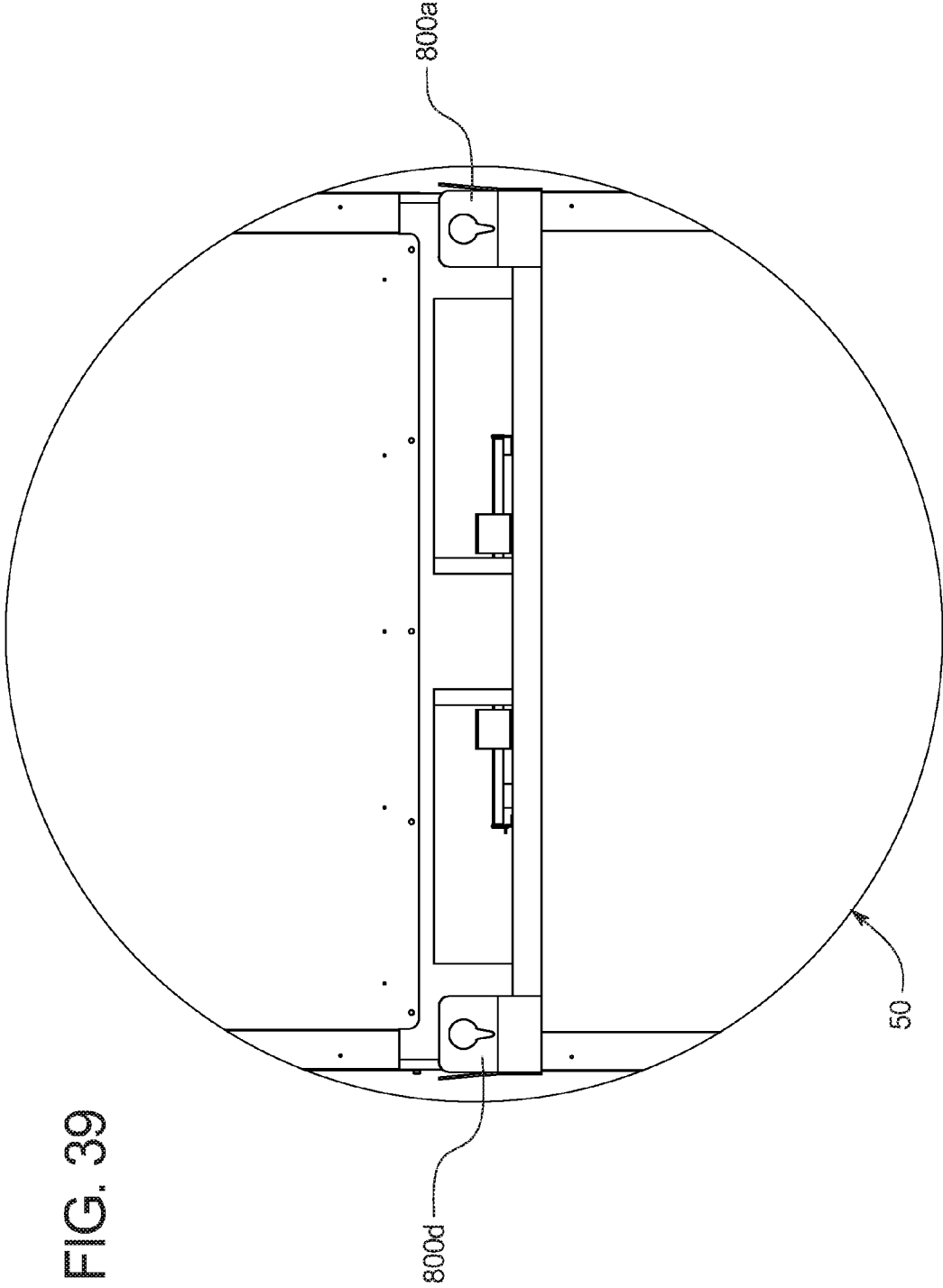

FIG. 39

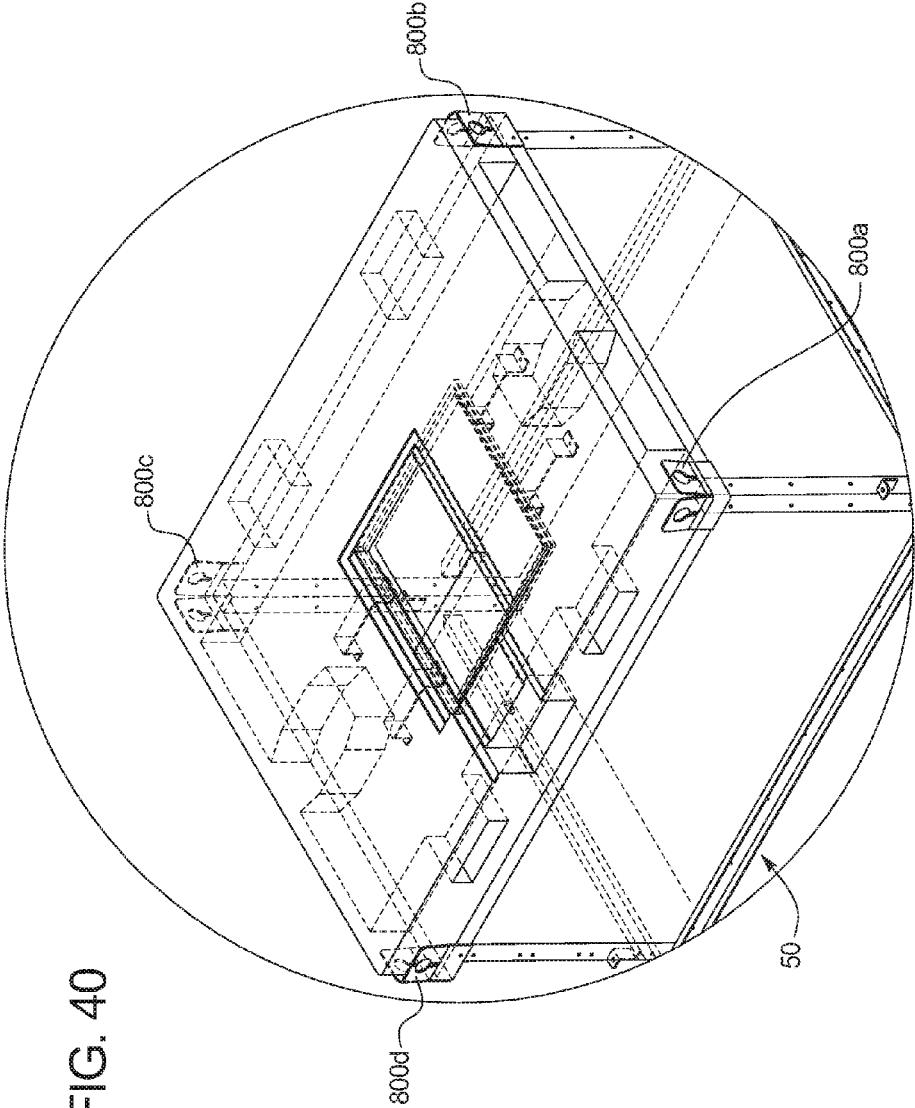

FIG. 41

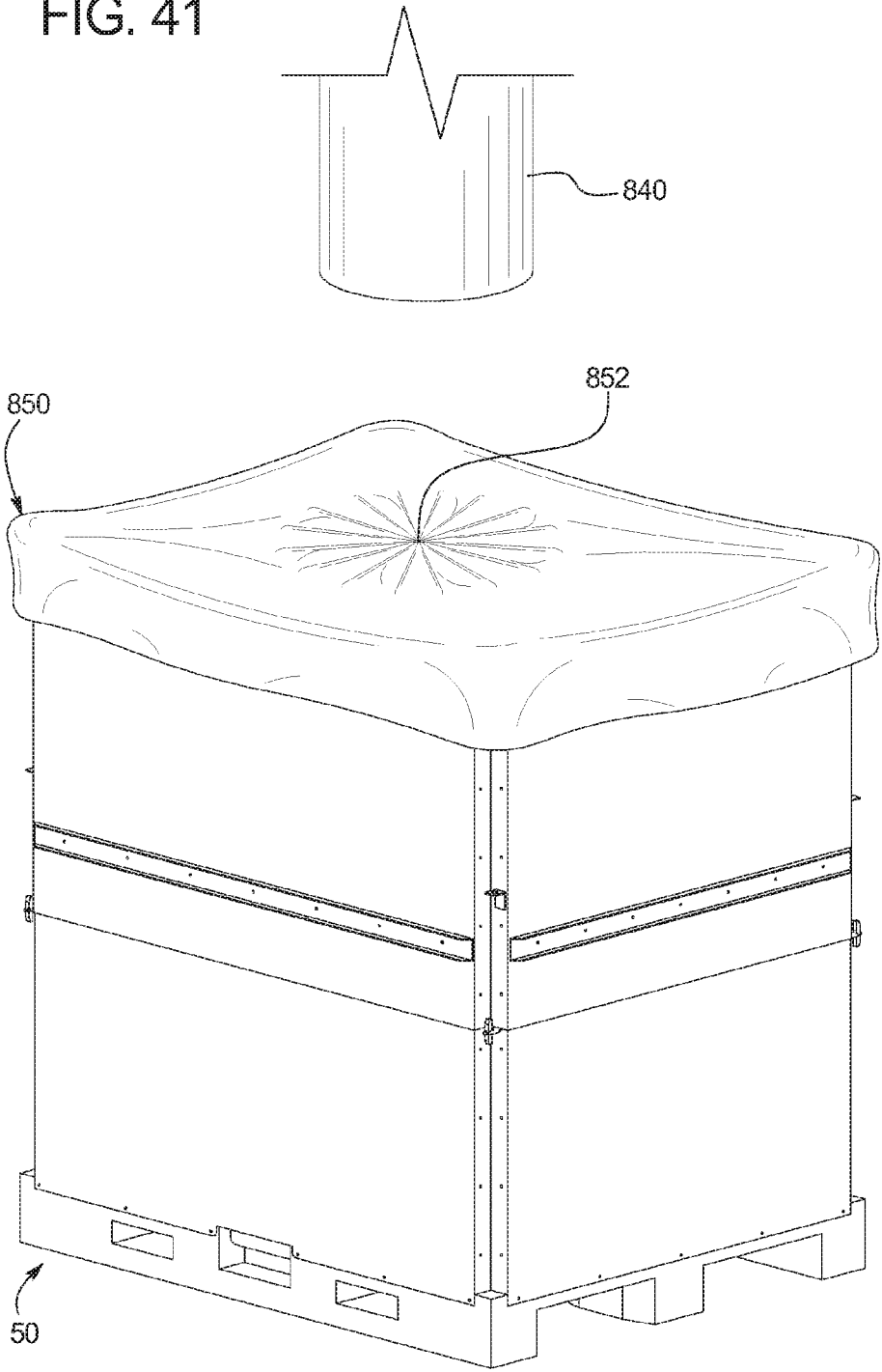
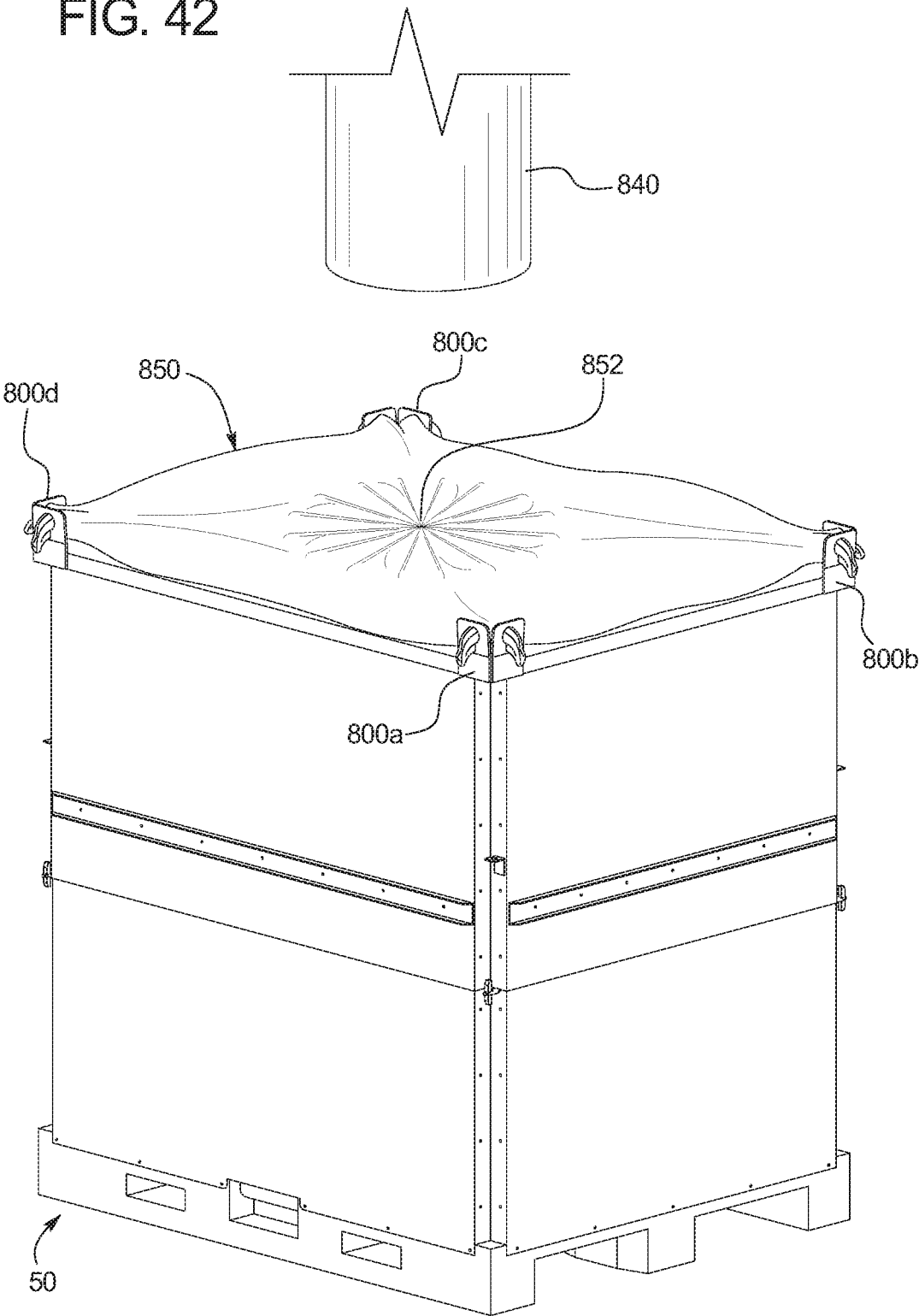

FIG. 42



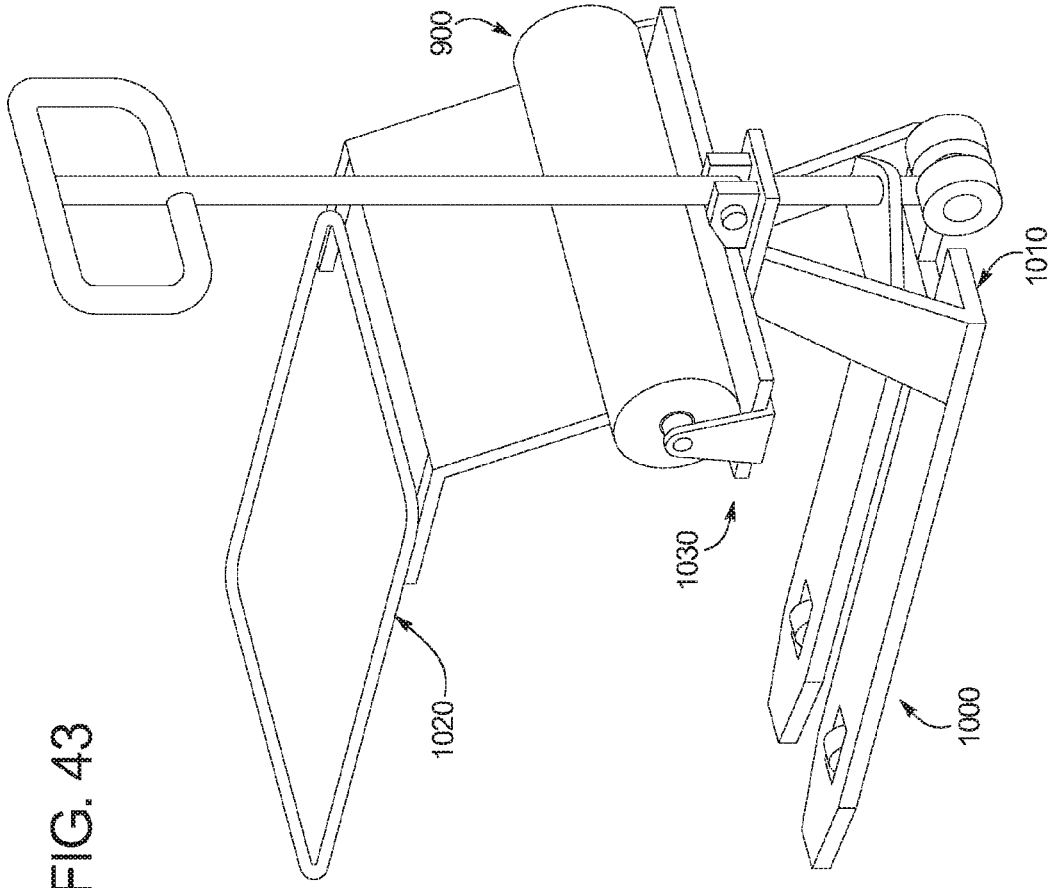
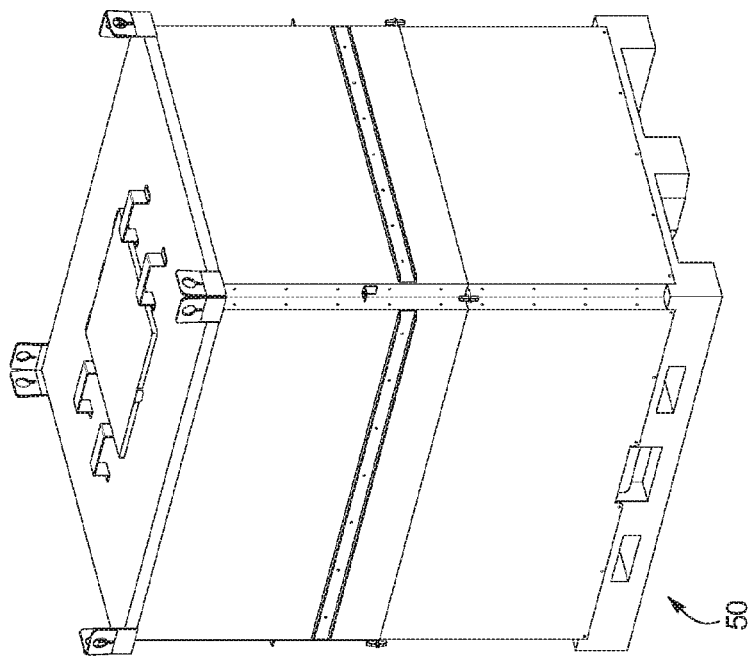
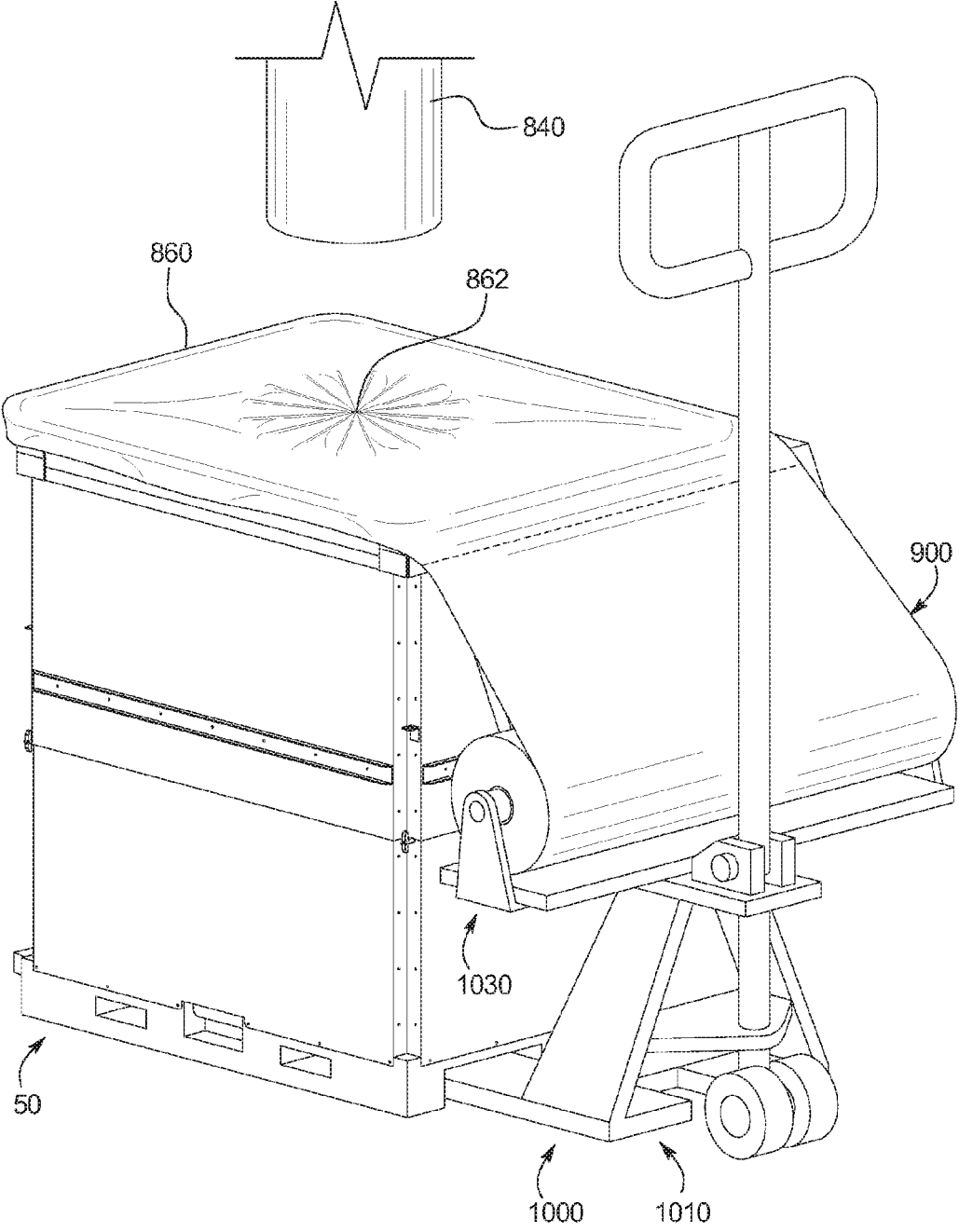

FIG. 43



50

FIG. 44



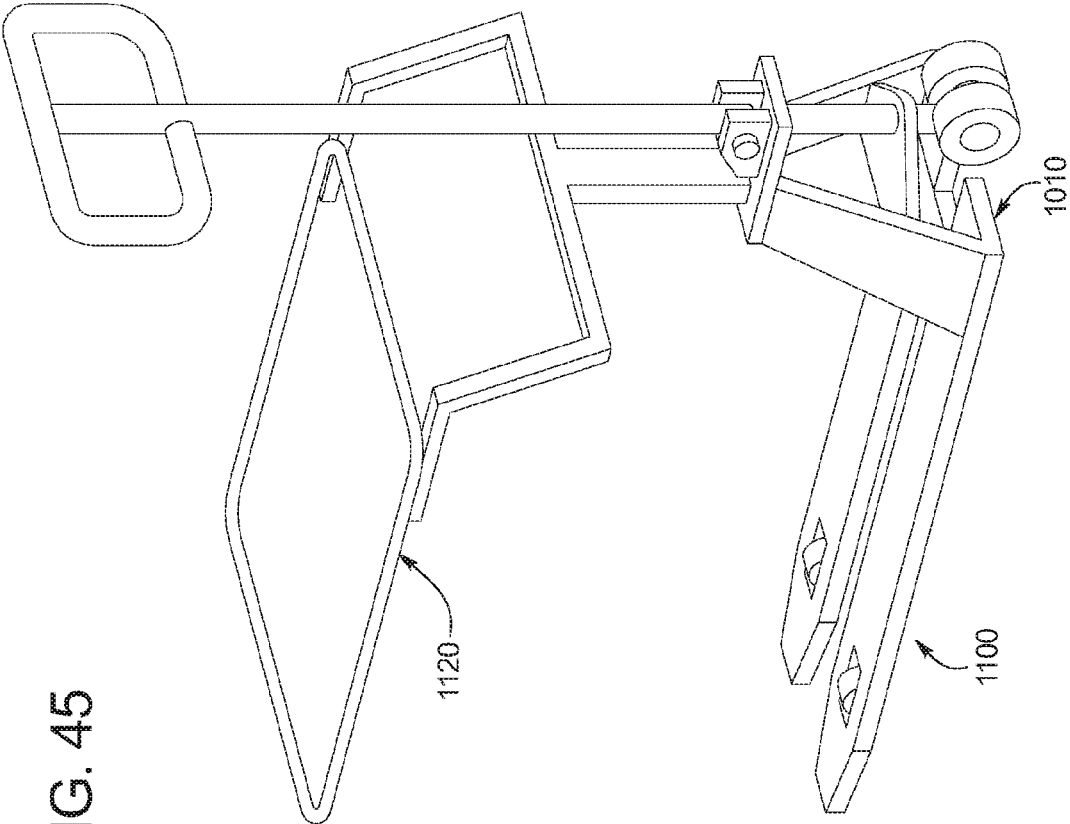
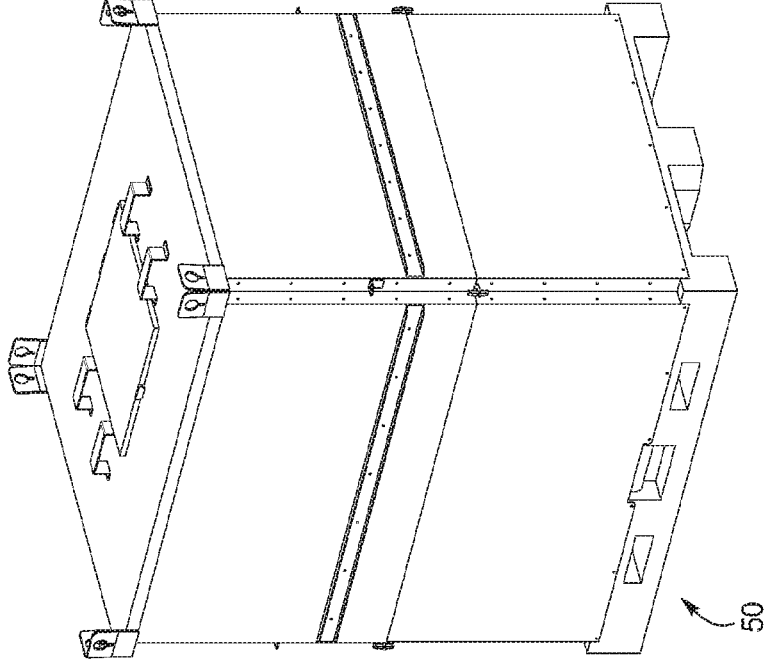

FIG. 45



50

FIG. 46

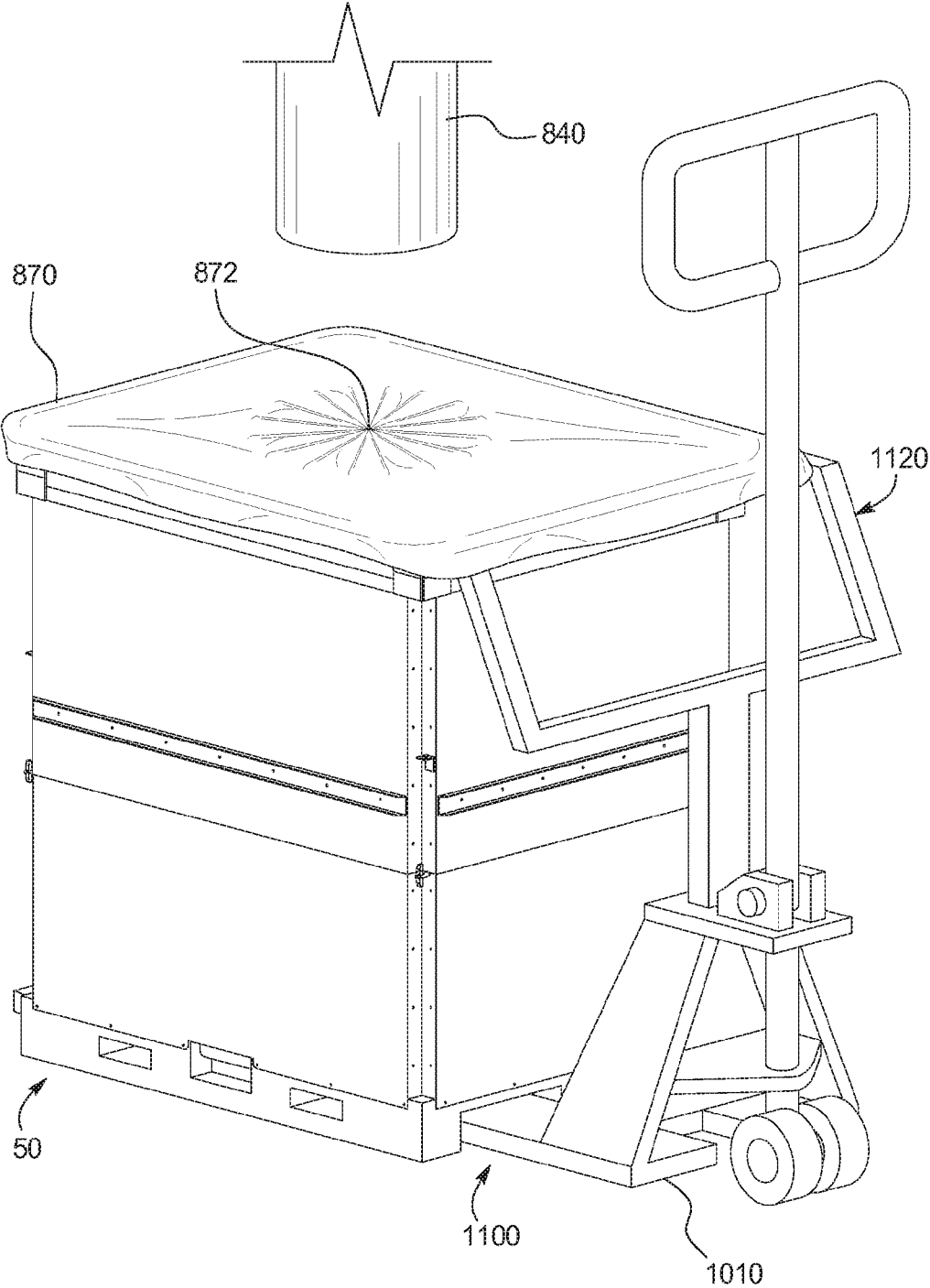
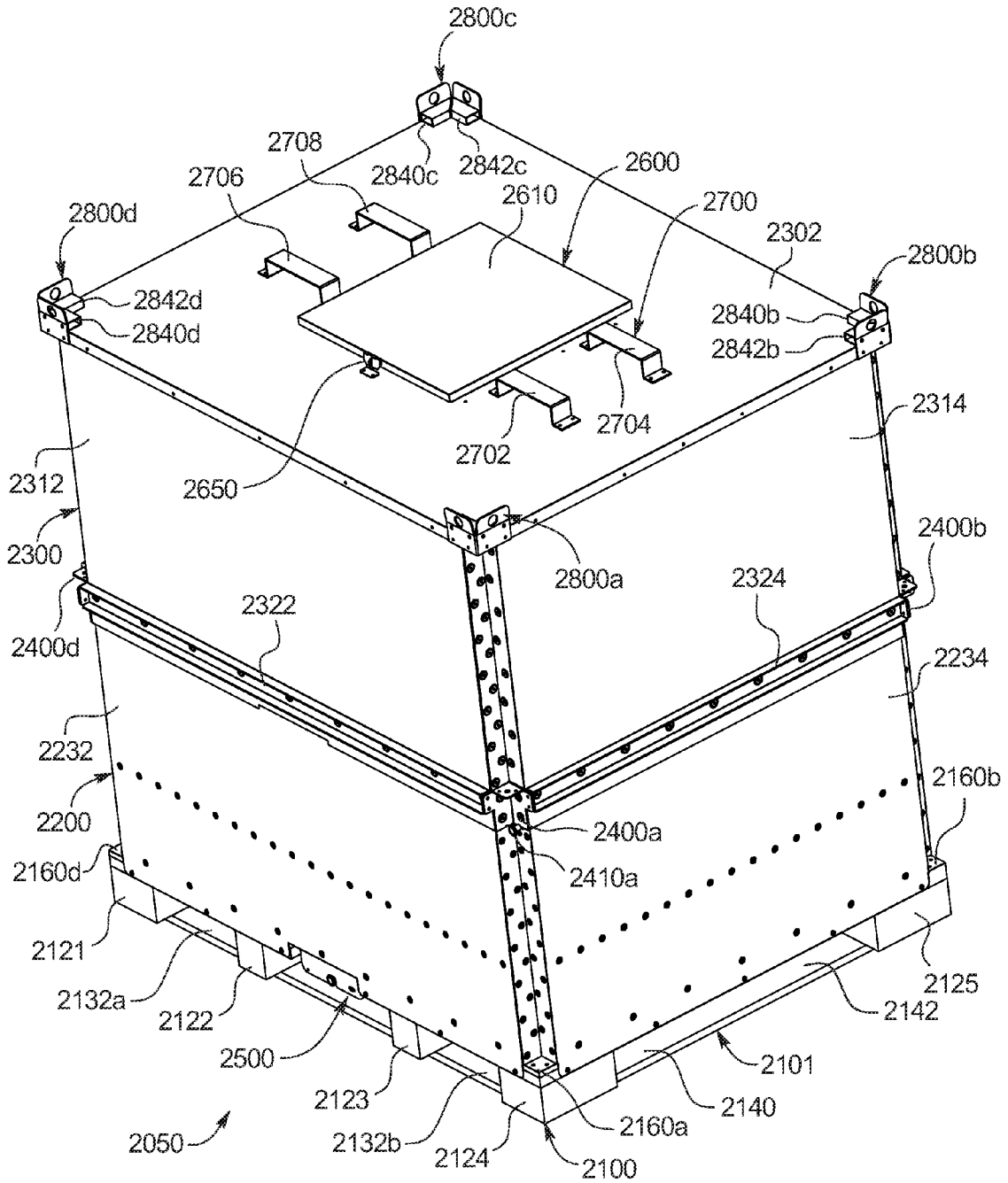

FIG. 47



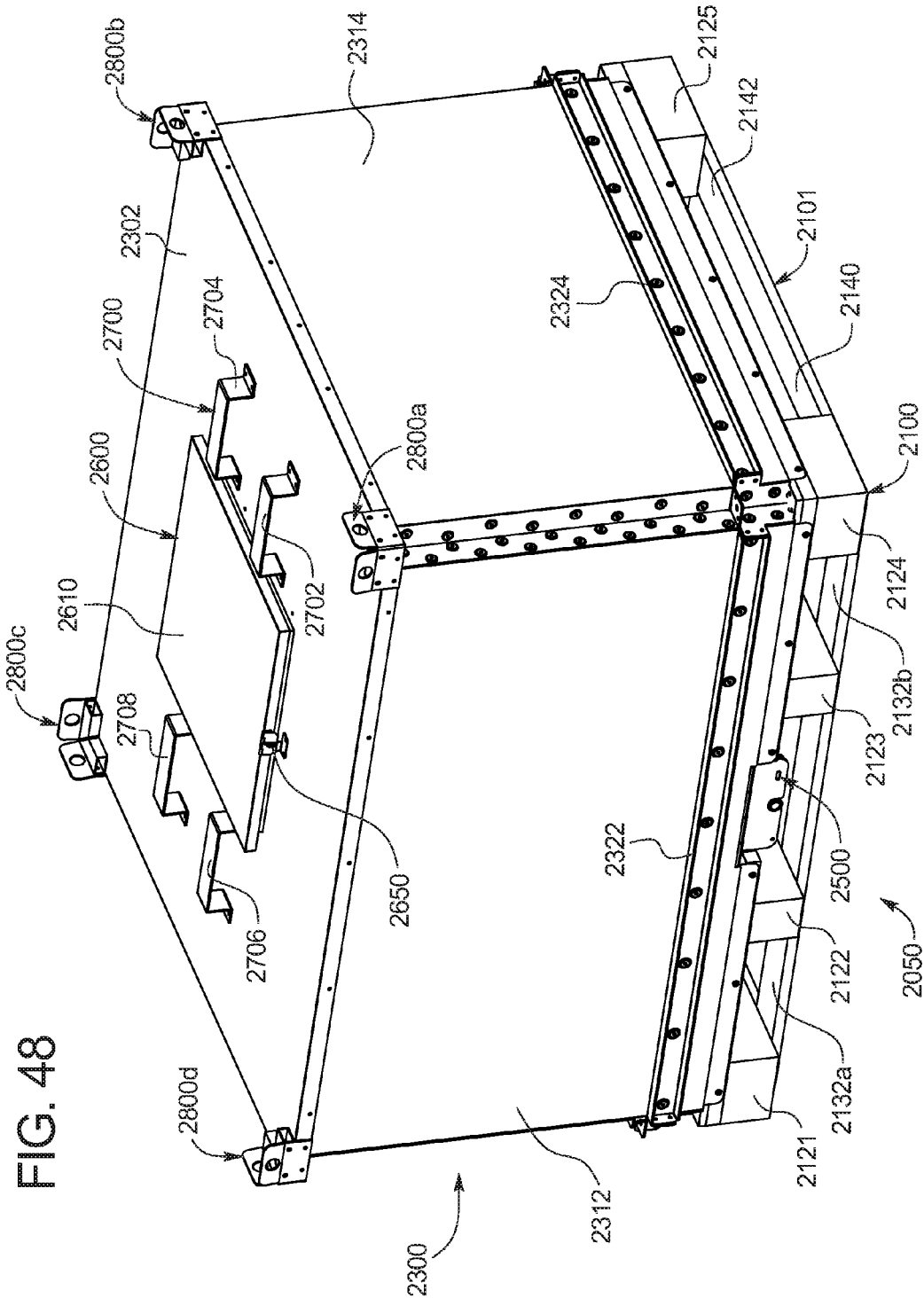

FIG. 48

FIG. 49

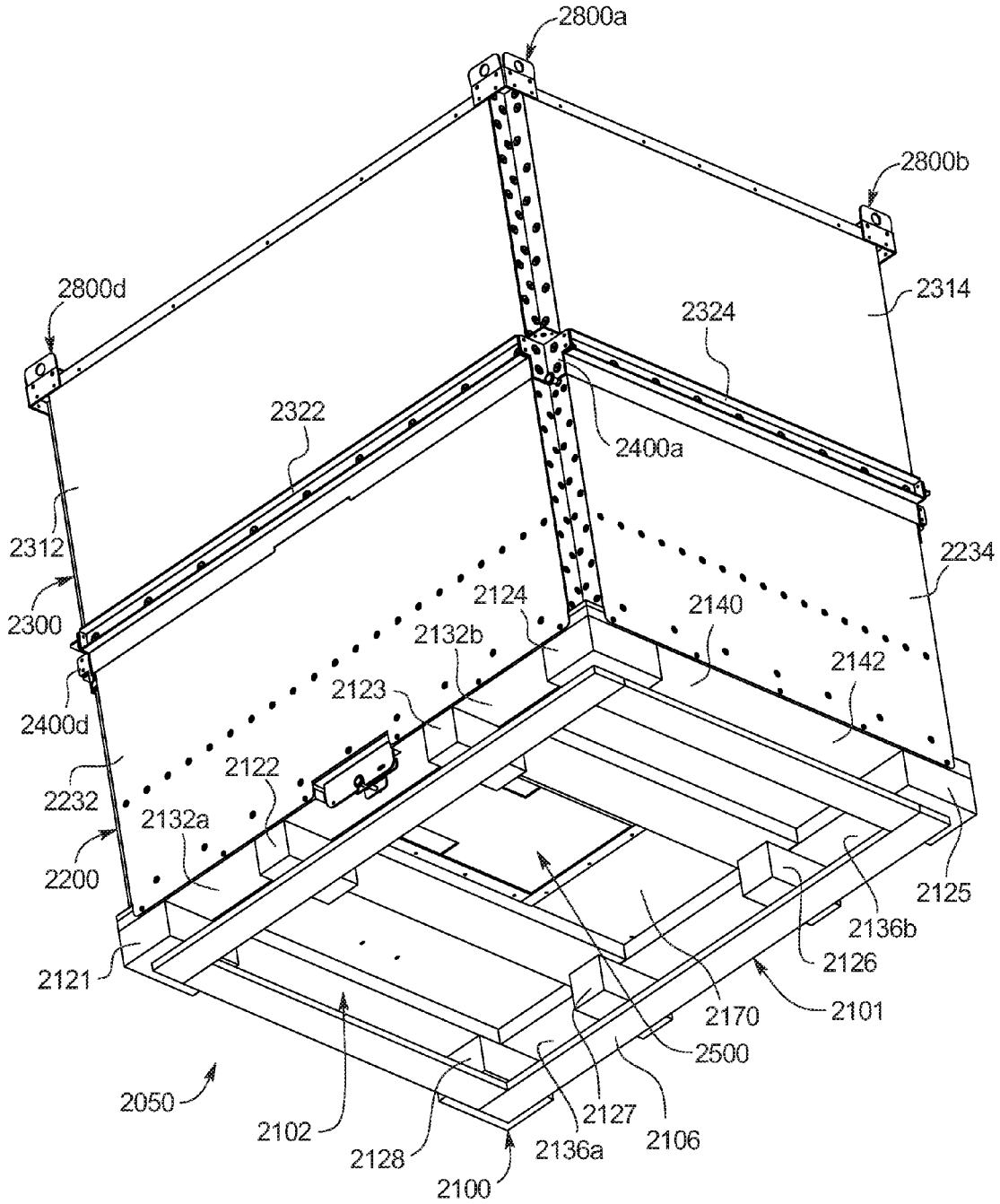

FIG. 50

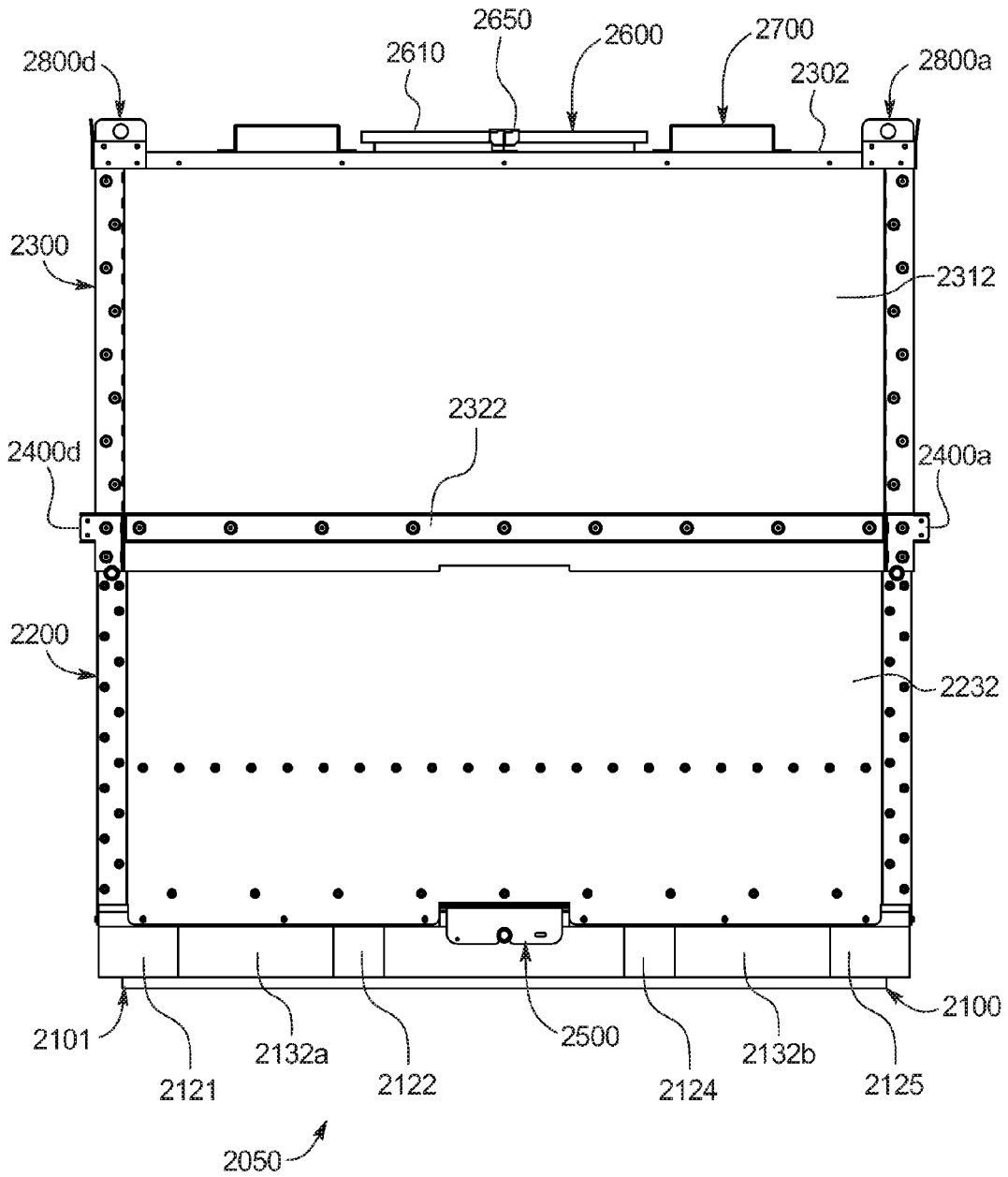

FIG. 51

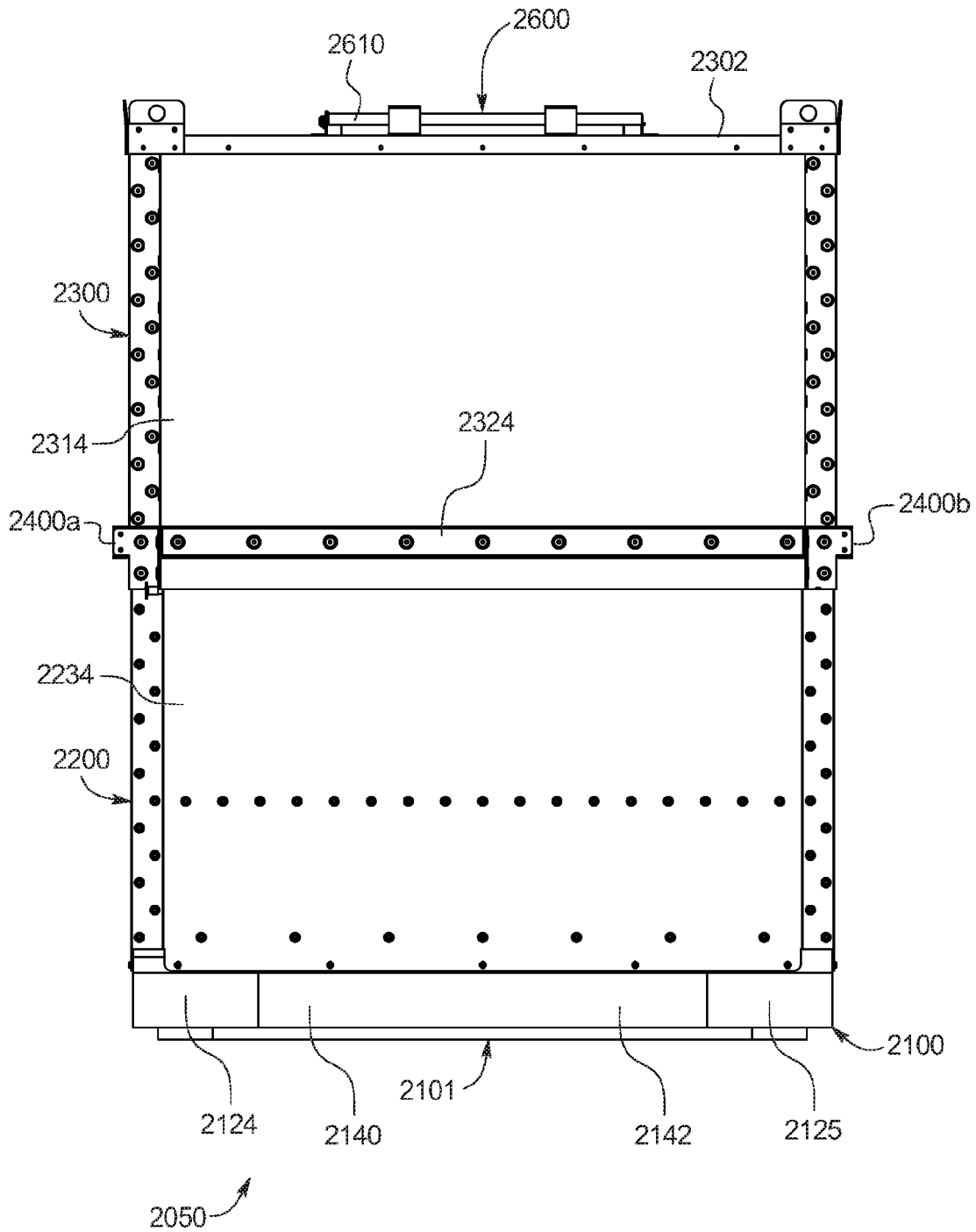

FIG. 52

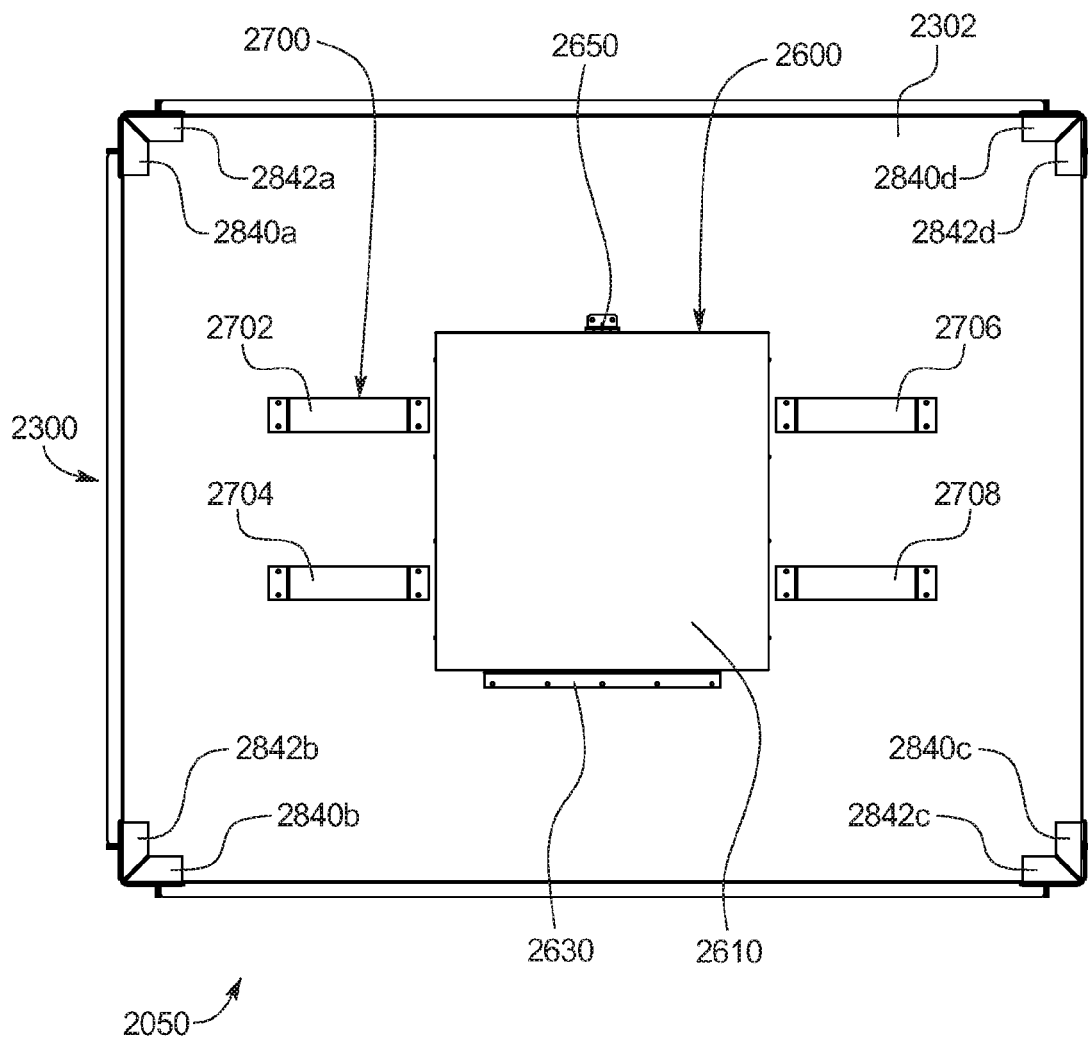

FIG. 53

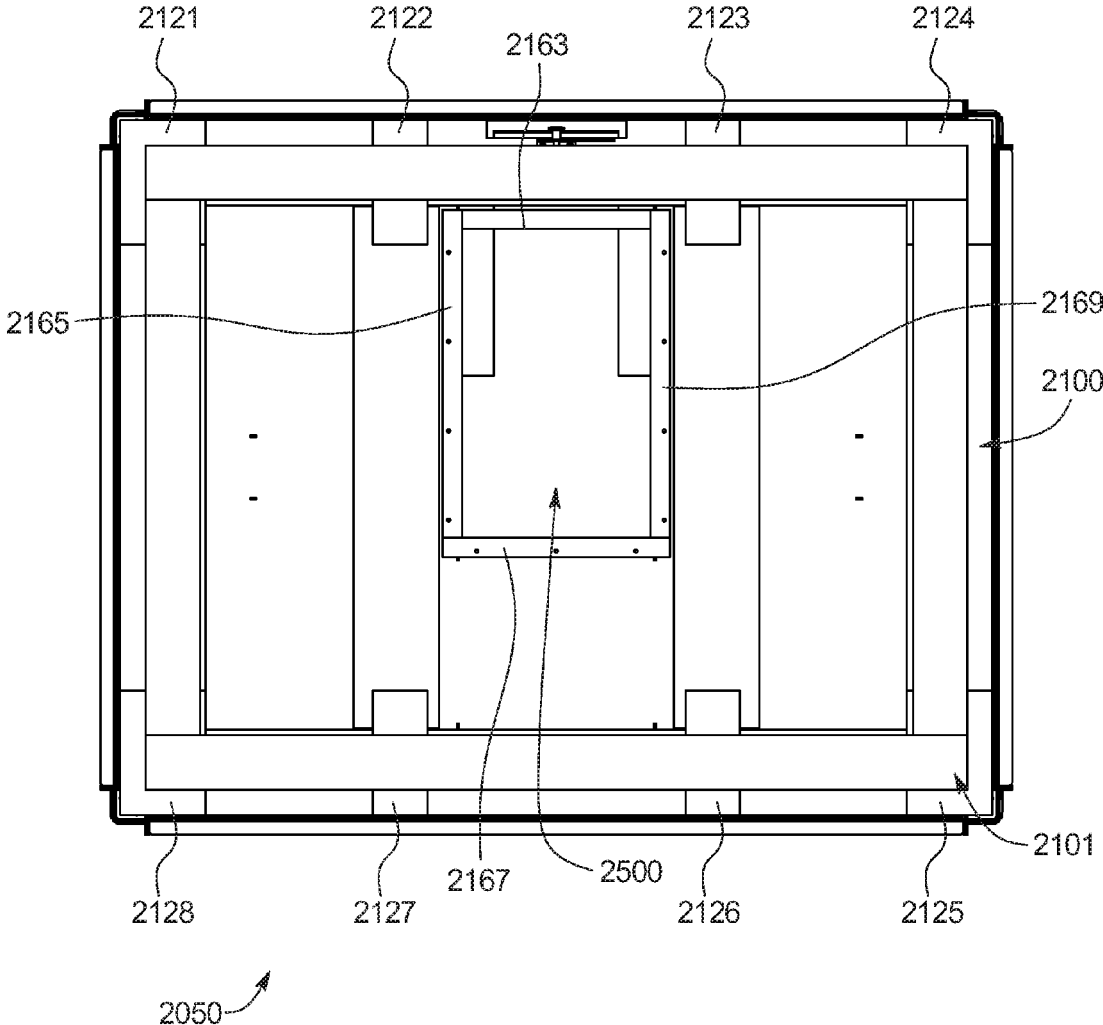

FIG. 54

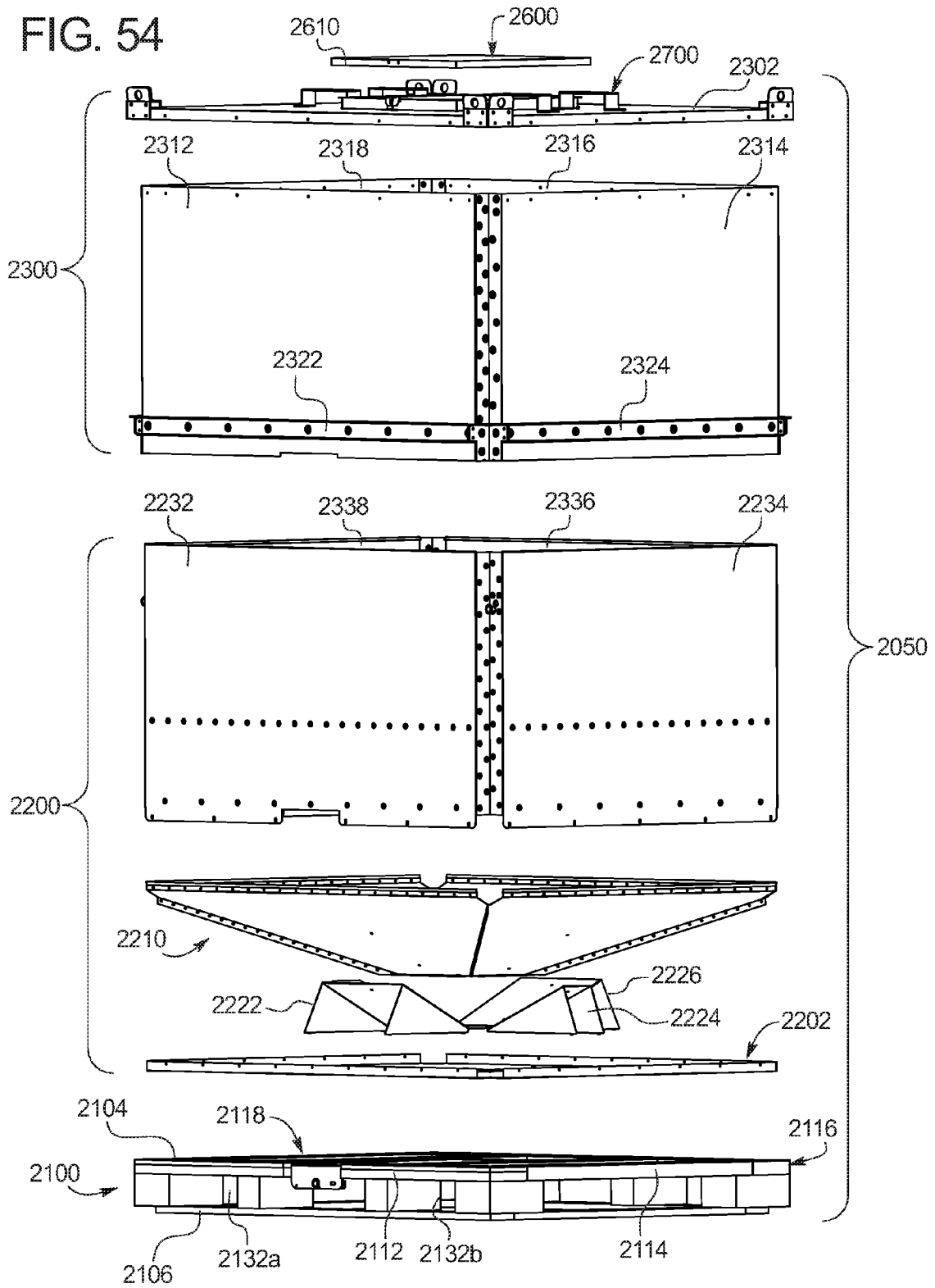

FIG. 55

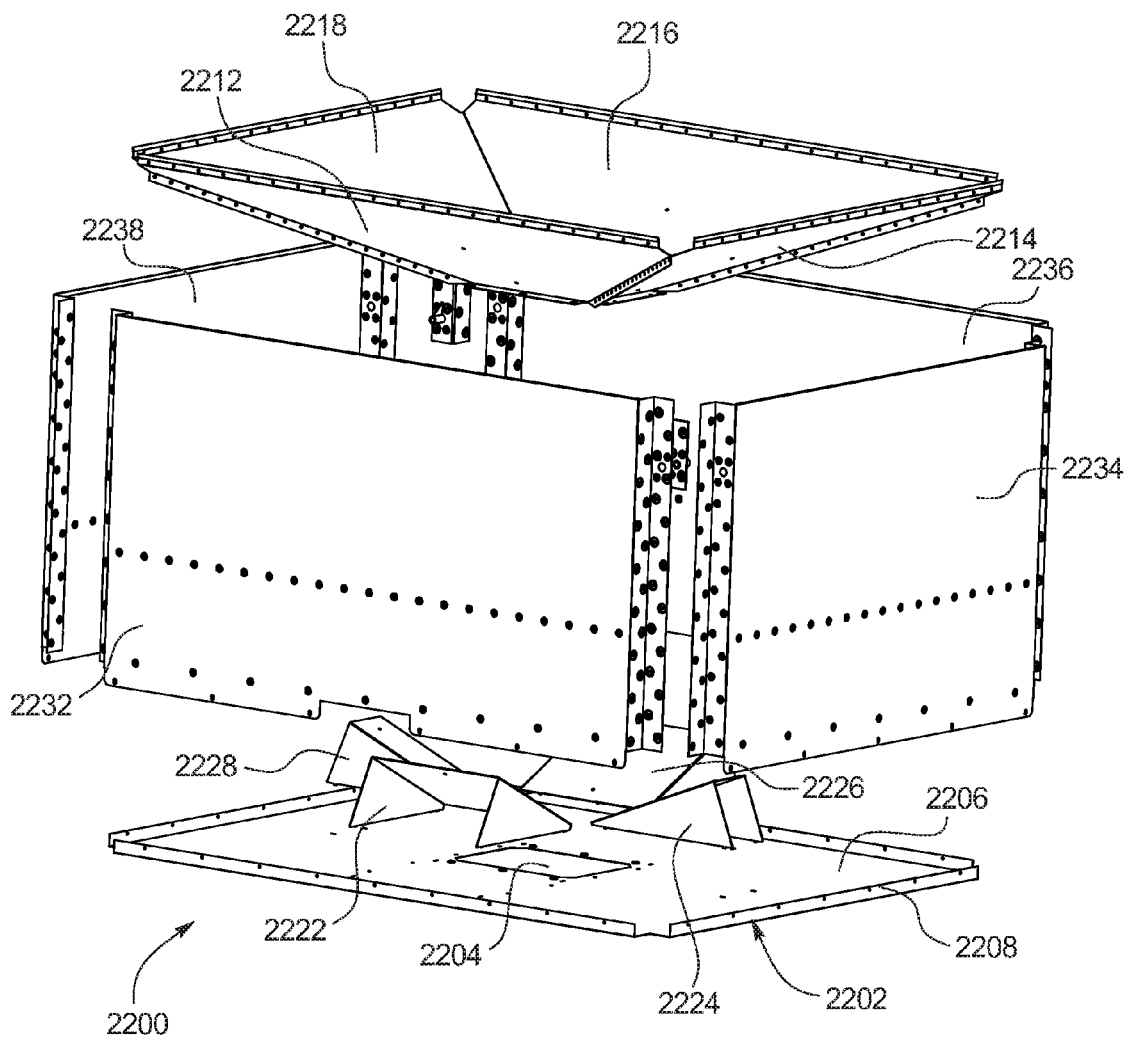

FIG. 56

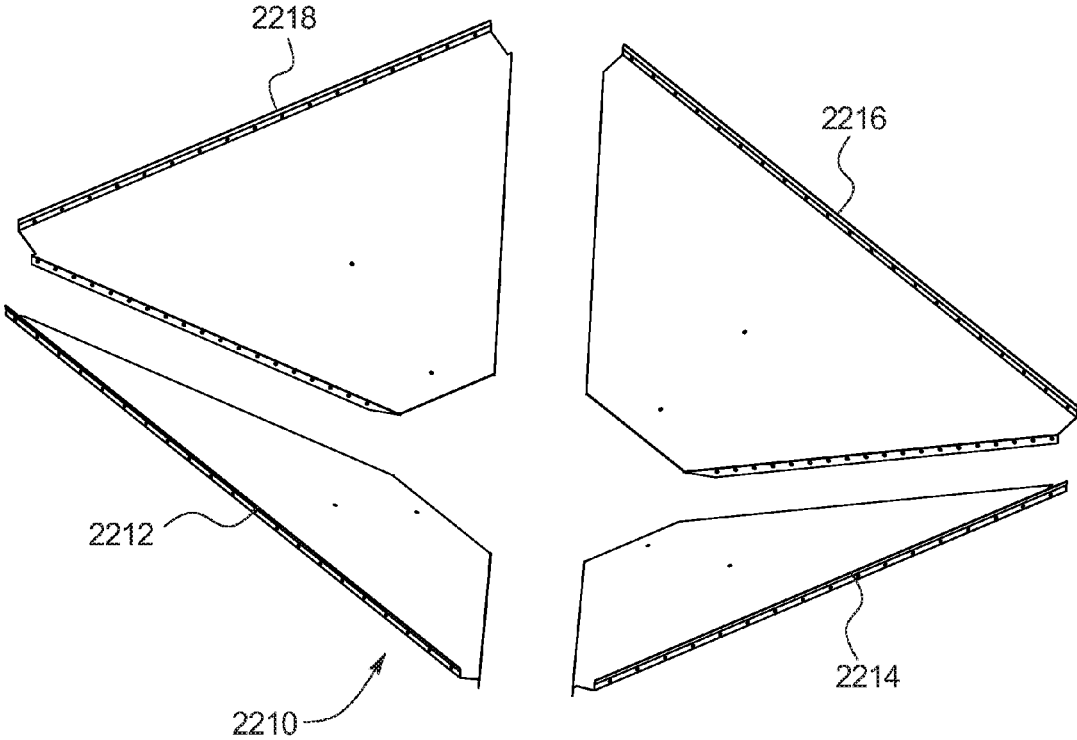

FIG. 57

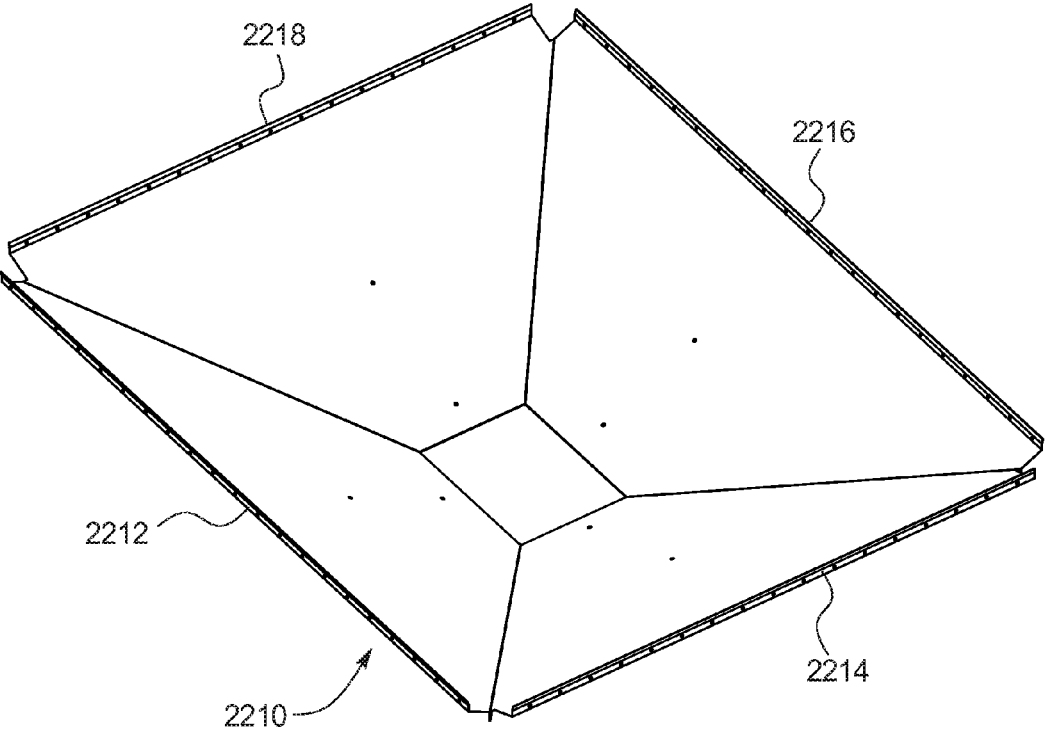

FIG. 58

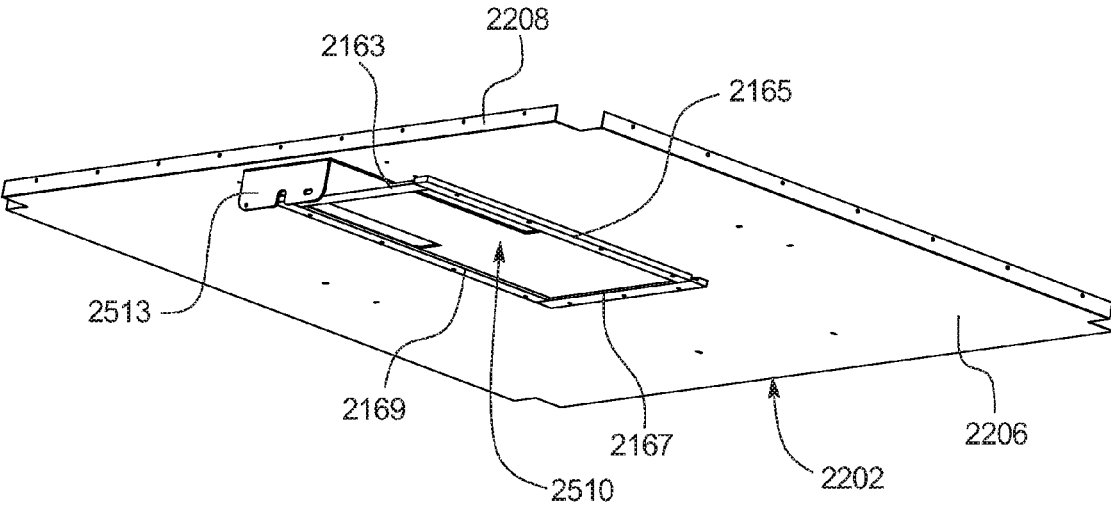

FIG. 59

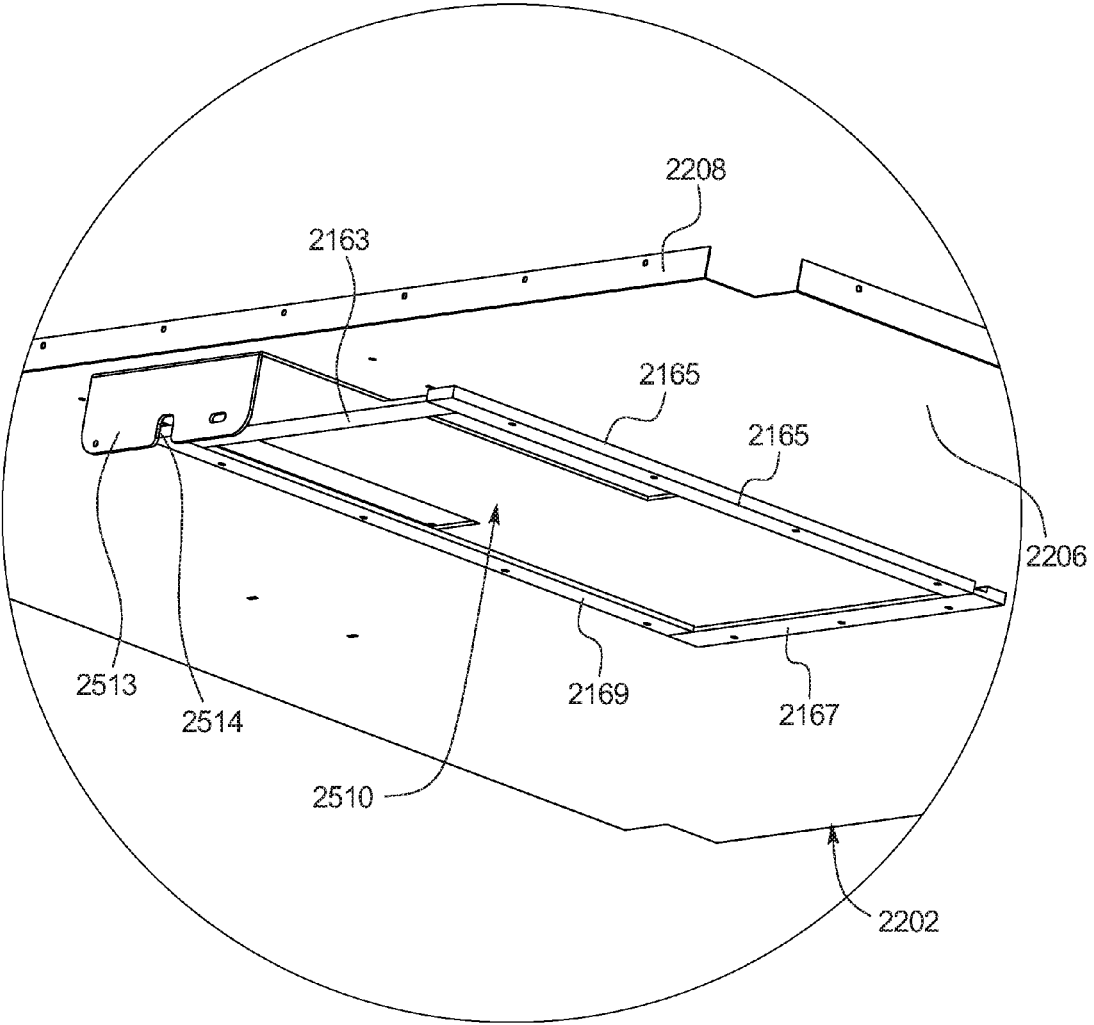

FIG. 60

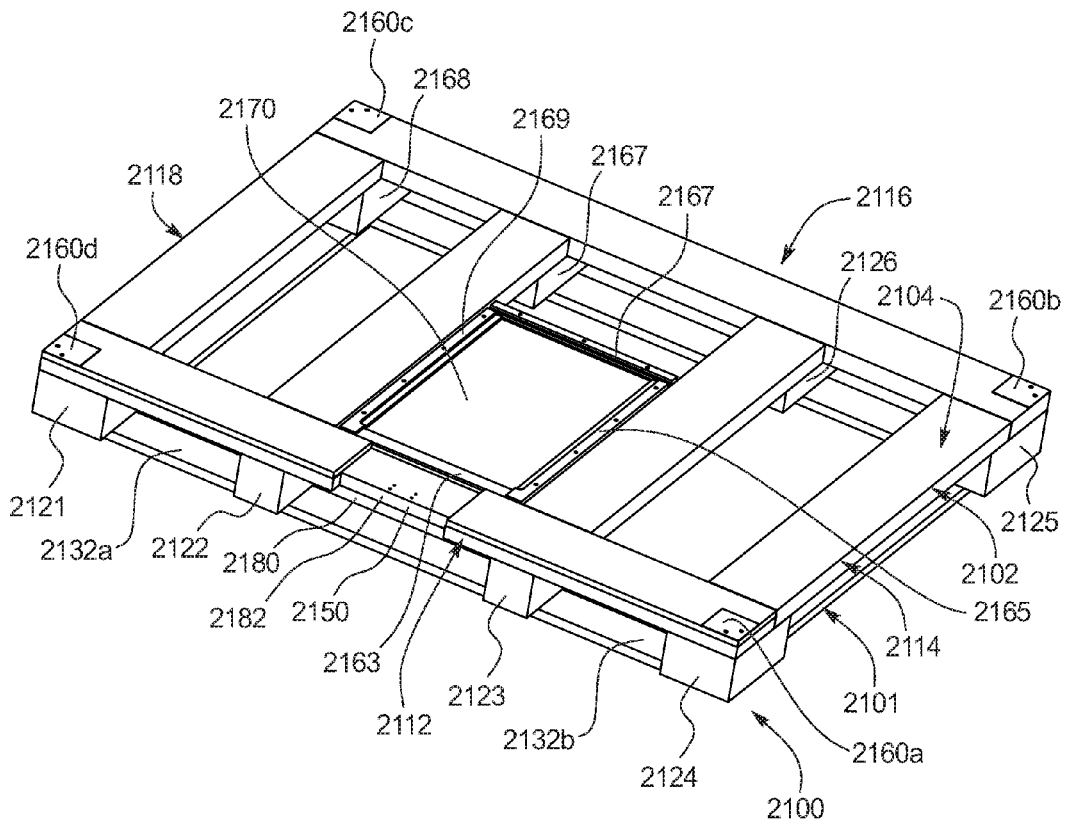

FIG. 61

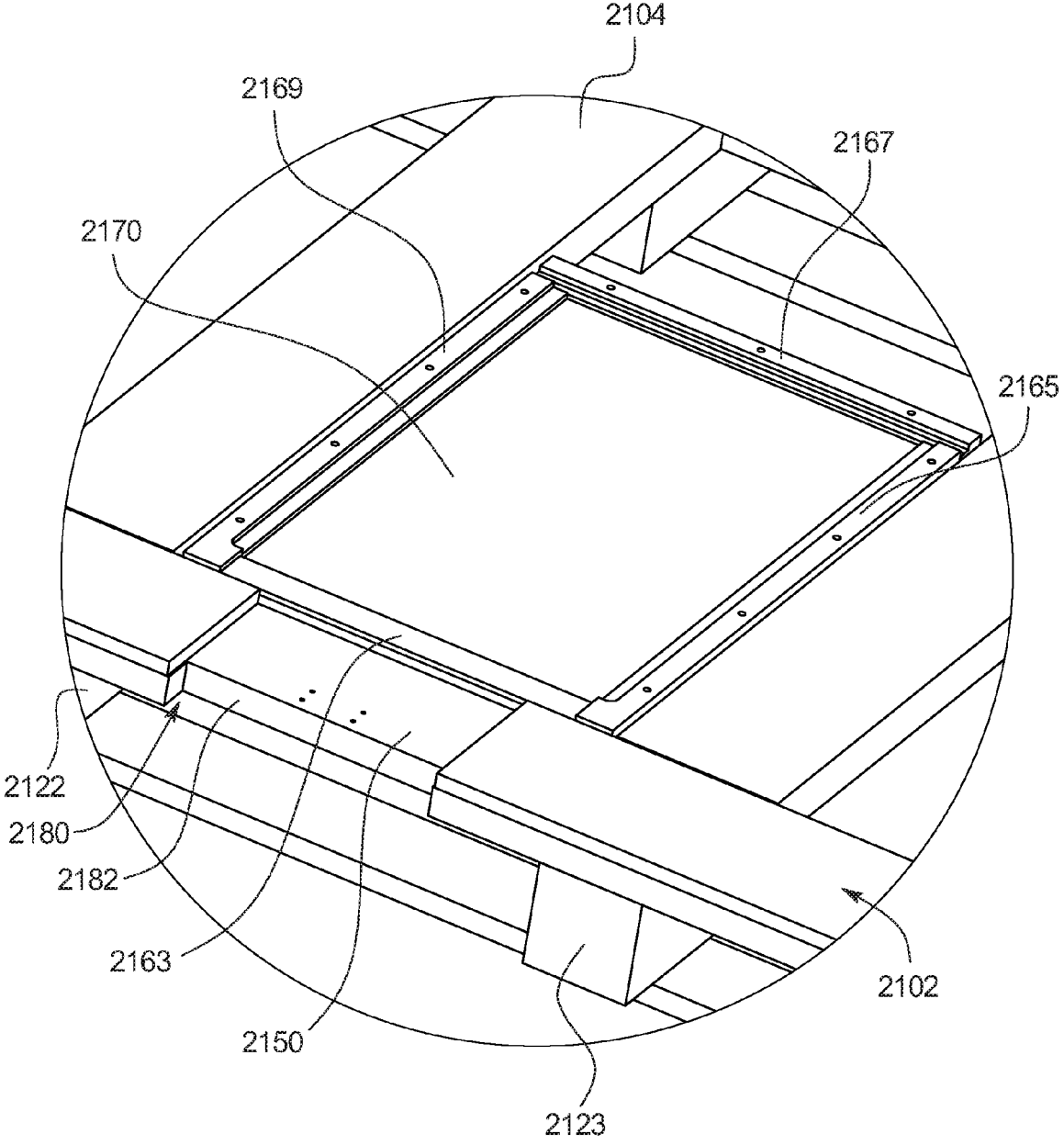

FIG. 62

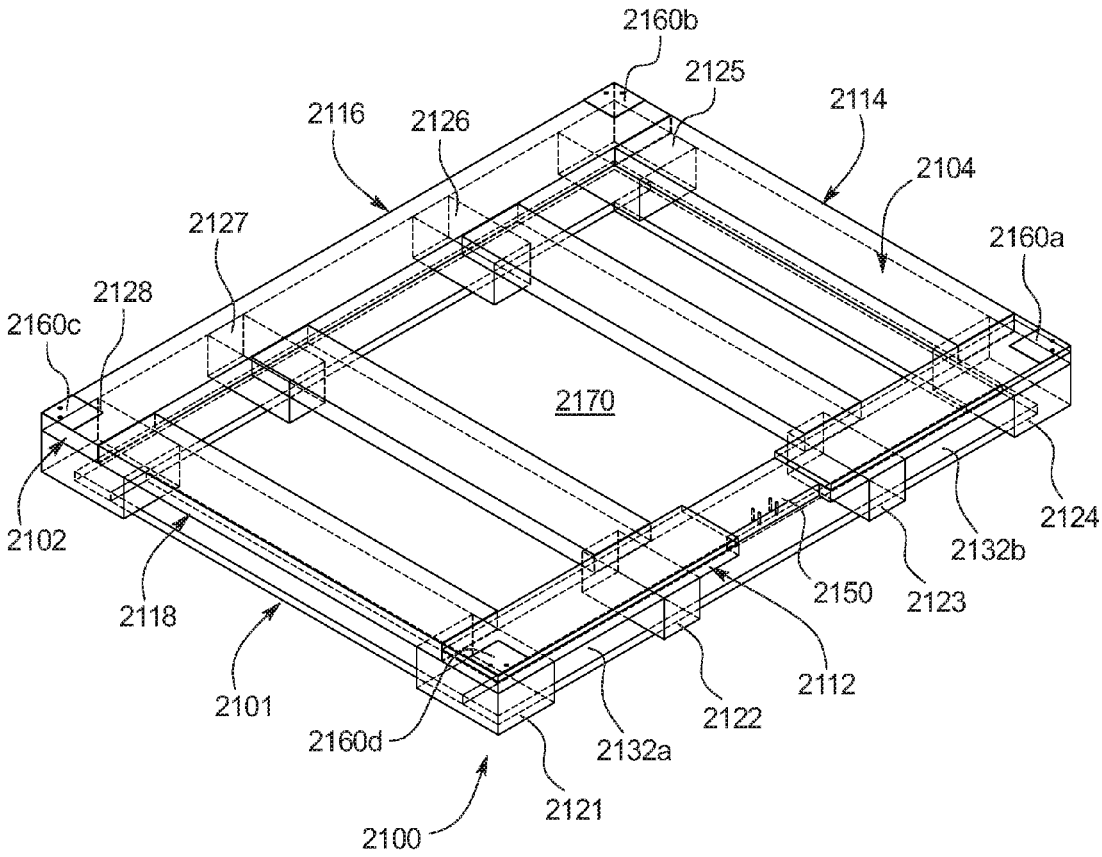

FIG. 63

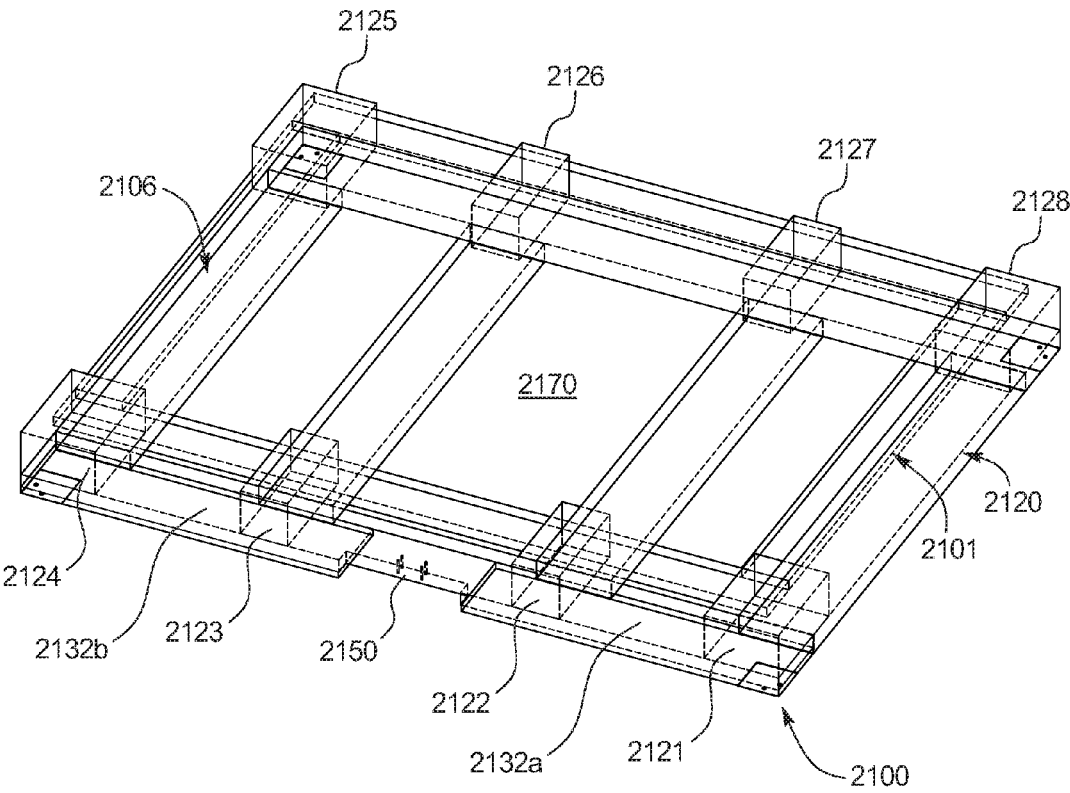

FIG. 64

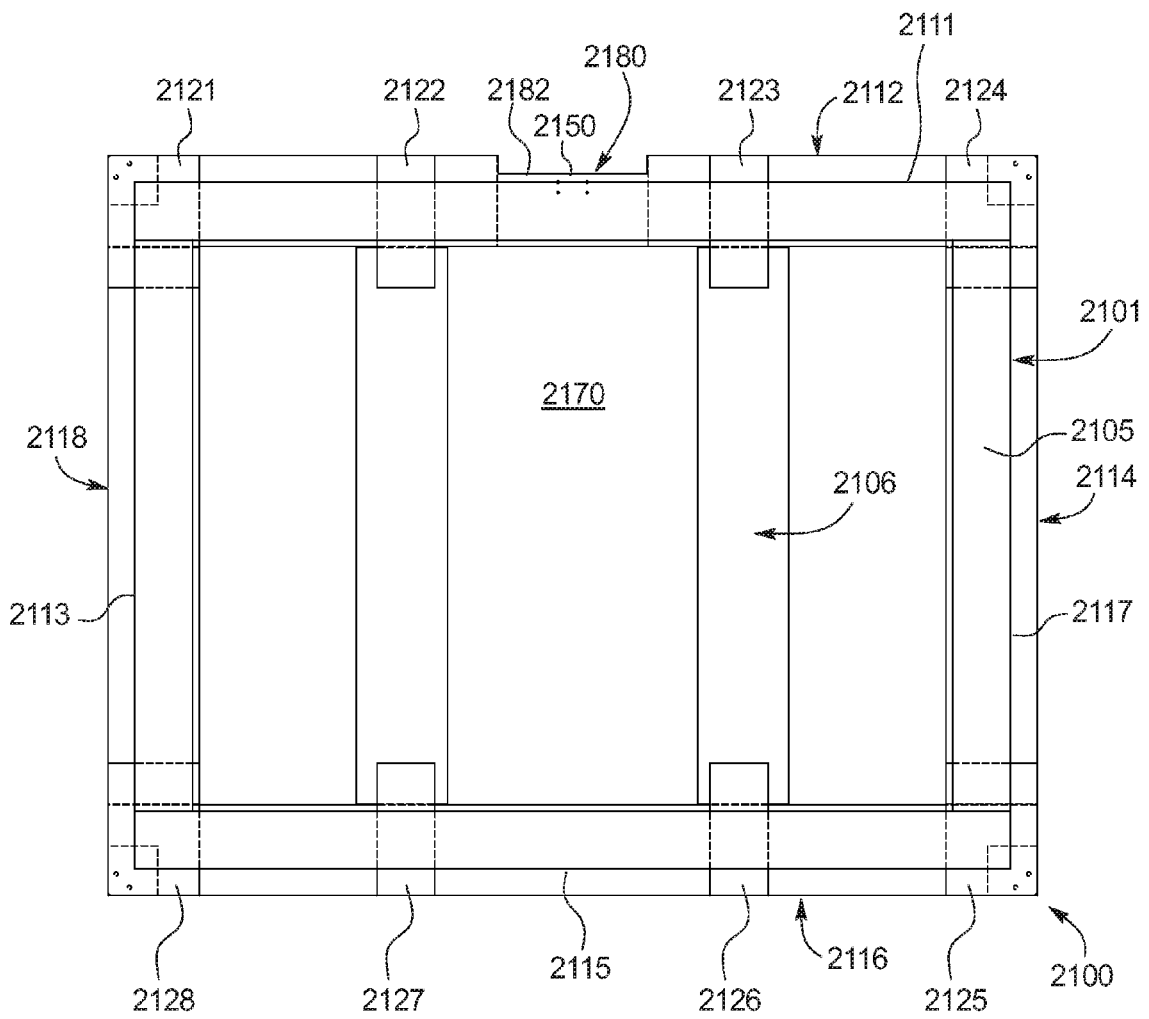

FIG. 65

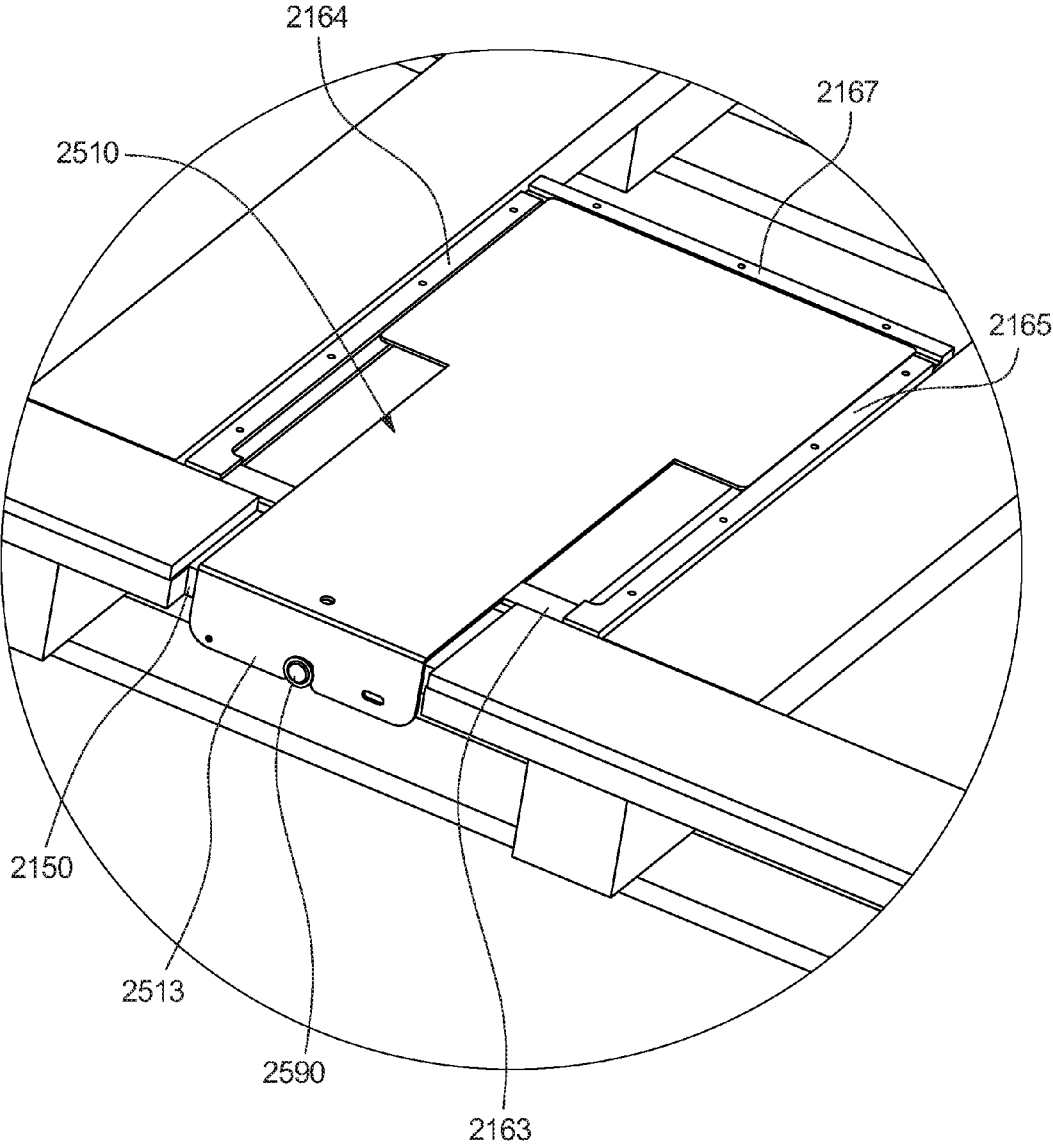

FIG. 66

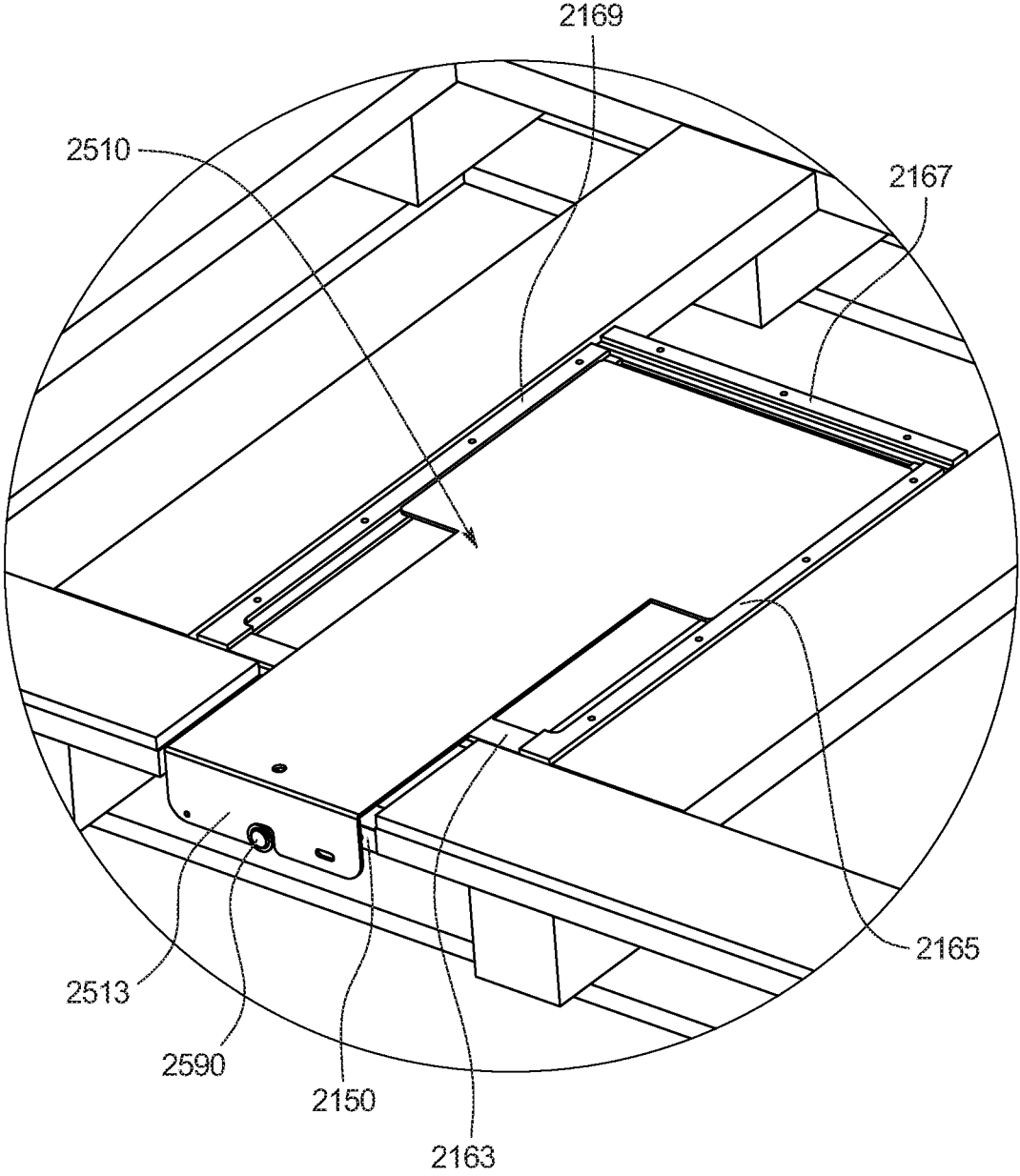

FIG. 67

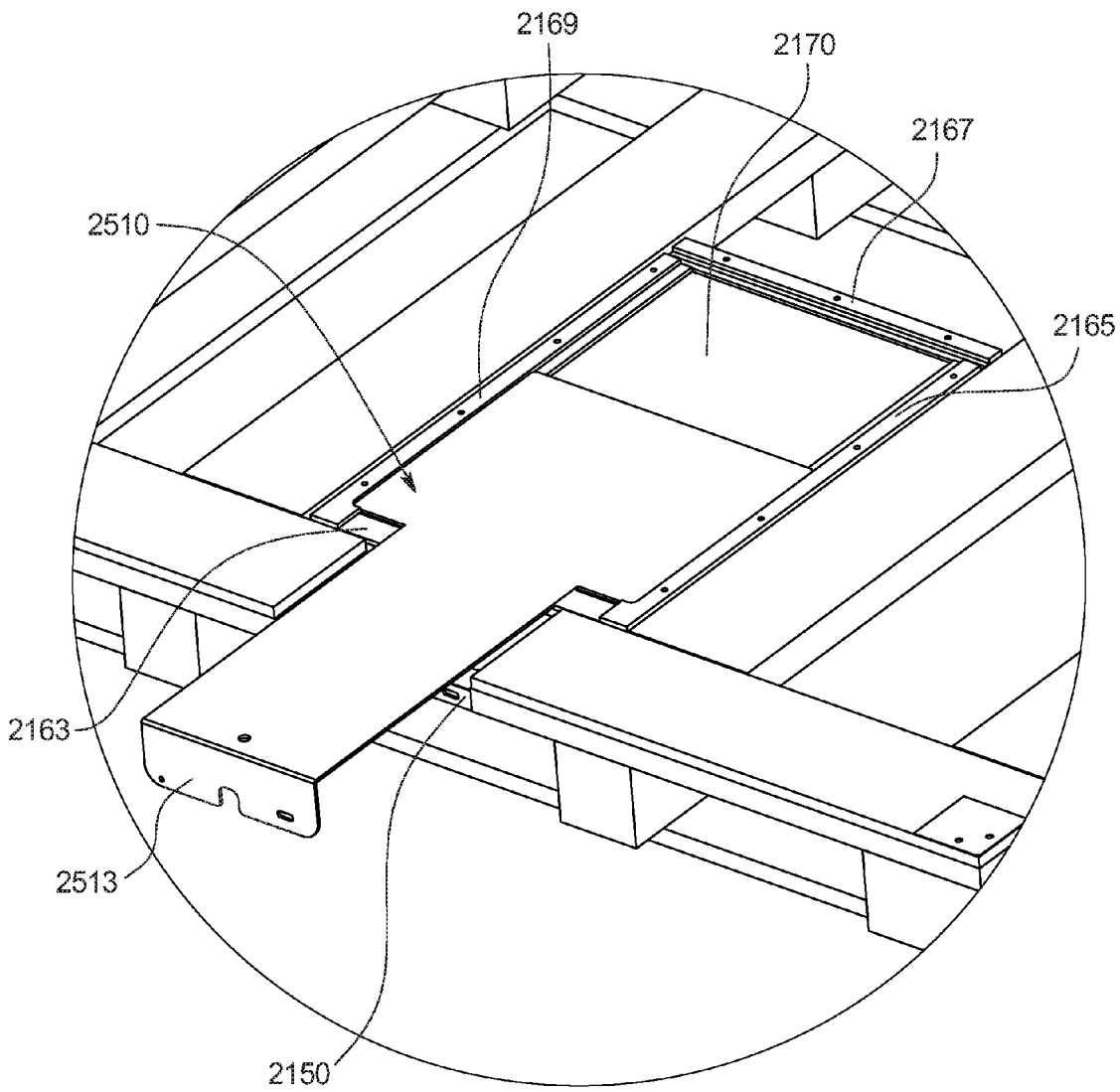

FIG. 68

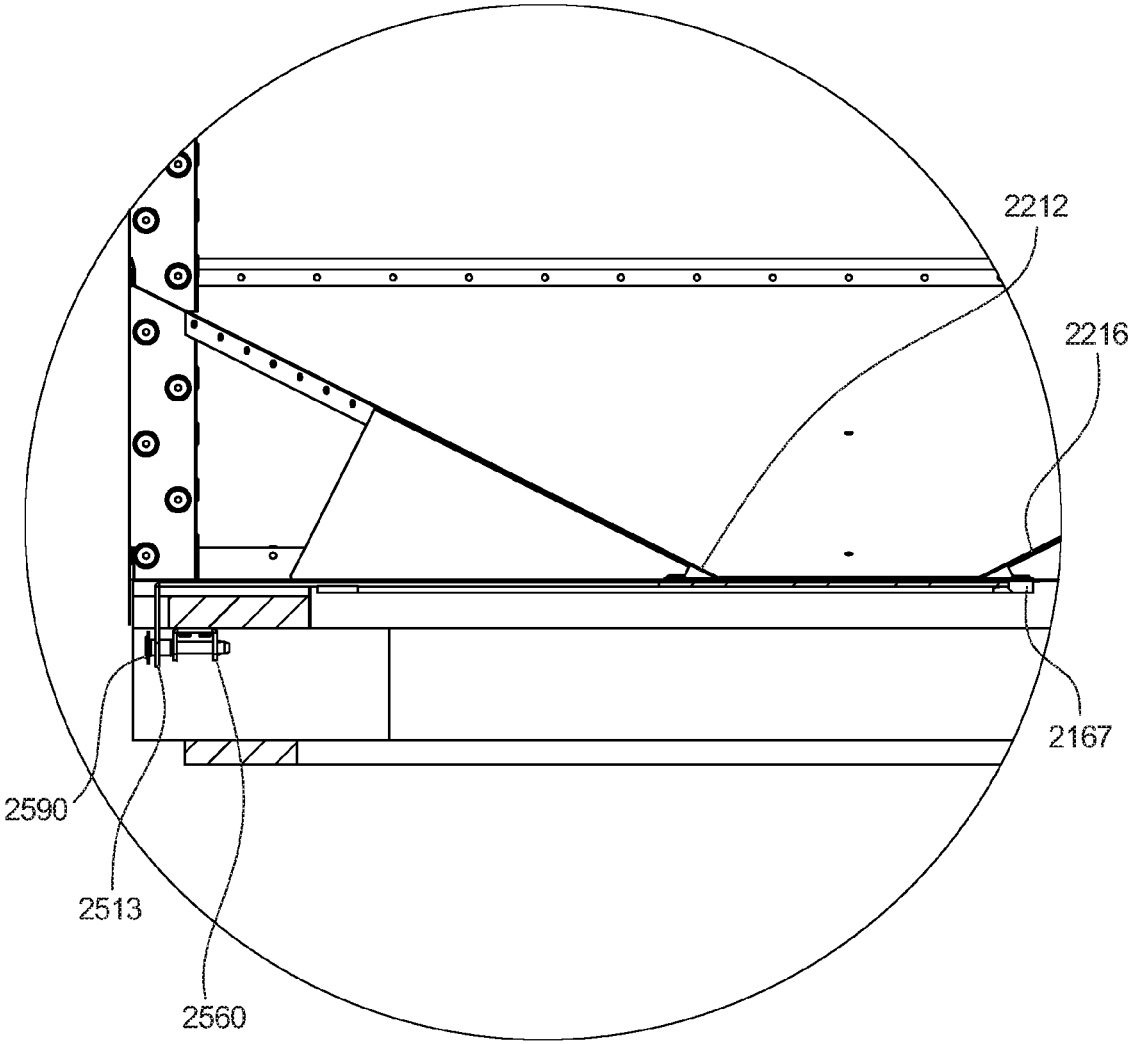

FIG. 69

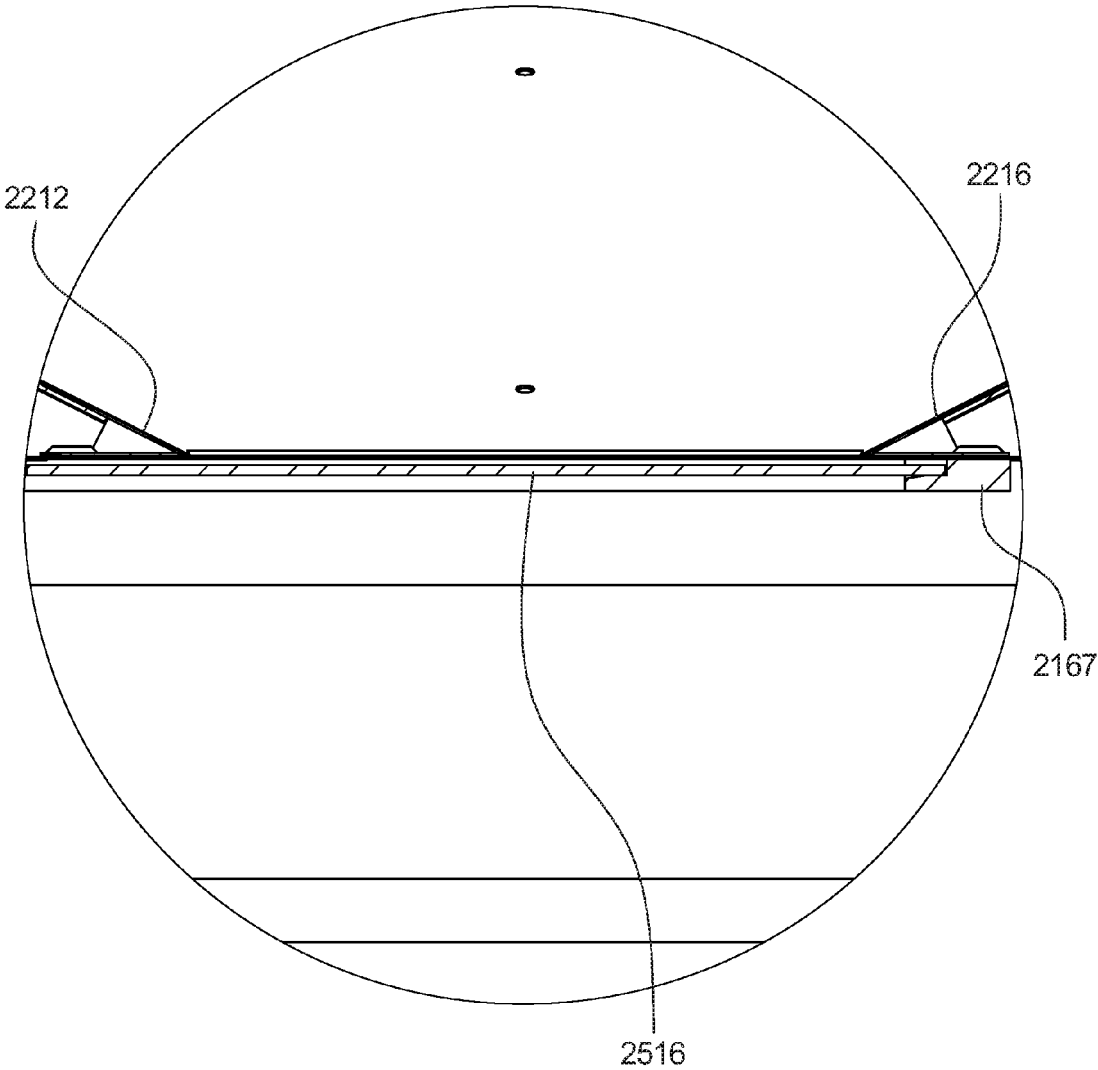

FIG. 70

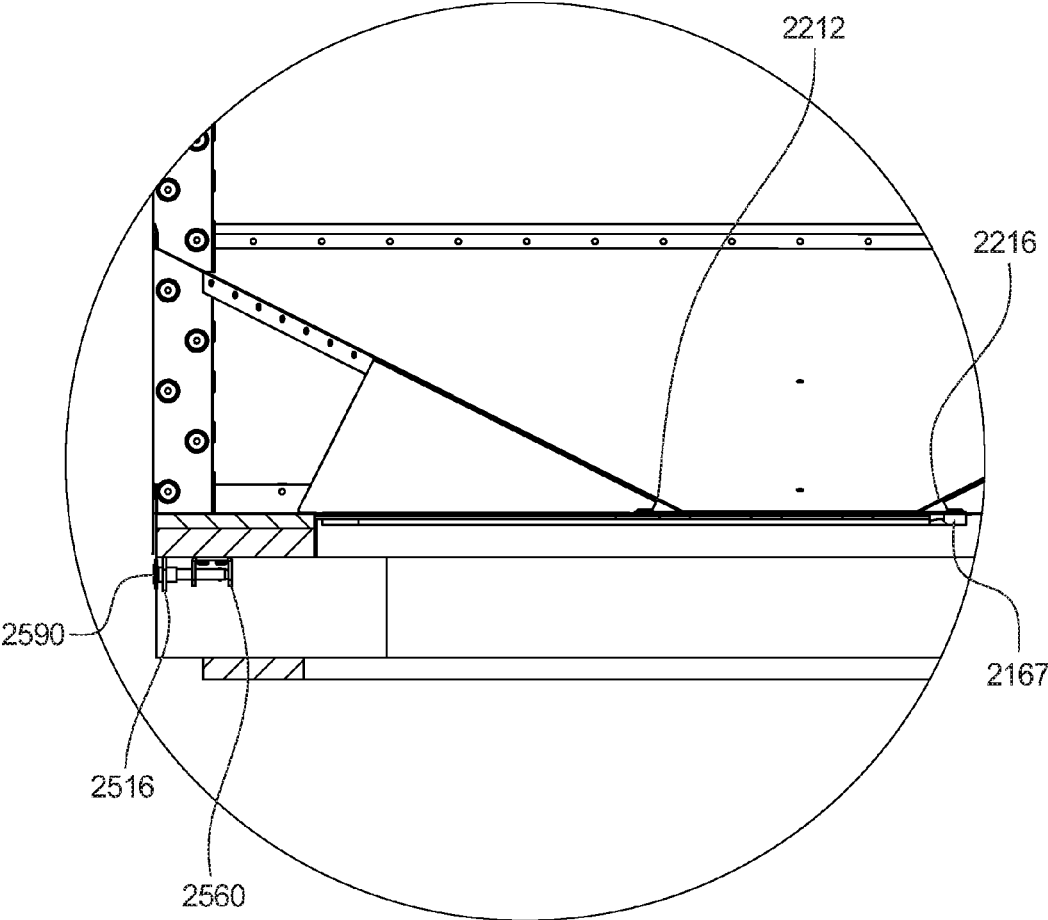

FIG. 71

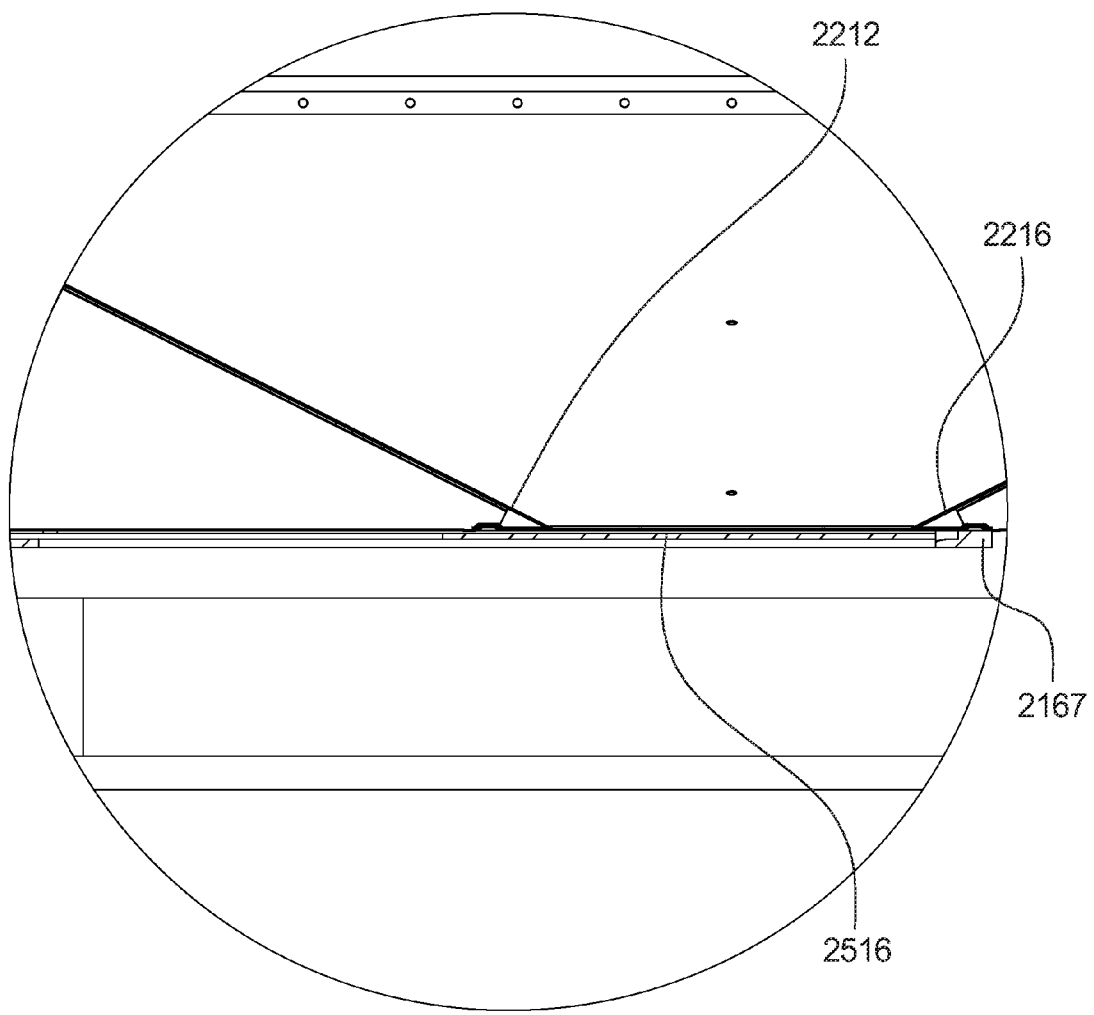

FIG. 72

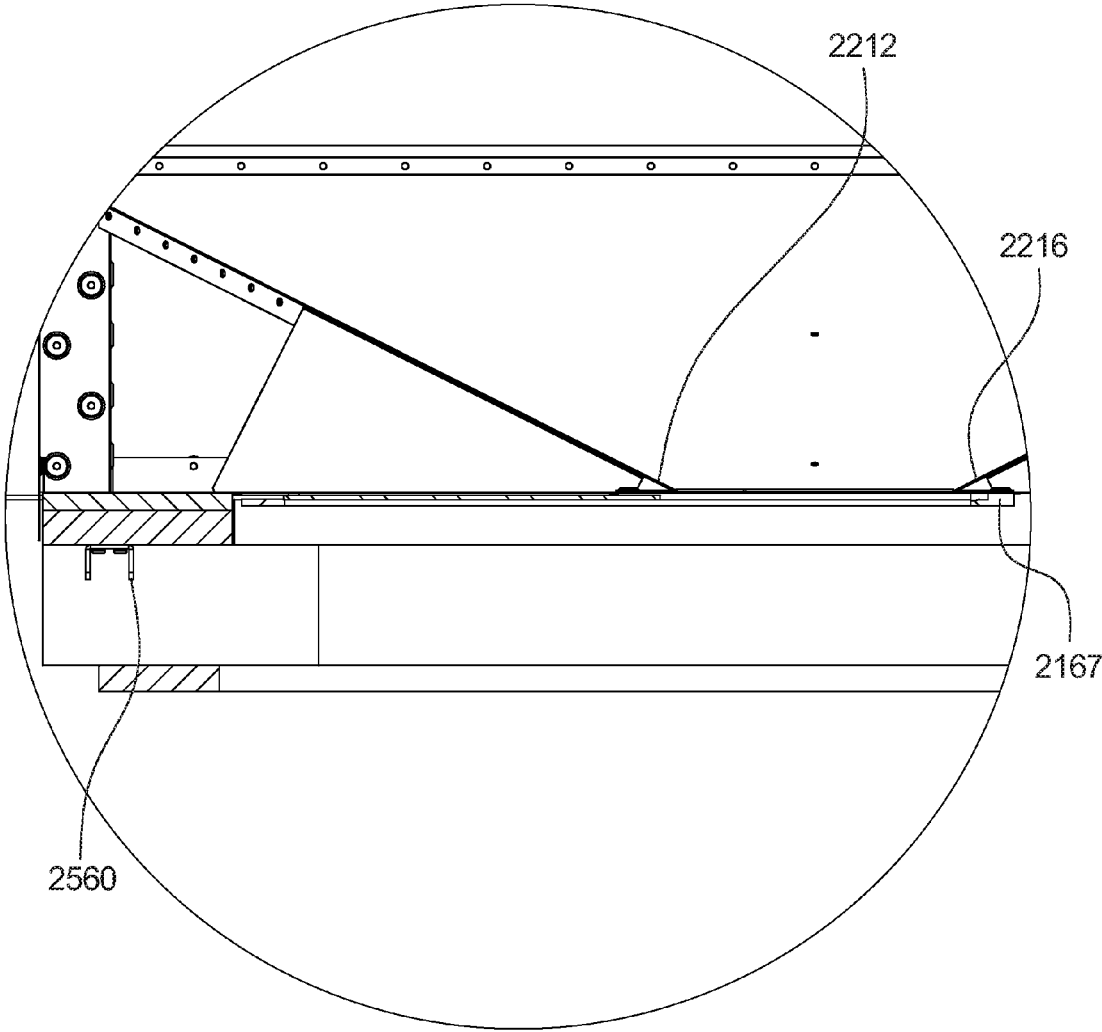

FIG. 73

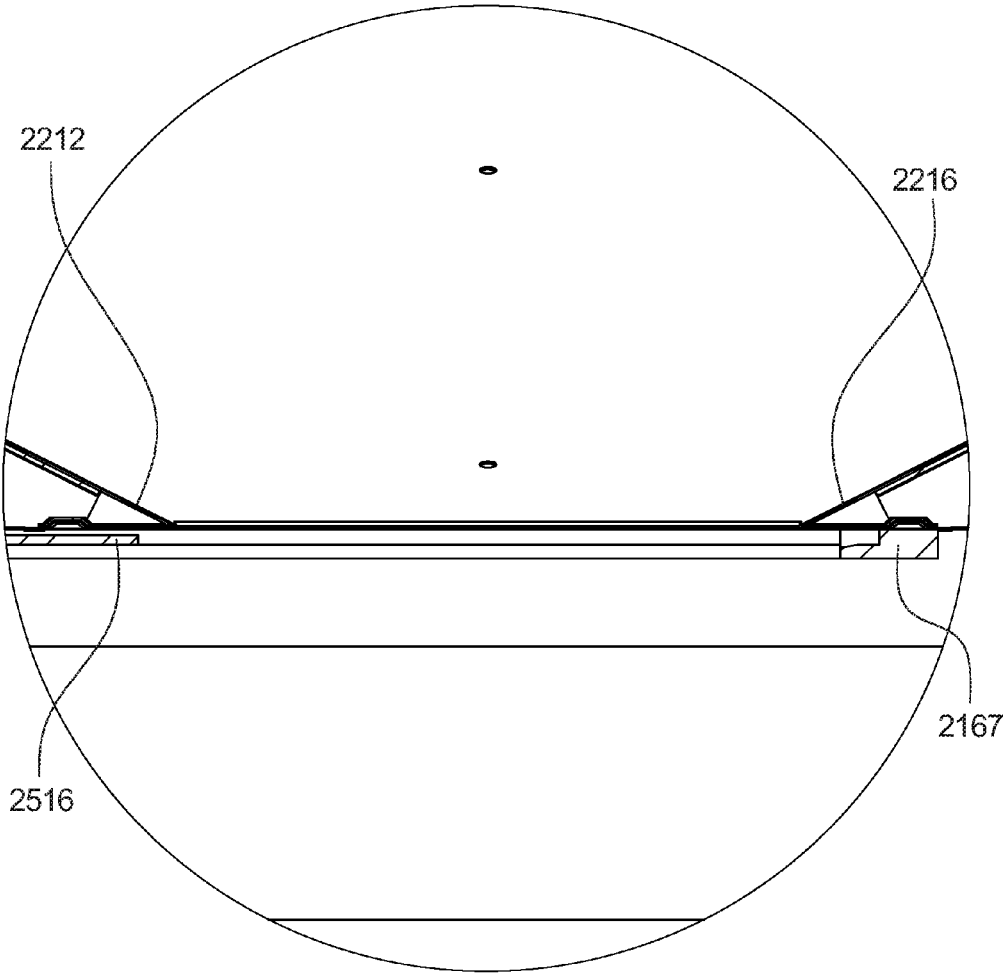

FIG. 74

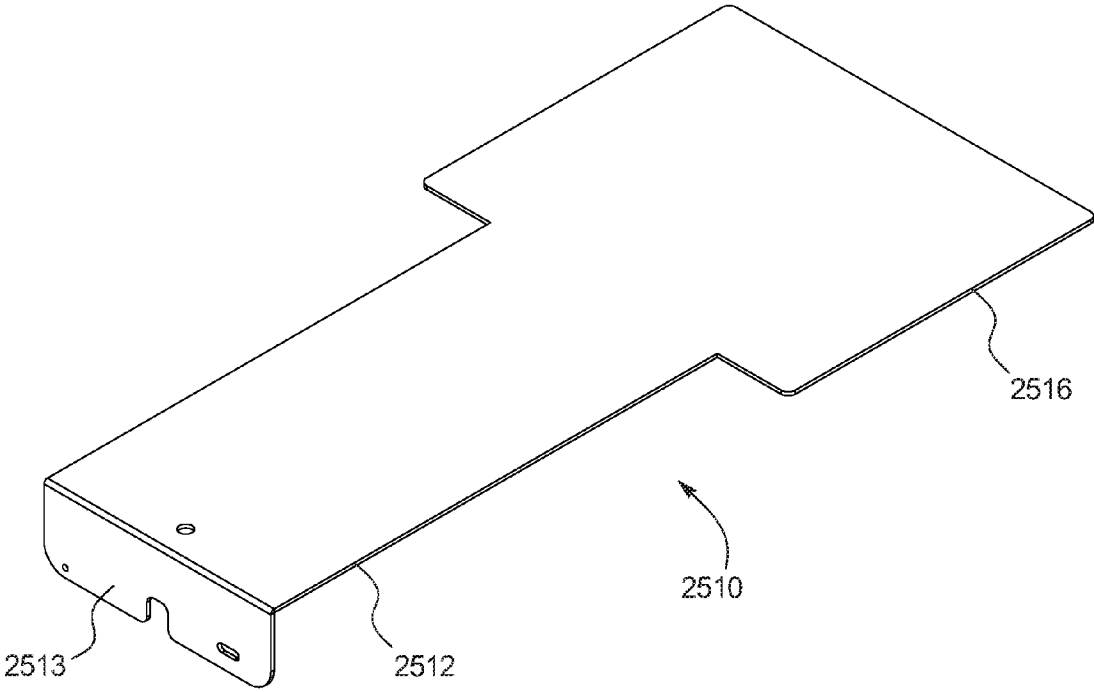

FIG. 75

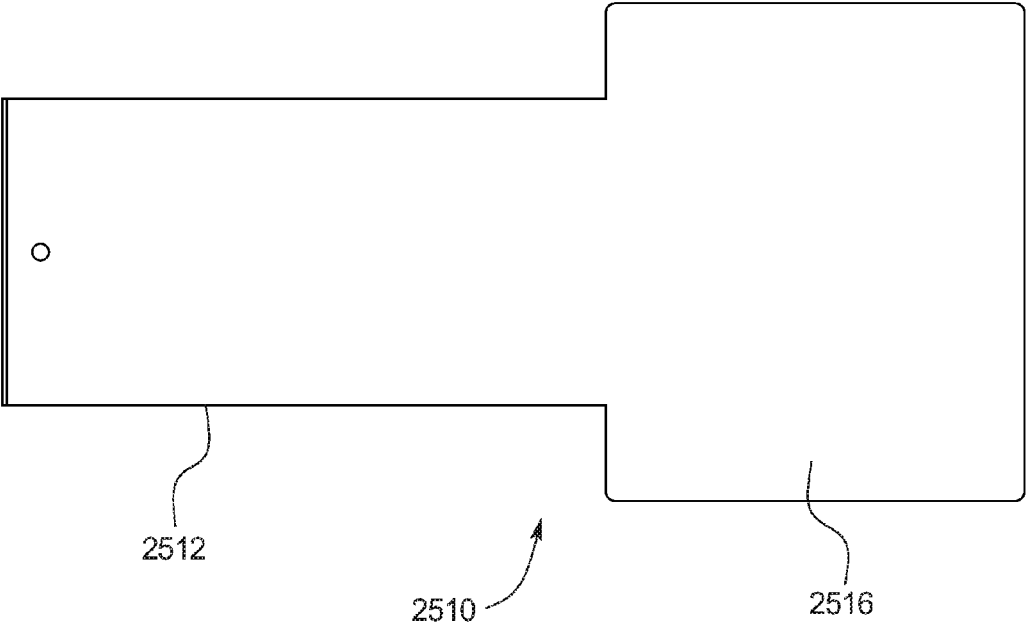

FIG. 76

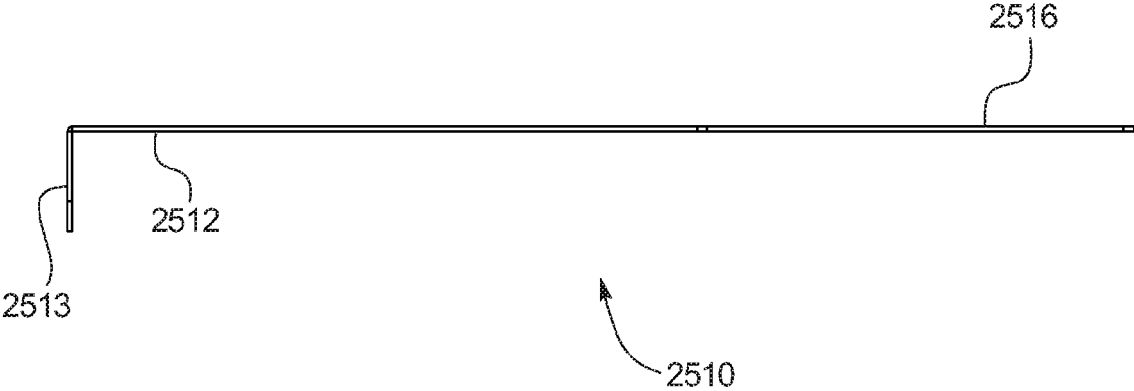

FIG. 77

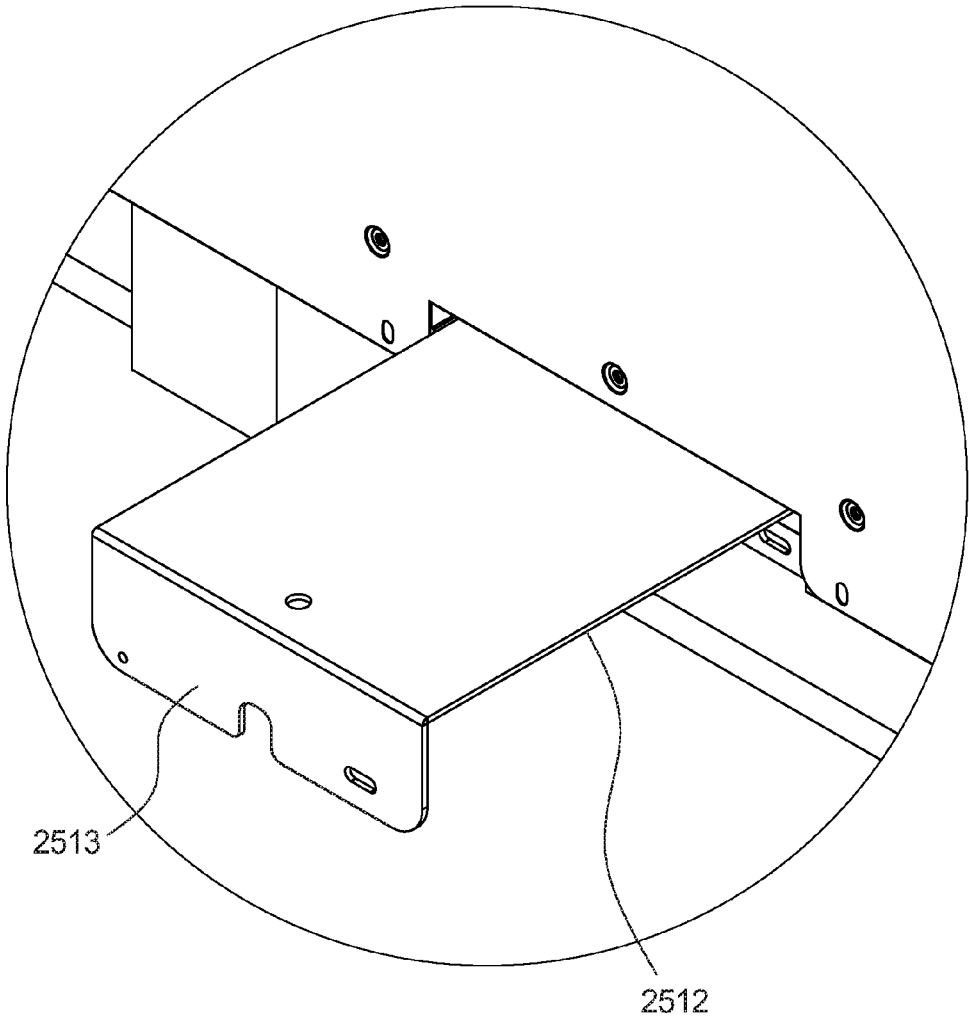

FIG. 78

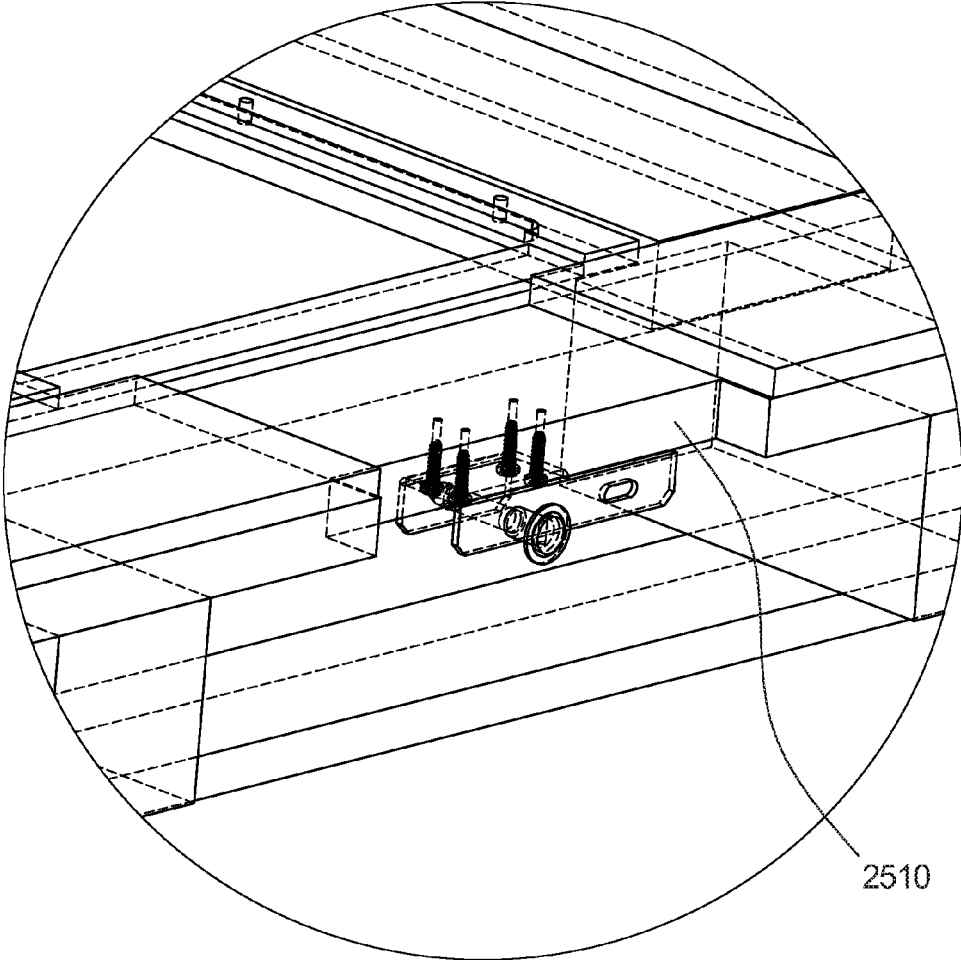

FIG. 79

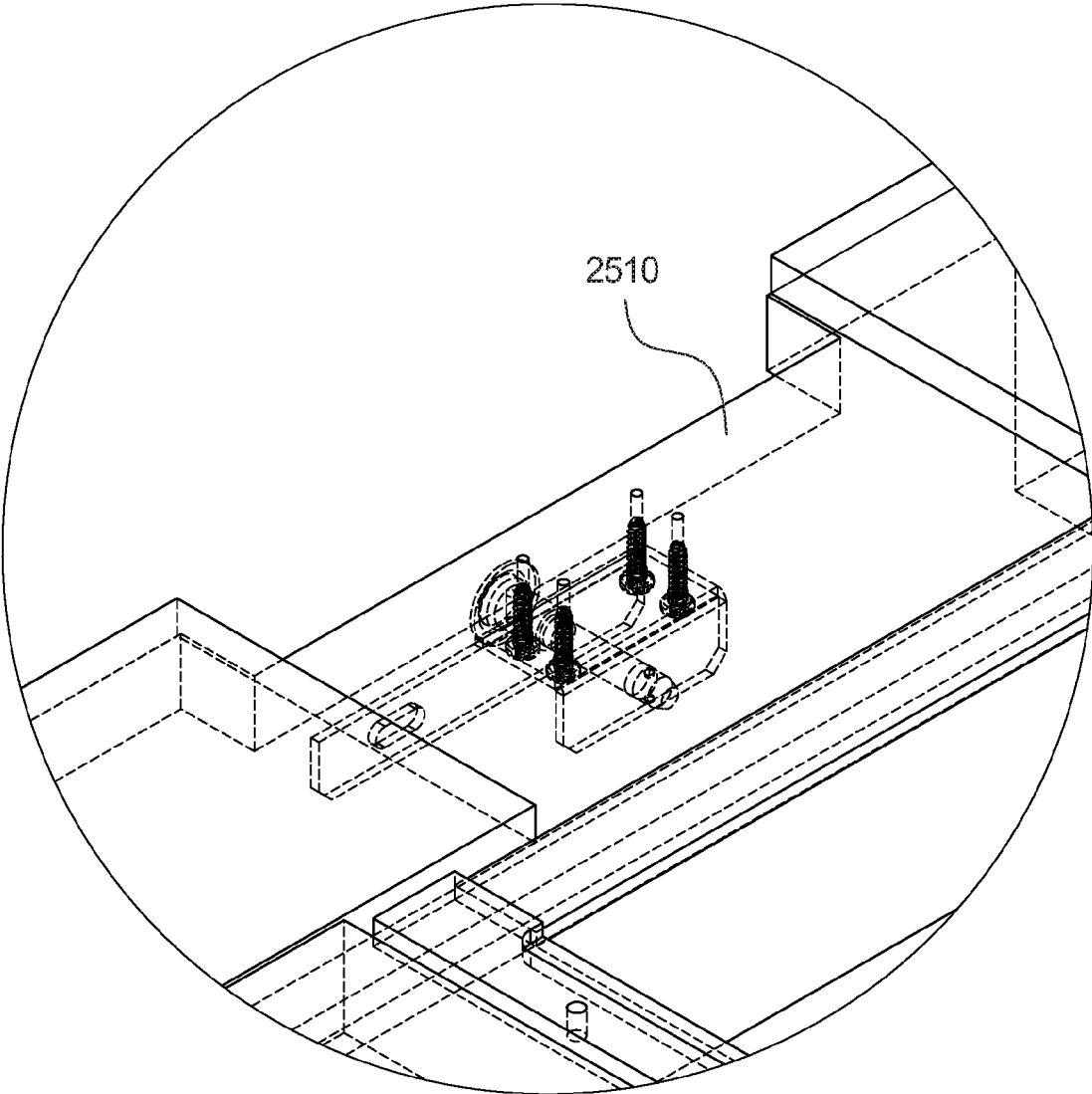

FIG. 80

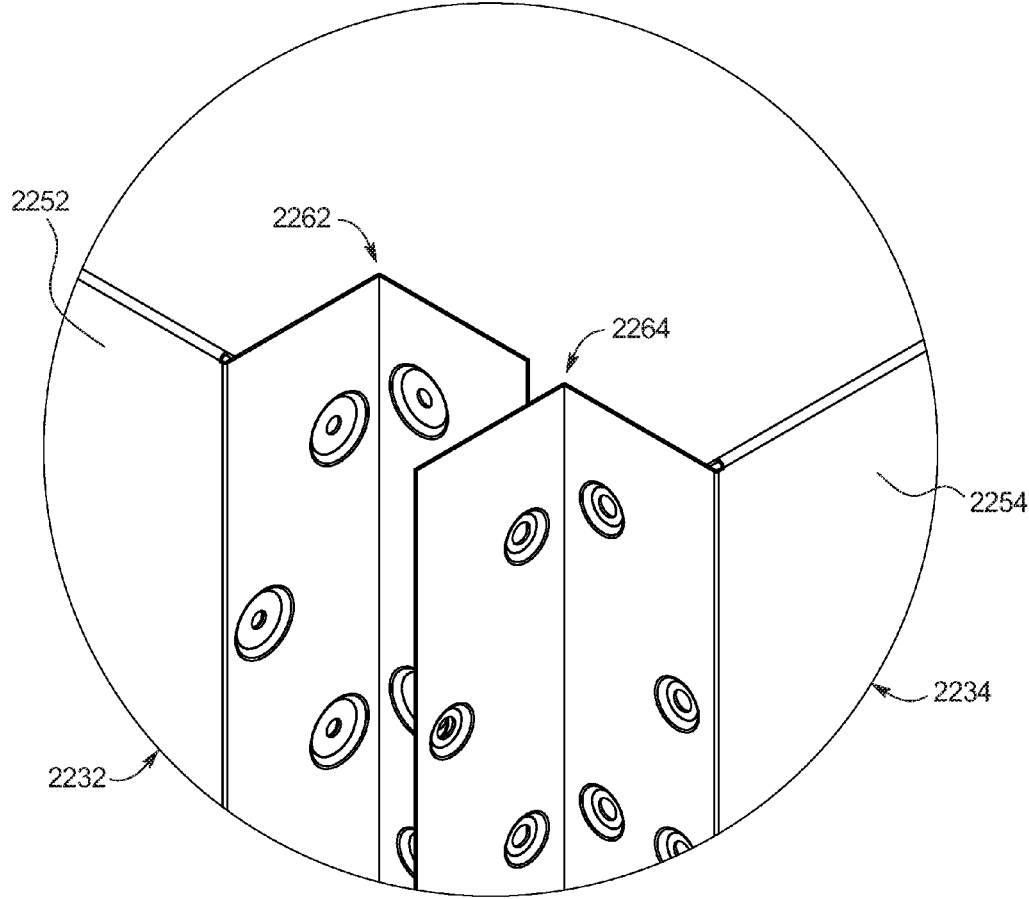

FIG. 81

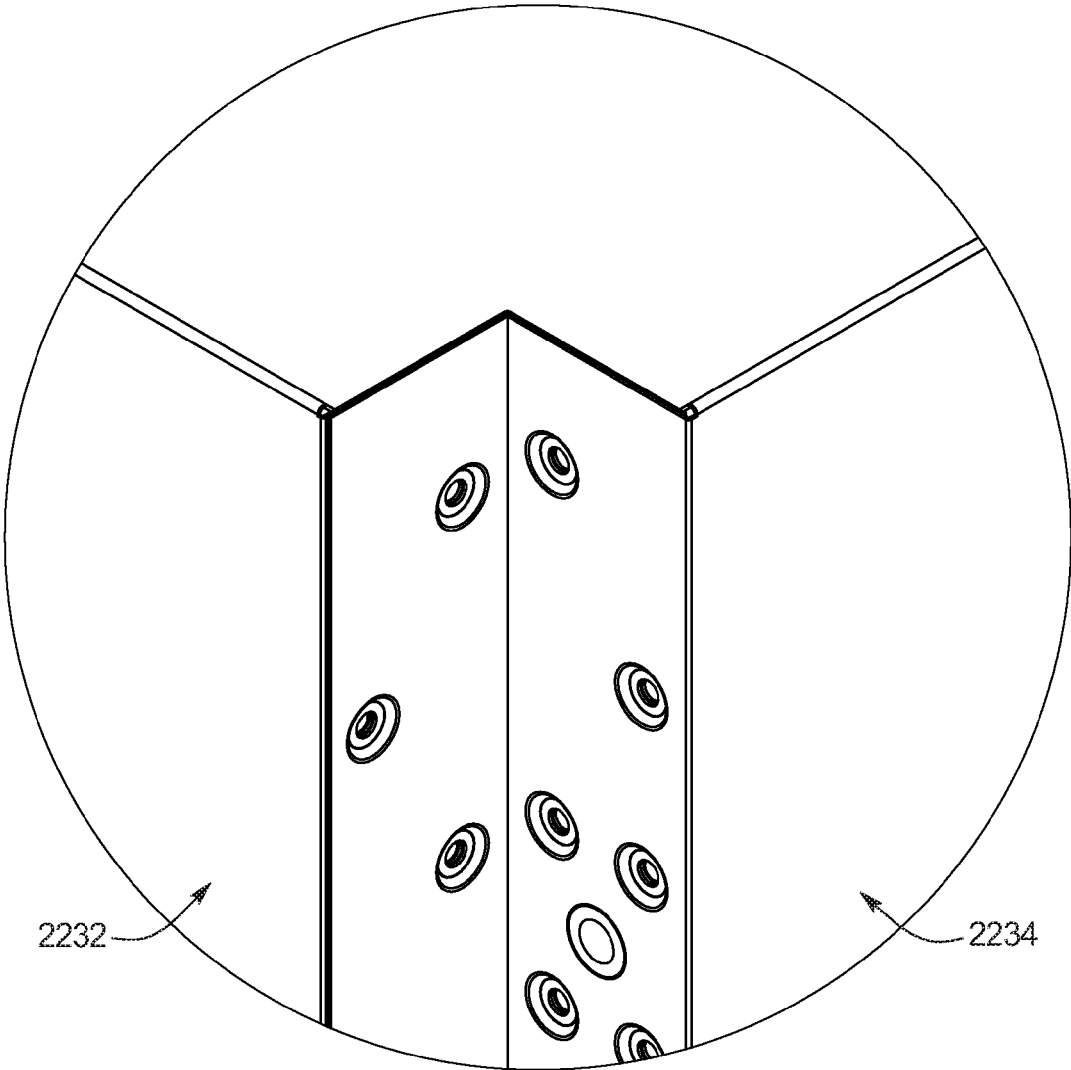

FIG. 82

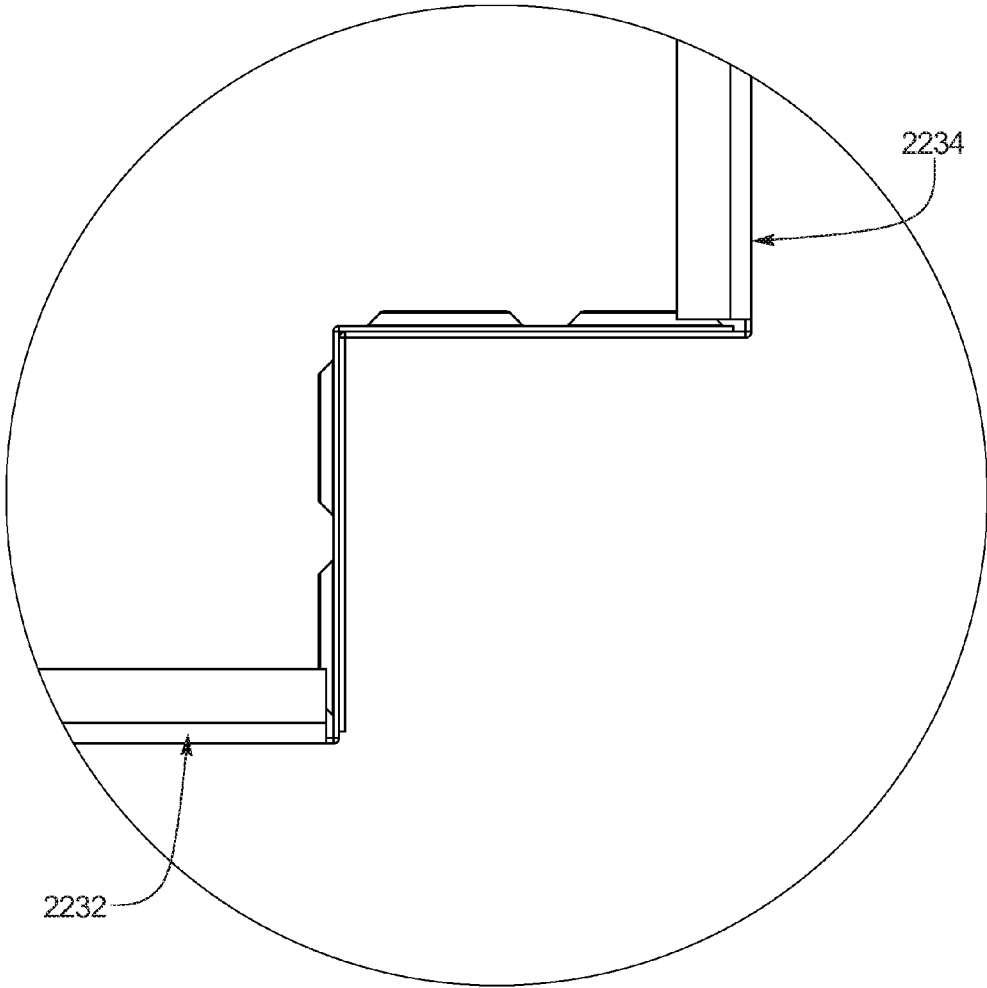

FIG. 83

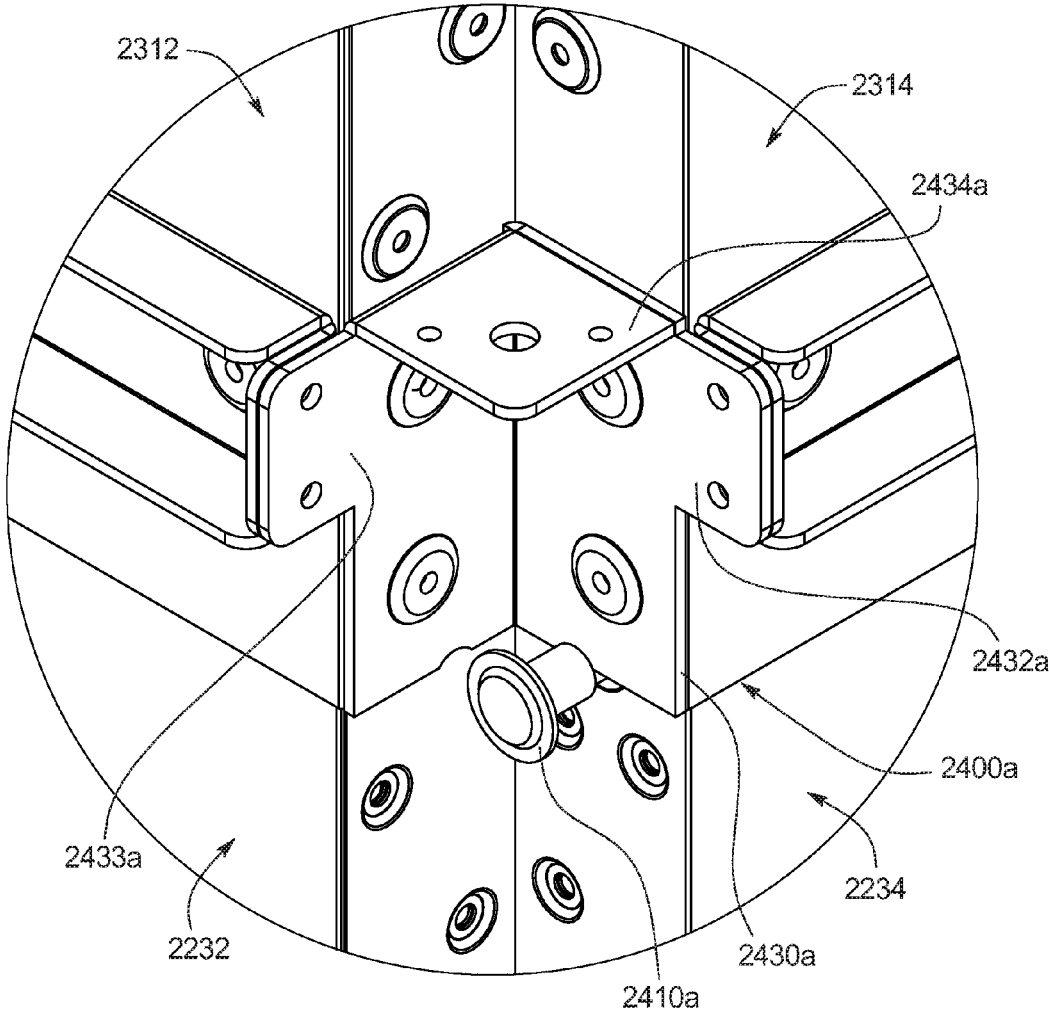

FIG. 84

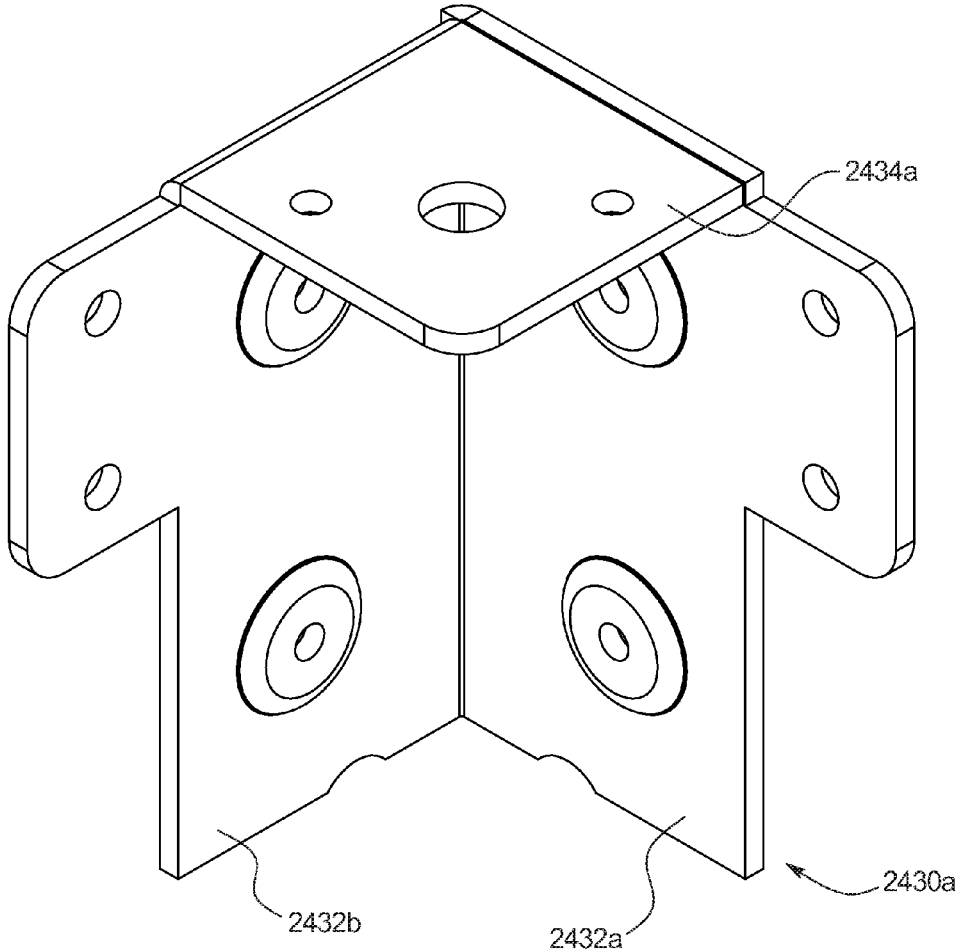

FIG. 85

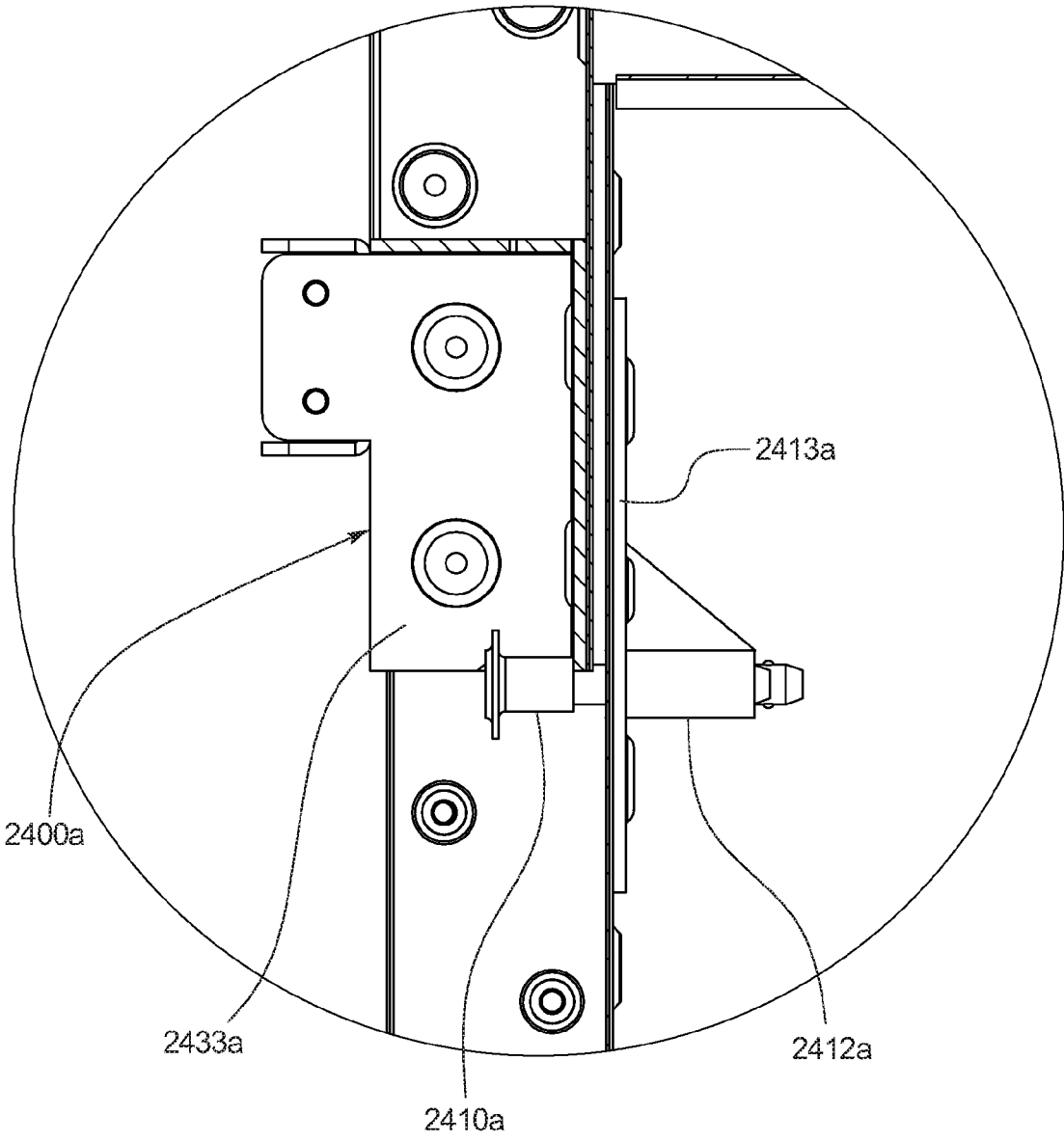

FIG. 86

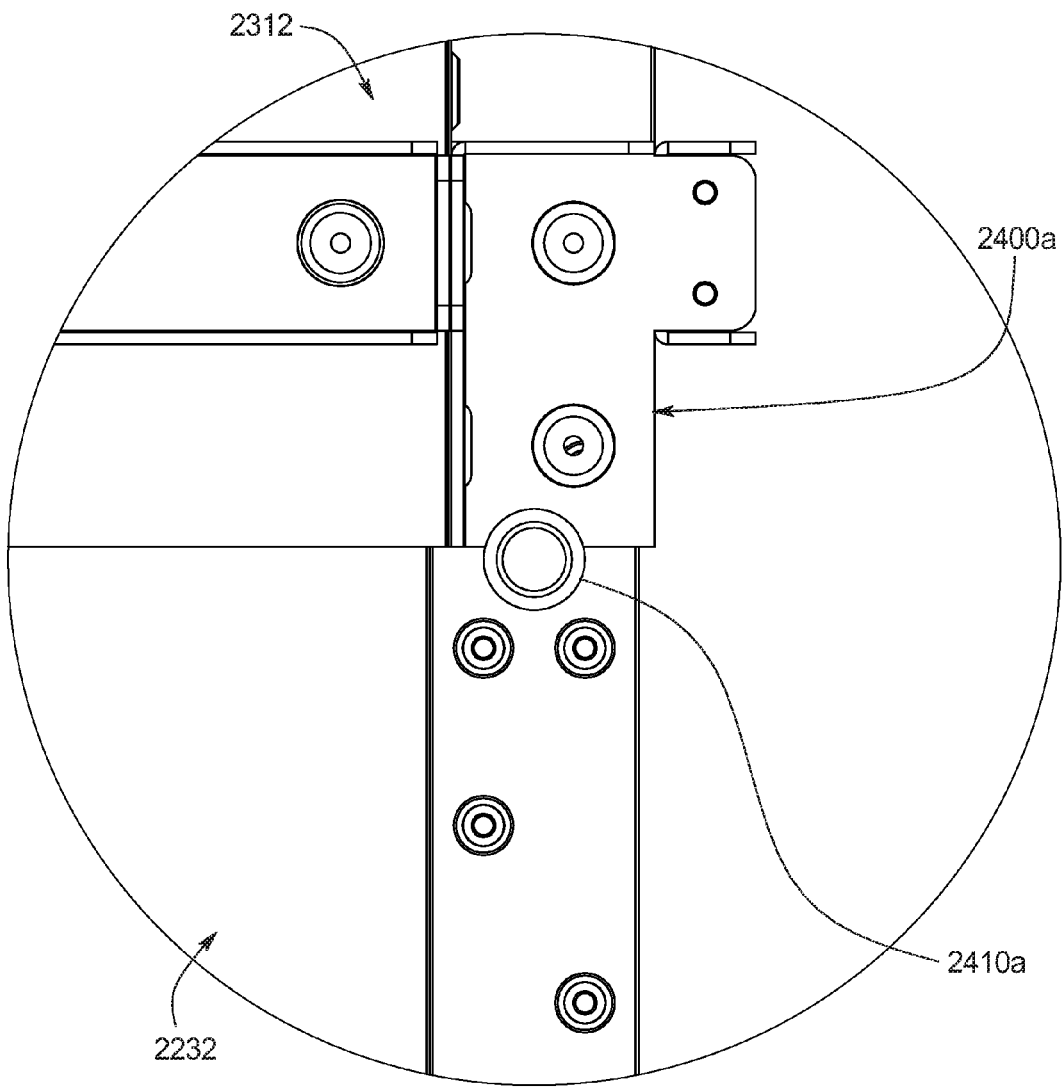

FIG. 87

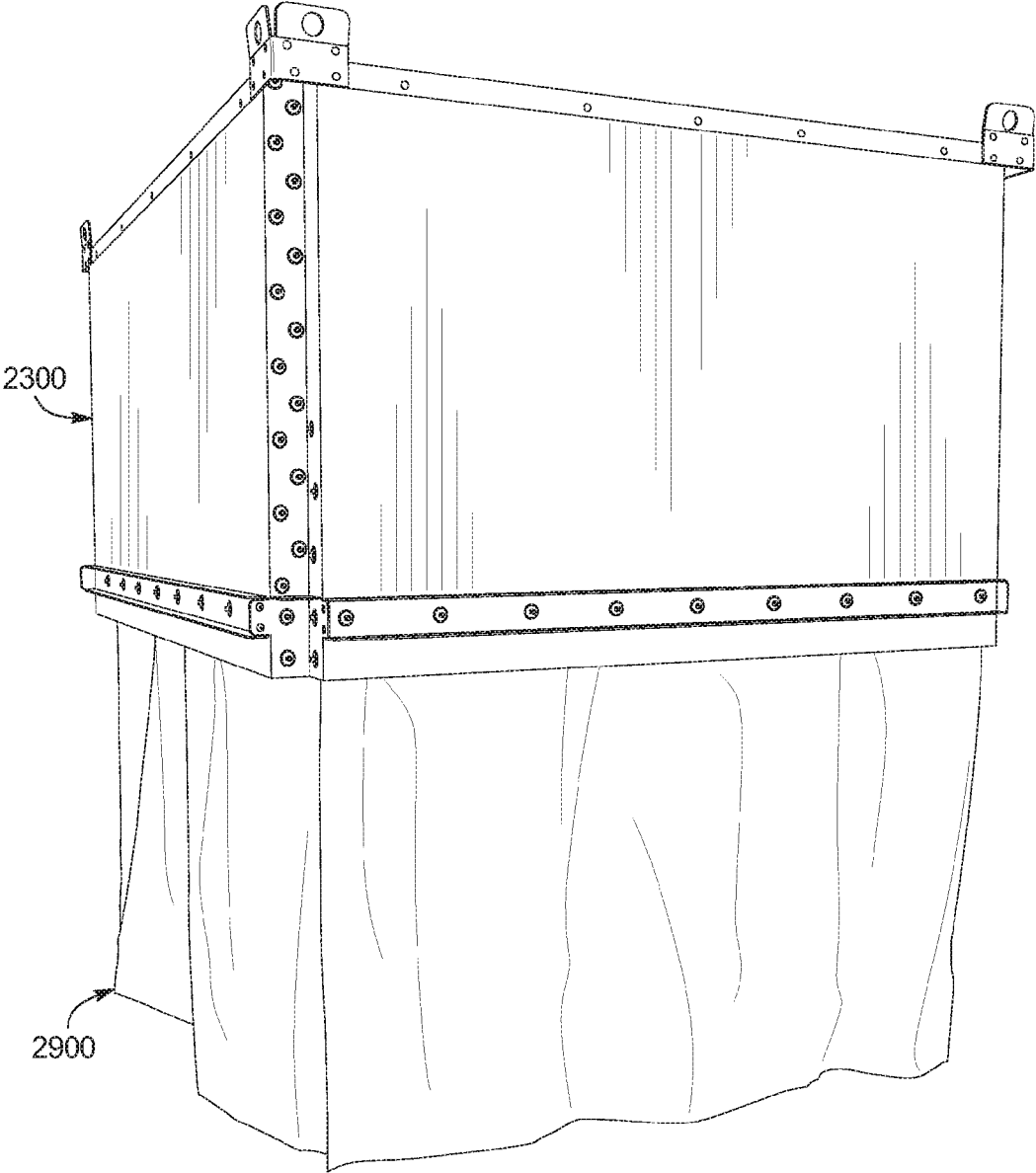

FIG. 88

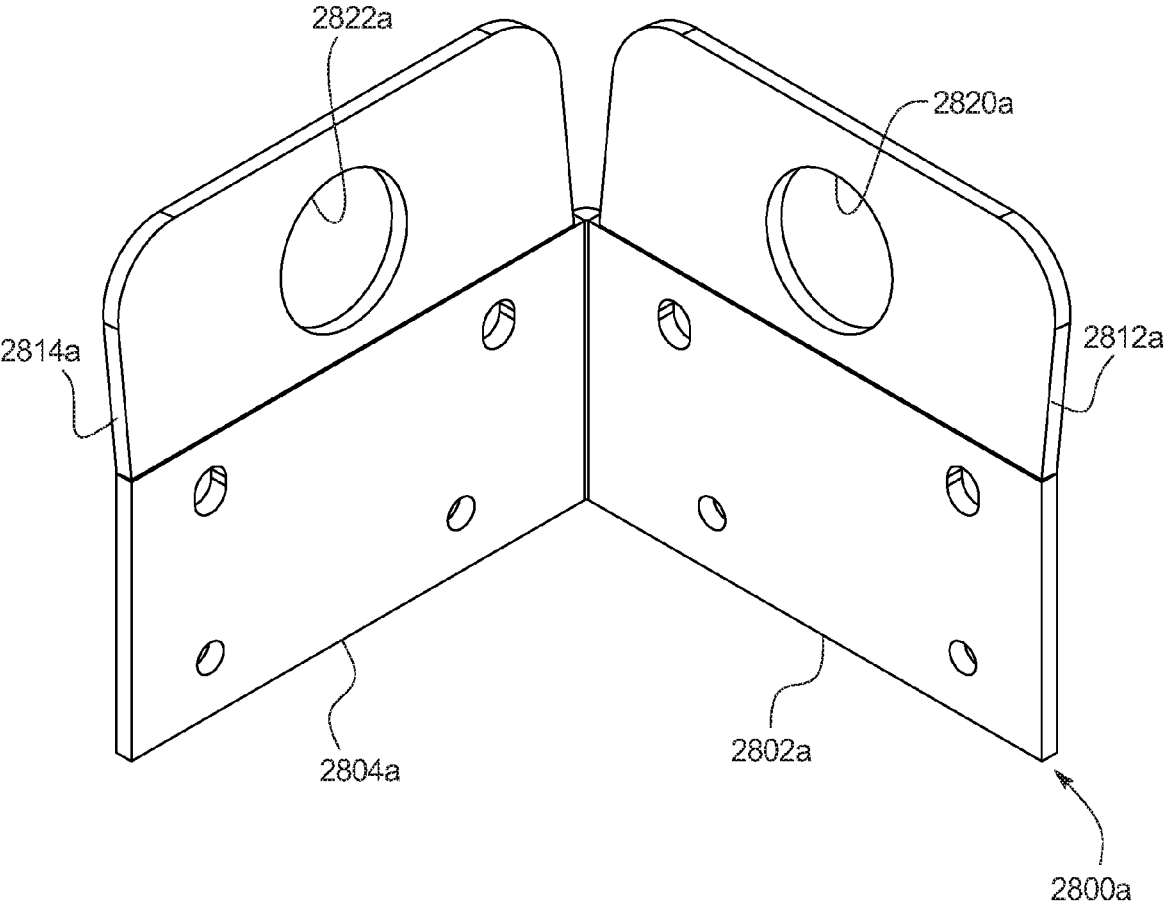

FIG. 89

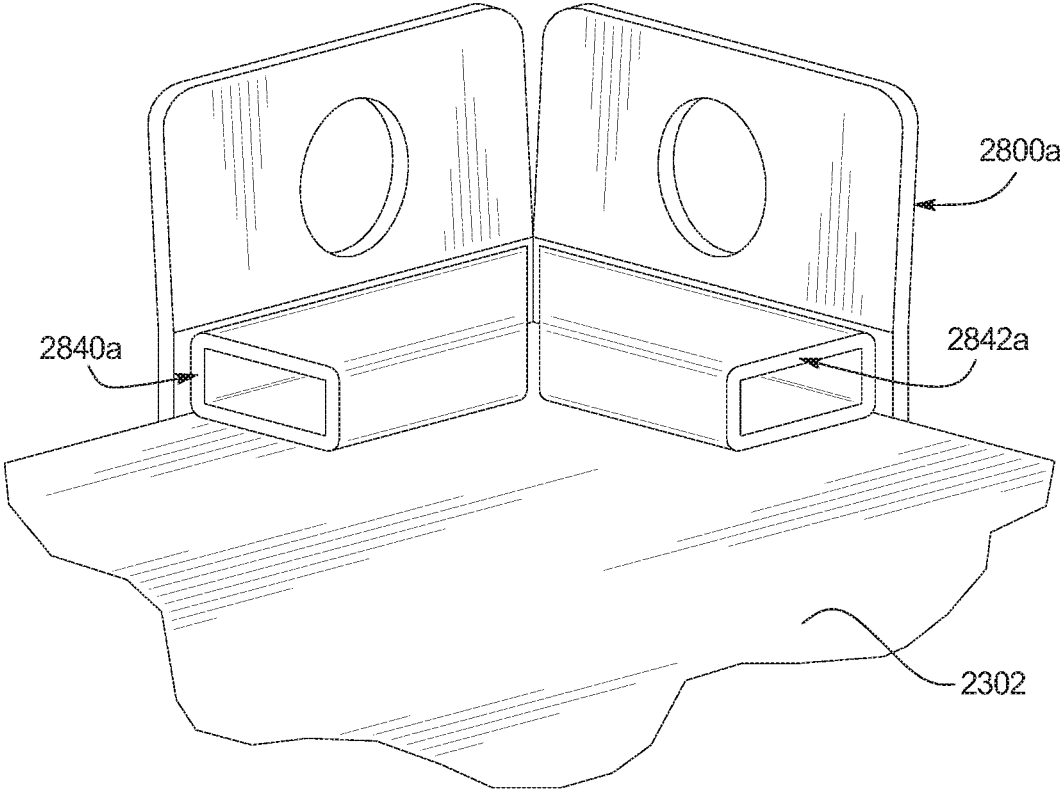
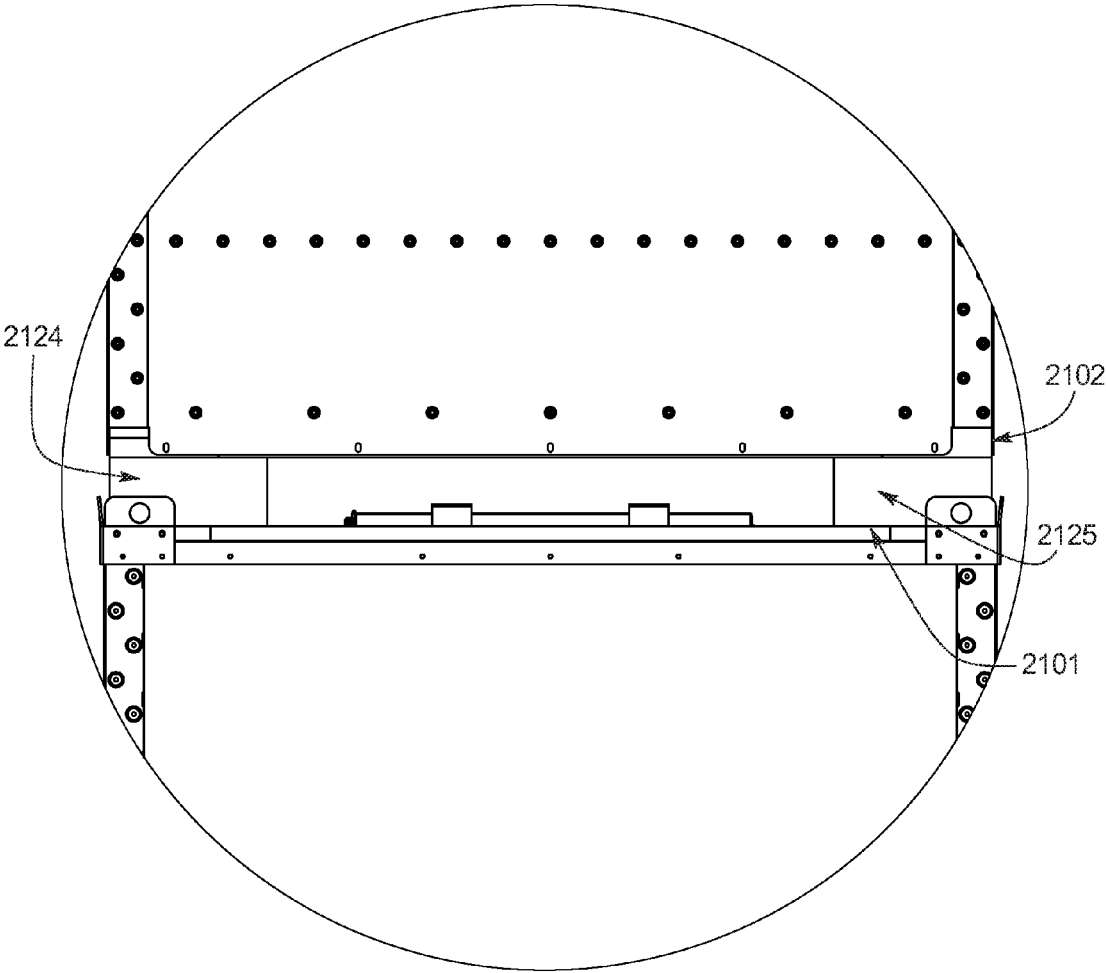

FIG. 90



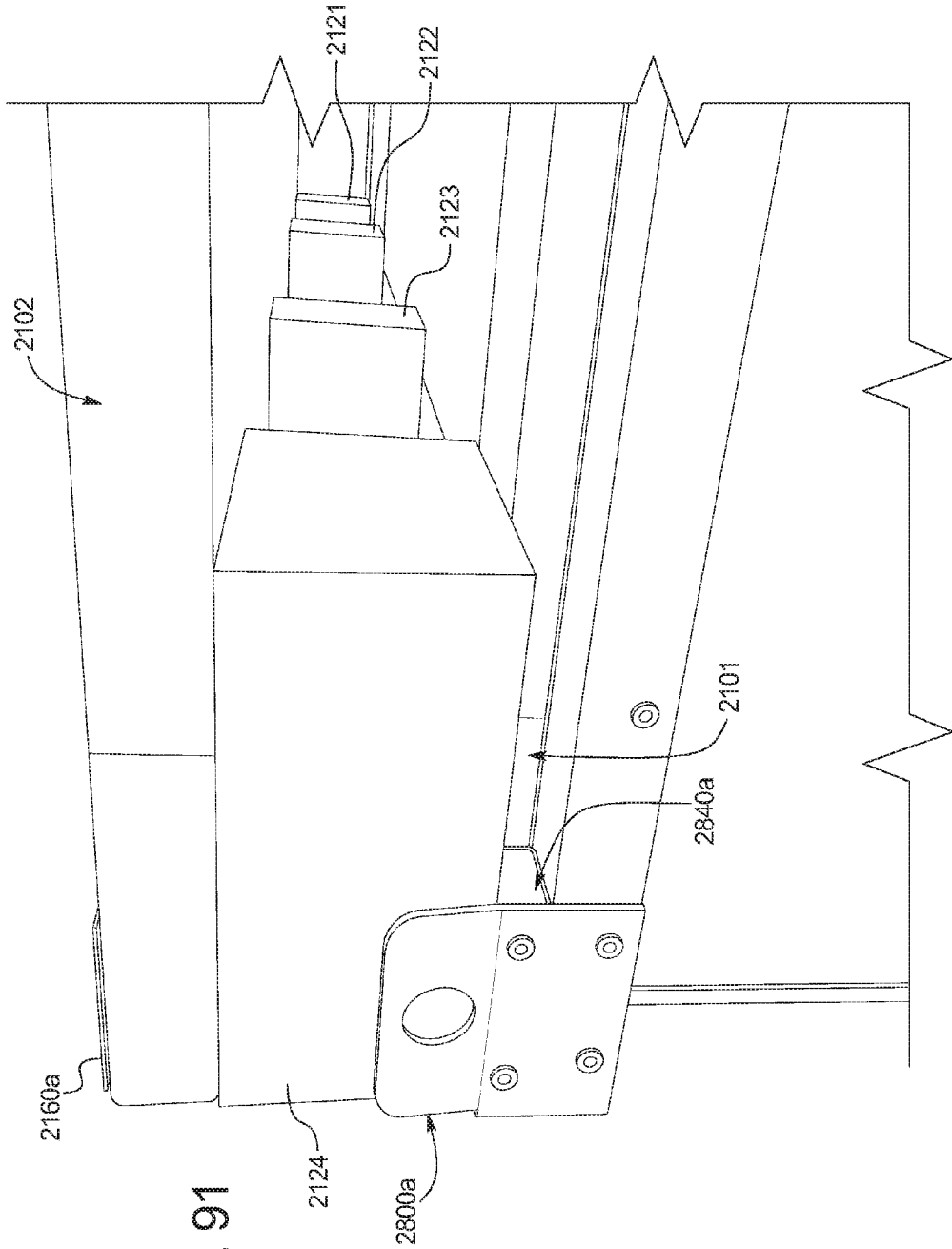
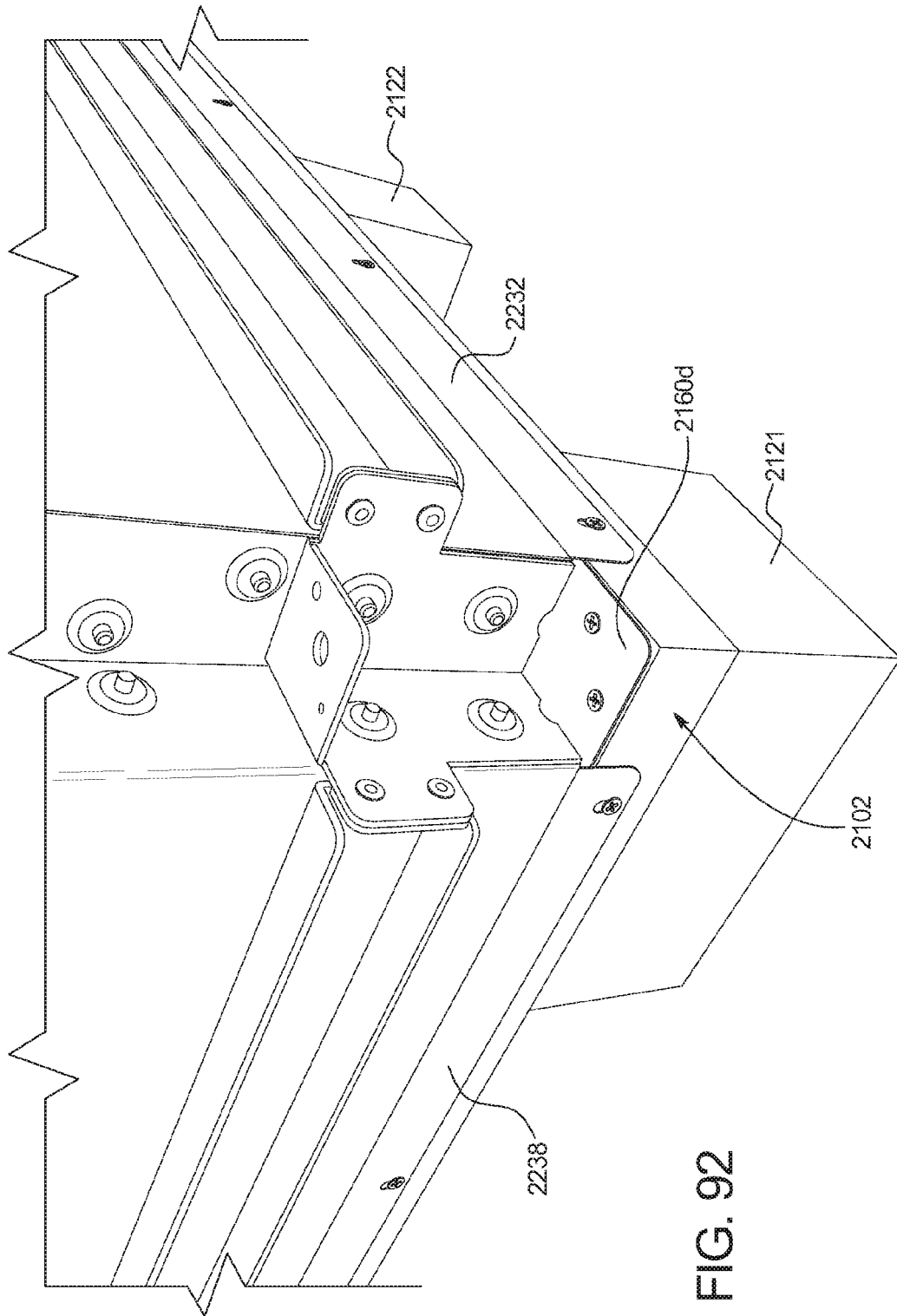

FIG. 91



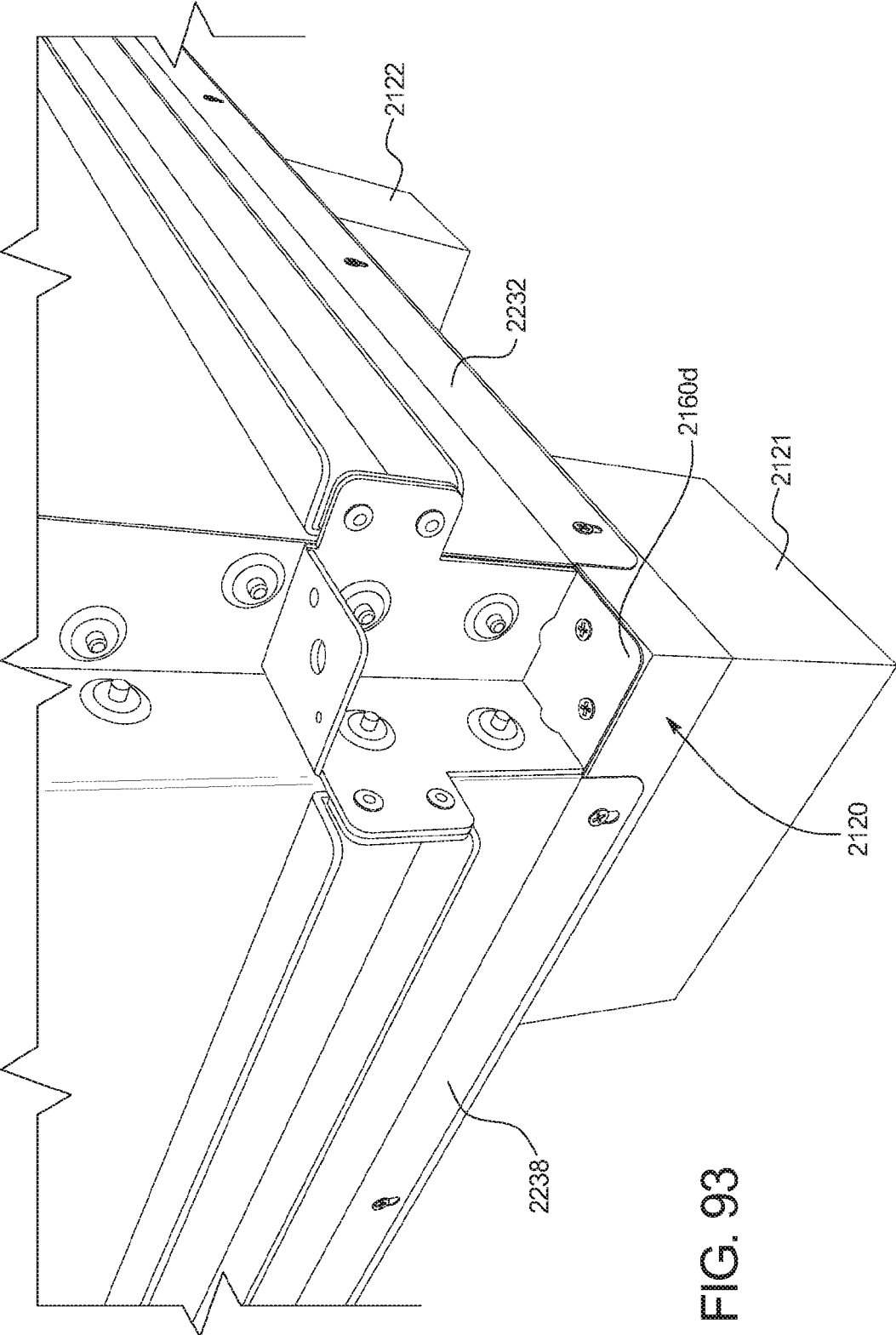

FIG. 93

FIG. 94

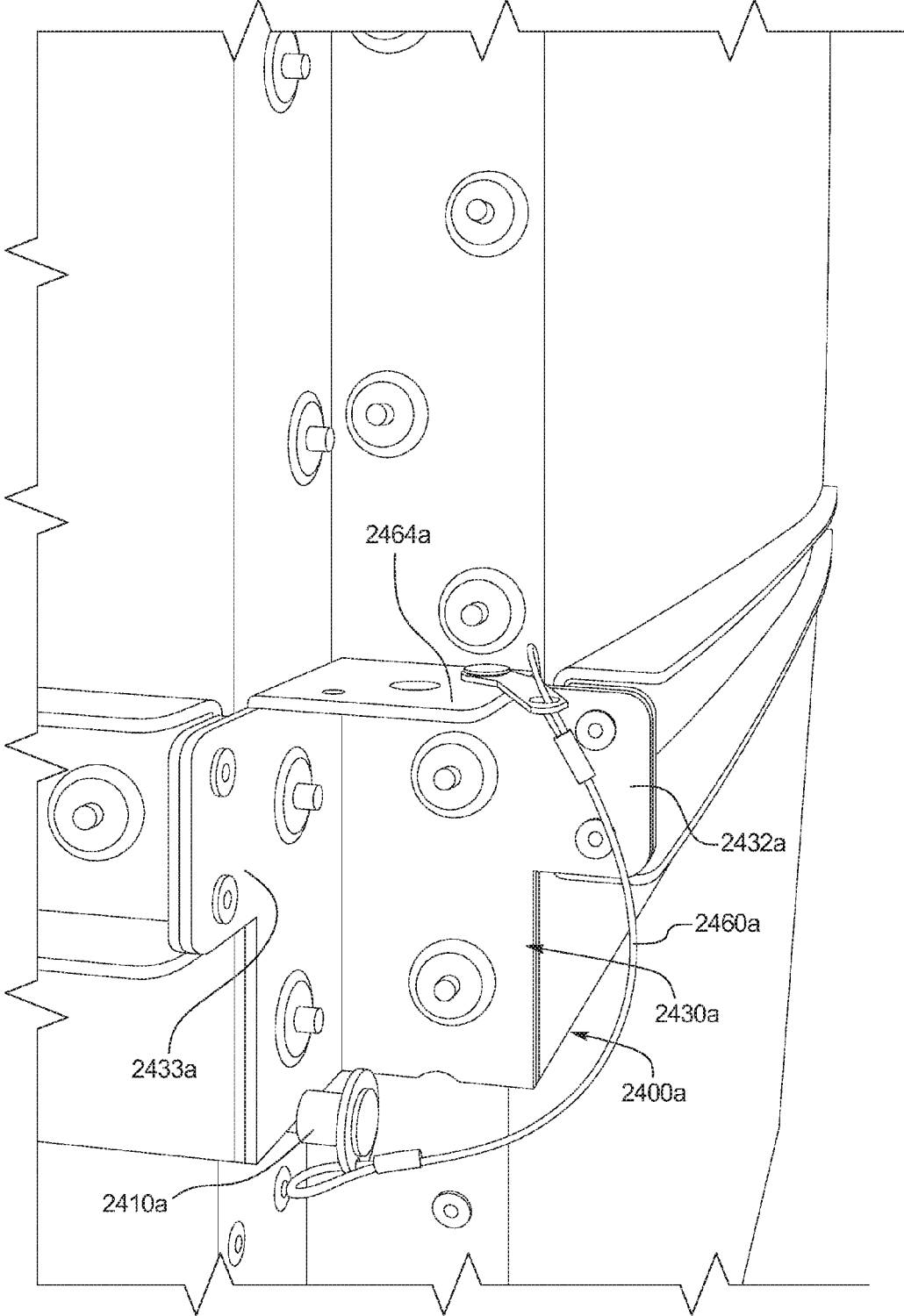
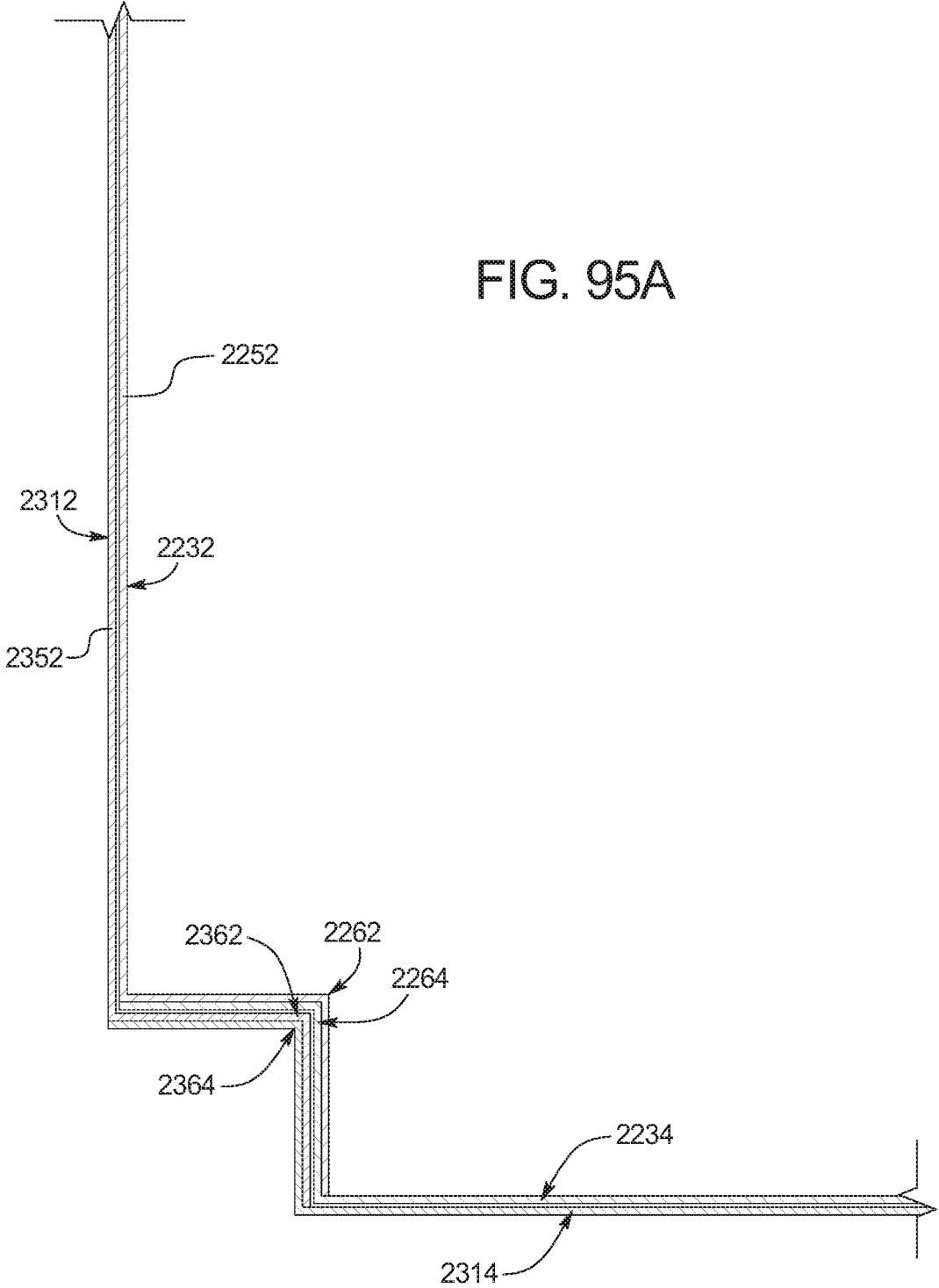

FIG. 95A



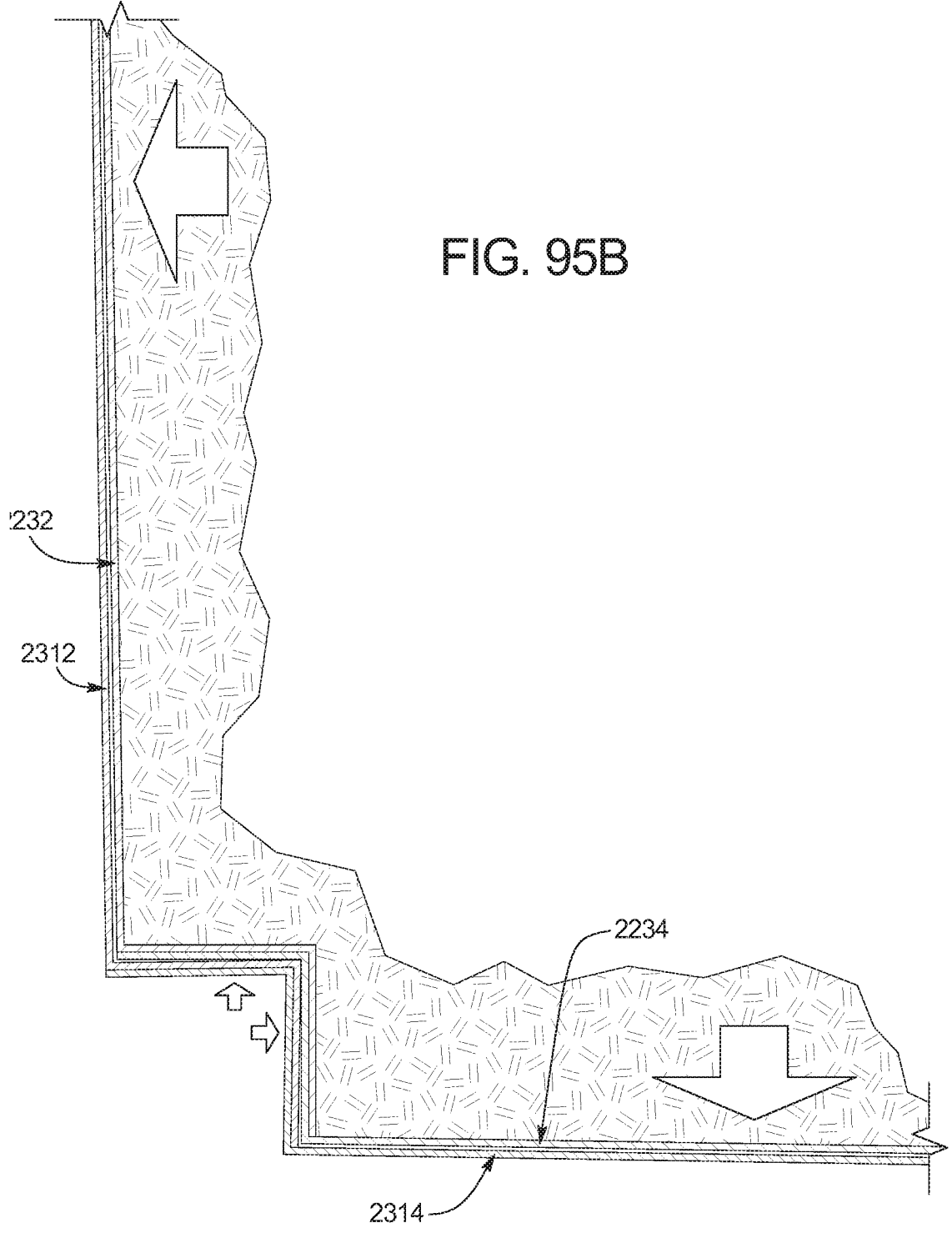
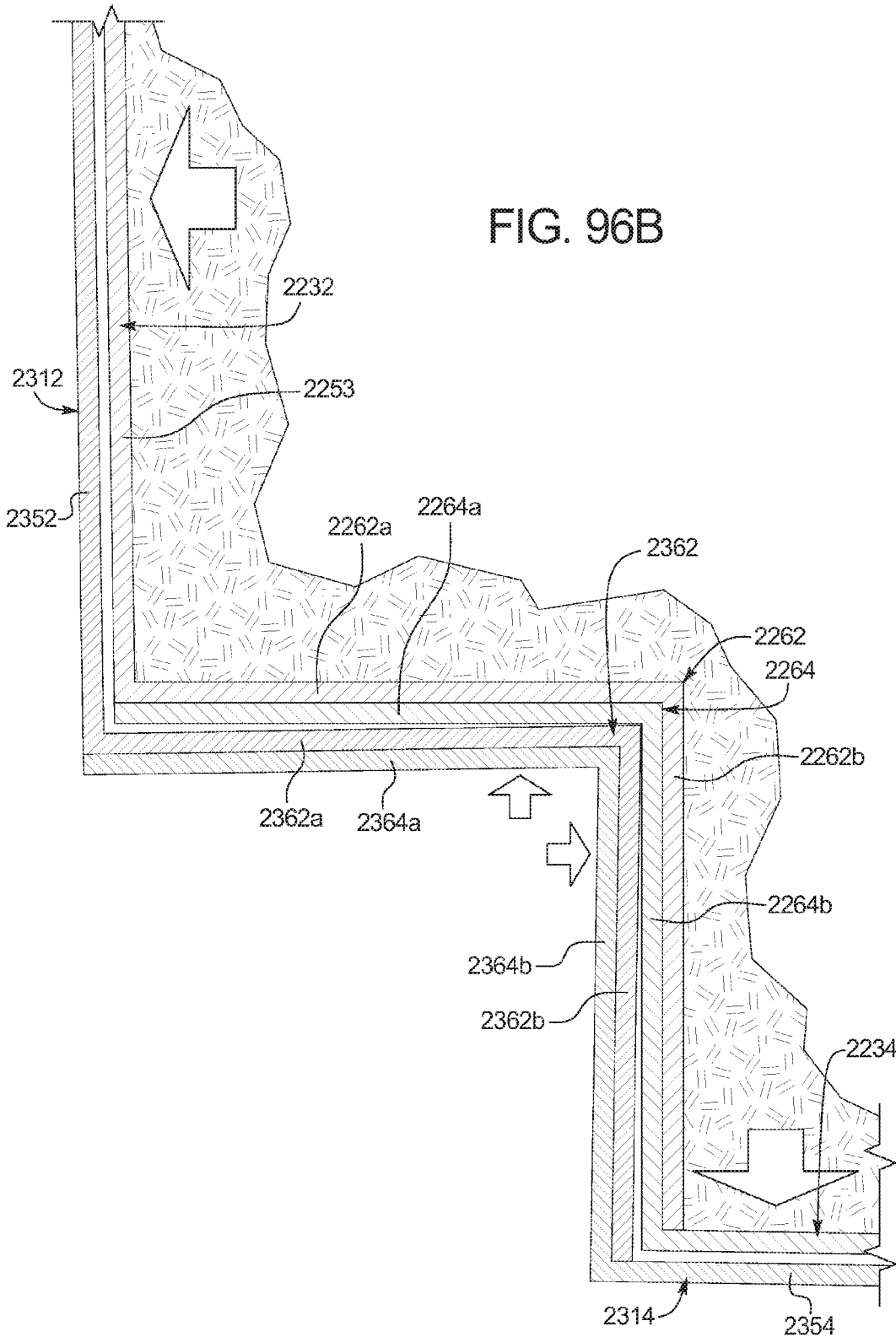
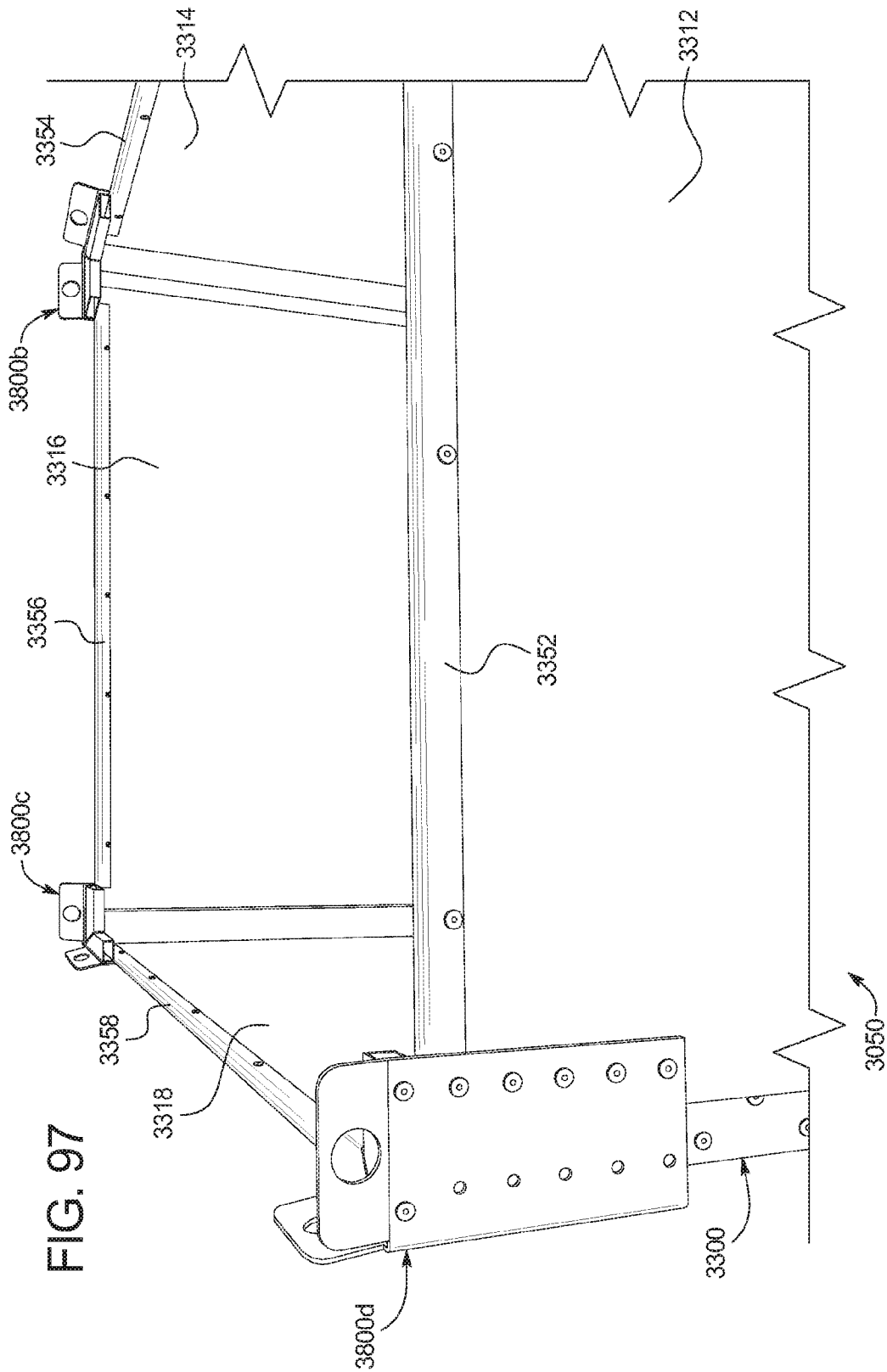

FIG. 96B





BULK MATERIAL SHIPPING CONTAINER

PRIORITY CLAIM

[0001] This application is a continuation patent application of, claims priority to, and the benefit of U.S. patent application Ser. No. 15/634,383, filed Jun. 27, 2017, which is a continuation patent application of, claims priority to and the benefit of U.S. patent application Ser. No. 15/632,696, filed Jun. 26, 2017, which is a continuation patent application of, claims priority to and the benefit of U.S. patent application Ser. No. 15/631,737, filed Jun. 23, 2017, which is a continuation patent application of, claims priority to and the benefit of U.S. patent application Ser. No. 15/471,896, filed Mar. 28, 2017, which is a continuation patent application of, claims priority to and the benefit of U.S. patent application Ser. No. 14/516,292, filed Oct. 16, 2014, which issued on Apr. 11, 2017 as U.S. Pat. No. 9,617,065, which is a continuation patent application of, claims priority to and the benefit of U.S. patent application Ser. No. 13/249,688, filed Sep. 30, 2011, which issued on Nov. 18, 2014 as U.S. Pat. No. 8,887,914, which is a continuation-in-part patent application of, claims priority to, and the benefit of U.S. patent application Ser. No. 12/914,075, filed Oct. 28, 2010, which issued on Dec. 31, 2013, as U.S. Pat. No. 8,616,370, the entire contents of which are incorporated herein by reference.

BACKGROUND

[0002] Various bulk material shipping containers are known. Such known material bulk shipping containers, sometimes referred to herein for brevity as known containers or as known bulk containers, are used to transport a wide range of products, parts, components, items, and materials such as, but not limited to, seeds, shavings, fasteners, and granular materials. These are sometimes called loose materials. There are various disadvantages with such known bulk material shipping containers.

[0003] For example, one known and widely commercially used known bulk container for shipping materials (such as shipping seeds to farms) is sold by Buckhorn Industries. This known bulk container is made from plastic, weighs about 338 pounds (151.9 kilograms), and holds a maximum of 58.3 cubic feet of material. This known container has a bottom section, a top section, and a cover. To use this known container, loaders at a bulk material supplier must remove the cover, remove the top section from the bottom section, flip the top section upside down, place the flipped top section on the bottom section, fill the container, and then place the cover on the flipped top section. This process requires at least two people and a relatively significant amount of time when filling a large quantity of these containers. In certain instances, specifically configured forklift attachments are required to fill and handle this known container. After this known container is shipped to its ultimate destination (such as a farm), the bulk material (such as seed) is unloaded from the container, and the empty container must be shipped back to the material supplier. However, prior to and for shipping back to the supplier, the cover is removed, the flipped top section is removed from the bottom section, the flipped top section is then flipped back over and placed on the bottom section, and the cover is then placed on the top section and fastened with zip ties. This process also requires at least two

people and is relatively time consuming especially for a large quantity of such containers.

[0004] Another disadvantage of this known container is that this container is made from plastic and if one of the three sections (i.e., the bottom, the top, or the cover) is damaged or cracked, that entire section typically must be replaced (instead of being repaired). This adds additional cost, time out of service for the damaged container, and additional material and energy waste.

[0005] Another disadvantage of this known container is that when disassembled (for shipping empty), only two of these containers can be stacked on top of each other and still fit in a conventional shipping container or truck. This tends to leave wasted space in such shipping containers and trucks, and thus increases the overall cost of shipping (including related fuel costs) and energy waste.

[0006] Additional disadvantages of this known container are that: (a) the cover can be easily lost or misplaced; (b) the cover can be easily damaged; (c) this known container is less weather resistant because the cover is readily removable and only attached by zip ties; (d) the insides and outside surfaces are difficult to clean; and (e) a material holding bag is not readily usable with this container, such that this container cannot be used for certain types of loose materials.

[0007] For purposes of brevity, (a) the people who assemble and/or put a container in the position for receiving materials for transport and who load the material in a container are sometimes referred to herein as the “loaders,” and (b) the people who remove the materials from a container and who disassemble and/or put a container in the position for sending back to the supplier are sometimes referred to herein as the “unloaders.”

[0008] Accordingly, there is a need for better bulk material shipping containers which overcome these disadvantages.

SUMMARY

[0009] Various embodiments of the present disclosure provide a bulk material shipping container which overcomes the above described disadvantages with previously known commercially available bulk shipping containers.

[0010] One embodiment of the bulk material shipping container of the present disclosure includes: (a) a pallet; (b) a bottom compartment mounted on and supported by the pallet at numerous different support points; (c) a top compartment mounted on the bottom compartment and movable from a retracted position relative to the bottom compartment (for efficient shipping when not holding materials or holding a relatively small amount of materials) to an expanded position relative to the bottom compartment (for holding extra materials during shipping); (d) a plurality of top compartment supporting assemblies configured to support the top compartment in the expanded position relative to the bottom compartment, and to release the top compartment from the expanded position to enable the top compartment to move downwardly into the retracted position; (e) a material unloading assembly supported by bottom compartment and the pallet; (f) a material loading assembly attached to the top compartment; and (g) an extension assembly attached to the top compartment which enables a user to move the top compartment from the retracted position to the expanded position. The shipping container of the present disclosure is configured to directly hold materials or to receive a suitable plastic bag which holds the materials in the container. It should thus be appreciated that the expandable

and retractable bulk material shipping container of the present disclosure can be used with a bag or without a bag. It should also be appreciated that when a plastic bag is used to hold the materials in the container, the material unloading assembly includes a knife which cuts the bottom of the bag open for unloading of the materials. The bulk material shipping container of the present disclosure is sometimes referred herein for brevity as the container or as the shipping container.

[0011] One embodiment of the shipping container of the present disclosure is primarily made from stainless steel or galvanized steel, except for the pallet which is made from wood. If one of the sections of this embodiment of the container is damaged or cracked, that section can typically be repaired which reduces: (a) cost; (b) time out of service for the container; and (c) additional material and/or energy waste. In alternative embodiments, the pallet of the bulk material shipping container, or certain parts thereof, can be made from a suitably strong plastic material such as a composite material or a fiber glass material.

[0012] One embodiment of the container of the present disclosure can also be stacked three high (when empty) for shipping in conventional transport containers or trucks. This reduces wasted space in such transport containers and trucks and decreases shipping cost and fuel consumption, and thus energy waste.

[0013] One embodiment of the container of the present disclosure holds 72 cubic feet of material and up to about 3125 pounds (1417.5 kilograms). This embodiment of the shipping container has several advantages over the above described known bulk container. Specifically, this embodiment of the bulk container is approximately 65 pounds (29.49 kilograms) lighter, holds approximately 14 cubic feet of additional materials which is approximately 25% more material (such as seeds), is readily repairable, can be stacked three high for more efficient transport to the supplier, and can be moved from the transport or retracted position to the loading or expanded position by one person.

[0014] To load the presently disclosed container, the loaders do not need to remove a cover, remove the top compartment from the bottom compartment, flip the top compartment over, place the flipped top compartment on the bottom compartment, or place any cover on the flipped top compartment. Additionally, the unloaders do not need to remove the cover, remove the flipped top compartment, flip the top compartment, place the top compartment on the bottom compartment, and then place the cover on the top compartment for returning the empty container.

[0015] In another embodiment, the bulk material shipping container of the present disclosure is not expandable or retractable. In one such embodiment, the shipping container includes: (a) a pallet; (b) a bottom compartment mounted on and supported by the pallet at numerous different support points; (c) a top compartment mounted on the bottom compartment; (d) a material unloading assembly supported by the bottom compartment and the pallet; and (e) a material loading assembly attached to the top compartment. In this embodiment, the top compartment is fixed such as by welding to the bottom compartment, and thus this embodiment does not need to include the plurality of top compartment supporting assemblies or the extension assembly attached to the top compartment. In this embodiment, the bulk material shipping container of the present disclosure can be used with a bag or without a bag.

[0016] In another embodiment, the shipping container includes: (a) a pallet; (b) a single compartment mounted on and supported by the pallet at numerous different support points; (c) a material unloading assembly supported by the single compartment and the pallet; and (d) a material loading assembly attached to the single compartment. In this embodiment, since there is a single compartment, this embodiment does not need to include the plurality of top compartment supporting assemblies or the extension assembly attached to a top compartment. In this embodiment, the bulk material shipping container of the present disclosure can also be used with a bag or without a bag.

[0017] In further multi-compartment and single compartment embodiments, instead of a bag, a sleeve is employed in the bulk material shipping container of the present disclosure. In further multi-compartment and single compartment embodiments, the pallet supports the compartments, but does not directly support the material unloading assembly.

[0018] In further embodiments, the bulk material shipping container of the present disclosure is configured without the top wall to provide an open top end.

[0019] It is therefore an advantage of the present disclosure to provide a new and improved bulk material shipping container.

[0020] Additional features and advantages of the present invention are described in, and will be apparent from, the following Detailed Description of Exemplary Embodiments and the figures.

DESCRIPTION OF THE DRAWINGS

[0021] FIG. 1 is a top perspective view of the shipping container of one embodiment of the present disclosure, illustrating the top compartment in the expanded position relative to the bottom compartment.

[0022] FIG. 2 is a top perspective view of the shipping container of FIG. 1, illustrating the top compartment in the retracted or collapsed position relative to the bottom compartment.

[0023] FIG. 3 is a bottom perspective view of the shipping container of FIG. 1, illustrating the top compartment in the expanded position relative to the bottom compartment, and illustrating the legs of the pallet, the fork lift tine receiving channels defined by the pallet, and pallet jack tine receiving channels defined by the pallet.

[0024] FIG. 4 is a front view of the shipping container of FIG. 1, illustrating the top compartment in the expanded position relative to the bottom compartment.

[0025] FIG. 5 is a left side view of the shipping container of FIG. 1, illustrating the top compartment in the expanded position relative to the bottom compartment.

[0026] FIG. 6 is a top view of the shipping container of FIG. 1, illustrating the cover of the material loading assembly of the shipping container in the closed position and the extension assembly attached to the top compartment.

[0027] FIG. 7 is a bottom view of the shipping container of FIG. 1, illustrating the legs of the pallet, the pallet jack tine receiving channels defined by the pallet, and illustrating the chute door or gate of the material unloading assembly in the closed position, and the knife attached to the bottom of the chute door or gate.

[0028] FIG. 8 is an exploded perspective view of the shipping container of FIG. 1 with certain of the smaller components such as the tether removed for ease of illustration.

[0029] FIG. 9 is an enlarged exploded perspective view of the bottom compartment of the shipping container of FIG. 1.

[0030] FIG. 9A is an enlarged exploded top perspective view of the sections of the upper interior bottom wall of the bottom compartment of the shipping container of FIG. 1.

[0031] FIG. 9B is an enlarged top perspective view of the attached sections of the upper interior bottom wall of the bottom compartment of the shipping container of FIG. 1.

[0032] FIG. 9C is an enlarged bottom perspective view of the lower exterior bottom wall of the bottom compartment of the shipping container of FIG. 1, and illustrating the material unloading assembly attached to the bottom of the lower exterior bottom wall.

[0033] FIG. 9D is a further enlarged fragmentary bottom perspective view of the lower exterior bottom wall of the bottom compartment of the shipping container of FIG. 1, and illustrating the material unloading assembly attached to the bottom of the lower exterior bottom wall.

[0034] FIG. 9E is an enlarged top perspective view of the bottom compartment of the shipping container of FIG. 1 with the front and left exterior side walls of the bottom compartment removed to illustrate the lower exterior bottom wall of the bottom compartment, the support gussets of the bottom compartment, and the upper interior bottom wall of the bottom compartment.

[0035] FIG. 9F is an enlarged top perspective view of the bottom compartment and the pallet of the shipping container of FIG. 1 with the front and left exterior side walls of the bottom compartment removed to illustrate the lower exterior bottom wall of the bottom compartment, the support gussets of the bottom compartment, and the upper interior bottom wall of the bottom compartment.

[0036] FIG. 10 is an enlarged top perspective view of the pallet of the shipping container of FIG. 1, shown removed from the container.

[0037] FIG. 10A is an enlarged fragmentary top perspective view of the pallet of the shipping container of FIG. 1, shown removed from the container and without the gate of the material unloading assembly, but with the guide rails of the material unloading assembly shown in the position at which they rest on and are supported by the pallet.

[0038] FIG. 11 is an enlarged top perspective view of the pallet of the shipping container of FIG. 1, shown removed from the container, and illustrating the certain of the legs of the pallet in phantom, certain portions of the fork lift tine receiving channels of the pallet in phantom, and certain portions of the pallet jack tine receiving channels defined by the pallet in phantom.

[0039] FIG. 12 is an enlarged bottom perspective view of the pallet of the shipping container of FIG. 1, shown removed from the container and flipped upside down, and illustrating the certain of the legs of the pallet, certain portions of the fork lift tine receiving channels defined by the pallet in phantom, and the pallet jack tine receiving channels defined by the pallet.

[0040] FIG. 13 is an enlarged bottom view of the pallet of the shipping container of FIG. 1, shown removed from the container and illustrating certain of the legs of the pallet, and the pallet jack tine receiving channels defined by the pallet.

[0041] FIG. 14 is an enlarged top fragmentary perspective view of a part of the central portion of the pallet of the shipping container of FIG. 1, shown removed from the container, and illustrating the position of the guide rails and the gate of the material unloading assembly detached from

the bottom compartment, in the closed position, and in the position at which they rest on and are supported by the pallet.

[0042] FIG. 15 is an enlarged top fragmentary perspective view of a part of the central portion of the pallet of the shipping container of FIG. 1, shown removed from the container and illustrating the guide rails and the gate of the material unloading assembly detached from the bottom compartment, in a partially open position with the blade of the knife extending partially upwardly through the gate, and in the position at which they rest on and are supported by the pallet.

[0043] FIG. 16 is an enlarged top fragmentary perspective view of a part of the central portion of the pallet of the shipping container of FIG. 1, shown removed from the container and illustrating the guide rails and the gate of the material unloading assembly detached from the bottom compartment, in a fully open position with the blade of the knife extending fully upwardly through the gate, and in the position at which they rest on and are supported by the pallet.

[0044] FIG. 17 is an enlarged fragmentary cross-sectional view of a part of the central portion of the pallet and a part of the bottom compartment of the shipping container of FIG. 1, and illustrating the gate of the material unloading assembly in a fully closed position and the blade of the knife in the fully closed and non-extended position.

[0045] FIG. 17A is an even further enlarged fragmentary cross-sectional view of a part of the central portion of the pallet and a part of the bottom compartment of the shipping container of FIG. 1, and illustrating the gate of the material unloading assembly in a fully closed position and the blade of the knife in the fully closed and non-extended position.

[0046] FIG. 18 is an enlarged fragmentary cross-sectional view of a part of the central portion of the pallet and a part of the bottom compartment of the shipping container of FIG. 1, and illustrating the gate of the material unloading assembly in a partially open position and the blade of the knife extending partially upwardly through the gate.

[0047] FIG. 18A is an even further enlarged fragmentary cross-sectional view of a part of the central portion of the pallet and a part of the bottom compartment of the shipping container of FIG. 1, and illustrating the gate of the material unloading assembly in a partially open position and the blade of the knife extending partially upwardly through the gate.

[0048] FIG. 19 is an enlarged fragmentary cross-sectional view of the central portion of the pallet and a part of the bottom compartment of the shipping container of FIG. 1, and illustrating the gate of the material unloading assembly in a fully open position and the blade of the knife extending fully upwardly through the gate.

[0049] FIG. 19A is an even further enlarged fragmentary cross-sectional view of the central portion of the pallet and a part of the bottom compartment of the shipping container of FIG. 1, and illustrating the gate of the material unloading assembly in a fully open position and the blade of the knife extending fully upwardly through the gate.

[0050] FIG. 20A is an enlarged perspective view of the gate of the material unloading assembly of the shipping container of FIG. 1.

[0051] FIG. 20B is an enlarged top plan view of the gate of the material unloading assembly of the shipping container of FIG. 1.

[0052] FIG. 20C is an enlarged side view of the gate of the material unloading assembly of the shipping container of FIG. 1.

[0053] FIG. 20D is an enlarged side view of the gate and knife of the material unloading assembly of the shipping container of FIG. 1.

[0054] FIG. 21 is an enlarged rear perspective view of the knife of the material unloading assembly of the shipping container of FIG. 1.

[0055] FIG. 22 is an enlarged right side view of the knife of the material unloading assembly of the shipping container of FIG. 1.

[0056] FIG. 23 is an enlarged end view of the cutting edge of the knife of the material unloading assembly of the shipping container of FIG. 1.

[0057] FIG. 24 is an enlarged fragmentary perspective view of the central portion of the pallet and a part of the bottom compartment of the shipping container of FIG. 1, and illustrating the locking pin and the handle of the gate of the material unloading assembly in an open position.

[0058] FIG. 25 is an enlarged fragmentary perspective view of the central portion of the pallet and a part of the bottom compartment of the shipping container of FIG. 1, and illustrating the locking pin of the handle of the gate of the material unloading assembly.

[0059] FIG. 26 is an enlarged fragmentary perspective view of the central portion of the pallet and a part of the bottom compartment of the shipping container of FIG. 1, and illustrating the locking pin of the handle of the gate of the material unloading assembly.

[0060] FIG. 27A is an enlarged fragmentary exploded perspective view of the corner wall construction of the bottom compartment of the shipping container of FIG. 1, and illustrating the corners before being attached.

[0061] FIG. 27B is an enlarged fragmentary perspective view of the corner wall construction of the bottom compartment of the shipping container of FIG. 1, and illustrating the corners after being attached.

[0062] FIG. 27C is an enlarged fragmentary top plan view of the corner wall construction of the bottom compartment of the shipping container of FIG. 1, and illustrating the corners after being attached.

[0063] FIG. 28 is an enlarged fragmentary perspective view of one of the top compartment support assemblies of the shipping container of FIG. 1, illustrating the locking pin of the assembly inserted in the pin receipt in a corner of the bottom compartment, the pin holder attached to a corner of the top compartment, and a tether connecting the locking pin to the pin holder.

[0064] FIG. 29 is an enlarged perspective view of one of the locking pin holders of one of the top compartment support assemblies of the shipping container of FIG. 1, shown removed from the top compartment of the container.

[0065] FIG. 30 is an enlarged perspective view of one of the locking pins and tethers of one of the top compartment support assemblies of the shipping container of FIG. 1.

[0066] FIG. 31 is an enlarged fragmentary partially cut away view of one of the locking pins of one of the top compartment support assemblies inserted in a pin receipt of one of the corners of the bottom compartment of the shipping container of FIG. 1, and illustrating the locking pin in a locked position and supporting the corner of the top compartment.

[0067] FIG. 32 is an enlarged fragmentary view of one of the locking pins of one of the top compartment support assemblies inserted in a pin receipt of one of the corners of the bottom compartment of the shipping container of FIG. 1.

[0068] FIG. 33 is an enlarged perspective view of one of the fork lift receiving tines or lifting brackets of the extension assembly of the shipping container of FIG. 1.

[0069] FIG. 34 is a left side view of the shipping container of FIG. 1, illustrating the top compartment in the expanded position relative to the bottom compartment, and the cover of the material unloading assembly in an open position.

[0070] FIG. 35 is a top perspective view of the top wall of the top compartment of the shipping container of FIG. 1, shown removed from the top compartment and illustrating the opening in the top wall and the lip of the material loading assembly extending from the top wall and which is configured to be securely engaged by the cover of the material loading assembly.

[0071] FIG. 36 is a top perspective view of the cover of the material loading assembly of the shipping container of FIG. 1, shown removed from the top compartment and illustrating in phantom the channel of the cover which is configured to receive the lip of the material loading assembly attached to the top compartment for secure engagement by the cover.

[0072] FIG. 37 is an enlarged fragmentary perspective view of the locking assembly of the material loading assembly of the shipping container of FIG. 1, shown in the closed position.

[0073] FIG. 38 is an enlarged perspective view of one of the nesting or stacking guides of the shipping container of FIG. 1, shown removed from the top compartment and illustrating the bag end holders defined by the nesting or stacking guides.

[0074] FIG. 39 is an enlarged fragmentary side view of a portion of the top compartment of a first shipping container of FIG. 1 and a portion of the pallet and lower compartment of a second shipping container of FIG. 1 shown stacked on the top compartment of the first shipping container.

[0075] FIG. 40 is an enlarged fragmentary perspective view of a portion of the top compartment of a first shipping container of FIG. 1 and a pallet of a second shipping container of FIG. 1 shown stacked on the top compartment of the first shipping container.

[0076] FIG. 41 is a perspective view of the shipping container of FIG. 1 and a bag positioned over the stacking guides, and with the cover of the material loading assembly removed for ease of illustration.

[0077] FIG. 42 is a perspective view of the shipping container of FIG. 1 and a bag positioned with its ends extending through the stacking guides, and with the cover of the material loading assembly removed for ease of illustration.

[0078] FIG. 43 is a perspective view of the shipping container of FIG. 1 and a bag holder of one embodiment of the present disclosure which is configured to hold a roll of bags.

[0079] FIG. 44 is a perspective view of the shipping container of FIG. 1 and the bag holder of FIG. 43, and illustrating how the bag holder of FIG. 43 holds one of the bags over the shipping container during the material loading process, and with the cover of the material loading assembly removed for ease of illustration.

[0080] FIG. 45 is a perspective view of the shipping container of FIG. 1 and another embodiment of a bag holder of the present disclosure.

[0081] FIG. 46 is a perspective view of the shipping container of FIG. 1 and the bag holder of FIG. 45, and illustrating how the bag holder of FIG. 43 holds one of the bags over the shipping container during the material loading process, and with the cover of the material loading assembly removed for ease of illustration.

[0082] FIG. 47 is a perspective view of another example embodiment of the shipping container of the present disclosure, illustrating the top compartment in the expanded position relative to the bottom compartment.

[0083] FIG. 48 is a top perspective view of the shipping container of FIG. 47, illustrating the top compartment in the retracted or collapsed position relative to the bottom compartment.

[0084] FIG. 49 is a bottom perspective view of the shipping container of FIG. 47, illustrating the top compartment in the expanded position relative to the bottom compartment, and illustrating the pallet of this embodiment of the shipping container of FIG. 47.

[0085] FIG. 50 is a front view of the shipping container of FIG. 47, illustrating the top compartment in the expanded position relative to the bottom compartment.

[0086] FIG. 51 is a left side view of the shipping container of FIG. 47, illustrating the top compartment in the expanded position relative to the bottom compartment.

[0087] FIG. 52 is a top view of the shipping container of FIG. 47, illustrating the cover of the material loading assembly of the shipping container in the closed position and the extension assembly attached to the top compartment.

[0088] FIG. 53 is a bottom view of the shipping container of FIG. 47, illustrating the pallet, and further illustrating the chute door or gate of the material unloading assembly in the closed position.

[0089] FIG. 54 is an exploded perspective view of the shipping container of FIG. 47 with certain of the smaller components removed for ease of illustration.

[0090] FIG. 55 is an enlarged exploded perspective view of the bottom compartment of the shipping container of FIG. 47.

[0091] FIG. 56 is an enlarged exploded top perspective view of the sections of the upper interior bottom wall of the bottom compartment of the shipping container of FIG. 47.

[0092] FIG. 57 is an enlarged top perspective view of the attached sections of the upper interior bottom wall of the bottom compartment of the shipping container of FIG. 47.

[0093] FIG. 58 is an enlarged bottom perspective view of the lower exterior bottom wall of the bottom compartment of the shipping container of FIG. 47, and illustrating the material unloading assembly attached to the bottom of the lower exterior bottom wall.

[0094] FIG. 59 is a further enlarged fragmentary bottom perspective view of the lower exterior bottom wall of the bottom compartment of the shipping container of FIG. 47, and illustrating the material unloading assembly attached to the bottom of the lower exterior bottom wall.

[0095] FIG. 60 is an enlarged top perspective view of the pallet of the shipping container of FIG. 47, shown removed from the bottom compartment of the container and without the gate of the material unloading assembly, but with the guide rails of the material unloading assembly shown in their position relative to the pallet.

[0096] FIG. 61 is an enlarged fragmentary top perspective view of the pallet of the shipping container of FIG. 47, shown removed from the bottom compartment of the container and without the gate of the material unloading assembly, but with the guide rails of the material unloading assembly shown in their position relative to the pallet.

[0097] FIG. 62 is an enlarged top perspective view of the pallet of the shipping container of FIG. 47, shown removed from the bottom compartment of the container, and illustrating certain portions of the pallet in phantom.

[0098] FIG. 63 is an enlarged bottom perspective view of the pallet of the shipping container of FIG. 47, shown removed from the bottom compartment of the container and flipped upside down, and illustrating the certain portions of the pallet in phantom.

[0099] FIG. 64 is an enlarged bottom view of the pallet of the shipping container of FIG. 47, shown removed from the bottom compartment of the container.

[0100] FIG. 65 is an enlarged fragmentary top perspective view of a part of the central portion of the pallet of the shipping container of FIG. 47, shown removed from the bottom compartment of the container, and illustrating the position of the guide rails and the gate of the material unloading assembly detached from the bottom compartment and with the gate in the closed position.

[0101] FIG. 66 is an enlarged fragmentary top perspective view of a part of the central portion of the pallet of the shipping container of FIG. 47, shown removed from the bottom compartment of the container and illustrating the guide rails and the gate of the material unloading assembly detached from the bottom compartment and with the gate in a partially open position.

[0102] FIG. 67 is an enlarged fragmentary top perspective view of a part of the central portion of the pallet of the shipping container of FIG. 47, shown removed from the bottom compartment of the container and illustrating the guide rails and the gate of the material unloading assembly detached from the bottom compartment and with the gate in a fully open position.

[0103] FIG. 68 is an enlarged fragmentary cross-sectional view of a part of the central portion of the pallet and a part of the bottom compartment of the shipping container of FIG. 47, and illustrating the gate of the material unloading assembly in a fully closed position.

[0104] FIG. 69 is an even further enlarged fragmentary cross-sectional view of a part of the central portion of the pallet and a part of the bottom compartment of the shipping container of FIG. 47, and illustrating the gate of the material unloading assembly in a fully closed position.

[0105] FIG. 70 is an enlarged fragmentary cross-sectional view of a part of the central portion of the pallet and a part of the bottom compartment of the shipping container of FIG. 47, and illustrating the gate of the material unloading assembly in a partially open position.

[0106] FIG. 71 is an even further enlarged fragmentary cross-sectional view of a part of the central portion of the pallet and a part of the bottom compartment of the shipping container of FIG. 47, and illustrating the gate of the material unloading assembly in a partially open position.

[0107] FIG. 72 is an enlarged fragmentary cross-sectional view of the central portion of the pallet and a part of the bottom compartment of the shipping container of FIG. 47, and illustrating the gate of the material unloading assembly in a fully open position.

[0108] FIG. 73 is an even further enlarged fragmentary cross-sectional view of the central portion of the pallet and a part of the bottom compartment of the shipping container of FIG. 47, and illustrating the gate of the material unloading assembly in a fully open position.

[0109] FIG. 74 is an enlarged perspective view of the gate of the material unloading assembly of the shipping container of FIG. 47.

[0110] FIG. 75 is an enlarged top view of the gate of the material unloading assembly of the shipping container of FIG. 47.

[0111] FIG. 76 is an enlarged side view of the gate of the material unloading assembly of the shipping container of FIG. 47.

[0112] FIG. 77 is an enlarged fragmentary perspective view of the central portion of the pallet and a part of the bottom compartment of the shipping container of FIG. 47, and illustrating the locking pin and the handle of the gate of the material unloading assembly in an open position.

[0113] FIG. 78 is an enlarged fragmentary front perspective view of the central portion of the pallet and a part of the bottom compartment of the shipping container of FIG. 47, and illustrating the locking pin of the handle of the gate of the material unloading assembly.

[0114] FIG. 79 is an enlarged fragmentary rear perspective view of the central portion of the pallet and a part of the bottom compartment of the shipping container of FIG. 47, and illustrating the locking pin of the handle of the gate of the material unloading assembly.

[0115] FIG. 80 is an enlarged fragmentary exploded perspective view of the corner wall construction of one of the corners of the bottom compartment of the shipping container of FIG. 47, and illustrating the sections of the corner before being attached.

[0116] FIG. 81 is an enlarged fragmentary perspective view of the corner wall construction of one of the corners of the bottom compartment of the shipping container of FIG. 47, and illustrating sections of the corner after being attached.

[0117] FIG. 82 is an enlarged fragmentary top view of the corner wall construction of one of the corners of the bottom compartment of the shipping container of FIG. 47, and illustrating the sections of the corner after being attached.

[0118] FIG. 83 is an enlarged fragmentary perspective view of part of one of the top compartment support assemblies of the shipping container of FIG. 47, and illustrating the locking pin of the assembly inserted in the pin receipt in a corner of the bottom compartment.

[0119] FIG. 84 is an enlarged perspective view of one of the combined support bracket and pin holders of one of the top compartment support assemblies of the shipping container of FIG. 47, shown removed from the top compartment of the container.

[0120] FIG. 85 is an enlarged fragmentary partially cut away side view of one of the locking pins of one of the top compartment support assemblies inserted in a pin receipt of one of the corners of the bottom compartment of the shipping container of FIG. 47, and illustrating the locking pin in a locked position and supporting the corner of the top compartment.

[0121] FIG. 86 is an enlarged fragmentary side view of one of the locking pins of one of the top compartment support assemblies inserted in a pin receipt of one of the corners of the bottom compartment of the shipping container

of FIG. 47, and illustrating the locking pin in a locked position and supporting the corner of the top compartment.

[0122] FIG. 87 is a perspective view of the top compartment of the shipping container of FIG. 47, shown removed from the bottom compartment and with a sleeve attached to the interior surfaces of the top compartment.

[0123] FIG. 88 is an enlarged perspective view of one of the nesting or stacking guides of the shipping container of FIG. 47, shown removed from the top compartment.

[0124] FIG. 89 is an enlarged fragmentary perspective view of one of the corners of the top compartment of the shipping container of FIG. 47, and illustrating the nesting or stacking guide and the nesting supports attached at that corner.

[0125] FIG. 90 is an enlarged fragmentary side view of a portion of the top compartment of a first shipping container of FIG. 47 and a portion of the pallet and bottom compartment of a second shipping container of FIG. 47, where the portion of the pallet is shown stacked on the top compartment of the first shipping container.

[0126] FIG. 91 is a further enlarged fragmentary perspective view of the top compartment of a first shipping container of FIG. 47 and a portion of the pallet of a second shipping container of FIG. 47, where the portion of the pallet is shown stacked on the top compartment of the first shipping container.

[0127] FIG. 92 is an enlarged fragmentary side perspective view of a corner of the bottom compartment of the shipping container of FIG. 47 resting on a corner of pallet of the shipping container of FIG. 47, where the top compartment of the shipping container is in the retracted or collapsed position and the shipping container is empty.

[0128] FIG. 93 is an enlarged fragmentary side perspective view of a corner of the bottom compartment of the first shipping container of FIG. 47 resting on a corner of pallet of the shipping container of FIG. 47, where the top 19 compartment of the shipping container is in the retracted or collapsed position and the shipping container is empty.

[0129] FIG. 94 is an enlarged fragmentary side perspective view of a corner and side wall of the bottom compartment, a corner and side wall of the top compartment, and a side wall of the top compartment of the shipping container of FIG. 47, where the shipping container is full, and the side walls are bowed outwardly.

[0130] FIG. 95A is a fragmentary cross section view of two of the side walls and the corner between those side walls of the bottom compartment, and two of the side walls and the corner between those side walls of the top compartment of the shipping container of FIG. 47, where the shipping container is empty.

[0131] FIG. 95B is a fragmentary cross section view of two of the side walls and the corner between those side walls of the bottom compartment, and two of the side walls and the corner between those side walls of the top compartment of the shipping container of FIG. 47, where the shipping container is full and the side walls are bowed outwardly.

[0132] FIG. 96A is an enlarged fragmentary cross section view of two of the side walls and the corner between those side walls of the bottom compartment, and two of the side walls and the corner between those side walls of the top compartment of the shipping container of FIG. 47, where the shipping container is empty.

[0133] FIG. 96B is an enlarged fragmentary cross section view of two of the side walls and the corner between those

side walls of the bottom compartment, and two of the side walls and the corner between those side walls of the top compartment of the shipping container of FIG. 47, where the shipping container is full and the side walls are bowed outwardly.

[0134] FIG. 97 is a fragmentary perspective view of another example embodiment of the shipping container of the present disclosure.

DETAILED DESCRIPTION OF EXEMPLARY EMBODIMENTS

[0135] Referring now to the drawings, FIGS. 1 to 40 illustrate one example embodiment of the bulk material shipping container of the present disclosure. This shipping container, which is generally indicated by numeral 50, has an expanded position for holding materials during shipping and a retracted position for efficient shipping when the container is not holding materials or when the container is holding a smaller amount of materials. More specifically, FIG. 2 illustrates the shipping container 50 in the retracted position, and FIGS. 1, 3, 4, 5, 34 illustrate the shipping container 50 in the expanded position. It should thus be appreciated that in the retracted position (as shown in FIG. 2), the shipping container 50 can be used for efficient transport as further described below, and that this provides substantial savings in shipping cost and energy use.

[0136] Generally, as shown in FIGS. 1 to 9B, this illustrated embodiment of the shipping container 50 includes: (a) a pallet 100 (as partially shown in FIGS. 1, 2, 3, 4, 5, 7, 8, 9, and 9F, and as best shown in FIGS. 10, 10A, 11, 12, 13, 14, 15, 16, 17, 17A, 18, 18A, 19, 19A, 24, 25, and 26) configured for supporting the container 50 and to facilitate movement and of the container 50 as well as the stacking of multiple containers; (b) a bottom compartment 200 (as best shown in FIGS. 1, 2, 3, 4, 5, 8, 9, 9A, 9B, 9C, 9D, 9E, 9F, and 34) mounted on the pallet 100 and configured to hold materials; (c) a top compartment 300 (as best shown in FIGS. 1, 2, 3, 4, 5, 6, 8, and 34) mounted on the bottom compartment 200 and configured to hold materials; (d) a plurality of top compartment support assemblies 400 (as partially shown in FIGS. 1, 2, 3, 4, 5, and 8, and as best shown in FIGS. 28, 29, 30, 31, and 32) configured to support the top compartment in the expanded position relative to the bottom compartment and configured to release the top compartment from the expanded position to enable the top compartment to move downwardly into the retracted position; (e) a material unloading assembly 500 (as partially shown in FIGS. 3, 4, 7, 8, 9E, and 9F and as best shown in FIGS. 9C, 9D, 10, 10A, 11, 12, 14, 15, 16, 17, 17A, 18, 18A, 19, 19A, 20, 21, 22, 23, 24, 25, and 26) attached to the bottom compartment and supported by the pallet 100 and configured to facilitate the unloading of materials from the top and bottom compartments; (f) a material loading assembly 600 (as partially shown in FIGS. 1, 2, 4, 5, 6, and 8, and as best shown in FIGS. 34, 35, 36, and 37) mounted on the top compartment and configured to facilitate the loading of material into the top and the bottom compartments; and (g) a top compartment extension assembly 700 (as best shown in FIGS. 1, 2, 4, 5, 6, 8, 33, and 34) attached to the top compartment 300 and configured to enable a user to move the top compartment from the retracted position to the expanded position. It should also be appreciated that generally the container includes a front side or face, a back side

or face opposite the front side, a right side or face, and a left side or face as further discussed below.

[0137] In this illustrated embodiment, (a) the pallet 100 is approximately 56 inches (142.24 centimeters) by approximately 44 inches (111.76 centimeters) by approximately 6 inches (15.24 centimeters); (b) the bottom compartment 200 is approximately 56 inches (142.24 centimeters) by approximately 44 inches (111.76 centimeters) by approximately 27 inches (68.58 centimeters); and (c) the top compartment 300 is approximately 56 inches (142.24 centimeters) by approximately 44 inches (111.76 centimeters) by approximately 27 inches (68.58 centimeters). When the container is in the retracted position, the container is approximately 56 inches (142.24 centimeters) by approximately 44 inches (111.76 centimeters) by approximately 35 inches (88.90 centimeters). When the container is in the expanded position, the container is approximately 56 inches (142.24 centimeters) by approximately 44 inches (111.76 centimeters) by approximately 62 inches (157.48 centimeters). However, it should be appreciated that the container and the components thereof may be other suitable sizes.

[0138] This embodiment of the shipping container of the present disclosure is configured to directly hold materials or to receive and hold a large plastic bag which holds the materials in the interior areas defined by bottom and top compartments. In one embodiment, the bag: (a) is approximately 60 inches (15.40 centimeters) by approximately 55 inches (139.70 centimeters) by approximately 110 inches (279.40 centimeters); (b) has a flat bottom with no bottom seal and hermetic side seals; (c) is FDA compliant; (d) has an approximately 2 millimeter thickness; (e) is clear; and (f) is made from a low density recyclable polyethylene plastic. In one alternative embodiment, the bag is also or alternatively bio-degradable. It should be appreciated that each of the bags is thus suited to hold one load of materials. However, it should be appreciated that the plastic bag may be of any suitable size, configuration, and material, provided that it fits inside of the top and bottom compartments of the container and that the bottom of the bag is able to be readily opened for unloading of the materials. It should be appreciated that the bag will be appropriately folded so that when the bag is placed above and partially in the container for filling the bag (and the container) with the materials, that the bag will properly unfold and be suitably seated in the top and bottom compartments of the container. The filling and un-filling of the bag is further discussed below.

[0139] More specifically, as best shown in FIGS. 1, 2, 3, 4, 5, 8, 9, 9A, 9B, 9C, 9D, 9E, and 9F, the bottom compartment 200 includes: (a) a lower exterior bottom wall or panel 202 defining a material release opening or chute 204; (b) an upper interior bottom wall 210 defined by four attached downwardly angled sections or chute ramps 212, 214, 216, and 218; (c) four wedge shaped interior bottom wall supports or gussets 222, 224, 226, and 228; (d) spaced apart first and second or front and back exterior walls 232 and 236; and (e) spaced apart third and fourth or left and right exterior side walls 234 and 238. The four sections 212, 214, 216, and 218 of the upper interior bottom wall 210, the front and back exterior walls 232 and 236, and the exterior side walls 234 and 238 define a bottom compartment material holding area or cavity which extends downwardly toward and to the material release opening or chute 204. In this illustrated embodiment, the lower exterior bottom wall 202, the upper interior bottom wall 210, the interior bottom

wall supports **222**, **224**, **226**, and **228**, the front and back exterior walls **232** and **236**, and the exterior side walls **234** and **238** are all made of stainless steel or galvanized steel to: (a) facilitate attachment or connection of these parts by welding and/or suitable fasteners; (b) provide structural strength and rigidity; (c) facilitate ease of cleaning; (d) facilitate ease of repair; (e) prevent rusting; (f) minimize overall weight of the container; and (g) prevent contamination. However, it should be appreciated that in alternative embodiments, one or more of these components can be made from other suitable materials and that these components can be attached or connected in other suitable manners. The exterior bottom wall **202** of the bottom compartment **200** is suitably attached to the pallet **100** of the container **50** by suitable fasteners; however, it should be appreciated that the exterior bottom wall can be attached in other suitable manners.

[0140] More specifically, the lower exterior bottom wall **202** includes: (a) a rectangular substantially flat base **206** which defines the centrally located rectangular material release opening or chute **204**; and (b) an upwardly extending lip **208** extending upwardly from each of outer edges of the base **206**. This material release opening or chute **204** enables materials in the top and bottom compartments (or in a bag therein) to flow out of bottom compartment **200** when the chute door or gate **510** of the material unloading assembly for the opening or chute **204** (and the bag therein) is opened as further discussed below. The opening **204** in this illustrated embodiment is approximately 8 inches (20.32 centimeters) by approximately 11 inches (27.94 centimeters), although it should be appreciated that the opening may be of other suitable sizes. This size of the opening relative to the size of the bottom and top compartments maximizes the rate of unloading of the material from the top and bottom compartments (or in a bag therein) without sacrificing structure or strength of the bottom compartment.

[0141] The interior bottom wall supports **222**, **224**, **226**, and **228** are attached in spaced apart locations to the top of the base **206** by fasteners, although they can also or alternatively be attached by welding. Each of the interior bottom wall supports or gussets **222**, **224**, **226**, and **228** are of a wedge shape such that they are configured to be engaged by and support a respective one of the downwardly angled sections **212**, **214**, **216**, and **218** of the upper interior bottom wall **210**. The gusset **222** is wider than the other gussets **224**, **226**, and **228** in this illustrated embodiment to distribute the weight of the materials supported by gusset **222** to the pallet **100** at further spaced apart locations which are not directly over the gate **510** of the material unloading assembly **500** (which is further described below). The upper interior bottom wall **210**, and specifically the four downwardly angled sections **212**, **214**, **216**, and **218** are respectively attached to the interior bottom wall supports or gussets **222**, **224**, **226**, and **228** by welding, although they can also or alternatively be attached by fasteners. The interior bottom wall supports or gussets **222** and **226** are somewhat shorter (as best seen in FIGS. **8**, **9**, **9E**, **9F**, **17**, **17A**, **18**, **18A**, **19**, and **19A**) than the interior bottom wall supports or gussets **224** and **228** to prevent too much weight from being placed on the material unloading assembly **500** and particularly on the gate **510**. The four downwardly angled sections **212**, **214**, **216**, and **218** each have a lower edge such that when such sections are attached, such sections form an opening **211** adjacent to and substantially aligned with the opening **204** of the base wall

206. In particular, the lower edges of the four downwardly angled sections **212**, **214**, **216**, and **218** extend downwardly approximately adjacent to the material release opening or chute **204** of the base **206** of the bottom compartment. The lower edges of one or more of these four downwardly angled sections are each configured to be supported by the pallet adjacent to the top shelf of the pallet. In other words, this construction enables the central area of the pallet to provide support for part of the weight of the materials held in the top and bottom compartments. The upper interior bottom wall **210**, and specifically upper portions of the four downwardly angled sections **212**, **214**, **216**, and **218** are also respectively attached to and supported by the exterior walls **232**, **234**, **236**, and **238**. It should thus be appreciated that the upper interior bottom wall **210** of the bottom compartment **200** is supported at multiple locations including multiple points of support by the various different portions of the pallet **100**. More specifically, the sections **212**, **214**, **216**, and **218** of the upper interior bottom wall **210** are supported: (a) at their top ends by the exterior walls **232**, **234**, **236**, and **238** of the bottom compartment **200**; (b) centrally by interior bottom wall supports or gussets **222**, **224**, **226**, and **228**; (c) by attachment to each other; and (d) by the central portion of the pallet **100**.

[0142] The exterior walls **232**, **234**, **236**, and **238** of the bottom compartment **200** also each includes a skirt that extends downwardly along a respective side of the pallet **100**. Suitable fasteners such as screws are used to attach each skirt to the respective side of the pallet **100** to support these exterior walls. Thus, it should be appreciated that this attachment to the side walls of the pallet **100** provides another set of support points for the bottom compartment **200**. It should thus be appreciated that the upper interior bottom wall **210** is suitably angled and supported to hold the materials without deforming and to facilitate unloading of the bulk material from the material holding area of the bottom compartment.

[0143] Each of the exterior walls **232**, **234**, **236**, and **238** of the bottom compartment **210** include a rectangular panel and two L-shaped corner sections attached to opposite ends of the panel. Each L-shaped corner section of each panel of each exterior wall is configured to mate with the L-shaped corner of an adjacent exterior wall as generally shown in FIGS. **27A**, **27B**, and **27C**. These L-shaped corner sections of each of the exterior side wall: (a) are preferably connected by welding; (b) add structural rigidity to the bottom compartment; and (c) in conjunction with the top compartment support assemblies **400** provide support the support of the top compartment in the expanded position as further described below. More specifically, as illustrated in FIGS. **27A**, **27B**, and **27C**, exterior side wall **232** includes panel **252** and corner **262** which includes corner sections **262a** and **262b**, and exterior side wall **234** includes panel **254** and corner **264** which includes corner sections **264a** and **264b**. Corner sections **264a** is mated with and attached to corner section **262a**, and corner section **264b** is mated with and attached to corner section **262b** to form this corner of the bottom compartment **200**. It should be appreciated that each corner of the bottom compartment is configured in a similar manner; however, it should be appreciated that one or more of the corners can be differently configured. In this illustrated embodiment, each of the exterior walls **232**, **234**, **236**, and **238** of the bottom compartment **210** also includes a top edge which is curled or bent over to provide extra strength

to the bottom compartment and to minimize interference with movement of the top compartment 300 relative to the bottom compartment 200.

[0144] The top compartment 300 of the container 50, as best shown in FIGS. 1, 2, 3, 4, 5, 6, 8, 34, and 35, includes an exterior top wall 302, spaced apart exterior front and back side walls 312 and 316, spaced apart exterior side walls 316 and 318, and exterior wall support brackets 322, 324, 326, and 328 respectively attached to the exterior side walls 312, 314, 316, and 318. In this illustrated embodiment, the exterior top wall 302, exterior side walls 312, 314, 316, and 318, and exterior wall support brackets 322, 324, 326, and 328 are also all made of stainless steel or galvanized steel to: (a) facilitate attachment or connection of these parts by welding and/or suitable fasteners; (b) provide structural strength and rigidity; (c) facilitate ease of cleaning; (d) facilitate ease of repair; (e) prevent rusting; (f) minimize overall weight of the container; and (g) prevent contamination. However, it should be appreciated that in alternative embodiments, one or more of these components can be made from other suitable materials and attached or connected in any suitable manner. The upper interior base wall 306 and the exterior walls 312, 314, 316, and 318 define a top compartment material holding area or cavity which extends downwardly to the bottom compartment material holding area or cavity.

[0145] The exterior top wall 302 includes a rectangular substantially flat base 306 which defines the centrally located rectangular material receipt or loading opening or chute 304. This material receipt or loading opening or chute 304 enables materials to flow into the top and bottom compartments when the cover of the material loading assembly is opened as further discussed below. The opening 304 in this illustrated embodiment is 18 inches (45.72 centimeters) by 18 inches (45.72 centimeters), although it should be appreciated that the opening may be of other suitable sizes. This size opening relative to this size bottom and top compartments maximizes the rate of loading of the material into the top and bottom compartments without sacrificing structure or strength of the top compartment 300.

[0146] The upper interior base wall 306 is suitably attached to the upper portions of the exterior walls 312, 314, 316, and 318 by welding. The exterior wall support brackets 322, 324, 326, and 328 are respectively attached to the exterior side walls 312, 314, 316, and 318 by welding, although they can be attached by rivets or other suitable fasteners. It should be appreciated that for embodiments of the container which will employ a bag, it is preferable to maximize the amount of welding for connecting or attaching components to reduce possible spots or points for snagging or cutting the bag. It should also be appreciated that for a container that will not employ a bag, more rivets or other fasteners can be employed. Similar to the configuration of the bottom compartment, each of the exterior walls 312, 314, 316, and 318 include a rectangular panel and two L-shaped corner sections attached to opposite ends of the panel. Each L-shaped corner section of each panel of each exterior wall is configured to mate with the L-shaped corner of the adjacent exterior wall similar to the bottom compartment. These L-shaped corner sections of each of the exterior side wall of the top compartment are preferably connected by welding and add structural rigidity to the top compartment.

[0147] It should be appreciated that in alternative embodiments, the top compartment can include one or more interior

walls. These interior walls in certain embodiment are used to protect the exterior walls, and to add further structural rigidity to the top compartment.

[0148] The pallet 100 of this illustrated embodiment of the shipping container 50 of the present disclosure is specifically configured to take in account that various different lifting and moving vehicles or equipment may be used to lift and move the container 50: (a) when the container is manufactured; (b) when the container is transported to a material loading facility; (c) when the container is at a material loading facility; (d) when the container is moved and positioned in a transport vehicle at the material loading facility after loading materials in the container; (e) when the container is removed from a transport vehicle at a material unloading facility; (f) when the container is at an unloading facility; and (g) when the container is moved and positioned in a transport vehicle at the material unloading facility after unloading the materials from the container. More specifically, these facilities will typically have either a conventional pallet jack and/or a conventional fork lift. One widely commercially used conventional pallet jack has spaced apart non-movable tines or forks, where each fork is approximately 7.75 inches (19.69 centimeters) wide and the space between the tines is approximately 8.50 inches (21.59 centimeters). One widely commercially used conventional fork lift has adjustably spaced apart tines or forks, where each fork is approximately 5 inches (12.70 centimeters) wide, and the space between that tines is adjustable from approximately 4 inches (10.16 centimeters) to approximately 24 inches (60.96 centimeters). As further described below, the container 50 and specifically the pallet 100 of the container 50 is configured to account for the use of such fork lifts which can: (a) lift the containers off of the ground; (b) move the containers; (c) stack the containers on top of each other; and (d) un-stack stacked containers from each other. As also further described below, the container 50 and specifically the pallet 100 of the container 50 is also configured to account for the use of such pallet jacks which can: (a) lift the containers off of the ground; and (b) move the containers, but can not stack or unstack stacked containers.

[0149] More specifically, turning now to FIGS. 1, 3, 4, 5, 7, 8, 10, 10A, 11, 12, and 13, the pallet 100 of this illustrated embodiment of the container 50 of the present disclosure includes: (a) a rectangular body 102 having an upper surface 104, a lower surface 106, a front edge 112, a back edge 116, and opposite side edges 114 and 118; and (b) a plurality of legs 122, 124, 126, and 128 extending downwardly from the body 102. The legs 122 and 126 each respectively extend the entire width of the body 102 of the pallet 100 in this illustrated embodiment. It should be appreciated that in alternative embodiments the legs 122 and 126 do not need to extend the entire width of the body and that each of these legs can be separated into multiple legs. The legs or islands 124 and 128 extend downwardly from the central portions of the side ends of the body 102. In this illustrated embodiment, the body and the legs of the pallet are all formed from one piece of a suitable wood to: (a) provide structural strength and rigidity; and (b) minimize overall weight of the container. In this illustrated embodiment, the wood pallet is one piece of wood which is suitably formed by suitable cutting, milling and/or routing processes. However, it should be appreciated that in alternative embodiments, the pallet can be made from multiple components which are suitably attached and that one or more of these components can be

made from other suitably strong materials such as composite or fiber glass materials. It should also be appreciated that different parts of the pallet may be made from different materials. For instance, the shelves may be made from a plastic, composite or fiber glass inlay part.

[0150] The pallet **100** includes or defines: (a) a first set of aligned fork lift tine receiving channels **132a** and **136a** in the legs **122** and **126**, respectively; (b) a second set of aligned fork lift tine receiving channels **132b** and **136b** in the legs **122** and **126**, respectively; (c) a first pallet jack tine receiving channel **140** extending from side to side; and (d) a second pallet jack tine receiving channel **142** extending from side to side. The first set of fork lift tine receiving channels **132a** and **136a** and the second set of fork lift tine receiving channels **132b** and **136b** are positioned and spaced apart such that when the forks or tines of a fork lift are inserted into these channels of the pallet **100** of the container **50** which is stacked on top of another container, the tines or forks do not engage the material loading assembly on the top compartment of the lower container or the extension assembly on the top compartment of the lower container. It should thus be appreciated that the pallet **100** is configured to enable a fork lift to move these containers when one container is stacked on another container without damaging the lower container, and particularly the cover or the extension assembly. The first pallet jack tine receiving channel **140** and the second pallet jack tine receiving channel **142** are positioned and spaced apart such that when the forks or tines of a pallet jack are inserted into these channels defined by the pallet **100** of the container **50**, they can lift and move the container. It should be appreciated that a typical pallet jack does not operate like a fork lift so that the pallet jack will only be used when the container is on the floor or ground and not with stacked containers. Therefore, the tines or forks of a pallet jack will not be in a position to engage the material loading assembly on the top compartment of the lower container of stacked containers or the extension assembly on the top compartment of the lower container of stacked containers.

[0151] It should be appreciated that the first set of aligned fork lift tine receiving channels **132a** and **136a** and the second set of aligned fork lift tine receiving channels **132b** and **136b** are not configured to receive the forks or tines of a pallet jack because they are spaced apart further than the tines on a conventional pallet jack (as described above). Specifically, they are spaced apart approximately 34 inches (86.36 centimeters) in this illustrated embodiment.

[0152] It should further be appreciated that although not preferred, a fork lift with adjustable forks or tines can be inserted into the first pallet jack tine receiving channels **140** and **142** to lift and move the container **50**. The pallet **50** and the channels **140** and **142** are also configured to take this into account, and specifically to account for this situation when the forks or tines of a fork lift are inserted into these channels **140** and **142** of the pallet **100** of a container stacked on another container, these tines or forks do not engage the material loading assembly on the top compartment of the lower container or the extension assembly on the top compartment of the lower container.

[0153] It should further be appreciated that in this illustrated embodiment, the legs **124** and **128** of the pallet **100** are also configured to direct the tines or forks of the pallet jack through the channels **140** and **142** if they are inserted at an angle with respect to these channels. Specifically, leg **124** includes four angled tine directing surfaces **154a**, **154b**,

154c, and **154d**, and leg **128** includes four angled tine directing surfaces **158a**, **158b**, **158c**, and **158d**. It should further be appreciated that the legs **124** and **128** do not block the fork lift tine receiving channels **132a** and **136a** or the fork lift tine receiving channels **132b** and **136b**.

[0154] It should further be appreciated, that although not shown, the pallet can include indicator which direct a user on how to insert the tines of a fork lift into the pallet jack receiving channels **140** and **142**. It should also be appreciated, that although not shown, the pallet can include hinged or pivoting flaps in the ends of the pallet jack receiving channels **140** and **142** to further direct a user on how to insert the tines of a fork lift into the pallet jack receiving channels **140** and **142**.

[0155] It should also be appreciated that the shape of the legs of the pallet, which rest on the ground, and particularly the flat surfaces of the pallet, prevent the build-up of contaminants on the pallet. Specifically, in the illustrated embodiment, the bottom of the pallet does not include a series of cavities in which contaminants such as mud or dirt can build up. Therefore, the pallet provides a less contaminable bulk material container while still being relatively strong and light weight.

[0156] Turning now to FIGS. **3**, **4**, **7**, **8**, **10**, **10A**, **11**, **12**, and **13**, as mentioned above, the body **102** of the pallet **100** also functions: (a) to support the upper interior bottom wall of the bottom compartment **200**; and (b) to support the material unloading assembly **500**. More specifically, the body **102** of the pallet **100** defines multi-level shelves including a first or bottom shelf **150** and a second or top shelf **160**, and an opening or chute **170**.

[0157] The first or bottom shelf **150** includes front shoulder **152**, left side shoulder **154**, and right side shoulder **158**. These shoulders **152**, **154**, and **158** are sized and configured to support a bottom portion of each of the guide rails and the door or gate of the material unloading assembly which is further described below. The door or gate includes a closure member or portion and the handle member or portion (as further discussed below). The shoulders **152**, **154**, **32** and **158** support the guide rails (attached to the bottom compartment as described below) which in turn support the side edges of the closure member as well as the handle portion of the chute door or gate of the material unloading assembly. The shoulders **152**, **154**, and **158** are positioned at the same level to co-act to support the chute door or gate of the material unloading assembly such that the chute door or gate moves or slides relative to the bottom shelf **150** from a closed position to an open position for respectively closing and opening the chute **202** in the exterior bottom wall of the bottom compartment **100** as well as the opening or chute **170** in the pallet **100** as further discussed below.

[0158] The second or top shelf of the pallet **100** includes left side shoulder **164**, rear shoulder **166**, and right side shoulder **168** which are configured at the same level to co-act to also support a top portion of each of the guide rails and the door or gate of the material unloading assembly which is further described below. It should also be appreciated that this configuration enables the pallet to support the bottom compartment and the material unloading assembly and specifically the chute door or gate. This support reduces the amount of weight placed on the gate from the materials held in the top and bottom compartments (or the bag therein).

[0159] In the illustrated embodiment, and as particularly illustrated in FIGS. 9C and 9D, the container 50 and in particular the material unloading assembly 500 includes a plurality of guide rails 163, 165, 167, 169, and 171. Guide rail 163 is secured to the exterior bottom wall 206 and is configured and positioned to be supported by the front portions of shoulders 154 and 164. Guide rail 165 is secured to the exterior bottom wall 206 and is configured and positioned to be supported by the central and rear portions of the shoulders 154 and 164. Guide rail 167 is secured to the exterior bottom wall 206 and is configured and positioned to be supported by the rear shoulders 156 and 166. Guide rail 169 is secured to the exterior bottom wall 206 and is configured and positioned to be supported by the central and rear portions of shoulders 158 and 168. Guide rail 171 is secured to the exterior bottom wall 206 and is configured and positioned to be supported by the front portions of the shoulders 158 and 168. It should be appreciated that FIGS. 10A, 14, 15, and 16 illustrate these guide rails 163, 165, 167, 169, and 171 detached from or without the exterior bottom wall 206 and in the positions where they rest on and are supported by these shoulders of the pallet 100. It should also be appreciated that these guide rails function in multiple ways. The guide rails 163, 165, 167, 169, and 171 support and guide the movement of closure portion and the handle portion of the chute door or gate 510 of the material unloading assembly 500. The gate slides or moves on or above these guide rails 163, 165, 167, 169, and 171, and these guide rails prevent the downward movement of the chute door or gate and also prevent loose materials being held in the top and bottom compartments from accumulating on or adjacent to the chute door or gate or the shoulders. The guide rails 165, 167, and 169 also rest on the shoulders to provide additional support for the bottom compartment.

[0160] The body 102 of the pallet 100 also includes defines a handle chamber 180 and a stopping wall 182 for the handle of the material unloading assembly (as described below). The handle chamber 180 and the stopping wall 182 of the pallet 100 are further discussed below in conjunction with the discussion of the material unloading assembly 500.

[0161] Turning now to FIGS. 3, 4, 7, 9C, 9D, 9E, 9F, 14, 15, 16, 17, 17A, 18, 18A, 19, 19A, 20A, 20B, 20C, 20D, 21, 22, 23, 24, 25, and 26, the material unloading assembly 500 of the container 50 is supported by both bottom wall 206 of the bottom compartment 200 and the body 102 of the pallet 100 under and adjacent to the opening or chute 204 in the bottom compartment 200 and above the opening or chute 170 in the pallet 100. The material unloading assembly 500 includes a chute door or gate 510 slidably positioned on the guide rails 163, 165, 167, 169, and 171, and partially supported by the shoulders 152, 154, and 158 defined by the body 102 of the pallet 100 as discussed above. The gate 510 includes a handle member or portion 512 and a closure member or portion 516 extending from the handle member or portion 512. The gate 510 is movable or slidable from a closed position as shown in FIGS. 9C, 9D, 9E, 9F, 14, 17, and 17A to a plurality of different partially open positions (such as the partially open position shown in FIGS. 15, 18 and 18A), and then to a fully open position shown in FIGS. 16, 19, and 19A. It should also be appreciated that the body 102 of the pallet 100 defines a plurality of stopping walls that prevent the gate 510 from moving too far outwardly and also keeps the handle portion 512 of the gate 510 relatively close to the pallet 100. In this embodiment, the gate and the

guide rails are made of stainless steel or galvanized steel to: (a) provide structural strength and rigidity; (b) facilitate ease of cleaning; (c) facilitate ease of repair; (d) prevent rusting; (e) minimize overall weight of the container; and (f) prevent contamination. However, it should be appreciated that in alternative embodiments, the gate and the guide rails can be made from other suitable materials.

[0162] The material unloading assembly 500 further includes a knife 520 attached to the bottom surface of the gate 510. Specifically, the knife 520 includes a biasing member in the form of a leaf spring 522 having an attachment end 524 attached to the bottom surface of the gate 510 and a fin shaped blade 530 attached to the top side of the opposite or free end 526 of leaf spring 522. As best shown in FIGS. 17A, 18A, 19A, 21, 22, and 23, the fin shaped blade 530 includes: (a) an attachment base 532 attached to the top of the free end 526 of the leaf spring 522; and (b) a cutting member 534 attached to and extending from the attachment base 532. The cutting member 534 includes an accurate shaped cutting edge 536 and back edge 538 opposite the cutting edge 536. The leaf spring 522 biases the blade 530 upwardly such that the blade 530 is biased upwardly and the cutting member 534 and extends through a vertically extending slot 518 (see FIGS. 20A and 20B) in the closure portion 516 of the gate 510 toward a fully expanded position. In this illustrated embodiment, the knife is made of stainless steel or galvanized steel to: (a) facilitate attachment or connection of these parts by welding and/or suitable fasteners; (b) facilitate ease of cleaning; (c) facilitate ease of repair; (d) prevent rusting; (e) minimize overall weight of the container; and (f) prevent contamination. However, it should be appreciated that in alternative embodiments, the knife can be made from other suitable materials. In this illustrated embodiment, the leaf spring is made of stainless steel or galvanized steel; however, it should be appreciated that in alternative embodiments, the leaf spring can be made from other suitable materials and in other configurations.

[0163] The knife 520 (including the leaf spring 522 and the blade 530) moves as the gate 510 moves, and specifically is configured to move from a retracted position as shown in FIGS. 14, 17, 17A, and 20D to a plurality of different extended positions such as the partially extended position shown in FIGS. 15, 18, and 18A and to a fully extended position shown in FIGS. 16, 19, and 19A. The gate 510 is configured to be opened by an unloader such that pulling the handle portion 512 of the gate (and particularly the handle 513) from the closed position to an open position, causes the blade 530 of the cutting member 534 of the knife 520 to extend through the slot 518 and to engage the bottom of the bag (not shown) in the container 50 which holds the material, and to cut a hole in the bottom of the bag to release the material in the bag.

[0164] When the gate 510 is in the fully closed position, the cutting member 534 of the blade 530 rests below the guide rail 167 as shown in FIGS. 9C, 9D, 17, and 17A. When the gate 510 is in the fully open position, the cutting member 534 of the blade 530 is adjacent to the front section 212 of the interior bottom wall 210 as shown in FIGS. 19 and 19A. It should further be appreciated that as the gate 510 is moved from the fully open position to the closed position, the knife 520 (including the leaf spring 522 and the blade 530) moves with the gate 510 from the fully extended position to a partially retracted position to a fully retracted position. More specifically, the back edge 538 of the cutting

member **534** is configured such that when the back edge **538** of the cutting member **534** contacts the bottom of the guide rail **167**, the entire blade **520** and the free end **526** of the leaf spring **522** is forced downwardly against the upward bias of the leaf spring **522** and back into the retracted position as shown in FIGS. 9C, 9D, 17, and 17A. It should also be appreciated that the knife **520** does not interfere with the opening of the gate in the embodiments where a bag is not employed to hold the materials in the container.

[0165] The material unloading assembly **500** also includes a locking assembly **550** configured to enable a user to lock the gate **510**, and specifically the handle portion **512** of the gate **510** to the stopping wall **182** of the pallet **510** to prevent the handle portion **512** and the gate **510** from being accidentally opened at undesired points in time such as: (a) during loading of the container **50**; (b) during transit of the container **50**; or (c) at any other point in time prior to an unloader opening the gate **510**. More specifically, as best seen in FIGS. 10A, 11, 12, 14, 15, 16, 17, 18, 20A, 20B, 20C, 20D, 24, 25, and 26, the handle portion **512** of the gate **510** includes a downwardly extending handle **513** which is configured to be gripped by a user to open and close the gate **510**. The downwardly extending handle **513** defines a centrally located opening **514** (as best shown in FIG. 20A). The material unloading assembly **500** also includes a stopping plate **560** attached to the outside surface of the stopping wall **182**. The stopping plate **560** includes an opening **561** aligned with the centrally located opening **514** of the handle **513** of the handle portion **512** of the gate **510**. The stopping wall **182** also includes a hole which is larger than the hole **561** in the stopping plate **560** and is configured to receive a locking pin **590**. More specifically, the material unloading assembly **500** further includes a locking pin **590** configured to be inserted through: (a) the centrally located opening **514** of the handle **513** of the handle portion **512** of the gate **510**; (b) the opening **561** in the stopping plate **560**; and (c) an opening **183** in the stopping wall **182**, when the gate **510** is in the closed position. This locking pin **590** engages the rear surface of the stopping plate **560** to prevent unwanted opening of the gate **510**. When the user desires to open the gate **510**, the user activates the locking pin **590** and fully or partially removes the locking pin **590** from the stopping wall **182** and the stopping plate **560**. It should be appreciated that as shown in the various figures, the locking pin **590** can be left in the handle **513** of the gate **510**. It should also be appreciated that the locking pin can be placed in a different hole in the handle of the gate **510**. It should further be appreciated, that although not shown, the material unloading assembly can further include one or more guides for holding the locking pin **590** level or otherwise in position for easy re-insertion when the gate **510** is in a fully open or partially open position. It should be appreciated that the locking pin can be commercially obtained from MCMaster-Carr, and that any other suitable locking pin may be employed.

[0166] It should also be appreciated that by pushing the handle back toward the closed position, the chute can be closed or partially closed. It should also be appreciated that placing the handle in a partially open or partially closed positioned enables the user to control the rate of emptying the materials from the container **50**.

[0167] Turning now to FIGS. 1, 2, 3, 4, 5, 8, 28, 29, 30, 31, and 32, the top compartment **300** is supported by a plurality of top compartment supporting assemblies **400a**, **400b**, **400c**, and **400d** which are each configured to support

a different one of the corners of the top compartment **300** and to hold the top compartment **300** in the expanded position. In the illustrated embodiment, each top compartment support assembly **400a**, **400b**, **400c**, and **400d** is identical; however, it should be appreciated that two or more of these support assemblies may be different. Support assembly **400a** is discussed herein as an example.

[0168] Support assembly **400a** includes a support pin **410a** configured to be inserted through a pin receipt or pin receipt hole **450a** (at least shown in FIGS. 8 and 27B) in the corner of the bottom compartment **200** and into a tubular support pin receiver or sleeve **412a** of the support assembly **400a** which is suitably attached (such as by welding) to the inside of the corner of the bottom compartment **200** as best illustrated in FIG. 31. It should be appreciated that the configuration and size of the support pin receiver can vary in accordance with the present disclosure. For example, the support pin receiver can be in the form of a flat plate (not shown) attached to the inside of the corner of the bottom compartment.

[0169] The support assembly **400a** further includes a support pin holder **430a** and a tether **460a** attaching the support pin **420a** to the support pin holder **430a**. It should be appreciated that the support pin holder **430a** and the tether **460a** are employed to prevent the support pin **410a** from being lost and to hold the support pin **410a** out of the way of the bottom compartment **200** when the support pin **410a** is not in use, and that in alternative embodiments, the shipping container of the present disclosure does not employ the support pin holders or the tethers. It should also be appreciated that FIGS. 1, 2, 3, 4, 5, 8, 34, 41, 42, 43, 44, 45, and 46 either have a line representing the tether or that the tether is removed from these figures for ease of illustration.

[0170] More specifically, in the illustrated embodiment, the support pin holder **430a** includes an L-shaped body having a mounting member **432a** attached to the corner of the top compartment **300** and a pin holder **434a** connected to the mounting member **432a**. The pin holder **464a** defines a first hole **436a** for attachment of the one end of the tether **430a** and a second hole **438a** for removably holding the support pin **410a** when the support pin **410a** is not in use. This support pin holder **430a** is made from stainless steel or galvanized steel, and welded to the corner of the top compartment **300**. It should be appreciated that the pin holder **434a** could be made from other suitable materials, could be suitably attached to the top compartment in other suitable manners or locations and could be alternatively configured. In this illustrated embodiment, the pin holder is made of stainless steel or galvanized steel to: (a) facilitate attachment or connection of this part by welding and/or suitable fasteners to the top compartment; (b) provide structural strength and rigidity; (c) facilitate ease of cleaning; (d) facilitate ease of repair; (e) prevent rusting; (f) minimize overall weight of the container; and (g) prevent contamination. However, it should be appreciated that in alternative embodiments, the pin holder can be made from other suitable materials and attached or connected to the top compartment in other suitable manners.

[0171] The tether **460a** includes two end loops **462a** and **464a**. End loop **462a** is attached to the support pin holder **430a** and end loop **464b** is attached to the support pin **410a**. The tether **460a** may be any suitable length and made from any suitable material such as steel or a high strength plastic.

[0172] The support pin **410a** in the illustrated embodiment includes a handle **413a**, a tubular body **414a** attached to the handle **412a**, and a locking mechanism **416a** extending through the handle **413a** and tubular body **414a**. The locking mechanism **416a** includes a release button **418a** in and extending from the handle **413a**, an actuation shaft (not shown) connected to the release button **418a**, and a plurality of locking balls **422a** and **422b** extending transversely from the tubular body **414a** adjacent to the end of the tubular body **414a** opposite the handle **413a**. The locking mechanism **416a** is configured such that the locking balls **422a** and **422b** are normally biased by a spring (not shown) toward the outwardly extending locked position as shown in FIG. 31, and such that when the release button **418a** is pressed, the locking balls **422a** and **422b** are allowed to recede inwardly into the tubular member **414a** and specifically into cavities (not shown) in the actuation shaft **420a** to enable the support pin **410a** to be removed. The locking balls **422a** and **422b** are configured to engage the inner surface of the tubular support pin receiver **412a** of the support assembly **400a** to prevent the support pin **410a** in the locked position from being easily removed or removed without actuation of the locking mechanism **416a** and specifically the release button **418a**. Pins of this type are readily commercially available such as from MCMaster-Carr. It should be appreciated that other suitable support pins may be employed with the container in accordance with the present disclosure.

[0173] The container **50** includes an extension assembly **700** which enables a user or loader to move the top compartment from the retracted position to the expanded position to enable insertion of these support pins as further described below.

[0174] Turning now to FIGS. 1, 4, 5, 6, 8, and 33, the extension assembly **700** of the container **50** includes a first set of aligned fork lift tine receiving loops or lifting brackets **702** and **704** and a second set of aligned forklift tine receiving loops or lifting brackets **706** and **708**. Each of the lift tine receiving loops or lifting brackets **702**, **704**, **706**, and **708** are identical in this illustrated embodiment, but it should be appreciated that these components can be different. FIG. 33 illustrate example fork lift tine receiving loop or lifting bracket **702**, which includes a crossbar **720a**, end bars **722a** and **724a** attached to the opposite ends of the crossbar **720a** and mounting bars **726a** and **728a** respectively attached to the opposite ends of the end bars **722a** and **724a**. In this embodiment, these loops or lifting brackets are made of stainless steel or galvanized steel and the mounting bars are each suitably welded to the top wall **302** of the top compartment **300**. The loops or lifting brackets are suitably aligned to form two slots configured to receive forklift forks or tines. These loops enable a loader operating a fork lift to insert the forks of the forklift through the loops and to lift the top compartment from the retracted position to the expanded position. These aligned slots enable a forklift to lift the top compartment of the container from either the front or back. It should be appreciated that the outside surfaces of the container can include suitable markings to indicate to the loader the appropriate expanded position of the top compartment. As mentioned above, in this illustrated embodiment, these loop are all made of stainless steel or galvanized steel to: (a) facilitate attachment or connection of these parts by welding and/or suitable fasteners; (b) provide structural strength and rigidity; (c) facilitate ease of cleaning; (d)

facilitate ease of repair; (e) prevent rusting; (f) minimize overall weight of the container; and (g) prevent contamination. However, it should be appreciated that in alternative embodiments, one or more of these loops can be made from other suitable materials and that these components can be attached or connected in other suitable manners.

[0175] As further described below, when the operator lifts the top compartment upwardly from the retracted position to the expanded position, the locking assemblies described above can then be employed to support and lock the top compartment in the expanded position and to prevent the top compartment from moving back into the retracted position. More specifically, when a user such as a loader of the shipping container **50** desires to move the top compartment from the retracted position to the expanded position, the user uses a fork lift or other lifting apparatus to engage the extension assembly **700** to lift the top compartment **300** such that the bottom corners of the top compartment **300** are above the pin receipt holes in the four corners of the bottom compartment **200**. The user then sequentially takes each support pin out of the respective pin holder, presses the button on the support pin and inserts the support pin in the respective pin receipt hole. It should be appreciated that this is easily and quickly performed by a single person. Thus, it should be appreciated that: (a) a single loader can move the top compartment into the expanded position by lifting the top compartment (using a fork lift); (b) the single loader can engage the support pins of the top compartment supporting assemblies to lock the top compartment in the expanded position; and (c) that prior to unloading the materials, a single un loader can disengage the support pins from the bottom compartment to un-lock the top compartment from the expanded position and release the top compartment from the expanded position, which enables the top compartment to slowly move to the retracted position as the materials empties from the top and bottom compartments. This also prevents the top compartment from rapidly dropping if the support pins are released when no materials are in the compartments. It should further be appreciated that enabling a single person to perform this operation provide a significant advantage in terms of time and cost over certain prior known bulk material shipping containers.

[0176] Turning now to FIGS. 1, 4, 5, 6, 8, 34, 35, 36, and 37, the material loading assembly **600** is generally attached to the top compartment **300** and generally includes: (a) an upwardly extending lip **602** attached to and extending from the top wall **302** of the top compartment **300**; (b) a cover **610** configured to securely engage the upwardly extending lip **602** and pivotally attached to the top wall **302** of the top compartment **300** by a plurality of hinges **630**, **632**, and **634**; (c) a lock assembly **650** including a first portion **652** attached to the top wall **302** of the top compartment **300** and a second portion or lid latch **654** pivotally attached to the cover **610**; (d) and a gasket (not shown) mounted in the cover **610** to seal out contaminants. The cover **610** defines a channel **612** configured to receive the lip **602**. The gasket is mounted in the channel **612** to facilitate the seal between the cover **610** and the lip **602**. It should be appreciated that although the illustrated lip **602** is shown in sections with spaces there between, additional material is preferably welded to the illustrated sections of the lip **602** to form a continuous lip. The locking assembly **650** includes a suitable lock (not shown) which is used to lock the cover **610** in the closed position, and specifically to lock the second portion or lid

latch **654** attached to the cover to the first portion **652** attached to the top wall **302** of the top compartment **300**. It should be appreciated that any suitable lock may be employed and that alternative configurations for the locking assembly may be employed in accordance with the present disclosure. In this illustrated embodiment, these components (except the gasket and the lock) are all made of stainless steel or galvanized steel to: (a) facilitate attachment or connection of these parts by welding and/or suitable fasteners; (b) provide structural strength and rigidity; (c) facilitate ease of cleaning; (d) facilitate ease of repair; (e) prevent rusting; (f) minimize overall weight of the container; and (g) prevent contamination. However, it should be appreciated that in alternative embodiments, one or more of these components can be made from other suitable materials and that these components can be attached or connected in other suitable manners. It should further be appreciated that the shape of the cover may vary in accordance with the present disclosure.

[0177] Turning now to FIGS. **1**, **3**, **4**, **5**, **6**, **8**, **34**, **38**, **39**, and **40**, the container **50** includes a plurality of nesting or stacking or guides **800a**, **800b**, **800c**, and **800d** which are configured to facilitate secure stacking of the containers of the present disclosure as well as stacking of other known bulk material containers. In the illustrated embodiment, each of the stacking guides **800a**, **800b**, **800c**, and **800d** is identical; however, it should be appreciated that two or more of these stacking guides may be different. As generally shown in FIGS. **39** and **40**, the stacking guides assist in positioning one container of the present disclosure on top of another container of the present disclosure.

[0178] More specifically, stacking guide **800a** is discussed herein as an example stacking guide. As best shown in FIG. **38**, stacking guide **800a** include mounting walls **802a** and **804a** configured to be attached to the corner of the top compartment **300** and guide wall **812a** and **814a** respectively attached to and extend from the mounting walls **802a** and **804a**. In this illustrated embodiment, the guide wall **812a** and **814a** each respectively define bag holding slots **820a** and **822a**. These slots are configured to receive and hold a top section of a bag during the filling process to secure the bag in the desired position as the loader fills the bag and the container with materials to the desired height (as generally illustrated in FIG. **42** and as further described below). In this illustrated embodiment, the stacking guides are all made of stainless steel to: (a) facilitate attachment or connection of these parts to the top compartment by welding and/or suitable fasteners; (b) provide structural strength and rigidity; (c) facilitate ease of cleaning; (d) facilitate ease of repair; (e) prevent rusting; (f) minimize overall weight of the container; and (g) prevent contamination. However, it should be appreciated that in alternative embodiments, one or more of these stacking guides can be made from other suitable materials and that these components can be attached or connected in other suitable manners.

[0179] It should be appreciated that the container **50** and the nesting or stacking guides **800a**, **800b**, **800c**, and **800d** of the container **50** are configured to receive or be stacked with known bulk material containers such as the known bulk material container described in the background section of this document. It should be appreciated that as shown in FIGS. **39** and **40**, the container of the present disclosure is configured such that a fork lift can be employed to place one container on top of another container and to lift one con-

tainer from another container without damaging the material loading assembly attached to the top compartment of the lower container, and without damaging the extension assembly attached to the top compartment of the lower container.

[0180] Turning now to FIG. **41**, the container **50** is illustrated with a bag **850** shown draped over the stacking guides **800a**, **800b**, **800c**, and **800d**. The stacking guides **800a**, **800b**, **800c**, and **800d** act as holders and guides for the bag **850** during the loading process. It should be appreciated that the center of the bag **852** is positioned over the opening in the top compartment and under a loading tube **890**. It should also be appreciated that the cover of the material loading assembly has been removed for ease of illustration.

[0181] Turning now to FIG. **42**, the container **50** is illustrated with a bag **850** shown with each end respectively extending through the stacking guides **800a**, **800b**, **800c**, and **800d**. The stacking guides **800a**, **800b**, **800c**, and **800d** act as holders and guides for the bag **850** during the loading process. Again, in this FIG. **42**, the center of the bag **852** is positioned over the opening in the top compartment and under a loading tube **890**. It should be appreciated that the cover of the material loading assembly has been removed for ease of illustration.

[0182] Turning now to FIGS. **43** and **44**, one example embodiment of a bag holder of the present disclosure is generally illustrated and indicated by numeral **1000**. The bag holder **1000** is configured to hold a supply roll of bags **900** and to sequentially provide each of the bags from the supply roll **900** for positioning over the shipping container during the material loading processes. The first bag **860** of the supply roll of bags **900** is shown draped over the stacking guides **800a**, **800b**, **800c**, and **800d**. The stacking guides **800a**, **800b**, **800c**, and **800d** act as holders and guides for the bag **860** during the loading process. The center **862** of the bag **860** is positioned over the opening in the top compartment and under a loading tube **890**. The bag holder **1000** in this embodiment includes a pallet jack **1010**, a bag guide **1020** connected to and supported by the pallet jack **1010**, and a supply roll support holder **1030** connected to and supported by the pallet jack **1010**. The bag guide **1020** is sized and configured to hold a bag over the container **50** during the loading process and to prevent the bag from engaging the various components of the container and thus prevent the bag from catching on or ripping from contact with the components of the container. In FIG. **44**, the bag holder **1000** holds the bag **860** over the container **50** with the center of the bag **862** positioned over the opening in the top compartment and under a loading tube **890**. It should be appreciated with respect to FIG. **44** that the cover of the material loading assembly has been removed for ease of illustration.

[0183] Turning now to FIGS. **45** and **46**, another example embodiment of a bag holder of the present disclosure is generally illustrated and indicated by numeral **1100**. The bag holder **1100** is similar to the bag holder **1000** in that it is configured to hold a bag over the shipping container **50** during the material loading process. However, unlike bag holder **1000**, bag holder **1100** is not configured to hold a roll of bags and does not include a supply roll support holder. The bag holder **1100** in this embodiment includes a pallet jack **1010** and a bag guide **1120** connected to and supported by the pallet jack **1010**. The bag guide **1120** is sized and configured to hold a bag over the container **50** during the loading process and to prevent the bag from engaging the

various components of the container and thus prevent the bag from catching on or ripping from contact with the components of the container. In FIG. 46, the bag holder 1000 holds the bag 870 over the container 50 with the center of the bag 872 positioned over the opening in the top compartment and under a loading tube 890. It should be appreciated with respect to FIG. 46 that the cover of the material loading assembly has been removed for ease of illustration.

[0184] It should be appreciated that in both of these bag holder embodiments, the pallet jack 1010 is configured to be positioned underneath the container 50, and specifically that the forks are positioned in the pallet jack tine receiving channels defined by the pallet. It should also be appreciated that the bag holder could alternatively include a fork lift instead of a pallet jack and that in such embodiments, the forks are preferably positioned in the fork lift tine receiving channels defined by the pallet. It should further be appreciated that in alternative embodiments, the bag guides and supply roll support holder can be alternatively supported and positionable. It should be appreciated that the bag guide and supply roll support holder are made from any suitable materials.

[0185] It should also be appreciated that the present disclosure contemplates alternative embodiments (not shown) where the bulk material shipping container is not expandable or retractable. In one such embodiment, the shipping container includes (a) a pallet; (b) a bottom compartment mounted on the pallet; (c) a top compartment securely mounted on the bottom compartment; (d) a material unloading assembly supported by bottom compartment and the pallet; and (e) a material loading assembly attached to the top compartment. In this embodiment, the top compartment is fixed such as by welding to the bottom compartment. This embodiment does not include the plurality of top compartment supporting assemblies or the extension assembly attached to the top compartment. In this embodiment, the bulk material shipping container of the present disclosure can be used with a bag or without a bag.

[0186] In another embodiment (not shown) where the bulk material shipping container is not expandable or retractable, the shipping container includes: (a) a pallet; (b) a single compartment mounted on the pallet; (c) a material unloading assembly supported by the bottom compartment and the pallet; and (d) a material loading assembly attached to the top compartment. Since this embodiment includes a single compartment, this embodiment does not need to include the plurality of compartment supporting assemblies or the extension assembly attached to the top compartment. In this embodiment, the bulk material shipping container of the present disclosure can also be used with a bag or without a bag.

[0187] It should be appreciated that suitable instructional marking or labels may be placed on or attached to the container of the present disclosure to instruct the users on how to load, unload, move, retract, and/or expand the container. It should also be appreciated that suitable reflective tape strips can be attached to the container. It should further be appreciated that the container of the present disclosure can be suitably coated such as by painting with a clear or colored protective coating. It should be appreciated that such coating may include a UV protective agent. It should also be appreciated that one or more sections of the container may be reinforced with a suitable plating to provide additional protection and strength. It should further

be appreciated that the attachment of the various components of the container can be performed in any suitable way such as by welding (including but not limited to laser welding) and by suitable fasteners (such as but not limited to rivets).

[0188] FIGS. 47 to 96B illustrate another example embodiment of the bulk material shipping container of the present disclosure. Similar to the example container 50 described above, this illustrated example shipping container, which is generally indicated by numeral 2050, has an expanded position for holding materials during shipping and a retracted position for efficient shipping when the container 2050 is not holding materials or when the container 2050 is holding a smaller amount of materials. More specifically, FIG. 48 generally illustrates the shipping container 2050 in the retracted or collapsed position, and FIGS. 47, 49, 50, and 51 generally illustrate the shipping container 2050 in the expanded position.

[0189] In this illustrated embodiment, the shipping container 2050 generally includes: (a) a pallet 2100 which is different than pallet 100 as further described below; (b) a bottom compartment 2200 which is different than bottom compartment 200 as further described below; (c) a top compartment 2300 which is different than top compartment 300 as further described below; (d) a plurality of top compartment support assemblies 2400a, 2400b, 2400c (not shown), and 2400d which are different than top compartment support assemblies 400a, 400b, 400c, and 400d as further described below; (e) a material unloading assembly 2500 which is different than material unloading assembly 500 as further described below; (f) a material loading assembly 2600 which is substantially similar to material loading assembly 600 described above; and (g) a top compartment extension assembly 2700 which is substantially similar to top compartment extension assembly 700 described above. It should be appreciated that the following description of the shipping container 2050 will primarily focus on these respective differences.

[0190] In this illustrated embodiment: (a) the pallet 2100 is approximately 56 inches (142.24 centimeters) by approximately 44 inches (111.76 centimeters) by approximately 6 inches (15.24 centimeters); (b) the bottom compartment 2200 is approximately 56 inches (142.24 centimeters) by approximately 44 inches (111.76 centimeters) by approximately 27 inches (68.58 centimeters); and (c) the top compartment 2300 is approximately 56 inches (142.24 centimeters) by approximately 44 inches (111.76 centimeters) by approximately 27 inches (68.58 centimeters).

[0191] In this illustrated embodiment, when the container 2050 is in the retracted position, the container is approximately 56 inches (142.24 centimeters) by approximately 44 inches (111.76 centimeters) by approximately 35 inches (88.90 centimeters).

[0192] In this illustrated embodiment, when the container 2050 is in the expanded position, the container is approximately 56 inches (142.24 centimeters) by approximately 44 inches (111.76 centimeters) by approximately 62 inches (157.48 centimeters). It should be appreciated that this alternative container of the present disclosure can be made in other suitable dimensions.

[0193] More specifically, turning now to FIGS. 47, 48, 49, 50, 51, 53, 54, 60, 61, 62, 63, 64, 65, 66, 67, 90, 91, 92, and 93, the pallet 2100 of this illustrated embodiment of the container 2050 of the present disclosure includes: (a) a

rectangular body **2102** having an upper surface **2104**, a lower surface **2106**, a front edge **2112**, a back edge **2116**, and opposite side edges **2114** and **2118**; (b) a plurality of legs **2121**, **2122**, **2123**, **2124**, **2125**, **2126**, **2127**, and **2128** attached to and extending downwardly from the body **2102**; (c) a footing **2101** attached to and extending downwardly from each of the legs **2121**, **2122**, **2123**, **2124**, **2125**, **2126**, **2127**, and **2128**, and having an upper surface **2103**, a lower surface **2105**, a front edge **2111**, a back edge **2115**, and opposite side edges **2113** and **2117**; (d) a gate head **2150** formed at the front of the body **2102**; and (e) a plurality of compression guards or plates **2160a**, **2160b**, **2160c**, and **2160d** respectively attached to the corners of the upper surface **2104** of the body **2102**. As further described below, the body **2102** of the pallet **2100** functions to directly support the bottom compartment **2200** and indirectly the top compartment **2300**.

[0194] In this illustrated embodiment, the body, legs, and footing of the pallet are each formed from multiple pieces of a suitable wood to: (a) provide structural strength and rigidity; and (b) minimize the overall weight of the pallet and the container. More specifically, in this illustrated embodiment: (a) the rectangular body **2102** is constructed from several individual pieces of wood (such as 2×4s in this example illustrated embodiment); (b) the legs **2121**, **2122**, **2123**, **2124**, **2125**, **2126**, **2127**, and **2128** are each an individual piece of wood (such as 4×4s and 4×6s in this example illustrated embodiment); and (c) the footing **2101** is constructed from several individual pieces of wood (such as 2×2s in this example illustrated embodiment). In this example illustrated embodiment, these individual pieces of wood are suitably attached by fastening mechanisms such as adhesive, nails, and screws. It should be appreciated that these parts may alternatively be formed from more or less pieces, may be formed from other materials, and may be otherwise suitably attached. It should also be appreciated that the pallet may be painted or otherwise protected by other suitable coatings.

[0195] The gate head **2150** is formed at the front of the body **2102**. In this illustrated example embodiment, the front portion of the body **2102** is formed from three pieces of wood including a bottom piece with a cut-out and two spaced-apart top pieces such that the cut-out and the space between the two pieces provide room for the handle of the gate and which limit movement of the gate as further discussed below and as best seen in FIGS. **54**, **60**, **61**, **62**, **63**, **64**, **65**, **66**, **67**, **77**, **78**, and **79**. More specifically, the gate head **2150** of the pallet **2100** includes a handle chamber **2180** and a stopping wall **2182** for the handle **2513** of the gate **2510** material unloading assembly **2500**. The handle chamber **2180** and the stopping wall **2182** of the pallet **2100** are further discussed below in more detail in conjunction with the discussion of the material unloading assembly **2500**.

[0196] The pallet **2100** further includes or defines: (a) a first set of aligned fork lift tine receiving channels **2132a** and **2136a**, respectively; (b) a second set of aligned fork lift tine receiving channels **2132b** and **2136b**, respectively; (c) a first pallet jack tine receiving channel **2140** extending across the pallet **2500** from side to side; and (d) a second pallet jack tine receiving channel **2142** extending across the pallet **2500** from side to side. Similar to the pallet **100** described above, the first set of fork lift tine receiving channels **2132a** and **2136a** and the second set of fork lift tine receiving channels

2132b and **2136b** are positioned and spaced apart such that when the forks or tines of a fork lift are inserted into these channels of the pallet **2100** of the container **2050** which is stacked on top of another container, the tines or forks do not engage the material loading assembly on the top compartment of the lower container or the extension assembly on the top compartment of the lower container. It should thus be appreciated that the pallet **2100** is configured to enable a fork lift to move these containers when one container is stacked on another container without damaging the lower container, and particularly the cover or the extension assembly of the lower container. Also, similar to the pallet **100** described above, the first pallet jack tine receiving channel **2140** and the second pallet jack tine receiving channel **2142** are positioned such that when the forks or tines of a pallet jack are inserted into these channels defined by the pallet **2100** of the container **2050**, they can lift and move the container. As mentioned above, a typical pallet jack does not operate like a fork lift so that the pallet jack will only be used when the container is on the floor or ground and not with stacked containers. Therefore, the tines or forks of a pallet jack will not be in a position to engage the material loading assembly or the extension assembly on the top compartment of the lower container of a set of stacked containers. It should also be appreciated that this illustrated embodiment does not include any legs between the first pallet jack tine receiving channel **2140** and the second pallet jack tine receiving channel **2142**, but that alternative embodiments could include one or more legs or separators between these two channels.

[0197] It should further be appreciated that in this illustrated embodiment the footing **2101** has a smaller rectangular footprint than the body **2102** and the legs **2121**, **2122**, **2123**, **2124**, **2125**, **2126**, **2127**, and **2128** to enable the pallet **2100**, and specifically legs **2121**, **2124**, **2125**, and **2128** of the pallet **2100**, to sit on another container, and specifically to respectively sit on the nesting supports **2840a**, **2842a**, **2840b**, **2842b**, **2840c**, **2842c**, **2840d**, and **2842d** of the top compartment **2300** of another container as best illustrated in FIGS. **89**, **90**, and **91** and as further described in detail below.

[0198] The plurality of compression guards or plates **2160a**, **2160b**, **2160c**, and **2160d** are attached to the respective corners of the body **2102** and are each formed from a suitable stainless steel in this illustrated embodiment. It should be appreciated that the compression guards or plates may alternatively be formed from other suitable materials and in other suitable sizes and configurations. The plurality of compression guards or plates **2160a**, **2160b**, **2160c**, and **2160d** prevent the corners of the bottom compartment **2200** from digging into the body **2102** of the pallet **2100** as best illustrated in FIGS. **92** and **93**.

[0199] It should also be appreciated that this configuration of the pallet enables the pallet (and thus the entire container) to sit on top of known commercially available containers such as the one or more of commercially available Buckhorn containers which are generally described above.

[0200] The bottom compartment **2200** of this example illustrated embodiment includes: (a) a lower exterior bottom wall or panel **2202** defining a material release opening or chute **2204**; (b) an upper interior bottom wall **2210** defined by four attached downwardly angled sections or chute ramps **2212**, **2214**, **2216**, and **2218**; (c) four wedge shaped interior bottom wall supports or gussets **2222**, **2224**, **2226**, and **2228**;

(d) spaced apart first and second or front and back exterior walls **2232** and **2236**; and (e) spaced apart third and fourth or left and right exterior side walls **2234** and **2238**, as generally illustrated in FIGS. **47**, **49**, **50**, **51**, **52**, **54**, **55**, **56**, **57**, **58**, and **59**. The four sections **2212**, **2214**, **2216**, and **2218** of the upper interior bottom wall **210**, the front and back exterior walls **232** and **236**, and the exterior side walls **2234** and **2238** define a bottom compartment material holding area or cavity which extends downwardly toward and to the material release opening or chute **2204**. In this illustrated embodiment, the lower exterior bottom wall **2202**, the upper interior bottom wall **2210**, the interior bottom wall supports **2222**, **2224**, **2226**, and **2228**, the front and back exterior walls **2232** and **2236**, and the exterior side walls **2234** and **2238** are all made of stainless steel or galvanized steel, and are attached by rivets. However, it should be appreciated that in alternative embodiments, one or more of these components can be made from other suitable materials and that these components can be attached or connected in other suitable manners. The exterior bottom wall **2202** of the bottom compartment **2200** is suitably attached to the pallet **2100** of the container **2050** by suitable fasteners as further described below; however, it should be appreciated that the exterior bottom wall can be attached in other suitable manners.

[0201] More specifically, the lower exterior bottom wall **2202** includes: (a) a rectangular substantially flat base **2206** which defines the centrally located rectangular material release opening or chute **2204**; and (b) an upwardly extending lip **2208** extending upwardly from each of outer edges of the base **2206**. The material release opening or chute **2204** enables materials in the top and bottom compartments to flow out of bottom compartment **2200** when the chute door or gate **2510** of the material unloading assembly for the opening or chute **2204** is opened as further discussed below. The opening **2204** in this illustrated embodiment is approximately 8 inches (20.32 centimeters) by approximately 11 inches (27.94 centimeters), although it should be appreciated that the opening may be of other suitable sizes. The opening has four corners which each may have a suitable radius or curve. This size of the opening relative to the size of the bottom and top compartments maximizes the rate of unloading of the material from the top and bottom compartments without sacrificing structure or strength of the bottom compartment.

[0202] The interior bottom wall supports **2222**, **2224**, **2226**, and **2228** are attached in spaced apart locations to the top of the base **2206** by rivets, although they can also or alternatively be otherwise attached. Each of the interior bottom wall supports or gussets **2222**, **2224**, **2226**, and **2228** are of a wedge shape such that they are configured to be engaged by and support a respective one of the downwardly angled sections **2212**, **2214**, **2216**, and **2218** of the upper interior bottom wall **2210**. The gusset **2222** is wider than the other gussets **2224**, **2226**, and **2228** in this illustrated embodiment to distribute the weight of the materials supported by gusset **2222** to the pallet **2100** at further spaced apart locations which are not directly over the gate **2510** of the material unloading assembly **2500** (which is further described below). The upper interior bottom wall **2210**, and specifically the four downwardly angled sections **2212**, **2214**, **2216**, and **2218** are respectively attached to the interior bottom wall supports or gussets **2222**, **2224**, **2226**, and **2228** by rivets, although they can also or alternatively be

otherwise attached. The interior bottom wall supports or gussets **2222** and **2226** are some what shorter than the interior bottom wall supports or gussets **2224** and **2288** to prevent too much weight from being placed on the material unloading assembly **500** and particularly on the gate **2510**. The four downwardly angled sections **2212**, **2214**, **2216**, and **2218** each have a lower edge such that when such sections are attached, such sections form an opening **2211** adjacent to and slightly smaller than but generally substantially aligned with the opening **2204** of the base wall **2206**. In particular, the lower edges of the four downwardly angled sections **2212**, **2214**, **2216**, and **2218** extend downwardly slightly further than the material release opening or chute **2204** of the base wall **2206** of the bottom compartment **2200**. FIGS. **68**, **69**, **70**, **71**, **72**, and **73** best illustrate that the lower edges of the four downwardly angled sections **2212**, **2214**, **2216**, and **2218** define a slightly smaller opening than the opening **2204** defined by the base wall **2206**. This prevents materials stored in the container from getting trapped or positioned between the upper bottom wall and the lower bottom wall.

[0203] The upper interior bottom wall **2210**, and specifically upper portions of the four downwardly angled sections **2212**, **2214**, **2216**, and **2218** are also respectively attached to and supported by the exterior walls **2232**, **2234**, **2236**, and **2238**. It should thus be appreciated that the upper interior bottom wall **210** of the bottom compartment **2200** is supported at multiple locations including multiple points of support by the various different portions of the pallet **2100**. More specifically, the sections **2212**, **2214**, **2216**, and **2218** of the upper interior bottom wall **2210** are supported: (a) at their top ends by the exterior walls **2232**, **2234**, **2236**, and **2238** of the bottom compartment **2200**; (b) centrally by interior bottom wall supports or gussets **2222**, **2224**, **2226**, and **2228**; (c) by attachment to each other; and (d) overall by the pallet **2100**.

[0204] As seen in FIGS. **47**, **48**, **49**, **50**, **51**, **54**, **55**, **77**, and **90**, and as best seen in FIGS. **92** and **93**, the exterior walls **2232**, **2234**, **2236**, and **2238** of the bottom compartment **2200** also each includes a skirt that extends downwardly along a respective different side of the pallet **2100**. Each skirt includes a plurality of fastener slots or oval screw holes which are configured to facilitate movement of each exterior wall and particularly the skirt relative to the fasteners. More specifically, as seen in FIGS. **92** and **93**, suitable fasteners such as screws are used to attach each skirt to the respective side of the pallet **2100** and particularly the body **2102** of the pallet **2100** to support these exterior walls. In FIG. **92**, the container **2050** is collapsed and is empty and the skirt is positioned such that the screws are respectively at the bottom of the slots. In FIG. **93**, the container **2050** is collapsed and is filled and the skirt has moved downwardly relative to the body **2102** of the pallet **2100** and is positioned such that the screws are at the top of the slots. The skirts of the exterior walls, and thus the entire the exterior walls of the bottom container have moved downwardly relative to the pallet and particularly relative to the body **2102** of the pallet **2100**. It should be appreciated that the bottom compartment is thus configured to move relative to the pallet when filled. It should also be appreciated that the slots may be of different sizes such that in these positions, the screws are adjacent to but not at the tops or bottoms of the slots.

[0205] As generally illustrated in FIGS. **47**, **48**, **49**, **50**, **51**, **52**, **53**, **54**, **55** and as best illustrated in FIGS. **80**, **81**, **82**, **83**, **95A**, **95B**, **96A**, and **96B**, each of the exterior walls **2232**,

2234, **2236**, and **2238** of the bottom compartment **2210** each include a rectangular panel and two L-shaped corner sections attached to opposite ends of the rectangular panel. Each L-shaped corner section of each panel of each exterior wall is configured to mate with the L-shaped corner of an adjacent exterior wall. These L-shaped corner sections of each of the exterior side wall: (a) are preferably connected rivets; (b) add structural rigidity to the bottom compartment; and (c) in conjunction with the top compartment support assemblies (discussed below) provide support for the top compartment when the top compartment is in the expanded position as further described below.

[0206] More specifically, as illustrated in FIGS. **80**, **81**, **82**, **83**, **95A**, **95B**, **96A**, and **96B**, exterior side wall **2232** includes panel **2252** and corner **2262** which includes corner sections **2262a** and **2262b**, and exterior side wall **2234** includes panel **2254** and corner **2264** which includes corner sections **2264a** and **2264b**. Corner sections **2264a** is mated with and attached to corner section **2262a**, and corner section **2264b** is mated with and attached to corner section **2262b** to form this corner of the bottom compartment **2200**. It should be appreciated that each corner of the bottom compartment is preferably configured in a similar manner. In this illustrated embodiment, each of the exterior walls **2232**, **2234**, **2236**, and **2238** of the bottom compartment **2210** also includes a top edge which is curled or bent over to provide extra strength to the bottom compartment and to minimize interference with movement of the top compartment **2300** relative to the bottom compartment **2200**. These corners and the top compartment support assemblies are further described below.

[0207] Turning now to FIGS. **47**, **48**, **50**, **51**, **52**, and **54**, the top compartment **2300** of the container **2050** includes an exterior top wall **2302**, spaced apart exterior front and back side walls **2312** and **2316**, spaced apart exterior side walls **2316** and **2318**, and exterior wall support brackets **2322**, **2324**, **2326**, and **2328** respectively attached to the exterior side walls **2312**, **2314**, **2316**, and **2318**. In this illustrated embodiment, the exterior top wall **2302**, exterior side walls **2312**, **2314**, **2316**, and **2318**, and exterior wall support brackets **2322**, **2324**, **2326**, and **2328** are also all made of stainless steel or galvanized steel. The upper interior base wall **2306** is suitably attached to the upper portions of the exterior walls **2312**, **2314**, **2316**, and **2318** by rivets. The exterior wall support brackets **2322**, **2324**, **2326**, and **2328** are respectively attached to the exterior side walls **2312**, **2314**, **2316**, and **2318** by rivets. However, it should be appreciated that in alternative embodiments, one or more of these components can be made from other suitable materials and attached or connected in any suitable manner. The upper interior base wall **2306** and the exterior walls **2312**, **2314**, **2316**, and **2318** define a top compartment material holding area or cavity which extends downwardly to the bottom compartment material holding area or cavity.

[0208] As with container **50**, the exterior top wall **2302** of container **2050** includes a rectangular substantially flat base which defines the centrally located rectangular material receipt or loading opening or chute (not shown in FIGS. **47** to **96B**). This material receipt or loading opening or chute enables materials to flow into the top and bottom compartments when the cover of the material loading assembly is opened. The opening in this embodiment is 18 inches (45.72

centimeters) by 18 inches (45.72 centimeters), although it should be appreciated that the opening may be of other suitable sizes.

[0209] As best illustrated in FIGS. **95A**, **95B**, **96A**, and **96B**, similar to the configuration of the bottom compartment, each of the exterior walls **2312**, **2314**, **2316**, and **2318** of the top compartment **2300** include a rectangular panel and two L-shaped corner sections attached to opposite ends of the panel. Each L-shaped corner section of each panel of each exterior wall is configured to mate with the L-shaped corner of the adjacent exterior wall similar to the bottom compartment. These L-shaped corner sections of each of the exterior side wall of the top compartment are preferably connected by welding and add structural rigidity to the top compartment.

[0210] More specifically, as illustrated in FIGS. **95A**, **95B**, **96A**, and **96B**, exterior side wall **2312** includes panel **2352** and corner **2362** which includes corner sections **2362a** and **2362b**, and exterior side wall **2314** includes panel **2354** and corner **2364** which includes corner sections **2364a** and **2364b**. Corner sections **2364a** is mated with and attached to corner section **2362a**, and corner section **2364b** is mated with and attached to corner section **2362b** to form this corner of the top compartment **2300**. It should be appreciated that each corner of the top compartment is preferably configured in a similar manner. In this illustrated embodiment, each of the exterior walls **2312**, **2314**, **2316**, and **2318** of the bottom compartment **2210** also includes a top edge which is curled or bent over to provide extra strength to the top compartment **2300**.

[0211] FIGS. **95A** and **96A** illustrate the position of these walls and corners of the top and bottom compartments when the container is empty and the container is in the expanded position. It should be appreciated that the exact amount of the space between the corners of the top and bottom compartments can vary in accordance with the present disclosure and in accordance with manufacturing tolerances. The figures illustrate that when the container **2050** is empty, the corner of the top compartment can relatively easily move vertically relative to the corner of the bottom compartment.

[0212] FIGS. **95B** and **96B** illustrate the position of these walls and corners of the top and bottom compartments when the container is full and the container is in the expanded position. These figures illustrate that when the container **2050** is full, the wall panels of the top and bottom compartment are configured to bow outwardly as very generally illustrated in FIG. **94** and that an engagement is created or formed between the sections of the corners of the top and bottom compartments as generally illustrated in FIGS. **95B** and **96B**. This engagement of the corners causes the corners of the top compartment to engage and grip the corners of the bottom compartment, which holds the relative position of the top compartment to the bottom compartment (in addition to the support provided by the top compartment support assemblies as further discussed below.) It should also be appreciated that this top corner to bottom corner engagement may happen at one corner, more than one corner, or all of the corners of the container. It should also be appreciated that this corner engagement may occur in the embodiment of FIGS. **1** to **46** described above.

[0213] Turning now to FIGS. **47**, **48**, **49**, **50**, **53**, **54**, **58**, **59**, **60**, **61**, **65**, **66**, **67**, **68**, **69**, **70**, **71**, **72**, **73**, **74**, **75**, **76**, **77**, **78**, and **79**, the material unloading assembly **2500** of the container **2050** is supported by the bottom wall **2206** of the

bottom compartment **2200** adjacent to the opening or chute **2204** in the bottom compartment **2200** and above the opening **2170** in the pallet **2100**. The material unloading assembly **2500** generally includes a chute door or gate **2510** slidably positioned on the guide rails **2163**, **2165**, **2167**, and **2169**. In this illustrated embodiment, the gate **2510** and the guide rails are **2163**, **2165**, **2167**, and **2169** are made of stainless steel or galvanized steel. However, it should be appreciated that in alternative embodiments, the gate and the guide rails can be made from other suitable materials.

[0214] The guide rails **2163**, **2165**, **2167**, and **2169** are each respectively attached to the bottom exterior surface of the bottom wall **2206**. It should be appreciated that FIGS. **60**, **61**, **65**, **66**, and **67** illustrate these guide rails **2163**, **2165**, **2167**, and **2169** detached from or without the exterior bottom wall **2206** to show how they are positioned with respect to the pallet **2100** and the opening **2170** defined by the pallet **2100**. The guide rails **2163**, **2165**, **2167**, and **2169**, support and guide the movement of closure portion **2516** and the handle portion **2512** of the chute door or gate **2510**. The gate **2510** slides or moves above and on these guide rails **2163**, **2165**, **2167**, and **2169**, and these guide rails prevent the downward movement of the chute door or gate when the container is full and also prevent loose materials being held in the top and bottom compartments from accumulating on or adjacent to the chute door or gate. The guide rails **2165** and **2169** include stops or stopping members which prevent the gate from moving outwardly too far and are generally illustrated in FIGS. **65**, **66**, and **67**.

[0215] The gate **2510** includes a handle member or portion **2512** and a closure member or portion **2516** extending from the handle member or portion **2512** as best illustrated in FIGS. **74**, **75**, and **76**. The gate **2510** is movable or slidable from a closed position as shown in FIGS. **47**, **48**, **49**, **50**, **53**, **54**, **58**, **59**, **65**, **68**, and **69**, to a plurality of different partially open positions (such as the partially open position shown in FIGS. **66**, **70**, and **71**), and then to a fully open position shown in FIGS. **67**, **72**, and **73**. It should be appreciated that in this illustrated embodiment, the gate does not rest on the pallet, but that in other embodiments, the gate or portions of the gate may rest on portions of the pallet.

[0216] It should also be appreciated that the body **2102** of the pallet **2100** also defines a plurality of stopping walls (as best seen in FIGS. **65**, **66** and **67**) that would prevent the gate **2510** from moving too far outwardly and which also secondarily keep the handle portion **2512** of the gate **2510** relatively close to the pallet **2100**. It should further be appreciated that the body **2102** of the pallet **2100** also provides a stopping walls **2182** that prevents the gate **2510** from moving too far inwardly.

[0217] It should be appreciated that this illustrated example embodiment of the material unloading assembly **2500** does not include a knife as in the embodiments described above. However, it should be appreciated that an alternative of this embodiment could alternatively include one or more knives.

[0218] The material unloading assembly **2500** also includes a locking assembly **2550** configured to enable a user to lock the gate **2510**, and specifically the handle portion **2512** of the gate **2510** to the stopping wall **2182** of the pallet **2510** to prevent the handle portion **2512** and the gate **2510** from being accidentally opened at undesired points in time such as: (a) during loading of the container **2050**; (b) during transit of the container **2050**; or (c) at any

other point in time prior to an unloader opening the gate **2510**. More specifically, as seen in FIGS. **47**, **48**, **49**, **50**, **53**, **54**, **58**, **59**, **65**, **66**, **67**, **68**, **70**, **74**, **76**, **77**, **78** and **79**, the **60** handle portion **2512** of the gate **2510** includes a downwardly extending handle **2513** which is configured to be gripped by a user to open and close the gate **2510**. The downwardly extending handle **2513** defines a locking pin slot or opening **2514** (best seen in FIGS. **59**, **67**, and **77**) configured such the locking pin **2590** can extend through the locking pin opening or slot **2514**. The material unloading assembly **2500** also includes a stopping bracket **2560** attached to the bottom surface of the stopping wall **2182** as best seen in FIGS. **68**, **70** and **72**. The stopping bracket **2560** includes an opening aligned with the opening **2514** of the handle **2513** of the handle portion **2512** of the gate **2510**. More specifically, the material unloading assembly **2500** further includes a locking pin **2590** configured to be inserted through: (a) the locking pin slot or opening **2514** of the handle **2513** of the handle portion **2512** of the gate **2510**; and (b) the opening in the stopping bracket **2560** when the gate **2510** is in the closed position. This locking pin **2590** engages the stopping bracket **2560** to prevent unwanted opening of the gate **2510**. When the user desires to open the gate **2510**, the user activates the locking pin **590** and removes the locking pin **2590** from the stopping bracket **2560**. It should be appreciated that although not shown, the locking pin **2590** can be tethered to the handle **2513** of the gate **2510** by a suitable tether (not shown). It should also be appreciated that the locking pin can be placed in a different hole in the handle of the gate **2510**. It should further be appreciated, that although not shown, the material unloading assembly can further include one or more guides for holding the locking pin **2590** level or otherwise in position for easy re-insertion when the gate **2510** is in a fully open or partially open position. It should be appreciated that the locking pin can be any suitable locking pin. It should also be appreciated, that although not shown a suitable tether can be employed to maintain the locking pin attached to the gate or container.

[0219] It should also be appreciated that by pushing the handle back toward the closed position, the chute can be closed or partially closed. It should also be appreciated that placing the handle in a partially open or partially closed positioned enables the user to control the rate of emptying the materials from the container **2050**. It should also be appreciated that the pallet or bottom container can include a loop or hole that corresponds to a hole in the handle **2513** for receiving a tamper identification seal or lock.

[0220] As mentioned above, the top compartment **2300** is supported by a plurality of top compartment supporting assemblies **2400a**, **2400b**, **2400c** (not shown), and **2400d** which are each configured to support a different one of the corners of the top compartment **2300** and to hold the top compartment **2300** in the expanded position as illustrated in FIGS. **47**, **49**, **50**, **51**, **83**, **84**, **85**, **86**, and **84**. In the illustrated embodiment, each top compartment support assembly **2400a**, **2400b**, **2400c**, and **2400d** is identical; however, it should be appreciated that two or more of these support assemblies may be different. Support assembly **2400a** is discussed herein as an example.

[0221] Support assembly **2400a** includes a support pin **2410a** configured to be inserted through a pin receipt or pin receipt hole (not shown) in the respective corner of the bottom compartment **2200** and into a tubular support pin receiver or sleeve **2412a** of the support assembly **2400a**

which is attached to a support bracket **2413a** which is suitably attached (such as by welding) to the inside of the corner of the bottom compartment **2200** as best illustrated in FIG. **85**. The illustrated support pin **2410a** includes a head, a collar attached to the head and a body extending from the collar, and a locking mechanism with a push button disposed in the head. The bottom edges of the corners of the top compartment are configured to rest on the bodies of these support pins. However, it should be appreciated that other support pins may be employed in accordance with the present disclosure.

[0222] The support assembly **2400a** further includes a combined support bracket and pin holder **2430a** and a tether **2460a** (shown in FIG. **94**) attaching the pin **2420a** to the combined support bracket and holder **2430a**. It should be appreciated that the combined support bracket and pin holder **2430a** and the tether **2460a** are partially employed to prevent the support pin **2410a** from being lost and to hold the support pin **2410a** out of the way of the bottom compartment **2200** when the support pin **2410a** is not in use.

[0223] More specifically, in the illustrated embodiment, the combined support bracket and pin holder **2430a** is substantially more robust than the support pin holder **430a** of container **50** described above. Combined support bracket and pin holder **2430a** includes two mounting members **2432a** and **2433a** suitably attached to the corner of the top compartment **2300** and a pin holder **2434a** connected to the mounting members **2432a** and **2433a**. The pin holder **2434a** defines a first hole for attachment of the one end of the tether and a second hole for removably holding the support pin when the support pin is not in use. The combined support bracket and pin holder **2430a** is made from stainless steel or galvanized steel, and riveted to the corner of the top compartment **2300**. It should be appreciated that the combined support bracket and holder could be made from other suitable materials, could be suitably attached to the top compartment in other suitable manners and could be alternatively configured. It should also be appreciated that each combined support bracket and pin holder is configured to provide additional support for the top compartment when the top compartment rest on the support pins.

[0224] Similar to tether **460a** described above, tether **2460a** includes one end loop is attached to the combined support bracket and holder **2430a** and another end loop is attached to the support pin. Each tether may be any suitable length and made from any suitable material such as steel or a high strength plastic.

[0225] The support pin **2410a** in the illustrated embodiment is similar to the pin described above. It should be appreciated that other suitable support pins may be employed with the container in accordance with the present disclosure.

[0226] As mentioned above, the container **2050** includes an extension assembly **2700** which enables a user or loader to move the top compartment from the retracted position to the expanded position to enable insertion of the support pins. The extension assembly **2700** of the container **2050** is identical to the extension assembly **700** of the container **50**, and thus will only generally be described. Generally, as illustrated in FIGS. **47**, **48**, **50**, **52**, and **54**, the extension assembly **2700** includes a first set of aligned fork lift tine receiving loops or lifting brackets **2702** and **2704** and a second set of aligned forklift tine receiving loops or lifting brackets **2706** and **2708**. Each of the lift tine receiving loops

or lifting brackets **2702**, **2704**, **2706**, and **2708** are identical in this illustrated embodiment, but it should be appreciated that these components can be different. In this embodiment, these loops or lifting brackets are made of stainless steel or galvanized steel and the mounting bars are each suitably riveted to the top wall **2302** of the top compartment **2300**. The loops or lifting brackets are suitably aligned to form two slots configured to receive forklift forks or tines. It should be appreciated that these brackets can be made of other suitable materials and attached in other suitable manners.

[0227] The material loading assembly **2600** is similar to the material loading assembly **600** of container **50** and thus will only be generally described. FIGS. **47**, **48**, **50**, **51**, **52**, and **54**, generally illustrate that the material loading assembly **2600** is attached to the top compartment **2300** and generally includes: (a) an upwardly extending lip (not shown) attached to and extending from the top wall **2302** of the top compartment **2300**; (b) a cover **2610** configured to securely engage the upwardly extending lip and pivotally attached to the top wall **2302** of the top compartment **2300** by hinge **2630**; (c) a lock assembly **2650** including a first portion attached to the top wall **2302** of the top compartment **2300** and a second portion or lid latch attached to the cover **2610**; (d) and a gasket (not shown) mounted in the cover **2610** to seal out contaminants. The locking assembly **2650** includes a suitable lock (not shown) which is used to lock the cover **2610** in the closed position, and specifically to lock the second portion or lid latch attached to the cover to the first portion attached to the top wall **2302** of the top compartment **2300**.

[0228] As mentioned above, the container **2050** and specifically the top compartment **2300** includes a plurality of nesting or stacking or guides **2800a**, **2800b**, **2800c**, and **2800d** which are configured to facilitate secure stacking of the containers of the present disclosure as well as stacking of other known bulk material containers as illustrated in FIGS. **47**, **48**, **49**, **50**, **51**, **52**, **54**, **88**, **89**, **90**, and **91**. In the illustrated embodiment, each of the stacking guides **2800a**, **2800b**, **2800c**, and **2800d** is identical; however, it should be appreciated that two or more of these stacking guides may be different. More specifically, stacking guide **2800a** is discussed herein as an example stacking guide. As best shown in FIG. **88**, stacking guide **2800a** includes mounting walls **2802a** and **2804a** configured to be attached to the corner of the top compartment **2300** and guide wall **2812a** and **2814a** respectively attached to and extend from the mounting walls **2802a** and **2804a**. In this illustrated embodiment, the guide wall **2812a** and **2814a** each respectively define openings **2820a** and **2822a**. As generally shown in FIGS. **90** and **91**, the stacking guides assist in positioning one container of the present disclosure on top of another container of the present disclosure.

[0229] FIG. **89** illustrates one corner of the top compartment **2300** of the container **2050** with a nesting guide **2800a** and two nesting supports **2840a** and **2842a** adjacent to and attached to the nesting guide **2800a**. In this illustrated example, the nesting supports **2840a** and **2842a** are each made from a steel tubular material and are attached by rivets to the nesting guide **2800a**. It should be appreciated that the nesting supports can be made from other suitably strong materials and can be attached to the nesting guide in other suitable manners such as by welding. When a second container sits on a first container as generally illustrated in FIGS. **90** and **91**, the pallet of the second or top container

rests on the nesting supports **2840a** and **2842a** of the first or bottom container which are configured to support the pallet and specifically the legs of the pallet of the second container. The nesting supports direct the weight of the second or top container that sits on those nesting supports to the corners of the first or bottom container rather than the entire side walls or edges of the first or bottom container. This prevents the weight of the second or top container from damaging the walls of the top compartment of the first or bottom container and provides for a better nesting of compatible containers.

[0230] FIG. 91 shows the leg **2124** of the pallet **2100** sitting on the nesting supports **2842a** and **2840a** adjacent to the nesting guide **2800a**. FIG. 91 also shows a small gap under the footing **2101** attached to the bottom of the legs of the pallet **2100** and that the footing does not rest on the nesting supports and does not rest on the top wall of the top compartment. This configuration prevents too much weight from the second or top pallet from being placed on the top wall of the top compartment of the first or bottom pallet.

[0231] This example embodiment of the shipping container of the present disclosure is configured to directly hold materials or to receive and hold a large plastic bag or a sleeve which holds the materials in the interior areas defined by bottom and top compartments. In one embodiment, the same bag as the bag described above can be employed. When a bag is employed with this container **2050**, it is expected that a knife will also be employed in the material unloading assembly.

[0232] In other embodiments, instead of a bag, a sleeve is employed as generally illustrated in FIG. 87. In one such embodiment, the sleeve includes four connected walls where each wall is approximately 45 inches (114.30 centimeters) by approximately 56 inches (142.24 centimeters). In one embodiment, the sleeve has no bottom or top walls. In one embodiment, the sleeve: (a) is FDA compliant; (b) has an approximately 2 millimeter thickness; (c) is opaque or gray; and (d) is made from a low density recyclable polyethylene plastic. In one alternative embodiment, the sleeve is also or alternatively bio-degradable. It should be appreciated that in various embodiments the sleeve will be appropriately folded so that the sleeve can be unfolded and positioned in the top and bottom compartments of the container. FIG. 87 shows the top compartment **2300** removed from the bottom compartment and the generally rectangular sleeve **2900** extending downwardly from the top compartment **2300**. This sleeve **2900** includes double-sided tape (not shown) on the outside walls of its top end for attachment of the sleeve to the inner surfaces of the walls of the top compartment. In practice, to install a sleeve, an operator would: (a) remove the top compartment from the bottom compartment; (b) clean the interior walls of both top and bottom compartments if necessary; (c) unfold the sleeve, and attach the sleeve to the inner wall surfaces of the top compartment; (d) move the top compartment with the sleeve hanging down over the bottom compartment; and (e) lower the sleeve into the bottom compartment and reconnect the top compartment to the bottom compartment such the sleeve is in the bottom and top compartments.

[0233] In another embodiment (not shown), the bulk material shipping container is similar to container **2050** but is not expandable or retractable. This example shipping container includes: (a) a pallet similar to pallet **2100**; (b) a single compartment mounted on the pallet; (c) a material unloading assembly supported by the bottom compartment and similar

to material unloading assembly **2500**; and (d) a material loading assembly attached to the top of the compartment similar to material loading assembly **2600**. Since this embodiment includes a single compartment, this embodiment does not need to include the plurality of top compartment supporting assemblies or the extension assembly. In this embodiment, the bulk material shipping container of the present disclosure can also be used with a bag, with a sleeve, or without a bag or sleeve.

[0234] In another embodiment partially shown in FIG. 97, the bulk material shipping container is not expandable or retractable and does not include a top wall. In this embodiment, the shipping container **3050** includes: (a) a pallet (not shown) similar to pallet **2100**; (b) a single compartment **3300** mounted on the pallet; and (c) a material unloading assembly (not shown) supported by the bottom compartment and similar to material loading assembly **2500**. Since this embodiment includes a single compartment, this embodiment does not need to include the plurality of top compartment supporting assemblies or the extension assembly. In this embodiment, the bulk material shipping container of the present disclosure can also be used with a bag, with a sleeve, or without a bag or a sleeve. Additionally, in this illustrated embodiment, the compartment is formed without a top wall. End caps or channels **3352**, **3354**, **3356**, and **3358** are respectively positioned over the top edges of the side walls **3312**, **3314**, **3316**, and **3318** to protect and strengthen the top edges of the compartment. The nesting guides **3800a** (not shown), **3800b**, **3800c**, and **3800d** are configured to provide additional engagements with the corners of the top of the compartment to sufficiently support the nesting supports. In this embodiment, multiple containers with open top ends can be stacked on each other and unloaded together when the material unloading assemblies are all opened with the containers stacked on each other.

[0235] It should be appreciated that the present disclosure contemplates the elimination or reduction of sharp edges in the compartment and that any sharp edges can be curved or formed with a suitable radius.

[0236] It should be understood that modifications and variations may be effected without departing from the scope of the novel concepts of the present disclosure, and it should be understood that this application is to be limited only by the scope of the appended claims.

The invention is hereby claimed as follows:

1. A material shipping container comprising:
 - a pallet defining spaced apart nine receiving openings extending from a front side of the pallet to a back side of the pallet, the pallet including:
 - (i) a first bottom corner leg,
 - (ii) a second bottom corner leg,
 - (iii) a third bottom corner leg,
 - (iv) a fourth bottom corner leg, wherein the first bottom corner leg, the second bottom corner leg, the third bottom corner leg, and the fourth bottom corner leg have a first footprint,
 - (v) a front connection member connected to the first bottom corner leg and the second bottom corner leg,
 - (vi) a back connection member connected to the third bottom corner leg and the fourth bottom corner leg,
 - (vii) a first side connection member connected to the second bottom corner leg and the third bottom corner leg,

- (viii) a second side connection member connected to the first bottom corner leg and the fourth bottom corner leg, wherein the front connection member, the back connection member, the first side connection member, and the second side connection member have a second footprint, and wherein the first footprint is greater than the second footprint;
- a compartment mounted on the pallet, the compartment having a first top corner, a second top corner, a third top corner, and a fourth top corner, the compartment including:
- (a) a top wall,
 - (b) a front exterior wall,
 - (c) a back exterior wall spaced apart from the front exterior wall,
 - (d) a first exterior side wall,
 - (e) a second exterior side wall spaced apart from the first exterior side wall,
 - (f) a front exterior wall support bracket connected to an exterior side of the front exterior wall,
 - (g) a back exterior wall support bracket connected to an exterior side of the back exterior wall,
 - (h) a first side exterior wall support bracket connected to an exterior side of the first exterior side wall,
 - (i) a second side exterior wall support bracket connected to an exterior side of the second exterior side wall,
 - (j) an interior bottom wall including:
 - (i) a front downwardly angled section attached to the front exterior wall and having a lower edge,
 - (ii) a back downwardly angled section attached to the back exterior wall and having a lower edge,
 - (iii) a first side downwardly angled section attached to the first exterior side wall, the front downwardly angled section, and the back downwardly angled section, and having a lower edge, and
 - (iv) a second side downwardly angled section attached to the second exterior side wall, the front downwardly angled section, and the back downwardly angled section, and having a lower edge,
 - (k) a first nesting support positioned at the first top corner of the compartment,
 - (l) a second nesting support positioned at the second top corner of the compartment,
 - (m) a third nesting support positioned at the third top corner of the compartment, and
 - (n) a fourth nesting support positioned at the fourth top corner of the compartment, the first, second, third, and fourth tubular nesting supports configured to at least partially support a pallet of a second material shipping container such that a second compartment of the second material shipping container is spaced apart from the top wall of the compartment,
- said compartment further defining a material release opening at a bottom of the compartment;
- a material unloading assembly positioned at the bottom of the compartment, the material unloading assembly including:
- (i) spaced apart guide rails, and
 - (ii) a slidable gate including a closure member and an engagable member extending in an area lower than the closure member and attached to and supported by the closure member, the closure member at least partially supported by the spaced apart guide rails,
- the engagable member movable in a first direction toward the front side of the pallet to cause the closure member to allow material in the compartment to flow through the material release opening, and the engagable member movable in a second different direction toward the back side of the pallet to cause the closure member to prevent material in the compartment from flowing through the material release opening; and
- a material loading assembly attached to the top wall of the compartment, the material loading assembly including a cover hingedly attached to the top wall of the compartment along an axis transverse to an axis extending from the front side of the pallet to the back side of the pallet, the cover rotatable from a closed position to an open position, the cover remaining hingedly attached to the top wall of the compartment in the open position.
2. The material shipping container of claim 1, which includes:
- (i) a front wedge shaped bottom wall support which partially supports the front downwardly angled section between opposing spaced apart side edges of the front downwardly angled section,
 - (ii) a back wedge shaped bottom wall support which partially supports the back downwardly angled section between opposing spaced apart side edges of the back downwardly angled section,
 - (iii) a first side wedge shaped bottom wall support which partially supports the first side downwardly angled section between opposing spaced apart side edges of the first side downwardly angled section, and
 - (iv) a second side wedge shaped bottom wall support which partially supports the second side downwardly angled section between opposing spaced apart side edges of the second side downwardly angled section.
3. The material shipping container of claim 1, wherein each of the nesting supports includes a generally rectangular tubular section.
4. The material shipping container of claim 1, wherein:
- (a) the front exterior wall and the first side exterior wall form a W-shaped first corner section,
 - (b) the front exterior wall and the second side exterior wall form a W-shaped second corner section,
 - (c) the back exterior wall and the first side exterior wall form a W-shaped third corner section, and
 - (d) the back exterior wall and the second side exterior wall form a W-shaped fourth corner section.
5. The material shipping container of claim 1, wherein the compartment is entirely supported by the pallet.
6. A material shipping container comprising:
- a pallet defining spaced apart time receiving openings extending from a front side of the pallet to a back side of the pallet, the pallet including:
- (i) a first bottom corner leg,
 - (ii) a second bottom corner leg,
 - (iii) a third bottom corner leg,
 - (iv) a fourth bottom corner leg, wherein the first bottom corner leg, the second bottom corner leg, the third bottom corner leg, and the fourth bottom corner leg have a first footprint,
 - (v) a front connection member connected to the first bottom corner leg and the second bottom corner leg,
 - (vi) a back connection member connected to the third bottom corner leg and the fourth bottom corner leg,

- (vii) a first side connection member connected to the second bottom corner leg and the third bottom corner leg,
 - (viii) a second side connection member connected to the first bottom corner leg and the fourth bottom corner leg, wherein the front connection member, the back connection member, the first side connection member, and the second side connection member have a second footprint, and wherein the first footprint is greater than the second footprint;
- a compartment mounted on the pallet, the compartment having a first top corner, a second top corner, a third top corner, and a fourth top corner, the compartment including:
- (a) a top wall,
 - (b) a front exterior wall,
 - (c) a back exterior wall spaced apart from the front exterior wall,
 - (d) a first exterior side wall,
 - (e) a second exterior side wall spaced apart from the first exterior side wall,
 - (f) a front exterior wall support bracket connected to an exterior side of the front exterior wall,
 - (g) a back exterior wall support bracket connected to an exterior side of the back exterior wall,
 - (h) a first side exterior wall support bracket connected to an exterior side of the first exterior side wall,
 - (i) a second side exterior wall support bracket connected to an exterior side of the second exterior side wall,
 - (j) a steel interior bottom wall including:
 - (i) a front downwardly angled section attached to the front exterior wall and having a lower edge,
 - (ii) a back downwardly angled section attached to the back exterior wall and having a lower edge,
 - (iii) a first side downwardly angled section attached to the first exterior side wall, the front downwardly angled section, and the back downwardly angled section, and having a lower edge, and
 - (iv) a second side downwardly angled section attached to the second exterior side wall, the front downwardly angled section, and the back downwardly angled section, and having a lower edge,
 - (k) a steel first nesting support positioned at the first top corner of the compartment,
 - (l) a steel second nesting support positioned at the second top corner of the compartment,
 - (m) a steel third nesting support positioned at the third top corner of the compartment, and
 - (n) a steel fourth nesting support positioned at the fourth top corner of the compartment, the first, second, third, and fourth tubular nesting supports configured to at least partially support a pallet of a second material shipping container such that a second compartment of the second material shipping container is spaced apart from the top wall of the compartment,
- said compartment further defining a material release opening at a bottom of the compartment;
- a material unloading assembly positioned at the bottom of the compartment, the material unloading assembly including:
- (i) steel spaced apart guide rails, and
 - (ii) a steel slidable gate including a closure member and an engagable member extending in an area lower than the closure member and attached to and supported by the closure member, the closure member at least partially supported by the spaced apart guide rails, the engagable member movable in a first direction toward the front side of the pallet to cause the closure member to allow material in the compartment to flow through the material release opening, and the engagable member movable in a second different direction toward the back side of the pallet to cause the closure member to prevent material in the compartment from flowing through the material release opening; and
- a material loading assembly attached to the top wall of the compartment, the material loading assembly including a steel cover hingedly attached to the top wall of the compartment along an axis transverse to an axis extending from the front side of the pallet to the back side of the pallet, the cover rotatable from a closed position to an open position, the cover remaining hingedly attached to the top wall of the compartment in the open position.
- 7.** The material shipping container of claim **6**, which includes:
- (i) a steel front wedge shaped bottom wall support which partially supports the front downwardly angled section between opposing spaced apart side edges of the front downwardly angled section,
 - (ii) a steel back wedge shaped bottom wall support which partially supports the back downwardly angled section between opposing spaced apart side edges of the back downwardly angled section,
 - (iii) a steel first side wedge shaped bottom wall support which partially supports the first side downwardly angled section between opposing spaced apart side edges of the first side downwardly angled section, and
 - (iv) a steel second side wedge shaped bottom wall support which partially supports the second side downwardly angled section between opposing spaced apart side edges of the second side downwardly angled section.
- 8.** The material shipping container of claim **6**, wherein each of the nesting supports includes a generally rectangular tubular section.
- 9.** The material shipping container of claim **6** wherein:
- (a) the front exterior wall and the first side exterior wall form a W-shaped first corner section,
 - (b) the front exterior wall and the second side exterior wall form a W-shaped second corner section,
 - (c) the back exterior wall and the first side exterior wall form a W-shaped third corner section, and
 - (d) the back exterior wall and the second side exterior wall form a W-shaped fourth corner section.
- 10.** The material shipping container of claim **6**, wherein the compartment is entirely supported by the pallet.