



US012001002B2

(12) **United States Patent**
Hawes et al.

(10) **Patent No.:** **US 12,001,002 B2**
(45) **Date of Patent:** **Jun. 4, 2024**

(54) **SLIDE IMAGING APPARATUS**
(71) Applicant: **VENTANA MEDICAL SYSTEMS, INC.**, Tucson, AZ (US)
(72) Inventors: **William Roland Hawes**, Hertfordshire (GB); **Jagdish Pankhania**, Harrow (GB)
(73) Assignee: **VENTANA MEDICAL SYSTEMS, INC.**, Tucson, AZ (US)
(*) Notice: Subject to any disclaimer, the term of this patent is extended or adjusted under 35 U.S.C. 154(b) by 311 days.

(56) **References Cited**
U.S. PATENT DOCUMENTS
4,248,498 A * 2/1981 Georges G02B 21/26 356/244
4,453,807 A 6/1984 Faulkner et al.
(Continued)
FOREIGN PATENT DOCUMENTS
CN 101159138 4/2008
CN 103796728 5/2014
(Continued)

(21) Appl. No.: **17/529,974**
(22) Filed: **Nov. 18, 2021**
(65) **Prior Publication Data**
US 2022/0075174 A1 Mar. 10, 2022

OTHER PUBLICATIONS
<https://www.youtube.com/watch?v=hrUIBHU8xE>, video describing the Leica Microsystems Lica SCN400 with Leica SL801, Feb. 3, 2011, retrieved segments May 9, 2022, 16 pages.
(Continued)

Related U.S. Application Data
(63) Continuation of application No. 16/477,834, filed as application No. PCT/EP2018/050567 on Jan. 10, 2018, now Pat. No. 11,231,574.

Primary Examiner — Mustak Choudhury
(74) *Attorney, Agent, or Firm* — Kilpatrick Townsend & Stockton LLP

(30) **Foreign Application Priority Data**
Jan. 13, 2017 (EP) 17151434.2

(57) **ABSTRACT**
A slide imaging apparatus that includes a copy holder moving system and an imaging system. The copy holder moving system includes a movable stage configured to move along first and second slide movement axes relative to the imaging system, wherein the imaging system is configured to form an image of a sample mounted on a slide located in the/each imaging location on the movable stage during an image forming process that includes the movable stage moving relative to the imaging system along the first and second slide movement axes. The copy holder moving system also includes a copy holder configured to be mounted to the movable stage, wherein the copy holder is configured to be mounted to the movable stage in each of a plurality of indexing positions.

(51) **Int. Cl.**
G02B 21/26 (2006.01)
(52) **U.S. Cl.**
CPC **G02B 21/26** (2013.01)
(58) **Field of Classification Search**
CPC G02B 21/13; G02B 21/26; G02B 21/34; G01N 1/312; G01N 1/2813; G01N 35/028;
(Continued)

19 Claims, 19 Drawing Sheets

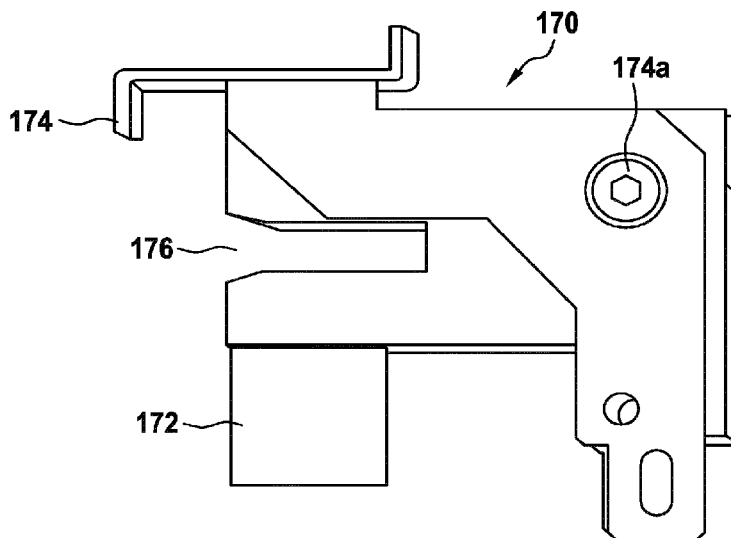

(58) **Field of Classification Search**
 CPC G01N 35/0029; G01N 2035/00138; B01L
 9/52; B01L 2300/0822; F16B 5/0635;
 F16B 5/0057; F16B 5/10; F16B 2/18
 See application file for complete search history.

2014/0071438 A1 3/2014 Gouch et al.
 2014/0362436 A1* 12/2014 Forget G02B 21/26
 359/391

FOREIGN PATENT DOCUMENTS

EP	0245089	11/1987
EP	00534247	2/2002
JP	S62269924 A	11/1987
JP	H09152556	6/1997
WO	2013017855	2/2013

(56) **References Cited**

U.S. PATENT DOCUMENTS

4,453,907 A *	6/1984	Taguchi	B29C 48/10 425/72.1
4,836,667 A *	6/1989	Ozeki	G02B 21/24 359/398
5,659,421 A *	8/1997	Rahmel	G02B 21/26 359/393
6,118,582 A *	9/2000	Del Buono	B01L 3/50855 359/398
6,522,774 B1	2/2003	Bacus et al.	
6,640,014 B1	10/2003	Price	
6,711,283 B1	3/2004	Soenksen	
7,485,834 B2	2/2009	Gouch	
7,682,573 B1 *	3/2010	DeBolt	G02B 21/34 422/534
8,712,116 B2	4/2014	Gouch	
9,116,035 B2	8/2015	Gouch	
11,231,574 B2	1/2022	Hawes et al.	

OTHER PUBLICATIONS

U.S. Appl. No. 16/477,834, Non-Final Office Action, dated Jun. 8, 2021, 10 pages.
 U.S. Appl. No. 16/477,834, Notice of Allowance, dated Sep. 29, 2021, 10 pages.
 U.S. Appl. No. 16/477,834, Notice of Allowance, dated Aug. 13, 2021, 8 pages.
 International Application No. PCT/EP2018/050567, International Preliminary Report on Patentability, dated Jul. 25, 2019, 7 pages.
 International Application No. PCT/EP2018/050567, International Search Report and Written Opinion, dated Mar. 29, 2018, 9 pages.
 European Application No. 23152724.3, "Extended European Search Report", dated Jun. 15, 2023, 6 pages.

* cited by examiner

Fig. 1(a)

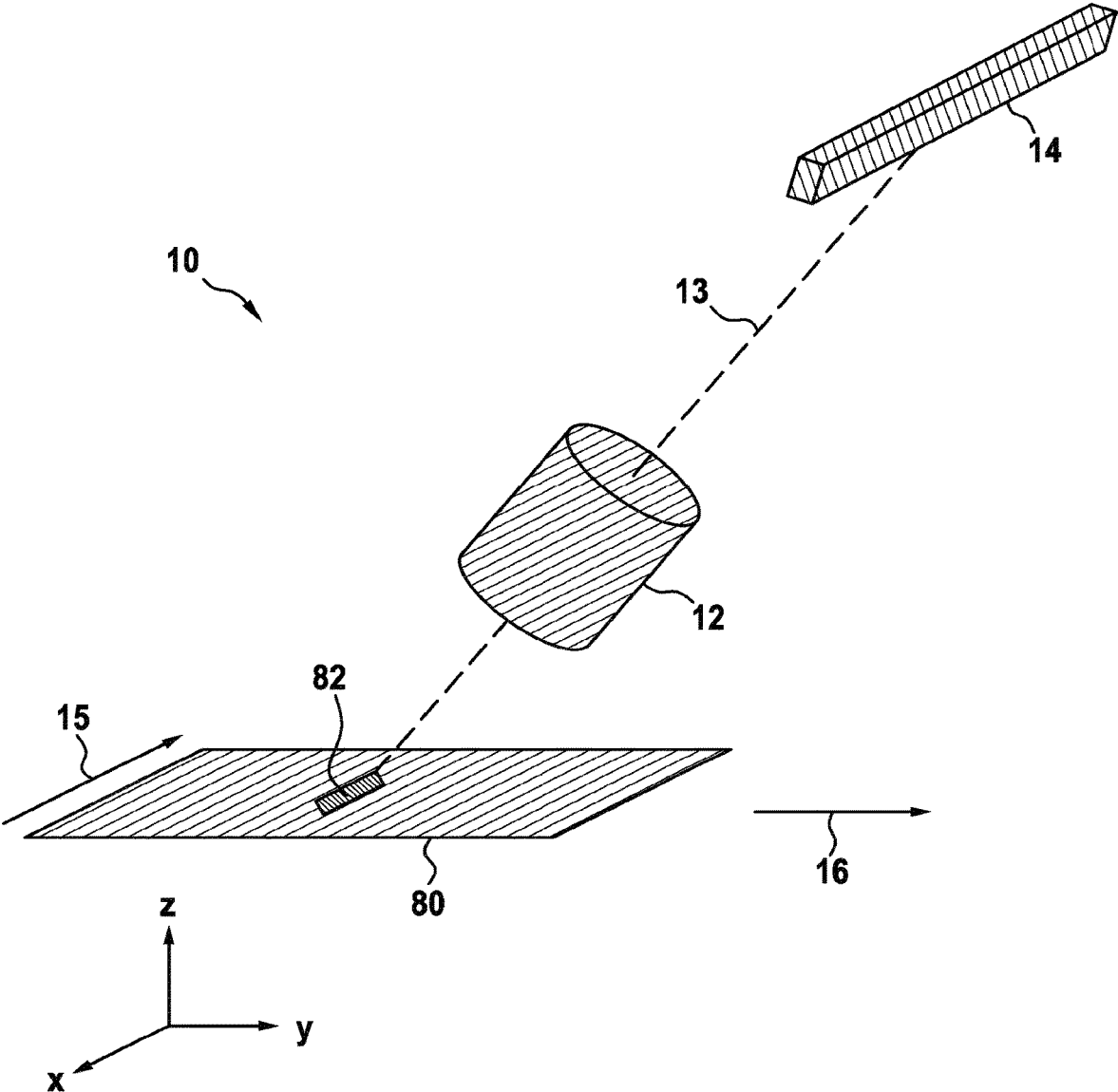

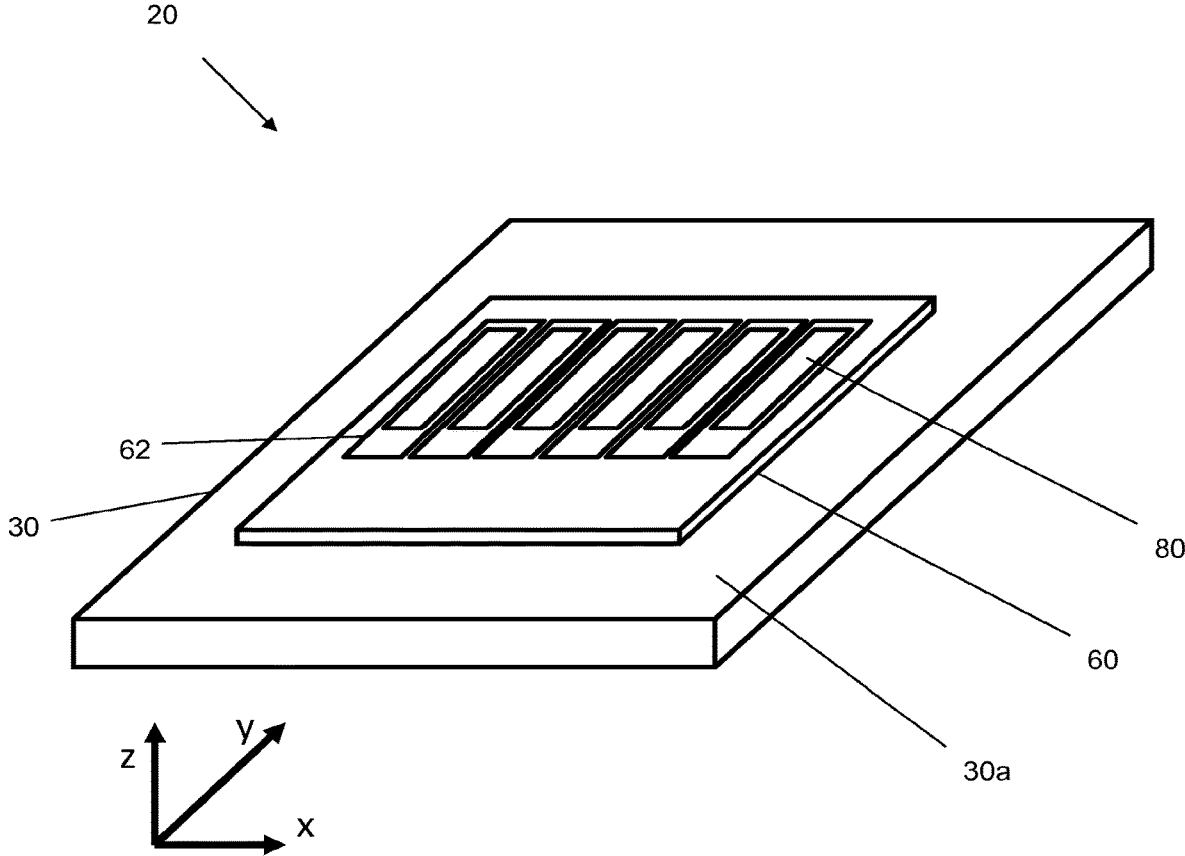

Figure 1(b)

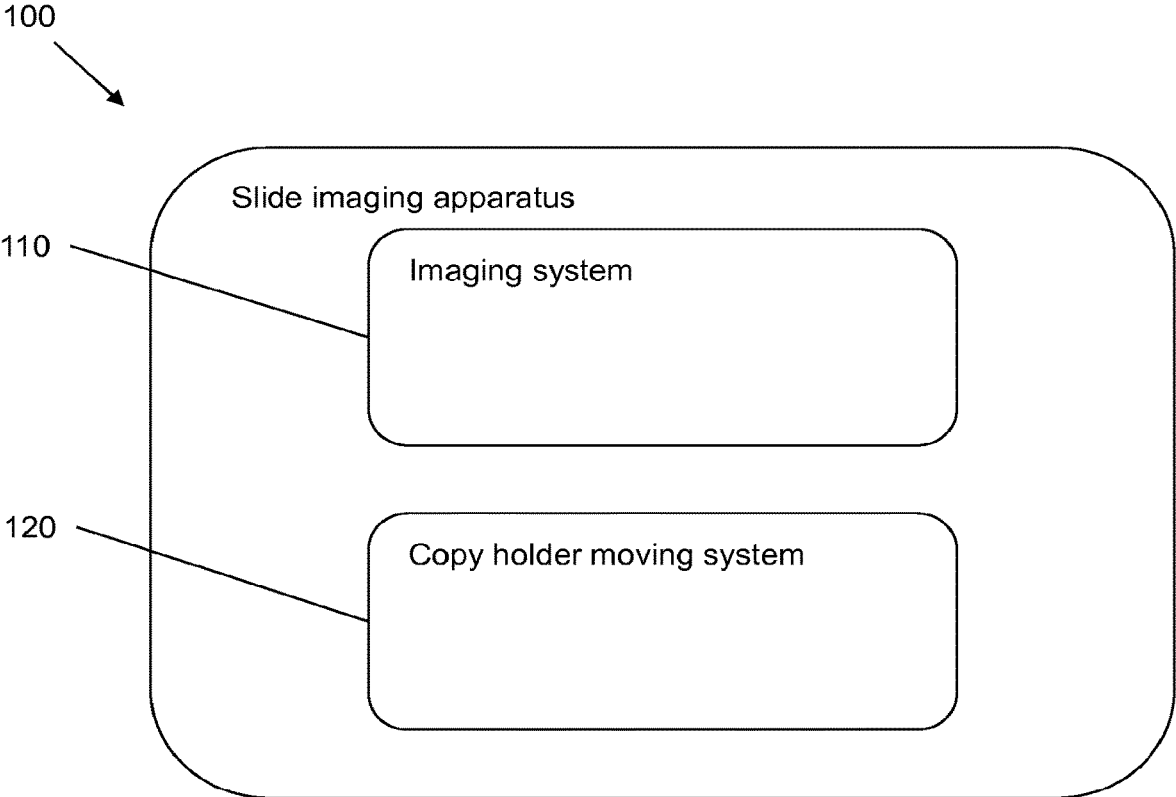

Figure 2

Fig. 3(a)

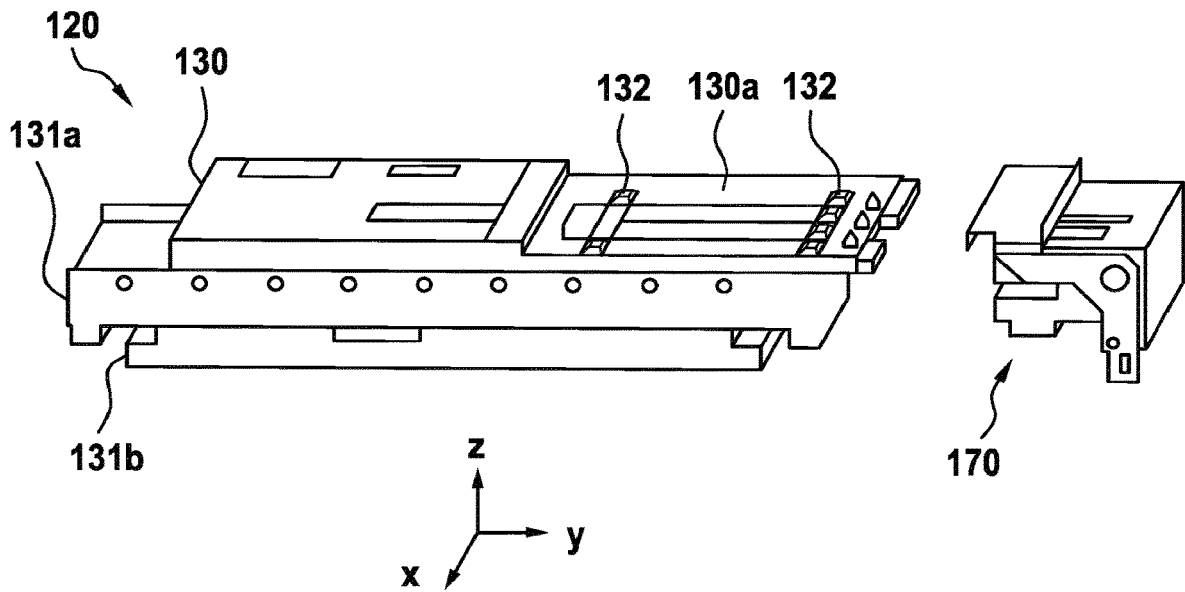

Fig. 3(b)

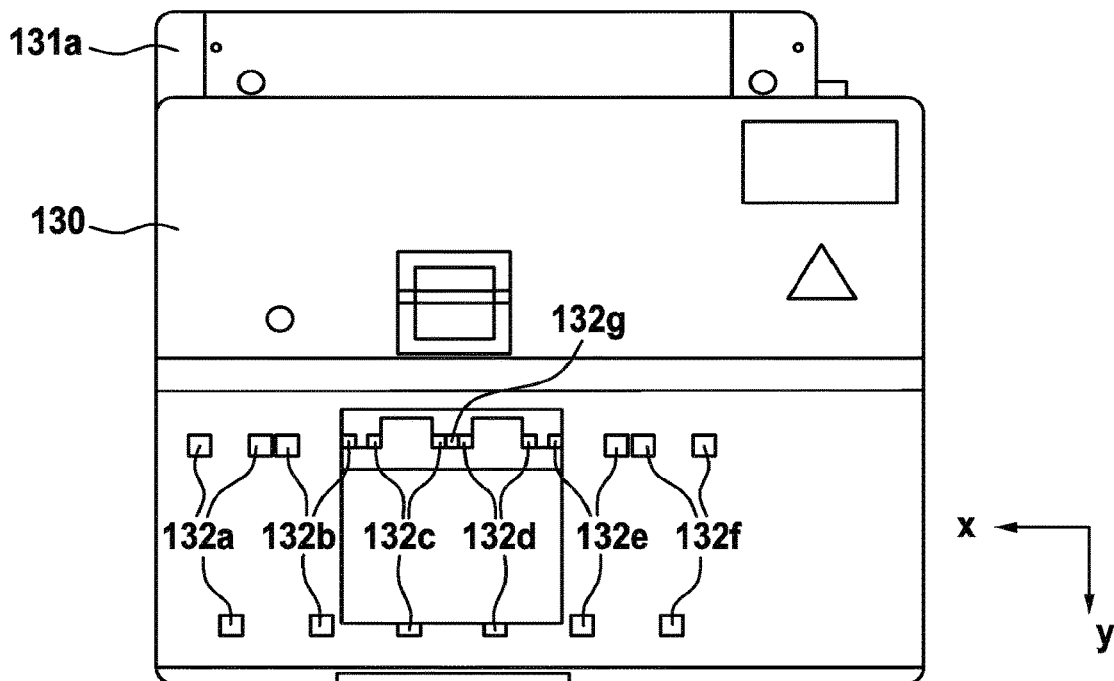

Fig. 3(c)

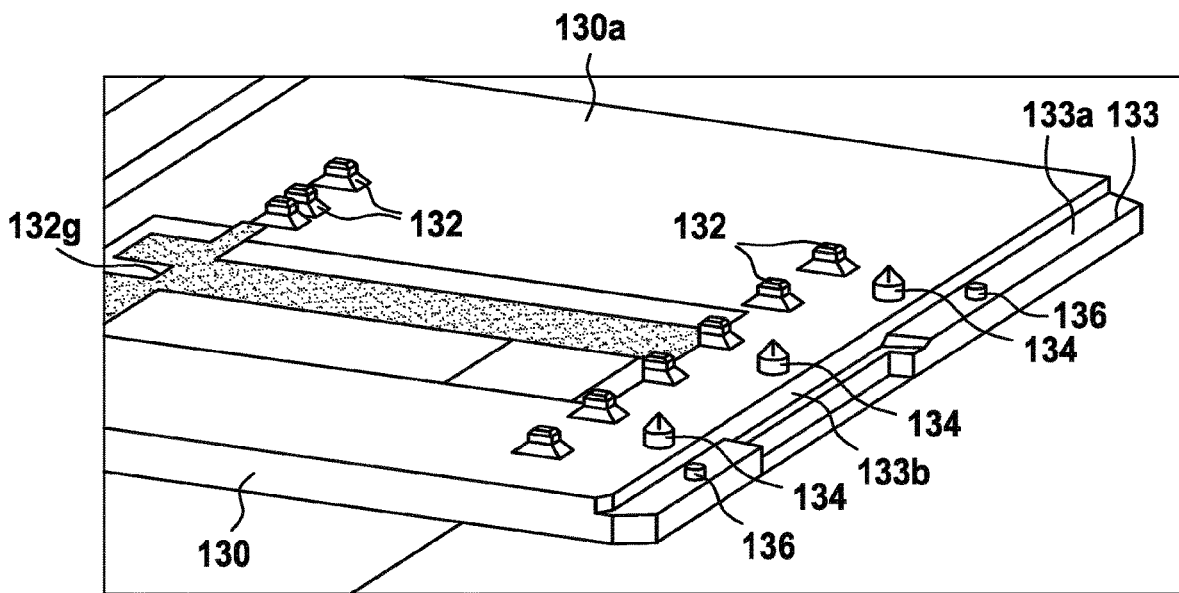

Fig. 3(d)

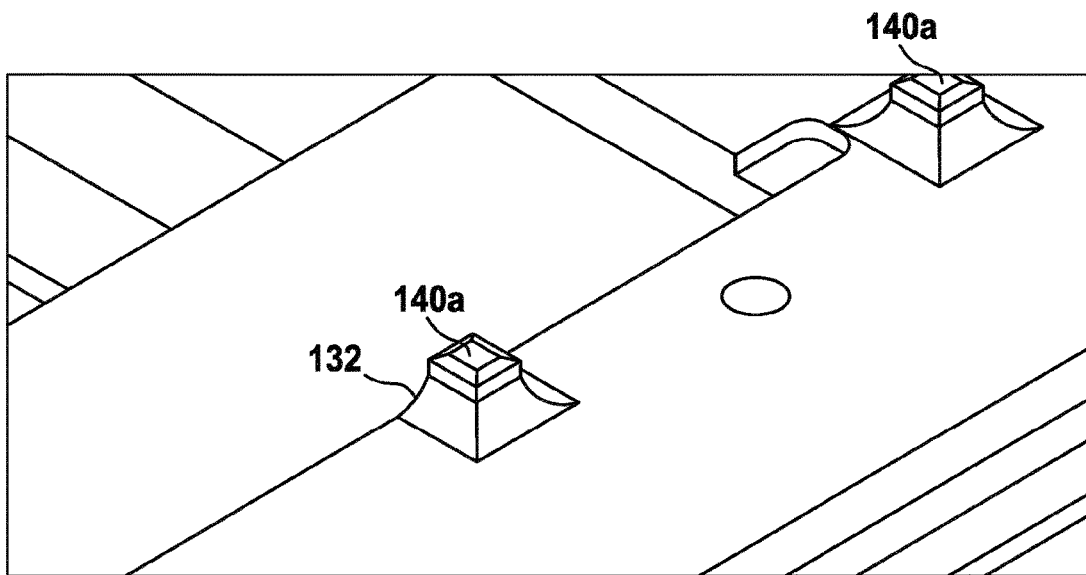

Fig. 3(e)

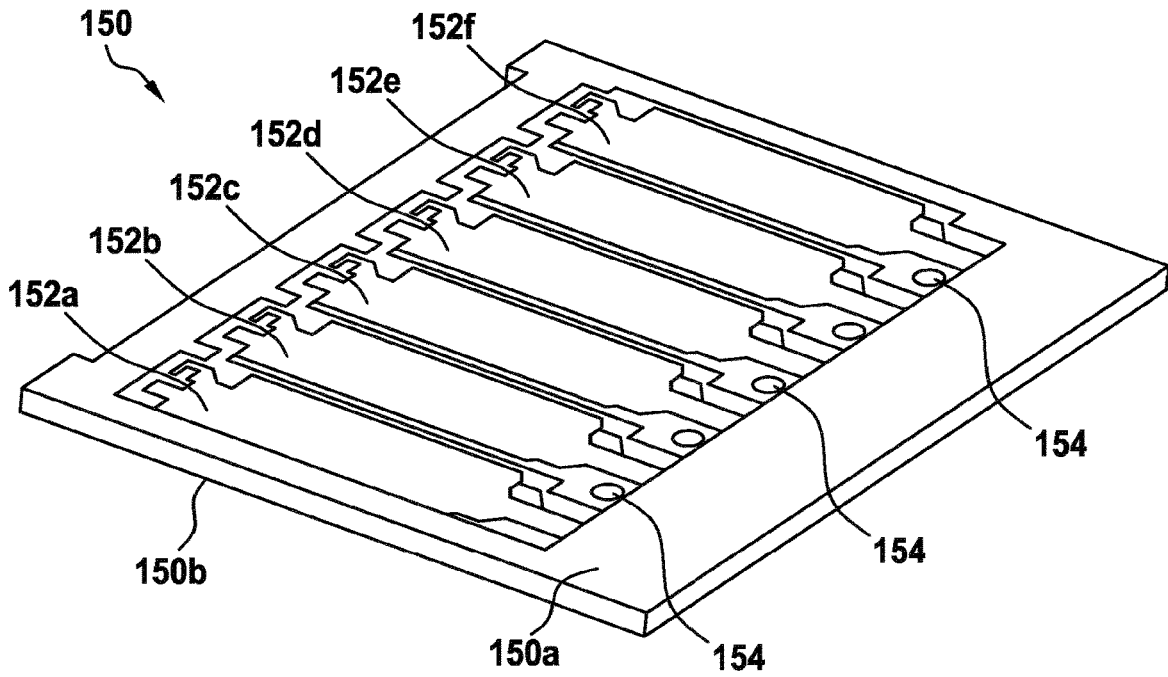

Fig. 3(f)

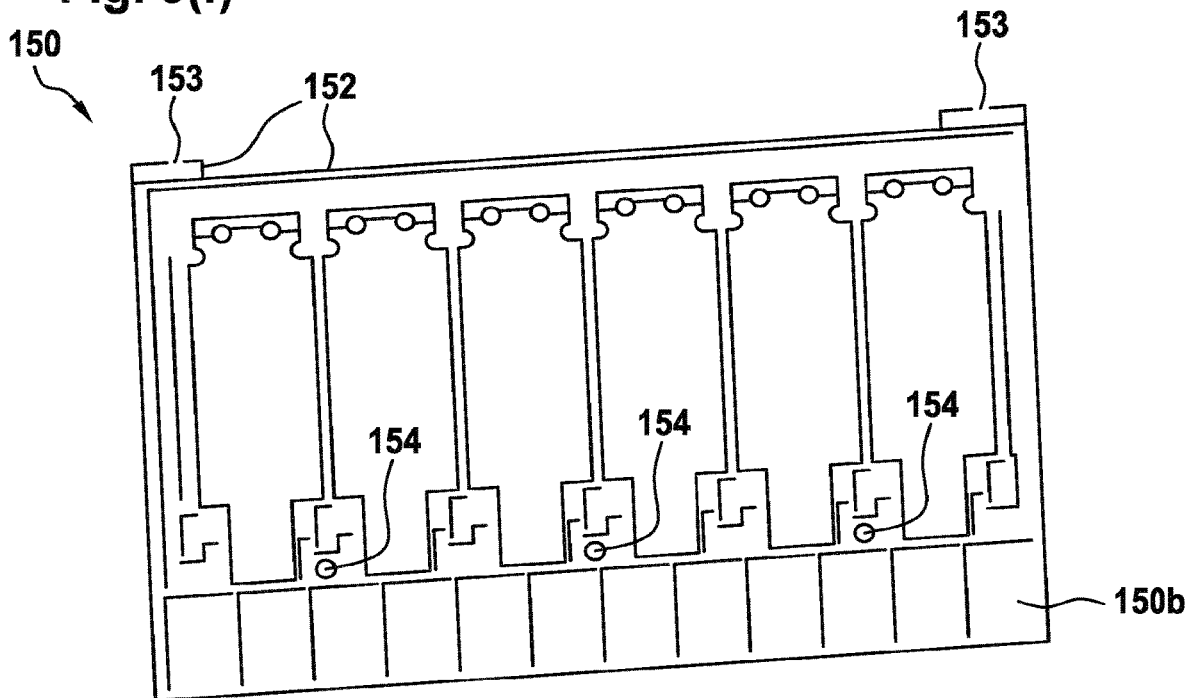

Fig. 3(g)

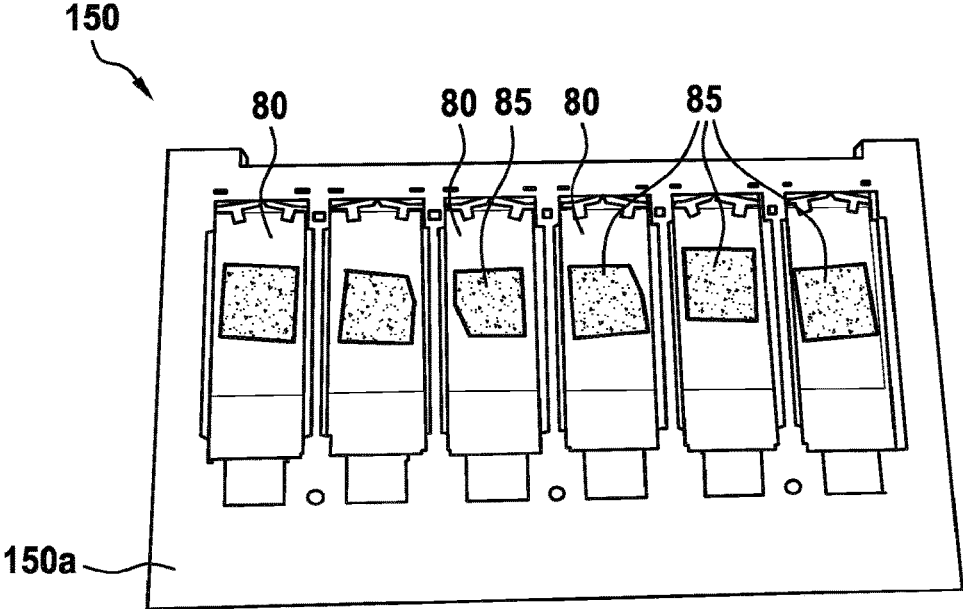

Fig. 3(h)

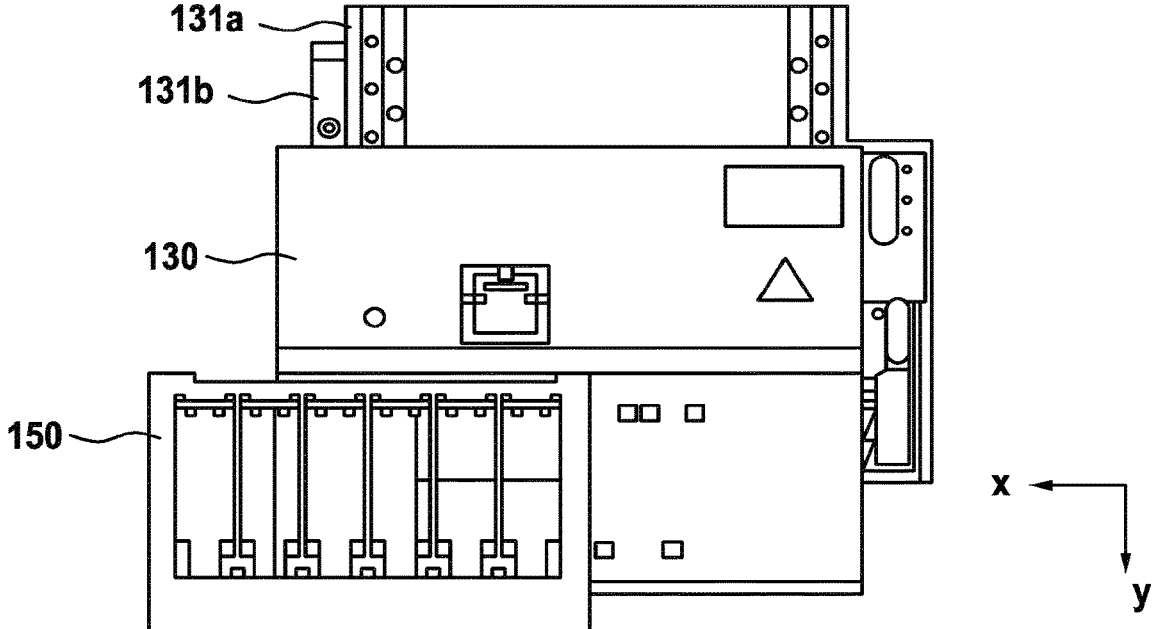

Fig. 4(a)

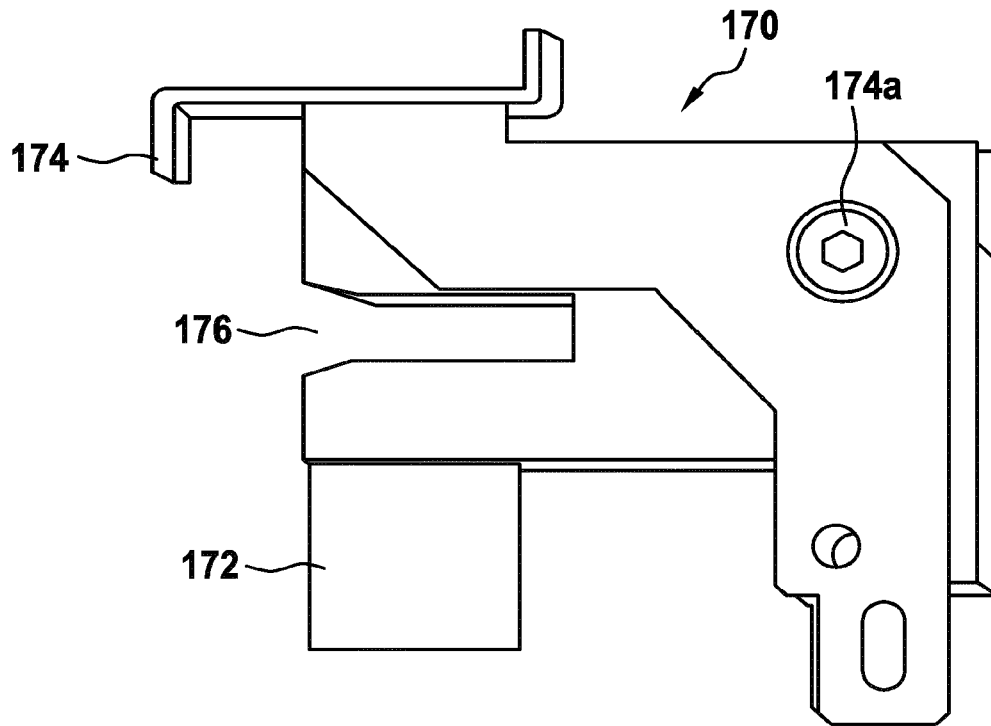

Fig. 4(b)

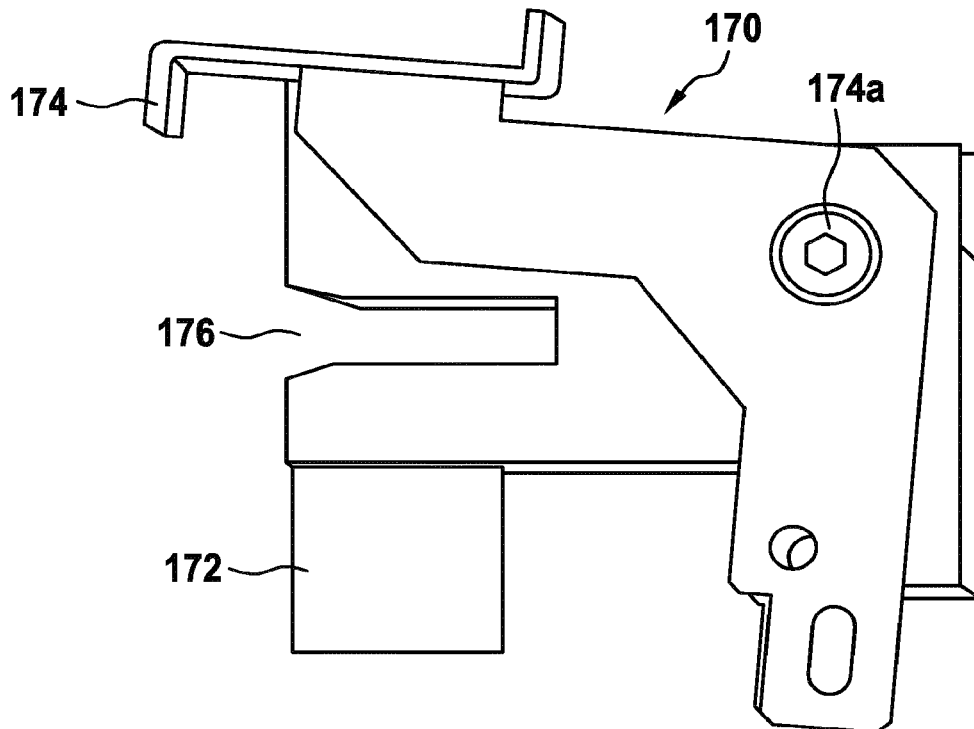
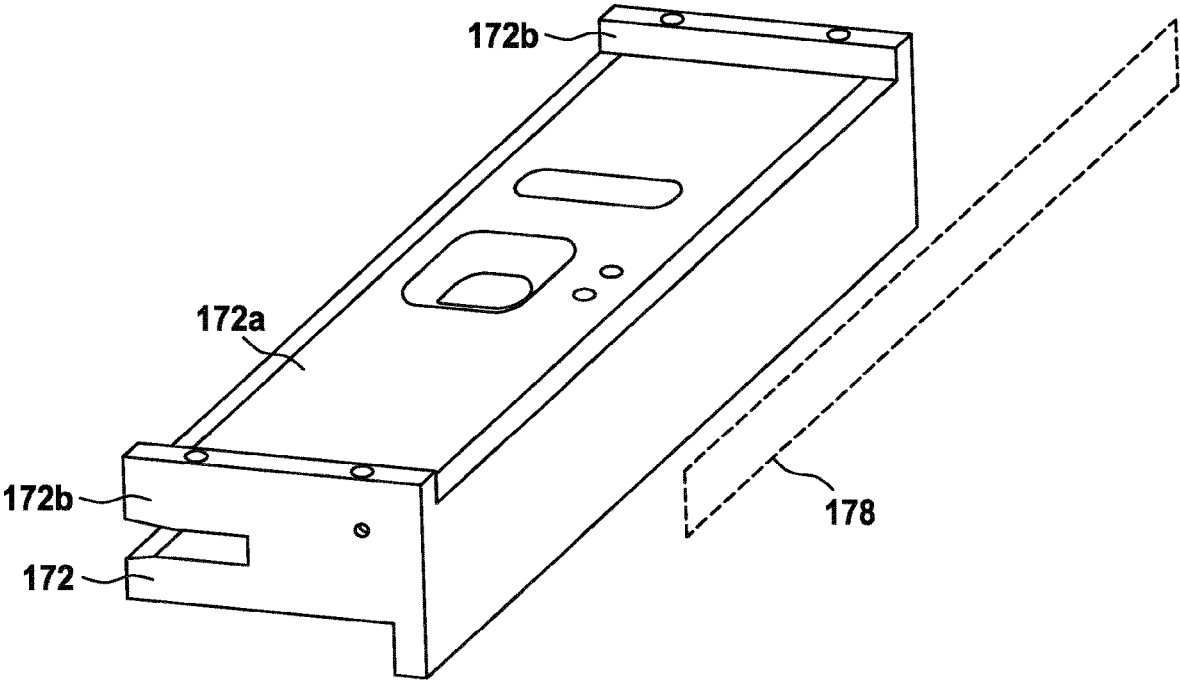

Fig. 4(c)



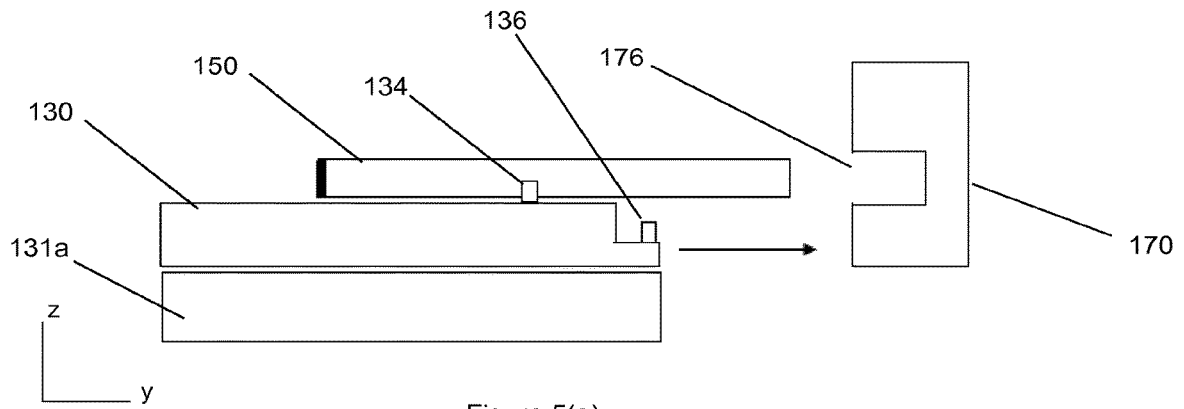

Figure 5(a)

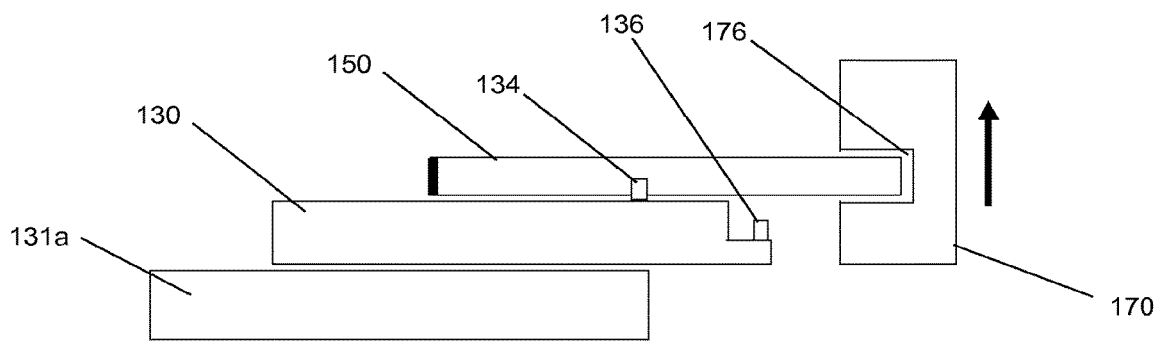

Figure 5(b)

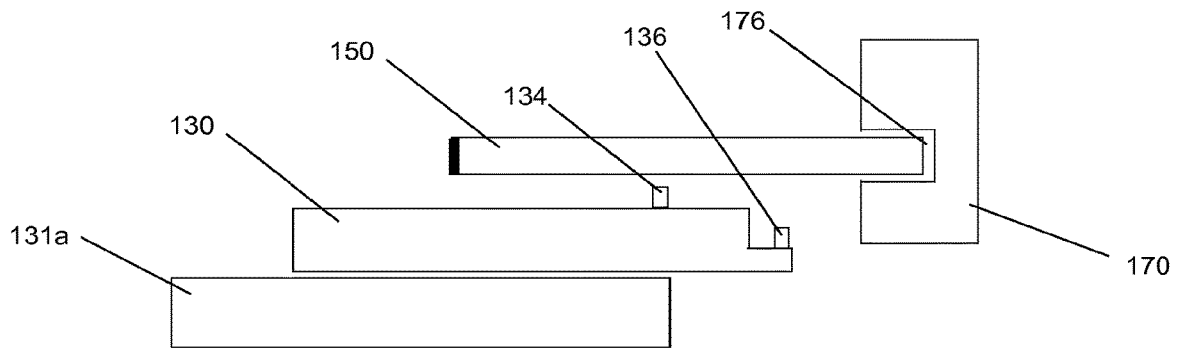

Figure 5(c)

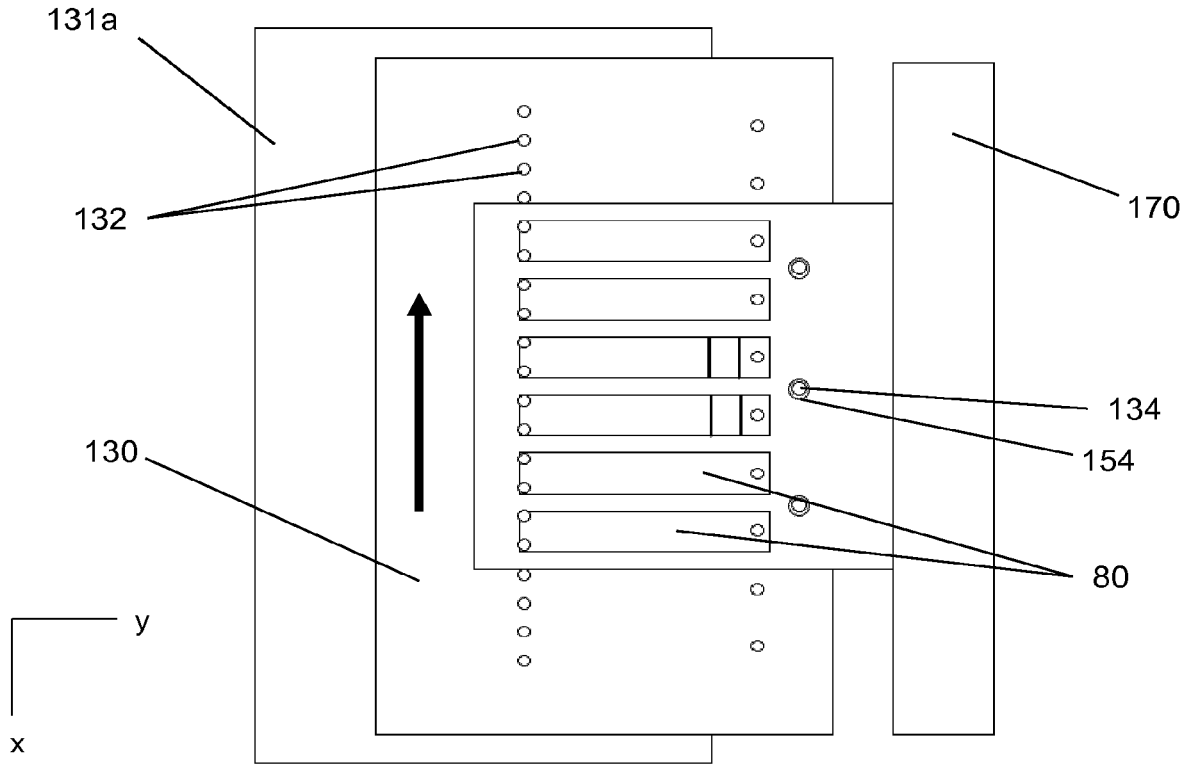

Figure 5(d)

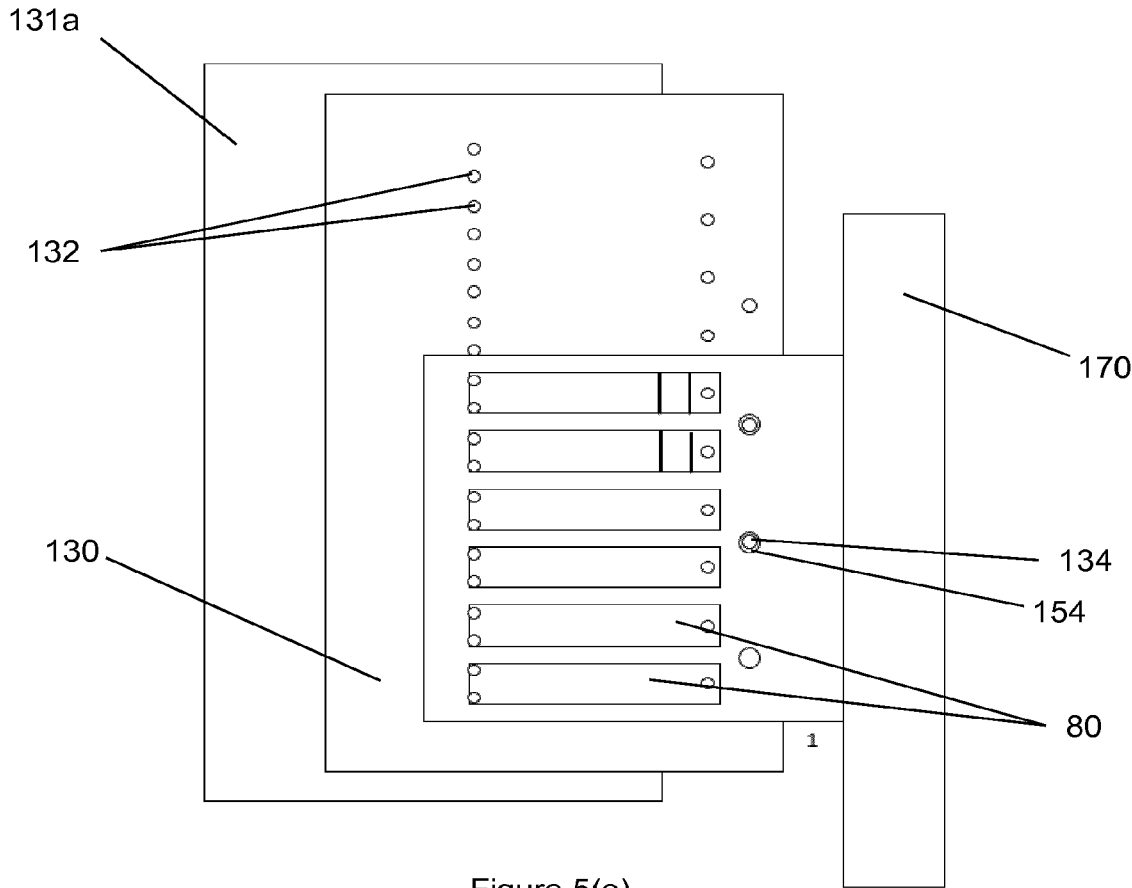

Figure 5(e)

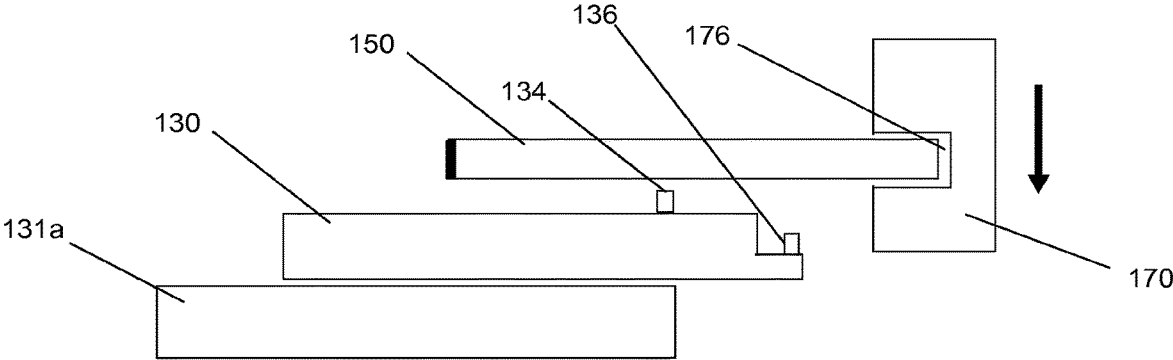

Figure 5(f)

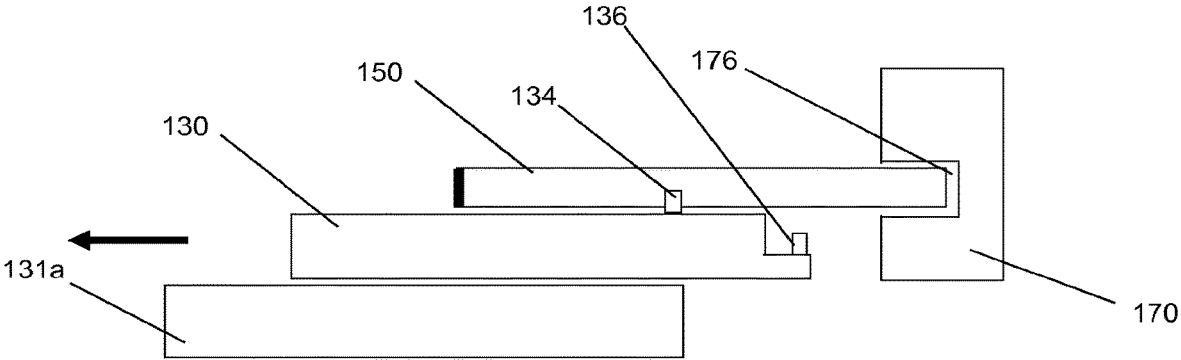

Figure 5(g)

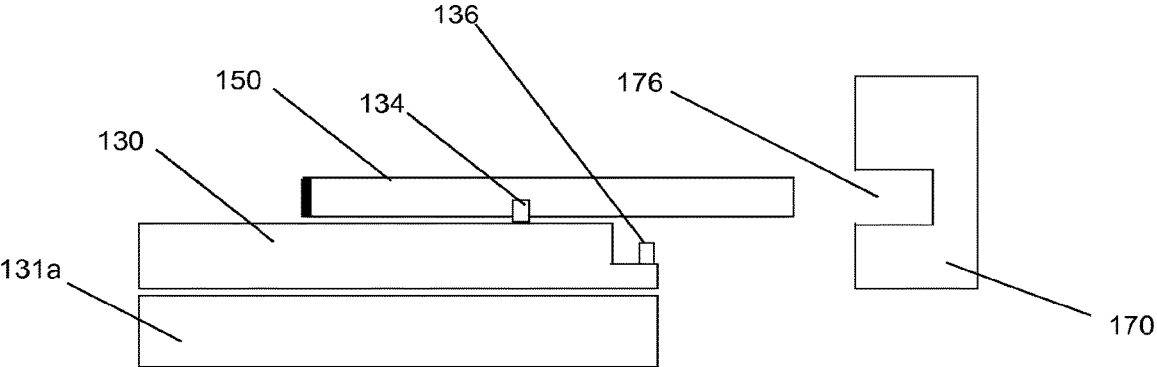

Figure 5(h)

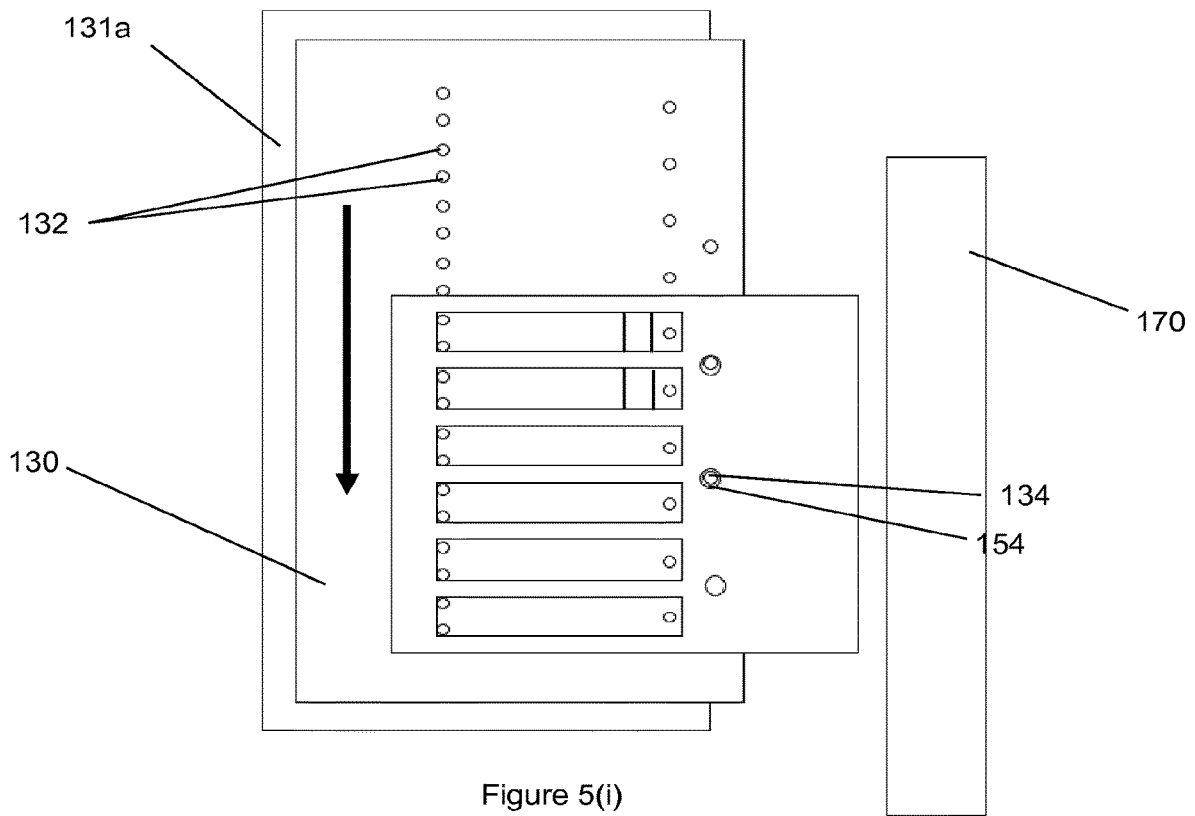

Figure 5(i)

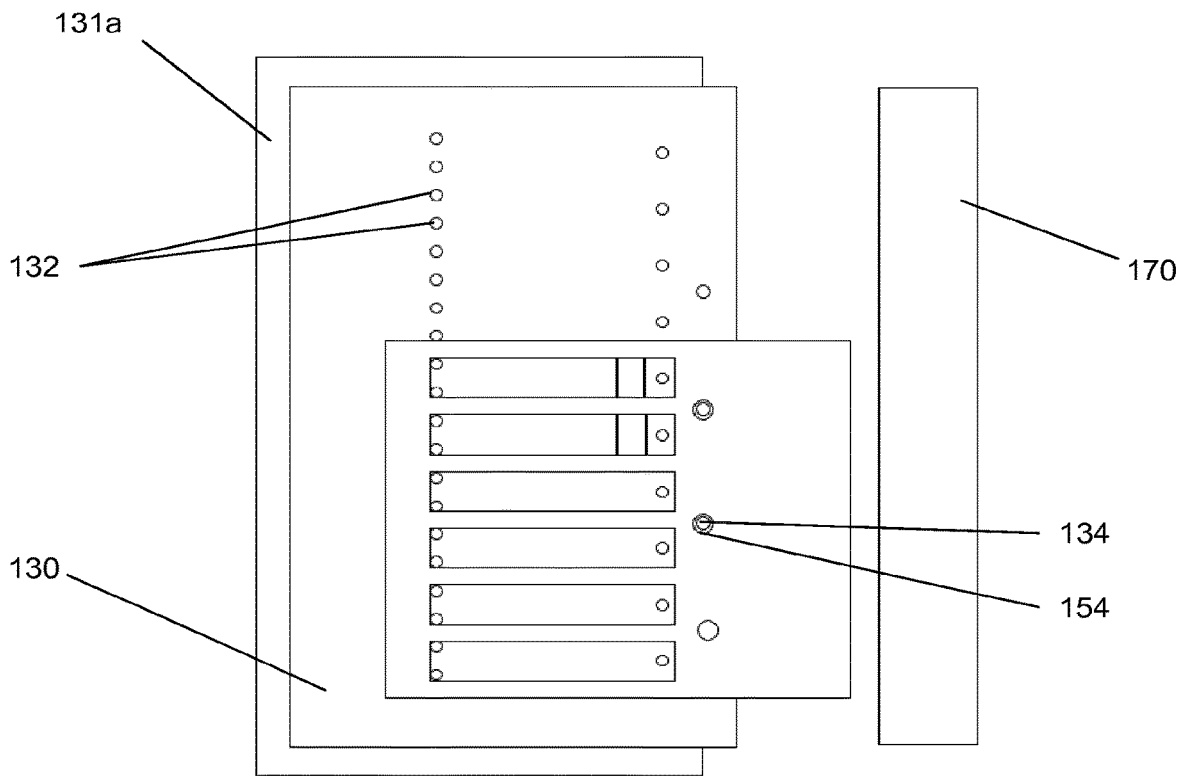
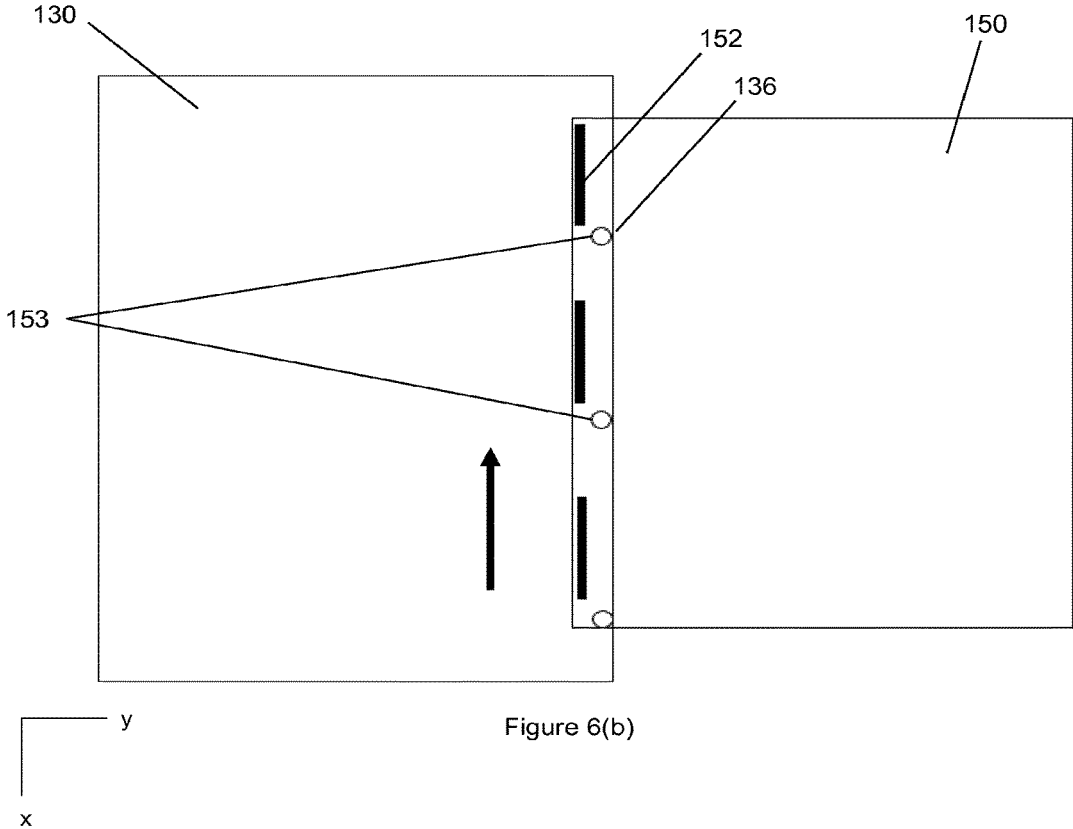
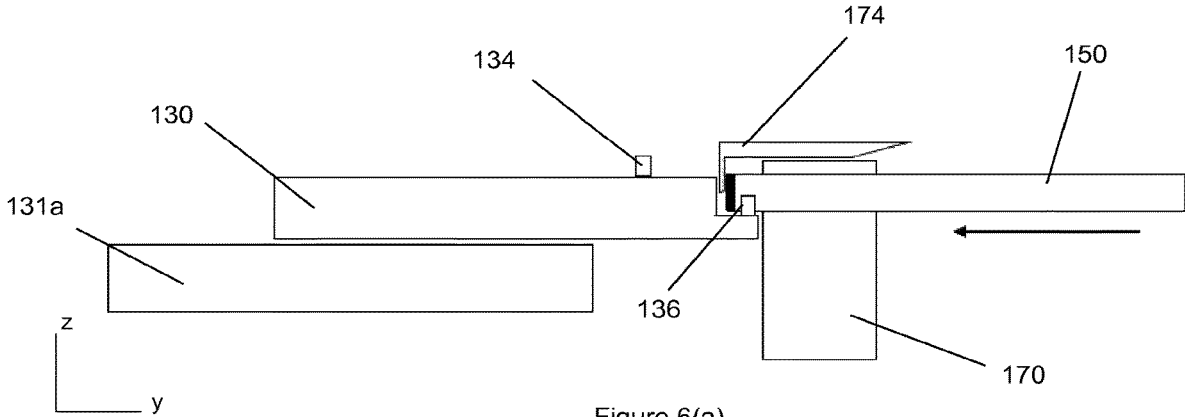

Figure 5(j)



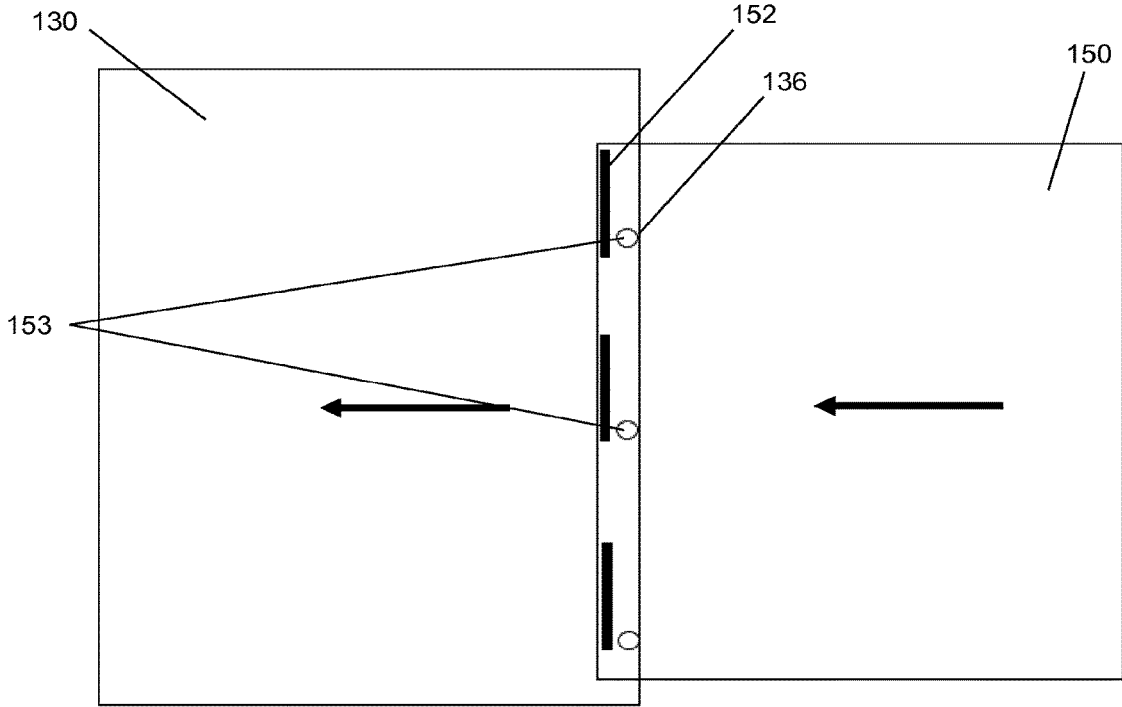

Figure 6(c)

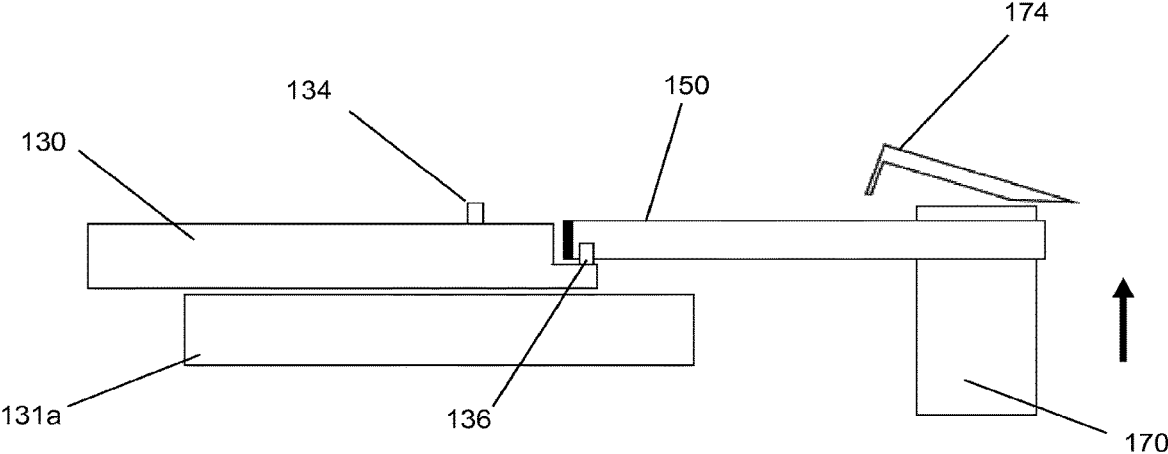

Figure 6(d)

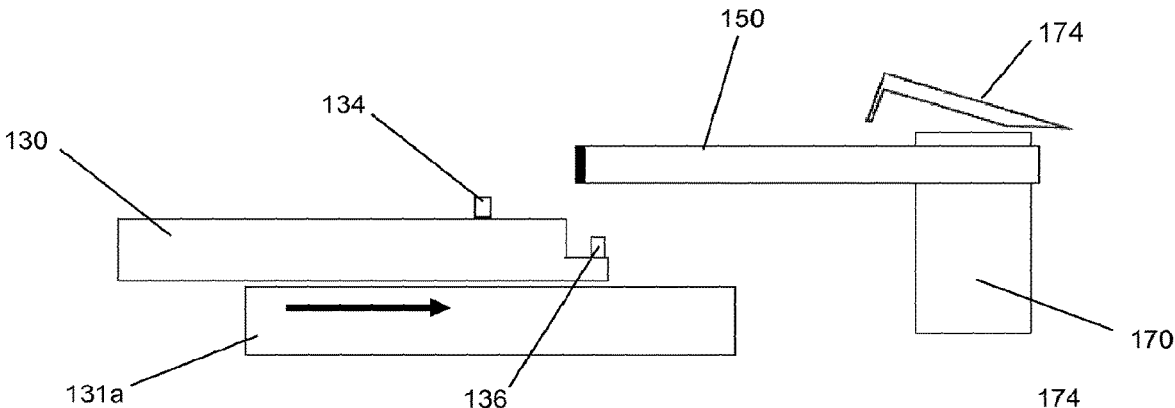

Figure 6(e)

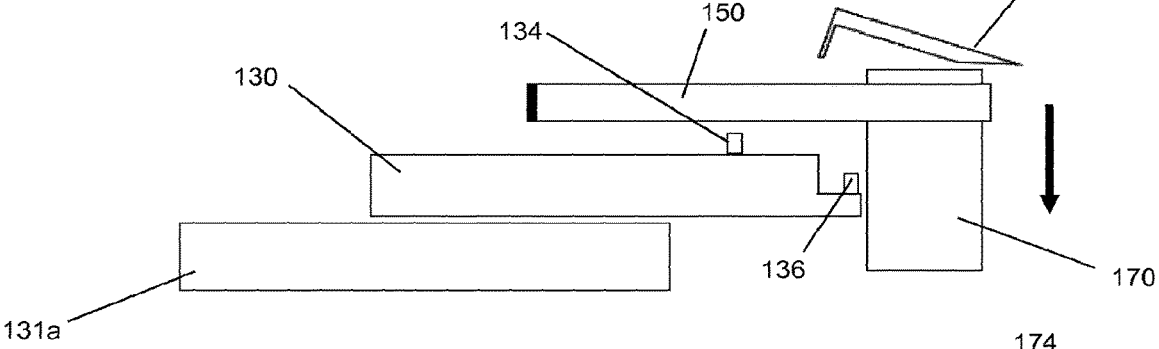

Figure 6(f)

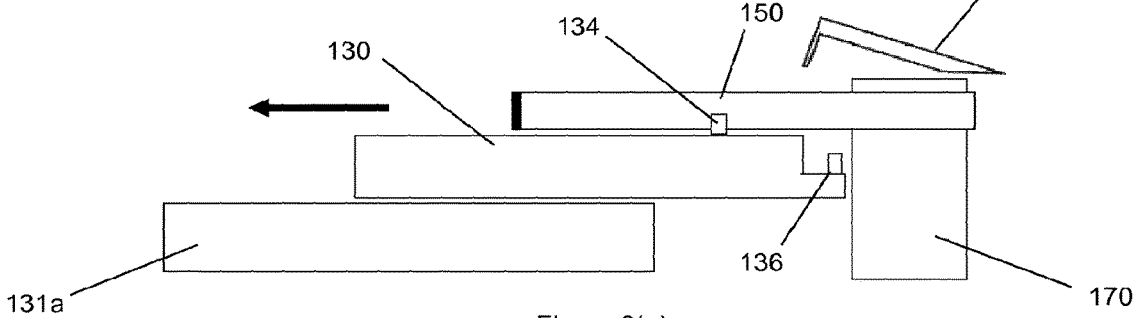

Figure 6(g)

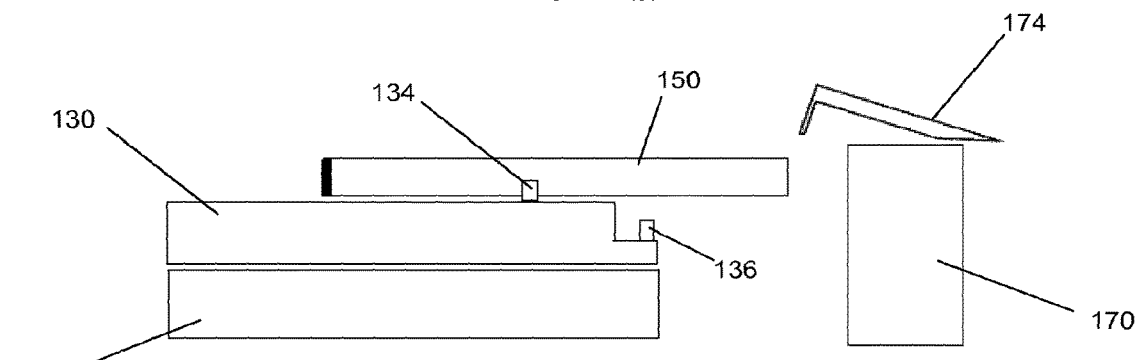
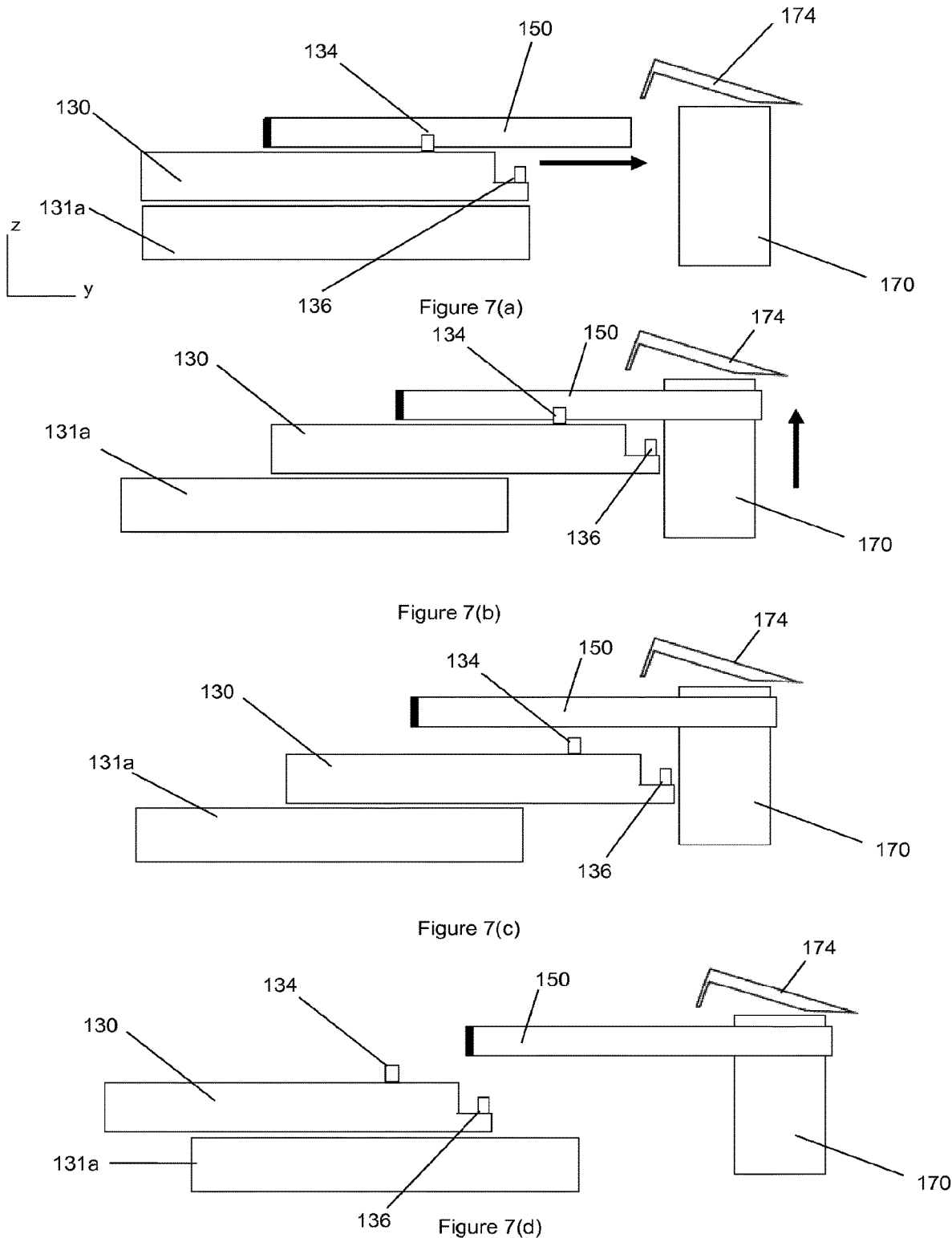

Figure 6(h)



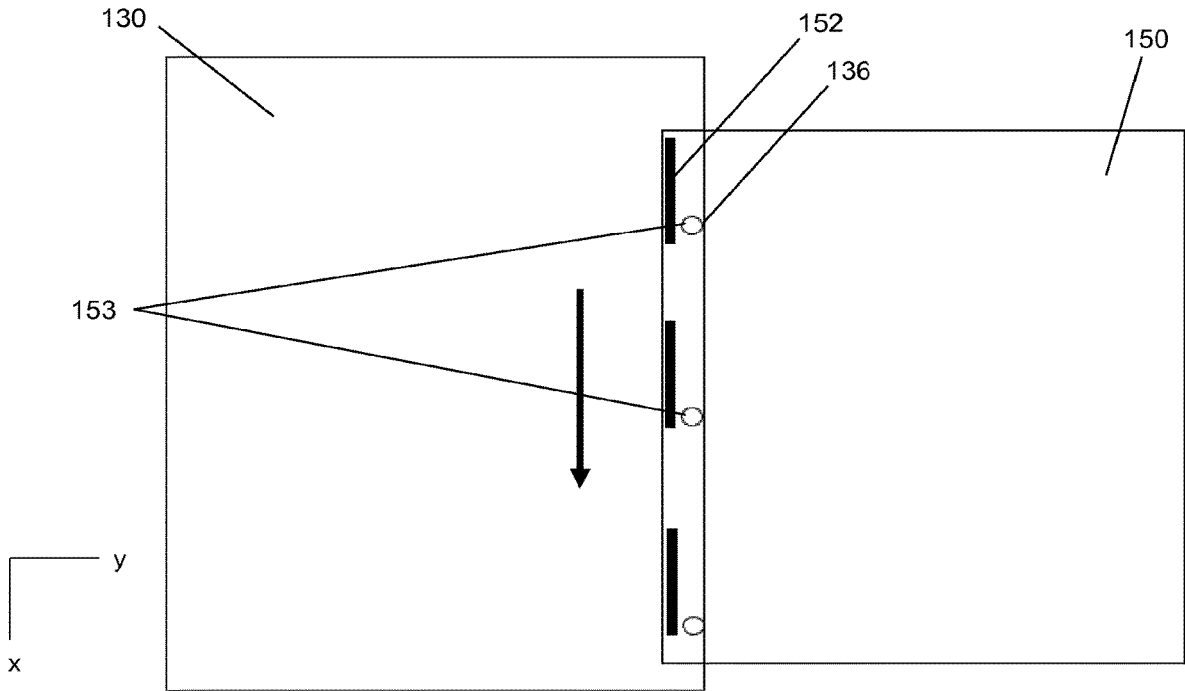

Figure 7(e)

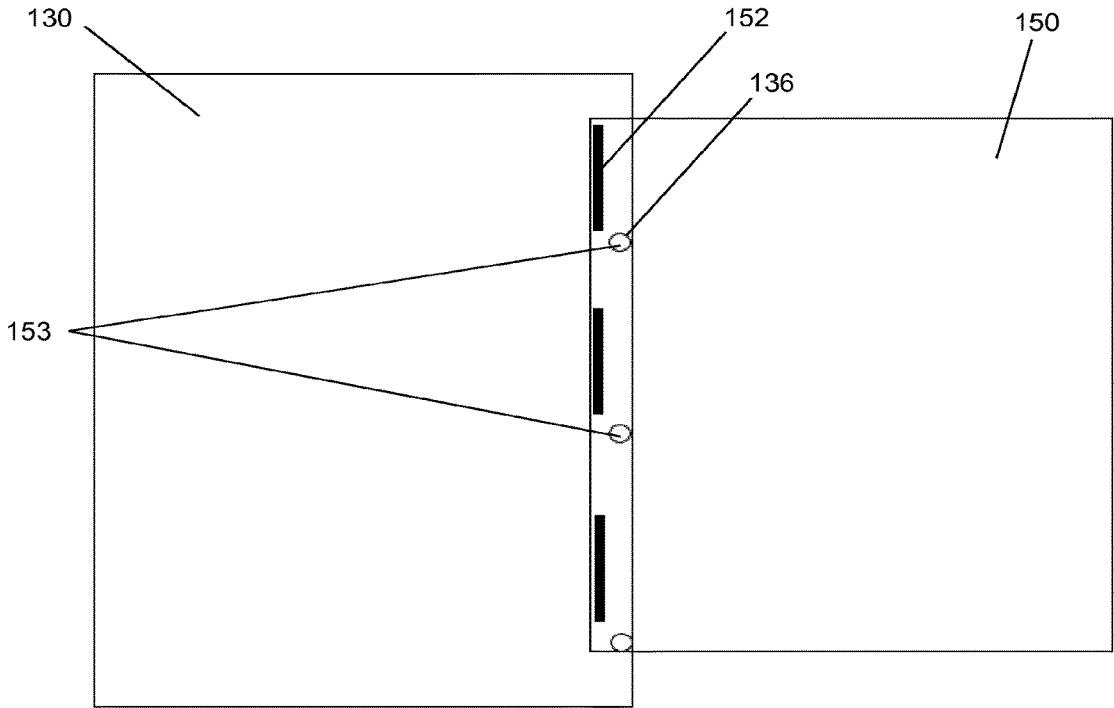
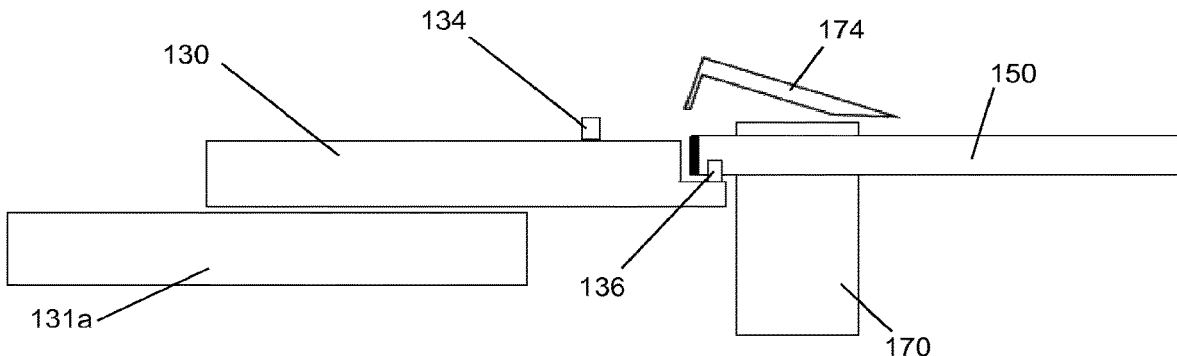
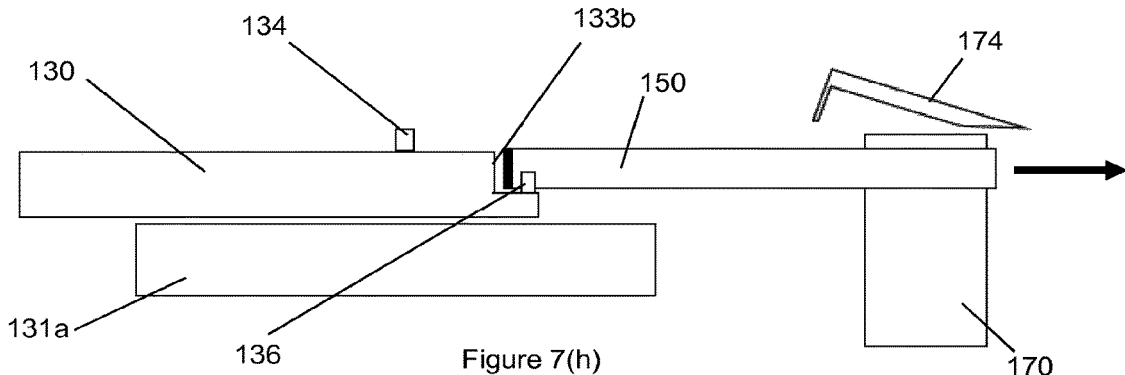
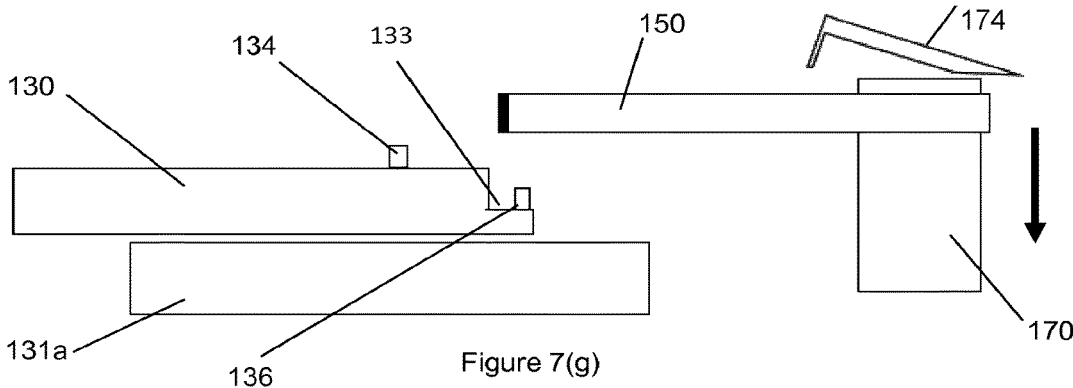

Figure 7(f)



SLIDE IMAGING APPARATUS

FIELD OF THE INVENTION

This invention relates to a slide imaging apparatus, e.g. 5
for use in digital pathology.

BACKGROUND

A slide imaging apparatus is an imaging apparatus con- 10
figured to form an image of a sample mounted on a slide.
The image formed by modern slide imaging apparatuses is
typically a digital image, and such an image may therefore
be referred to as a “digital slide”. Typically, the sample
mounted on the slide is a biological specimen, such as a 15
tissue sample. Typically the slide is a glass slide.

Typically, a slide imaging apparatus is used in digital
pathology, which can be understood as an image-based
information environment that allows for the management of
information generated from a digital slide 20

Where a slide imaging apparatus is capable of forming an
image covering the majority if not all the surface of a slide,
e.g. through a scanning process, the slide imaging apparatus
may be referred to as a “whole slide imaging” apparatus.

A slide imaging apparatus may use a 2D camera or a line 25
scan detector to form the image of a sample mounted on a
slide.

Examples of slide imaging apparatuses are described in
U.S. Pat. No. 6,522,774, EP00534247B1, U.S. Pat. No.
6,640,014B1, U.S. Pat. No. 6,711,283B1, U.S. Pat. No. 30
9,116,035, WO2013017855 and U.S. Pat. No. 8,712,116, for
example.

FIG. 1(a) shows an example imaging system 10 for use in
a slide imaging apparatus. The imaging system 10 of FIG.
1(a) includes a line scan detector 14 and operates according 35
to known principles.

In more detail, the imaging system 10 of FIG. 1(a)
includes an imaging lens 12 configured to focus light
originating from a sample mounted on a slide 80 onto the
line scan detector 14. The line scan detector 14 typically 40
includes a linear array of pixels.

In the imaging system 10, the line scan detector 14 is
configured to acquire 1D image data from an elongate region
82 of the sample that extends along a swathe width axis
(x-axis). The swathe width axis is perpendicular to a scan 45
length axis (y-axis).

FIG. 1(b) shows an example copy holder moving system
20 for use with the imaging system 10 of FIG. 1(a) in a slide
imaging apparatus.

The copy holder moving system 20 includes a movable 50
stage 30 and a copy holder 60. The movable stage 30 is
configured to be moved along the scan length axis (y-axis)
and the swathe width axis (x-axis). The copy holder 60 is
configured to be mounted to the movable stage 30. The copy
holder 60 includes a plurality of apertures in the form of 55
slots 62, each slot 62 being configured to loosely hold a
respective slide 80. A top surface 30a of the movable stage
30 includes a plurality of metal slide support pins (not shown
in FIG. 1(b)) located so that when the copy holder 60 is
mounted on the movable stage 30, the/each slide 80 loosely 60
held by a slot 62 on the copy holder 60 is supported by three
metal slide support pins.

It is preferred that top surfaces of the metal slide support
pins which contact the slides 80 are coplanar so that the
imaging system 10 is able to more easily retain focus of 65
samples mounted on the slides 80 supported by the slide
support pins whilst it is moved by the moveable stage 30.

In use, the copy holder 60 holding a plurality of slides 80
is mounted to the movable stage 30. The movable stage 30,
and therefore each slide 80 held by the copy holder 60
mounted to the movable stage 30, is moved along the scan
length axis (y-axis) and along the swathe width axis (x-axis)
so that the imaging system is able to form an image of a
sample mounted on each slide 80.

In more detail, the imaging system 10 is configured to
form an image of a respective sample mounted on each slide
80 in a plurality of swathes, wherein each swathe is formed
by a group of scan lines, each scan line being acquired using
the scan line detector 14 from a respective elongate region
82 on the surface of the sample that extends along the swathe
width axis, wherein each group of scan lines is acquired
whilst the slide 80 is moved relative to the scan line detector
14 along the scan length axis (y-axis), e.g. in the direction
labelled 16 in FIG. 1(a), using the copy holder moving
system 20. After one swathe has been acquired, the slide 80
is moved along the swathe width axis (x-axis), e.g. in the
direction labelled 15 in FIG. 1(a), to allow a further swathe
to be acquired by moving the slide 80 along the scan length
axis (y-axis). This further swathe may be acquired by
moving the slide 80 along the scan length axis in a direction
opposite to the direction labelled 16 in FIG. 1(a), e.g. such
that the slide 80 is moved along a serpentine path during the
image forming process.

Typically, an individual swathe acquired from a sample
mounted on a slide 80 may, at the surface of the slide 80, e.g.
be approximately 1 mm wide along the swathe width axis
(x-axis) and between 2 mm and 60 mm long along the scan
length direction (y-axis). Multiple swathes can be combined
to generate an image wider than the (e.g. approximately 1
mm) width of an individual swathe.

A focus setting of the imaging system 10 of FIG. 1(a) may
be adjusted, for example, by moving the imaging lens 12
along an imaging axis 13. Imperfections in the slide support
pins, imperfections in a slide 80 resting on the slide support
pins, or an uneven sample mounted on the slide 80, can
cause loss of focus whilst a digital image of the sample is
being acquired. Therefore, during the acquisition of a
swathe, a focus setting of the imaging system 10 can be
dynamically adjusted to maintain the sample in focus along
the length of the sample along the scan length axis (y-axis).
Techniques suitable for measuring and dynamically adjust-
ing a focus setting of the imaging system 10 to maintain the
sample in focus along the length of the sample as the slide
80 is moved along the scan length axis are described in the
literature, see e.g. U.S. Pat. No. 7,485,834, WO2013/017855
and US2014/0071438.

An example slide imaging apparatus implementing the
principles described above with reference to FIG. 1(a) and
FIG. 1(b) is the SCN400 slide scanner marketed by Leica™.
A video describing the operation of the SCN400 slide
scanner can be found at [https://www.youtube.com/
watch?v=hrUI8HU8xE](https://www.youtube.com/watch?v=hrUI8HU8xE).

The present inventors have observed some challenges
with a slide imaging apparatus implementing the principles
described above with reference to FIG. 1(a) and FIG. 1(b).

For example, the present inventors have observed that the
more slides 80 that can be held by the copy holder 60, the
wider the slide imaging apparatus needs to be in order to
allow the copy holder 60 to be moved into a position where
an image of a sample mounted on each slide 80 can be
formed by the imaging system 10. For example, a copy
holder 60 that holds six slides generally requires a wider

slide imaging apparatus in order to accommodate movement of the copy holder, compared with a copy holder that holds only two slides.

The present inventors have also observed that the copy holder 60 is typically manually mounted onto the movable stage 30. This job can be fiddly as the slides 80 may be loosely held by the copy holder 60 and so can fall out, and a user's hand may damage one or more components of the slide imaging apparatus during the copy holder mounting process.

The present invention has been devised in light of the above considerations.

SUMMARY OF THE INVENTION

A first aspect of the invention may provide a slide imaging apparatus that includes:

- a copy holder moving system; and
- an imaging system;

wherein the copy holder moving system includes:

- a movable stage configured to move along first and second slide movement axes relative to the imaging system, wherein a top surface of the movable stage includes a plurality of slide support pins configured to support one or more slides in one or more imaging locations on the movable stage, wherein the imaging system is configured to form an image of a sample mounted on a slide located in the/each imaging location on the movable stage during an image forming process that includes the movable stage moving relative to the imaging system along the first and second slide movement axes;

- a copy holder configured to be mounted to the movable stage, wherein the copy holder includes a plurality of apertures, each aperture being configured to hold a respective slide;

wherein the copy holder is configured to be mounted to the movable stage in each of a plurality of indexing positions that include:

- a first indexing position in which a first subset of the slides held by the copy holder are supported in the one or more imaging locations by the slide support pins;

- a second indexing position in which a second subset of the slides held by the copy holder are supported in the one or more imaging locations by the slide support pins.

In this way, different subsets of the slides held by the copy holder can be located in the imaging location(s) at different times, by moving the copy holder between indexing positions. This may allow for all slides held by a copy holder to be imaged, even if the number of slides held by the copy holder is larger than the number of imaging locations. Having a smaller number of imaging locations is useful, since it allows for a more compact imaging apparatus, since a smaller range of movement of the movable platform can be needed to allow the imaging system to form an image of the/each slide located in the/each imaging location.

It follows from the above discussion that the number of apertures for holding slides in the copy holder may be larger than the number of imaging locations on the movable stage.

The terms "copy holder", "holder" and "slide holder" may be used interchangeably herein. Thus, instances of the term "copy holder" may be replaced with "holder" or "slide holder" herein.

The first and second slide movement axes should be non-parallel, and may be perpendicular with respect to each

other. For avoidance of any doubt, during the image forming process, the movable stage may move relative to the imaging system along the first slide movement axis at different times from when it moves along the second slide movement axis. It would also be possible for the movable stage to be moved along both the first and second slide movement axes at the same time.

The first and second slide movement axes are preferably parallel to an imaging plane of the imaging system. An imaging plane of the imaging system may be defined as a plane from which an image acquired by the imaging system is deemed to be in focus. Such a plane can usually be defined for any imaging system.

The copy holder and the movable stage may each have one or more indexing formations, which may be configured to cooperate with each other (e.g. one or more indexing formations on the copy holder may be configured to cooperate with one or more indexing formations on the movable stage) so as to act to fix the position of the copy holder relative to the movable stage when the copy holder is mounted to the movable stage in each indexing position.

The one or more indexing formations may include, for example, one or more pins formed on the movable stage and one or more corresponding holes formed in the copy holder, or one or more pins formed on the copy holder and one or more corresponding holes formed in the movable stage.

The number of indexing positions may be equal to the number of apertures for holding slides in the copy holder divided by the number of imaging locations on the movable stage. The number of slides in each subset of slides may be equal to the number of imaging locations on the movable stage.

The copy holder moving system may include a first motor configured to move the movable stage along the first slide movement axis and a second motor configured to move the movable stage along the second slide movement axis.

The copy holder moving system is preferably configured to perform an indexing process in which the copy holder is moved from one of the indexing positions to another of the indexing positions.

The copy holder moving system may include an indexing arm for holding the copy holder, and an indexing motor configured to move the indexing arm along an indexing axis that is non-parallel with respect to both the first and second slide movement axes.

The indexing process in which the copy holder is moved from one of the indexing positions to another of the indexing positions may include the indexing arm being moved by the indexing motor along the indexing axis as well as the movable stage being moved along the first and second slide movement axes by the first and second motors.

The indexing axis may be perpendicular to both the first and second slide movement axes. The first and second slide movement axes may be perpendicular to each other.

The copy holder moving system is preferably configured to perform a copy holder loading process in which the copy holder is moved from a predetermined copy holder loading location to be mounted on the movable stage in one of the indexing positions.

The copy holder loading process in which the copy holder is moved from a predetermined copy holder loading location to be mounted on the movable stage in one of the indexing positions may include the indexing arm being moved by the indexing motor along the indexing axis as well as the movable stage being moved by the first and/or second motors along the first and/or second slide movement axes.

In this way, the copy holder loading process can be performed using the same three motors that can be used to perform the above-described indexing process.

The copy holder and the movable stage may each have one or more engagement formations, which may be configured to engage with each other (e.g. one or more engagement formations on the copy holder may be configured to cooperate with one or more engagement formations on the movable stage) so that the movable stage is able to pull the copy holder away from the predetermined copy holder loading location during the copy holder loading process.

The engagement formations may include, for example, one or more pins formed on the movable stage and a lip located on a bottom surface of the copy holder.

The slide imaging apparatus may include a housing. The housing may house both the imaging system and the copy holder moving system.

The housing may include a slot, wherein the copy holder is configured to be put in the predetermined copy holder loading location by pushing it at least partially into the slot.

The copy holder moving system may include a stopping element for stopping the copy holder from being pushed past the predetermined copy holder loading location when it is pushed into the slot. The stopping element may be mounted on (e.g. a main body of) the indexing arm.

The copy holder moving system may include one or more copy holder guide surfaces for guiding the copy holder whilst it is pushed into and/or pulled out from the slot. The copy holder guide surfaces may be formed on the indexing arm. The copy holder guide surfaces may include a landing area for the copy holder to rest on.

The copy holder moving system is preferably configured to perform a copy holder unloading process in which the copy holder is moved from being mounted on the movable stage in one of the indexing positions to a predetermined copy holder unloading location.

The copy holder unloading process in which the copy holder is moved from being mounted on the movable stage in one of the indexing positions to a predetermined copy holder unloading location may include the indexing arm being moved by the indexing motor along the indexing axis as well as the movable stage being moved by the first and/or second motors along the first and/or second slide movement axes.

In this way, the copy holder unloading process can be performed using the same three motors that can be used to perform the above-described indexing process.

The movable stage may have a push surface configured to face the copy holder so that the push surface is able to push the copy holder towards the predetermined copy holder unloading location during the copy holder unloading process.

The copy holder unloading process in which the copy holder is moved from being mounted on the movable stage in one of the indexing positions to a predetermined copy holder unloading location may include the push surface pushing the copy holder at least partially out through the slot.

A second aspect of the invention may provide a slide imaging apparatus according to the first aspect of the invention, wherein the copy holder is omitted.

The invention also includes any combination of the aspects and preferred features described except where such a combination is clearly impermissible or expressly avoided.

For avoidance of any doubt, the use of the adjectives “top” and “bottom” in connection with an object may reflect an intended/preferred orientation when the object is used in

a slide imaging apparatus, and should not be interpreted to require a specific orientation of that object at all times, unless this is explicitly stated. The adjectives “top” and “bottom” may therefore be replaced with the terms “first” and “second”.

BRIEF DESCRIPTION OF THE DRAWINGS

Examples of these proposals are discussed below, with reference to the accompanying drawings in which:

FIG. 1(a) shows an example imaging system for use in a slide imaging apparatus.

FIG. 1(b) shows an example copy holder moving system for use with the imaging system of FIG. 1(a) in a slide imaging apparatus.

FIG. 2. shows an example slide imaging apparatus that includes an imaging system and a copy holder moving system.

FIGS. 3(a)-(h) show the copy holder moving system of FIG. 2 in more detail.

FIGS. 4(a)-(c) show an indexing arm belonging to the copy holder moving system of FIGS. 3(a)-(h) in more detail.

FIGS. 5(a)-(j) show an example indexing process performed by the copy holder moving system of FIGS. 3(a)-(h).

FIGS. 6(a)-(h) show an example loading process performed by copy holder moving system of FIGS. 3(a)-(h).

FIGS. 7(a)-(i) show an example unloading process performed by copy holder moving system of FIGS. 3(a)-(h).

DETAILED DESCRIPTION

FIG. 2. shows an example slide imaging apparatus **100** that includes an imaging system **110** and a copy holder moving system **120**.

The imaging system **110** may be the same as the imaging system **10** shown in FIG. 1(a), for example.

FIGS. 3(a)-(h) show the copy holder moving system **120** of FIG. 2 in more detail.

As shown in FIGS. 3(a)-(g), the copy holder moving system **120** includes a movable stage **130** and a copy holder **150**. The copy holder moving system also includes an indexing arm **170**, which is described in more detail below.

For clarity, FIGS. 3(a)-(f) and 3(h) show the copy holder moving system **120** without slides **80** being held by the copy holder **150**.

FIG. 3(g) shows slides **80** being held by the copy holder **150**, wherein a respective sample **85** is mounted on each slide **80**.

As shown e.g. in FIGS. 3(a) and 3(h), the movable stage **130** is the top plate in a three plate system that includes a middle plate **131a** and a bottom plate **131b**.

The copy holder moving system **120** includes a first motor (not shown) configured to move the movable stage **130** relative to the imaging system **110** along a first slide movement axis, referred to herein as a scan length axis (y-axis). In this example, the first motor is configured to move the movable stage **130** along the scan length axis by driving a first movement mechanism (not shown) The copy holder moving system **120** includes a second motor (not shown) configured to move the movable stage **130** relative to the imaging system **110** along a second slide movement axis, referred to herein as a swathe width axis (x-axis). In this example, the second motor is configured to move the middle plate **131a** and as such the moveable stage **130** along the swathe width axis (x-axis) by driving a second movement mechanism (not shown).

In this example, the bottom plate **131b** does not move relative to the imaging system **110**.

The first and second movement mechanism (and indeed the third movement mechanism discussed below) may each respectively include, for example, a leadscrew, a linear motor system or a piezo drive. Of course, other movement mechanisms for providing such relative movement between the movable stage **130** and the imaging system **110** could equally be envisaged.

As shown e.g. in FIG. **3(a)**, a top surface **130a** of the movable stage **130** includes a plurality of slide support pins **132**.

As shown e.g. in FIG. **3(b)**, the slide support pins **132** of this example include the following groups of slide support pins **132**:

- a first group of three slide support pins **132a** for supporting a slide held by the copy holder **150** in a first non-imaging location on the movable stage
- a second group of three slide support pins **132b** for supporting a slide held by the copy holder **150** in a second non-imaging location on the movable stage
- a third group of three slide support pins **132c** for supporting a slide held by the copy holder **150** in a first imaging location on the movable stage
- a fourth group of three slide support pins **132d** for supporting a slide held by the copy holder **150** in a second imaging location on the movable stage
- a fifth group of three slide support pins **132e** for supporting a slide held by the copy holder **150** in a third non-imaging location on the movable stage
- a sixth group of three slide support pins **132f** for supporting a slide held by the copy holder **150** in a fourth non-imaging location on the movable stage

The slide support pins **132** are therefore configured to support one or more slides **80** in two imaging locations on the movable stage **130**, wherein the imaging system **110** is configured to form an image of a sample mounted on a slide **80** located in each imaging location on the movable stage **130** during an image forming process that involves the movable stage **130** moving relative to the imaging system **110** along the scan length and swathe width axes. This image forming process is described in more detail below.

The imaging system **110** is not configured to form an image of a sample mounted on a slide **80** located in any of the non-imaging locations on the movable stage **130**. This allows the slide imaging apparatus **100** to be made more compact, since the imaging locations are close to each other and fall within a small surface area of the movable stage **130** so can be imaged with a smaller range of movement of the movable stage **130**.

At least the slide support pins for supporting slides **80** in the imaging locations (i.e. the slide support pins **132c-d** in the third and fourth groups) preferably have coplanar top surfaces **140a** for supporting slides **80**, so that the imaging system **110** is able to more easily retain focus of samples mounted on slides **80** supported by the slide support pins **132c-d** whilst it is moved by the moveable stage **130** during an image forming process as described below.

The slide support pins **132a-b**, **132e-f** for supporting slides in the non-imaging locations may also have coplanar top surfaces **140a** for supporting slides **80**, though this is less important, since as noted above the imaging system is not configured to form an image of a sample mounted on a slide **80** located in any of the non-imaging locations.

The top surface **130a** of the movable stage **130** is not flat, and includes a step at one end which forms a ledge **133**

having a top surface **133a**, as well as a push surface **133b** the function of which will be described in more detail below.

Each of these groups of the slide support pins **132a-132f** is arranged with a single pin for supporting one end of a slide **80** and a pair of pins for supporting an opposite end of the same slide **80**.

Each of the six groups of the slide support pins **132a-132f** as defined above is configured to support a typical pathology slide, which may have a length and width dimensions of 75 mm by 25 mm (3 by 1 inches).

In addition to the six groups defined to above, the slide support pins **132** also include a seventh group of slide support pins that includes a large slide support pin **132g** and the single pins from the third and fourth groups of slide support pins **132c-d**.

The large slide support pin **132g** is slightly taller than the slide support pins in the first-sixth groups of slide support pins **132a-132f**. This allows a large slide having a width dimension that is larger than a typical pathology slide to be supported by the seventh group of slide support pins, if a copy holder able to hold a large slide is used in place of the copy holder **150** shown in FIGS. **3(e)-(f)**.

Although a large slide supported by the seventh group of slide support pins would be inclined at an angle to a typical pathology slide supported by one of the six groups defined above (due to the slide support pin **132g** being taller), it would be straight forward for the imaging system **110** to incline its imaging plane accordingly so that it can form an image of a sample mounted on the large slide. Such techniques are known in the art.

The top surface **130a** of the movable stage **130** includes indexing formations, which in this example have the form of indexing pins **134**. The function of these indexing formations is described in more detail below.

The top surface **133a** of the ledge **133**, which is part of the top surface **130a** of the movable stage **130**, includes engagement formations, which in this example have the form of copy holder engagement pins **136**. The function of these engagement formations is described in more detail below. As will be described in more detail below, these copy holder engagement pins **136** are configured to engage corresponding engagement formations on the copy holder **150** so that the movable stage **130** is able to pull the copy holder **150** away from a predetermined copy holder loading location during a copy holder loading process.

FIGS. **3(e)** and **3(f)** show the copy holder **150** in further detail.

FIG. **3(e)** shows the copy holder **150** with a top surface **150a** facing upwards and a bottom surface **150b** facing downwards. FIG. **3(f)** shows the copy holder **150** with the bottom surface **150b** facing upwards.

The copy holder **150** includes six apertures having the form of slots **152a-152f**, each slot **152a-f** being configured to loosely hold a respective slide such that a slide is able to rest in each of the slots **152a-f** when the top surface **150a** is facing upwards but will fall out if the bottom surface **150b** is facing upwards.

As can be seen from FIG. **3(f)** the bottom surface **150b** of the copy holder **150** has a lip **152** at its periphery. As described in more detail below, this lip **152** is configured to engage with the copy holder engagement pins **136** so that the movable stage **130** is able to pull the copy holder **150** away from a predetermined copy holder loading location during a copy holder loading process.

As can also be seen from FIG. **3(f)**, the lip **152** includes cut-outs **153** configured to allow the copy holder engagement pins **136** formed on the movable stage **130** to pass

through the cut outs **153** (and therefore the lip **152**) during a pre-loading process described in more detail below.

FIG. 3(g) shows the copy holder **150** with a slide **80** loosely held in each aperture of the copy holder **150**.

The copy holder **150** is configured to be mounted to the movable stage **130** in each of three indexing positions that include:

- a first indexing position in which a first subset of two slides held by the first and second apertures **152a-b** of the copy holder **150** are supported in the first and second imaging positions by the slide support pins **132c-132d**
- a second indexing position in which a second subset of two slides held by the third and fourth apertures **152c-d** of the copy holder **150** are supported in the first and second imaging positions by the slide support pins **132c-132d**
- a third indexing position in which a third subset of two slides held by the fourth and fifth apertures **152e-f** of the copy holder **150** are supported in the first and second imaging positions by the slide support pins **132c-132d**

The copy holder **150** includes indexing formations, which in this example have the form of indexing holes **154** extending from the top surface **150a** to the bottom surface **150b** of the copy holder **150**. The indexing pins **134** on the movable stage **130** are configured to cooperate with (by extending into) the indexing holes **154** so as to act to fix the position of the copy holder **150** relative to the movable stage **130** when the copy holder **150** is mounted to the movable stage **130** in each of the first-third indexing positions.

FIG. 3(h) shows the copy holder **150** mounted to the third indexing position.

The copy holder **150** may be mounted to the movable stage **130** in any of the first-third indexing positions e.g. by a user manually placing the copy holder **150** on the movable stage **130** in the relevant indexing position. However, the copy holder **150** is preferably mounted to the movable stage **130** in any of the first-third indexing positions via the loading and/or indexing processes described below.

The copy holder **150** may be unmounted from any of the first-third indexing positions on the movable stage **130** e.g. by a user manually removing the copy holder **150** from the movable stage **130**. However, the copy holder **150** is preferably unmounted from any of the first-third indexing positions on the movable stage **130** via the unloading and/or indexing processes described below.

The imaging system **110** is configured to form an image of a sample mounted on a slide **80** located in each imaging location on the movable stage **130** during an image forming process that includes the movable stage **130** moving relative to the imaging system **110** along the scan length axis (y-axis) and swathe width axis (x-axis).

The image forming process may be performed with a plurality of slides **80** being held by the slots **152a-f** of the copy holder **150** and the copy holder **150** mounted to the movable stage **130** in one of the first-third indexing positions. The copy holder **150** may be mounted to the movable stage **130** in one of the indexing positions via the loading process described below.

During the image forming process, the imaging system **110** may form a respective image of a respective sample mounted on each slide **80** in the first and second imaging locations. If the imaging system **10** is used as the imaging system **110** in the slide imaging apparatus **100**, then each image may be formed plurality of swathes, wherein each swathe is formed by a group of scan lines, each scan line

being acquired using the scan line detector **14** from a respective elongate region **82** on the surface of the sample that extends along the swathe width axis (x-axis), wherein each group of scan lines is acquired whilst the slide **80** is moved relative to the scan line detector **14** along the scan length axis (y-axis), e.g. in the direction labelled **16** in FIG. 1(a), using the copy holder moving system **120**. After one swathe has been acquired, the slide **80** may be moved along the swathe width axis (x-axis), e.g. in the direction labelled **15** in FIG. 1(a), to allow a further swathe to be acquired by moving the slide **80** along the scan length axis (y-axis). This further swathe may be acquired by moving the slide **80** along the scan length axis in a direction opposite to the direction labelled **16** in FIG. 1(a), e.g. such that the slide **80** is moved along a serpentine path during the image forming process.

A focus setting of the imaging system **10** of FIG. 1(a) may be adjusted during the image forming process and even during the acquisition of an individual swathe, for example, by moving the imaging lens **12** along an imaging axis **13**. Techniques for measuring and dynamically adjusting focus to maintain the sample in focus along the length of the sample as the slide **80** is moved along the scan length axis are described in the literature, see e.g. U.S. Pat. No. 7,485,834, WO2013/017855 and US2014/0071438.

As shown in FIGS. 4(a)-(c), the indexing arm **170** of the copy holder moving system **120** includes a main body **172** and a stopping element **174** pivotally mounted to the main body **172** via a pivot **174a**.

As can be seen from FIGS. 4(a) and 4(b), the stopping element **174** can be rotated between an open position as shown in FIG. 4(b) and a closed position as shown in FIG. 4(a).

The indexing arm **170** also has a mouth **176** for holding the copy holder **150** during an indexing operation that will be described in more detail below.

The copy holder moving system **120** also has an indexing motor (not shown) configured to move the indexing arm **170** along an indexing axis (z-axis), e.g. by driving a third movement mechanism (e.g. including a leadscrew, not shown). In this example, the indexing axis (z-axis), scan length axis (y-axis) and swathe width axis (x-axis) are mutually perpendicular, but this need not be the case in all embodiments.

The main body **172** of the indexing arm is shown in FIG. 4(c), with the stopping element **174** and the pivot **174a** omitted from this drawing for clarity.

As can be seen from FIG. 4(c), a top surface **172a** and side walls **172b** formed on the top surface of the main body **172** of the indexing arm **170** provide copy holder guide surfaces, **172a**, **172b** for guiding the copy holder **150** whilst it is pushed into and/or pulled out from a slot **178**, e.g. by a user. The top surface **172a** provides a landing area for the copy holder **150** to rest on whilst it is pushed into and/or pulled out from the slot **178**.

The slot **178** may be included in a housing (not shown) of the slide imaging apparatus **100**, wherein the copy holder **150** is configured to be put in a predetermined copy holder loading location by pushing it at least partially into the slot **178**.

The stopping element **174** may be configured to, when it is rotated to the closed position shown in FIG. 4(a), stop the copy holder **150** from being pushed past the predetermined copy holder loading location when it is pushed into the slot **178**. The stopping element **174** may further be configured to, when it is rotated to the open position shown in FIG. 4(b),

allow the copy holder **150** to be pulled past the predetermined copy holder loading location by the movable stage **130**.

The first, second and indexing motors may be configured to move the movable stage **130** and the indexing arm **170** to perform three processes referred to herein as an indexing process, a loading process, an unloading process.

These processes will now be described with reference to FIGS. **5-7**, which show these processes using diagrammatical representations of the copy holder moving system **120**. Indexing Process

In the indexing process, the copy holder **150** is moved from a starting one of the indexing positions to a new one of the indexing positions.

An example indexing process will now be described with reference to FIGS. **5(a)-(j)** which shows the copy holder **150** being moved from the second indexing position to the first indexing position. Similar processes could be shown for moving the copy holder **150** from any indexing position to any other (e.g. adjacent) indexing position.

The indexing process starts with the copy holder **150** mounted to the movable stage **130** in the starting one of the indexing positions and the indexing arm **170** disengaged from (i.e. not holding) the copy holder **150**, e.g. as is the case at the end of the loading process described below.

In this example, the indexing process may include the following steps:

If necessary, the indexing arm **170** is moved along the indexing axis so that the mouth **176** of the indexing arm **170** is level with the copy holder **150**, as illustrated by FIG. **5(a)**.

The movable stage **130** is moved along the scan length axis towards the indexing arm **170** to engage the copy holder **150** in the mouth **176** of the indexing arm **170** so that the copy holder **150** can be supported by the mouth **176** of the indexing arm **170**, as illustrated by FIGS. **5(a)** and **5(b)**.

The indexing arm **170** is moved along the indexing axis to lift the copy holder **150** off the movable stage **130** and clear of the indexing pins **134**, as illustrated by FIGS. **5(b)** and **5(c)**.

The movable stage **130** is moved along the swathe width axis so that the copy holder **150** is located directly above the new indexing position (which in this example is the first indexing position), as illustrated by FIGS. **5(d)** and **5(e)**.

The indexing arm **170** is moved along the indexing axis to lower the copy holder **150** onto the movable stage **130**, thereby mounting the copy holder **150** to the movable stage **130** in the new indexing position, as illustrated by FIGS. **5(f)** and **5(g)**. The indexing pins **134** and corresponding indexing holes **154** help to correctly fix the position of the copy holder **150** relative to the movable stage **130** as the copy holder **150** is mounted to the movable stage **130** in the new indexing position.

The movable stage **130** is moved away from the indexing arm **170** along the scan length axis to disengage the copy holder **150** from the mouth **176**, as illustrated by FIGS. **5(g)** and **5(h)**.

Once the indexing process has been performed, the image forming process can commence to form an image of a sample mounted on a slide **80** newly located in each imaging position.

FIGS. **5(d)-(e)** and **5(i)-(j)** show the movable stage as having additional groups of slide support pins **132**, so that the slide support pins **132** can support all slides held by the

copy holder **150** regardless of which indexing position the copy holder **150** is in. For avoidance of any doubt, this feature is optional.

Loading Process

In the loading process, the copy holder **150** is moved from a predetermined copy holder loading location to be mounted on the movable stage **130** in a predetermined one of the indexing positions.

An example loading process will now be described with reference to FIGS. **6(a)-(h)**.

In this example, the loading process starts with top surface **172a** of the indexing arm **170** positioned along the indexing axis to be level with the top surface **133a** of the ledge **133** of the movable stage **130**, the movable stage **130** positioned along the scan length axis so that the ledge is under the stopping element **174**, and the stopping element **174** in its closed position.

In this example, the predetermined copy holder loading location has the copy holder **150** resting on the top surface **172a** of the indexing arm **170**, with the copy holder **150** pushed up against the stopping element **174**, as illustrated by FIGS. **6(a)** and **6(b)**. As can be seen from FIG. **6(b)**, with the copy holder **150** in the predetermined copy holder loading location, the copy holder engagement pins **136** formed on the ledge **133** of the movable stage **130** are underneath the copy holder **150**.

The copy holder **150** may be put in the copy holder loading location during a pre-loading process by pushing it at least partially into the slot **178** (as indicated by the arrow in FIG. **6(a)**), wherein a front end of the copy holder **150** is able to be pushed past the engagement pins **136** by virtue of the cut outs **153** included in the lip **152** on the bottom surface **150b** of the copy holder **150**. The stopping element **174**, rotated to its closed position, stops the copy holder **150** from being pushed past the predetermined copy holder loading location when it is pushed into the slot **178**.

In this example, the slot **178** in the housing of the slide imaging apparatus is located along in the indexing axis to be aligned with the ledge **133** on the movable stage **130** (which cannot itself move along the indexing axis) and located along the swathe width axis to be aligned with the copy holder guide surfaces **172a**, **172b** on the indexing arm (which itself cannot move along the swathe width axis) to facilitate the pre-loading process.

An optional alignment check may be performed using sensors mounted on the indexing arm **170** to make sure copy holder **150** is not skewed or otherwise out of the predetermined copy holder loading location relative to the copy holder guide surfaces **172a**, **172b** on the indexing arm **170**, prior to performing the loading process.

In this example, the loading process may include the following steps:

The movable stage **130** is moved a small distance along the swathe width axis (x-axis) so that each copy holder engagement pin **136** is located behind the lip **152** on the bottom surface **150b** of the copy holder **150**, as illustrated by FIGS. **6(b)** and **6(c)**.

The stopping element **174** is rotated to the open position to allow the copy holder **150** to be pulled away from the predetermined copy holder loading location and towards the imaging system **110** by the movable stage **130**.

The movable stage **130** is moved away from the indexing arm **170** along the scan length axis (y-axis), the copy holder engagement pins **136** engage with the lip **152** on the bottom surface **150b** of the copy holder **150** so that the movable stage **130** pulls the copy holder **150** away

13

from the predetermined copy holder loading location and towards the imaging system 110 until a rear end of the copy holder 150 sits on the top surface 172a of the indexing arm, as illustrated by FIGS. 6(c) and 6(d). The indexing arm 170 is moved along the indexing axis (z-axis) to disengage the copy holder 150 from the copy holder engagement pins 136 and lift the copy holder 150 off the movable stage 130, as illustrated by FIGS. 6(d) and 6(e). The copy holder 150 may be prevented from tipping off the top surface 172a of the indexing arm 170 at this time by two opposing guide ridges (not shown) that are located at top of the side walls 172b on the top surface of the indexing arm, and extend partially over the top surface 150a of the copy holder 150 when the copy holder 150 is resting on the top surface 172a of the indexing arm 170. These guide ridges, together with the guide surfaces 172a, 172b can be viewed as providing a slot at the top of the indexing arm 170.

The movable stage 130 is moved along the scan length axis (y-axis) towards the indexing arm 170 so that the copy holder 150 is located directly above the predetermined indexing position (which in this example is the second indexing position), as illustrated by FIGS. 6(e) and 6(f). Note that in this example, the features on the movable stage 130 and copy holder 150 (e.g. the slide support pins 132, the engagement pins 136 and the cut outs 153) and the slot 176 are configured so that an additional movement of the movable stage 130 along the swathe width axis (x-axis) is not needed to locate the copy holder 150 directly above one of the indexing positions. However, in other examples, there may be an additional step at this point of moving the movable stage 130 along the swathe width axis (x-axis) in order for the copy holder 150 to be located directly above the predetermined indexing position.

The indexing arm 170 is moved along the indexing axis to lower the copy holder 150 onto the movable stage 130, thereby mounting the copy holder 150 to the movable stage 130 in the predetermined indexing position, as illustrated by FIGS. 6(f) and 6(g). The indexing pins 134 and corresponding indexing holes 154 help to correctly fix the position of the copy holder 150 relative to the movable stage 130 as the copy holder 150 is mounted to the movable stage 130 in the predetermined indexing position.

The movable stage 130 is moved away from the indexing arm 170 along the scan length axis to disengage the copy holder 150 from the guide surfaces 172a, 172b of the indexing arm, as illustrated by FIGS. 6(g) and 6(h).

Once the loading process has been performed, the image forming process can commence to form an image of a sample mounted on a slide 80 located in each imaging position.

Unloading Process

In the unloading process, the copy holder 150 is moved from being mounted on the movable stage 130 in a predetermined one of the indexing positions to a predetermined copy holder unloading location.

An example unloading process will now be described with reference to FIGS. 7(a)-(i).

In this example, the unloading process starts with the copy holder 150 mounted to the movable stage 130 in a predetermined one of the indexing positions (which in this example is the second indexing position), the indexing arm 170 disengaged from (i.e. not holding) the copy holder 150 and the guide surfaces 172a, 172b of the indexing arm 170

14

aligned with the copy holder 150, e.g. as may be the case at the end of the loading process described above.

The unloading process may include the following steps: The movable stage 130 is moved towards the indexing arm 170 so that a rear end of the copy holder 150 rests on the top surface 172a of the indexing arm 170, as illustrated by FIGS. 7(a) and 7(b).

The indexing arm 170 is moved along the indexing axis to lift the copy holder 150 off the movable stage 130 and clear of the indexing pins 134, as illustrated by FIGS. 7(b) and 7(c). The copy holder 150 may be prevented from tipping off the top surface 172a of the indexing arm 170 at this time by the two opposing guide ridges located at top of the side walls 172b on the top surface of the indexing arm 170, as described above.

The movable stage 130 is moved along the scan length axis so that the front end of the copy holder 150 is over the ledge 133 of the movable stage 130, as illustrated by FIGS. 7(c) and 7(d).

If necessary, the movable stage 130 is moved a small distance along the swathe width axis (x-axis) so that each copy holder engagement pin 136 is aligned with a cut out 153 in the lip 152 on the bottom surface 150b of the copy holder 150 along the swathe width axis (x-axis), as illustrated by FIGS. 7(e) and 7(f). This movement allows the copy holder 150 to be pulled out of the slide scanning apparatus 100 (e.g. by a user), when the copy holder 150 has been moved to the predetermined copy holder unloading location. Note that if the copy holder engagement pins 136 were not aligned with the cut outs 153 along the swathe width axis (x-axis), then an engagement between the copy holder engagement pins 136 and the lip 152 on the bottom surface 150b of the copy holder 150 could prevent a user from pulling the copy holder 150 out of the slide scanning apparatus from the predetermined copy holder unloading location.

The indexing arm 170 is moved along the indexing axis (z-axis) to lower the copy holder 150 onto the ledge 133 of movable stage 130, as illustrated by FIGS. 7(g) and 7(h).

The movable stage 130 is moved along the scan length axis (y-axis) towards the indexing arm 170 so that the push surface 133b of the movable stage pushes the copy holder 150 across the top surface 172a of the indexing arm 170 and at least partially out through the slot 178 in the housing of the slide imaging apparatus 100 to the predetermined copy holder unloading location, as illustrated by FIGS. 7(h) and 7(i).

Once the unloading process has been performed, a user can remove the copy holder 150 by pulling it out of the slot 178 in the housing.

When used in this specification and claims, the terms “comprises” and “comprising”, “including” and variations thereof mean that the specified features, steps or integers are included. The terms are not to be interpreted to exclude the possibility of other features, steps or integers being present.

The features disclosed in the foregoing description, or in the following claims, or in the accompanying drawings, expressed in their specific forms or in terms of a means for performing the disclosed function, or a method or process for obtaining the disclosed results, as appropriate, may, separately, or in any combination of such features, be utilised for realising the invention in diverse forms thereof.

While the invention has been described in conjunction with the exemplary embodiments described above, many

15

equivalent modifications and variations will be apparent to those skilled in the art when given this disclosure. Accordingly, the exemplary embodiments of the invention set forth above are considered to be illustrative and not limiting. Various changes to the described embodiments may be made without departing from the spirit and scope of the invention.

For the avoidance of any doubt, any theoretical explanations provided herein are provided for the purposes of improving the understanding of a reader. The inventors do not wish to be bound by any of these theoretical explanations.

All references referred to above are hereby incorporated by reference.

The invention claimed is:

1. A slide imaging apparatus that includes:
a copy holder moving system; and
an imaging system;

wherein the copy holder moving system includes:

a movable stage configured to move along first and second slide movement axes relative to the imaging system, wherein the imaging system is configured to form an image of at least a portion of a sample mounted on a slide located at an imaging location on the movable stage during an image forming process that includes the movable stage moving relative to the imaging system along the first and second slide movement axes;

a copy holder configured to be mounted to the movable stage, wherein the copy holder includes:

a plurality of apertures, each aperture being configured to hold a respective slide;
an indexing arm for holding the copy holder; and
an indexing motor configured to move the indexing arm along an indexing axis that is nonparallel with respect to both the first and second slide movement axes; and

wherein the copy holder is configured to be mounted to the movable stage in each of a plurality of indexing positions.

2. The slide imaging apparatus according to claim 1, wherein the copy holder moving system includes one or more motors configured to move the movable stage along the first slide movement axis and separately along the second slide movement axis.

3. The slide imaging apparatus according to claim 1, wherein the copy holder moving system is configured to perform an indexing process that moves the copy holder from one of the plurality of indexing positions to another of the plurality of indexing positions.

4. The slide imaging apparatus according to claim 1 wherein: the copy holder moving system is configured to move from one of the plurality of indexing positions to another of the plurality of indexing positions by moving the indexing motor along the indexing axis and by moving the movable stage being moved along the first and second slide movement axes by one or more motors.

5. The slide imaging apparatus according to claim 1, wherein:

the copy holder moving system is configured to perform a copy holder loading process that moves the copy holder from a predetermined copy holder loading location to be mounted on the movable stage in one of the plurality of indexing positions; and

a copy holder loading process that moves the copy holder from the predetermined copy holder loading location to be mounted on the movable stage in one of the indexing positions includes moving the indexing arm by an

16

indexing motor along an indexing axis as well as the movable stage being moved one or more motors along the first and/or second slide movement axes.

6. The slide imaging apparatus according to claim 1, wherein the copy holder and the movable stage each have one or more engagement formations, which are configured to engage with each other to facilitate the movable stage pulling the copy holder away from a predetermined copy holder loading location during the copy holder loading process.

7. The slide imaging apparatus according to claim 6, wherein the one or more engagement formations include one or more pins formed on the movable stage and a lip located on a bottom surface of the copy holder.

8. The slide imaging apparatus according to claim 1, wherein:

the copy holder moving system is configured to perform a copy holder unloading process that moves the copy holder from being mounted on the movable stage in one of the indexing positions to a predetermined copy holder unloading location; and

the copy holder unloading process includes the indexing arm being moved by an indexing motor along the indexing axis and the movable stage being moved.

9. The slide imaging apparatus according to any claim 1, wherein the copy holder and the movable stage each have one or more indexing formations, which are configured to integrate with each other so as to act to fix a position of the copy holder relative to the movable stage when the copy holder is mounted to the movable stage in an indexing position of the plurality of indexing positions.

10. The slide imaging apparatus according to claim 9, wherein the indexing formations include:

one or more pins formed on the movable stage and one or more corresponding holes formed in the copy holder; or
one or more pins formed on the copy holder and one or more corresponding holes formed in the movable stage.

11. The slide imaging apparatus of claim 1, wherein the movable stage includes a set of structural supports to support subsets of the slides held by the copy holder in corresponding imaging locations.

12. A method for imaging a set of sample slices, the method comprising: capturing, using an imaging system, a first image of a first sample slice of the set of sample slices, the first sample slice being positionally constrained within an aperture in a movable stage, wherein the movable stage is configured to move along first and second slide movement axes relative to the imaging system; using a copy holder moving system to move the movable stage, wherein the copy holder includes: a plurality of apertures, each aperture being configured to hold a respective slide, the plurality of apertures including the aperture; an indexing arm for holding a copy holder; and an indexing motor configured to move the indexing arm along an indexing axis that is nonparallel with respect to both the first and second slide movement axes; and capturing, using the imaging system, a second image of a second sample slice of the set of sample slices.

13. The method of claim 12, wherein the copy holder moving system includes one or more motors, and wherein using the copy holder moving system to move the movable stage includes using the one or more motors move the movable stage along the first slide movement axis and separately along the second slide movement axis.

14. The method of claim 12, further comprising: performing, using the copy holder moving system, an indexing process that moves the copy holder from one

17

of the plurality of indexing positions to another of the plurality of indexing positions.

15. The method of claim 12 wherein:
the copy holder moving system includes an indexing arm for holding the copy holder and an indexing motor configured to move the indexing arm along an indexing axis that is nonparallel with respect to both the first and second slide movement axes; and
the method further comprises, moving, using the copy holder moving system, from one of the plurality of indexing positions to another of the plurality of indexing positions for image capture by moving the indexing motor along the indexing axis as well as the movable stage being moved along the first and second slide movement axes by one or more motors.

16. The method of claim 12, further comprising:
performing, using the copy holder moving system, a copy holder loading process that moves the copy holder from a predetermined copy holder loading location to be mounted on the movable stage in one of the plurality of indexing positions; and
wherein the copy holder loading process includes moving the copy holder from the predetermined copy holder loading location to be mounted on the movable stage in one of the indexing positions, and
wherein the copy holder is moved by moving an indexing arm by an indexing motor along an indexing axis and

18

by moving the movable stage being moved one or more motors along the first and/or second slide movement axes.

17. The method of claim 12, wherein the copy holder and the movable stage each have one or more engagement formations, and wherein the method further comprises:
pulling the copy holder away from a predetermined copy holder loading location during the copy holder loading process by engaging the one or more engagement formations of the copy holder with the one or more engagement formations of the movable stage.

18. A method of claim 17, wherein the one or more engagement formations include one or more pins formed on the movable stage and a lip located on a bottom surface of the copy holder.

19. The method of claim 12, wherein:
performing, using the copy holder moving system, a copy holder unloading process that moves the copy holder from being mounted on the movable stage in one of the indexing positions to a predetermined copy holder unloading location; and
performing the copy holder unloading process by moving the indexing arm by an indexing motor along the indexing axis and the movable stage being moved.

* * * * *