



(19) **United States**

(12) **Patent Application Publication**
Birnkrant et al.

(10) **Pub. No.: US 2019/0287370 A1**

(43) **Pub. Date: Sep. 19, 2019**

(54) **HIGH SENSITIVITY FIBER OPTIC BASED DETECTION**

(71) Applicant: **Carrier Corporation**, Jupiter, FL (US)

(72) Inventors: **Michael J. Birnkrant**, Wethersfield, CT (US); **David L. Lincoln**, Johnston, RI (US); **Jennifer M. Alexander**, Glastonbury, CT (US); **Peter R. Harris**, West Hartford, CT (US)

(21) Appl. No.: **16/349,423**

(22) PCT Filed: **Nov. 8, 2017**

(86) PCT No.: **PCT/US2017/060607**

§ 371 (c)(1),

(2) Date: **May 13, 2019**

Related U.S. Application Data

(60) Provisional application No. 62/425,673, filed on Nov. 23, 2016, provisional application No. 62/420,592, filed on Nov. 11, 2016.

Publication Classification

(51) **Int. Cl.**

G08B 17/107 (2006.01)

G08B 13/187 (2006.01)

G08B 17/06 (2006.01)

(52) **U.S. Cl.**

CPC **G08B 17/107** (2013.01); **G08B 17/06** (2013.01); **G08B 13/187** (2013.01)

(57)

ABSTRACT

A detection system for measuring one or more conditions within a predetermined area includes a fiber harness having at least one fiber optic cable for transmitting light, the at least one fiber optic cable defining a node arranged to measure the one or more conditions. A control system is operably coupled to the fiber harness such that scattered light associated with the node is transmitted to the control system, wherein the control system analyzes the scattered light to determine at least one of a presence and magnitude of the one or more conditions at the node. An optical element is operably connected to the fiber harness or control system to alter or define the operational range or sensitivity of the node.

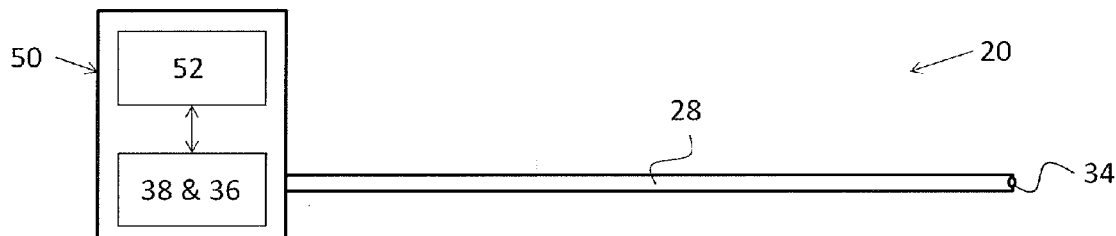

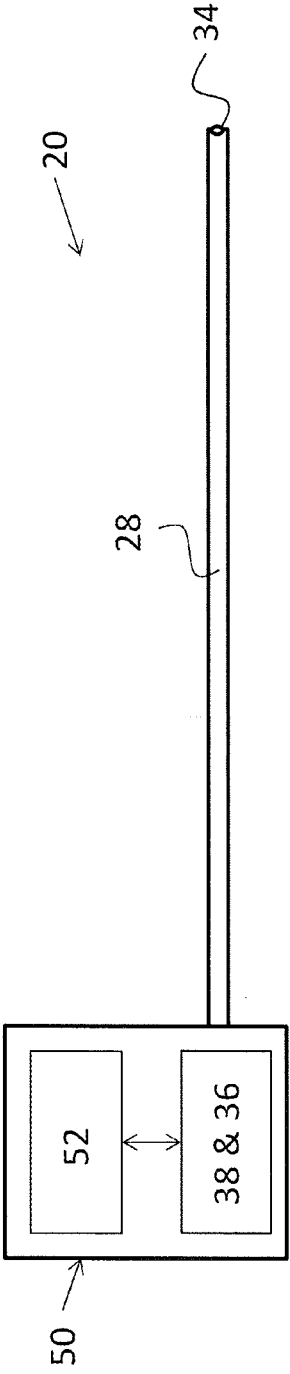

FIG. 1

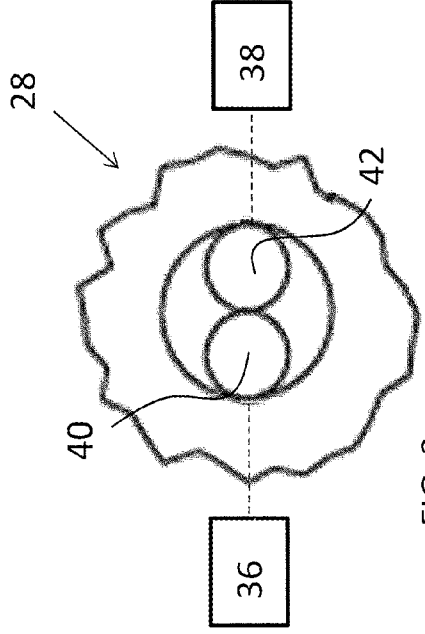

FIG. 3

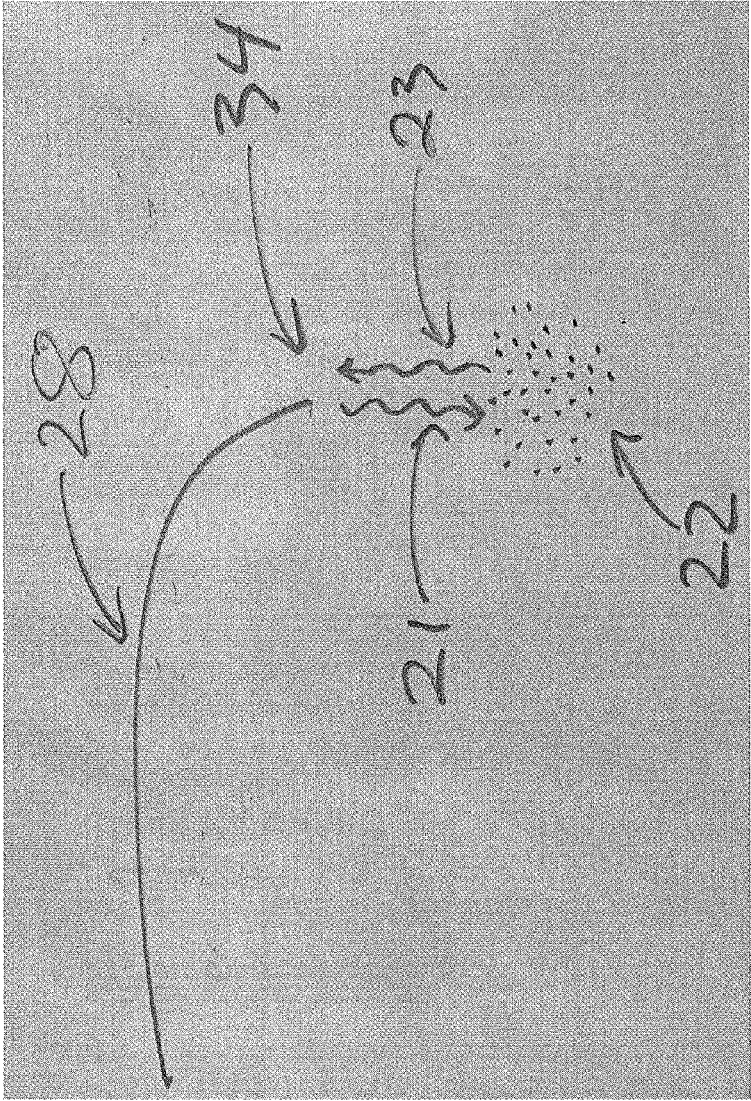

FIG. 1A

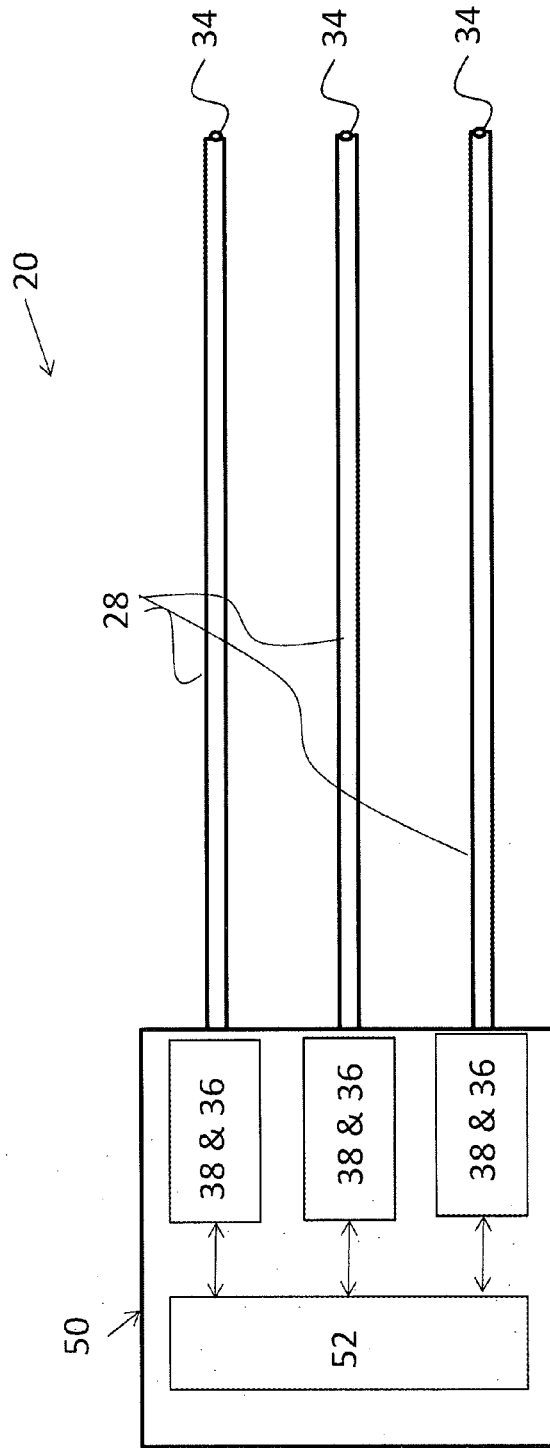

FIG. 2A

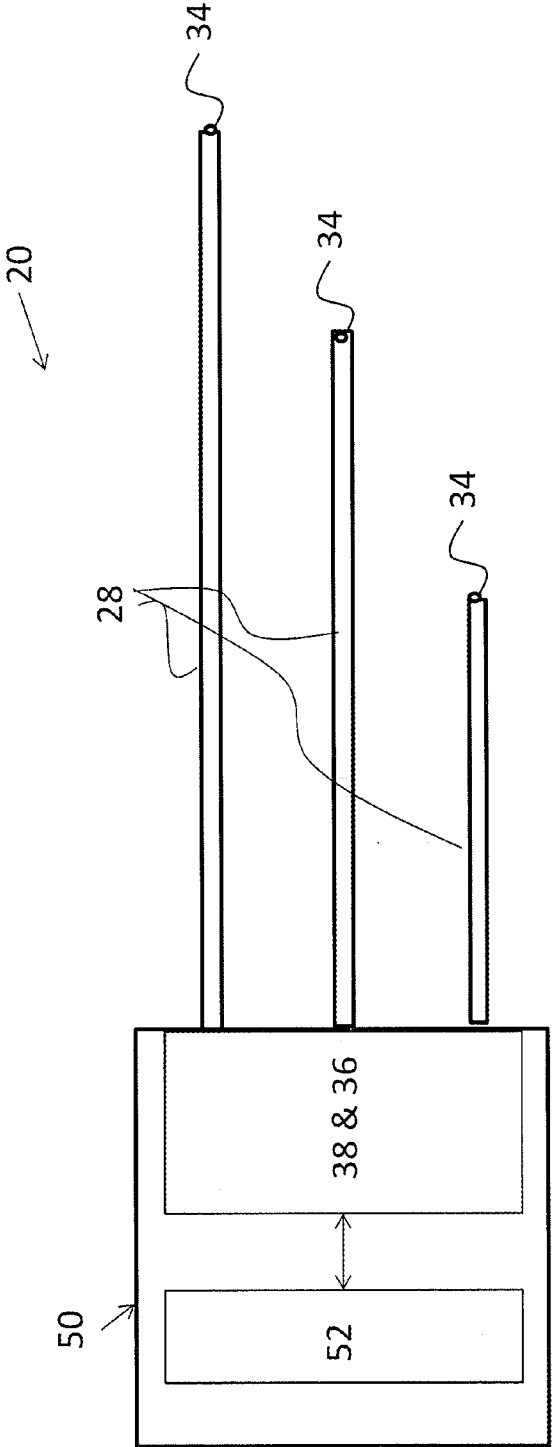

FIG. 2B

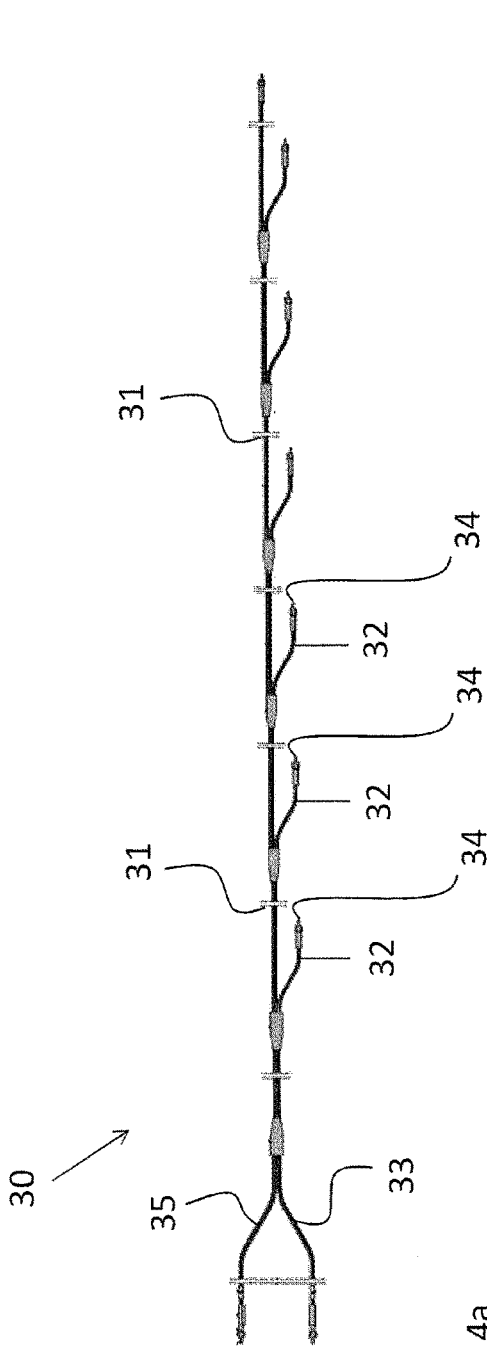

FIG. 4a

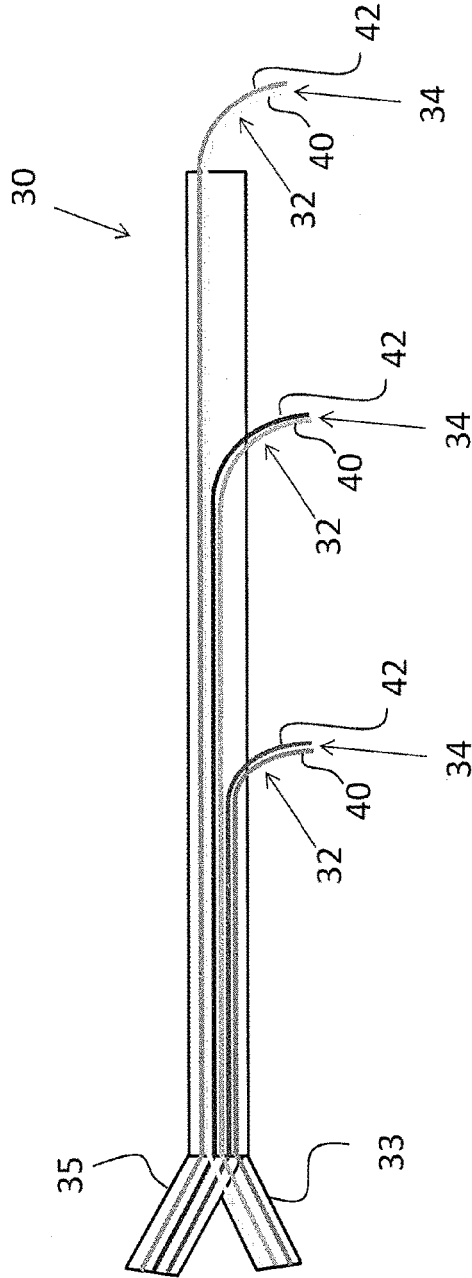

FIG. 4b

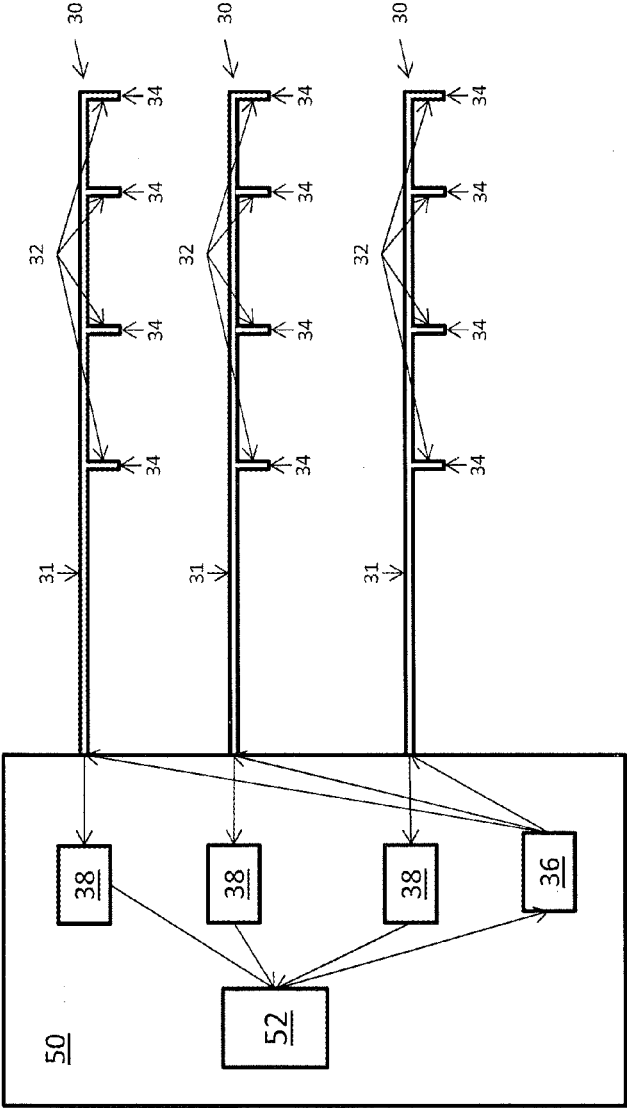

FIG. 5

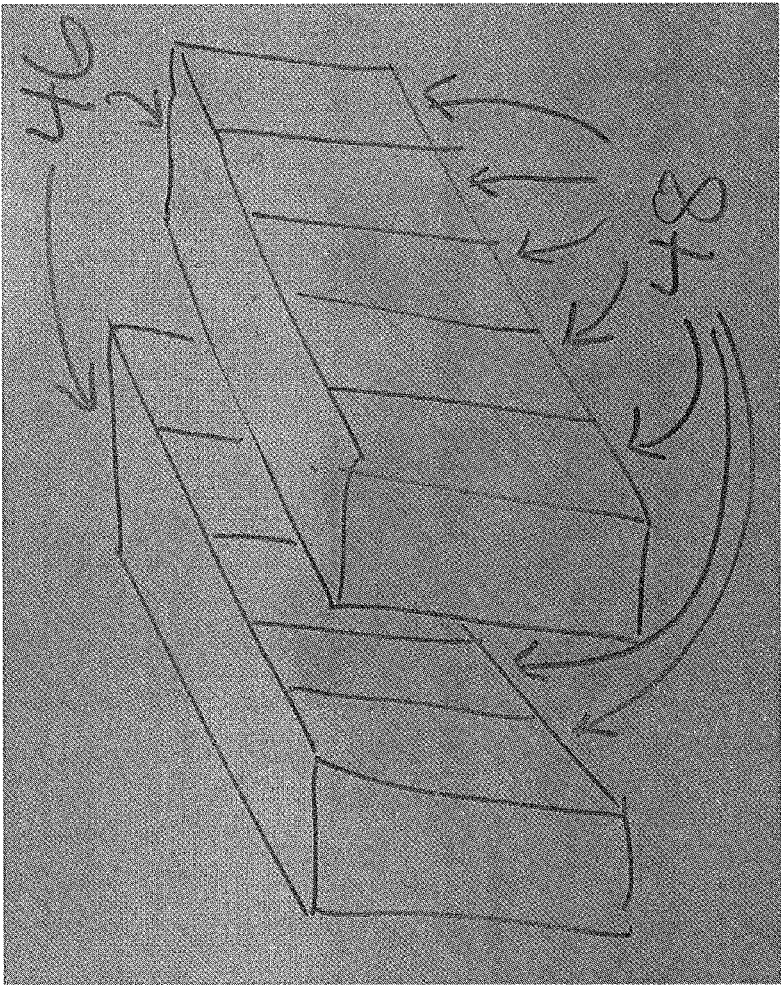

FIG. 6

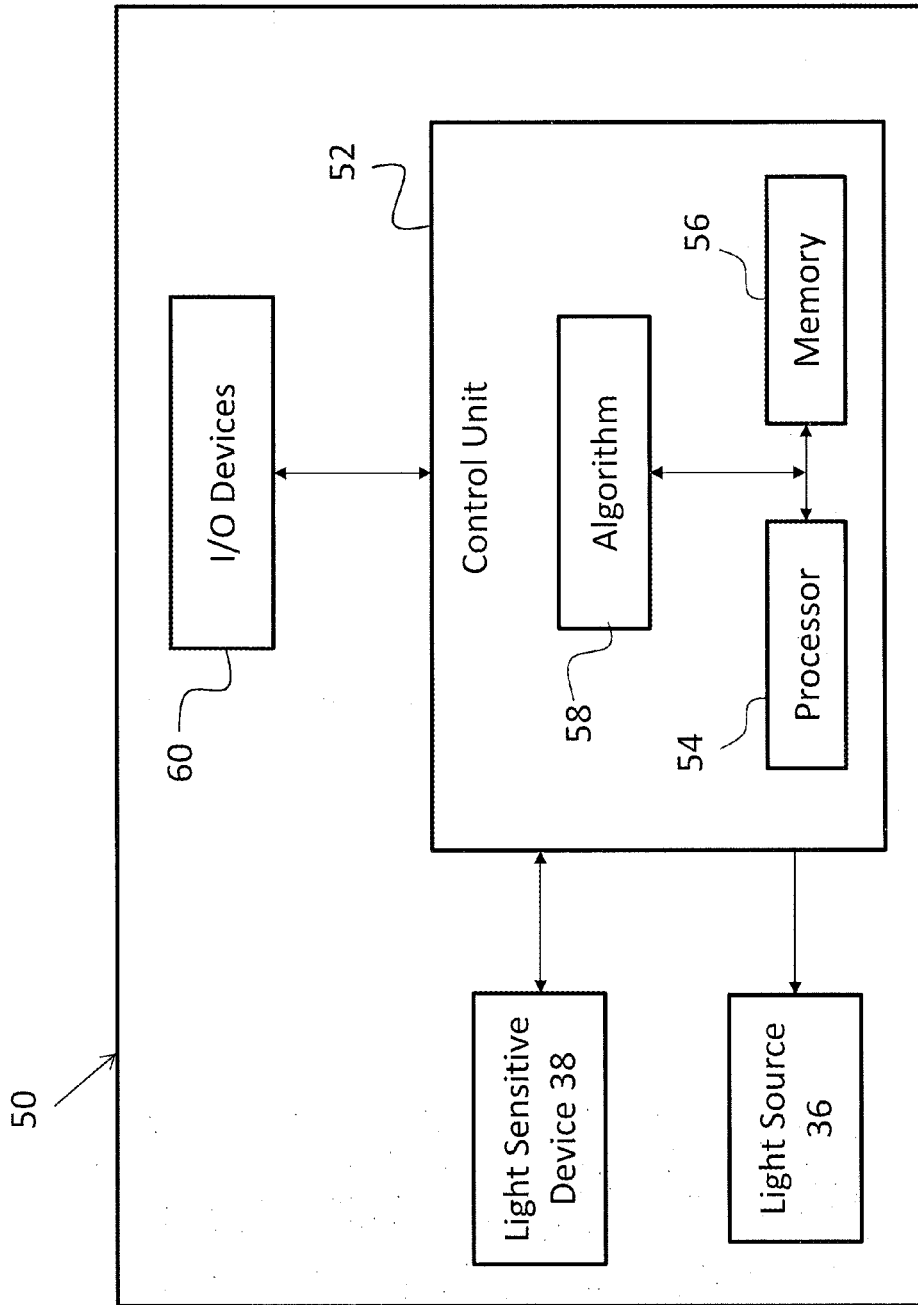
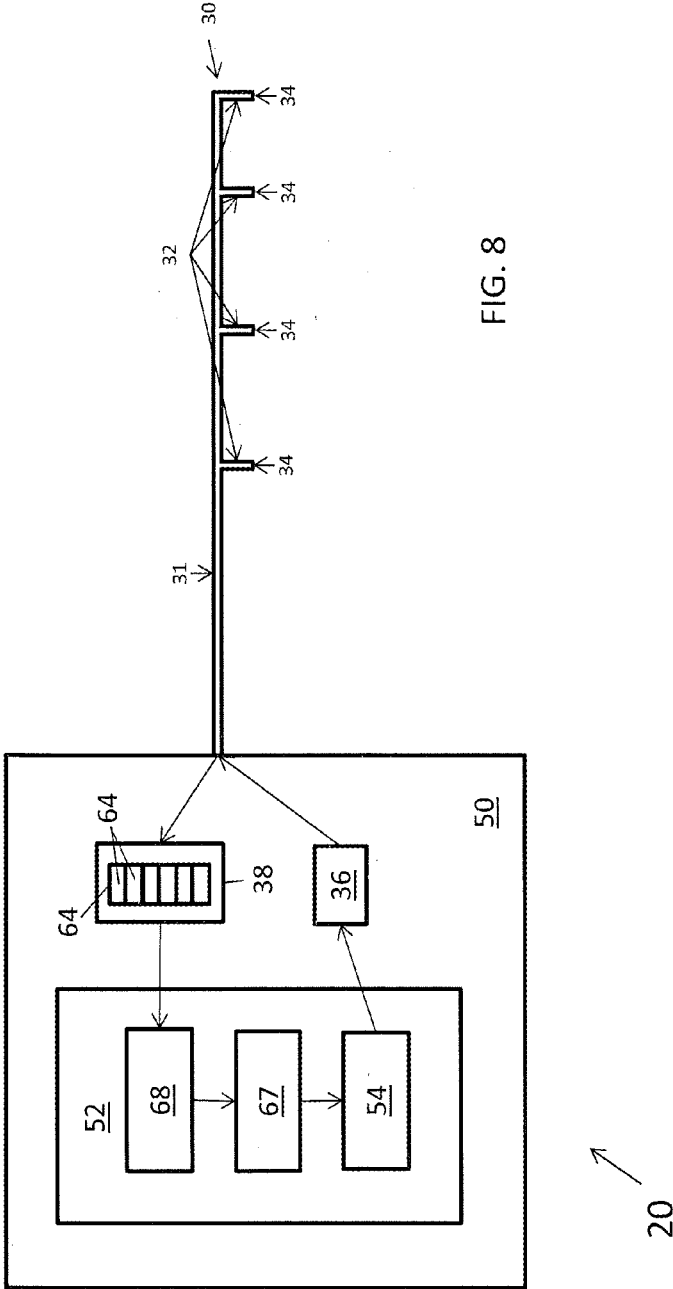

FIG. 7



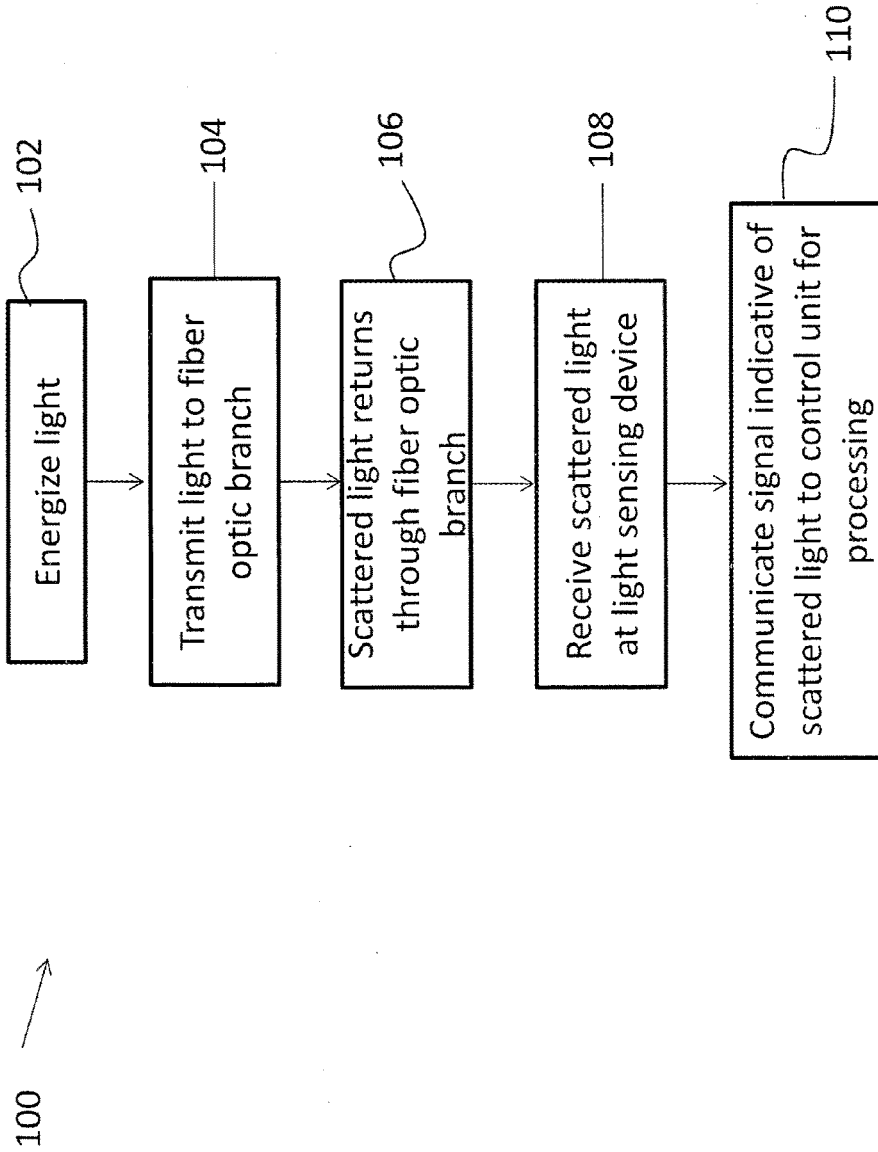

FIG. 9

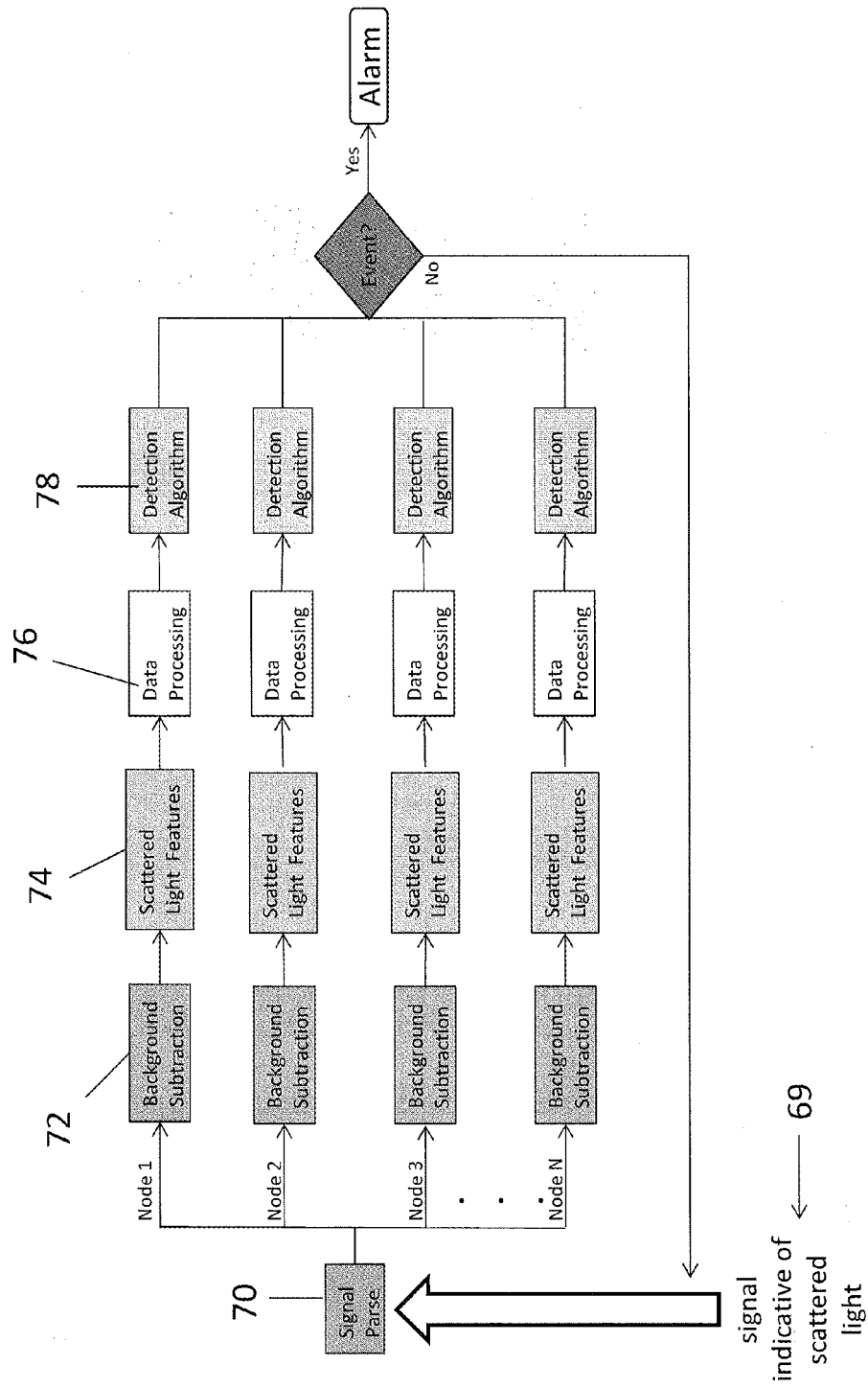

FIG. 10

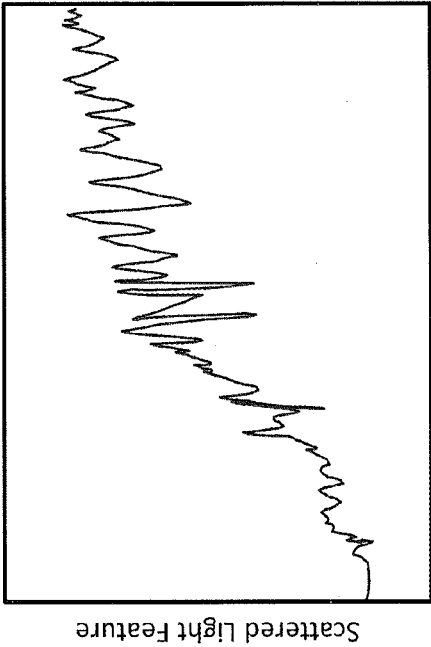

FIG. 11a

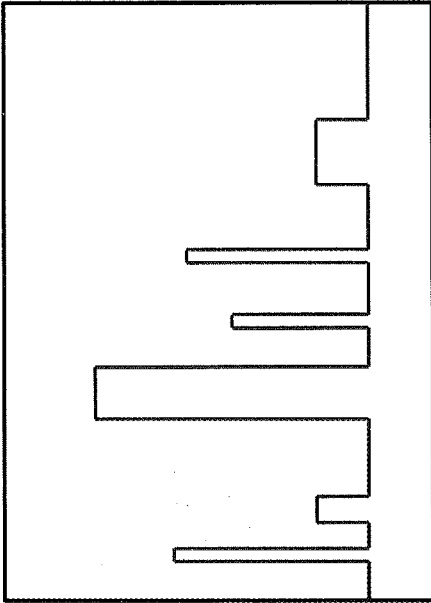

FIG. 11b

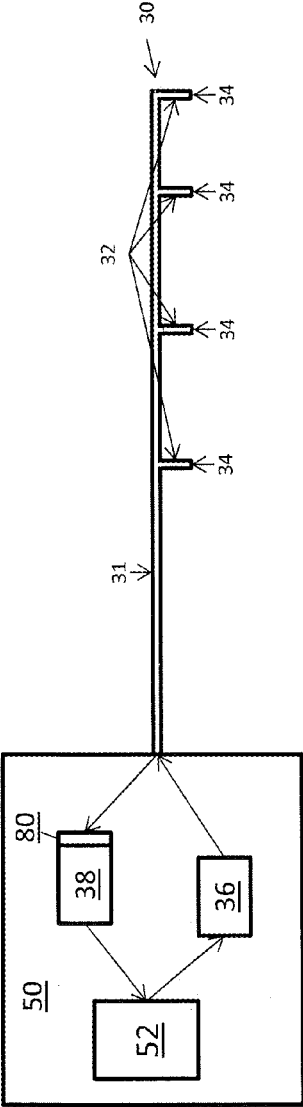

FIG. 12

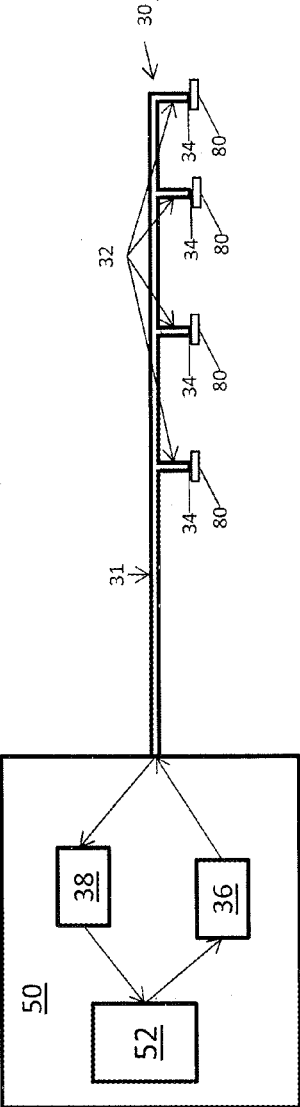

FIG. 13

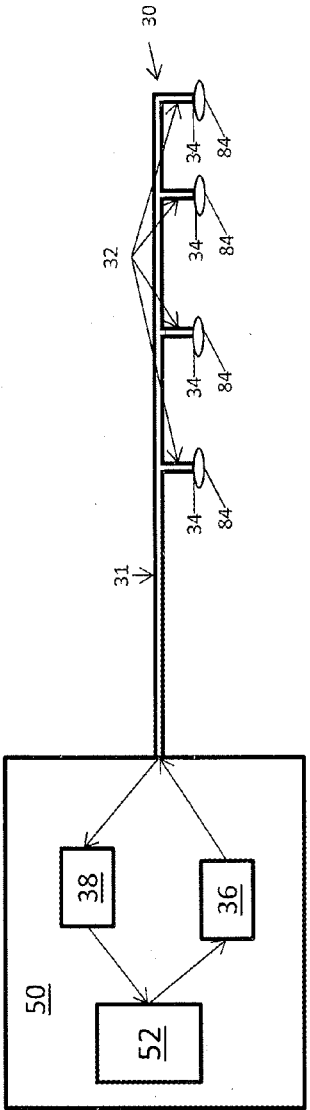

FIG. 14

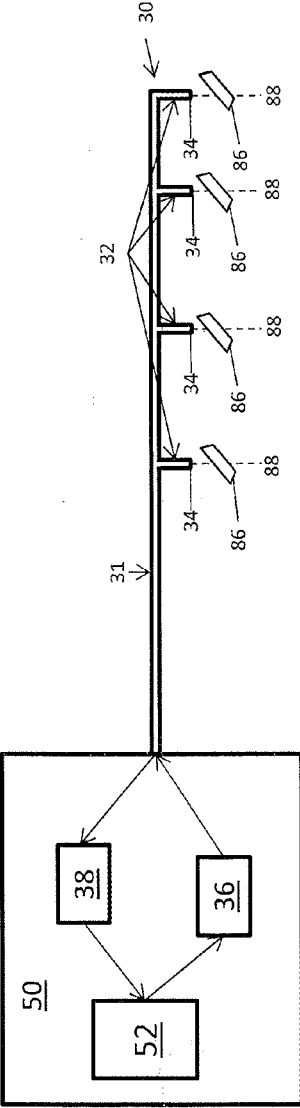

FIG. 15

FIG. 16a

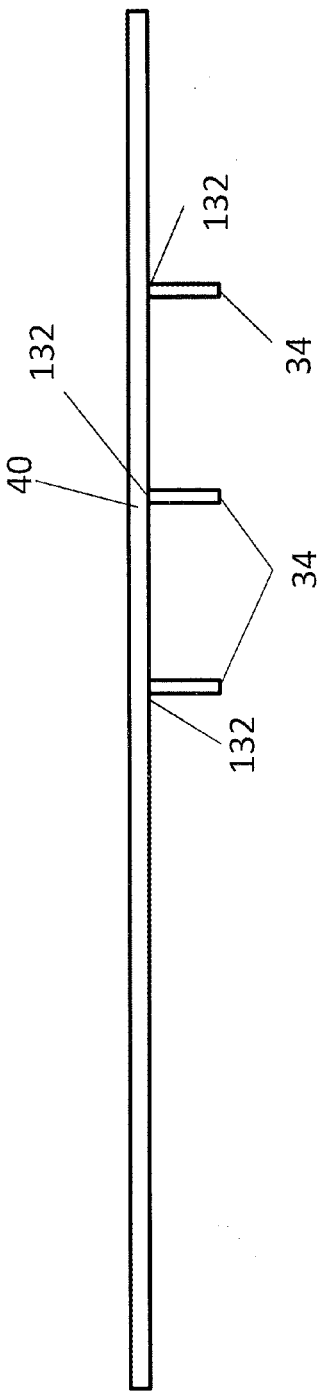
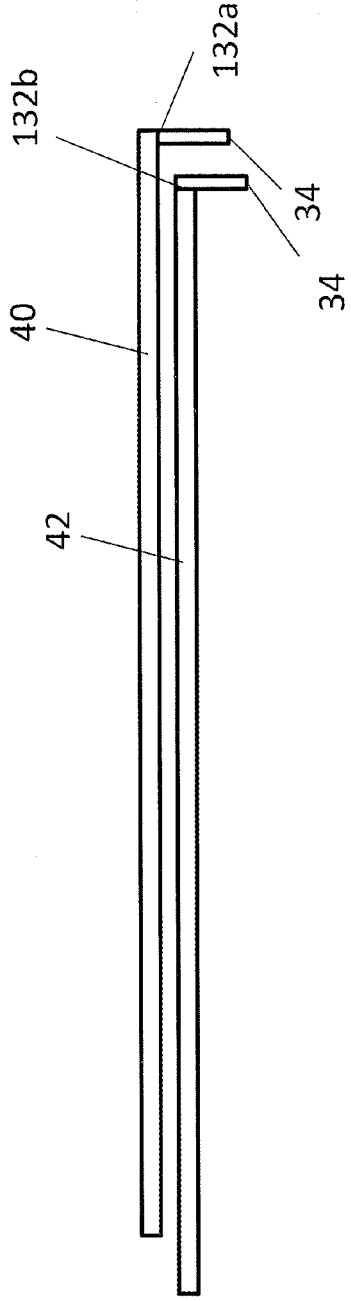

FIG. 16b



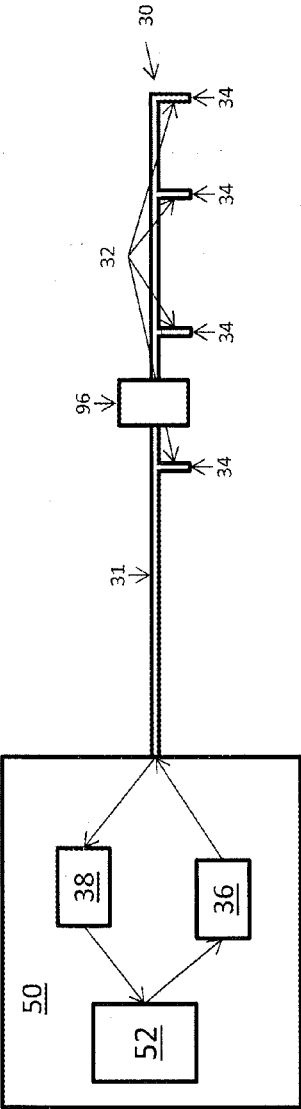

FIG. 17

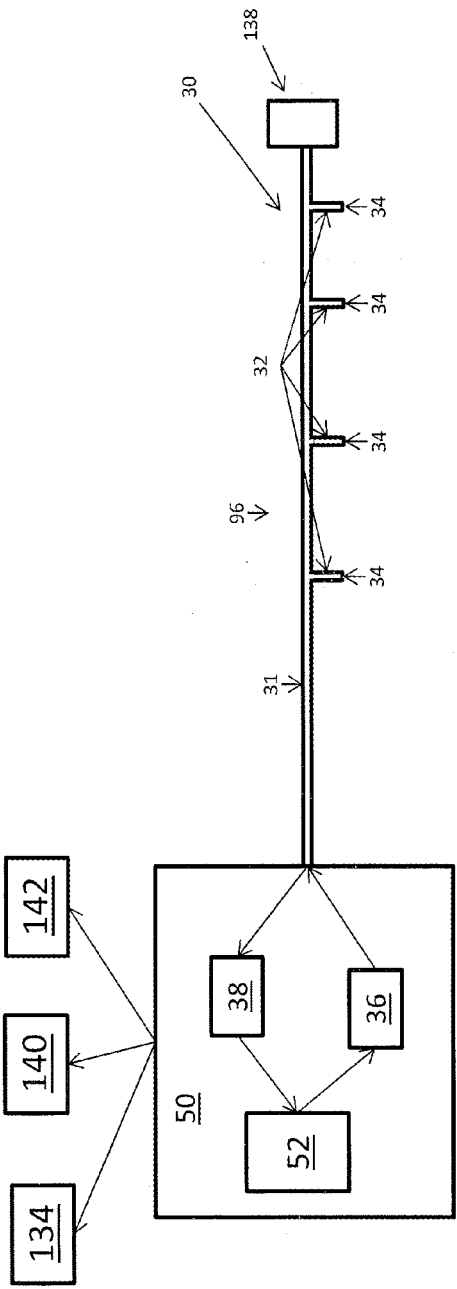

FIG. 18

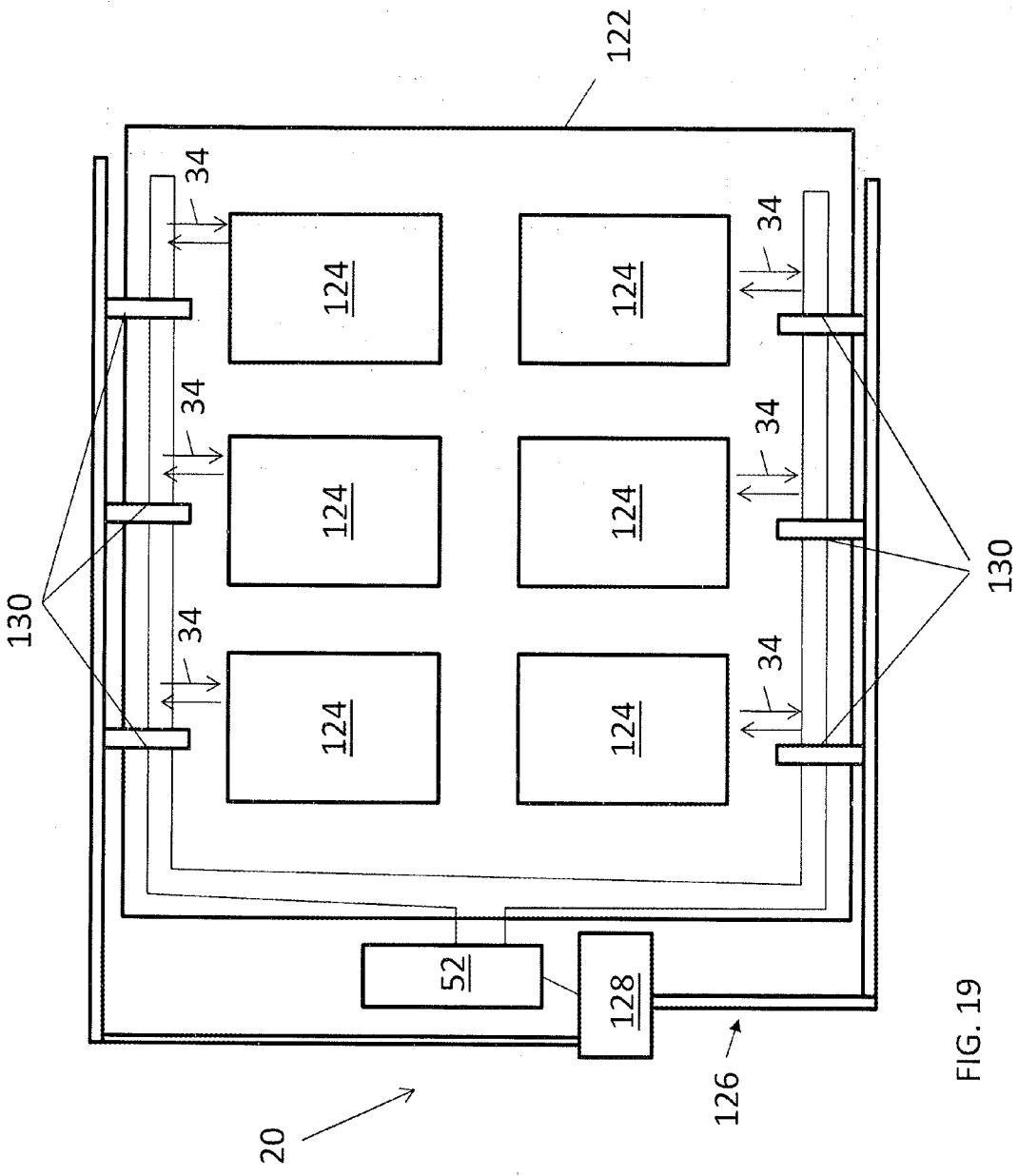

FIG. 19

HIGH SENSITIVITY FIBER OPTIC BASED DETECTION

BACKGROUND

[0001] Embodiments of this disclosure relate generally to a system for detecting conditions within a predetermined space and, more particularly, to a fiber optic detection system.

[0002] Conventional smoke detection systems operate by detecting the presence of smoke or other airborne pollutants. Upon detection of a threshold level of particles, an alarm or other signal, such as a notification signal, may be activated and operation of a fire suppression system may be initiated.

[0003] High sensitivity smoke detection systems may incorporate a pipe network consisting of one or more pipes with holes or inlets installed at positions where smoke or pre-fire emissions may be collected from a region or environment being monitored. Air is drawn into the pipe network through the inlets, such as via a fan, and is subsequently directed to a detector. In some conventional smoke detection systems, individual sensor units may be positioned at each sensing location, and each sensor unit has its own processing and sensing components.

[0004] Delays in the detecting the presence of the fire may occur in conventional point smoke detectors and also pipe network detection systems, for example due to the smoke transport time. In pipe network detection systems, due to the size of the pipe network, there is a typically a time delay between when the smoke enters the pipe network through an inlet and when that smoke actually reaches the remote detector. In addition, because smoke or other pollutants initially enter the pipe network through a few of the inlets, the smoke mixes with the clean air provided to the pipe from the remainder of the inlets. As a result of this dilution, the smoke detectable from the smoke and air mixture may not exceed the threshold necessary to indicate the existence of a fire.

SUMMARY

[0005] In one embodiment, a detection system for measuring one or more conditions within a predetermined area includes a fiber harness having at least one fiber optic cable for transmitting light, the at least one fiber optic cable defining a node arranged to measure the one or more conditions. A control system is operably coupled to the fiber harness such that scattered light associated with the node is transmitted to the control system, wherein the control system analyzes the scattered light to determine at least one of a presence and magnitude of the one or more conditions at the node. An optical element is operably connected to the fiber harness or control system to alter or define the operational range or sensitivity of the node.

[0006] Additionally or alternatively, in this or other embodiments the optical element is an expanding optical element.

[0007] Additionally or alternatively, in this or other embodiments the optical element is located at the node.

[0008] Additionally or alternatively, in this or other embodiments the optical element reduces divergence of an outgoing light and/or increases an amount of scattered light received by the node.

[0009] Additionally or alternatively, in this or other embodiments the optical element is a focusing lens.

[0010] Additionally or alternatively, in this or other embodiments the optical element is fused to the node.

[0011] Additionally or alternatively, in this or other embodiments the optical element is located at the node and includes a shaped fiber.

[0012] Additionally or alternatively, in this or other embodiments the optical element is configured to reduce scattering of light off of a lens face.

[0013] Additionally or alternatively, in this or other embodiments the optical element includes beam steering features.

[0014] Additionally or alternatively, in this or other embodiments the optical element is a mirror located near the node.

[0015] Additionally or alternatively, in this or other embodiments the mirror is positioned off-axis of the node and/or at an angle relative to a node axis.

[0016] Additionally or alternatively, in this or other embodiments the mirror is configured to move.

[0017] Additionally or alternatively, in this or other embodiments the one or more conditions includes the presence of one or more of smoke or fire in the predetermined area.

[0018] In another embodiment, a method of measuring one or more conditions within a predetermined area includes transmitting light along a fiber harness to a node of a fiber optic cable of the fiber harness, the node arranged to measure the one or more conditions, receiving scattered light received by the node, modifying a sensitivity of the node by utilizing an optical element, and analyzing the scattered light associated with the node to determine at least one of the presence and magnitude of the condition within the predetermined area.

[0019] Additionally or alternatively, in this or other embodiments a range of the node is modified by utilizing the optical element.

[0020] Additionally or alternatively, in this or other embodiments scattered light is received at the node via the optical element.

[0021] Additionally or alternatively, in this or other embodiments the divergence of an outgoing light and/or modifying an amount of scattered light received by the node is modified by utilizing the optical element.

[0022] Additionally or alternatively, in this or other embodiments the optical element is a lens fused to or integrated into the fiber cable at the node.

[0023] Additionally or alternatively, in this or other embodiments the optical element is a mirror positioned at and/or near the node.

[0024] Additionally or alternatively, in this or other embodiments the mirror is located off-axis of the node and/or at an angle relative to a node axis.

[0025] Additionally or alternatively, in this or other embodiments the one or more conditions includes the presence of one or more smoke or fire in the predetermined areas.

BRIEF DESCRIPTION OF THE DRAWINGS

[0026] The subject matter, which is regarded as the present disclosure, is particularly pointed out and distinctly claimed in the claims at the conclusion of the specification. The foregoing and other features, and advantages of the present

disclosure are apparent from the following detailed description taken in conjunction with the accompanying drawings in which:

[0027] FIG. 1 is schematic diagram of a detection system according to an embodiment;

[0028] FIG. 1A is a schematic diagram of light transmission at a node of a detection system according to an embodiment;

[0029] FIG. 2A is a schematic diagram of a detection system according to another embodiment;

[0030] FIG. 2B is a schematic diagram of a detection system according to another embodiment;

[0031] FIG. 3 is a cross-sectional view of a fiber optic node of the fiber harness of FIG. 1 according to an embodiment;

[0032] FIG. 4A is a side view of a fiber harness of a detection system according to an embodiment;

[0033] FIG. 4B is a schematic diagram of a fiber harness of a detection system according to an embodiment;

[0034] FIG. 5 is a schematic diagram of a detection system including a plurality of fiber harnesses according to an embodiment;

[0035] FIG. 6 is a perspective view of an area within a building to be monitored by a detection system according to an embodiment;

[0036] FIG. 7 is a schematic diagram of a control system of the detection system according to an embodiment;

[0037] FIG. 8 is another schematic diagram of a detection system including an avalanche photo diode sensor according to an embodiment;

[0038] FIG. 9 is a method of operating a detection system according to an embodiment;

[0039] FIG. 10 is a schematic diagram of process flow for evaluating the signals generated by the light sensitive device according to an embodiment;

[0040] FIGS. 11A and 11B are diagrams illustrating the signals recorded by the detection system over time for various predefined conditions or events according to an embodiment;

[0041] FIG. 12 is another schematic diagram of a detection system;

[0042] FIG. 13 is yet another schematic diagram of a detection system;

[0043] FIG. 14 is a schematic diagram of a detection system using lenses;

[0044] FIG. 15 is another schematic diagram of a detection system using mirrors;

[0045] FIG. 16A is a schematic diagram of a detection system having a splice connection;

[0046] FIG. 16B is another schematic diagram of a splice connection for a detection system;

[0047] FIG. 17 is a schematic diagram of a detection system including an optical amplifier;

[0048] FIG. 18 is a schematic diagram of a detection system further configured for communication; and

[0049] FIG. 19 is a schematic illustration of a combined detection system and suppression system.

[0050] The detailed description explains embodiments of the present disclosure, together with advantages and features, by way of example with reference to the drawings.

DETAILED DESCRIPTION

[0051] Referring now to the FIGS., a system 20 for detecting one or more conditions or events within a design-

ated area is illustrated. The detection system 20 may be able to detect one or more hazardous conditions, including but not limited to the presence of smoke, fire, temperature, flame, or any of a plurality of pollutants, combustion products, or chemicals. Alternatively, or in addition, the detection system 20 may be configured to perform monitoring operations of people, lighting conditions, or objects. In an embodiment, the system 20 may operate in a manner similar to a motion sensor, such as to detect the presence of a person, occupants, or unauthorized access to the designated area for example. The conditions and events described herein are intended as an example only, and other suitable conditions or events are within the scope of the disclosure.

[0052] The detection system 20 uses light to evaluate a volume for the presence of a condition. In this specification, the term “light” means coherent or incoherent radiation at any frequency or a combination of frequencies in the electromagnetic spectrum. In an example, the photoelectric system uses light scattering to determine the presence of particles in the ambient atmosphere to indicate the existence of a predetermined condition or event. In this specification, the term “scattered light” may include any change to the amplitude/intensity or direction of the incident light, including reflection, refraction, diffraction, absorption, and scattering in any/all directions. In this example, light is emitted into the designated area; when the light encounters an object (a person, smoke particle, or gas molecule for example), the light can be scattered and/or absorbed due to a difference in the refractive index of the object compared to the surrounding medium (air). Depending on the object, the light can be scattered in all different directions. Observing any changes in the incident light, by detecting light scattered by an object for example, can provide information about the designated area including determining the presence of a predetermined condition or event.

[0053] In its most basic form, as shown in FIG. 1, the detection system 20 includes a single fiber optic cable 28 with at least one fiber optic core. The term fiber optic cable 28 includes any form of optical fiber. As examples, an optical fiber is a length of cable that is composed of one or more optical fiber cores of single-mode, multimode, polarization maintaining, photonic crystal fiber or hollow core. A node 34 is located at the termination point of a fiber optic cable 32 and is inherently included in the definition of a fiber optic cable 28. The node 34 is positioned in communication with the ambient atmosphere. A light source 36, such as a laser diode for example, and a light sensitive device 38, such as a photodiode for example, are coupled to the fiber optic cable 28. A control system 50 of the detection system 20, discussed in further detail below, is utilized to manage the detection system operation and may include control of components, data acquisition, data processing and data analysis.

[0054] As shown in FIG. 1A, the light from the light source is transmitted through the node 34 to the surrounding area, illustrated schematically at 21. The light 21 interacts with one or more particles indicative of a condition, illustrated schematically at 22, and is reflected or transmitted back to the node 34, illustrated schematically at 23. A comparison of the light provided to the node 34 and/or changes to the light reflected back to the light sensitive device 38 from the node 34 will indicate whether or not changes in the atmosphere are present in the ambient atmosphere adjacent the node 34 that are causing the scattering of

the light. The scattered light as described herein is intended to additionally include reflected, transmitted, and absorbed light. Although the detection system 20 is described as using light scattering to determine a condition or event, embodiments where light obscuration, absorption, and fluorescence is used in addition to or in place of light scattering are also within the scope of the disclosure.

[0055] In another embodiment, the detection system 20 can include a plurality of nodes 34. For example, as illustrated in FIG. 2A, a plurality of fiber optic cables 28 and corresponding nodes 34 are each associated with a distinct light sensitive device 38. In embodiments where an individual light sensitive device 38 is associated with each node 34, as shown in FIG. 2A, the signal output from each node 34 can be monitored. Upon detection of a predetermined event or condition, it will be possible to localize the position of the event because the position of each node 34 within the system 20 is known. Alternately, as shown in FIG. 2B, a plurality of fiber optic cables 28, may be coupled to a single light sensitive device.

[0056] In embodiments where a single light sensitive device 38 is configured to receive scattered light from a plurality of nodes 34, the control system 50 is able to localize the scattered light, i.e. identify the scattered light received from each of the plurality of nodes 34. In an embodiment, the control system 50 uses the position of each node 34, specifically the length of the fiber optic cables 28 associated with each node 34 and the corresponding time of flight (i.e. the time elapsed between when the light was emitted by the light source 36 and when the light was received by the light sensitive device 38), to associate different parts of the light signal with each of the respective nodes 34 that are connected to that light sensitive device 38. Alternatively, or in addition, the time of flight may include the time elapsed between when the light is emitted from the node and when the scattered light is received back at the node. In such embodiments, the time of flight provides information regarding the distance of the object relative to the node.

[0057] In an embodiment, illustrated in the cross-section of the fiber optic cable shown in FIG. 3, two substantially identical and parallel light transmission fiber cores 40, 42 are included in the fiber optic cable 28 and terminate at the node 34. However, it should be understood that embodiments where the fiber optic cable 28 includes only a single fiber core, or more than two cores are also contemplated herein. The light source 36 may be coupled to the first fiber core 40 and the light sensitive device 38 may be coupled to the second fiber core 42, for example near a first end of the fiber optic cable 28. The light source 36 is selectively operable to emit light, which travels down the first fiber core 40 of the fiber optic cable 28 to the node 34. At the node 34, the emitted light is expelled into the adjacent atmosphere. The light is scattered and transmitted back into the node 34 and down the fiber cable 28 to the light sensitive device 38 via the second fiber core 42.

[0058] With reference now to FIG. 4A, in more complex embodiments, the detection system 20 includes a fiber harness 30 having a plurality of fiber optic cables 28 bundled together. It should be noted that a fiber harness 30 can also be only a single fiber optic cable 28. In an embodiment, a plurality of fiber cores 40, 42 are bundled together at a location to form a fiber harness backbone 31 with the ends of the fiber optic cables 28 being separated (not included in

the bundled backbone) to define a plurality of fiber optic branches 32 of the fiber harness 30. As shown, the plurality of fiber cores 40, 42 branch off to form a plurality of individual fiber branches 32, each of which terminates at a node 34. In the non-limiting embodiments of FIGS. 4A and 4B, the fiber harness 30 additionally includes an emitter leg 33 and a receiver leg 35 associated with the fiber branches 32. The emitter leg 33 may contain the first fiber cores 40 from each of the plurality of fiber branches 32 and the receiver leg 35 may contain all of the second fiber cores 42 from each of the fiber branches 32. The length of the fiber optic cores 40, 42 extending between the emitter leg 33 or the receiver leg 35 and the node 34 may vary in length such that the branches 32 and corresponding nodes 34 are arranged at various positions along the length of the fiber harness backbone 31. In an embodiment, the positions of the nodes 34 may be set during manufacture, or at the time of installation of the system 20.

[0059] Alternatively, the fiber harness 30 may include a fiber optic cable (not shown) having a plurality of branches 32 integrally formed therewith and extending therefrom. The branches 32 may include only a single fiber optic core. The configuration, specifically the spacing of the nodes 34 within a fiber harness 30 may be substantially equidistant, or may vary over the length of the harness 30. In an embodiment, the positioning of each node 34 may correlate to a specific location within the designated area.

[0060] With reference now to FIG. 5, the detection system 20 may additionally include a plurality of fiber harnesses 30. In the illustrated, non-limiting embodiment, a distinct light sensitive device 38 is associated with each of the plurality of fiber harnesses 30. However, embodiments where a single light sensitive device 38 is coupled to the plurality of fiber harnesses 30 are also contemplated here. In addition, a single light source 36 may be operably coupled to the plurality of light transmission fiber cores 40 within the plurality of fiber harnesses 30 of the system 20. Alternatively, the detection system 20 may include a plurality of light sources 36, each of which is coupled to one or more of the plurality of fiber harnesses 30.

[0061] The detection system 20 may be configured to monitor a predetermined area such as a building. The detection system 20 may be especially utilized for predetermined areas having a crowded environment, such as a server room, as shown in FIG. 6 for example. Each fiber harness 30 may be aligned with one or more rows of equipment 46, and each node 34 therein may be located directly adjacent to one of the towers 48 within the rows 46. In addition, nodes may be arranged so as to monitor specific enclosures, electronic devices, or machinery. Positioning of the nodes 34 in such a manner allows for earlier detection of a condition as well as localization, which may limit the exposure of the other equipment in the room to the same condition. In another application, the detection system 20 may be integrated into an aircraft, such as for monitoring a cargo bay, avionics rack, lavatory, or another confined region of the aircraft that may be susceptible to fires or other events.

[0062] The control system 50 of the detection system 20 is utilized to manage the detection system operation and may include control of components, data acquisition, data processing and data analysis. The control system 50, illustrated in FIG. 7, includes at least one light sensitive device 38, at least one light source, 36, and a control unit 52, such as a

computer having one or more processors **54** and memory **56** for implementing an algorithm **58** as executable instructions that are executed by the processor **54**. The instructions may be stored or organized in any manner at any level of abstraction. The processor **54** may be any type of processor, including a central processing unit (“CPU”), a general purpose processor, a digital signal processor, a microcontroller, an application specific integrated circuit (“ASIC”), a field programmable gate array (“FPGA”), or the like. Also, in some embodiments, memory **56** may include random access memory (“RAM”), read only memory (“ROM”), or other electronic, optical, magnetic, or any other computer readable medium for storing and supporting processing in the memory **56**. In addition to being operably coupled to the at least one light source **36** and the at least one light sensitive device **38**, the control unit **52** may be associated with one or more input/output devices **60**. In an embodiment, the input/output devices **60** may include an alarm or other signal, or a fire suppression system which are activated upon detection of a predefined event or condition. It should be understood herein that the term alarm, as used herein, may indicate any of the possible outcomes of a detection.

[0063] The processor **54** may be coupled to the at least one light source **36** and the at least one light sensitive device **38** via connectors. The light sensitive device **38** is configured to convert the scattered light received from a node **34** into a corresponding signal receivable by the processor **54**. In an embodiment, the signal generated by the light sensing device **38** is an electronic signal. The signal output from the light sensing device **38** is then provided to the control unit **52** for processing using an algorithm to determine whether a predefined condition is present.

[0064] The signal received by or outputted from the light sensitive device(s) **38** may be amplified and/or filtered, such as by a comparator (not shown), to reduce or eliminate irrelevant information within the signal prior to being communicated to the control unit **52** located remotely from the node **34**. In such embodiments, the amplification and filtering of the signal may occur directly within the light sensing device **38**, or alternatively, may occur via one or more components disposed between the light sensing device **38** and the control unit **52**. The control unit **52** may control the data acquisition of the light sensitive device **38**, such as by adjusting the gain of the amplifier, the bandwidth of filters, sampling rates, the amount of timing and data buffering for example.

[0065] With reference now to FIG. **8**, in an embodiment of the system **20**, the light sensitive device **38** may include one or more Avalanche Photodiode (APD) sensors **64**. For example, an array **66** of APD sensors **64** may be associated with the one or more fiber harnesses **30**. In an embodiment, the number of APD sensors **64** within the sensor array **66** is equal to or greater than the total number of fiber harnesses **30** operably coupled thereto. However, embodiments where the total number of APD sensors **64** within the sensor array **66** is less than the total number of fiber harnesses **30** are also contemplated herein.

[0066] Data representative of the output from each APD sensor **64** in the APD array **66** is periodically taken by a switch **68**, or alternatively, is collected simultaneously. The data acquisition **67** collects the electronic signals from the APD and associates the collected signals with metadata. The metadata as an example can be time, frequency, location or node. In an example, the electronic signals are from the APD

are synchronized to the laser modulation such that the electrical signals are collected for a period of time that starts when the laser is pulsed to several microseconds after the laser pulse. The data will be collected and processed by the processor **54** to determine whether any of the nodes **34** indicates the existence of a predefined condition or event. In an embodiment, only a portion of the data outputted by the sensor array **66**, for example the data from a first APD sensor **64** associated with a first fiber harness **30**, is collected. The switch **68** is therefore configured to collect information from the various APD sensors **64** of the sensor array **66** sequentially. While the data collected from a first APD sensor **64** is being processed to determine if an event or condition has occurred, the data from a second APD **66** of the sensor array **66** is collected and provided to the processor **54** for analysis. When a predefined condition or event has been detected from the data collected from one of the APD sensors **64**, the switch **68** may be configured to provide additional information from the same APD sensor **64** to the processor **54** to track the condition or event.

[0067] A method of operation **100** of the detection system **20** is illustrated in FIG. **9**. The control unit **52** operably coupled to the light source **36** is configured to selectively energize the light source **36**, as shown in block **102**, and to emit light to a fiber harness **30** coupled thereto as shown in block **104**. Based on the desired operation of the detection system **20**, the control unit **52** may vary the intensity, duration, repetition, frequency, or other properties, of the light emitted. As the light travels down the first fiber core **40** of the at least one fiber optic branch **32**, all or a portion of the light is emitted at one or more nodes **34** of the fiber harness **30**. In block **106**, light is scattered in the predetermined area and transmitted back through the fiber optic branches **32** via the second fiber cores **42**. The scattered light may include one or more of scattered light within the atmosphere adjacent the node and scattered light that reflects from an interior of the fiber optic branch **32**. The scattered light is transmitted to the at least one light sensing device **38** in block **108**. As shown in block **110**, the light sensing device **38** generates a signal in response to the scattered light received by each node **34**, and provides that signal to the control unit **52** for further processing.

[0068] Using the algorithm **58** executed by the processor **54**, each of the signals representing the scattered light received by the corresponding nodes **34** are evaluated to determine whether the light at the node **34** is indicative of a predefined condition, such as smoke for example. With reference to FIG. **10**, a schematic diagram illustrating an example of a flow path for processing the signals generated by each of the nodes **34** is illustrated. As shown, the signal indicative of scattered light **69** is parsed, shown at block **70**, into a plurality of signals based on their respective originating node **34**. In the illustrated, non-limiting embodiment, background signals, illustrated schematically at **72**, are subtracted from the data before the pulse features are evaluated for each of the individual signals. Through integration, pulse compression, and/or feature extraction, shown at block **74**, one or more characteristics or features (pulse features) of the signal may be determined. Examples of such features include, but are not limited to, a peak height, an area under a curve defined by the signal, statistical characteristics such as mean, variance, and/or higher-order moments, correlations in time, frequency, space, and/or combinations thereof,

and empirical features as determined by deep learning, dictionary learning, and/or adaptive learning and the like.

[0069] In an embodiment, the time of flight record is parsed and features are extracted. The time of flight record can cover a period of time. For example, a time of flight record can record light intensity over 0.001-1,000,000 nanoseconds, 0.1-100,000 nanoseconds, or 0.1-10,000 microseconds. The features extracted from the signal can include, but are not limited to height, full width at half maximum, signal pick up time, signal drop off time, group velocity, integration, rate of change, mean, and variance for example.

[0070] Through application of the data processing, illustrated schematically at block 76, the features may then be further processed by using, for example, smoothing, Fourier transforms or cross correlation. In an embodiment, the processed data is then sent to the detection algorithm at block 78 to determine whether or not the signal indicates the presence and/or magnitude of a condition or event at a corresponding node 34. This evaluation may be a simple binary comparison that does not identify the magnitude of deviation between the characteristic and a threshold. The evaluation may also be a comparison of a numerical function of the characteristic or characteristics to a threshold. The threshold may be determined a priori or may be determined from the signal. The determination of the threshold from the signal may be called background learning. Background learning may be accomplished by adaptive filtering, model-based parameter estimation, statistical modeling, and the like. In some embodiments, if one of the identified features does not exceed a threshold, the remainder of the detection algorithm is not applied in order to reduce the total amount processing done during the detection algorithm. In the event that the detection algorithm indicated the presence of the condition at one or more nodes 34, an alarm or other fire suppression system may, but need not be activated. It should be understood that the process for evaluating the data illustrated and described herein is intended as an example only and that other processes including some or all of the steps indicated in the FIG. are also contemplated herein.

[0071] The evaluation may also advantageously employ classifiers including those that may be learned from the signal via deep learning techniques including, but not limited to deep neural networks, convolutional neural networks, recursive neural networks, dictionary learning, bag of visual/depth word techniques, Support Vector Machine (SVM), Decision Trees, Decision Forests, Fuzzy Logic, and the like. The classifiers may also be constructed using Markov Model techniques, Hidden Markov Models (HMM), Markov Decision Processes (MDP), Partially Observable MDPs, Markov Decision Logic, Probabilistic Programming, and the like.

[0072] In addition to evaluating the signals generated from each node 34 individually, the processor 54 may additionally be configured to evaluate the plurality of signals or characteristics thereof collectively, such as through a data fusion operation to produce fused signals or fused characteristics. The data fusion operation may provide information related to time and spatial evolution of an event or predetermined condition. As a result, a data fusion operation may be useful in detecting a lower level event, insufficient to initiate an alarm at any of the nodes 34 individually. For example, in the event of a slow burning fire, the light signal generated by a small amount of smoke near each of the nodes 34 individually may not be sufficient to initiate an alarm. However, when the signals from the plurality of nodes 34 are reviewed

in aggregate, the increase in light returned to the light sensitive device 38 from multiple nodes 34 may indicate the occurrence of an event or the presence of an object not otherwise detected. In an embodiment, the fusion is performed by Bayesian Estimation. Alternatively, linear or non-linear joint estimation techniques may be employed such as maximum likelihood (ML), maximum a priori (MAP), non-linear least squares (NNLS), clustering techniques, support vector machines, decision trees and forests, and the like.

[0073] As illustrated and described above, the processor 54 is configured to analyze the signals generated by at least one light sensing device 38 relative to time. In another embodiment, the detection algorithm may be configured to apply one or more of a Fourier transform, Wavelet transform, space-time transform, Choi-Williams distribution, Wigner-Ville distribution and the like, to the signals to convert the signals from a temporal domain to a frequency domain. This transformation may be applied to the signals when the nodes 34 are being analyzed individually, when the nodes 34 are being analyzed collectively during a data fusion, or both.

[0074] The relationship between the light scattering and the magnitude or presence of a condition is inferred by measuring a signal's causality and dependency. As an example, the measure of a causality utilizes one or more signal features as an input and determines one or more outputs from a calculation of a hypothesis testing method, foreground ratio, second derivative, mean or Granger Causality Test. Similarly, one or more signal features may be used as an input to evaluate the dependency of a signal. One or more outputs are selected from a calculation of a correlation, fast Fourier transform coefficients, a second derivative, or a window. The magnitude and presence of the condition is then based on the causality and dependency. The magnitude and presence of a condition may be calculated utilizing one or more evaluation approaches: a threshold, velocity, rate of change or a classifier. The detection algorithm may include utilizing the output from the calculation causality, dependency or both. This is used to indicate the presence of the condition at one or more nodes 34 and initiate a response.

[0075] Because the frequency of smoke varies within a small range, such as from about 0.01 Hz to about 10 Hz for example, evaluation of the signals with respect to frequency may effectively and accurately determine the presence of smoke within the predetermined space 82. The detection algorithm may be configured to evaluate the signals in a fixed time window to determine the magnitude of the frequency or the strength of the motion of the smoke. Accordingly, if the magnitude of a frequency component exceeds a predetermined threshold, the detection algorithm may initiate an alarm indicating the presence of a fire. In an embodiment, the predetermined threshold is about 10 Hz such that when the magnitude of the optical smoke frequency exceeds the threshold, smoke is present.

[0076] In an embodiment, the algorithm 58 is configured to distinguish between different events or conditions based on the rate of change in the light scattered by the atmosphere near the node 34 and received by one or more of the nodes 34 over time. With reference to FIGS. 11A and 11B, graphs of the signals recorded from a node 34 over time with respect to different events are illustrated. FIG. 11A indicates the change in the light signal received by a node 34 as a

person walks through the area being monitored by the node 34. As shown in the graph, the movement of a person appears as steps having varying magnitudes. FIG. 11B, which represents the detection of smoke from a smoldering fire, appears graphically as a much continuously changing signal having an accelerating increase in the change in light signal received by a node 34 over time. It should be understood that the graphs illustrated are examples only. Further, each predefined event detectable by the detection system 20 may have one or more unique parameters associated therewith.

[0077] To reduce the noise associated with each signal, the light emitting device 36 may be modulated such that the device 36 is selectively operated to generate modulated light in a specific pattern. In an embodiment, the light within the pattern may vary in intensity, width, frequency, phase, and may comprise discrete pulses or may be continuous. The specific pattern of light may be designed to have desirable properties such as a specific autocorrelation with itself or cross-correlation with a second specific pattern. When the light is emitted in a specific pattern, the light scattered back to a corresponding light sensing device 38 should arrive in the substantially same pattern. Use of one or more specific and known patterns provides enhanced processing capabilities by allowing for the system 20 to reduce overall noise. This reduction in noise when combined with the signal processing may result in an improved signal to noise ratio and the total number of false events or conditions detected will decrease. Alternatively, or in addition, the device sensitivity may be improved thereby increasing the limits of the detection system 20. Similarly, by cross-correlating one or more second patterns, specific causes of transmitted or reflected signals may be distinguished, e.g. by Bayesian estimation of the respective cross-correlations of the received signal with the one or more second patterns.

[0078] In addition, modulation of the light signal emitted by the light source 36 may provide improved detection by determining more information about the event or condition causing the scatter in the light signal received by the node 34. For example, such modulation may allow the system 20 to more easily distinguish between a person walking through the designated area adjacent a node, as shown in FIG. 11A, and a smoldering fire adjacent the node 34.

[0079] Referring now to FIG. 12, in some embodiments the system 20 includes one or more optical enhancement devices 80, such as a bandpass filter, a polarizer, an antireflective coating, a wave plate, and/or other optical features to reduce interference from non-event signals, or other non-desired signals, such as ambient light from either sunlight or lighting in the space, or from solid objects in the predetermined space 82. Further, the optical enhancement devices 80 may be utilized to reduce undesired wavelengths and/or intensities transmitted from the light source 36. The optical enhancement 80 is placed in the system 20 downstream of the light source 36, in some embodiments a laser diode, and upstream of the light sensitive device 38, in some embodiments the photodiode. The optical enhancement device 80 is placed so that light scattered and reflected back to the light sensitive device 38 is passed through the optical enhancement device 80 to filter or differentiate events or other conditions to be sensed from other signals due to, for example, ambient light, solid objects, bugs, dust, or water vapor.

[0080] As shown in FIG. 12, in some embodiments the optical enhancement 80 is located at the light sensitive device 38 and/or is a component of, integral to or embedded within the light sensitive device 38. Further, the light sensitive device 38 may be configured such that the optical enhancement device 80 is readily removable and/or replaceable with another optical enhancement 80 to filter or disseminate different conditions in the scattered/reflected signal.

[0081] While in the embodiment of FIG. 12, the optical enhancement device 80 is located at the light sensitive device 38 or embedded in the light sensitive device 38, in other embodiments the optical enhancement device 80 is located at other locations, such as at the node 34 as shown in FIG. 13. This allows for node-specific placement of optical enhancement devices 80 such that different optical enhancement devices 80 may be placed at different nodes 34. Further, in some embodiments, combinations of optical enhancement devices 80, such as combinations of bandpass filters and polarizers, may be utilized to filter or disseminate certain conditions of the scattered/reflected light. Further, in systems 20 where the nodes 34 include two or more cores 40, 42, optical enhancements 80 may be located at an individual core 40, 42 or at two or more of the cores 40, 42.

[0082] Referring now to FIG. 14, in some embodiments the system 20 includes focusing or expanding optical elements to increase range, sensitivity or field of view of the detection system 20 in detecting smoke/gas or other conditions or events. A focusing optical element can be placed at the node or between the control system and fiber harness to increase range and sensitivity by converging or collimating light. Also, an expanding optical element can be placed in similar locations to increase the field of view of the node by diverging the light. By way of example, optical elements may include mirrors, focusing lenses, diverging lenses, and diffusers, along with the integration of antireflective coatings on the optical elements or components thereof.

[0083] As shown in FIG. 14, the optical elements may be one or more lenses 84 located at the node 34. The lens 84 reduces divergence of the outgoing beam transmitted from the light source 36, while also increasing the amount of scattered light accepted by the node 34 for transmission to the light sensitive device 38. In some embodiments, the lens 84 is fused to the end of cores 40, 42 at the node 34 to reduce scattering of the light off of the lens 84 face, thereby enhancing light collection efficiency of the node 34. Further, in some embodiments, cores 40, 42 may have lensed and tapered fibers, which do not require fusing and function as a lens 84. In other embodiments, the lens 84 may be configured to reduce the scattering of light off of the lens face. Further, the lens 84 may include beam steering features, such as a solid state material which is utilized to change the refractive index of incident light to steer the light along the cores 40, 42. The beam steering feature may also be a photonic integrated circuit, which utilizes patterned silicon to control the directional emission of light.

[0084] Referring now to FIG. 15, in some embodiments the optical elements may include a parabolic mirror 86 located at the node 34. The parabolic mirror 86 is located off-angle relative to a node axis 88. As with the lens 84, the parabolic mirror 86 reduces divergence of the outgoing beam transmitted from the light source 36, while also increasing an amount of scattered light accepted by the node 34 for transmission to the light sensitive device 38. In some

embodiments, the parabolic mirror **86** is configured to rotate about a rotational axis during operation of the system **20** to further increase a coverage area of the node **34**.

[0085] In some embodiments, both lens **84** and mirror **86** may be utilized at node **34**. Further, while in the embodiments illustrated in FIGS. **14** and **15** optics are utilized at each node **34**, in other embodiments, optics may be utilized only at selected nodes **34** to provide their benefits to the selected nodes **34**, such as increasing detection range at selected nodes **34** due to, for example, constraints in placement of nodes **34** in the protected space. In other embodiments, the optical elements can be placed at the light source **36** or light sensitive device to enhance the detection system **50**.

[0086] In addition to smoke or dust, the system **20** may be utilized to monitor or detect pollutants such as volatile organic compounds (VOC's), particle pollutants such as PM2.5 or PM10.0 particles, biological particles, and/or chemicals or gases such as H₂, H₂S, CO₂, CO, NO₂, NO₃, or the like. Multiple wavelengths may be transmitted by the light source **36** to enable simultaneous detection of smoke, as well as individual pollutant materials. For example, a first wavelength may be utilized for detection of smoke, while a second wavelength may be utilized for detection of VOC's. Additional wavelengths may be utilized for detection of additional pollutants, and using multiple wavelength information in aggregate may enhance sensitivity and provide discrimination of gas species from false or nuisance sources. In order to support multiple wavelengths, one or more lasers may be utilized to emit several wavelengths. Alternatively, the control system can provide selectively controlled emission of the light. Utilization of the system **20** for pollutant detection can lead to improved air quality in the predetermined space **82** as well as improved safety.

[0087] In some embodiments, such as shown in FIG. **16A**, the fiber optic branches **32** are each operably connected to the fiber harness backbone **31**, which may only include a single fiber optic core, via a coupling **132**. In some embodiments, the coupling **132** is one of a splice connection, a fused connection or a solid state switching device. Utilizing couplings **132** allows nodes **34** to be added to the fiber harness **30** after installation of the fiber harness **30**, or removal or relocation of the nodes **34** once the fiber harness **30** is installed. The couplings **132** therefore increase flexibility of the fiber harness **30** and the system **20**.

[0088] In another embodiment, such as shown in FIG. **16B**, a first fiber optic core **40** is operably coupled to a first node **34**, while a second node **34** is operably coupled to a second fiber optic core **42**. In such embodiments, the first fiber optic core **40** is utilized for transmission of light from the light source **36**, while the second fiber optic core **42** receives scattered light and conveys the scatter light to the light sensitive device **38**. In some embodiments, a first coupling **132a** coupling the first fiber optic core **40** to the first node **34** is the same as a second coupling **132b** coupling the second fiber optic core **42** to the second node **34**, while in other embodiment the first coupling **132a** is different from the second coupling **132b**.

[0089] Further, as an alternative to or in addition to the splice connection, fused connections, one or more solid state switching devices, optical amplifiers **96** may be placed along the fiber harness **30** to amplify signals proceeding through the fiber harness **31**. The optical amplifier **96** may be located, for example as shown in FIG. **17**, between nodes **34**, or

between the light detection device **38** and the fiber harness **30**. Further, in some embodiments, coupling **132** may be located at other locations along the fiber harness **30**, for example, between the fiber harness **30** and the light source **36**, and/or between the fiber harness **30** and the light sensitive device **38**.

[0090] Referring now to FIG. **18**, the control system **50** is configured for multiple inputs and/or multiple outputs for communication of information through the fiber optic cables **28** and the nodes **34**. In some embodiments, the multiple inputs and outputs may include an internet connection **140**, a building network or management system **142**, and/or a fire panel **134** of the building or enclosed space. The fire panel **134** is configured for communications with, for example, a fire department, and/or is configured to transmit alarms through the building or space in the event of detection of smoke, fire or other substance by the system **20**. In the embodiment shown in FIG. **18**, the fiber optic cables **28** are further utilized for the communication of alarms, alerts and other information, such as system diagnostic information through the building. The control system **50** is able to both measure the condition in the predetermined area **82** and provide communication. For example, once the control system **50** determines that a condition is present based on detection signals received from one or more nodes **34**, the control system **50** transmits one or more alarm signals from the fire panel **134** along fiber optic cables **28** to one or more alarm units **138** in the building or space which initiate an alarm or alert based on the received alarm signals. The control system **50** is able to do this in a fiber optic harness **30** by combining frequency and amplitude modulation of the light. In some embodiments, the alert or alarm is an audible sound or sounds, while in other embodiments the alert or alarm is a light, or a combination of light and sound. Further, the control system **50** may be configured to send and/or receive communication through the fiber optic cables **28** and the nodes **34** to communicate with one or more building infrastructure or local devices in the space via modulated light transmitted along the cables **32**. In some embodiments, this communication is via Li-Fi protocol.

[0091] Referring now to FIG. **19**, shown is an enclosure **122**, for example, a server housing, with one or more electronic components **124** located therein. A detection system **20** is installed in the enclosure **122**, along with a suppression system **126**. The suppression system **126** may include, for example, a suppressant supply **128** and one or more suppressant outlets **130** located at, for example, nodes **34** of the detection system **20**. The detection system **20**, the suppression system **126** and the one or more electronic components **124** are connected to the control unit **52** of the detection system **20**. In the event of detection of fire or smoke at a node **34** of the detection system **20**, the control unit **52** triggers the suppression system **126** to activate the suppressant outlet **130** at the node **34** location to provide localized suppression in the enclosure **122**. Further, the control unit **52** may command powering down of electronic components **124** in the node **34** region to prevent further damage to the particular electronic components **124**. Localized detection and suppression such as described herein via detection system **20** and suppression system **126**, provides protection of electronic components **124** from fire and smoke, while localizing suppression to protect such components not subjected to fire and smoke from exposure to

suppressant, reducing damage to those components and further reducing cost and expense of suppressant cleanup after an event.

[0092] While the disclosure has been described in detail in connection with only a limited number of embodiments, it should be readily understood that the disclosure is not limited to such disclosed embodiments. Rather, the invention can be modified to incorporate any number of variations, alterations, substitutions or equivalent arrangements not heretofore described, but which are commensurate with the spirit and scope of the disclosure. Additionally, while various embodiments of the disclosure have been described, it is to be understood that aspects of the disclosure may include only some of the described embodiments. Accordingly, the disclosure is not to be seen as limited by the foregoing description, but is only limited by the scope of the appended claims.

1. A detection system for measuring one or more conditions within a predetermined area comprising:
 - a fiber harness having at least one fiber optic cable for transmitting light, the at least one fiber optic cable defining a node arranged to measure the one or more conditions;
 - a control system operably coupled to the fiber harness such that scattered light associated with the node is transmitted to the control system, wherein the control system analyzes the scattered light to determine at least one of a presence and magnitude of the one or more conditions at the node; and
 - an optical element operably connected to the fiber harness or control system to alter or define the operational range or sensitivity of the node.
2. The system of claim 1, wherein the optical element is an expanding optical element.
3. The system according to claim 1, wherein the optical element is disposed at the node.
4. The system according to claim 1, wherein the optical element reduces divergence of an outgoing light and/or increases an amount of scattered light received by the node.
5. The system according to claim 1, wherein the optical element is a focusing lens.
6. The system according to claim 1, wherein the optical element is fused to the node.
7. The system of claim 1, wherein the optical element is disposed at the node and includes a shaped fiber.

8. The system according to claim 1, wherein the optical element is configured to reduce scattering of light off of a lens face.

9. The system according to claim 1, wherein the optical element includes beam steering features.

10. The system according to claim 1, wherein the optical element is a mirror disposed near the node.

11. The system according claim 10, wherein the mirror is positioned off-axis of the node and/or at an angle relative to a node axis.

12. The system according to claim 10, wherein the mirror is configured to move.

13. The system according to claim 1, wherein the one or more conditions includes the presence of one or more of smoke or fire in the predetermined area.

14. A method of measuring one or more conditions within a predetermined area comprising:

transmitting light along a fiber harness to a node of a fiber optic cable of the fiber harness, the node arranged to measure the one or more conditions;

receiving scattered light received by the node;

modifying a sensitivity of the node by utilizing an optical element; and

analyzing the scattered light associated with the node to determine at least one of the presence and magnitude of the condition within the predetermined area.

15. The method according to claim 14, further comprising modifying a range of the node by utilizing the optical element.

16. The method according to claim 14, further comprising receiving scattered light at the node via the optical element.

17. The method according to claim 14, further comprising modifying the divergence of an outgoing light and/or modifying an amount of scattered light received by the node by utilizing the optical element.

18. The method according to claim 14, wherein the optical element is a lens fused to or integrated into the fiber cable at the node.

19. The method according to claim 14, wherein the optical element is a mirror disposed at and/or near the node.

20. The method according claim 19, wherein the mirror is located off-axis of the node and/or at an angle relative to a node axis.

21. (canceled)

* * * * *