



(19) **United States**

(12) **Patent Application Publication**
Hayter et al.

(10) **Pub. No.: US 2020/0284780 A1**

(43) **Pub. Date: Sep. 10, 2020**

(54) **METHOD AND APPARATUS FOR PROVIDING DATA PROCESSING AND CONTROL IN A MEDICAL COMMUNICATION SYSTEM**

(71) Applicant: **Abbott Diabetes Care Inc.**, Alameda, CA (US)

(72) Inventors: **Gary Alan Hayter**, Oakland, CA (US); **Geoffrey V. McGarraugh**, San Rafael, CA (US); **Andrew H. Naegeli**, Walnut Creek, CA (US); **John Charles Mazza**, Long Beach, CA (US); **Benjamin Jay Feldman**, Berkeley, CA (US)

(73) Assignee: **Abbott Diabetes Care Inc.**, Alameda, CA (US)

(21) Appl. No.: **16/824,568**

(22) Filed: **Mar. 19, 2020**

Related U.S. Application Data

(63) Continuation of application No. 16/181,069, filed on Nov. 5, 2018, now Pat. No. 10,634,662, which is a continuation of application No. 15/796,274, filed on Oct. 27, 2017, now Pat. No. 10,119,956, which is a continuation of application No. 14/223,893, filed on Mar. 24, 2014, now Pat. No. 9,804,150, which is a continuation of application No. 13/567,038, filed on Aug. 4, 2012, now Pat. No. 8,682,615, which is a continuation of application No. 12/152,652, filed on May 14, 2008, now Pat. No. 8,239,166.

(60) Provisional application No. 60/917,837, filed on May 14, 2007.

Publication Classification

(51) **Int. Cl.**
G01N 33/49 (2006.01)
A61B 5/145 (2006.01)
A61B 5/1473 (2006.01)
A61B 5/1495 (2006.01)
G16H 20/10 (2006.01)
G16H 10/40 (2006.01)

(52) **U.S. Cl.**
CPC *G01N 33/49* (2013.01); *A61B 5/14532* (2013.01); *A61B 5/1473* (2013.01); *A61B 5/1495* (2013.01); *G16H 40/40* (2018.01); *G16H 10/40* (2018.01); *A61B 2560/0223* (2013.01); *A61B 2560/0252* (2013.01); *G16H 20/10* (2018.01)

(57) **ABSTRACT**

Methods for data processing and control for a medical communication system are provided, including determining a sensitivity value for each sensor of a batch of in vivo analyte sensors; determining a sensitivity variation for each sensor of the batch; determining a mean sensitivity based on the sensitivity value determined for each sensor of the batch when it is determined that the determined sensitivity variation does not exceed a tolerance threshold level; associating a sensor code with each sensor of the batch of in vivo analyte sensors when the mean sensitivity is within a predetermined sensitivity range, wherein the sensor code associated with each sensor is based on a characteristic of the associated sensor; and storing the sensor code associated with at least one sensor of the batch configured to generate signals corresponding to monitored analyte level in a memory of a data processing device associated with the sensor.

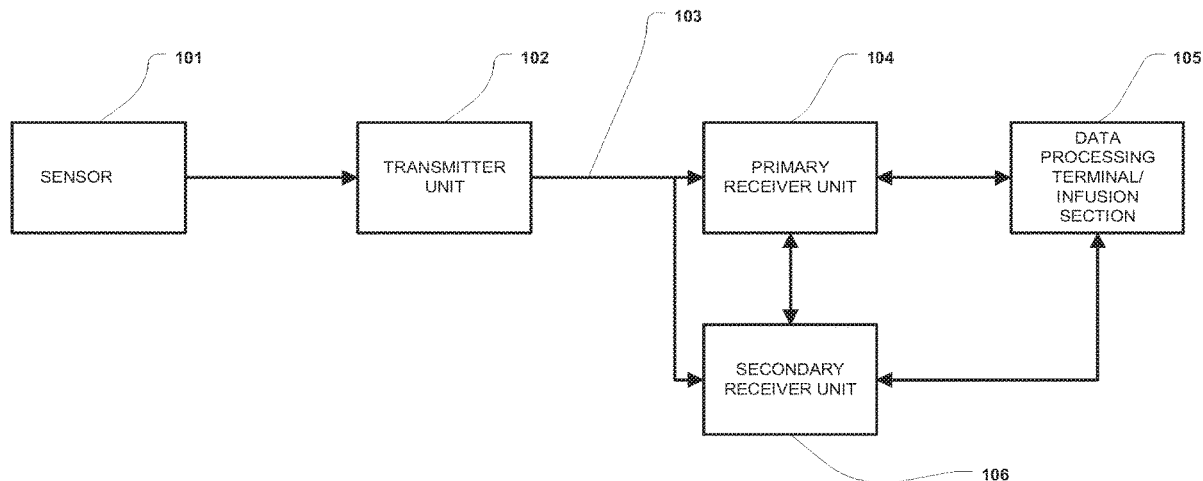

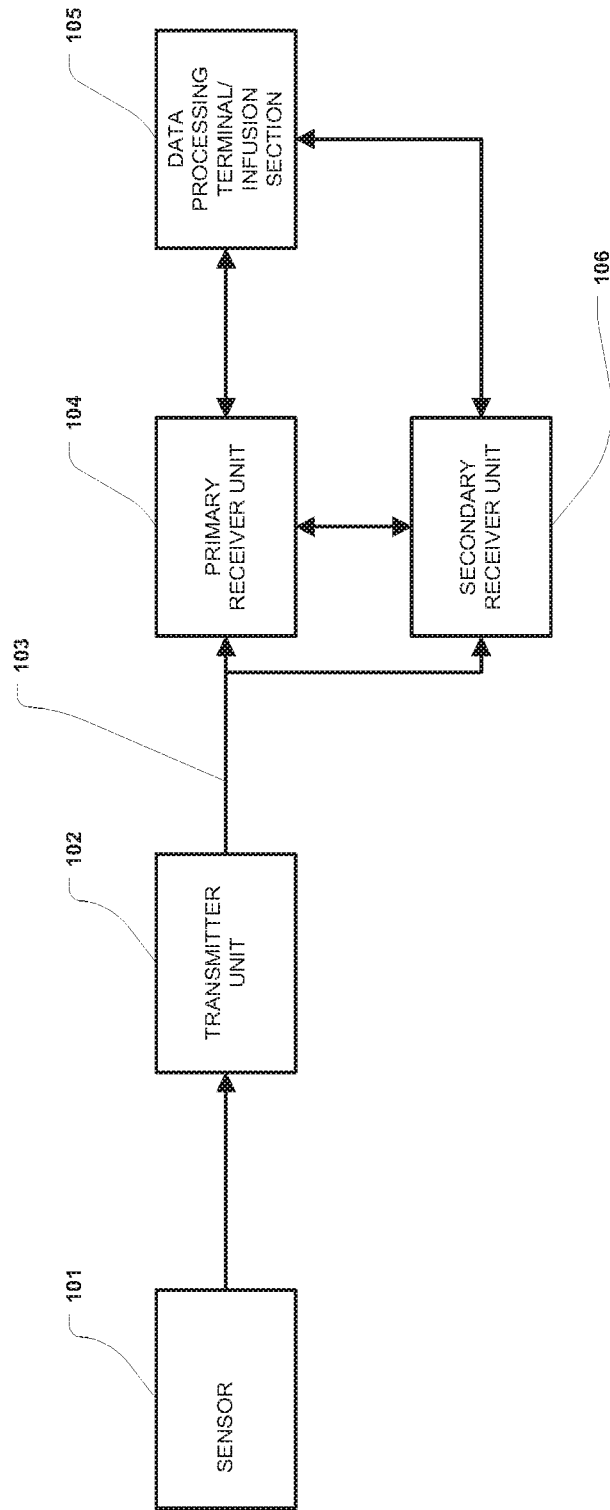

100

FIGURE 1

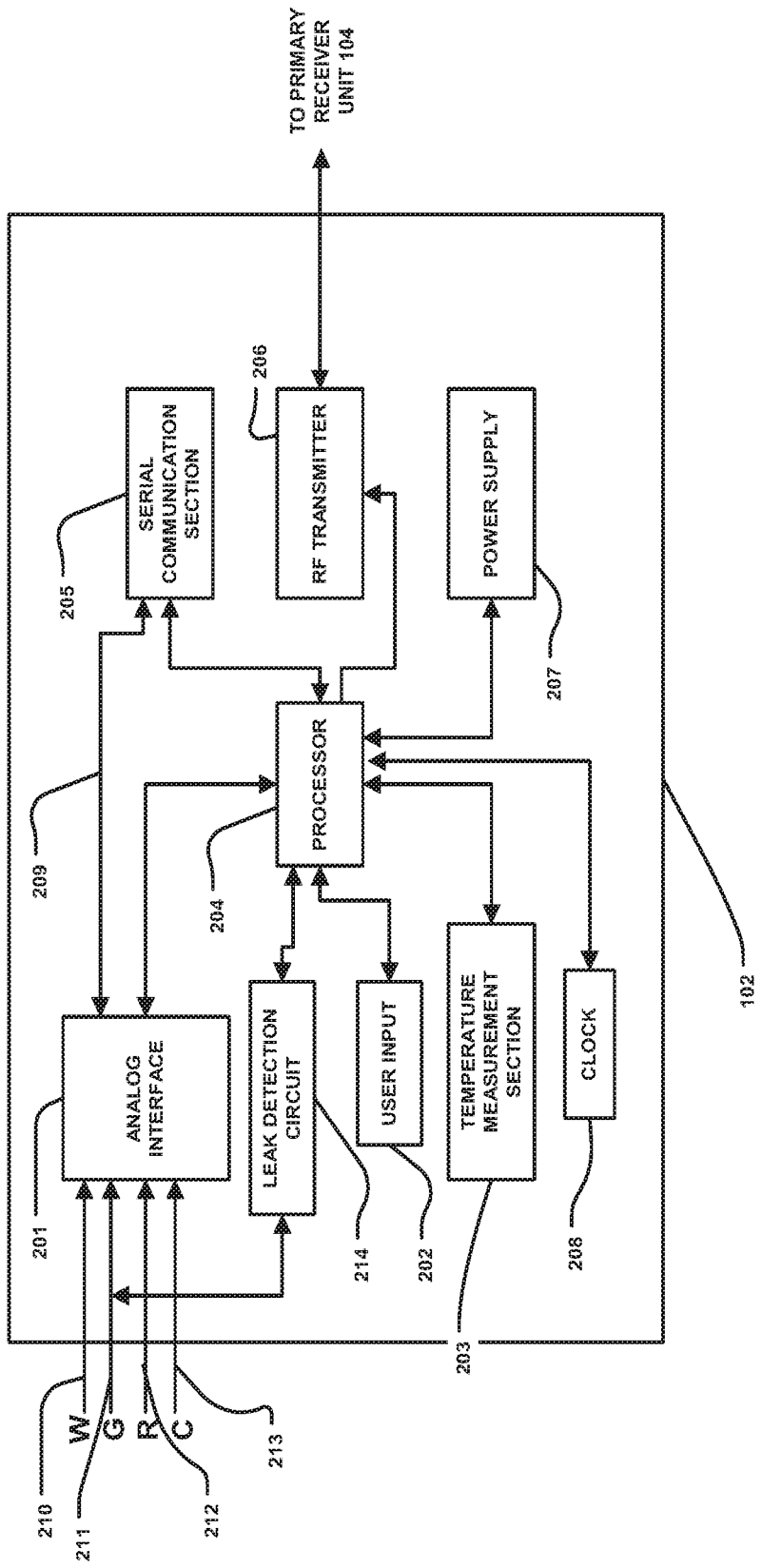

FIGURE 2

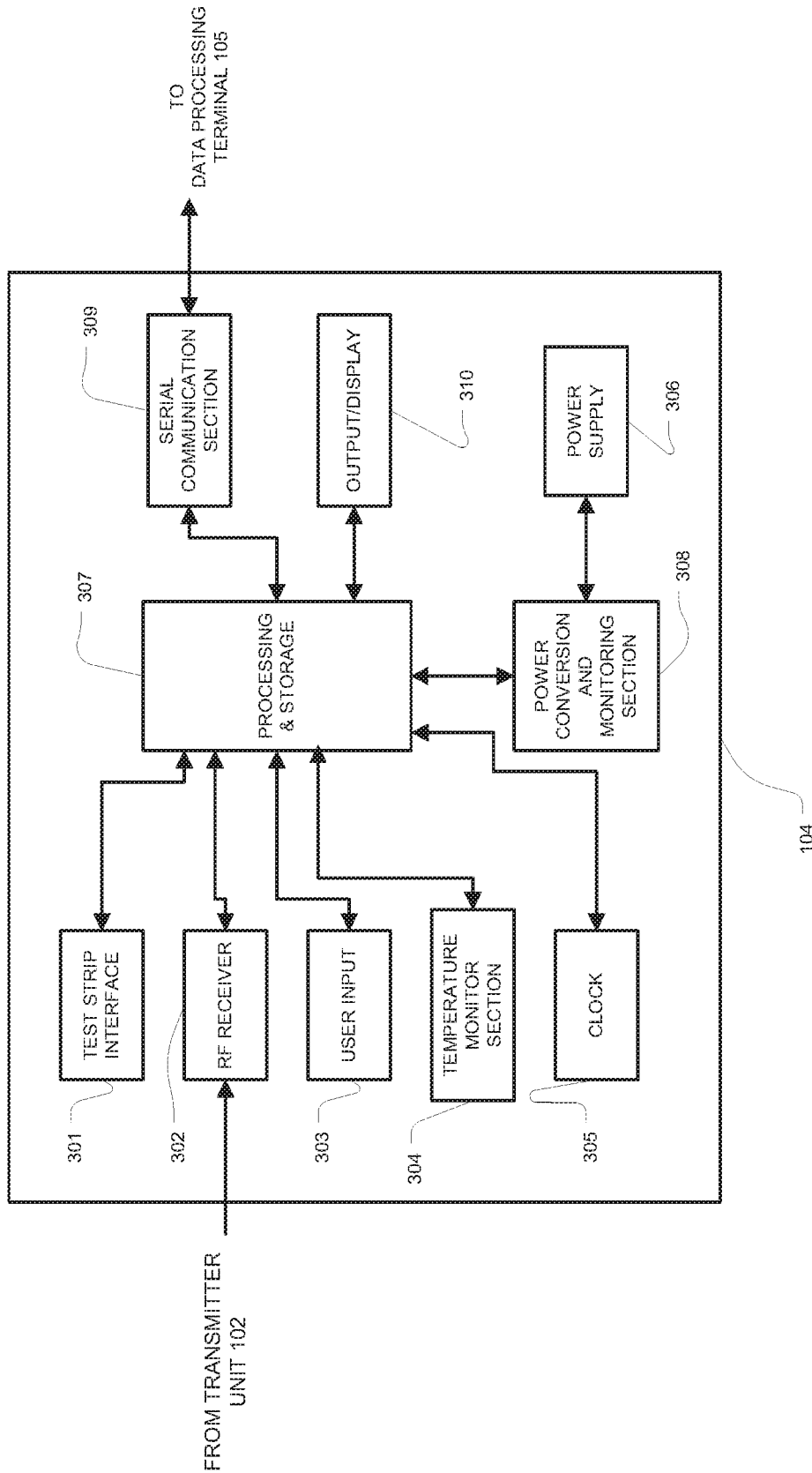

FIGURE 3

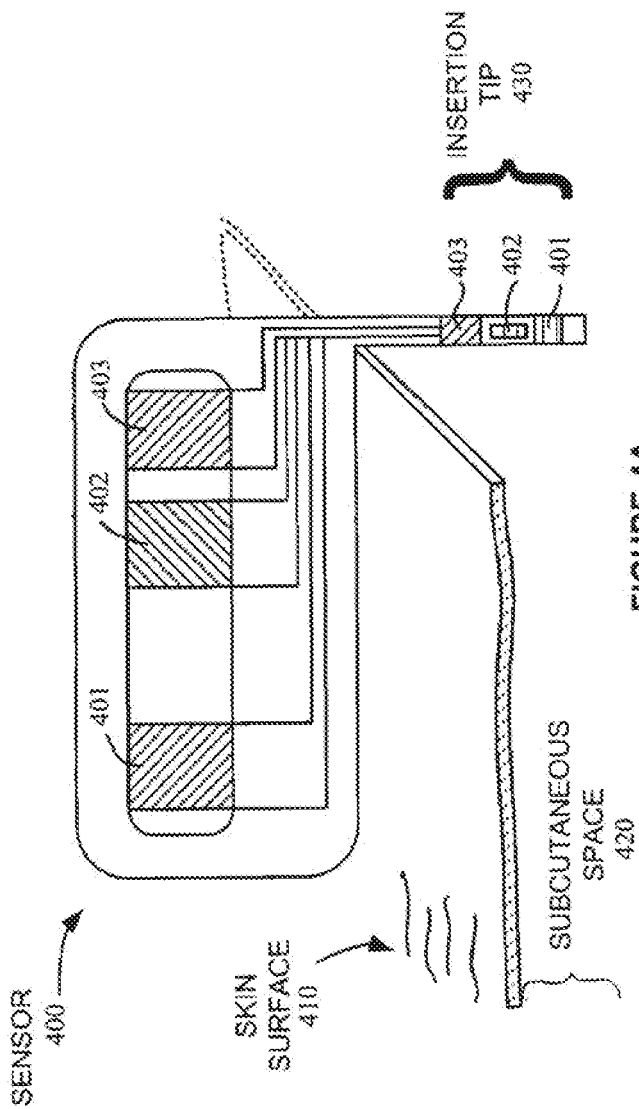

FIGURE 4A

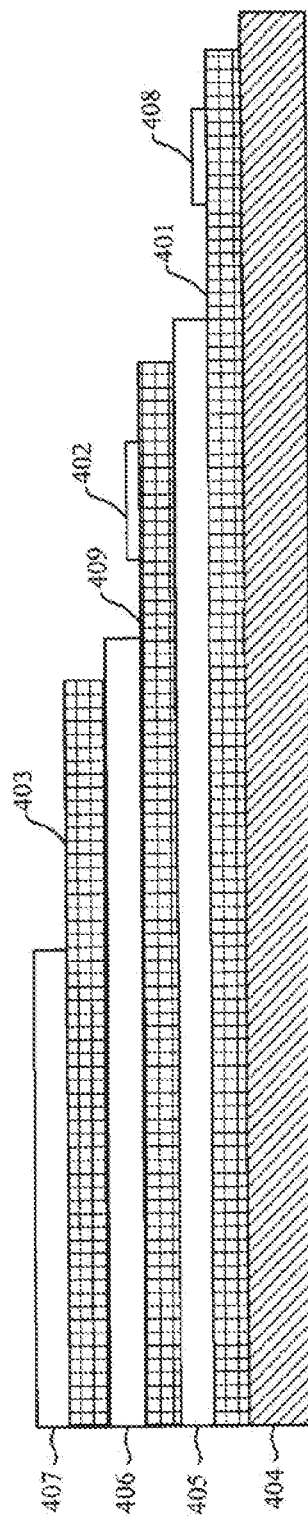

FIGURE 4B

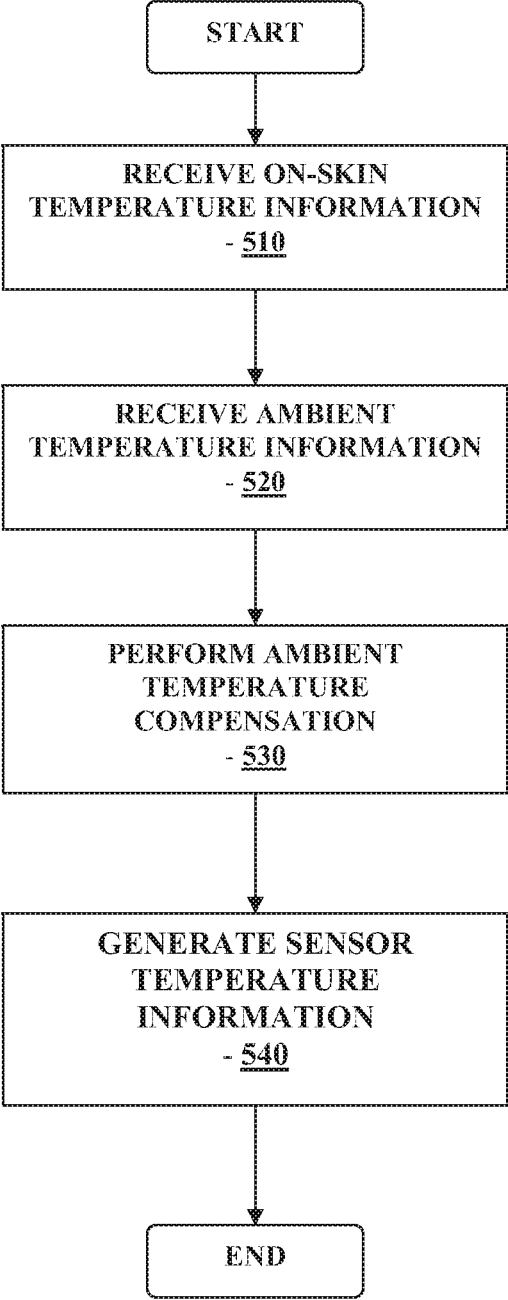

FIGURE 5

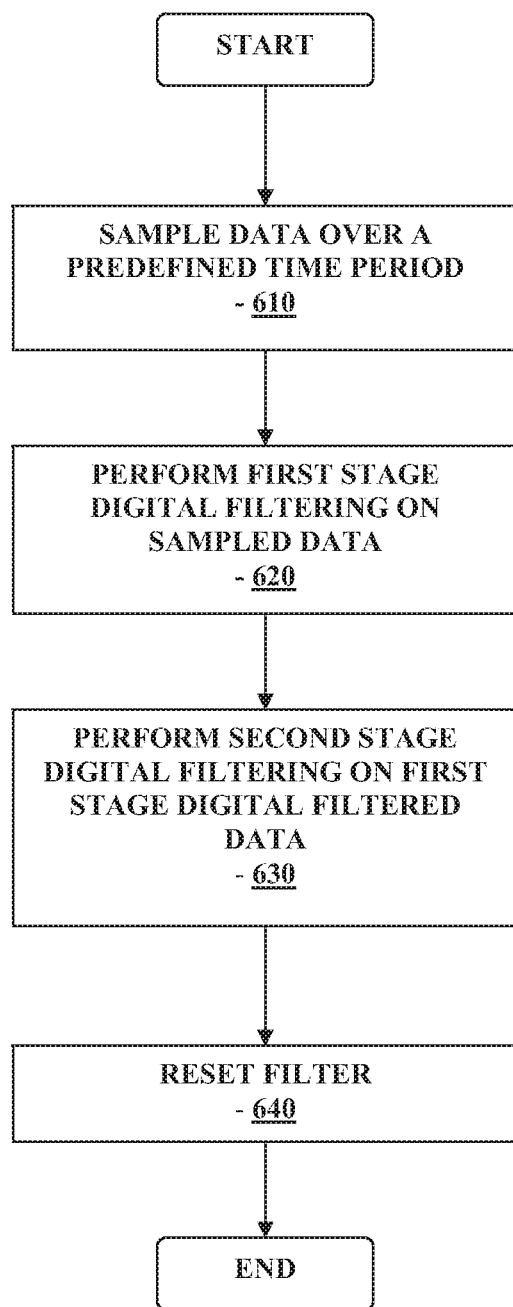

FIGURE 6

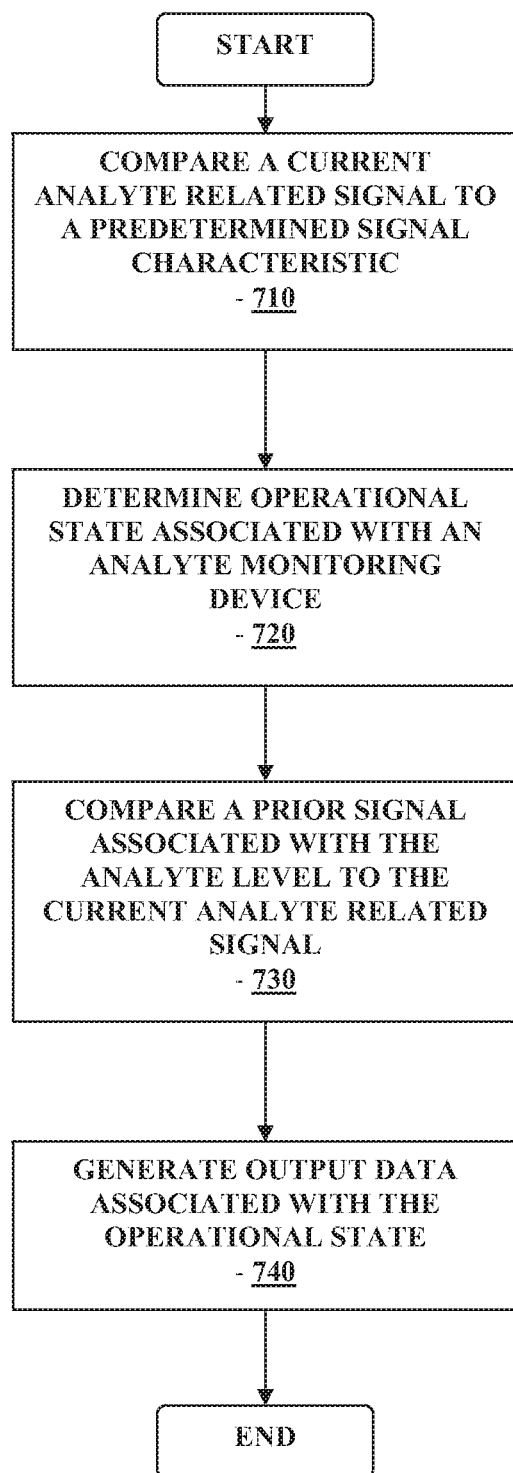

FIGURE 7

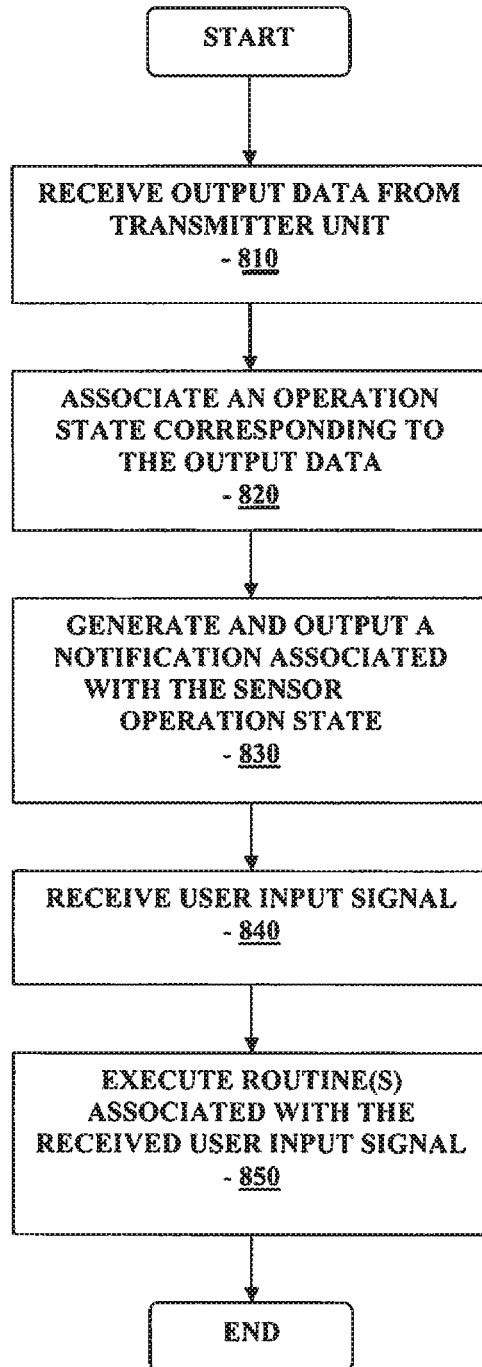

FIGURE 8

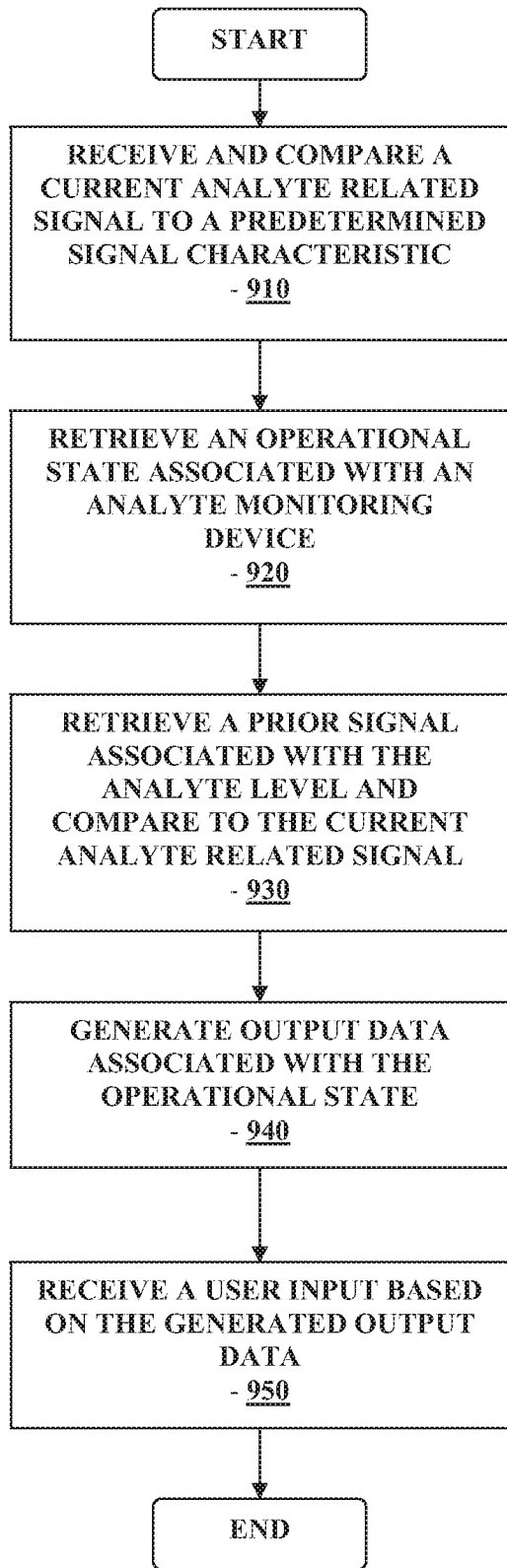

FIGURE 9

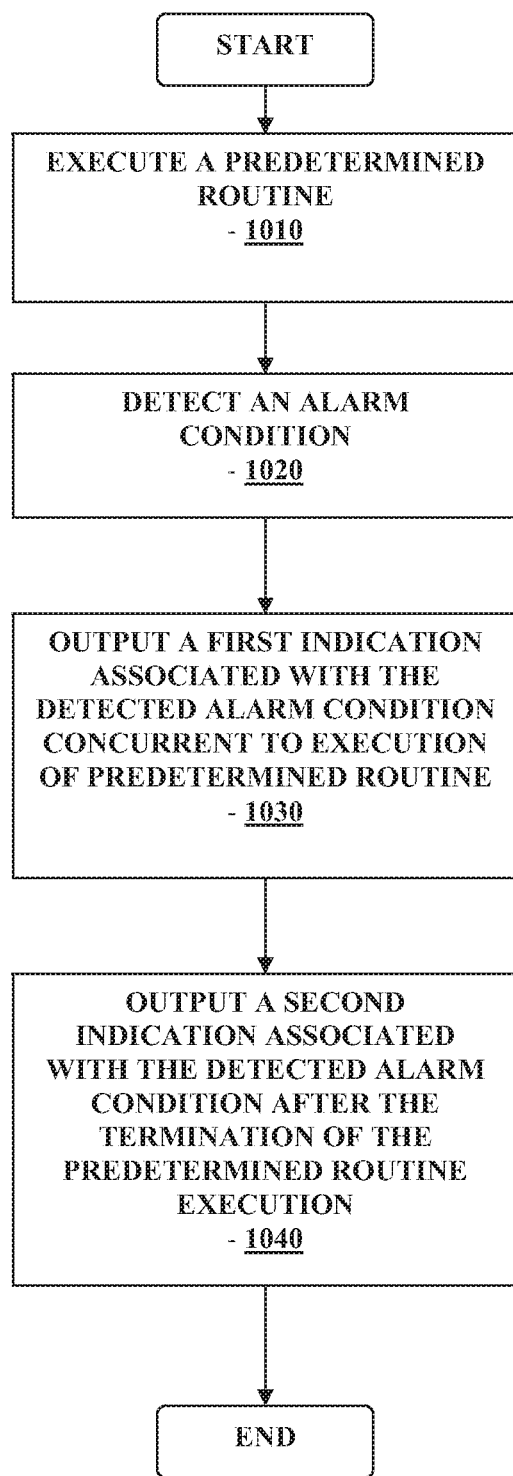

FIGURE 10

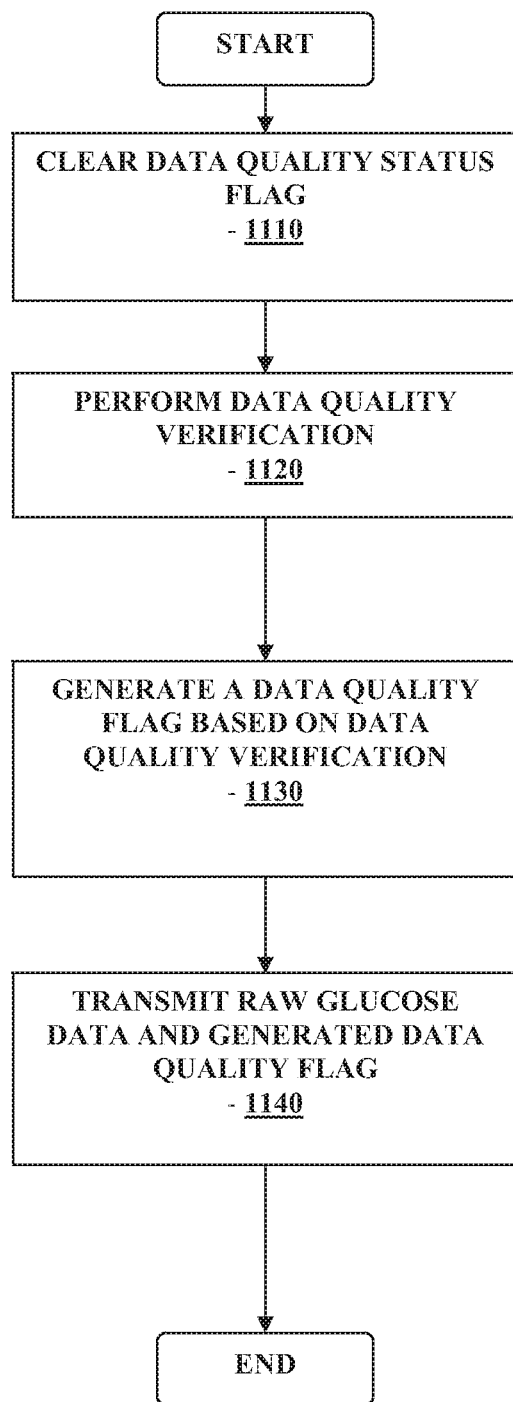

FIGURE 11

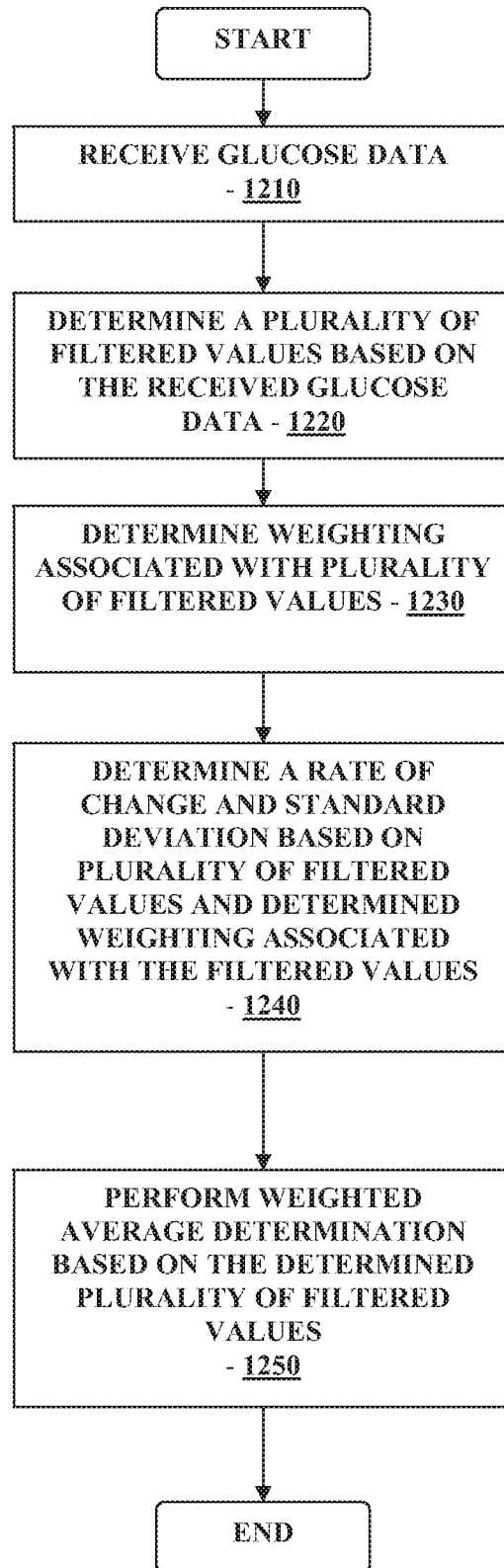

FIGURE 12

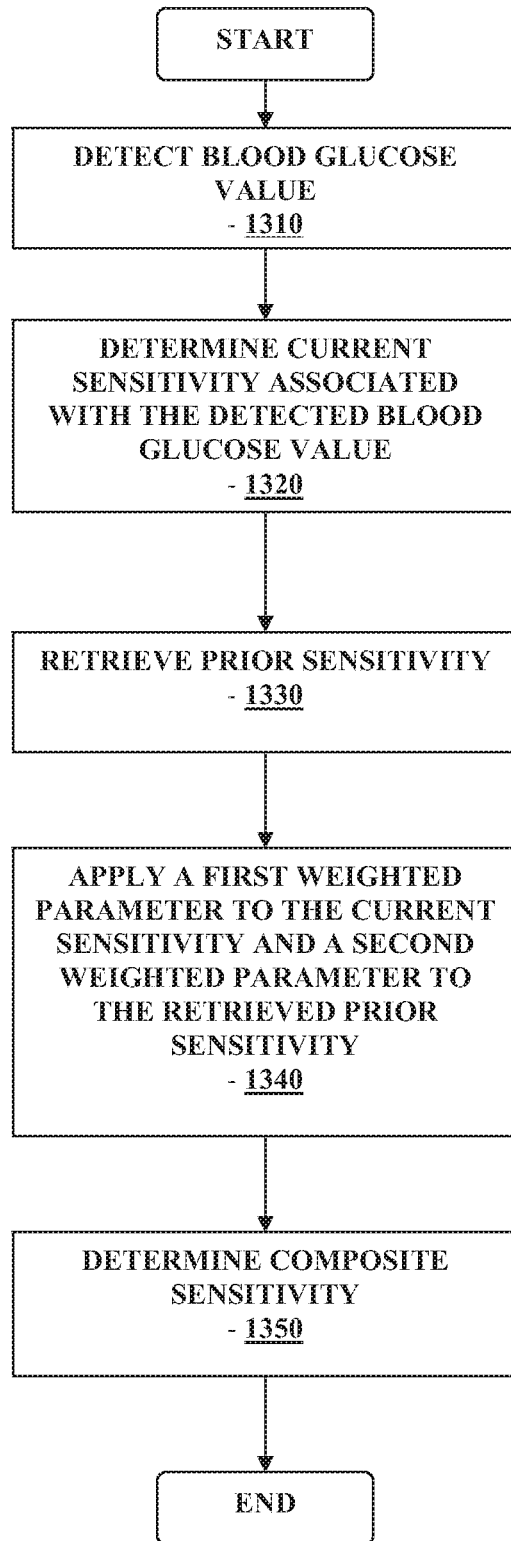

FIGURE 13

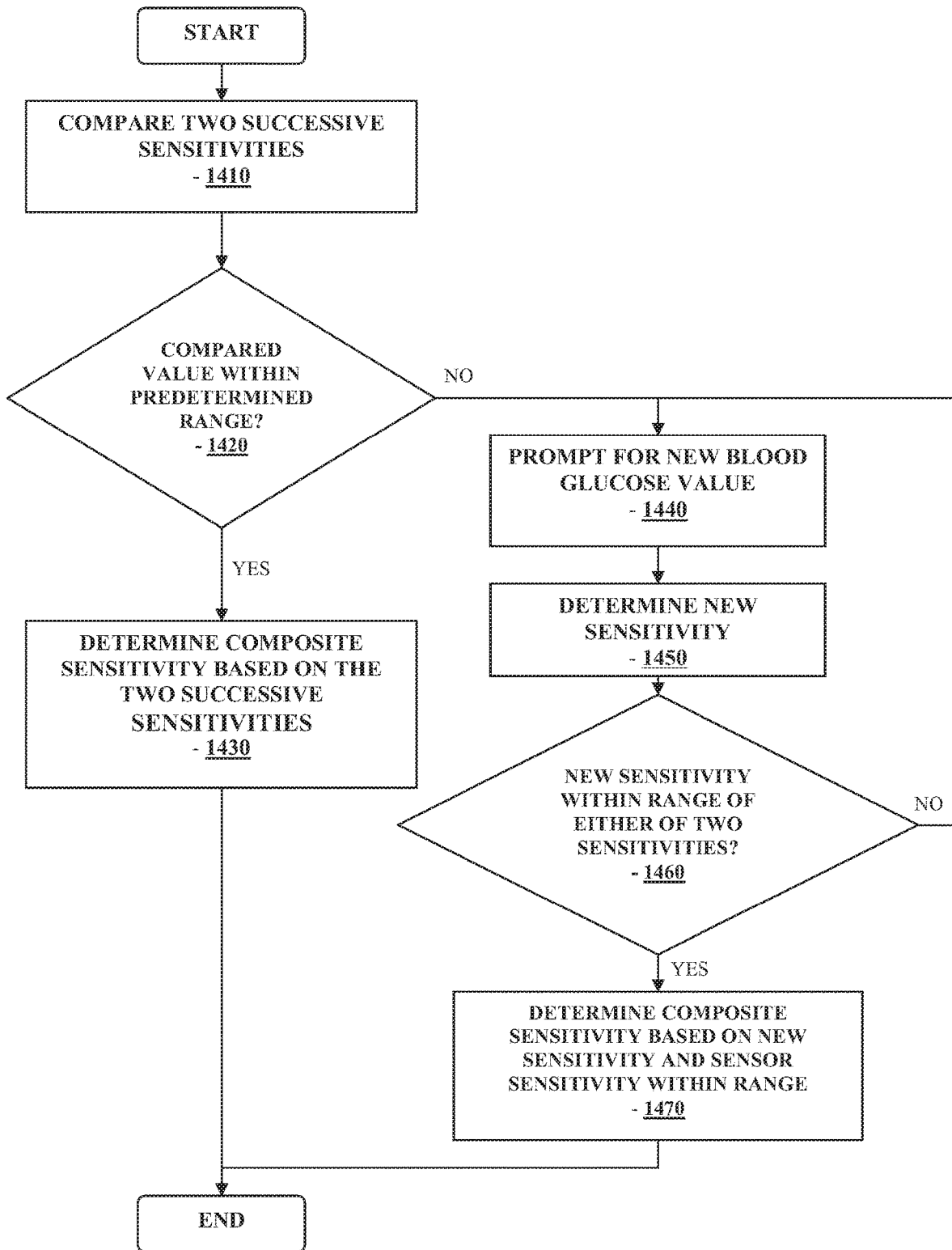

FIGURE 14

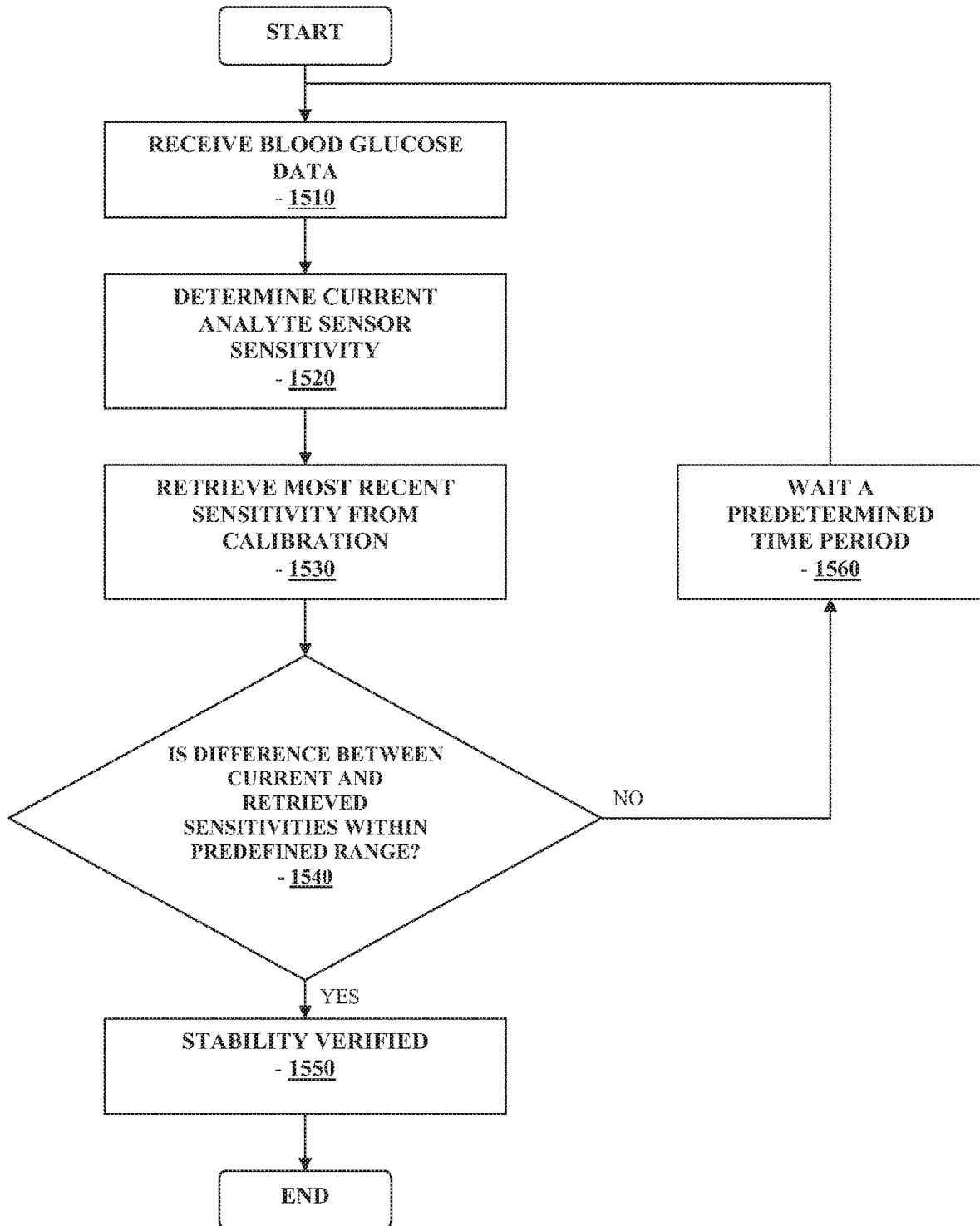

FIGURE 15

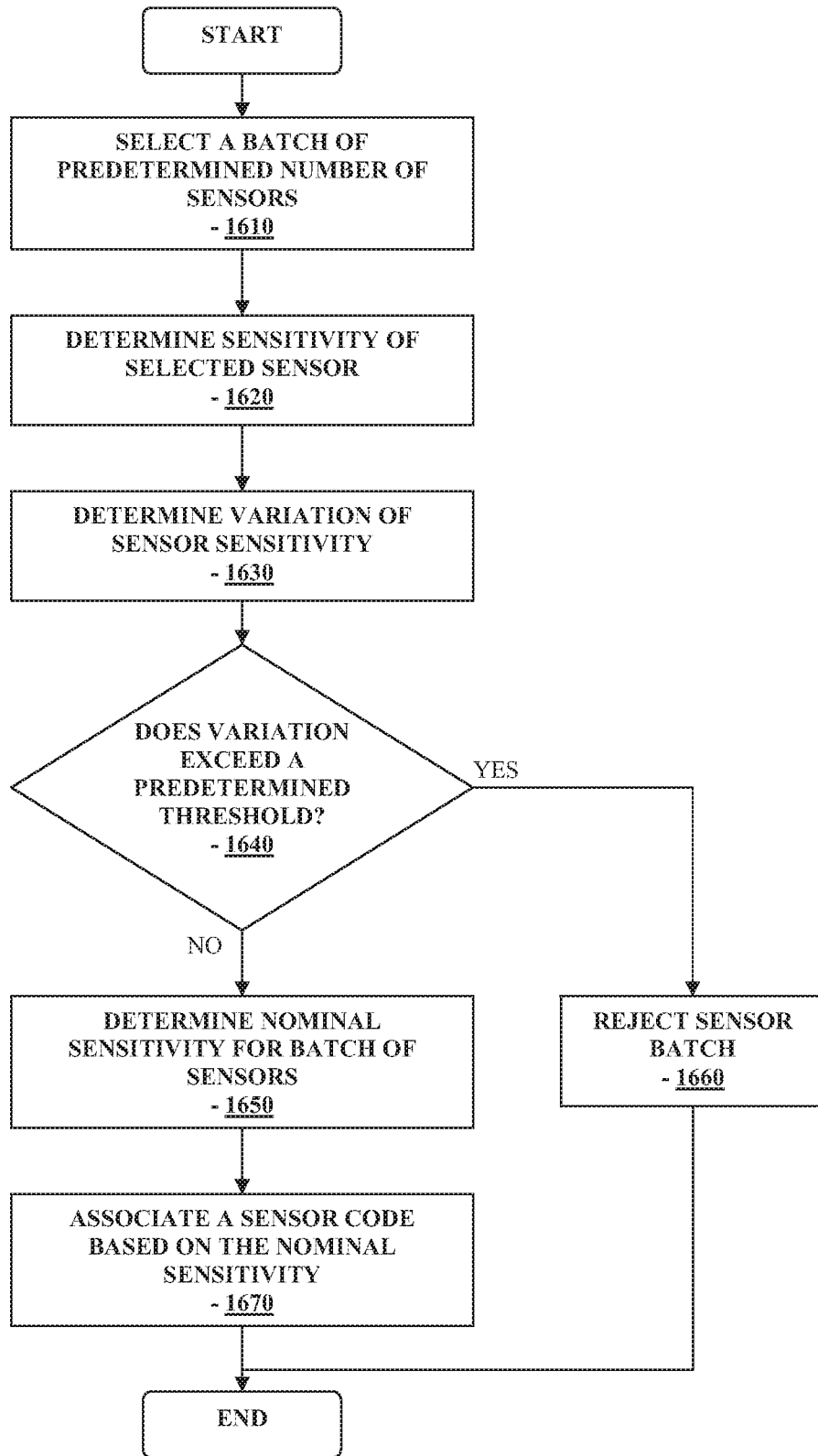

FIGURE 16

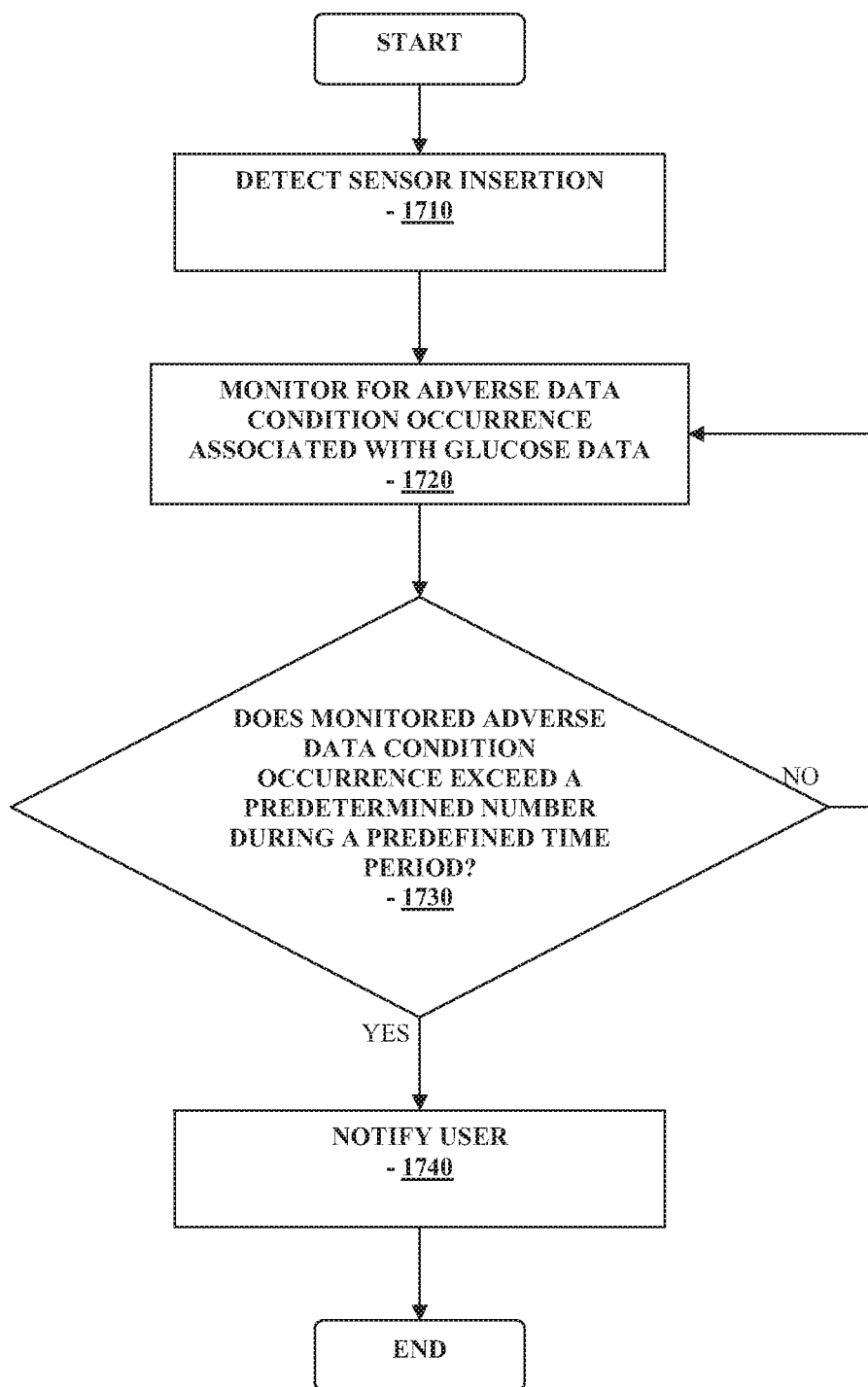

FIGURE 17

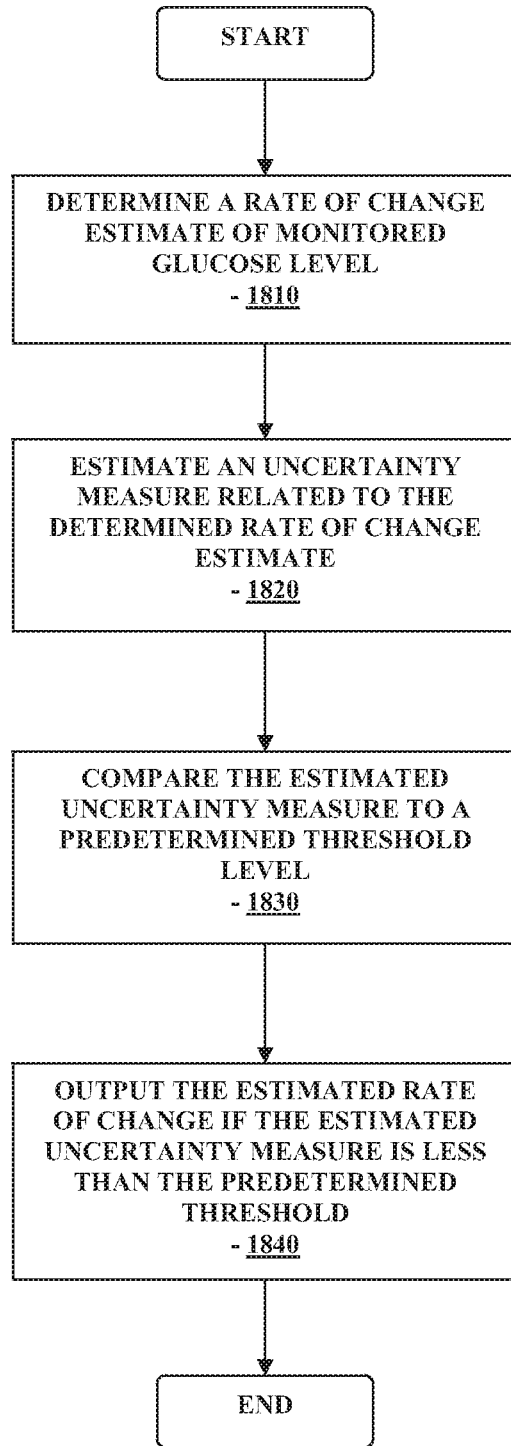

FIGURE 18

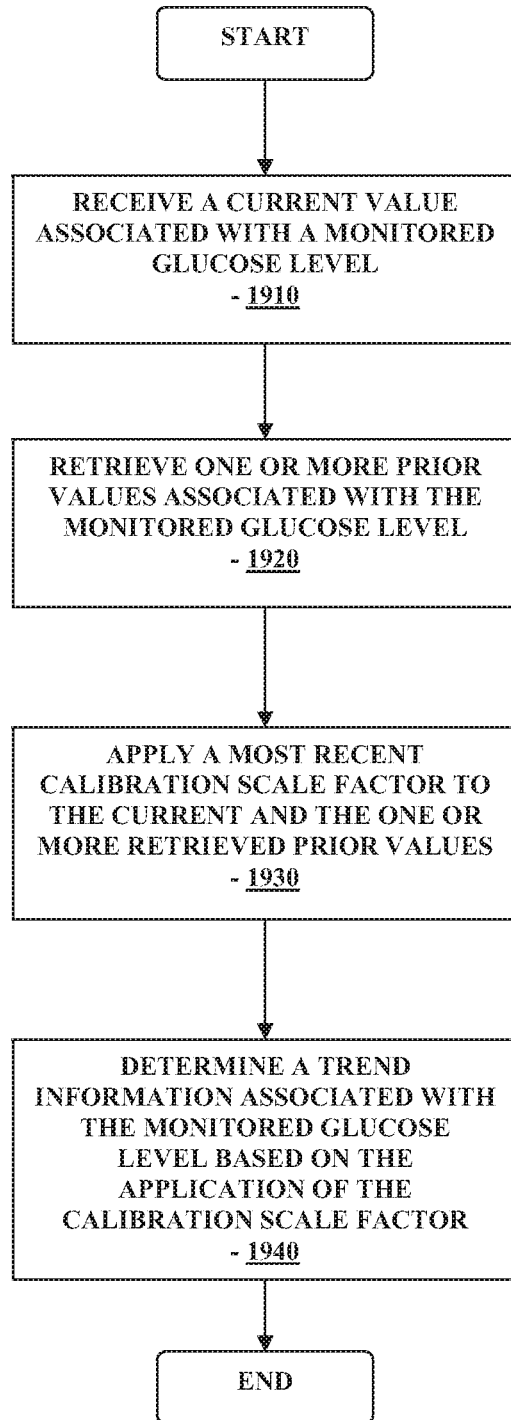

FIGURE 19

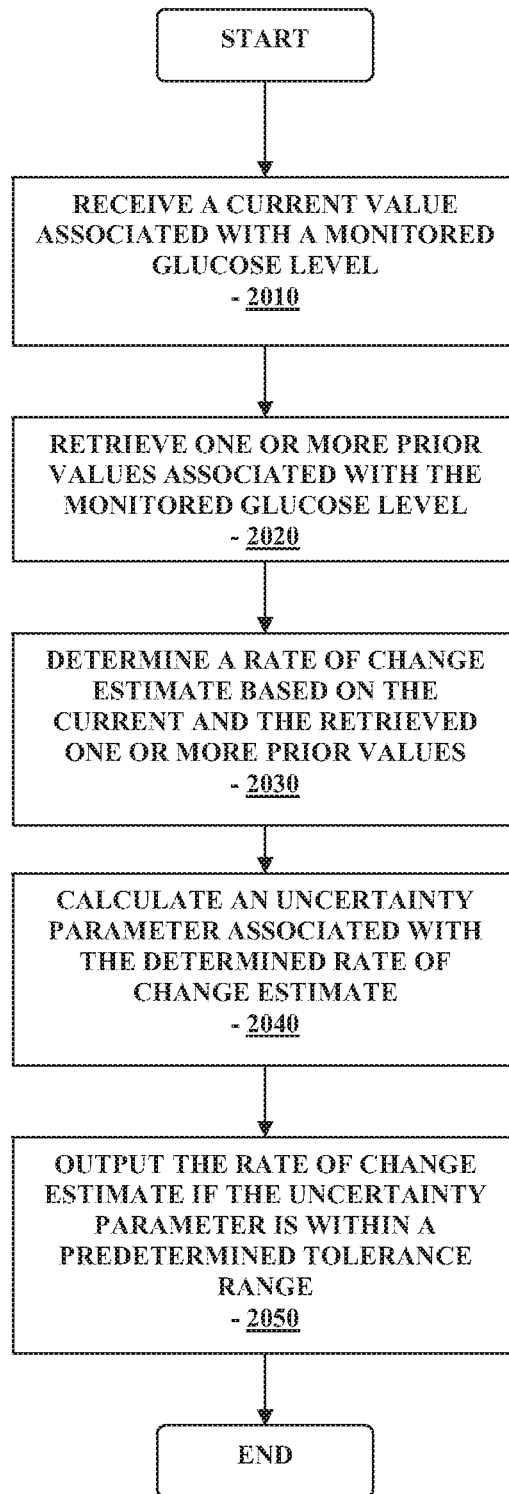

FIGURE 20

**METHOD AND APPARATUS FOR
PROVIDING DATA PROCESSING AND
CONTROL IN A MEDICAL
COMMUNICATION SYSTEM**

RELATED APPLICATIONS

[0001] The present application is a continuation of U.S. patent application Ser. No. 16/181,069 filed Nov. 5, 2018, which is a continuation of U.S. patent application Ser. No. 15/796,274 filed Oct. 27, 2017, now U.S. Pat. No. 10,119,956, is a continuation of U.S. patent application Ser. No. 14/223,893 filed Mar. 24, 2014, now U.S. Pat. No. 9,804,150, which is a continuation of U.S. patent application Ser. No. 13/567,038 filed Aug. 4, 2012, now U.S. Pat. No. 8,682,615, which is a continuation of U.S. patent application Ser. No. 12/152,652 filed May 14, 2008, now U.S. Pat. No. 8,239,166, entitled “Method And Apparatus For Providing Data Processing And Control In A Medical Communication System”, which claims priority under 35 U.S.C. § 119(e) to U.S. Provisional Application No. 60/917,837 filed May 14, 2007, entitled “Method And Apparatus For Providing Data Processing And Control In A Medical Communication System”, the disclosures of each of which are incorporated herein by reference for all purposes.

BACKGROUND

[0002] Analyte, e.g., glucose monitoring systems including continuous and discrete monitoring systems generally include a small, lightweight battery powered and microprocessor controlled system which is configured to detect signals proportional to the corresponding measured glucose levels using an electrometer, and RF signals to transmit the collected data. One aspect of certain analyte monitoring systems include a transcutaneous or subcutaneous analyte sensor configuration which is, for example, partially mounted on the skin of a subject whose analyte level is to be monitored. The sensor cell may use a two or three-electrode (work, reference and counter electrodes) configuration driven by a controlled potential (potentiostat) analog circuit connected through a contact system.

[0003] The analyte sensor may be configured so that a portion thereof is placed under the skin of the patient so as to detect the analyte levels of the patient, and another portion or segment of the analyte sensor that is in communication with the transmitter unit. The transmitter unit is configured to transmit the analyte levels detected by the sensor over a wireless communication link such as an RF (radio frequency) communication link to a receiver/monitor unit. The receiver/monitor unit performs data analysis, among others on the received analyte levels to generate information pertaining to the monitored analyte levels. To provide flexibility in analyte sensor manufacturing and/or design, among others, tolerance of a larger range of the analyte sensor sensitivities for processing by the transmitter unit is desirable.

[0004] In view of the foregoing, it would be desirable to have a method and system for providing data processing and control for use in medical telemetry systems such as, for example, analyte monitoring systems.

SUMMARY

[0005] In one embodiment, method and apparatus for sampling a predetermined number of in vivo analyte sensors, determining a sensitivity value for each of the sampled

predetermined number of analyte sensors, and determining a mean sensitivity based on the sensitivity value of the predetermined number of analyte sensors, is disclosed.

[0006] These and other objects, features and advantages of the present disclosure will become more fully apparent from the following detailed description of the embodiments, the appended claims and the accompanying drawings.

BRIEF DESCRIPTION OF THE DRAWINGS

[0007] FIG. 1 illustrates a block diagram of a data monitoring and management system for practicing one or more embodiments of the present disclosure;

[0008] FIG. 2 is a block diagram of the transmitter unit of the data monitoring and management system shown in FIG. 1 in accordance with one embodiment of the present disclosure;

[0009] FIG. 3 is a block diagram of the receiver/monitor unit of the data monitoring and management system shown in FIG. 1 in accordance with one embodiment of the present disclosure;

[0010] FIGS. 4A-4B illustrate a perspective view and a cross sectional view, respectively of an analyte sensor in accordance with one embodiment of the present disclosure;

[0011] FIG. 5 is a flowchart illustrating ambient temperature compensation routine for determining on-skin temperature information in accordance with one embodiment of the present disclosure;

[0012] FIG. 6 is a flowchart illustrating digital anti-aliasing filtering routing in accordance with one embodiment of the present disclosure;

[0013] FIG. 7 is a flowchart illustrating actual or potential sensor insertion or removal detection routine in accordance with one embodiment of the present disclosure;

[0014] FIG. 8 is a flowchart illustrating receiver unit processing corresponding to the actual or potential sensor insertion or removal detection routine of FIG. 7 in accordance with one embodiment of the present disclosure;

[0015] FIG. 9 is a flowchart illustrating data processing corresponding to the actual or potential sensor insertion or removal detection routine in accordance with another embodiment of the present disclosure;

[0016] FIG. 10 is a flowchart illustrating a concurrent passive notification routine in the data receiver/monitor unit of the data monitoring and management system of FIG. 1 in accordance with one embodiment of the present disclosure;

[0017] FIG. 11 is a flowchart illustrating a data quality verification routine in accordance with one embodiment of the present disclosure;

[0018] FIG. 12 is a flowchart illustrating a rate variance filtering routine in accordance with one embodiment of the present disclosure;

[0019] FIG. 13 is a flowchart illustrating a composite sensor sensitivity determination routine in accordance with one embodiment of the present disclosure;

[0020] FIG. 14 is a flowchart illustrating an outlier data point verification routine in accordance with one embodiment of the present disclosure;

[0021] FIG. 15 is a flowchart illustrating a sensor stability verification routine in accordance with one embodiment of the present disclosure;

[0022] FIG. 16 illustrates analyte sensor code determination in accordance with one embodiment of the present disclosure;

[0023] FIG. 17 illustrates an early user notification function associated with the analyte sensor condition in one aspect of the present disclosure;

[0024] FIG. 18 illustrates uncertainty estimation associated with glucose level rate of change determination in one aspect of the present disclosure;

[0025] FIG. 19 illustrates glucose trend determination in accordance with one embodiment of the present disclosure; and

[0026] FIG. 20 illustrates glucose trend determination in accordance with another embodiment of the present disclosure.

DETAILED DESCRIPTION

[0027] As described in further detail below, in accordance with the various embodiments of the present disclosure, there is provided a method and apparatus for providing data processing and control for use in a medical telemetry system. In particular, within the scope of the present disclosure, there are provided method and system for providing data communication and control for use in a medical telemetry system such as, for example, a continuous glucose monitoring system.

[0028] FIG. 1 illustrates a data monitoring and management system such as, for example, analyte (e.g., glucose) monitoring system 100 in accordance with one embodiment of the present disclosure. The subject invention is further described primarily with respect to a glucose monitoring system for convenience and such description is in no way intended to limit the scope of the invention. It is to be understood that the analyte monitoring system may be configured to monitor a variety of analytes, e.g., lactate, and the like.

[0029] Analytes that may be monitored include, for example, acetyl choline, amylase, bilirubin, cholesterol, chorionic gonadotropin, creatine kinase (e.g., CK-MB), creatine, DNA, fructosamine, glucose, glutamine, growth hormones, hormones, ketones, lactate, peroxide, prostate-specific antigen, prothrombin, RNA, thyroid stimulating hormone, and troponin. The concentration of drugs, such as, for example, antibiotics (e.g., gentamicin, vancomycin, and the like), digitoxin, digoxin, drugs of abuse, theophylline, and warfarin, may also be monitored.

[0030] The analyte monitoring system 100 includes a sensor 101, a transmitter unit 102 coupled to the sensor 101, and a primary receiver unit 104 which is configured to communicate with the transmitter unit 102 via a communication link 103. The primary receiver unit 104 may be further configured to transmit data to a data processing terminal 105 for evaluating the data received by the primary receiver unit 104. Moreover, the data processing terminal in one embodiment may be configured to receive data directly from the transmitter unit 102 via a communication link which may optionally be configured for bi-directional communication.

[0031] Also shown in FIG. 1 is a secondary receiver unit 106 which is operatively coupled to the communication link 103 and configured to receive data transmitted from the transmitter unit 102. Moreover, as shown in the Figure, the secondary receiver unit 106 is configured to communicate with the primary receiver unit 104 as well as the data processing terminal 105. Indeed, the secondary receiver unit 106 may be configured for bi-directional wireless communication with each of the primary receiver unit 104 and the

data processing terminal 105. As discussed in further detail below, in one embodiment of the present disclosure, the secondary receiver unit 106 may be configured to include a limited number of functions and features as compared with the primary receiver unit 104. As such, the secondary receiver unit 106 may be configured substantially in a smaller compact housing or embodied in a device such as a wrist watch, for example. Alternatively, the secondary receiver unit 106 may be configured with the same or substantially similar functionality as the primary receiver unit 104, and may be configured to be used in conjunction with a docking cradle unit for placement by bedside, for night time monitoring, and/or bi-directional communication device.

[0032] Only one sensor 101, transmitter unit 102, communication link 103, and data processing terminal 105 are shown in the embodiment of the analyte monitoring system 100 illustrated in FIG. 1. However, it will be appreciated by one of ordinary skill in the art that the analyte monitoring system 100 may include one or more sensor 101, transmitter unit 102, communication link 103, and data processing terminal 105. Moreover, within the scope of the present disclosure, the analyte monitoring system 100 may be a continuous monitoring system, or semi-continuous, or a discrete monitoring system. In a multi-component environment, each device is configured to be uniquely identified by each of the other devices in the system so that communication conflict is readily resolved between the various components within the analyte monitoring system 100.

[0033] In one embodiment of the present disclosure, the sensor 101 is physically positioned in or on the body of a user whose analyte level is being monitored. The sensor 101 may be configured to continuously sample the analyte level of the user and convert the sampled analyte level into a corresponding data signal for transmission by the transmitter unit 102. In one embodiment, the transmitter unit 102 is coupled to the sensor 101 so that both devices are positioned on the user's body, with at least a portion of the analyte sensor 101 positioned transcutaneously under the skin layer of the user. The transmitter unit 102 performs data processing such as filtering and encoding on data signals, each of which corresponds to a sampled analyte level of the user, for transmission to the primary receiver unit 104 via the communication link 103.

[0034] In one embodiment, the analyte monitoring system 100 is configured as a one-way RF communication path from the transmitter unit 102 to the primary receiver unit 104. In such embodiment, the transmitter unit 102 transmits the sampled data signals received from the sensor 101 without acknowledgement from the primary receiver unit 104 that the transmitted sampled data signals have been received. For example, the transmitter unit 102 may be configured to transmit the encoded sampled data signals at a fixed rate (e.g., at one minute intervals) after the completion of the initial power on procedure. Likewise, the primary receiver unit 104 may be configured to detect such transmitted encoded sampled data signals at predetermined time intervals. Alternatively, the analyte monitoring system 100 may be configured with a bi-directional RF (or otherwise) communication between the transmitter unit 102 and the primary receiver unit 104.

[0035] Additionally, in one aspect, the primary receiver unit 104 may include two sections. The first section is an analog interface section that is configured to communicate

with the transmitter unit **102** via the communication link **103**. In one embodiment, the analog interface section may include an RF receiver and an antenna for receiving and amplifying the data signals from the transmitter unit **102**, which are thereafter, demodulated with a local oscillator and filtered through a band-pass filter. The second section of the primary receiver unit **104** is a data processing section which is configured to process the data signals received from the transmitter unit **102** such as by performing data decoding, error detection and correction, data clock generation, and data bit recovery.

[0036] In operation, upon completing the power-on procedure, the primary receiver unit **104** is configured to detect the presence of the transmitter unit **102** within its range based on, for example, the strength of the detected data signals received from the transmitter unit **102** or a predetermined transmitter identification information. Upon successful synchronization with the corresponding transmitter unit **102**, the primary receiver unit **104** is configured to begin receiving from the transmitter unit **102** data signals corresponding to the user's detected analyte level. More specifically, the primary receiver unit **104** in one embodiment is configured to perform synchronized time hopping with the corresponding synchronized transmitter unit **102** via the communication link **103** to obtain the user's detected analyte level.

[0037] Referring again to FIG. 1, the data processing terminal **105** may include a personal computer, a portable computer such as a laptop or a handheld device (e.g., personal digital assistants (PDAs)), and the like, each of which may be configured for data communication with the receiver via a wired or a wireless connection. Additionally, the data processing terminal **105** may further be connected to a data network (not shown) for storing, retrieving and updating data corresponding to the detected analyte level of the user.

[0038] Within the scope of the present disclosure, the data processing terminal **105** may include an infusion device such as an insulin infusion pump or the like, which may be configured to administer insulin to patients, and which may be configured to communicate with the receiver unit **104** for receiving, among others, the measured analyte level. Alternatively, the receiver unit **104** may be configured to integrate an infusion device therein so that the receiver unit **104** is configured to administer insulin therapy to patients, for example, for administering and modifying basal profiles, as well as for determining appropriate boluses for administration based on, among others, the detected analyte levels received from the transmitter unit **102**.

[0039] Additionally, the transmitter unit **102**, the primary receiver unit **104** and the data processing terminal **105** may each be configured for bi-directional wireless communication such that each of the transmitter unit **102**, the primary receiver unit **104** and the data processing terminal **105** may be configured to communicate (that is, transmit data to and receive data from) with each other via a wireless communication link. More specifically, the data processing terminal **105** may in one embodiment be configured to receive data directly from the transmitter unit **102** via a communication link, where the communication link, as described above, may be configured for bi-directional communication.

[0040] In this embodiment, the data processing terminal **105** which may include an insulin pump, may be configured to receive the analyte signals from the transmitter unit **102**,

and thus, incorporate the functions of the receiver unit **104** including data processing for managing the patient's insulin therapy and analyte monitoring. In one embodiment, the communication link **103** may include one or more of an RF communication protocol, an infrared communication protocol, a Bluetooth® enabled communication protocol, an 802.11x wireless communication protocol, a Zigbee® transmission protocol, or an equivalent wireless communication protocol which would allow secure, wireless communication of several units (for example, per HIPAA requirements) while avoiding potential data collision and interference.

[0041] FIG. 2 is a block diagram of the transmitter of the data monitoring and detection system shown in FIG. 1 in accordance with one embodiment of the present disclosure. Referring to the Figure, the transmitter unit **102** in one embodiment includes an analog interface **201** configured to communicate with the sensor **101** (FIG. 1), a user input **202**, and a temperature detection section **203**, each of which is operatively coupled to a transmitter processor **204** such as a central processing unit (CPU).

[0042] Further shown in FIG. 2 are a transmitter serial communication section **205** and an RF transmitter **206**, each of which is also operatively coupled to the transmitter processor **204**. Moreover, a power supply **207** such as a battery is also provided in the transmitter unit **102** to provide the necessary power for the transmitter unit **102**. Additionally, as can be seen from the Figure, clock **208** is provided to, among others, supply real time information to the transmitter processor **204**.

[0043] As can be seen from FIG. 2, the sensor **101** (FIG. 1) is provided four contacts, three of which are electrodes—work electrode (W) **210**, guard contact (G) **211**, reference electrode (R) **212**, and counter electrode (C) **213**, each operatively coupled to the analog interface **201** of the transmitter unit **102**. In one embodiment, each of the work electrode (W) **210**, guard contact (G) **211**, reference electrode (R) **212**, and counter electrode (C) **213** may be made using a conductive material that is either printed or etched, for example, such as carbon which may be printed, or metal foil (e.g., gold) which may be etched, or alternatively provided on a substrate material using laser or photolithography.

[0044] In one embodiment, a unidirectional input path is established from the sensor **101** (FIG. 1) and/or manufacturing and testing equipment to the analog interface **201** of the transmitter unit **102**, while a unidirectional output is established from the output of the RF transmitter **206** of the transmitter unit **102** for transmission to the primary receiver unit **104**. In this manner, a data path is shown in FIG. 2 between the aforementioned unidirectional input and output via a dedicated link **209** from the analog interface **201** to serial communication section **205**, thereafter to the processor **204**, and then to the RF transmitter **206**. As such, in one embodiment, via the data path described above, the transmitter unit **102** is configured to transmit to the primary receiver unit **104** (FIG. 1), via the communication link **103** (FIG. 1), processed and encoded data signals received from the sensor **101** (FIG. 1). Additionally, the unidirectional communication data path between the analog interface **201** and the RF transmitter **206** discussed above allows for the configuration of the transmitter unit **102** for operation upon completion of the manufacturing process as well as for direct communication for diagnostic and testing purposes.

[0045] As discussed above, the transmitter processor 204 is configured to transmit control signals to the various sections of the transmitter unit 102 during the operation of the transmitter unit 102. In one embodiment, the transmitter processor 204 also includes a memory (not shown) for storing data such as the identification information for the transmitter unit 102, as well as the data signals received from the sensor 101. The stored information may be retrieved and processed for transmission to the primary receiver unit 104 under the control of the transmitter processor 204. Furthermore, the power supply 207 may include a commercially available battery.

[0046] The transmitter unit 102 is also configured such that the power supply section 207 is capable of providing power to the transmitter for a minimum of about three months of continuous operation after having been stored for about eighteen months in a low-power (non-operating) mode. In one embodiment, this may be achieved by the transmitter processor 204 operating in low power modes in the non-operating state, for example, drawing no more than approximately 1 μ A of current. Indeed, in one embodiment, the final step during the manufacturing process of the transmitter unit 102 may place the transmitter unit 102 in the lower power, non-operating state (i.e., post-manufacture sleep mode). In this manner, the shelf life of the transmitter unit 102 may be significantly improved. Moreover, as shown in FIG. 2, while the power supply unit 207 is shown as coupled to the processor 204, and as such, the processor 204 is configured to provide control of the power supply unit 207, it should be noted that within the scope of the present disclosure, the power supply unit 207 is configured to provide the necessary power to each of the components of the transmitter unit 102 shown in FIG. 2.

[0047] Referring back to FIG. 2, the power supply section 207 of the transmitter unit 102 in one embodiment may include a rechargeable battery unit that may be recharged by a separate power supply recharging unit (for example, provided in the receiver unit 104) so that the transmitter unit 102 may be powered for a longer period of usage time. Moreover, in one embodiment, the transmitter unit 102 may be configured without a battery in the power supply section 207, in which case the transmitter unit 102 may be configured to receive power from an external power supply source (for example, a battery) as discussed in further detail below.

[0048] Referring yet again to FIG. 2, the temperature detection section 203 of the transmitter unit 102 is configured to monitor the temperature of the skin near the sensor insertion site. The temperature reading is used to adjust the analyte readings obtained from the analog interface 201. The RF transmitter 206 of the transmitter unit 102 may be configured for operation in the frequency band of 315 MHz to 322 MHz, for example, in the United States. Further, in one embodiment, the RF transmitter 206 is configured to modulate the carrier frequency by performing Frequency Shift Keying and Manchester encoding. In one embodiment, the data transmission rate is 19,200 symbols per second, with a minimum transmission range for communication with the primary receiver unit 104.

[0049] Referring yet again to FIG. 2, also shown is a leak detection circuit 214 coupled to the guard contact (G) 211 and the processor 204 in the transmitter unit 102 of the data monitoring and management system 100. The leak detection circuit 214 in accordance with one embodiment of the present disclosure may be configured to detect leakage

current in the sensor 101 to determine whether the measured sensor data is corrupt or whether the measured data from the sensor 101 is accurate.

[0050] FIG. 3 is a block diagram of the receiver/monitor unit of the data monitoring and management system shown in FIG. 1 in accordance with one embodiment of the present disclosure. Referring to FIG. 3, the primary receiver unit 104 includes a blood glucose test strip interface 301, an RF receiver 302, a user input 303, a temperature detection section 304, and a clock 305, each of which is operatively coupled to a receiver processor 307. As can be further seen from the Figure, the primary receiver unit 104 also includes a power supply 306 operatively coupled to a power conversion and monitoring section 308. Further, the power conversion and monitoring section 308 is also coupled to the receiver processor 307. Moreover, also shown are a receiver serial communication section 309, and an output 310, each operatively coupled to the receiver processor 307.

[0051] In one embodiment, the test strip interface 301 includes a glucose level testing portion to receive a manual insertion of a glucose test strip, and thereby determine and display the glucose level of the test strip on the output 310 of the primary receiver unit 104. This manual testing of glucose can be used to calibrate sensor 101. The RF receiver 302 is configured to communicate, via the communication link 103 (FIG. 1) with the RF transmitter 206 of the transmitter unit 102, to receive encoded data signals from the transmitter unit 102 for, among others, signal mixing, demodulation, and other data processing. The input 303 of the primary receiver unit 104 is configured to allow the user to enter information into the primary receiver unit 104 as needed. In one aspect, the input 303 may include one or more keys of a keypad, a touch-sensitive screen, or a voice-activated input command unit. The temperature detection section 304 is configured to provide temperature information of the primary receiver unit 104 to the receiver processor 307, while the clock 305 provides, among others, real time information to the receiver processor 307.

[0052] Each of the various components of the primary receiver unit 104 shown in FIG. 3 is powered by the power supply 306 which, in one embodiment, includes a battery. Furthermore, the power conversion and monitoring section 308 is configured to monitor the power usage by the various components in the primary receiver unit 104 for effective power management and to alert the user, for example, in the event of power usage which renders the primary receiver unit 104 in sub-optimal operating conditions. An example of such sub-optimal operating condition may include, for example, operating the vibration output mode (as discussed below) for a period of time thus substantially draining the power supply 306 while the processor 307 (thus, the primary receiver unit 104) is turned on. Moreover, the power conversion and monitoring section 308 may additionally be configured to include a reverse polarity protection circuit such as a field effect transistor (FET) configured as a battery activated switch.

[0053] The serial communication section 309 in the primary receiver unit 104 is configured to provide a bi-directional communication path from the testing and/or manufacturing equipment for, among others, initialization, testing, and configuration of the primary receiver unit 104. Serial communication section 309 can also be used to upload data to a computer, such as time-stamped blood glucose data. The communication link with an external device (not

shown) can be made, for example, by cable, infrared (IR) or RF link. The output 310 of the primary receiver unit 104 is configured to provide, among others, a graphical user interface (GUI) such as a liquid crystal display (LCD) for displaying information. Additionally, the output 310 may also include an integrated speaker for outputting audible signals as well as to provide vibration output as commonly found in handheld electronic devices, such as mobile telephones presently available. In a further embodiment, the primary receiver unit 104 also includes an electro-luminescent lamp configured to provide backlighting to the output 310 for output visual display in dark ambient surroundings.

[0054] Referring back to FIG. 3, the primary receiver unit 104 in one embodiment may also include a storage section such as a programmable, non-volatile memory device as part of the processor 307, or provided separately in the primary receiver unit 104, operatively coupled to the processor 307. The processor 307 is further configured to perform Manchester decoding as well as error detection and correction upon the encoded data signals received from the transmitter unit 102 via the communication link 103.

[0055] In a further embodiment, the one or more of the transmitter unit 102, the primary receiver unit 104, secondary receiver unit 106, or the data processing terminal/infusion section 105 may be configured to receive the blood glucose value wirelessly over a communication link from, for example, a glucose meter. In still a further embodiment, the user or patient manipulating or using the analyte monitoring system 100 (FIG. 1) may manually input the blood glucose value using, for example, a user interface (for example, a keyboard, keypad, and the like) incorporated in the one or more of the transmitter unit 102, the primary receiver unit 104, secondary receiver unit 106, or the data processing terminal/infusion section 105.

[0056] Additional detailed description of the continuous analyte monitoring system, and its various components including the functional descriptions of the transmitter are provided in U.S. Pat. No. 6,175,752 issued Jan. 16, 2001 entitled "Analyte Monitoring Device and Methods of Use", and in application Ser. No. 10/745,878 filed Dec. 26, 2003, now U.S. Pat. No. 7,811,231, entitled "Continuous Glucose Monitoring System and Methods of Use", each assigned to the Assignee of the present application, and each of which are incorporated herein by reference for all purposes.

[0057] FIGS. 4A-4B illustrate a perspective view and a cross sectional view, respectively of an analyte sensor in accordance with one embodiment of the present disclosure. Referring to FIG. 4A, a perspective view of a sensor 400, the major portion of which is above the surface of the skin 410, with an insertion tip 430 penetrating through the skin and into the subcutaneous space 420 in contact with the user's biofluid such as interstitial fluid. Contact portions of a working electrode 401, a reference electrode 402, and a counter electrode 403 can be seen on the portion of the sensor 400 situated above the skin surface 410. Working electrode 401, a reference electrode 402, and a counter electrode 403 can be seen at the end of the insertion tip 430.

[0058] Referring now to FIG. 4B, a cross sectional view of the sensor 400 in one embodiment is shown. In particular, it can be seen that the various electrodes of the sensor 400 as well as the substrate and the dielectric layers are provided in a stacked or layered configuration or construction. For example, as shown in FIG. 4B, in one aspect, the sensor 400 (such as the sensor 101 FIG. 1), includes a substrate layer

404, and a first conducting layer 401 such as a carbon trace disposed on at least a portion of the substrate layer 404, and which may comprise the working electrode. Also shown disposed on at least a portion of the first conducting layer 401 is a sensing layer 408.

[0059] Referring back to FIG. 4B, a first insulation layer such as a first dielectric layer 405 is disposed or stacked on at least a portion of the first conducting layer 401, and further, a second conducting layer 409 such as another carbon trace may be disposed or stacked on top of at least a portion of the first insulation layer (or dielectric layer) 405. As shown in FIG. 4B, the second conducting layer 409 may comprise the reference electrode 402, and in one aspect, may include a layer of silver/silver chloride (Ag/AgCl).

[0060] Referring still again to FIG. 4B, a second insulation layer 406 such as a dielectric layer in one embodiment may be disposed or stacked on at least a portion of the second conducting layer 409. Further, a third conducting layer 403 which may include carbon trace and that may comprise the counter electrode 403 may in one embodiment be disposed on at least a portion of the second insulation layer 406. Finally, a third insulation layer 407 is disposed or stacked on at least a portion of the third conducting layer 403. In this manner, the sensor 400 may be configured in a stacked or layered construction or configuration such that at least a portion of each of the conducting layers is separated by a respective insulation layer (for example, a dielectric layer).

[0061] Additionally, within the scope of the present disclosure, some or all of the electrodes 401, 402, 403 may be provided on the same side of the substrate 404 in a stacked construction as described above, or alternatively, may be provided in a co-planar manner such that each electrode is disposed on the same plane on the substrate 404, however, with a dielectric material or insulation material disposed between the conducting layers/electrodes. Furthermore, in still another aspect of the present disclosure, the one or more conducting layers such as the electrodes 401, 402, 403 may be disposed on opposing sides of the substrate 404.

[0062] Referring back to the Figures, in one embodiment, the transmitter unit 102 (FIG. 1) is configured to detect the current signal from the sensor 101 (FIG. 1) and the skin temperature near the sensor 101, which are preprocessed by, for example, the transmitter processor 204 (FIG. 2) and transmitted to the receiver unit (for example, the primary receiver unit 104 (FIG. 1)) periodically at a predetermined time interval, such as for example, but not limited to, once per minute, once every two minutes, once every five minutes, or once every ten minutes. Additionally, the transmitter unit 102 may be configured to perform sensor insertion detection and data quality analysis, information pertaining to which are also transmitted to the receiver unit 104 periodically at the predetermined time interval. In turn, the receiver unit 104 may be configured to perform, for example, skin temperature compensation as well as calibration of the sensor data received from the transmitter unit 102.

[0063] For example, in one aspect, the transmitter unit 102 may be configured to oversample the sensor signal at a nominal rate of four samples per second, which allows the analyte anti-aliasing filter in the transmitter unit 102 to attenuate noise (for example, due to effects resulting from motion or movement of the sensor after placement) at frequencies above 2 Hz. More specifically, in one embodiment, the transmitter processor 204 may be configured to include a digital filter to reduce aliasing noise when deci-

ating the four Hz sampled sensor data to once per minute samples for transmission to the receiver unit 104. As discussed in further detail below, in one aspect, a two stage Kaiser FIR filter may be used to perform the digital filtering for anti-aliasing. While Kaiser FIR filter may be used for digital filtering of the sensor signals, within the scope of the present disclosure, other suitable filters may be used to filter the sensor signals.

[0064] In one aspect, the temperature measurement section 203 of the transmitter unit 102 may be configured to measure once per minute the on skin temperature near the analyte sensor at the end of the minute sampling cycle of the sensor signal. Within the scope of the present disclosure, different sample rates may be used which may include, for example, but not limited to, measuring the on skin temperature for each 30 second periods, each two minute periods, and the like. Additionally, as discussed above, the transmitter unit 102 may be configured to detect sensor insertion, sensor signal settling after sensor insertion, and sensor removal, in addition to detecting for sensor—transmitter system failure modes and sensor signal data integrity. Again, this information is transmitted periodically by the transmitter unit 102 to the receiver unit 104 along with the sampled sensor signals at the predetermined time intervals.

[0065] Referring again to the Figures, as the analyte sensor measurements are affected by the temperature of the tissue around the transcutaneously positioned sensor 101, in one aspect, compensation of the temperature variations and effects on the sensor signals are provided for determining the corresponding glucose value. Moreover, the ambient temperature around the sensor 101 may affect the accuracy of the on skin temperature measurement and ultimately the glucose value determined from the sensor signals. Accordingly, in one aspect, a second temperature sensor is provided in the transmitter unit 102 away from the on skin temperature sensor (for example, physically away from the temperature measurement section 203 of the transmitter unit 102), so as to provide compensation or correction of the on skin temperature measurements due to the ambient temperature effects. In this manner, the accuracy of the estimated glucose value corresponding to the sensor signals may be attained.

[0066] In one aspect, the processor 204 of the transmitter unit 102 may be configured to include the second temperature sensor, and which is located closer to the ambient thermal source within the transmitter unit 102. In other embodiments, the second temperature sensor may be located at a different location within the transmitter unit 102 housing where the ambient temperature within the housing of the transmitter unit 102 may be accurately determined.

[0067] Referring now to FIG. 5, in one aspect, an ambient temperature compensation routine for determining the on-skin temperature level for use in the glucose estimation determination based on the signals received from the sensor 101. Referring to FIG. 5, for each sampled signal from the sensor 101, a corresponding measured temperature information is received (510), for example, by the processor 204 from the temperature measurement section 203 (which may include, for example, a thermistor provided in the transmitter unit 102). In addition, a second temperature measurement is obtained (520), for example, including a determination of the ambient temperature level using a second temperature sensor provided within the housing the transmitter unit 102.

[0068] In one aspect, based on a predetermined ratio of thermal resistances between the temperature measurement

section 203 and the second temperature sensor (located, for example, within the processor 204 of the transmitter unit 102), and between the temperature measurement section 203 and the skin layer on which the transmitter unit 102 is placed and coupled to the sensor 101, ambient temperature compensation may be performed (530), to determine the corresponding ambient temperature compensated on skin temperature level (540). In one embodiment, the predetermined ratio of the thermal resistances may be approximately 0.2. However, within the scope of the present disclosure, this thermal resistance ratio may vary according to the design of the system, for example, based on the size of the transmitter unit 102 housing, the location of the second temperature sensor within the housing of the transmitter unit 102, and the like.

[0069] With the ambient temperature compensated on-skin temperature information, the corresponding glucose value from the sampled analyte sensor signal may be determined.

[0070] Referring again to FIG. 2, the processor 204 of the transmitter unit 102 may include a digital anti-aliasing filter. Using analog anti-aliasing filters for a one minute measurement data sample rate would require a large capacitor in the transmitter unit 102 design, and which in turn impacts the size of the transmitter unit 102. As such, in one aspect, the sensor signals may be oversampled (for example, at a rate of 4 times per second), and then the data is digitally decimated to derive a one-minute sample rate.

[0071] As discussed above, in one aspect, the digital anti-aliasing filter may be used to remove, for example, signal artifacts or otherwise undesirable aliasing effects on the sampled digital signals received from the analog interface 201 of the transmitter unit 102. For example, in one aspect, the digital anti-aliasing filter may be used to accommodate decimation of the sensor data from approximately four Hz samples to one-minute samples. In one aspect, a two stage FIR filter may be used for the digital anti-aliasing filter, which includes improved response time, pass band and stop band properties.

[0072] Referring to FIG. 6, a routine for digital anti-aliasing filtering is shown in accordance with one embodiment. As shown, in one embodiment, at each predetermined time period such as every minute, the analog signal from the analog interface 201 corresponding to the monitored analyte level received from the sensor 101 (FIG. 1) is sampled (610). For example, at every minute, in one embodiment, the signal from the analog interface 201 is over-sampled at approximately 4 Hz. Thereafter, the first stage digital filtering on the over-sampled data is performed (620), where, for example, a $\frac{1}{2}$ down-sampling from 246 samples to 41 samples is performed, and the resulting 41 samples is further down-sampled at the second stage digital filtering (630) such that, for example, a $\frac{1}{41}$ down-sampling is performed from 41 samples (from the first stage digital filtering), to a single sample. Thereafter, the filter is reset (640), and the routine returns to the beginning for the next minute signal received from the analog interface 201.

[0073] While the use of FIR filter, and in particular the use of Kaiser FIR filter, is within the scope of the present disclosure, other suitable filters, such as FIR filters with different weighting schemes or IIR filters, may be used.

[0074] Referring yet again to the Figures, the transmitter unit 102 may be configured in one embodiment to periodically perform data quality checks including error condition

verifications and potential error condition detections, and also to transmit the relevant information related to one or more data quality, error condition or potential error condition detection to the receiver unit 104 with the transmission of the monitored sensor data. For example, in one aspect, a state machine may be used in conjunction with the transmitter unit 102 and which may be configured to be updated four times per second, the results of which are transmitted to the receiver unit 104 every minute.

[0075] In particular, using the state machine, the transmitter unit 102 may be configured to detect one or more states that may indicate when a sensor is inserted, when a sensor is removed from the user, and further, may additionally be configured to perform related data quality checks so as to determine when a new sensor has been inserted or transcutaneously positioned under the skin layer of the user and has settled in the inserted state such that the data transmitted from the transmitter unit 102 does not compromise the integrity of signal processing performed by the receiver unit 104 due to, for example, signal transients resulting from the sensor insertion.

[0076] That is, when the transmitter unit 102 detects low or no signal from the sensor 101, which is followed by detected signals from the sensor 101 that is above a given signal, the processor 204 may be configured to identify such transition is monitored signal levels and associate with a potential sensor insertion state. Alternatively, the transmitter unit 102 may be configured to detect the signal level above another predetermined threshold level, which is followed by the detection of the signal level from the sensor 101 that falls below the predetermined threshold level. In such a case, the processor 204 may be configured to associate or identify such transition or condition in the monitored signal levels as a potential sensor removal state.

[0077] Accordingly, when either of potential sensor insertion state or potential sensor removal state is detected by the transmitter unit 102, this information is transmitted to the receiver unit 104, and in turn, the receiver unit may be configured to prompt the user for confirmation of either of the detected potential sensor related state. In another aspect, the sensor insertion state or potential sensor removal state may be detected or determined by the receiver unit based on one or more signals received from the transmitter unit 102. For example, similar to an alarm condition or a notification to the user, the receiver unit 104 may be configured to display a request or a prompt on the display or an output unit of the receiver unit 104 a text and/or other suitable notification message to inform the user to confirm the state of the sensor 101.

[0078] For example, the receiver unit 104 may be configured to display the following message: "New Sensor Inserted?" or a similar notification in the case where the receiver unit 104 receives one or more signals from the transmitter unit 102 associated with the detection of the signal level below the predetermined threshold level for the predefined period of time, followed by the detection of the signal level from the sensor 101 above another predetermined threshold level for another predefined period of time. Additionally, the receiver unit 104 may be configured to display the following message: "Sensor Removed?" or a similar notification in the case where the receiver unit 104 received one or more signals from the transmitter unit 102 associated with the detection of the signal level from the sensor 101 that is above another predetermined threshold

level for another predefined period of time, which is followed by the detection of the signal level from the sensor 101 that falls below the predetermined threshold level for the predefined period of time.

[0079] Based on the user confirmation received, the receiver unit 104 may be further configured to execute or perform additional related processing and routines in response to the user confirmation or acknowledgement. For example, when the user confirms, using the user interface input/output mechanism of the receiver unit 104, for example, that a new sensor has been inserted, the receiver unit 104 may be configured to initiate new sensor insertion related routines including, such as, for example, a sensor calibration routine including, for example, calibration timer, sensor expiration timer and the like. Alternatively, when the user confirms or it is determined that the sensor 101 is not properly positioned or otherwise removed from the insertion site, the receiver unit 104 may be accordingly configured to perform related functions such as, for example, stop displaying of the glucose values/levels, or deactivating the alarm monitoring conditions.

[0080] On the other hand, in response to the potential sensor insertion notification generated by the receiver unit 104, if the user confirms that no new sensor has been inserted, then the receiver unit 104 in one embodiment is configured to assume that the sensor 101 is in acceptable operational state, and continues to receive and process signals from the transmitter unit 102.

[0081] In this manner, in cases, for example, when there is momentary movement or temporary dislodging of the sensor 101 from the initially positioned transcutaneous state, or when one or more of the contact points between sensor 101 and the transmitter unit 102 are temporarily disconnected, but otherwise, the sensor 101 is operational and within its useful life, the routine above provides an option to the user to maintain the usage of the sensor 101, without replacing the sensor 101 prior to the expiration of its useful life. In this manner, in one aspect, false positive indications of sensor 101 failure may be identified and addressed.

[0082] For example, FIG. 7 is a flowchart illustrating actual or potential sensor insertion or removal detection routine in accordance with one embodiment of the present disclosure. Referring to the Figure, the current analyte related signal is first compared to a predetermined signal characteristic (710). In one aspect, the predetermined signal characteristic may include one of a signal level transition from below a first predetermined level (for example, but not limited to 18 ADC (analog to digital converter) counts) to above the first predetermined level, a signal level transition from above a second predetermined level (for example, but not limited to 9 ADC counts) to below the second predetermined level, a transition from below a predetermined signal rate of change threshold to above the predetermined signal rate of change threshold, and a transition from above the predetermined signal rate of change threshold to below the predetermined signal rate of change threshold.

[0083] In this manner, in one aspect of the present disclosure, based on a transition state of the received analyte related signals, it may be possible to determine the state of the analyte sensor (720), and based on which, the user or the patient may confirm whether the analyte sensor is in the desired or proper position, has been temporarily dislocated, or otherwise, removed from the desired insertion site so as to require a new analyte sensor.

[0084] In this manner, in one aspect, when the monitored signal from the sensor **101** crosses a transition level (**730**) (for example, from no or low signal level to a high signal level, or vice versa), the transmitter unit **102** may be configured to generate an appropriate output data associated with the sensor signal transition (**740**), for transmission to the receiver unit **104** (FIG. 1). Additionally, as discussed in further detail below, in another embodiment, the determination of whether the sensor **101** has crossed a transition level may be determined by the receiver/monitor unit **104/106** based, at least in part on the one or more signals received from the transmitter unit **102**.

[0085] FIG. 8 is a flowchart illustrating receiver unit processing corresponding to the actual or potential sensor insertion or removal detection routine of FIG. 7 in accordance with one embodiment of the present disclosure. Referring now to FIG. 8, when the receiver unit **104** receives the generated output data from the transmitter unit **102** (**810**), a corresponding operation state is associated with the received output data (**820**), for example, related to the operational state of the sensor **101**. Moreover, a notification associated with the sensor operation state is generated and output to the user on the display unit or any other suitable output segment of the receiver unit **104** (**830**). When a user input signal is received in response to the notification associated with the sensor state operation state (**840**), the receiver unit **104** is configured to execute one or more routines associated with the received user input signal (**850**).

[0086] That is, as discussed above, in one aspect, if the user confirms that the sensor **101** has been removed, the receiver unit **104** may be configured to terminate or deactivate alarm monitoring and glucose displaying functions. On the other hand, if the user confirms that a new sensor **101** has been positioned or inserted into the user, then the receiver unit **104** may be configured to initiate or execute routines associated with the new sensor insertion, such as, for example, calibration procedures, establishing calibration timer, and establishing sensor expiration timer.

[0087] In a further embodiment, based on the detected or monitored signal transition, the receiver/monitor unit may be configured to determine the corresponding sensor state without relying upon the user input or confirmation signal associated with whether the sensor is dislocated or removed from the insertion site, or otherwise, operating properly.

[0088] FIG. 9 is a flowchart illustrating data processing corresponding to the actual or potential sensor insertion or removal detection routine in accordance with another embodiment of the present disclosure. Referring to FIG. 9, a current analyte related signal is received and compared to a predetermined signal characteristic (**910**). Thereafter, an operational state associated with an analyte monitoring device such as, for example, the sensor **101** (FIG. 1) is retrieved (**920**) from a storage unit or otherwise resident in, for example, a memory of the receiver/monitor unit. Additionally, a prior analyte related signal is also retrieved from the storage unit, and compared to the current analyte related signal received (**930**). An output data is generated which is associated with the operational state (**940**), and which at least in part is based on the one or more of the received current analyte related signal and the retrieved prior analyte related signal.

[0089] Referring again to FIG. 9, when the output data is generated, a corresponding user input command or signal is received in response to the generated output data (**950**),

which may include one or more of a confirmation, verification, or rejection of the operational state related to the analyte monitoring device.

[0090] FIG. 10 is a flowchart illustrating a concurrent passive notification routine in the data receiver/monitor unit of the data monitoring and management system of FIG. 1 in accordance with one embodiment of the present disclosure. Referring to FIG. 10, a predetermined routine is executed for a predetermined time period to completion (**1010**). During the execution of the predetermined routine, an alarm condition is detected (**1020**), and when the alarm or alert condition is detected, a first indication associated with the detected alarm or alert condition is output concurrent to the execution of the predetermined routine (**1030**).

[0091] That is, in one embodiment, when a predefined routine is being executed, and an alarm or alert condition is detected, a notification is provided to the user or patient associated with the detected alarm or alert condition, but which does not interrupt or otherwise disrupt the execution of the predefined routine. Referring back to FIG. 10, upon termination of the predetermined routine, another output or second indication associated with the detected alarm condition is output or displayed (**1040**).

[0092] More specifically, in one aspect, the user interface notification feature associated with the detected alarm condition is output to the user only upon the completion of an ongoing routine which was in the process of being executed when the alarm condition is detected. As discussed above, when such alarm condition is detected during the execution of a predetermined routine, a temporary alarm notification such as, for example, a backlight indicator, a text output on the user interface display or any other suitable output indication may be provided to alert the user or the patient of the detected alarm condition substantially in real time, but which does not disrupt an ongoing routine.

[0093] Within the scope of the present disclosure, the ongoing routine or the predetermined routine being executed may include one or more of performing a finger stick blood glucose test (for example, for purposes of periodically calibrating the sensor **101**), or any other processes that interface with the user interface, for example, on the receiver/monitor unit **104/106** (FIG. 1) including, but not limited to the configuration of device settings, review of historical data such as glucose data, alarms, events, entries in the data log, visual displays of data including graphs, lists, and plots, data communication management including RF communication administration, data transfer to the data processing terminal **105** (FIG. 1), or viewing one or more alarm conditions with a different priority in a preprogrammed or determined alarm or notification hierarchy structure.

[0094] In this manner, in one aspect of the present disclosure, the detection of one or more alarm conditions may be presented or notified to the user or the patient, without interrupting or disrupting an ongoing routine or process in, for example, the receiver/monitor unit **104/106** of the data monitoring and management system **100** (FIG. 1).

[0095] Referring now back to the Figures, FIG. 11 is a flowchart illustrating a data quality verification routine in accordance with one embodiment of the present disclosure. Referring to FIG. 11, initially the data quality status flags are cleared or initialized or reset (**1110**). Thereafter, data quality checks or verifications are performed, for example, as described above (**1120**). Thereafter, data quality flag is

generated and associated with the data packet when data quality check has failed (1130). In one aspect, the generated data quality flag may be based on data quality verification such that when the underlying condition being verified is determined to be acceptable, the data quality flag may return a value of zero (or one or more predetermined value). Alternatively, in the case where the underlying condition being verified is determined to be not within the acceptable criteria (or above the acceptable level), the associated data quality flag may return a value of one (or one or more predetermined value associated with the determination of such condition).

[0096] Referring to FIG. 11, the data packet including the raw glucose data as well as the data quality flags are transmitted, for example, to the receiver/monitor unit 104/106 for further processing (1140). As described above, the data quality checks may be performed in the transmitter unit 102 (FIG. 1) and/or in the receiver/monitor unit 104/106 in the data monitoring and management system 100 (FIG. 1) in one aspect of the present disclosure.

[0097] FIG. 12 is a flowchart illustrating a rate variance filtering routine in accordance with one embodiment of the present disclosure. Referring to FIG. 12, when glucose related data is detected or received (1210), for example, for each predetermined time intervals such as every minute, every five minutes or any other suitable time intervals, a plurality of filtered values based on the received or detected glucose related data is determined (1220). For example, as discussed above, in one aspect, using, for example, an FIR filter, or based on a weighted average, a plurality of filtered values for a 15 minute and two minute glucose related data including the currently received or detected glucose related are determined.

[0098] Referring back to FIG. 12, weighting associated with the plurality of filtered values is determined (1230). Thereafter, a rate of change of the glucose level based in part on the detected or received glucose related data is determined as well as a standard deviation of the rate of change based on the glucose related data (1240). Further, a weighted average associated with the current detected or monitored glucose related data is determined based on the plurality of filtered values and the determined standard deviation of the rate of change and/or the rate of change of the glucose level (1250). For example, when the rate of change is determined to be high relative to the rate of change variation, the filtered value based on the two minute data is weighted more heavily. On the other hand, when the rate of change is determined to be low relative to the rate of change variation, the filtered glucose related data includes the one of the plurality of filtered values based on the 15 minute data which is weighted more heavily. In this manner, in one aspect, there is provided a rate variance filtering approach which may be configured to dynamically modify the weighting function or data filtering to, for example, reduce undesirable variation in glucose related signals due to factors such as noise.

[0099] FIG. 13 is a flowchart illustrating a composite sensor sensitivity determination routine in accordance with one embodiment of the present disclosure. Referring to FIG. 13, during scheduled calibration time periods or otherwise manual calibration routines to calibrate the analyte sensor, when a current blood glucose value is received or detected (1310), a current or present sensitivity is determined based on the detected blood glucose value (1320). For example,

the current sensitivity may be determined by taking a ratio of the current glucose sensor value and the detected blood glucose value.

[0100] Referring to FIG. 13, a prior sensitivity previously determined is retrieved, for example, from the storage unit (1330). In one aspect, the prior sensitivity may include a previous sensitivity determined during a prior sensor calibration event, or may be based on the nominal sensor sensitivity based on the sensor code from manufacturing, for example. Returning again to FIG. 13, a first weighted parameter is applied to the current sensitivity, and a second weighted parameter is applied to the retrieved prior sensitivity (1340). For example, based on the time lapsed between the calibration event associated with the retrieved prior sensitivity value and the current calibration event (associated with the current or received blood glucose value), the first and second weighted parameters may be modified (e.g., increased or decreased in value) to improve accuracy.

[0101] Referring back to FIG. 13, based on applying the first and the second weighted parameters to the current sensitivity and the retrieved prior sensitivity, a composite sensitivity associated with the analyte sensor for the current calibration event is determined (1350). For example, using a time based approach, in one embodiment, the sensitivity associated with the analyte sensor for calibration may be determined to, for example, reduce calibration errors or accommodate sensitivity drift.

[0102] FIG. 14 is a flowchart illustrating an outlier data point verification routine in accordance with one embodiment of the present disclosure. Referring to FIG. 14, and as discussed in detail above, in determining composite sensitivity associated with the analyte sensor calibration, in one aspect, an outlier data point may be detected and accordingly corrected. For example, in one aspect, two successive sensitivities associated with two successive calibration events for the analyte sensor is compared (1410). If it is determined that the comparison between the two sensitivities are within a predetermined range (1420), the composite sensitivity for the current calibration of the analyte sensor is determined based on the two successive sensitivity values (1430), using, for example, the weighted approach described above.

[0103] Referring back to FIG. 14, if it is determined that the comparison of the two successive sensitivities results in the compared value being outside of the predetermined range, then the user may be prompted to enter or provide a new current blood glucose value (for example, using a blood glucose meter) (1440). Based on the new blood glucose value received, an updated or new sensitivity associated with the analyte sensor is determined (1450). Thereafter, the new or updated sensitivity determined is compared with the two prior sensitivities compared (at 1420) to determine whether the new or updated sensitivity is within a predefined range of either of the two prior sensitivities (1460). If it is determined that the new or updated sensitivity of the analyte sensor is within the predefined range of either of the two prior successive sensitivities, a composite sensitivity is determined based on the new or updated sensitivity and the one of the two prior successive sensitivities within the defined range of which the new or updated sensitivity is determined (1470). On the other hand, if it is determined that the new or updated sensitivity is not within the predefined

range of either of the two prior sensitivities, then the routine repeats and prompts the user to enter a new blood glucose value (1440).

[0104] FIG. 15 is a flowchart illustrating a sensor stability verification routine in accordance with one embodiment of the present disclosure. Referring to FIG. 15, and as discussed above, between predetermined or scheduled baseline calibration events to calibrate the sensor, the analyte sensor sensitivity stability may be verified, to determine, for example, if additional stability calibrations may be needed prior to the subsequent scheduled baseline calibration event.

[0105] For example, referring to FIG. 15, in one embodiment, after the second baseline calibration event to calibrate the analyte sensor, the user may be prompted to provide a new blood glucose value. With the current blood glucose value received (1510), the current sensor sensitivity is determined (1520). Thereafter, the most recent stored sensor sensitivity value from prior calibration event is retrieved (for example, from a storage unit) (1530), and the determined current sensor sensitivity is compared with the retrieved stored sensor sensitivity value to determine whether the difference, if any, between the two sensitivity values are within a predefined range (1540).

[0106] Referring back to FIG. 15, if it is determined that the difference between the current and retrieved sensitivity values are within the predefined range, then the stability associated with the sensor sensitivity is confirmed (1550), and no additional calibration is required prior to the subsequent scheduled baseline calibration event. On the other hand, if it is determined that the difference between the current sensitivity and the retrieved prior sensitivity is not within the predefined range, then after a predetermined time period has lapsed (1560), the routine returns to the beginning and prompts the user to enter a new blood glucose value to perform the stability verification routine.

[0107] In this manner, in one aspect, the stability checks may be performed after the outlier check is performed, and a new composite sensitivity determined as described above. Accordingly, in one aspect, analyte sensor sensitivity may be monitored as the sensitivity attenuation is dissipating to, among others, improve accuracy of the monitored glucose data and sensor stability.

[0108] FIG. 16 illustrates analyte sensor code determination in accordance with one embodiment. Referring to the Figure, a batch of predetermined number of analyte sensors, for example, glucose sensors are selected during the manufacturing process (1610). The batch of predetermined number of glucose sensors may be a set number, or a variable number depending upon other manufacturing or post-manufacturing parameters (for example, such as testing, quality control verification, or packaging).

[0109] Referring to FIG. 16, the sensitivity of each selected glucose sensor is determined (1620). For example, in one aspect, in vitro sensitivity determination is performed for each selected glucose sensor to determine the corresponding sensitivity. Thereafter, a variation between the determined sensitivity of each glucose sensor is determined (1630). That is, in one aspect, the determined in vitro sensitivity associated with each selected glucose sensor is compared to a predefined variation tolerance level (1640).

[0110] In one aspect, if the variation of the sensitivity is greater than the predefined variation tolerance level for one of the selected glucose sensors in the selected batch of predetermined number of glucose sensors (1660), then the

entire batch or lot may be rejected and not used. In another aspect, the rejection of the selected batch of predetermined number of glucose sensors may be based on a predetermined number of sensors within the selected batch that are associated with a sensitivity value that exceeds the predefined variation tolerance level. For example, in a batch of 30 glucose sensors, if 10 percent (or 3 sensors) has sensitivity that exceeds the predefined variation tolerance level, then the entire batch of 30 glucose sensors is rejected and not further processed during the manufacturing routine, for example, for use. Within the scope of the present disclosure, the number of sensors in the selected batch, or the number of sensors within the selected batch that exceeds the predefined variation tolerance level to result in a failed batch may be varied depending upon, for example, but not limited to, sensor manufacturing process, sensor testing routines, quality control verification, or other parameters associated with sensor performance integrity.

[0111] Referring back to FIG. 16, if it is determined that the sensitivity of the selected glucose sensors are within the predefined variation tolerance level, a nominal sensitivity is determined for the batch of the predetermined number of glucose sensors (1650). Further, a sensor code is associated with the determined nominal sensitivity for the batch of predetermined number of analyte sensors (1670).

[0112] In one aspect, the sensor code may be provided on the labeling for the batch of glucose sensors for use by the patient or the user. For example, in one aspect, the analyte monitoring system may prompt the user to enter the sensor code into the system (for example, to the receiver unit 104/106 FIG. 1) after the sensor has been initially positioned in the patient and prior to the first sensor calibration event. In a further aspect, based on the sensor code, the analyte monitoring system may be configured to retrieve the nominal sensitivity associated with the batch of predetermined number of sensors for, for example, calibration of the transcutaneously positioned glucose sensor.

[0113] FIG. 17 illustrates an early user notification function associated with the analyte sensor condition in one aspect of the present disclosure. Referring to FIG. 17, upon detection of the sensor insertion (1710), for example, in fluid contact with the patient or user's analyte (e.g., interstitial fluid), one or more adverse data condition occurrence associated with the patient or the user's analyte level is monitored (1720). Examples of the adverse data condition occurrence may include, for example, a persistent low sensor signal (for example, continuous for a predefined time period), identified data quality flags or identifiers associated with erroneous or potentially inaccurate sensor signal level or sensor condition (for example, dislodged or improperly positioned sensor).

[0114] Referring to FIG. 17, when it is determined that the monitored adverse data condition occurrence exceeds a predetermined number of occurrences during a predefined time period (1730), a notification is generated and provided to the user to either replace the sensor, or to perform one or more verifications to confirm, for example, but not limited to, that the sensor is properly inserted and positioned, so the transmitter unit is in proper contact with the sensor (1740).

[0115] On the other hand, if the number of adverse data condition occurrence has not occurred during the predefined time period, in one aspect, the routine continues to monitor for the occurrence of such condition during the set time period. In one aspect, the predetermined time period during

which the occurrence of adverse data condition occurrence may be approximately one hour from the initial sensor positioning. Alternatively, this time period may be shorter or longer, depending upon the particular system configuration.

[0116] In this manner, in the event that adverse condition related to the sensor is determined and persists for a given time period from the initial sensor insertion, the user or the patient is notified to either replace the sensor or to perform one or more troubleshooting steps to make sure that the components of the analyte monitoring system are functioning properly. Indeed, in one aspect, when an adverse condition related to the sensor is identified early on, the user is not inconvenienced by continuing to maintain the sensor in position even though the sensor may be defective or improperly positioned, or is associated with one or more other adverse conditions that will not allow the sensor to function properly.

[0117] FIG. 18 illustrates uncertainty estimation associated with glucose level rate of change determination in one aspect of the present disclosure. Referring to FIG. 18, based on the monitored glucose level from the glucose sensor, a rate of change estimate of the glucose level fluctuation is determined (1810). Further, an estimation of an uncertainty range or level associated with the determined rate of change of the glucose level is determined (1820). That is, in one aspect, a predefined rate of uncertainty determination may be performed, such as for example, a rate of change variance calculation. If the uncertainty determination is within a predetermined threshold level (1830), then an output is generated and/or provided to the user (1840).

[0118] For example, when it is determined that the determined uncertainty measure is within the threshold level, the analyte monitoring system may be configured to display or output an indication to the user or the patient, such as a glucose level trend indicator (for example, a visual trend arrow or a distinctive audible alert (increasing or decreasing tone, etc)). On the other hand, if it is determined that the uncertainty measure related to the rate of change estimate exceeds the predetermined threshold, the determined rate of change of glucose level may be rejected or discarded (or stored but not output to the user or the patient). In one aspect, the uncertainty measure may include a predefined tolerance parameter associated with the accuracy of the determined rate of change of the monitored glucose level.

[0119] In one aspect, the uncertainty measure or the tolerance level related to the rate of change of monitored glucose level may include, for example, but not limited to, corrupt or erroneous data associated with the monitored glucose level, unacceptably large number of missing data associated with the monitored glucose level, rate of acceleration or deceleration of the monitored glucose level that exceeds a defined or acceptable threshold level, or any other parameters that may contribute to potential inaccuracy in the determined rate of change of the monitored glucose level.

[0120] Accordingly, in one aspect, the accuracy of the analyte monitoring system may be maintained by, for example, disabling the output function associated with the rate of change determination related to the monitored glucose level, so that the user or the patient does not take corrective actions based on potentially inaccurate information. That is, as discussed above, in the event when it is determined that the determined uncertainty measure or parameter exceeds an acceptable tolerance range, the output function on the receiver unit 104/106 in the analyte moni-

toring system 100 may be disabled temporarily, or until the uncertainty measure of parameter related to the rate of change of the glucose level being monitored is within the acceptable tolerance range.

[0121] When the monitored rate of change of the glucose level is steady (or within a defined range) and medically significant with respect to the monitored glucose measurement, a prediction of future or anticipated glucose level may be considered reliable based on the determined rate of change level. However, the monitored glucose level time series is such that the determined rate of change estimate may be less certain.

[0122] Accordingly, in one aspect, the present disclosure accounts for the rate of change estimates having varying degrees of certainty. Since clinical treatment decisions may be made based on these estimates, it is important to discount, or not display or output to the user, the determined rate of change estimates with a high degree of uncertainty.

[0123] In one aspect, the rate of change value and its uncertainty determine a probability distribution. This distribution may be assumed to be Gaussian, for example. Within the scope of the present disclosure, the uncertainty measure may be calculated in various ways. In one embodiment, it may include a standard deviation determination. Another possibility is to use the coefficient of variation (CV), which is the standard deviation of the rate of change divided by the rate of change. A combination of these uncertainty measures may also be used.

[0124] In one aspect, various ranges of rates of change may be combined into bins. For example, bin edges at ± 2 mg/dL and at ± 1 mg/dL may be defined in one embodiment resulting in five bins. Each bin may be represented by a position of a trend arrow indicator, associated with the monitored glucose level. When the rate of change is included in one of the determined bins, the associated trend arrow position may be displayed.

[0125] Further, the presence of uncertainty may modify the trend arrow position that is displayed to the user or the patient. In one aspect, a determination that involves the uncertainty measure results in a metric value which may be a simple comparison of the uncertainty value to a predefined threshold. There are also other possible metrics. Another approach may use a different predefined threshold value for each bin.

[0126] In one aspect, an unacceptable metric value may cause no trend arrow indicator to be displayed. Alternatively, this condition may be indicated by a change in the characteristics of the display to the user or the patient. For example, the trend arrow indicator may flash, change color, change shape, change size, change length or change width, among others. A further embodiment may include the trend arrow indicator showing no significant rate-of-change. Within the scope of the present disclosure, other user output configurations including audible and/or vibratory output are contemplated.

[0127] In one aspect, the uncertainty measure may be characterized a number of ways. One is the standard deviation of the monitored glucose levels over the period in which the rate of change is estimated. Another is the coefficient of variation (CV), which, as discussed above, is the standard deviation of the monitored glucose trend divided by the rate of change value. A further characterization may include a probabilistic likelihood estimate. Yet a further characterization is the output of a statistical filter or estimator such as a

Kalman filter. The uncertainty comparison may be based on one of these techniques or a combination of two or more of these techniques. Also, different uncertainty characteristics may be used for different rate-of-change results. For instance, in one embodiment, a CV formulation may be used for high glucose values and a standard deviation formulation may be used for low glucose values.

[0128] FIG. 19 illustrates glucose trend determination in accordance with one embodiment of the present disclosure. Referring to FIG. 19, a current value associated with a monitored glucose level is received (1910). One or more prior values associated with the monitored glucose level (previously stored, for example) is retrieved (1920). With the current and prior values associated with the monitored glucose level, a most recent calibration scale factor is applied to the current and prior values associated with the monitored glucose level (1930). After applying the calibration scale factor to the current and prior values, the trend associated with the monitored glucose level is determined (1940).

[0129] In this manner, in one aspect, with the updated calibration of the glucose sensor including a newly determined sensitivity, buffered or stored values associated with the monitored glucose level may be updated using, for example, the updated calibration information, resulting, for example, in revised or modified prior values associated with the monitored glucose level. As such, in one embodiment, stored or buffered values associated with the monitored glucose level may be updated and, the updated values may be used to determine glucose trend information or rate of change of glucose level calculation. In this manner, accuracy of the glucose trend information may be improved by applying the most recent calibration parameters to previously detected and stored values associated with the monitored glucose level, when, for example, the previously detected and stored values are used for further analysis, such as, glucose trend determination or rate of change of glucose level calculation.

[0130] FIG. 20 illustrates glucose trend determination in accordance with another embodiment of the present disclosure. Referring to FIG. 20, a current value associated with a monitored glucose level is received (2010). One or more prior values associated with the monitored glucose level (previously stored, for example) is retrieved (2020). With the current and prior values associated with the monitored glucose level, a rate of change estimate of the monitored glucose level is determined (2030). Referring back to FIG. 20, an uncertainty parameter associated with the rate of change estimate is determined (2040).

[0131] In one aspect, an uncertainty parameter may be predetermined and programmed into the analyte monitoring system 100 (for example, in the receiver unit 104/106). Alternatively, the uncertainty parameter may be dynamically configured to vary depending upon the number of data available for determination of the glucose level rate of change determination, or upon other programmable parameters that may include user specified uncertainty parameters. Within the scope of the present disclosure, the uncertainty parameter may include the number of acceptable missing or unavailable values when performing the monitored glucose level rate of change estimation. Referring back to FIG. 20, when it is determined that the uncertainty parameter is within an acceptable predetermined tolerance range, the rate

of change of the monitored glucose level is determined and output to the user or the patient (2050).

[0132] In one embodiment, the uncertainty parameter may be associated with the time spacing of the current and prior values, such that when the rate of change estimation requires a preset number of values, and no more than a predetermined number of values (optionally consecutively, or non consecutively) are unavailable, the rate of change estimation is performed. In this manner, for example, when a large number of values associated with the monitored glucose level (for example, 5 consecutive one minute data—tolerance range) are unavailable, corrupt or otherwise unusable for purposes of rate of change determination, the uncertainty parameter is deemed to exceed the predetermined tolerance range, and the rate of change calculation may not be performed, or may be postponed.

[0133] As discussed, the rate of change in glucose for a patient or a user may be used by glucose monitoring devices to direct glucose trend indicators for display to the patient or the user such that the patient or the user may base treatment decisions not only on the current glucose levels but also on the current direction or change in the glucose level. The rate of change estimate may also be used to project into the future if a predetermined glucose threshold (upper or lower range or limit) is not exceeded within a specific time period based on the current glucose level and rate of change information. Within the scope of the present disclosure, other projection approaches may be based on higher order derivatives of the rate of change, and/or other statistical likelihood formulations that can be contemplated for prediction of a future event.

[0134] One approach to determine the rate of change is to calculate the difference between two glucose samples and dividing the result by the time difference between the samples. Another approach may be to fit a time series of glucose readings to a function, such as a polynomial, using techniques such as the least squares techniques. The number of samples and the time period of the samples may impact the accuracy of the rate of change estimate in the form of a trade off between noise reduction properties and lag introduced.

[0135] Referring again to the Figures, in one aspect, the transmitter unit 102 may be configured to perform one or more periodic or routine data quality checks or verification before transmitting the data packet to the receiver/monitor unit 104/106. For example, in one aspect, for each data transmission (e.g., every 60 seconds, or some other predetermined transmission time interval), the transmitter data quality flags in the data packet are reset, and then it is determined whether any data field in the transmission data packet includes an error flag. If one error flag is detected, then in one aspect, the entire data packet may be considered corrupt, and this determination is transmitted to the receiver/monitor unit 104/106. Alternatively, the determination that the entire data packet is corrupt may be performed by the receiver/monitor unit 104/106. Accordingly, in one aspect, when at least one data quality check fails in the transmitter data packet, the entire packet is deemed to be in error, and the associated monitored analyte level is discarded, and not further processed by the receiver/monitor unit 104/106.

[0136] In another aspect, the data quality check in the transmitter unit 102 data packet may be performed so as to identify each error flag in the data packet, and those identified error flag are transmitted to the receiver/monitor unit

104/106 in addition to the associated monitored analyte level information. In this manner, in one aspect, if the error flag is detected in the transmitter data packet which is not relevant to the accuracy of the data associated with the monitored analyte level, the error indication is flagged and transmitted to the receiver/monitor unit **104/106** in addition to the data indicating the monitored analyte level.

[0137] In one aspect, examples of error condition that may be detected or flagged in the transmitter unit **102** data packet include sensor connection fault verification by, for example, determining, among others, whether the counter electrode voltage signal is within a predetermined range, resolution of the data associated with the monitored analyte level, transmitter unit temperature (ambient and/or on-skin temperature) out of range, and the like. As discussed above, the data quality check in the transmitter unit **102** may be performed serially, such that detection of an error condition or an error flag renders the entire data packet invalid or deemed corrupt. In this case, such data is reported as including error to the receiver/monitor unit **104/106**, but not used to process the associated monitored analyte level. In another aspect, all data quality fields in the data packet of the transmitter unit **102** may be checked for error flags, and if there are error flags detected, the indication of the detected error flags is transmitted with the data packet to the receiver/monitor unit **104/106** for further processing.

[0138] In one embodiment, on the receiver/monitor unit **104/106** side, for each periodic data packet received (for example every 60 seconds or some other predetermined time interval), the receiver/monitor unit **104/106** may be configured to receive the raw glucose data including any data quality check flags from the transmitter unit **102**, and to apply temperature compensation and/or calibration to the raw data to determine the corresponding glucose data (with any data quality flags as may have been identified). The unfiltered, temperature compensated and/or calibrated glucose data is stored along with any data quality flags in a FIFO buffer (including, for example, any invalid data identifier). Alternatively, a further data quality check may be performed on the temperature compensated and calibrated glucose data to determine the rate of change or variance of the measured glucose data. For example, in one embodiment, a high variance check or verification is performed on 30 minutes of glucose data stored in the FIFO buffer. If it is determined that the rate of variance exceeds a predetermined threshold, then the data packet in process may be deemed invalid. On the other hand, if the rate of variance does not exceed the predetermined threshold, the results including the glucose data and any associated validity or error flags are stored in the FIFO buffer.

[0139] Thereafter, the data processing is performed on the stored data to determine, for example, the respective glucose level estimation or calculation. That is, the stored data in the FIFO buffer in one embodiment is filtered to reduce unwanted variation in signal measurements due to noise or time delay, among others. In one aspect, when the rate of change or variance of glucose data stored in the FIFO buffer, for example, is within a predetermined limit, the glucose measurements are filtered over a 15 minute period. On the other hand, if it is determined that the rate of change is greater than the predetermined limit, a more responsive 2 minute filtering is performed. In one aspect, the filtering is performed for each 60 second glucose data. In this manner, in one embodiment, a rate variance filter is provided that

may be configured to smooth out the variation in the glucose measurement when the glucose level is relatively stable, and further, that can respond quickly when the glucose level is changing rapidly. The rate variance filter may be implemented in firmware as an FIR filter which is stable and easy to implement in integer-based firmware, for example, implemented in fixed point math processor.

[0140] In one embodiment, for each 60 second glucose data received, two filtered values and two additional parameters are determined. That is, using an FIR filter, for example, a weighted average for a 15 minute filtered average glucose value and a 2 minute average filtered glucose value are determined. In addition, a rate of change based on 15 minutes of data as well as a standard deviation associated with the rate estimate is determined. To determine the final filtered glucose value for output and/or display to the user, a weighted average of the two determined filtered glucose values is determined, where when the rate of change of the glucose values is high, then weighting is configured to tend towards the 2 minute filtered value, while when the rate of change of the glucose value is low the weighting tends towards the 15 minute filtered value. In this manner, when the rate of change is high, the 2 minute filtered value is weighted more heavily (as the 15 minute filtered average value potentially introduces lag, which at higher rates of change, likely results in large error).

[0141] Referring back, during the calibration routine, in one embodiment, when the discrete blood glucose value is received for purposes of calibration of the glucose data from the sensor **101** (FIG. 1), the processing unit of the receiver/monitor unit **104/106** is configured to retrieve from the FIFO buffer two of the last five valid transmitter data packets that do not include any data quality flags associated with the respective data packets. In this manner, in one aspect, the calibration validation check may be performed when the blood glucose value is provided to the receiver/monitor unit **104/106** determined using, for example, a blood glucose meter. In the event that two valid data packets from the last five data packets cannot be determined, the receiver/monitor unit **104/106** is configured to alarm or notify the user, and the calibration routine is terminated.

[0142] On the other hand, if the calibration validation check is successful, the sensitivity associated with the sensor **101** (FIG. 1) is determined, and its range verified. In one aspect, if the sensitivity range check fails, again, the receiver/monitor unit **104/106** may be configured to alarm or otherwise notify the user and terminate the calibration routine. Otherwise, the determined sensitivity is used for subsequent glucose data measurement and processing (until a subsequent calibration is performed).

[0143] Referring back to the Figures, in one aspect, determination of optimal sensitivity evaluates one or more potential error sources or conditions present in blood glucose value for calibration and the potential sensitivity drift. Accordingly, using a weighted average of the current sensitivity determined for calibration and previously determined sensitivity, the sensitivity accuracy may be optimized. For example, in one embodiment, a weighted average of the two most recent sensitivities determined used for calibration may be used to determine a composite sensitivity determination to improve accuracy and reduce calibration errors. In this aspect, earlier blood glucose values used for calibration are discarded to accommodate for sensitivity drift. In one embodiment, the number of blood glucose values used for

determining the weighted average, and also, the weighting itself may be varied using one or more approaches including, for example, a time based technique.

[0144] For example, for each sensor calibration routine, the sensitivity derived from the current blood glucose value from the current blood glucose test and the stored sensitivity value associated with the most recent prior stored blood glucose value may be used to determine a weighted average value that is optimized for accuracy. Within the scope of the present disclosure, as discussed above, the weighting routine may be time based such that if the earlier stored blood glucose value used for prior calibration is greater than a predetermined number of hours, then the weighting value assigned to the earlier stored blood glucose may be less heavy, and a more significant weighting value may be given to the current blood glucose value to determine the composite sensitivity value.

[0145] In one embodiment, a lookup table may be provided for determining the composite sensitivity determination based on a variable weighting average which provides a non-linear correction to reduce errors and improve accuracy of the sensor sensitivity.

[0146] The determined composite sensitivity in one embodiment may be used to convert the sensor ADC counts to the corresponding calibrated glucose value. In one aspect, the composite sensitivity determined may be used to minimize outlier calibrations and unstable sensitivity during, for example, the initial use periods. That is, during the data validation routines, an outlier check may be performed to determine whether the sensitivity associated with each successive calibration is within a predetermined threshold or range.

[0147] For example, the sensor **101** (FIG. 1) may require a predetermined number of baseline calibrations during its use. For a five day operational lifetime of a sensor, four calibrations may be required at different times during the five day period. Moreover, during this time period, additional stability related calibrations may be required if the sensor sensitivity is determined to be unstable after the second baseline calibration is performed, for example, at the 12th hour (or other suitable time frame) of the sensor usage after the initial calibration within the first 10 hours of sensor deployment.

[0148] In one aspect, during the outlier check routine, it is determined whether the sensitivity variance between two successive calibrations is within a predetermined acceptable range. If it is determined that the variance is within the predetermined range, then the outlier check is confirmed, and a new composite sensitivity value is determined based on a weighted average of the two sensitivity values. As discussed above, the weighted average may include a time based function or any other suitable discrete weighting parameters.

[0149] If on the other hand, the variance between the two sensitivities is determined to be outside of the predetermined acceptable range, then the second (more recent) sensitivity value is considered to be an outlier (for example, due to ESA, change in sensitivity or due to bad or erroneous blood glucose value), and the user is prompted to perform another fingerstick testing to enter a new blood glucose value (for example, using a blood glucose meter). If the second current sensitivity associated with the new blood glucose value is determined to be within the predetermined acceptable range from the prior sensitivity, then the earlier current sensitivity

value is discarded, and the composite sensitivity is determined based on applying a weighting function or parameter on the prior sensitivity value, and the second current sensitivity value (discarding the first current sensitivity value which is outside the predetermined acceptable range and considered to be an outlier).

[0150] On the other hand, when the second current sensitivity value is determined to be within the predetermined acceptable range of the first current sensitivity value, but not within the predetermined acceptable range of the prior sensitivity value (of the two successive calibrations described above), then it is determined in one embodiment that a sensitivity shift, rather than an outlier, has occurred or is detected from the first current sensitivity value to the second current sensitivity value. Accordingly, the composite sensitivity may be determined based, in this case, on the first and second current sensitivity values (and discarding the prior sensitivity).

[0151] If, for example, the second current sensitivity value is determined to be outside the predetermined range of both of the two successive sensitivities described above, then the user in one embodiment is prompted to perform yet another blood glucose test to input another current blood glucose value, and the routine described above is repeated.

[0152] Furthermore, in accordance with another aspect, the determination of the sensitivity variance between two successive calibrations is within a predetermined acceptable range may be performed prior to the outlier check routine.

[0153] Referring to the Figures, during the period of use, as discussed above, the sensor **101** (FIG. 1) is periodically calibrated at predetermined time intervals. In one aspect, after the second baseline calibration (for example, at 12th hour of sensor **101** transcutaneously positioned in fluid contact with the user's analyte), sensor sensitivity stability verifications may be performed to determine whether, for example, additional stability calibrations may be necessary before the third baseline calibration is due. In one aspect, the sensitivity stability verification may be performed after the outlier checks as described above is performed, and a new composite sensitivity is determined, and prior to the third scheduled baseline calibration at the 24th hour (or at another suitable scheduled time period).

[0154] That is, the sensor sensitivity may be attenuated (e.g., ESA) early in the life of the positioned sensor **101** (FIG. 1), and if not sufficiently dissipated by the time of the first baseline calibration, for example, at the 10th hour (or later), and even by the time of the second calibration at the 12th hour. As such, in one aspect, a relative difference between the two sensitivities associated with the two calibrations is determined. If the determined relative difference is within a predefined threshold or range (for example, approximately 26% variation), then it is determined that the sufficient stability point has been reached. On the other hand, if the relative difference determined is beyond the predefined threshold, then the user is prompted to perform additional calibrations at a timed interval (for example, at each subsequent 2 hour period) to determine the relative difference in the sensitivity and compared to the predefined range. This may be repeated for each two hour interval, for example, until acceptable stability point has been reached, or alternatively, until the time period for the third baseline calibration is reached, for example, at the 24th hour of sensor **101** (FIG. 1) use.

[0155] In this manner, in one aspect, the stability verification may be monitored as the sensitivity attenuation is dissipating over a given time period. While the description above is provided with particular time periods for baseline calibrations and additional calibration prompts for stability checks, for example, within the scope of the present disclosure, other time periods or calibration schedule including stability verifications may be used. In addition, other suitable predefined threshold or range of the relative sensitivity difference to determine acceptable attenuation dissipation other than approximately 26% may be used. Moreover, as discussed above, the predetermined calibration schedule for each sensor 101 (FIG. 1) may be modified from the example provided above, based on, for example, the system design and/or sensor 101 (FIG. 1) configuration.

[0156] Additionally, in one aspect, the user may be prompted to perform the various scheduled calibrations based on the calibration schedule provided. In the case where the scheduled calibration is not performed, in one embodiment, the glucose value determination for user display or output (on the receiver/monitor unit 104/106, for example) based on the received sensor data may be disabled after a predetermined time period has lapsed. Further, the glucose value determination may be configured to resume when the prompted calibration is successfully completed.

[0157] In a further aspect, the scheduled calibration timing may be relative to the prior calibration time periods, starting with the initial sensor positioning. That is, after the initial transcutaneous positioning of the sensor 101 (FIG. 1) and the scheduled time period has elapsed to allow the sensor 101 to reach a certain stability point, the user may be prompted to perform the first baseline calibration as described above (for example, at the 10th hour since the initial sensor placement). Thereafter, in the case when the user waits until the 11th hour to perform the initial baseline calibration, the second scheduled calibration at the 12th hour, for example, may be performed at the 13th hour, so that the two hour spacing between the two calibrations are maintained, and the second calibration timing is based on the timing of the first successful baseline calibration performed. In an alternate embodiment, each scheduled calibration time period may be based on the timing of the initial sensor positioning. That is, rather than determining the appropriate subsequent calibration time periods based on the prior calibration performed, the timing of the scheduled calibration time periods may be made to be absolute and based from the time of the initial sensor placement.

[0158] Furthermore, in one aspect, when the scheduled calibration is not performed at the scheduled time periods, the glucose values may nevertheless be determined based on the sensor data for display to the user for a limited time period (for example, for no more than two hours from when the scheduled calibration time period is reached). In this manner, a calibration time window may be established or provided to the user with flexibility in performing the scheduled calibration and during which the glucose values are determined for output display to the user, for example. In one aspect, if within the calibration time window, the scheduled calibrations are not performed, the glucose values may be deemed in error, and thus not provided to the user or determined until the calibration is performed.

[0159] For example, after the initial successful baseline calibration at the 10th hour, for example, or at any other suitable scheduled initial baseline calibration time, glucose

values are displayed or output to the user and stored in a memory. Thereafter, at the next scheduled calibration time period (for example, at the 12th hour), the user may be prompted to perform the second calibration. If the user does not perform the second calibration, a grace period of two hours, for example, is provided during which valid glucose values are provided to the user (for example, on the display unit of the receiver/monitor unit 104/106) based on the prior calibration parameters (for example, the initial baseline calibration performed at the 10th hour). However, if the second calibration is still not performed after the grace period, in one aspect, no additional glucose values are provided to user, and until the scheduled calibration is performed.

[0160] In still another aspect, the user may supplement the scheduled calibrations, and perform manual calibration based on the information that the user has received. For example, in the case that the user determines that the calibration performed and determined to be successful by the receiver/monitor unit 104/106, for example, is not sufficiently accurate, rather than replacing the sensor, the user may recalibrate the sensor even if the scheduled calibration time has not been reached. For example, based on a blood glucose test result, if the determined blood glucose level is not close to or within an acceptable range as compared to the sensor data, the user may determine that additional calibration may be needed.

[0161] Indeed, as the sensitivity value of a given sensor tends to stabilize over time, a manual user forced calibration later in the sensor's life may provide improved accuracy in the determined glucose values, as compared to the values based on calibrations performed in accordance with the prescribed or predetermined calibration schedule. Accordingly, in one aspect, additional manual calibrations may be performed in addition to the calibrations based on the predetermined calibration schedule.

[0162] In a further aspect, user notification functions may be programmed in the receiver/monitor unit 104/106, or in the transmitter unit 102 (FIG. 1) to notify the user of initial conditions associated with the sensor 101 (FIG. 1) performance or integrity. That is, alarms or alerts, visual, auditory, and/or vibratory may be configured to be triggered when conditions related to the performance of the sensor is detected. For example, during the initial one hour period (or some other suitable time period) from the sensor insertion, in the case where data quality flags/conditions (described above) are detected, or in the case where low or no signal from the sensor is detected from a given period of time, an associated alarm or notification may be initiated or triggered to notify the user to verify the sensor position, the sensor contacts with the transmitter unit 102 (FIG. 1), or alternatively, to replace the sensor with a new sensor. In this manner, rather than waiting a longer period until the acceptable sensor stability point has been reached, the user may be provided at an early stage during the sensor usage that the positioned sensor may be defective or has failed.

[0163] In addition, other detected conditions related to the performance of the sensor, calibration, and detected errors associated with the glucose value determination may be provided to the user using one or more alarm or alert features. For example, when the scheduled calibration has been timely performed, and the grace period as described above has expired, in one embodiment, the glucose value is not processed for display or output to the user anymore. In

this case, an alarm or alert notifying the user that the glucose value cannot be calculated is provided so that the user may timely take corrective actions such as performing the scheduled calibration. In addition, when other parameters that are monitored such as the temperature, sensor data, and other variables that are used to determine the glucose value, include error or otherwise is deemed to be corrupt, the user may be notified that the associated glucose value cannot be determined, so that the user may take corrective actions such as, for example, replacing the sensor, verifying the contacts between the sensor and the transmitter unit, and the like.

[0164] In this manner, in one embodiment, there is provided an alarm or notification function that detects or monitors one or more conditions associated with the glucose value determination, and notifies the user of the same when such condition is detected. Since the alarms or notifications associated with the glucose levels (such as, for example, alarms associated with potential hyperglycemic, hypoglycemic, or programmed trend or rate of change glucose level conditions) will be inactive if the underlying glucose values cannot be determined, by providing a timely notification or alarm to the user that the glucose value cannot be determined, the user can determine or be prompted/notified that these alarms associated with glucose levels are inactive.

[0165] In one aspect of the present disclosure, glucose trend information may be determined and provided to the user, for example, on the receiver/monitor unit **104/106**. For example, trend information in one aspect is based on the prior monitored glucose levels. When calibration is performed, the scaling used to determine the glucose levels may change. If the scaling for the prior glucose data (for example, one minute prior) is not changed, then in one aspect, the trend determination may be deemed more error prone. Accordingly, in one aspect, to determine accurate and improved trend determination, the glucose level determination is performed retrospectively for a 15 minute time interval based on the current glucose data when each successive glucose level is determined.

[0166] That is, in one aspect, with each minute determination of the real time glucose level, to determine the associated glucose trend information, the stored past 15 minute data associated with the determined glucose level is retrieved, including the current glucose level. In this manner, the buffered prior glucose levels may be updated with new calibration to improve accuracy of the glucose trend information.

[0167] In one aspect, the glucose trend information is determined based on the past 15 minutes (or some other predetermined time interval) of glucose data including, for example, the current calibration parameter such as current sensitivity. Thereafter, when the next glucose data is received (at the next minute or based on some other timed interval), a new sensitivity is determined based on the new data point associated with the new glucose data. Also, the trend information may be determined based on the new glucose data and the past 14 minutes of glucose data (to total 15 minutes of glucose data). It is to be noted that while the trend information is determined based on 15 minutes of data as described above, within the scope of the present disclosure, other time intervals may be used to determine the trend information, including, for example, 30 minutes of glucose data, 10 minutes of glucose data, 20 minutes of glucose data, or any other appropriate time intervals to attain an accurate estimation of the glucose trend information.

[0168] In this manner, in one aspect of the present disclosure, the trend information for the historical glucose information may be updated based on each new glucose data received, retrospectively, based on the new or current glucose level information, and the prior 14 glucose data points (or other suitable number of past glucose level information). In another aspect, the trend information may be updated based on a select number of recent glucose level information such that, it is updated periodically based on a predetermined number of determined glucose level information for display or output to the user.

[0169] In still another aspect, in wireless communication systems such as the data monitoring and management system **100** (FIG. 10), the devices or components intended for wireless communication may periodically be out of communication range. For example, the receiver/monitor unit **104/106** may be placed out of the RF communication range of the transmitter unit **102** (FIG. 1). In such cases, the transmitted data packet from the transmitter unit **102** may not be received by the receiver/monitor unit **104/106**, or due to the weak signaling between the devices, the received data may be invalid or corrupt. In such cases, while there may be missing data points associated with the periodically monitored glucose levels, the trend information may be nevertheless determined, as the trend information is determined based on a predetermined number of past or prior glucose data points (for example, the past 15 minutes of glucose data).

[0170] That is, in one aspect, even if there are a certain number of glucose data points within the 15 minute time frame that may be either not received by the receiver/monitor unit **104/106**, or alternatively be corrupt or otherwise invalid due to, for example, weakness in the communication link, the trend information may be determined. For example, given the 15 minutes of glucose data, if three or less non consecutive data points are not received or otherwise corrupt, the receiver/monitor unit **104/106** may determine the glucose trend information based on the prior 12 glucose data points that are received and considered to be accurate. As such, the features or aspects of the analyte monitoring system which are associated with the determined trend information may continue to function or operate as programmed.

[0171] That is, the projected alarms or alerts programmed into the receiver/monitor unit **104/106**, or any other alarm conditions associated with the detection of impending hyperglycemia, impending hypoglycemia, hyperglycemic condition or hypoglycemic condition (or any other alarm or notification conditions) may continue to operate as programmed even when there are a predetermined number or less of glucose data points. However, if and when the number of missing glucose data points exceed the tolerance threshold so as to accurately estimate or determine, for example, the glucose trend information, or any other associated alarm conditions, the display or output of the associated glucose trend information or the alarm conditions may be disabled.

[0172] For example, in one aspect, the glucose trend information and the rate of change of the glucose level (which is used to determine the trend information) may be based on 15 minute data (or data based on any other suitable time period) of the monitored glucose levels, where a predetermined number of missing data points within the 15 minutes may be tolerated. Moreover, using least squares

approach, the rate of change of the monitored glucose level may be determined to estimate the trend, where the monitored glucose data is not evenly spaced in time. In this approach, the least squares approach may provide an uncertainty measure of the rate of change of the monitored glucose level. The uncertainty measure, in turn, may be partially dependent upon the number of data points available.

[0173] Indeed, using the approaches described above, the trend information or the rate of change of the glucose level may be estimated or determined without the need to determine which data point or glucose level is tolerable, and which data point is not tolerable. For example, in one embodiment, the glucose data for each minute including the missing data is retrieved for a predetermined time period (for example, 15 minute time period). Thereafter, least squares technique is applied to the 15 minute data points. Based on the least squares (or any other appropriate) technique, the uncertainty or a probability of potential variance or error of the rate of glucose level change is determined. For example, the rate of change may be determined to be approximately $1.5 \text{ mg/dL/minute} \pm 0.1 \text{ mg/dL/minute}$. In such a case, the 0.1 mg/dL/minute may represent the uncertainty information discussed above, and may be higher or lower depending upon the number of data points in the 15 minutes of data that are missing or corrupt.

[0174] In this manner, in one aspect, the glucose trend information and/or the rate of change of monitored glucose level may be determined based on a predefined number of past monitored glucose level data points, even when a subset of the predefined number of past monitored glucose level data points are missing or otherwise determined to be corrupt. On the other hand, when the number of past glucose level data points based on which the glucose trend information is determined, exceeds the tolerance or acceptance level, for example, the display or output of the glucose trend information may be disabled. Additionally, in a further aspect, if it is determined that the underlying data points associated with the monitored glucose level based on which the trend information is determined, includes uncertainty or error factor that exceeds the tolerance level (for example, when there are more than a predetermined number of data points which deviate from a predefined level), the receiver/monitor unit **104/106**, for example, may be configured to disable or disallow the display or output of the glucose trend information.

[0175] For example, when the 15 minute glucose data including the current glucose level as well as the past 14 minutes of glucose level data is to be displayed or output to the user, and the determined rate variance of the 15 data points exceeds a preset threshold level (for example, 3.0), the glucose trend information display function may be disabled. In one aspect, the variance may be determined based on the square function of the standard deviation of the 15 data points. In one aspect, this approach may be performed substantially on a real time basis for each minute glucose data. Accordingly, as discussed above, the glucose trend information may be output or displayed substantially in real time, and based on each new glucose data point received from the sensor/transmitter unit.

[0176] Additionally, when it is determined that the 15 data points (or any other suitable number of data points for determining glucose trend information, for example), deviate beyond a predetermined tolerance range, in one aspect,

the 15 minute data may be deemed error prone or inaccurate. In this case, rather than outputting or displaying glucose trend information that may be erroneous, the receiver/monitor unit **104/106** may be configured to display the output or display function related to the output or display of the determined glucose trend information. The same may apply to the output or display of projected alarms whose estimates may be based in part, on the determined trend information. Accordingly, in one aspect, there may be instances when the projected alarm feature may be temporarily disabled where the underlying monitored glucose data points are considered to include more than acceptable levels of uncertainty or error.

[0177] In a further aspect, it is desired to determine an estimate of sensor sensitivity, and/or a range of acceptable or reasonable sensitivity. For example, during determination or verification of the glucose rate of change prior to calibration, the estimated sensor sensitivity information is necessary, for example, to determine whether the rate of change is within or below an acceptable threshold level, and/or further, within a desired range. Moreover, when determining whether the sensor sensitivity is within an acceptable or reasonable level, it may be necessary to ascertain a range of reasonable or acceptable sensitivity—for example, a verification range for the sensitivity value for a given sensor or batch of sensors.

[0178] Accordingly, in one aspect, during sensor manufacturing process, a predetermined number of sensor samples (for example, 16 samples) may be evaluated from each manufacturing lot of sensors (which may include, for example, approximately 500 sensors) and the nominal sensitivity for each lot (based, for example, on a mean calculation) may be determined. For example, during the manufacturing process, the predetermined number of sensors (for example, the 16 sensors) is sampled, and the sensitivity of each sampled sensor is measured in vitro. Thereafter, a mean sensitivity may be determined as an average value of the 16 sampled sensor's measured sensitivity, and thereafter, the corresponding sensor code is determined where the determined mean sensitivity falls within the preassigned sensitivity range. Based on the determined sensor code, the sensor packaging is labeled with the sensor code.

[0179] For example, each sensor code value (e.g., 105, 106, 107 or any suitable predetermined number or code) may be preassigned a sensitivity range (For example, code 105: S1-S2, code 106: S2-S3, and code 107: S3-S4), where each sensitivity range (e.g., S1-S2, or S2-S3, or S3-S4) is approximately over a 10 percent increment (for example, S1 is approximately 90% of S2). Also, each sensor code (e.g., **105, 106, 107** etc) is assigned a nominal sensitivity value (S_n) that is within the respective preassigned sensitivity range.

[0180] Referring back, when the user inserts the sensor or positions the sensor transcutaneously in place, the receiver/monitor unit **104/106** in one embodiment prompts the user to enter the associated sensor code. When the user enters the sensor code (as derived from the sensor packing label discussed above), the receiver/monitor unit **104/106** is configured to retrieve or look up the nominal sensitivity associated with the user input sensor code (and the nominal sensitivity which falls within the preassigned sensitivity range associated with that sensor code, as described above). Thereafter, the receiver/monitor unit **104/106** may be configured to use the sensor code in performing associated routines such as glucose rate of change verification, data

quality checks discussed above, and/or sensor sensitivity range acceptability or confirmation.

[0181] In a further aspect, the sensor codes may be associated with a coefficient of variation of the predetermined number of sampled sensors discussed above in addition to using the mean value determined as discussed above. In one embodiment, the coefficient of variation may be determined from the predetermined number of sampled sensors during the manufacturing process. In addition, the mean response time of the sampled sensors may be used by separately measuring the predetermined number of sampled sensors which may be used for lag correction adjustments and the like.

[0182] In this manner, in one aspect, the manufacturing process control described above ensures that the coefficient of variation of the sampled sensors is within a threshold value. That is, the value of the nominal sensitivity is used to determine a sensor code, selected or looked up from a predetermined table, and that is assigned to the sensors from the respective sensor lot in manufacturing. The user then enters the sensor code into the receiver/monitor unit that uses the sensor code to determine the glucose rate of change for purposes of data quality checking, for example, and also to determine validity or reasonableness of the sensitivity that is determined.

[0183] In one embodiment, a method may comprise sampling a predetermined number of in vivo analyte sensors, determining a sensitivity value for each of the sampled predetermined number of analyte sensors, and determining a mean sensitivity based on the sensitivity value of the predetermined number of analyte sensors.

[0184] The predetermined number of analyte sensors may be approximately 100 or less.

[0185] The sensitivity value may be determined in vitro.

[0186] The in vitro determination of the sensitivity value may include measuring the sensitivity value for each analyte sensor.

[0187] Measuring the sensitivity value for each analyte sensor may be performed during sensor manufacturing.

[0188] One aspect may include determining a sensor code associated with a predetermined sensitivity range.

[0189] The mean sensitivity may be within the predetermined sensitivity range.

[0190] The sensor code may be used to calibrate the analyte sensors.

[0191] The sensor code may be stored in an analyte monitoring device.

[0192] One aspect may include determining a deviation of the sensitivity value to a predetermined level.

[0193] One aspect may include when the determined deviation exceeds a tolerance threshold level, rejecting the predetermined number of analyte sensors during manufacturing.

[0194] In one embodiment a method may comprise, receiving a sensor code, retrieving a sensitivity associated with the sensor code corresponding to an analyte sensor, and performing data processing based at least in part on the sensor code.

[0195] The sensor code may be associated with a predetermined sensitivity range.

[0196] The sensitivity may be within the predetermined sensitivity range.

[0197] One aspect may include storing the sensor code.

[0198] One aspect may include performing data processing which may include one or more of a glucose rate verification routine, a data integrity verification routine, or a predetermined sensitivity range validity verification.

[0199] In one embodiment an apparatus may comprise a data processing unit configured to receive an analyte sensor code, retrieve a sensitivity associated with the sensor code corresponding to an analyte sensor, and perform data processing based at least in part on the sensor code.

[0200] The sensor code may be associated with a predetermined sensitivity range.

[0201] The sensitivity may be within the predetermined sensitivity range.

[0202] The data processing unit may be configured to perform one or more of a glucose rate verification routine, a data integrity verification routine, or a predetermined sensitivity range validity verification.

[0203] One aspect may include a data storage unit for storing one or more of the sensor code or the sensitivity.

[0204] The data processing unit may be configured to determine a coefficient of variation based on a sampled predetermined number of analyte sensors.

[0205] The sampled predetermined number of analyte sensors may include a subset of each sensor lot during manufacturing.

[0206] Various other modifications and alterations in the structure and method of operation of this invention will be apparent to those skilled in the art without departing from the scope and spirit of the invention. Although the invention has been described in connection with specific preferred embodiments, it should be understood that the invention as claimed should not be unduly limited to such specific embodiments. It is intended that the following claims define the scope of the present disclosure and that structures and methods within the scope of these claims and their equivalents be covered thereby.

What is claimed is:

1. A method, comprising:

determining a sensitivity value for one or more sensors of a batch of in vivo analyte sensors;

determining a sensitivity variation for the one or more sensors of the batch of in vivo analyte sensors;

determining a batch sensitivity for the batch of in vivo analyte sensors when it is determined that each of the determined sensitivity variations do not exceed a threshold level, by at least discarding some of the determined sensitivity values for the one or more sensors of the batch of in vivo analyte sensors;

associating a sensor code with the one or more sensors of the batch of in vivo analyte sensors, wherein the sensor code associated with each particular sensor of the one or more sensors of the batch of in vivo analyte sensors is at least partially based on a characteristic specific to the particular sensor; and

storing the sensor code associated with at least one sensor of the one or more sensors of the batch of in vivo analyte sensors in a memory of a data processing device associated with the sensor.

* * * * *