



US 20240119904A1

(19) **United States**

(12) **Patent Application Publication**
KIM et al.

(10) **Pub. No.: US 2024/0119904 A1**

(43) **Pub. Date: Apr. 11, 2024**

(54) **DISPLAY DEVICE**

Publication Classification

(71) Applicant: **Samsung Display Co., Ltd.**, Yongin-si (KR)

(51) **Int. Cl.**
G09G 3/3258 (2006.01)
G09G 3/00 (2006.01)

(72) Inventors: **Kwang-Min KIM**, Seoul (KR);
Seung-Kyu LEE, Asan-si (KR); **Won Kyu KWAK**, Seongnam-si (KR)

(52) **U.S. Cl.**
CPC **G09G 3/3258** (2013.01); **G09G 3/006** (2013.01); **G09G 3/3266** (2013.01)

(21) Appl. No.: **18/545,728**

(57) **ABSTRACT**

(22) Filed: **Dec. 19, 2023**

Related U.S. Application Data

(63) Continuation of application No. 18/103,145, filed on Jan. 30, 2023, now Pat. No. 11,893,941, which is a continuation of application No. 17/827,520, filed on May 27, 2022, now Pat. No. 11,568,818, which is a continuation of application No. 16/896,138, filed on Jun. 8, 2020, now Pat. No. 11,348,527, which is a continuation of application No. 16/111,831, filed on Aug. 24, 2018, now Pat. No. 10,679,561.

A display device is provided. The display device may include a substrate, a plurality of pixels, a first data line, a second data line, a defect sensing line, a first input pad, and a static electricity discharge element. The substrate may include a display area and a peripheral area neighboring each other. The plurality of pixels may be positioned on the display area and may include a first pixel and a second pixel. The first data line may be electrically connected to the first pixel. The second data line may be electrically connected to the second pixel and may be electrically isolated from the first data line. The defect sensing line may be positioned on the peripheral area. The first input pad may be electrically connected to the defect sensing line. The static electricity discharge element may be electrically connected through the defect sensing line to the first input pad.

Foreign Application Priority Data

Aug. 24, 2017 (KR) 10-2017-0107248

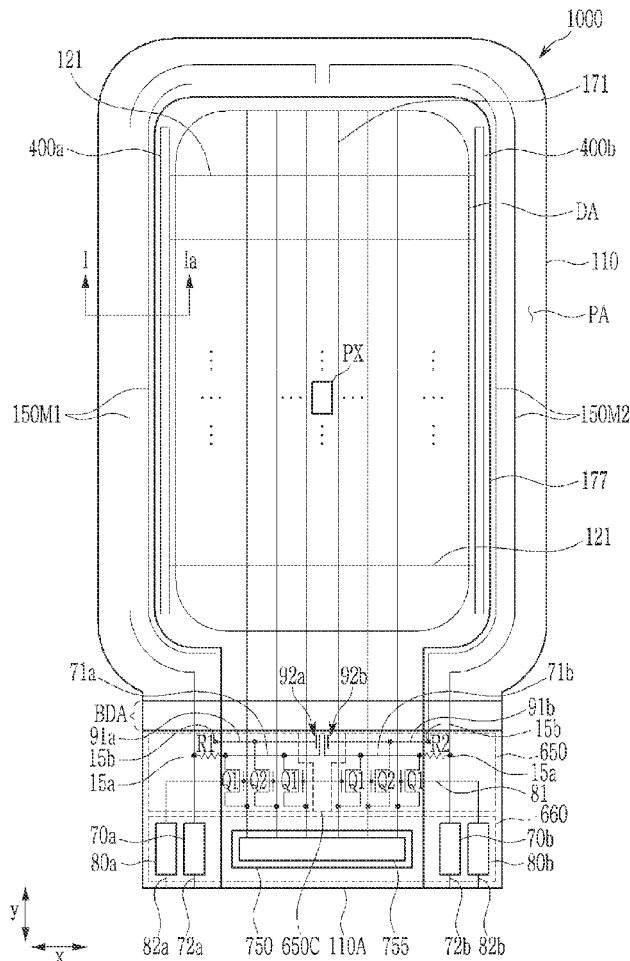

FIG. 1

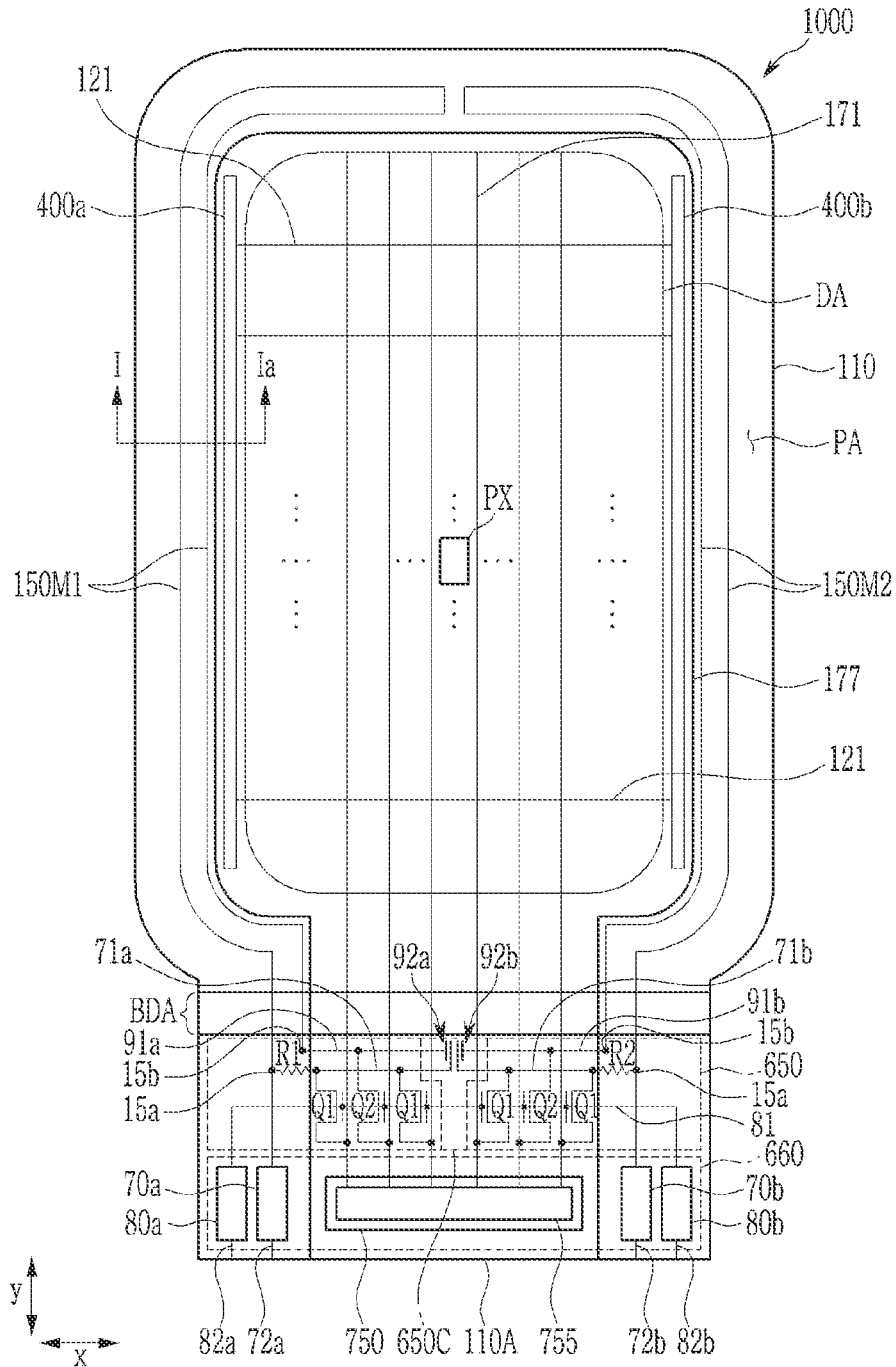

FIG. 2

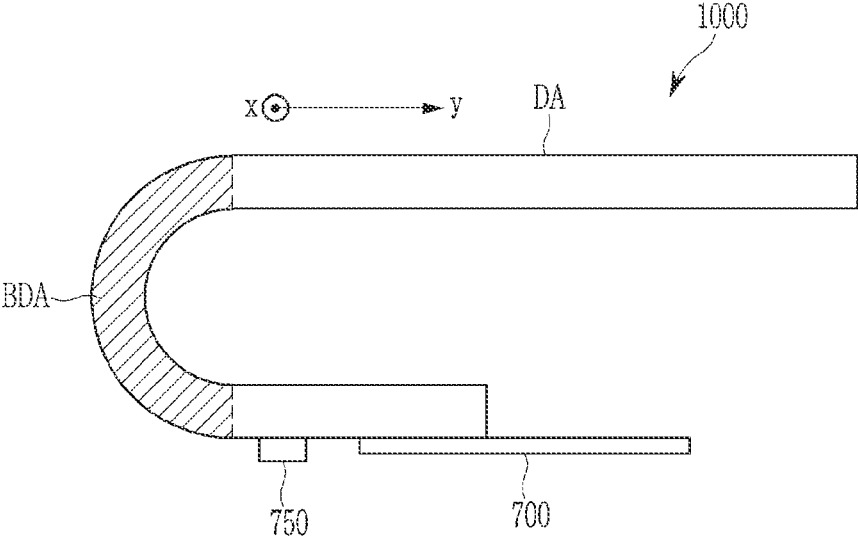

FIG. 3

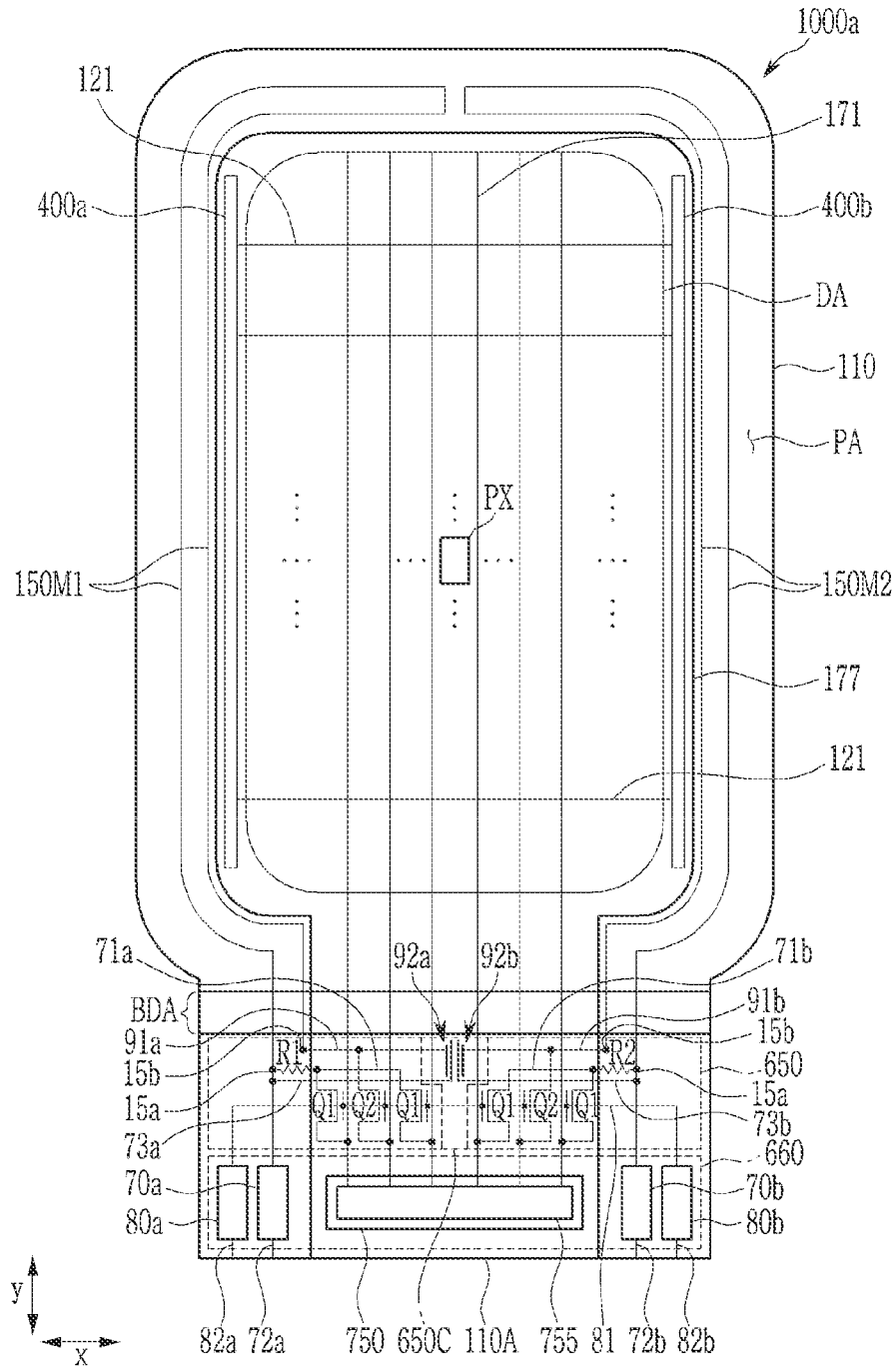

FIG. 4

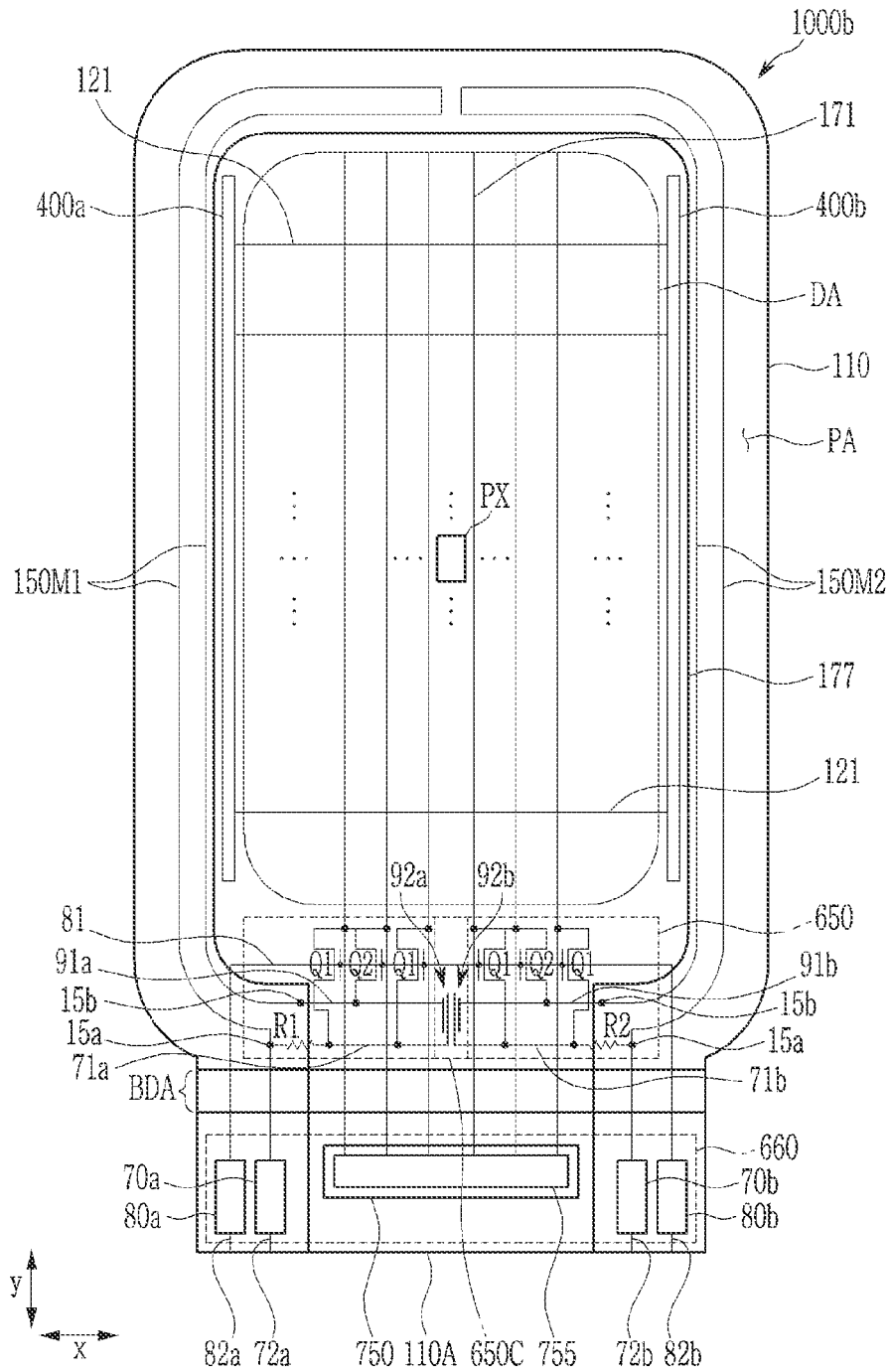

FIG. 5

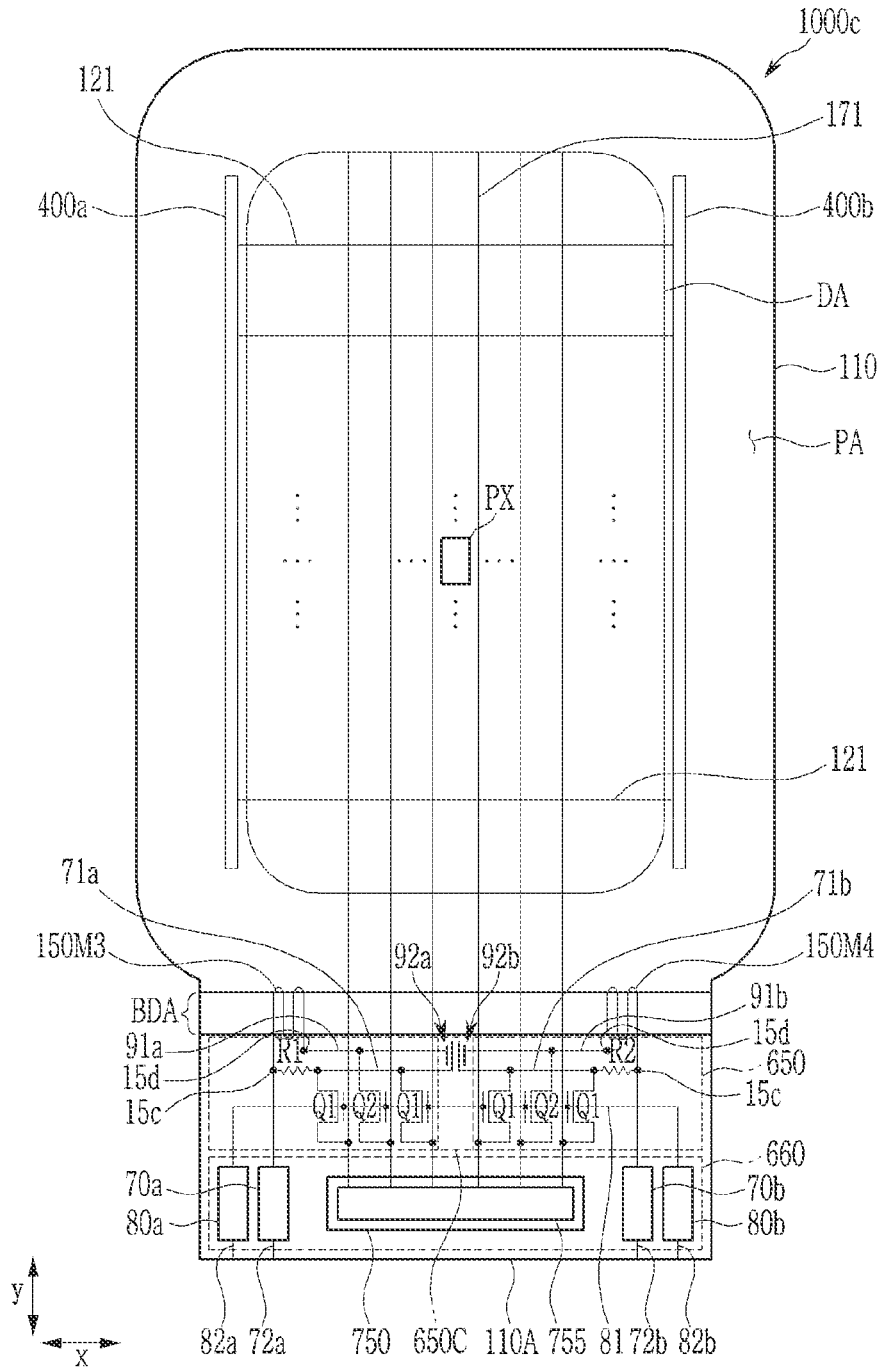

FIG. 6

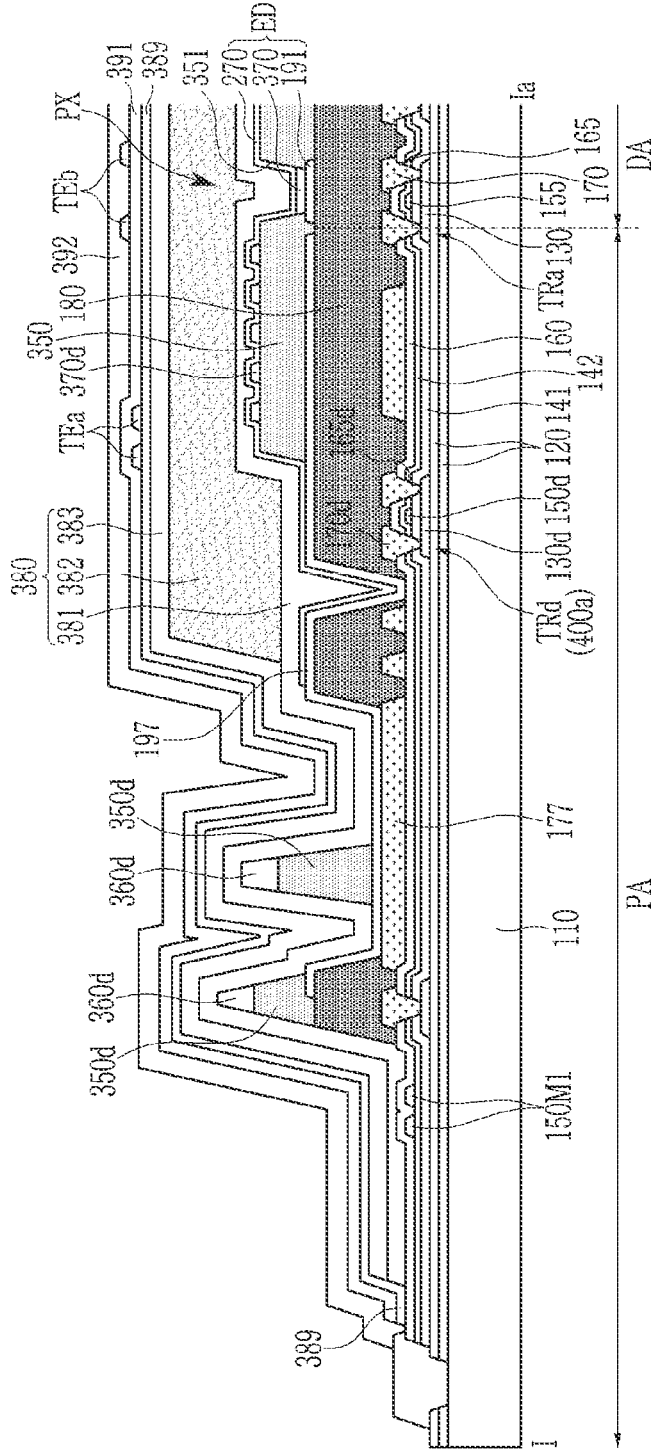

FIG. 7

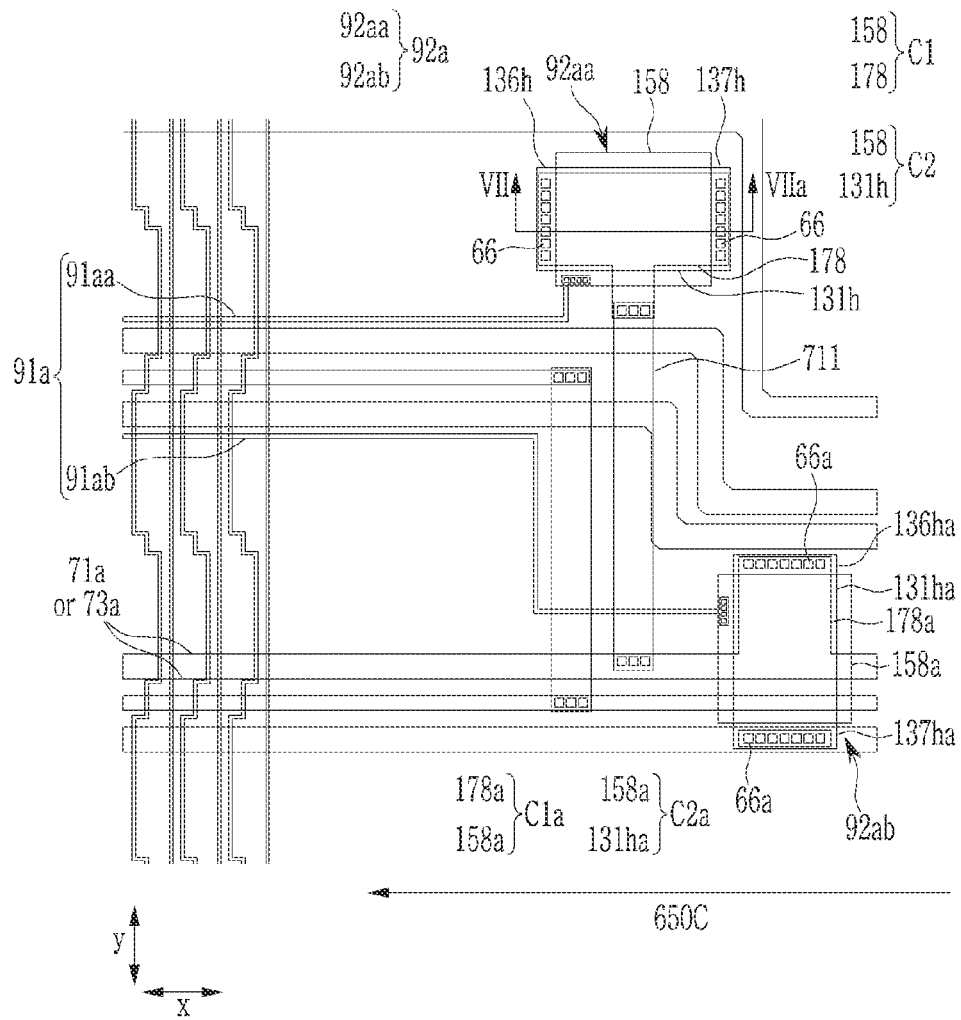

FIG. 8

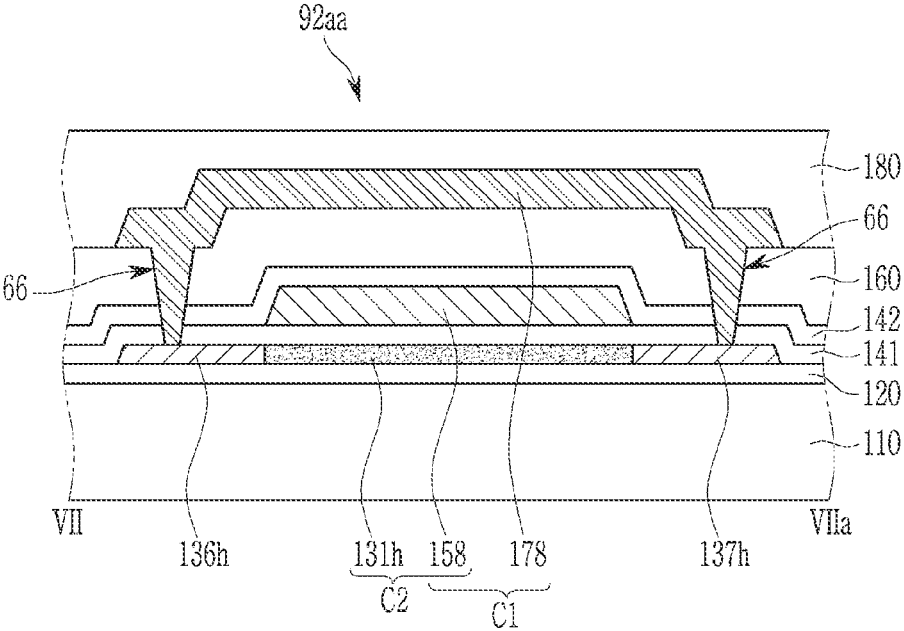
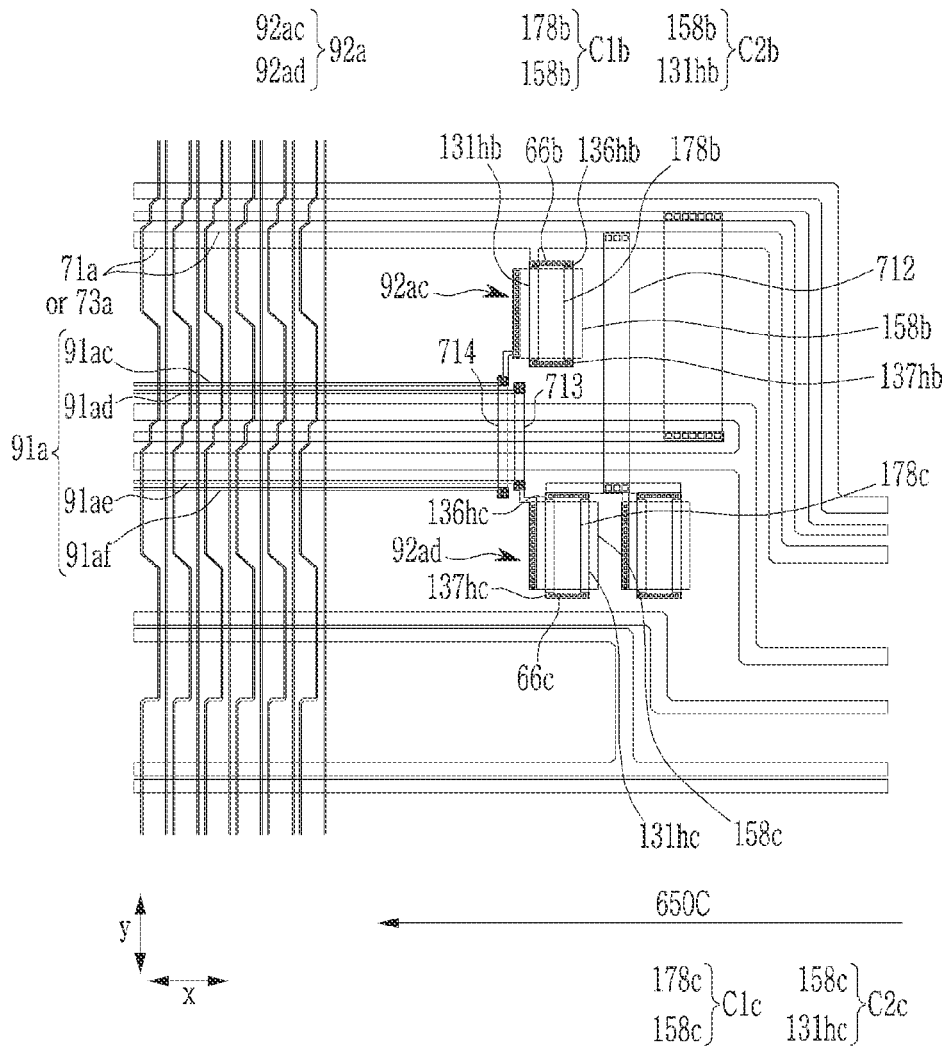

FIG. 9



DISPLAY DEVICE**CROSS-REFERENCE TO RELATED APPLICATIONS**

[0001] This application is a continuation application of U.S. patent application Ser. No. 18/103,145 filed on Jan. 30, 2023, which is a continuation application of U.S. patent application Ser. No. 17/827,520 filed on May 27, 2022 (now U.S. Pat. No. 11,568,818), which is a continuation application of U.S. patent application Ser. No. 16/896,138 filed on Jun. 8, 2020 (now U.S. Pat. No. 11,348,527), which is a continuation application of U.S. patent application Ser. No. 16/111,831 filed on Aug. 24, 2018 (U.S. Pat. No. 10,679,561), which claims priority to Korean Patent Application No. 10-2017-0107248 filed in the Korean Intellectual Property Office on Aug. 24, 2017, the entire contents of which are incorporated herein by reference.

BACKGROUND

(a) Technical Field

[0002] The technical field relates to a display device.

(b) Description of the Related Art

[0003] A display device, such as a liquid crystal display (LCD) or an organic light emitting diode (OLED) display, may include a display panel that includes a plurality of pixels and a plurality of signal lines. Each pixel may include a pixel electrode connected through a transistor to a signal line for receiving a data signal. The display panel may include a plurality of stacked layers, including a substrate.

[0004] In the manufacturing process of the display panel, when the display panel receives an impact, cracks may occur in the substrate and/or other layers. The cracks may grow larger and/or spread in the display panel over time, causing significant defects. For example, if a crack is generated in a signal line (such as a data line or a scanning line), the signal line may be disconnected, or the resistance of the signal line may increase, such that signals cannot be properly transmitted. Moisture etc. may penetrate into the display panel through cracks, such that the reliability of the display device may be reduced. As a result, the display device may malfunction.

[0005] The above information disclosed in this Background section is for enhancement of understanding of the relevant background. The Background section may contain information that does not form the prior art that is already known in this country to a person of ordinary skill in the art.

SUMMARY

[0006] An embodiment may protect a defect-detecting circuit and/or a defect-detecting electrical element in a display panel from static electricity. An embodiment may optimize accuracy of defect detection during testing of the display panel.

[0007] A display device according to an embodiment may comprise the following elements: a substrate comprising a display area comprising a plurality of pixels, a pad area comprising a plurality of input pads, and a circuit area positioned between the pad area and the display area and comprising a crack sensing circuit; a crack sensing line comprising a part positioned around the display area and two ends, wherein the two ends comprise a first end connected

to a first input pad among the plurality of input pads and a second end; and a plurality of data lines connected to the plurality of pixels, wherein the crack sensing circuit comprises a static electricity discharge element connected to the second end.

[0008] The circuit area may comprise a center area positioned at a center thereof, and the static electricity discharge element may be positioned at the center area.

[0009] The circuit area may comprise a first switching element comprising an input terminal connected to the first end and an output terminal connected to a first data line among the plurality of data lines, and a second switching element comprising an input terminal connected to the second end and an output terminal connected to a second data line among the plurality of data lines, and the first and second switching elements may not be positioned at the center area.

[0010] A first test data line connecting the first end and the first switching element to each other, and a second test data line connecting the second end and the second switching element to each other, may be further comprised.

[0011] The static electricity discharge element may be connected to the first test data line and the second test data line.

[0012] The static electricity discharge element may comprise a capacitor comprising a third end connected to the first test data line, and a fourth end connected to the second test data line as two terminals.

[0013] The second test data line may comprise a plurality of sub-wires, and the capacitor may comprise a plurality of sub-capacitors respectively connected to a corresponding sub-wire of the plurality of sub-wires.

[0014] A connection wire connected to the first end and extending approximately parallel to the first test data line may be further comprised, and the static electricity discharge element may be connected to the connection wire and the second test data line.

[0015] The static electricity discharge element may comprise a capacitor comprising a third end connected to the connection wire and a fourth end connected to the second test data line as two terminals.

[0016] The second test data line may comprise a plurality of sub-wires, and the capacitor may comprise a plurality of sub-capacitors respectively connected to a corresponding sub-wire of the plurality of sub-wires.

[0017] The substrate may further comprise a bending area positioned between the display area and the circuit area, the crack sensing line may comprise a part positioned at the bending area, a voltage transmitting line having a part extending along a circumference of the display area and a part crossing the bending area may be further comprised, and the voltage transmitting line and the crack sensing line may be positioned at a same layer as each other in the bending area.

[0018] A display device according to an embodiment may comprise the following elements: a substrate comprising a display area comprising a plurality of pixels, a pad area comprising a plurality of input pads, and a circuit area positioned between the pad area and the display area and comprising a crack sensing circuit; a crack sensing line comprising a part positioned around the display area and two ends, wherein the two ends comprise a first end connected to a first input pad among the plurality of input pads and a second end; and a plurality of data lines connected to the

plurality of pixels, wherein the crack sensing circuit comprises at least one capacitor comprising a third end connected to the first input pad and a fourth end connected to the second end as two terminals.

[0019] The circuit area may comprise a center area positioned at a center thereof, and the capacitor may be positioned at the center area.

[0020] The circuit area may comprise a first switching element having an input terminal connected to the first end and an output terminal connected to a first data line among the plurality of data lines, and a second switching element having an input terminal connected to the second end and an output terminal connected to a second data line among the plurality of data lines, and the first and second switching elements may not be positioned at the center area.

[0021] A first test data line connecting the first end and the first switching element to each other and a second test data line connecting the second end and the second switching element to each other may be further comprised, the third end may be connected to the first test data line, and the fourth end may be connected to the second test data line.

[0022] A first test data line connecting the first end and the first switching element to each other, a second test data line connecting the second end and the second switching element to each other, and a connection wire connected to the first end and extending approximately parallel to the first test data line may be further comprised, the third end may be connected to the connection wire, and the fourth end is connected to the second test data line.

[0023] An embodiment may be related to a display device. The display device may include a substrate, a plurality of pixels, a first data line, a second data line, a defect sensing line, a first input pad, and a static electricity discharge element. The substrate may include a display area and a peripheral area neighboring each other. The plurality of pixels may be positioned on the display area and may include a first pixel and a second pixel. The first data line may be electrically connected to the first pixel. The second data line may be electrically connected to the second pixel and may be electrically isolated from the first data line. The defect sensing line may be positioned on the peripheral area. The first input pad may be electrically connected to the defect sensing line. The static electricity discharge element may be electrically connected through the defect sensing line to the first input pad.

[0024] An edge of the display area may be positioned between the defect sensing line and the static electricity discharge element.

[0025] The display device may include a first switching element and a second switching element. An input terminal of the first switching element may be electrically connected to the defect sensing line. An output terminal of the first switching element may be electrically connected to the first data line. An input terminal of the second switching element may be electrically connected through the defect sensing line to the input terminal of the first switching element. An output terminal of the second switching element may be electrically connected to the second data line.

[0026] The display device may include the following elements: a first test data line electrically connecting the defect sensing line and the first switching element to each other; and a second test data line electrically connecting the defect sensing line and the second switching element to each other.

[0027] The static electricity discharge element may be electrically connected between the first test data line and the second test data line.

[0028] The static electricity discharge element may include a capacitor. A first terminal of the capacitor may be electrically connected to the first test data line. A second terminal of the capacitor may be electrically connected to the second test data line.

[0029] The second test data line may include a plurality of sub-wires. The capacitor may include a plurality of sub-capacitors. The sub-capacitors may be respectively electrically connected to a corresponding sub-wire of the sub-wires.

[0030] The display device may include a connection wire electrically connected to the defect sensing line and extending parallel to the first test data line. The static electricity discharge element may be electrically connected through the connection wire to the first test data line.

[0031] The static electricity discharge element may include a capacitor. A first terminal of the capacitor may be electrically connected to the connection wire. A second terminal of the capacitor may be electrically connected to the second test data line.

[0032] The second test data line may include a plurality of sub-wires. The capacitor may include a plurality of sub-capacitors. The sub-capacitors may be respectively electrically connected to a corresponding sub-wire of the sub-wires.

[0033] The display device may include the following elements: a voltage transmitting line positioned between the defect sensing line and the plurality of pixels; and an insulating layer positioned on the substrate. The substrate may further include a bent portion bent relative to the display area. A portion of the insulating layer may be positioned on the bent portion. A section of the defect sensing line may be positioned on the bent portion and may directly contact the portion of the insulating layer. A section of the voltage transmitting line may be positioned on the bent portion and may directly contact the portion of the insulating layer.

[0034] The static electricity discharge element may include a capacitor. A first terminal of the capacitor may be electrically connected through the defect sensing line to the first input pad.

[0035] The first terminal of the capacitor may be electrically connected to the first input pad through both a first section of the defect sensing line and a second section of the defect sensing line. The first section of the defect sensing line and the second section of the defect sensing line may extend parallel to each other.

[0036] The display device may include a first switching element positioned between the defect sensing line and the static electricity discharge element. An input terminal of the first switching element may be electrically connected to the defect sensing line. An output terminal of the first switching element may be electrically connected to the first data line.

[0037] The display device may include the following elements: a second switching element. An input terminal of the second switching element may be electrically connected to the defect sensing line. An output terminal of the second switching element may be electrically connected to the second data line. The static electricity discharge element may be positioned between the first switching element and the second switching element.

[0038] The substrate may further include a bent portion bent relative to the display area. A first section of the defect sensing line may be positioned on the bent portion. The static electricity discharge element may be electrically connected through the first section of the defect sensing line to the first input pad.

[0039] A second section of the defect sensing line may be spaced from the first section of the defect sensing line and may be positioned on the bent portion. The static electricity discharge element may be electrically connected through both the first section of the defect sensing line and the second section of the defect sensing line to the first input pad.

[0040] The static electricity discharge element may be positioned between the bent portion and the first switching element.

[0041] The first data line and the second data line immediately neighbor each other with no intervening data line. The static electricity discharge element may be electrically connected between the first data line and the second data line.

[0042] The display device may further include: a test data line intersecting the first data line and electrically connecting the static electricity discharge element to the defect sensing line.

[0043] According to embodiments, the circuit and/or electrical elements for detecting defects, such as cracks, generated in a display panel may be protected from static electricity, and the accuracy of defect detection may be optimized during testing of the display panel.

BRIEF DESCRIPTION OF THE DRAWINGS

[0044] FIG. 1 is a top plan view of a display panel included in a display device according to an embodiment.

[0045] FIG. 2 is a side view showing a display panel that has a bent portion according to an embodiment.

[0046] FIG. 3 is a top plan view of a display panel included in a display device according to an embodiment.

[0047] FIG. 4 is a top plan view of a display panel included in a display device according to an embodiment.

[0048] FIG. 5 is a top plan view of a display panel included in a display device according to an embodiment.

[0049] FIG. 6 is a cross-sectional view of a display device taken along a line I-Ia shown in FIG. 1 according to an embodiment.

[0050] FIG. 7 is a layout view of a part of a circuit area of a display panel according to an embodiment.

[0051] FIG. 8 is a cross-sectional view of a display panel taken along a line VII-VIIa shown in FIG. 7 according to an embodiment.

[0052] FIG. 9 is a layout view of a part of a circuit area of a display panel according to an embodiment.

DETAILED DESCRIPTION

[0053] Example embodiments are described with reference to the accompanying drawings. As those skilled in the art would realize, the described embodiments may be modified in various different ways.

[0054] Although the terms “first,” “second,” etc. may be used herein to describe various elements, these elements, should not be limited by these terms. These terms may be used to distinguish one element from another element. Thus, a first element may be termed a second element without

departing from teachings of one or more embodiments. The description of an element as a “first” element may not require or imply the presence of a second element or other elements. The terms “first,” “second,” etc. may also be used herein to differentiate different categories or sets of elements. For conciseness, the terms “first,” “second,” etc. may represent “first-type (or first-set),” “second-type (or second-set),” etc., respectively.

[0055] In the drawings, for better understanding and ease of description, the thicknesses of some elements may be exaggerated.

[0056] When a first element is referred to as being “on” a second element, the first element can be directly on the second element, or one or more intervening elements may be present between the first element and the second element. When a first element is referred to as being “directly on” a second element, there are no intended intervening elements (except environmental elements such as air) present between the first element and the second element. The word “on” or “above” may mean positioned on or below the object portion, and does not necessarily mean positioned on the upper side of the relative object based on a gravitational direction.

[0057] Unless explicitly described to the contrary, the word “comprise” and variations such as “comprises” or “comprising” may imply the inclusion of stated elements but not the exclusion of other elements. The term “connect” may mean “electrically connect”; the term “insulate” may mean “electrically insulate.”

[0058] FIG. 1 is a top plan view of a display panel included in a display device according to an embodiment. FIG. 2 is a side view showing a display panel that has a bent portion according to an embodiment.

[0059] Referring to FIG. 1 and FIG. 2, a display device according to an embodiment may include a display panel **1000** having a display area DA as an area for displaying an image and a peripheral area PA neighboring, abutting, and/or surrounding the display area DA. The display panel **1000** includes a substrate **110**. The substrate **110** may include a display area and a peripheral area respectively corresponding to the display area DA and peripheral area PA of the display panel **1000**.

[0060] The substrate **110** may include at least one of glass, plastic, etc., and may have flexibility. For example, the substrate **110** may be formed of a plastic material (such as PET, PEN, PC, PAR, PEI, PES, or PI), a metal thin film, or a thin film glass.

[0061] The display area DA may display the image on a surface parallel to a plane defined by an x direction and a y direction. A structure observed when viewing in a direction perpendicular to the x direction and the y direction may be referred to as a plane structure, and a structure observed when cut along a direction perpendicular to the x direction or the y direction may be referred to as a cross-sectional structure.

[0062] The display area DA includes a plurality of pixels PX and a plurality of signal lines.

[0063] The signal lines include a plurality of gate lines **121** for transmitting gate signals and a plurality of data lines **171** for transmitting data signals. Each gate line **121** substantially extends in the x direction in the display area DA, and may be connected to gate drivers **400a** and **400b** outside the

display area DA. Each data line **171** substantially extends in the y direction in the display area DA, and also extends outside the display area DA.

[0064] A pixel PX may include a switching element and a pixel electrode connected to the switching element. The switching element may be a three-terminal element such as a transistor integrated on the display panel **1000**. The switching element is turned on or turned off depending on the gate signal transmitted by the gate line **121**, for controlling transmission of a data signal to the pixel electrode.

[0065] In order to implement a color display, each pixel PX may display one of predetermined colors, and an image of a desired color may be recognized by combining images displayed by the predetermined colors. An example of the predetermined colors displayed by the plurality of pixels PX may be three primary colors of red, green, and blue, or three primary colors of yellow, cyan, and magenta, and at least one different color such as white may be further included as well as the three primary colors.

[0066] In addition to the display area DA, as shown in FIG. 1, the display panel **1000** may include the peripheral area PA, a bending area BDA (which may be bent relative to the display area DA), a circuit area **650**, a pad area **660**, etc.

[0067] The peripheral area PA positioned around the display area DA may be an area adjacent to the display area DA and enclosing the display area DA. The bending area BDA may be positioned under a lower side of the display area DA, and may extend across the display panel **1000** in the x direction. The pad area **660** is positioned outside the bending area BDA, thereby being positioned to be adjacent to the display panel **1000** or a lower edge **110A** of the substrate **110**. That is, the bending area BDA may be positioned between the display area DA and the pad area **660**. The circuit area **650** includes a plurality of electrical elements such as the transistor and may be positioned under the lower side of the display area DA. As shown in FIG. 1, the circuit area **650** may be positioned between the bending area BDA and the pad area **660**, or alternately, it may be positioned between the display area DA and the bending area BDA or at the peripheral area PA on an upper side of the display area DA.

[0068] The peripheral area PA may include the gate drivers **400a** and **400b**, voltage transmitting lines **177**, and crack sensing lines **150M1** and **150M2** (or defect sensing lines **150M1** and **150M2**).

[0069] The gate drivers **400a** and **400b** are connected to the plurality of gate lines **121**, for applying gate signals. The gate drivers **400a** and **400b** may be formed on the substrate **110** along with the plurality of signal lines and the switching element positioned on the display area DA. FIG. 1 shows an example in which the gate drivers **400a** and **400b** are positioned one by one on the right and left sides based on the display area DA. In an embodiment, either one of the gate drivers **400a** and **400b** may be unnecessary.

[0070] The voltage transmitting line **177** may extend along at least three sides such as the upper, right, and left sides of the display area DA, and may transmit a predetermined voltage such as a common voltage.

[0071] Each of the crack sensing lines **150M1** and **150M2** may have two ends including a first end **15a** and a second end **15b**, and may extend along the left side and a part of the upper side, or along the right side and a part of the upper side of the display area DA, between the first end **15a** and the second end **15b**. For example, the crack sensing line **150M1**

may include a part substantially extending in the y direction in the left peripheral area PA of the display area DA and a part substantially extending in the x direction in the upper peripheral area PA of the left half of the display area DA, and the crack sensing line **150M2** may include a part substantially extending in the y direction in the right peripheral area PA of the display area DA and a part substantially extending in the x direction in the upper peripheral area PA of the right half of the display area DA.

[0072] Each of the crack sensing lines **150M1** and **150M2** may start from the first end **15a** connected to the pad area **660**, extend along the circumference of the display area DA in the peripheral area PA through the bending area BDA, reciprocate at least once in the right/left or upper peripheral area PA of display area DA to form at least one bending part, and again pass the bending area BDA to be connected to the circuit area **650** at the second end **15b**. The first end **15a** of the crack sensing lines **150M1** and **150M2** is connected to the pad area **660**, thereby receiving a test voltage.

[0073] When a cross-sectional position of a conductive layer positioned at the bending area BDA and a cross-sectional position of the crack sensing lines **150M1** and **150M2** positioned at the peripheral area PA are not same, the crack sensing lines **150M1** and **150M2** may include at least one contact part positioned above and below the bending area BDA. The crack sensing lines **150M1** and **150M2** may include parts positioned on different layers in a cross-section with respect to the contact part. The contact part may include at least one contact hole. In the bending area BDA, the voltage transmitting line **177** and the crack sensing lines **150M1** and **150M2** may all directly contact (the same surface/side of) the third insulating layer **160** shown in FIG. 6 and/or (a same surface/side of) another insulating layer.

[0074] In an embodiment, differently from FIG. 1, the left and right crack sensing lines **150M1** and **150M2** may be connected to each other on the display area DA. The connection relationship of the circuit area **650** and/or the pad area **660** and the crack sensing lines **150M1** and **150M2** may be different from the structure shown in FIG. 1.

[0075] In a plan view, in the peripheral area PA positioned at the right/left sides of the display area DA, the gate drivers **400a** and **400b** may be positioned between the edge of the display area DA and the voltage transmitting line **177**, the voltage transmitting line **177** may be positioned between the gate drivers **400a** and **400b** and the crack sensing lines **150M1** and **150M2**, and the crack sensing lines **150M1** and **150M2** may be positioned between the voltage transmitting line **177** and the edge of the substrate **110**. However, the arrangement of these constituent elements may be changed in other ways.

[0076] The display panel **1000** is bent in the bending area BDA such that elements positioned in the circuit area **650** and/or the pad area **660** may be hidden behind the display panel **1000** and may not be seen from the front of the display device. FIG. 1 shows the state that the display panel **1000** is not significantly bent in the bending area BDA, and FIG. 2 schematically shows the state that the display panel **1000** is bent in the bending area BDA. A plurality of wires may pass the bending area BDA, and the plurality of wires may substantially extend in the y direction in the bending area BDA. At least part of the substrate **110** may be removed in the bending area BDA.

[0077] The bending area BDA may be unnecessary depending on the structure of the display device.

[0078] Referring to FIG. 1 and FIG. 2, the pad area 660 may include a plurality of pads that may be electrically connected to a pad of a driving chip 750 and/or a pad of a circuit film 700. According to an embodiment, the driving chip 750 and/or the circuit film 700 may be electrically connected to the display panel 1000 through the pad area 660.

[0079] As shown in FIG. 2, the driving chip 750 may be positioned on the display panel 1000 or on the circuit film 700. The driving chip 750 may include a driver generating a driving signal to drive the display panel 1000.

[0080] The circuit film 700 may be a film type. Referring to FIG. 2, the circuit film 700 may be connected to the area outside the bending area BDA when bending the display panel 1000. The driver, a timing controller, etc. may be positioned in the circuit film 700.

[0081] A plurality of pads included in the pad area 660 may include input pads 70a and 70b and input pads 80a and 80b.

[0082] The circuit area 650 is connected to the crack sensing lines 150M1 and 150M2, and includes a crack sensing circuit (or defect sensing circuit) capable of sensing defects (such as cracks or protrusions) that occur in the substrate 110 or the layers deposited on the substrate 110 at the peripheral area PA, based on a resistance change of at least one of the crack sensing lines 150M1 and 150M2. The resistance change of the crack sensing lines 150M1 and 150M2 may be confirmed by testing a lighting state of the display area DA through the crack sensing circuit.

[0083] The first ends 15a of the crack sensing lines 150M1 and 150M2 may be connected to input pads 70a and 70b of the pad area 660, and the second ends 15b of the crack sensing lines 150M1 and 150M2 may be connected to test data lines 91a and 91b. The first ends 15a of the crack sensing lines 150M1 and 150M2 connected to the input pads 70a and 70b may be connected to test data lines 71a and 71b.

[0084] Two test data lines 91a and 91b may be separated and electrically isolated from each other, and two test data lines 71a and 71b may also be separated and electrically isolated from each other. Each of the test data lines 71a, 71b, 91a, and 91b may substantially extend in the x direction, and may cross the data lines 171 while being insulated from the data lines 171.

[0085] The crack sensing circuit of the circuit area 650 may further include a test gate line 81 and a plurality of switching elements Q1 and Q2 connected to the test gate line 81.

[0086] The test gate line 81 is connected to the input pads 80a and 80b and may extend substantially in the x direction in the circuit area 650. The test gate line 81 may receive the gate signal for the test through the input pads 80a and 80b.

[0087] The plurality of switching elements Q1 and Q2 may be arranged in one row or a plurality of rows substantially extending in the x direction, and may be disposed corresponding to the part of the plurality of data lines 171. FIG. 1 shows an example in which the plurality of switching elements Q1 and Q2 are arranged in one row. The switching elements Q1 and Q2 may be alternately arranged in the x direction, and each of the switching elements Q1 and Q2 may be disposed one by one for each data line 171. The switching element Q2 may be disposed at the partial area of the circuit area 650, for example, a right partial area and a left partial area of the circuit area 650, and the switching element Q1 may be disposed at the remaining area. FIG. 1

shows an example in which one switching element Q2 is positioned at both the left side and the right side of the circuit area 650, but alternatively, a plurality of switching elements Q2 may be positioned to be adjacent to the switching elements Q1 in the x direction at the right side and the left side of the circuit area 650. Also, the arrangement of the switching elements Q1 and Q2 may be variously changed.

[0088] A gate terminal of each of the switching elements Q1 and Q2 is connected to the test gate line 81 and an output terminal thereof is connected to the corresponding data line 171. An input terminal of the switching element Q1 is connected to the test data lines 71a and 71b, and the input terminal of the switching element Q2 is connected to the test data lines 91a and 91b.

[0089] Referring to FIG. 1, the test data lines 71a and 71b between the input pads 70a and 70b and the switching element Q1 may include matching resistors R1 and R2. The test voltage applied through the input pads 70a and 70b may be applied to the input terminal of the switching element Q1 after being decreased by a first voltage difference via the matching resistors R1 and R2. On the other hand, the test voltage applied through the input pads 70a and 70b may be transmitted to the crack sensing lines 150M1 and 150M2, and the voltage that is decreased by a second voltage difference by a wire resistance of the crack sensing lines 150M1 and 150M2 may be applied to the input terminal of the switching element Q2 through the test data lines 91a and 91b. The resistance of each of the matching resistors R1 and R2 may be equal or close to the wire resistance of each of the crack sensing lines 150M1 and 150M2. Also, the resistance of the matching resistors R1 and R2 may be determined so that the first voltage difference and the second voltage difference are substantially equal or equivalent to each other in the case that there is no the damage such as the crack or the lifting in the crack sensing lines 150M1 and 150M2 as a normal state. In an embodiment, the resistance of the matching resistors R1 and R2 may be determined based on crack detection sensitivity. For example, the resistance of each of the matching resistors R1 and R2 may be determined to be approximately 1.5 times the wire resistance of each of the crack sensing lines 150M1 and 150M2.

[0090] The data line 171 may also extend below the circuit area 650 and may be connected to a lighting circuit 755 for testing the defect of the display area DA. The lighting circuit 755 may include the electrical element such as a plurality of transistors, etc. The lighting circuit 755 may be positioned below or above the display area DA. FIG. 1 shows an example in which the lighting circuit 755 is positioned at the pad area 660, particularly the area where the driving chip 750 is positioned.

[0091] Referring to FIG. 1, the display panel 1000 further includes static electricity discharge elements 92a and 92b respectively connected to the second ends 15b of the crack sensing lines 150M1 and 150M2. The static electricity discharge elements 92a and 92b may be connected to the wire connected to the second ends 15b of the crack sensing lines 150M1 and 150M2, for example, the test data lines 91a and 91b. The static electricity discharge elements 92a and 92b may each be/include a capacitor, a transistor, or a diode. The static electricity discharge elements 92a and 92b may each be/include an electrical element capable of storing or discharging static electricity flowing into one of the second ends 15b of the crack sensing lines 150M1 and 150M2. In

an embodiment, each of the static electricity discharge elements **92a** and **92b** is the capacitor.

[0092] When each of the static electricity discharge elements **92a** and **92b** is a capacitor, one end/terminal of the capacitor may be connected to one of the test data lines **91a** and **91b**, and the other end/terminal may be connected to the wire connected to one of the input pads **70a** and **70b**, for example, one of the test data lines **71a** and **71b**. In an embodiment, each of the static electricity discharge elements **92a** and **92b** may be connected to the wire (e.g., one of the test data lines **91a** and **91b**) connected to the second end **15b** of one of the crack sensing lines **150M1** and **150M2** and the wire (e.g., one of the test data lines **71a** and **71b**) connected to one of the input pads **70a** and **70b**. An output terminal of each of the switching elements **Q1** and **Q2** is connected to the corresponding data line **171**, an input terminal of the switching element **Q1** is connected to one of the test data lines **71a** and **71b**, and the input terminal of the switching element **Q2** is connected to one of the test data lines **91a** and **91b**, and therefore, each of the static electricity discharge elements **92a** and **92b** may be electrically connected at between the data line **171** connected to the output terminal of the switching elements **Q1** and the data line **171** connected to the output terminal of the switching elements **Q2**.

[0093] The static electricity discharge elements **92a** and **92b** may be positioned at a center area **650C** that is substantially positioned at the center among the circuit area **650**. According to an embodiment, as the plurality of switching elements **Q1** and **Q2** are positioned at the right/left sides of the circuit area **650** and the empty space where the switching elements **Q1** and **Q2** are not disposed is formed in the center area **650C**, the static electricity discharge elements **92a** and **92b** may be positioned in this space. Accordingly, each of the test data lines **91a** and **91b** may extend to the center area **650C** and each of the test data lines **71a** and **71b** may also extend to the center area **650C**.

[0094] If there is no static electricity discharge elements **92a** and **92b** connected to the second ends **15b** of the crack sensing lines **150M1** and **150M2**, the crack sensing lines **150M1** and **150M2** having relatively large resistance serve as an antenna such that a large potential difference between a first **15a** and a second end **15b** of each of the crack sensing lines **150M1** and **150M2** may be easily generated. In that case, the static electricity tends to accumulate in the second end **15b** of the crack sensing lines **150M1** and **150M2**, so that the crack sensing circuits connected to the crack sensing lines **150M1** and **150M2** may be vulnerable to the static electricity, and a leakage current maybe generated in the switching element **Q2** connected to the second ends **15b** of the crack sensing lines **150M1** and **150M2**. Thus, in a defect test step that is not a step for testing the defect such as the crack of the peripheral area **PA**, for example, in the defect test step of the display area **DA** using the lighting circuit **755**, the lighting state of the pixel **PX** connected to the data line **171** connected to the switching element **Q2** maybe erroneously displayed in the defect state. That is, even if there is no defect in the data line **171** connected to the switching element **Q2** or the pixel **PX** connected thereto, the pixel **PX** column connected to the corresponding data line **171** is displayed in a weak dark line such that a defect may be erroneously detected.

[0095] In the display panel **1000** according to an embodiment, the second ends **15b** of the crack sensing lines **150M1**

and **150M2** are connected to the static electricity discharge elements **92a** and **92b**, such that the static electricity may be stored or discharged. For example, the static electricity may be stored in the capacitor of the static electricity discharge elements **92a** and **92b**, or may be discharged to the input pads **70a** and **70b** through the wires connected to the other ends of the capacitors, for example, the test data lines **71a** and **71b**. Accordingly, the damage due to the static electricity of the switching element **Q2** of the crack sensing circuit may be prevented, and leakage current of the switching element **Q2** may be prevented. Advantageously, erroneous detection of defects may be prevented in a defect testing process.

[0096] Shorting wires **72a**, **72b**, **82a**, and **82b** may be connected to the input pads **70a**, **70b**, **80a**, and **80b**, respectively. The shorting wires **72a**, **72b**, **82a**, and **82b** may extend from the input pads **70a**, **70b**, **80a**, and **80b** to the display panel **1000** or the lower edge **110A** of the substrate **110**. The ends of the shorting wires **72a**, **72b**, **82a**, and **82b** ending at the lower edge **110A** may not be connected to another conductor but may be in a floating state. The shorting wires **72a**, **72b**, **82a**, and **82b** may be connected to a shorting bar positioned under the lower edge **110A** during the manufacturing process, thereby transmitting a predetermined voltage such as a ground voltage.

[0097] FIG. 3 is a top plan view of a display panel included in a display device according to an embodiment. A display panel **1000a** illustrated in FIG. 3 may include features and/or structures discussed with reference to FIG. 1 and FIG. 2. However, one end of the capacitor of each of the static electricity discharge elements **92a** and **92b** is connected to one of the test data lines **91a** and **91b**, and the other end of the capacitor of each of the static electricity discharge elements **92a** and **92b** is connected to one of the connection wires **73a** and **73b** as a separate wire from the test data lines **71a** and **71b**. The connection wires **73a** and **73b** may be connected to the input pads **70a** and **70b** and the first ends **15a** of the crack sensing lines **150M1** and **150M2**, and may extend to be substantially parallel to the x direction in the circuit area **650** and substantially parallel to the test data lines **71a** and **71b**.

[0098] FIG. 4 is a top plan view of a display panel included in a display device according to an embodiment. A display panel **1000b** illustrated in FIG. 4 may include structures and/or features discussed with reference to one of more of FIG. 1, FIG. 2, and FIG. 3. However, the circuit area **650** in which the crack sensing circuit is positioned may be positioned between the display area **DA** and the bending area **BDA**.

[0099] Accordingly, the wire connecting between the first ends **15a** of the crack sensing lines **150M1** and **150M2** and the input pads **70a** and **70b** and the wire connecting between the test gate line **81** and the input pads **80a** and **80b** may cross the bending area **BDA**. The wires crossing the bending area **BDA** may include at least one contact part located around the upper and lower sides of the bending area **BDA**. The contact part may include at least one contact hole.

[0100] FIG. 5 is a top plan view of a display panel included in a display device according to an embodiment. A display panel **1000c** illustrated in FIG. 5 may include features and/or structures discussed with reference to one of more of FIG. 1, FIG. 2, FIG. 3, and FIG. 4. However, the display panel **1000c** may include bending crack sensing lines **150M3** and **150M4**.

[0101] The bending crack sensing lines **150M3** and **150M4** used to detect whether the defect such as the crack of the bending area BDA occurs or not, unlike the crack sensing lines **150M1** and **150M2** described above, may be located to be substantially limited to the bending area BDA and its surroundings. In detail, the bending crack sensing lines **150M3** and **150M4** may each be positioned at the right/left edge areas of the bending area BDA, and may each start from one end **15c** connected to the pad area **660**, extend in the approximate y direction, reciprocate once or more times within the bending area BDA to form the bending part, and then be returned to be connected to the circuit area **650** at the another end **15d**. One end **15c** of each of the bending crack sensing lines **150M3** and **150M4** may be connected to the pad area **660**, thereby receiving the test voltage.

[0102] When the cross-sectional position of the conductive layer positioned at the bending area BDA and the cross-sectional position of the bending crack sensing lines **150M3** and **150M4** positioned outside the bending area BDA are not same to each other, the bending crack sensing lines **150M3** and **150M4** may include at least one contact part located around the upper and lower sides of the bending area BDA. The bending crack sensing lines **150M3** and **150M4** may include parts positioned at different layers from each other on a cross-section based on the contact part. The contact part may include at least one contact hole.

[0103] In FIG. 5, the above-described crack sensing lines **150M1** and **150M2** are omitted and only the bending crack sensing lines **150M3** and **150M4** are shown. In an embodiment, the crack sensing lines **150M1** and **150M2** may also be included along with the bending crack sensing lines **150M3** and **150M4**. In an embodiment, an additional crack sensing circuit connected to the crack sensing lines **150M1** and **150M2** may be further formed, and a configuration of this additional crack sensing circuit may be the same as that of the crack sensing circuit of the circuit area **650**. In an embodiment, in the bending area BDA, the bending crack sensing line **150M3** positioned at the left side may be positioned between the crack sensing line **150M1** and the edge of the substrate **110**, and the bending crack sensing line **150M4** positioned at the right side may be positioned between the crack sensing line **150M2** and the edge of the substrate **110**.

[0104] The configuration like the connection relationship of the bending crack sensing lines **150M3** and **150M4** and the circuit area **650** of the display panel **1000c** according to an embodiment and the effects thereof may be identical to or analogous to the configuration like the connection relationship of the crack sensing lines **150M1** and **150M2** and the circuit area **650** of the above-described display panels **1000**, **1000a**, and **1000b** and the effects thereof.

[0105] One or more methods of testing a defect, such as a crack, of one of the display panels **1000**, **1000a**, **1000b**, and **1000c** according to one or more embodiments are described as follows.

[0106] First, a test voltage is applied to one end **15a** and/or **15c** of the crack sensing lines **150M1** and **150M2** and/or the bending crack sensing lines **150M3** and **150M4**, and the test data lines **71a** and **71b** through the pad area **660**. Along with this, if the gate signal of the gate-on voltage is applied to the test gate line **81**, the switching elements **Q1** and **Q2** of the circuit area **650** are turned on, and the test voltage applied to the test data lines **71a** and **71b** is applied to the corresponding data line **171** through the turned-on switching

element **Q1**. The test voltage as a predetermined voltage may be, for example, a voltage to display the pixel PX with a lowest gray, and in this case, it may be an approximately 7 V. Accordingly, the pixels PX connected to the turned-on switching element **Q1** may display the low gray such as black.

[0107] If the crack, the lifting, etc. are not generated in the peripheral area PA and/or the bending area BDA of the display panels **1000**, **1000a**, **1000b**, and **1000c**, i.e., if they are in the normal state that the damage is not applied to the crack sensing lines **150M1** and **150M2** and/or the bending crack sensing lines **150M3** and **150M4**, the voltage applied to the test data lines **91a** and **91b** of the circuit area **650** through the crack sensing lines **150M1** and **150M2** and/or the bending crack sensing lines **150M3** and **150M4** may be substantially the same as the voltage applied to the test data lines **71a** and **71b**. For this, the matching resistors **R1** and **R2** may be controlled. In this case, the pixels PX connected to the switching element **Q2** may also display the predetermined gray such as black like the pixels PX connected to the switching element **Q1**.

[0108] However, if the crack, the lifting/protrusion, etc. are generated in the peripheral area PA and/or the bending area BDA of the display panels **1000**, **1000a**, **1000b**, and **1000c**, i.e., if the crack sensing lines **150M1** and **150M2** and/or the bending crack sensing lines **150M3** and **150M4** are disconnected or damaged such that the wire resistance is increased, a black data voltage is not applied to the pixels PX connected to the switching element **Q2** or the black data voltage is not sufficiently applied. According, a hard white line or a weak white line may be recognized along the column of the pixels PX connected to the switching element **Q2**. As above-described, the defect such as the crack generated in the peripheral area PA and/or the bending area BDA of the display panels **1000**, **1000a**, **1000b**, and **1000c** may be detected through the recognized white line.

[0109] FIG. 6 is a cross-sectional view of a display device taken along a line I-Ia shown in FIG. 1 according to an embodiment. The cross-sectional structure of the display device is described with reference to FIG. 6 along with one or more of FIG. 1 to FIG. 5.

[0110] Referring to FIG. 6, a barrier layer **120** may be positioned on a substrate **110**. The barrier layer **120** may include a plurality of layers or may be made of a single layer as shown in the drawing.

[0111] An active pattern is positioned on the barrier layer **120**. The active pattern may include an active pattern **130** positioned at the display area DA and an active pattern **130d** positioned at the peripheral area PA. Each of the active patterns **130** and **130d** may include a source region, a drain region, and a channel region between the source region and the drain region. The active pattern may include amorphous silicon, polysilicon, or an oxide semiconductor.

[0112] A first insulating layer **141** may be positioned on the active patterns **130** and **130d**, and a first conductive layer may be positioned on the first insulating layer **141**.

[0113] The first conductive layer may include a conductor **155** overlapping the active pattern **130** positioned at the display area DA, a conductor **150d** overlapping the active pattern **130d** positioned at the peripheral area PA, and the plurality of gate lines **121** and the test gate line **81** as above-described.

[0114] The active pattern **130** and the conductor **155** overlapping thereto may together form a transistor TRa, and

the active pattern **130d** and the conductor **150d** overlapping thereto may together form a transistor TRd. The transistor TRa may function as a switching element included in the pixel PX positioned at the display area DA, and the transistor TRd may function as a switching element included in the gate drivers **400a** and **400b**.

[0115] A second insulating layer **142** may be positioned on the first conductive layer and the first insulating layer **141**, and a second conductive layer may be positioned on the second insulating layer **142**. The second conductive layer may include the above-described crack sensing lines **150M1** and **150M2**. Alternatively, the crack sensing lines **150M1** and **150M2** may be positioned at the same layer as and may include the same material as the first conductive layer.

[0116] The second conductive layer may further include the above-described test data lines **71a**, **71b**, **91a**, and **91b**, and the like. Alternatively, at least one among the test data lines **71a**, **71b**, **91a**, and **91b** may be positioned at the first conductive layer.

[0117] A third insulating layer **160** may be positioned on the second conductive layer and second insulating layer **142**.

[0118] At least one among the first insulating layer **141**, the second insulating layer **142**, and the third insulating layer **160** may include an inorganic insulating material such as silicon nitride (SiN_x), silicon oxide (SiO_x), silicon oxynitride (SiON), and/or an organic insulating material. A part or entire of at least one of the first insulating layer **141**, the second insulating layer **142**, and the third insulating layer **160** may be removed in the bending area BDA.

[0119] The first insulating layer **141**, the second insulating layer **142**, and the third insulating layer **160** may include contact holes **165** and **165d** positioned at the source region and/or the drain region of the transistors TRa and TRd.

[0120] A third conductive layer may be positioned on the third insulating layer **160**. The third conductive layer may include conductor **170** connected to the source area or the drain area of the transistor TRa through the contact hole **165** and conductor **170d** connected to the source area or the drain area of the transistor TRd through the contact hole **165**, a voltage transmitting line **177**, and the above-described data line **171**.

[0121] At least one among the first conductive layer, the second conductive layer, and the third conductive layer may include a metal such as copper (Cu), aluminum (Al), molybdenum (Mo), or an alloy.

[0122] A passivation layer **180** is positioned on the third conductive layer and the third insulating layer **160**. The passivation layer **180** may include the inorganic insulating material and/or the organic insulating material such as a polyacrylic resin and a polyimide-based resin, and an upper surface of the passivation layer **180** may be substantially flat.

[0123] A pixel electrode layer is positioned on the passivation layer **180**. The pixel electrode layer may include a pixel electrode **191** corresponding to each pixel PX of the display area DA, and a voltage transmitting electrode **197** positioned at the peripheral area PA. The voltage transmitting electrode **197** may be physically and electrically connected to the voltage transmitting line **177**, thereby receiving a common voltage. The pixel electrode layer may include a semi-transmissive conductive material or a reflective conductive material.

[0124] A pixel definition layer **350** is positioned on the passivation layer **180** and the pixel electrode layer. The pixel definition layer **350** may have an opening **351** formed on the

pixel electrode **191**, and may further include at least one dam portion **350d** positioned at the peripheral area PA. The dam portion **350d** may extend to be parallel to the edge of the substrate **110** in a plan view. A spacer **360d** may be further positioned on the dam portion **350d**.

[0125] The crack sensing lines **150M1** and **150M2** may be positioned outside with respect to the dam portion **350d**, but are not limited thereto.

[0126] The pixel definition layer **350** may include a photosensitive material such as the polyacrylic resin and the polyimide-based resin.

[0127] An emission layer **370** is positioned on the pixel electrode **191**. The emission layer **370** may include a portion positioned in the opening **351** of the pixel definition layer **350**. The emission layer **370** may further include at least one dummy emission layer **370d** positioned at the peripheral area PA and positioned on the pixel definition layer **350**. The emission layer **370** may include an organic emission material or an inorganic emission material.

[0128] A common electrode **270** is positioned on the emission layer **370**. The common electrode **270** is also formed on the pixel definition layer **350**. The common electrodes **270** may be continuously formed throughout the plurality of pixels PX. The common electrode **270** may be physically and electrically connected to the voltage transmitting electrode **197** in the peripheral area PA, thereby receiving the common voltage. The common electrode **270** may include a conductive transparent material.

[0129] The pixel electrode **191**, the emission layer **370**, and the common electrode **270** of each pixel PX together form a light emitting diode (LED) ED, one of the pixel electrode **191** and the common electrode **270** becomes a cathode while the other becomes an anode.

[0130] An encapsulating portion **380** protecting and encapsulating the light emitting diode (LED) ED may be positioned on the common electrode **270**. The encapsulating portion **380** includes at least one of inorganic layers **381** and **383** and at least one organic layer **382**, and the at least one of the inorganic layers **381** and **383** and the at least one organic layer **382** may be alternately stacked. The organic layer **382** includes the organic material and may have a flattening characteristic. The inorganic layers **381** and **383** may include an inorganic material such as an aluminum oxide (AlO_x), a silicon oxide (SiO_x), a silicon nitride (SiN_x), and a silicon oxynitride (SiON).

[0131] Since a plane area of the inorganic layers **381** and **383** is wider than a plane area of the organic layer **382**, the two inorganic layers **381** and **383** may be vertically in contact with each other in the peripheral area PA. The inorganic layer **381** positioned at the bottom of the inorganic layers **381** and **383** may be in contact with the upper surface of the third insulating layer **160** in the peripheral area PA, but it is not limited thereto. In the peripheral area PA, the encapsulating portion **380** including the inorganic layers **381** and **383** may overlap the crack sensing lines **150M1** and **150M2**.

[0132] The edge of the organic layer **382** included in the encapsulating portion **380** may be positioned between the dam portion **350d** and the display area DA. The dam portion **350d** may function to prevent the organic material from overflowing outside when forming the organic layer **382** of the encapsulating portion **380**, and accordingly the outer

edge of the organic layer **382** of the encapsulating portion **380** may be substantially positioned more inside than the dam portion **350d**.

[0133] A buffer layer **389** including the inorganic insulating material or/and the organic insulating material may be positioned on the encapsulating portion **380**. The buffer layer **389** may be omitted.

[0134] A fourth conductive layer is positioned on the buffer layer **389**. The fourth conductive layer may include a first touch conductor TEa. A first touch insulating layer **391** may be positioned on the fourth conductive layer, and a fifth conductive layer may be positioned thereon. The fifth conductive layer may include a second touch conductor TEb. A second touch insulating layer **392** may be positioned on the fifth conductive layer. As the first touch conductor TEa or/and the second touch conductor TEb form a capacitive touch sensor, the touch of an external object may be sensed. At least one of the first touch conductor TEa and the second touch conductor TEb may be omitted.

[0135] FIG. 7 is a layout view of a part of a circuit area of a display panel according to an embodiment. Structures of a static electricity discharge element **92a** of one or more of the display panels **1000**, **1000a**, **1000b**, and **1000c** according to one or more embodiments are described with reference to FIG. 7 and FIG. 8 as well as one or more of FIGS. 1 to 6.

[0136] FIG. 7 shows a left portion among the center area **650C** of the circuit area **650** of one or more of the display panels **1000**, **1000a**, **1000b**, and **1000c**. FIG. 8 is a cross-sectional view of a display panel taken along a line VII-VIIa shown in FIG. 7 according to an embodiment. The test data line **91a** may include a plurality of sub-wires **91aa** and **91ab**, and each of the sub-wires **91aa** and **91ab** is connected to one of static electricity discharge elements **92aa** and **92ab** positioned in the center area **650C**. The static electricity discharge elements **92aa** and **92ab** are included in the static electricity discharge element **92a**.

[0137] Each of the static electricity discharge elements **92aa** and **92ab** includes at least one capacitor.

[0138] The static electricity discharge element **92aa** may include a first terminal **158** connected to an end of the sub-wire **91aa** of the test data line **91a**, a second terminal **178** connected to the test data line **71a** (or the connection wire **73a** shown in FIG. 3), and a third terminal **131h**.

[0139] Referring to FIG. 7 and FIG. 8, the first terminal **158** and the second terminal **178** overlap each other and are separated by at least one insulating layer, for example, via the second insulating layer **142** and the third insulating layer **160**, to form the first capacitor **C1**, which may store and discharge static electricity. The first terminal **158** and the third terminal **131h** may overlap each other and may be separated by at least one insulating layer, for example, the first insulating layer **141**, to form a second capacitor **C2**, which may store and discharge static electricity. The first terminal **158** and the second terminal **178** are conductive, and the third terminal **131h** may be a semiconductor. The first terminal **158** may be positioned in the above-described first conductive layer, the second terminal **178** may be positioned in the above-described third conductive layer, and the third terminal **131h** may be included in the above-described active patterns **130** and **130d**. Conductive areas **136h** and **137h** are positioned at opposite sides of the third terminal **131h**, and the conductive areas **136h** and **137h** may be connected to the third terminal **131h**. The second terminal **178** may be connected to the conductive areas **136h** and

137h through contact holes **66** included in the first to third insulating layers **141**, **142**, and **160**. Accordingly, the conductive area **136h** and **137h** may receive the voltage of the input pad **70a** transmitted by the test data line **71a** (or the connection wire **73a**) along with the second terminal **178**. The second terminal **178** may be connected to the test data line **71a** (or the connection wire **73a**) through a connection wire **711**.

[0140] Similarly, the static electricity discharge element **92ab** may include a first terminal **158a** connected to an end of the sub-wire **91ab** of the test data line **91a**, a second terminal **178a** connected to the test data line **71a** (or the connection wire **73a**), and a third terminal **131ha**.

[0141] The first terminal **158a** and the second terminal **178a** may overlap each other and may be separated by at least one insulating layer, for example the second insulating layer **142** and the third insulating layer **160**, to form the first capacitor **C1a**, which may store and discharge static electricity. The first terminal **158a** and the third terminal **131ha** may overlap each other and may be separated by at least one insulating layer, for example, the first insulating layer **141**, to form the second capacitor **C2a**, which may store and discharge static electricity. The first terminal **158a** and the second terminal **178a** may be conductive, and the third terminal **131ha** may be a semiconductor. The first terminal **158a** may be positioned in the first conductive layer, the second terminal **178a** may be positioned in the third conductive layer, and the third terminal **131ha** may be included in the above-described active patterns **130** and **130d**. Conductive areas **136ha** and **137ha** may be positioned at opposite sides of the third terminal **131ha**, and the conductive areas **136ha** and **137ha** may be connected to the third terminal **131ha**. The second terminal **178a** may be connected to the conductive areas **136ha** and **137ha** through contact holes **66a** included in the first to third insulating layers **141**, **142**, and **160**. Accordingly, the conductive areas **136ha** and **137ha** may receive the voltage of the input pad **70a** transmitted by the test data line **71a** (or the connection wire **73a**) along with the second terminal **178a**. The second terminal **178a** may be directly connected to the test data line **71a** (or the connection wire **73a**).

[0142] As described above, the static electricity discharge element **92aa** may include the first and second capacitors **C1** and **C2**, and the static electricity discharge element **92ab** may include the first and second capacitors **C1a** and **C2a**. The first and second capacitors **C1**, **C1a**, **C2**, and **C2a** may be referred to as sub-capacitors.

[0143] The third terminals **131h** and **131ha** and the second capacitors **C2** and **C2a** may be unnecessary in an embodiment.

[0144] FIG. 9 is a layout view of a part of a circuit area of a display panel according to an embodiment. FIG. 9 shows the left portion among the center area **650C** of the circuit area **650** of one or more of the display panels **1000**, **1000a**, **1000b**, and **1000c** according to one or more embodiments. The test data line **91a** may include a plurality of sub-wires **91ac**, **91ad**, **91ae**, and **91af**. A pair of sub-wires **91ac** and **91af** may be connected with each other through a connection wire **714**, and a pair of sub-wires **91ad** and **91ae** may be connected with each other through a connection wire **713**. In the center area **650C**, the sub-wires **91ac** and **91af** are connected to the static electricity discharge element **92ac**, and the sub-wires **91ad** and **91ae** are connected to the static electricity discharge element **92ad**. The static electricity

discharge element **92ac** and **92ad** are included in the static electricity discharge element **92a**.

[0145] Each of the static electricity discharge elements **92ac** and **92ad** includes at least one capacitor.

[0146] The static electricity discharge element **92ac** may include a first terminal **158b** connected to an end of each of the sub-wires **91ac** and **91af** of the test data line **91a**, a second terminal **178b** connected to the test data line **71a** (or the connection wire **73a**), and a third terminal **131hb**. The first terminal **158b** and the second terminal **178b** form the first capacitor **C1b**, and the first terminal **158b** and the third terminal **131hb** form the second capacitor **C2b**, for storing and discharging static electricity. The first terminal **158b** and the second terminal **178b** may be conductive, and the third terminal **131hb** may be a semiconductor. Conductive areas **136hb** and **137hb** may be positioned at opposite sides of the third terminal **131hb**, and the conductive areas **136hb** and **137hb** may be connected to the third terminal **131hb**. The second terminal **178b** may be connected to the conductive areas **136hb** and **137hb** through contact holes **66b**.

[0147] Similarly, the static electricity discharge element **92ad** may include a first terminal **158c** connected to an end of each of the sub-wires **91ad** and **91ae** of the test data line **91a**, a second terminal **178c** connected to the test data line **71a** (or the connection wire **73a**), and a third terminal **131hc**. The first terminal **158c** and the second terminal **178c** form the first capacitor **C1c**, and the first terminal **158c** and the third terminal **131hc** form the second capacitor **C2c**, for storing and discharging static electricity. The first terminal **158c** and the second terminal **178c** may be conductive, and the third terminal **131hc** may be a semiconductor. Conductive areas **136hc** and **137hc** may be positioned at opposite sides of the third terminal **131hc**, and the conductive areas **136hc** and **137hc** may be connected to the third terminal **131hc**. The second terminal **178c** may be connected to the conductive areas **136hc** and **137hc** through contact holes **66c**. The second terminal **178c** may be connected to the test data line **71a** (or the connection wire **73a**) through a connection wire **712**.

[0148] As described above, the static electricity discharge element **92ac** may include the first and second capacitors **C1b** and **C2b**, and the static electricity discharge element **92ad** may include the first and second capacitors **C1c** and **C2c**.

[0149] The third terminals **131hb** and **131hc** and the second capacitors **C2b** and **C2c** may be unnecessary in an embodiment.

[0150] The display device according to an embodiment may be, for example, an organic/inorganic emissive display device or a liquid crystal display.

[0151] While example embodiments have been described, practical embodiments are not limited to the described embodiments. Embodiments are intended to cover various modifications and equivalent arrangements within the spirit and scope defined by the appended claims.

1. (canceled)

2. A display device comprising:

a substrate comprising a display area and a peripheral area, the peripheral area including a pad area and a bending area;

a plurality of data lines extending in the display area and the peripheral area;

a first detection line positioned in the peripheral area and electrically connected to at least one data line of the plurality of data lines;

a first line crossing at least one data line of the plurality of data lines; and

a first static electricity discharge element, wherein the first detection line includes at least one curved portion forming a loop located in the peripheral area, and one end of the first detection line is electrically connected to the pad area, and another end of the first detection line is electrically connected to the first static electricity discharge element.

3. The display device of claim 2, wherein

the pad area comprises a plurality of input pads, and the one end of the first detection line electrically connected to the pad area is connected to the first line.

4. The display device of claim 2, further comprising: a resistor between the one end of the first detection line and the first line.

5. The display device of claim 2, further comprising: a second detection line positioned in the peripheral area, wherein

the first detection line opposes the second detection line with the display area between the first detection line and the second detection line.

6. The display device of claim 5, wherein

the second detection line includes at least one curved portion forming a loop located in the peripheral area, and

the curved portion of the second detection line and the curved portion of the first detection line face each other in the peripheral area.

7. The display device of claim 5, wherein

the first detection line and the second detection line are symmetrical to each other.

8. The display device of claim 5, further comprising: a second static electricity discharge element separated from the first static electricity discharge element, wherein

the second detection line is electrically connected to the second static electricity discharge element.

9. The display device of claim 8, wherein

the first static electricity discharge element and the second static electricity discharge element are symmetrical to each other.

10. The display device of claim 2, wherein

the first detection line overlaps at least a portion of a bending area.

11. The display device of claim 10, wherein

the bending area is disposed between the display area and the pad area.

12. The display device of claim 11, wherein

the bending area is disposed between the display area and the first static electricity discharge element.

13. The display device of claim 2, further comprising:

a first switching element, wherein an input terminal of the first switching element is electrically connected to one end of the first detection line, and

an output terminal of the first switching element is electrically connected to a first data line of the plurality of data lines.

- 14.** The display device of claim **13**, further comprising:
a second switching element, wherein an input terminal of the second switching element is electrically connected to another end of the first detection line, and
an output terminal of the second switching element is electrically connected to a second data line of the plurality of data lines.
- 15.** The display device of claim **2**, further comprising:
a second line crossing at least one data line of the plurality of data lines, wherein
the first line and the second line are spaced apart from each other and not electrically connected to each other.
- 16.** The display device of claim **15**, wherein
the first static electricity discharge element is disposed between the first line and the second line.
- 17.** The display device of claim **16**, wherein
the first line and the second line are aligned with each other in a first direction.
- 18.** The display device of claim **2**, wherein
the first line is shorter than the first detection line.
- 19.** The display device of claim **2**, wherein
the first static electricity discharge element comprises a first capacitor electrically connected to the first line.
- 20.** The display device of claim **2**, further comprising
a connection wire electrically connected to the first detection line and extending parallel to the first line, wherein
the first static electricity discharge element is electrically connected through the connection wire to the first line.
- 21.** The display device of claim **2**, further comprising:
a voltage transmitting line positioned between the first detection line and the display area.

* * * * *