



(19) **United States**

(12) **Patent Application Publication**
Elliott et al.

(10) **Pub. No.: US 2020/0290013 A1**
(43) **Pub. Date: Sep. 17, 2020**

(54) **COMPOSITIONS FOR CARBON DIOXIDE SEPARATION USING STEAM REGENERATION, AND METHOD FOR PREPARING SAME**

Publication Classification

- (51) **Int. Cl.**
B01J 20/04 (2006.01)
B01J 20/20 (2006.01)
B01J 20/08 (2006.01)
B01J 20/34 (2006.01)
B01J 20/32 (2006.01)
- (52) **U.S. Cl.**
 CPC *B01J 20/043* (2013.01); *B01J 20/20* (2013.01); *B01J 20/08* (2013.01); *B01J 20/3466* (2013.01); *B01J 20/3236* (2013.01); *B01J 2220/603* (2013.01); *B01J 20/3204* (2013.01); *B01J 20/041* (2013.01); *B01J 20/3491* (2013.01); *Y02C 10/08* (2013.01); *B01J 2220/606* (2013.01); *B01J 20/3483* (2013.01)

(71) Applicants: **ExxonMobil Research and Engineering Company**, Annandale, NJ (US); **TDA Research, Inc.**, Wheat Ridge, CO (US)

(72) Inventors: **Jeannine Elizabeth Elliott**, Superior, CO (US); **Robert James Copeland**, Arvada, CO (US); **Margarita Dubovik**, Denver, CO (US); **Daniel P. Leta**, Flemington, NJ (US); **Patrick P. McCall**, Matawan, NJ (US); **Chuansheng Bai**, Phillipsburg, NJ (US); **Bruce A. DeRites**, Pittstown, NJ (US)

(21) Appl. No.: **16/889,657**

(22) Filed: **Jun. 1, 2020**

Related U.S. Application Data

- (63) Continuation of application No. 14/325,654, filed on Jul. 8, 2014.
- (60) Provisional application No. 61/843,759, filed on Jul. 8, 2013.

(57) **ABSTRACT**

Compositions and methods of preparing the compositions are disclosed for sorbents and other surfaces that can adsorb and desorb carbon dioxide. A sorbent or surface can include a metal compound such as an alkali or alkaline earth compound and a support. The sorbent can be prepared by several methods, including an incipient wetness technique. The sorbents have a CO₂ adsorption and desorption profile. A sorbent having high levels of a metal compound and adsorbed CO₂ is disclosed.

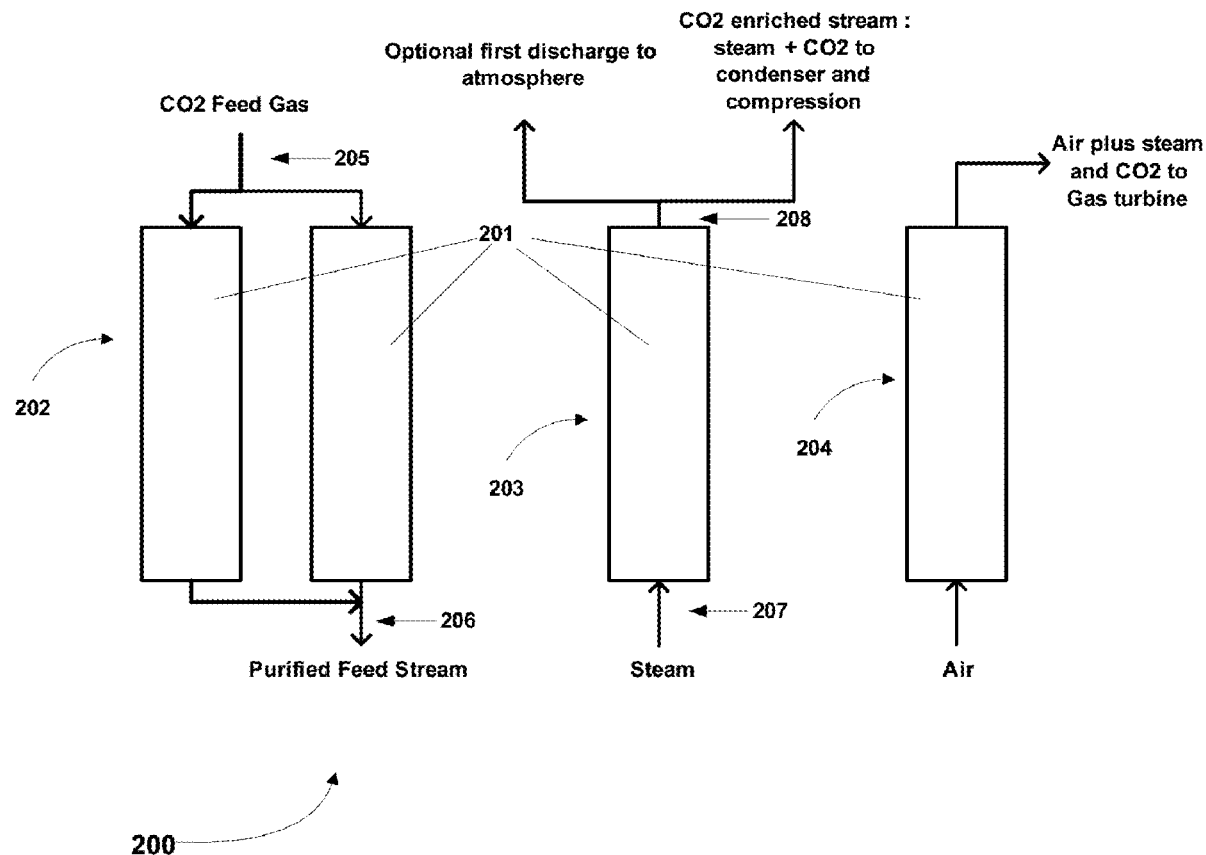

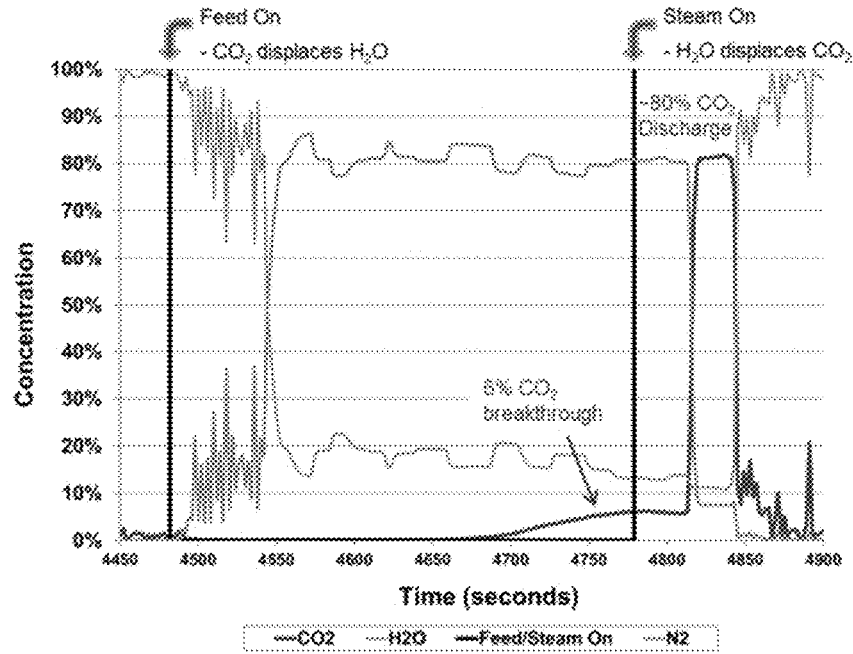

FIG. 1

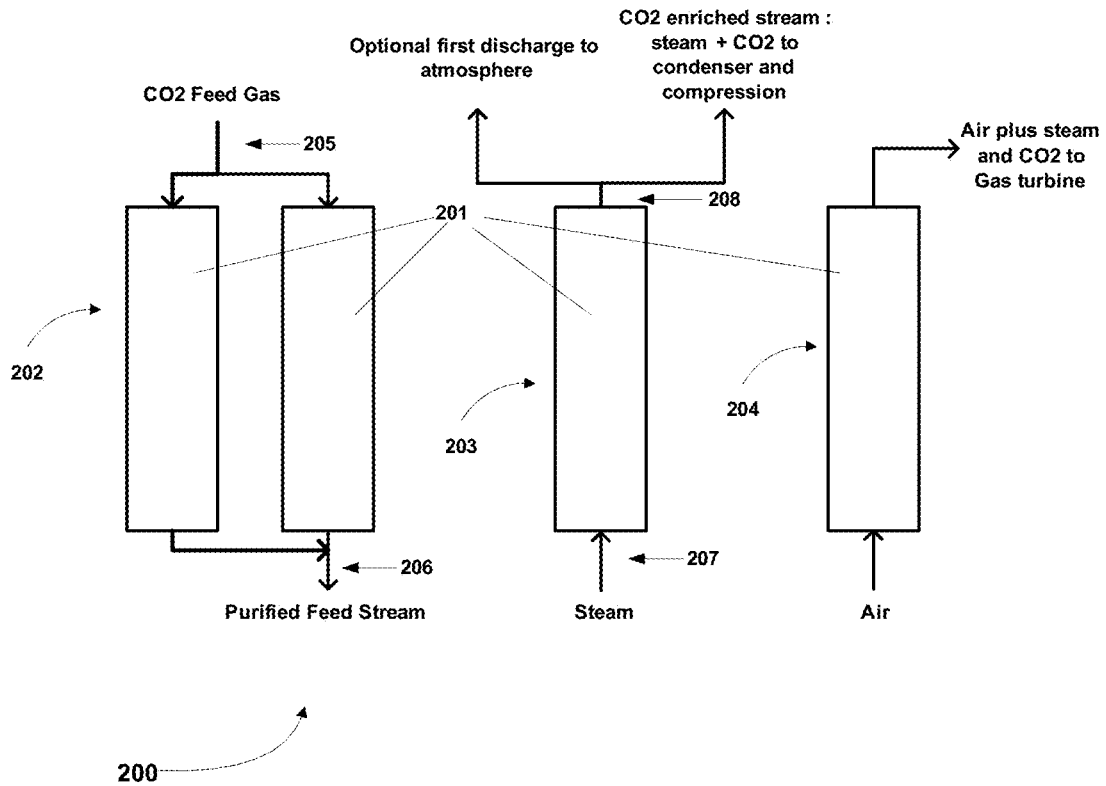

FIG. 2

5 Bed CDS Arrangement Showing Valves

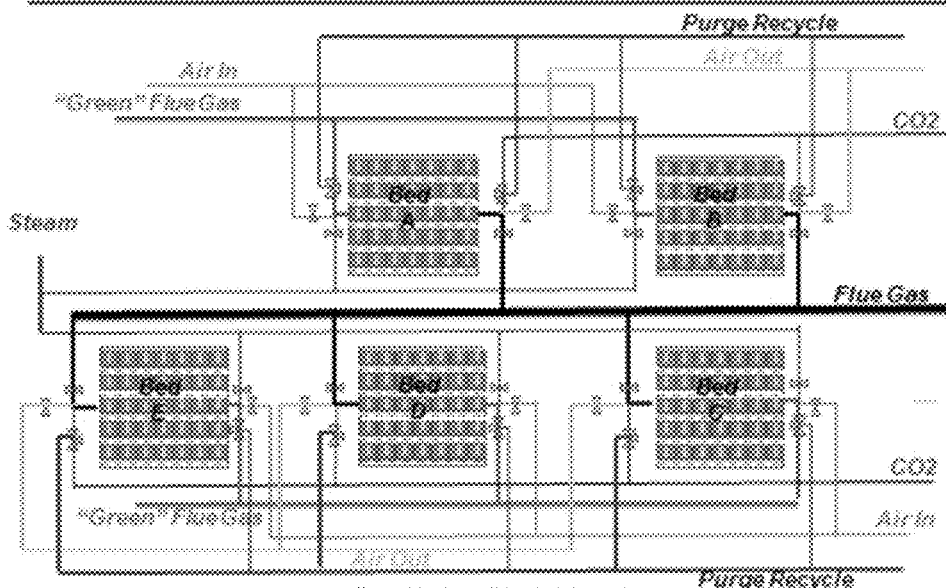

FIG 3A

Valve Positions in Step n

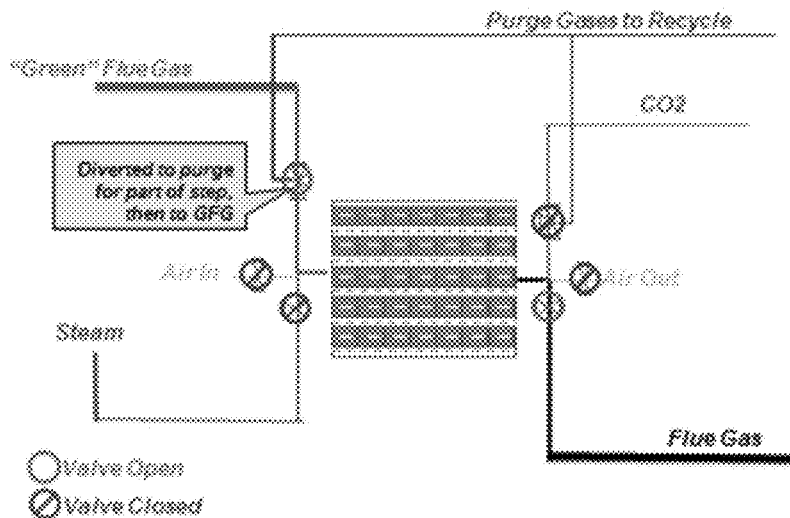

FIG. 3B

Valve Positions in Step n + 1

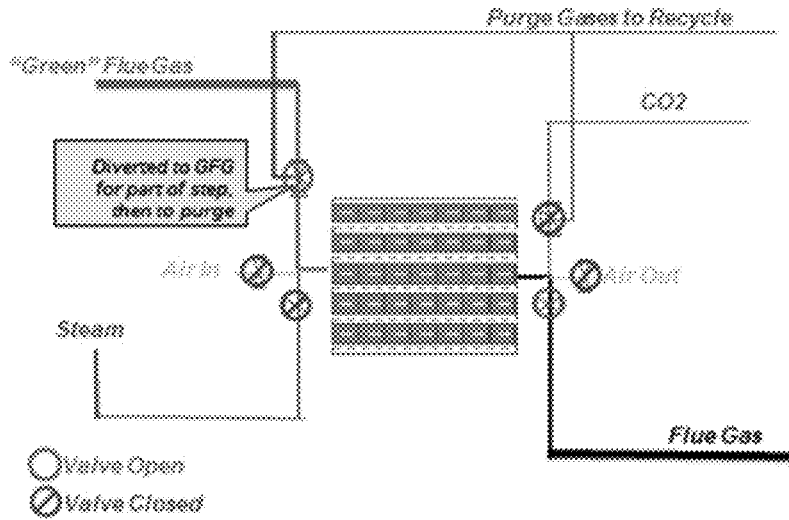

FIG. 3C

Valve Positions in Step n + 2

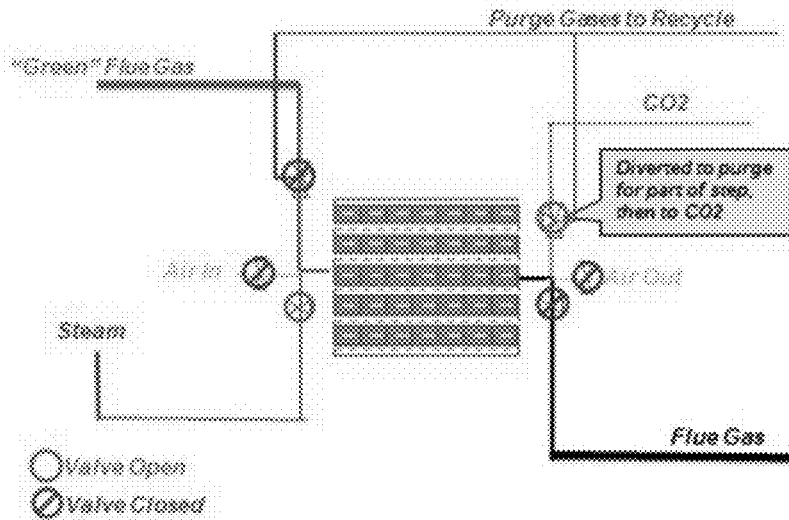

FIG. 3D

Valve Positions in Step n + 3

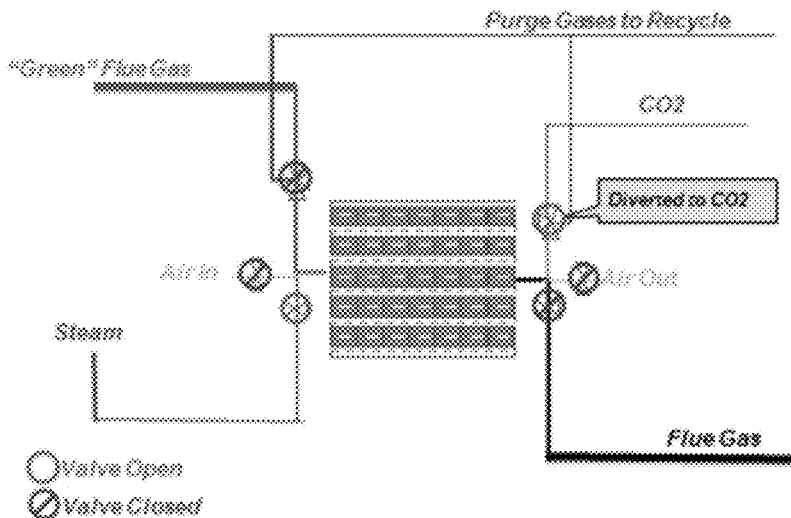

FIG. 3E

Valve Positions in Step n + 4

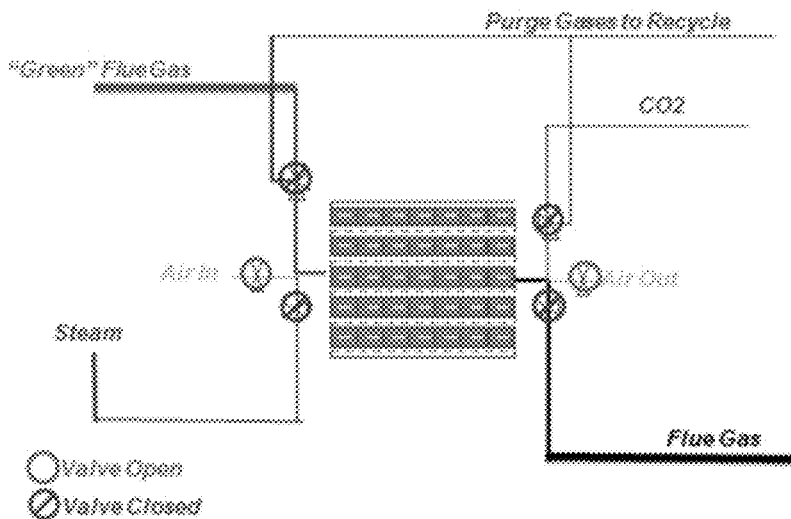

FIG. 3F

Individual Bed with Valves

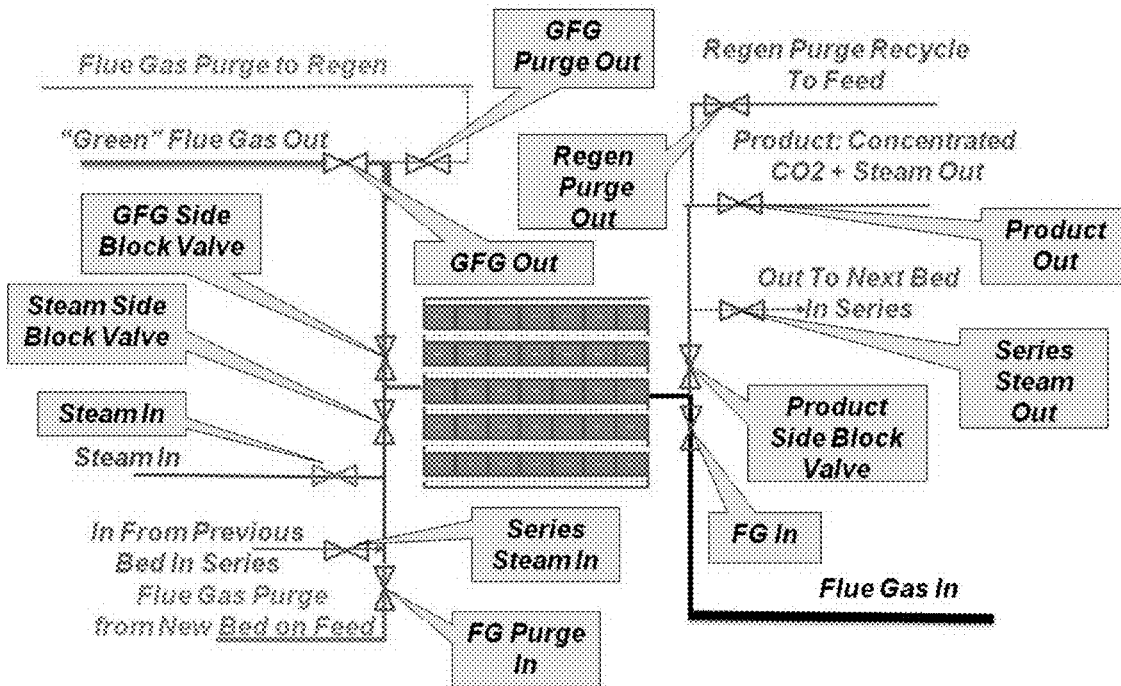

FIG. 4A

Valve Positions Pattern A

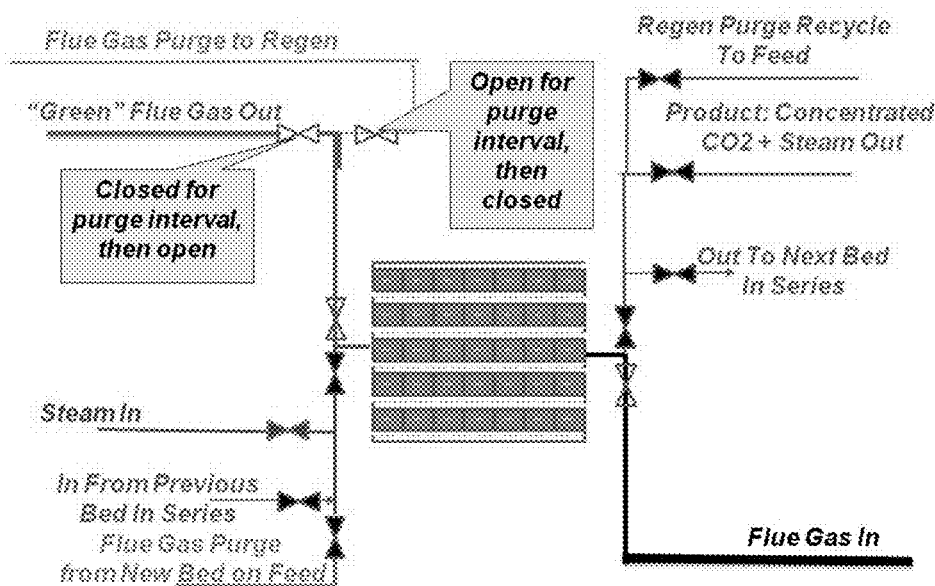

FIG. 4B

Valve Positions Pattern B

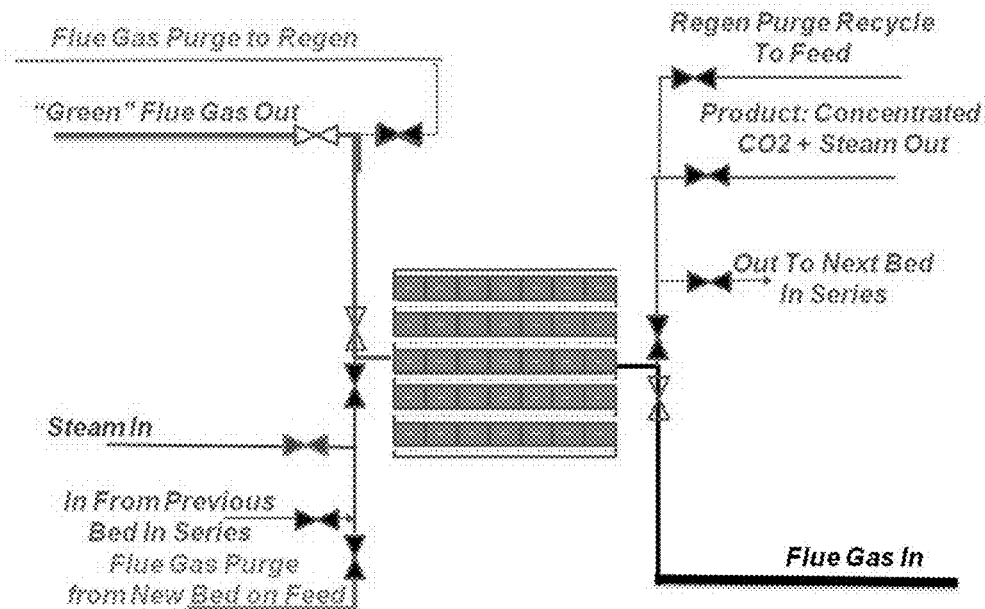

FIG 4C

Valve Positions Pattern C

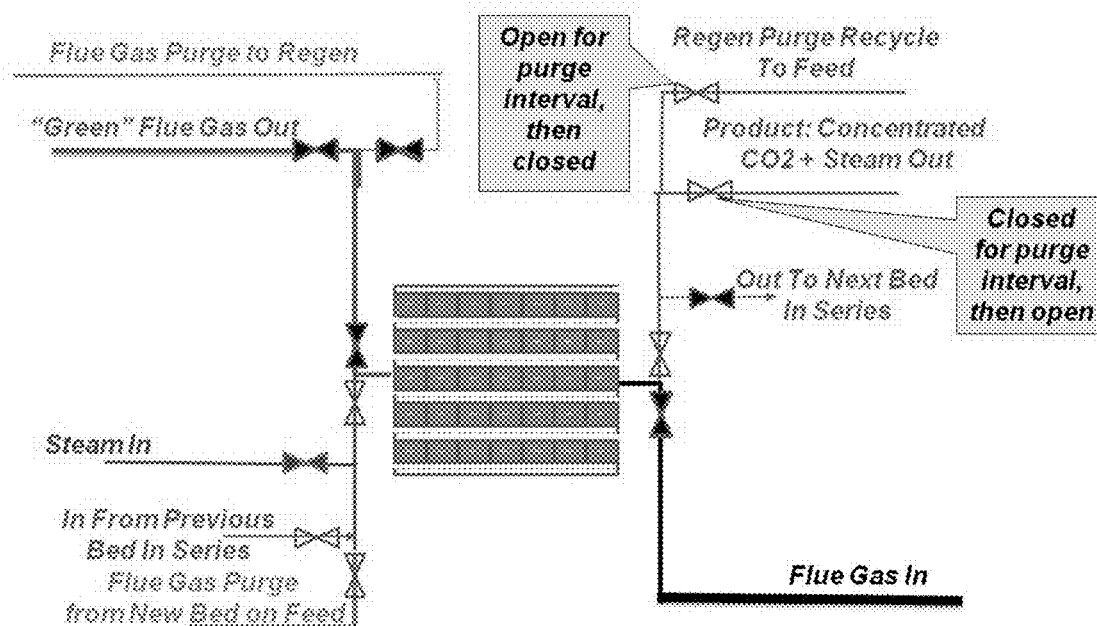

FIG. 4D

Valve Positions Pattern D

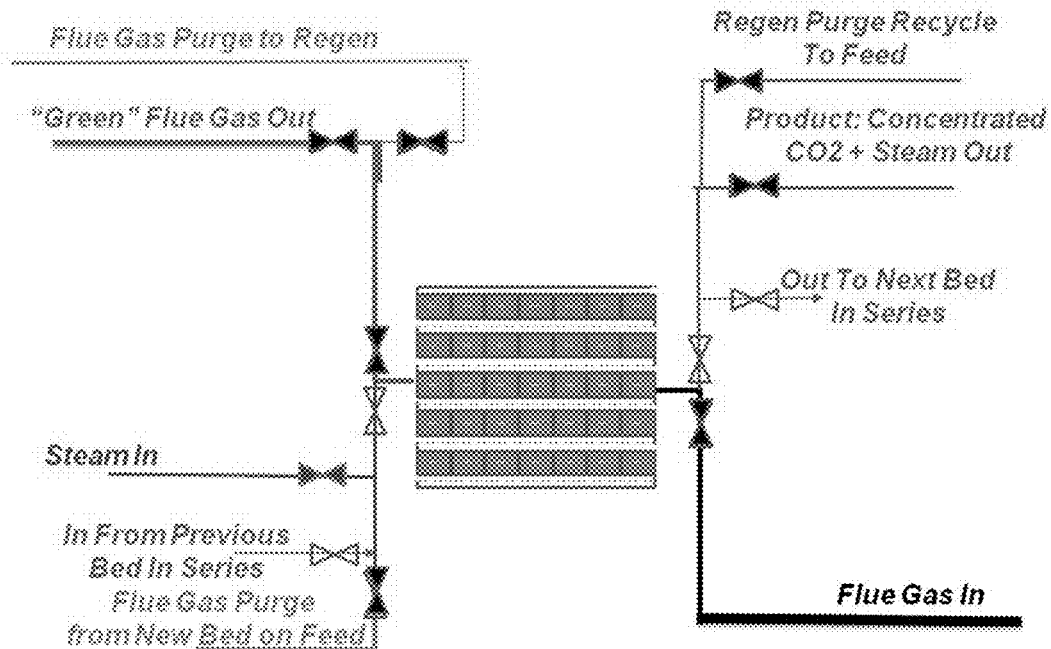

FIG. 4E

Valve Positions Pattern E

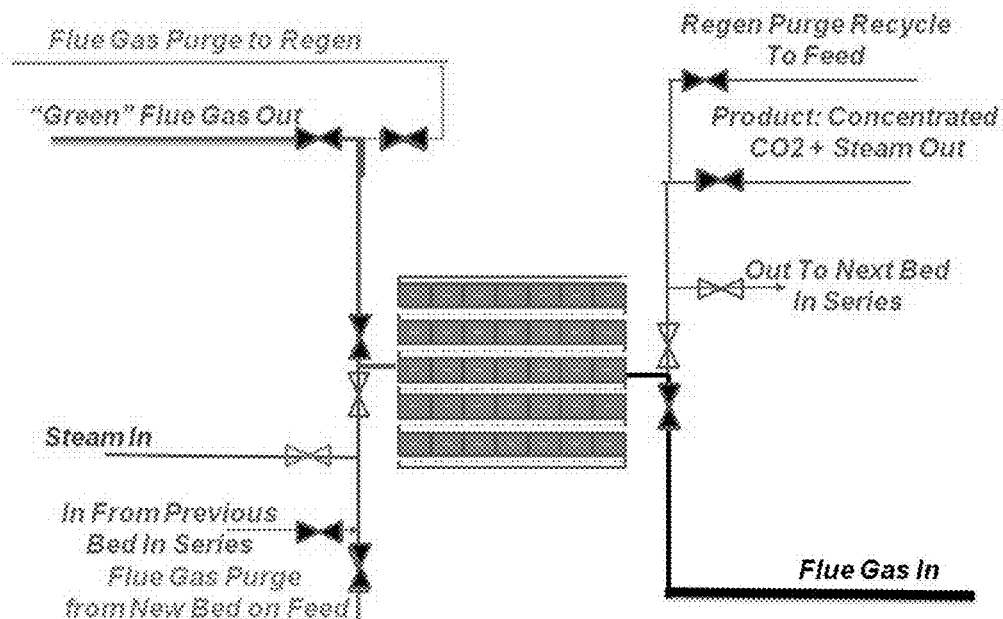

FIG. 4F

8 Bed Arrangement Showing Valves

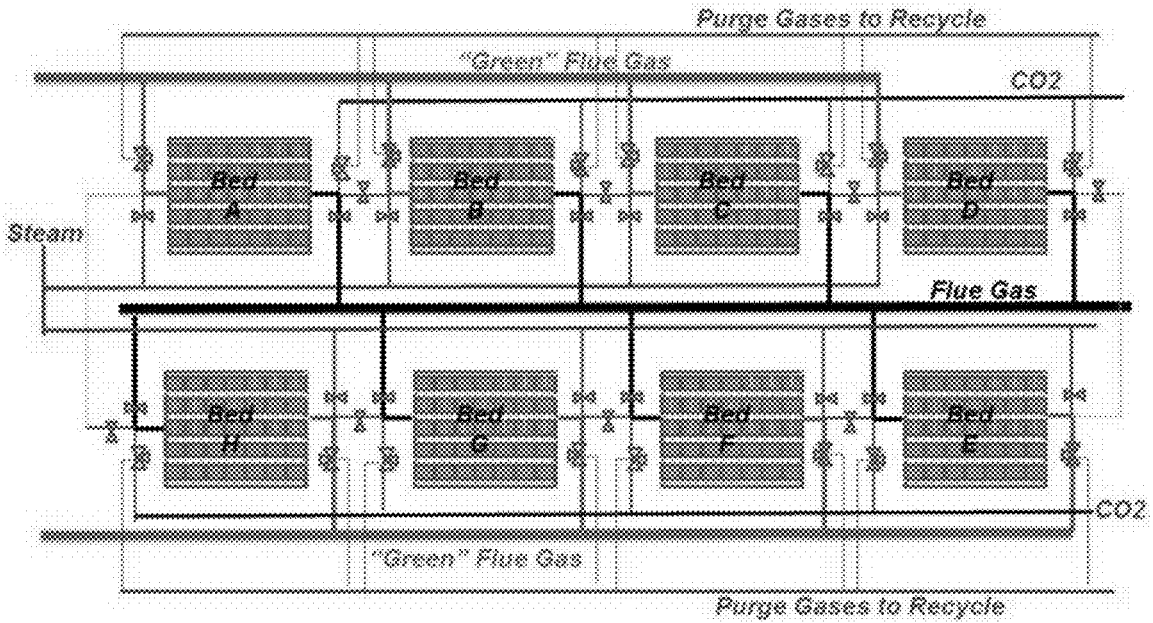

FIG. 5A

Valve Nomenclature

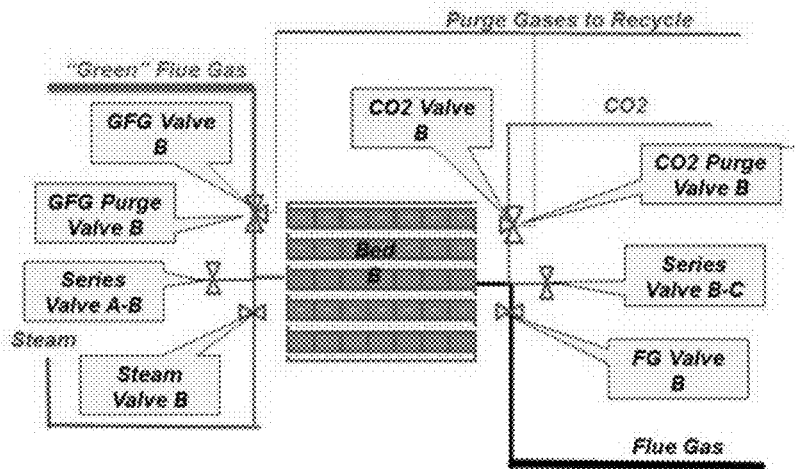

FIG. 5B

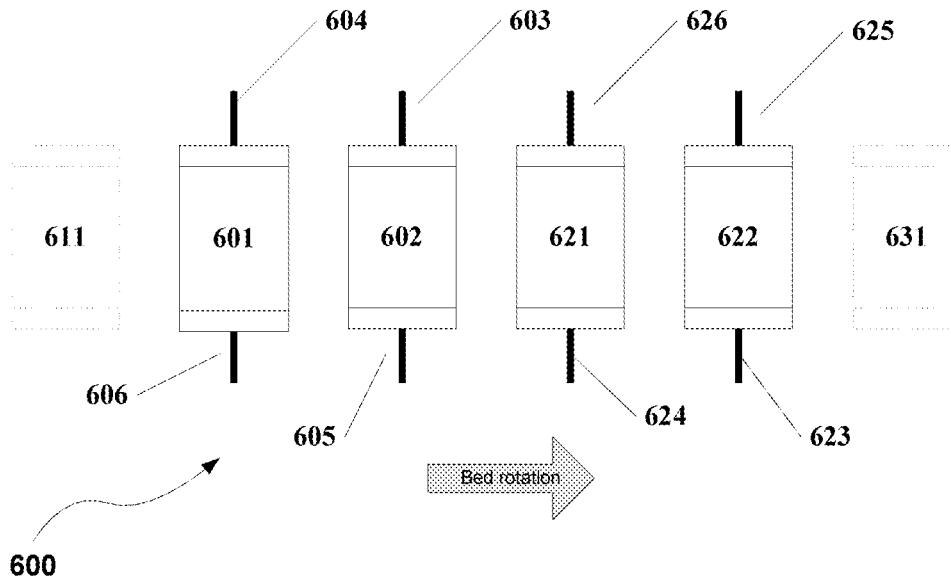

FIG. 6

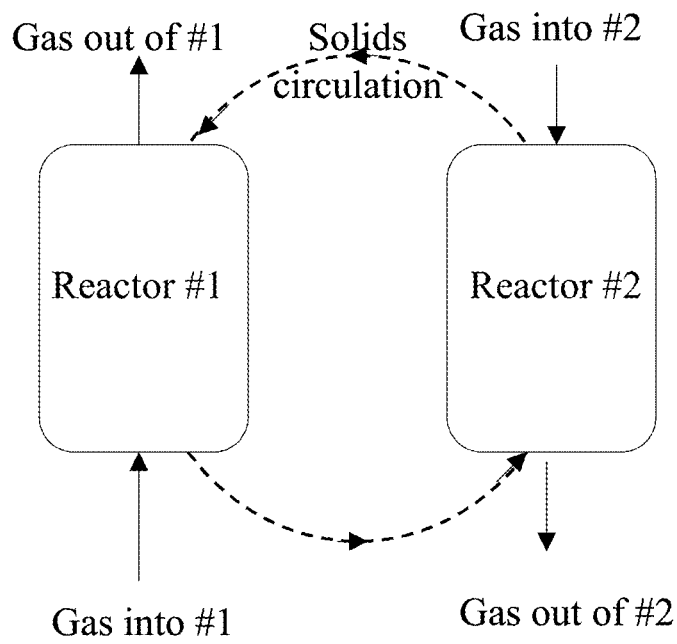

FIG. 7

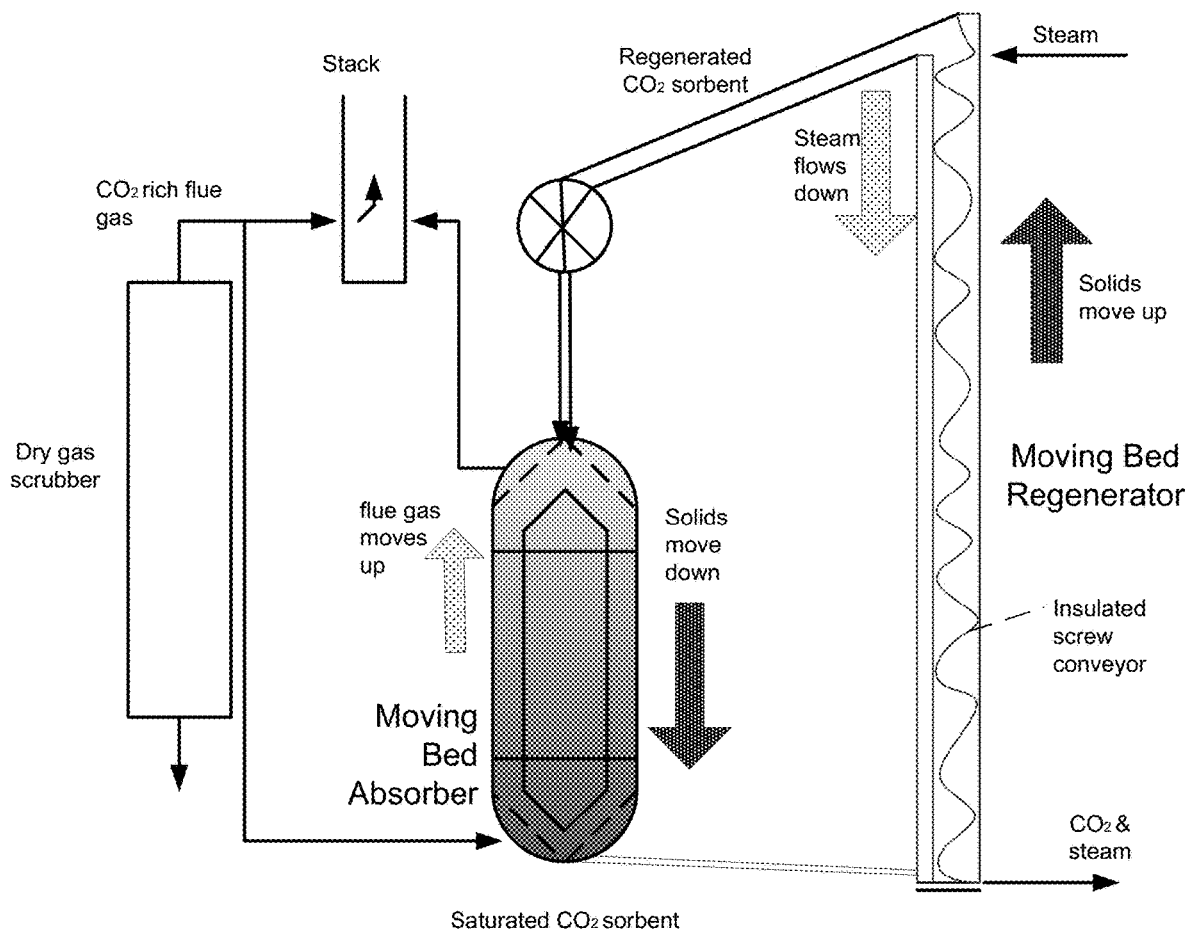

FIG. 8

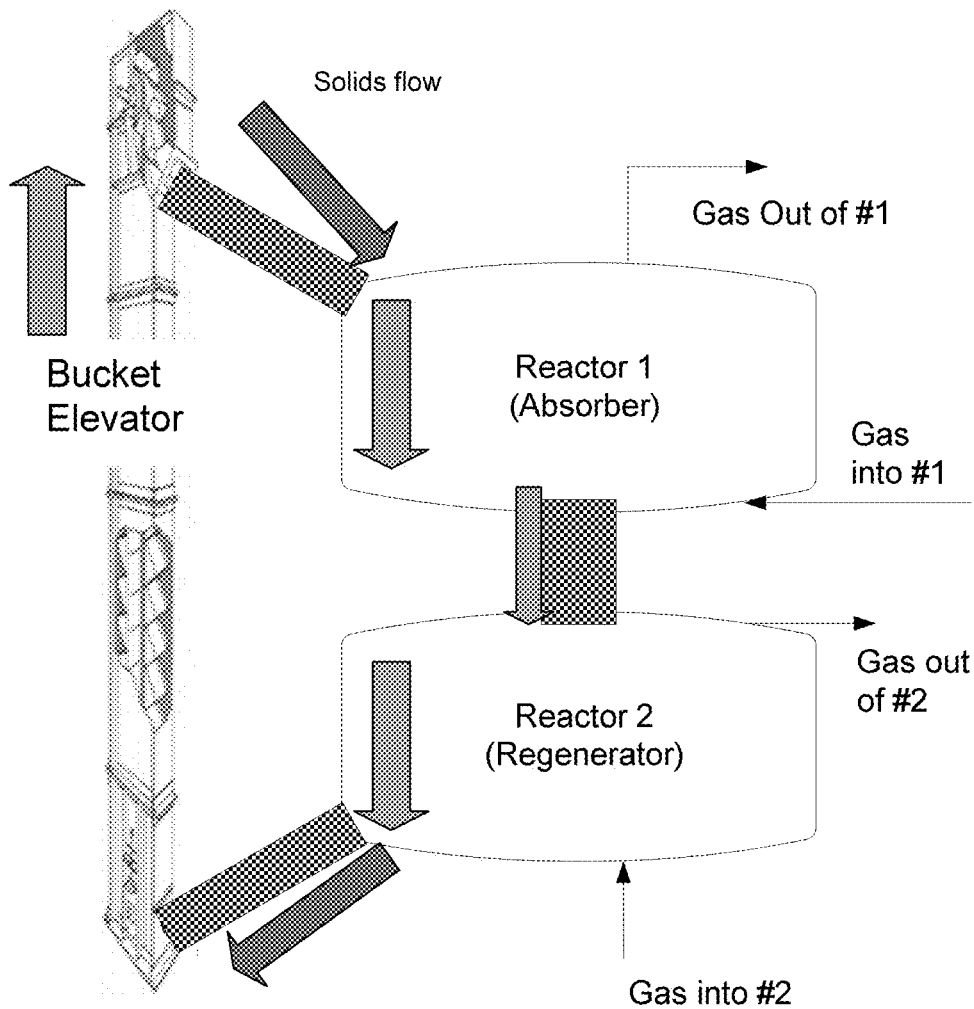

FIG. 9

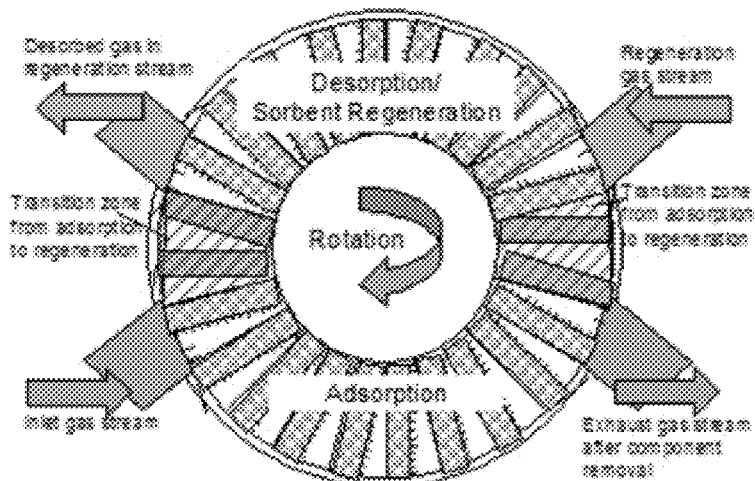

FIG. 10

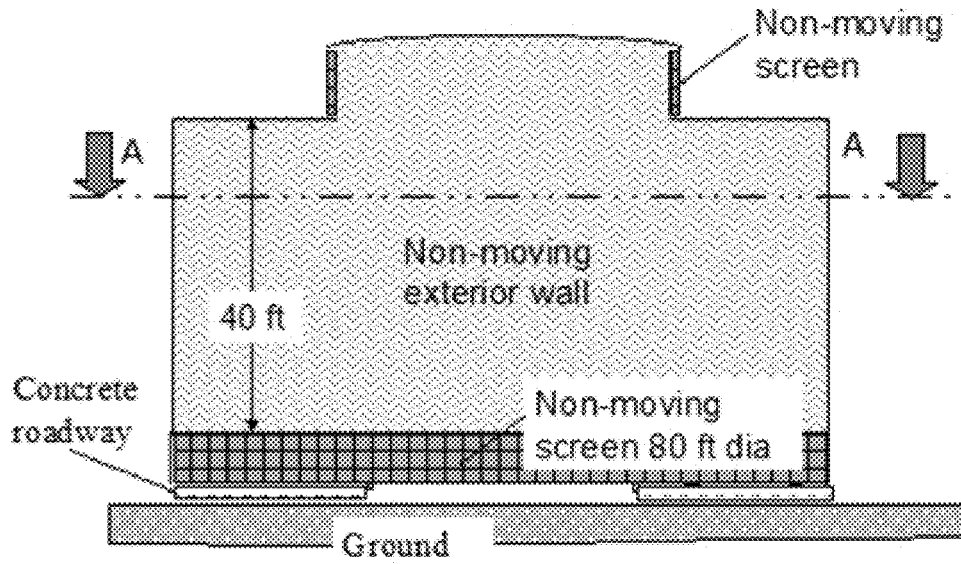

FIG. 11

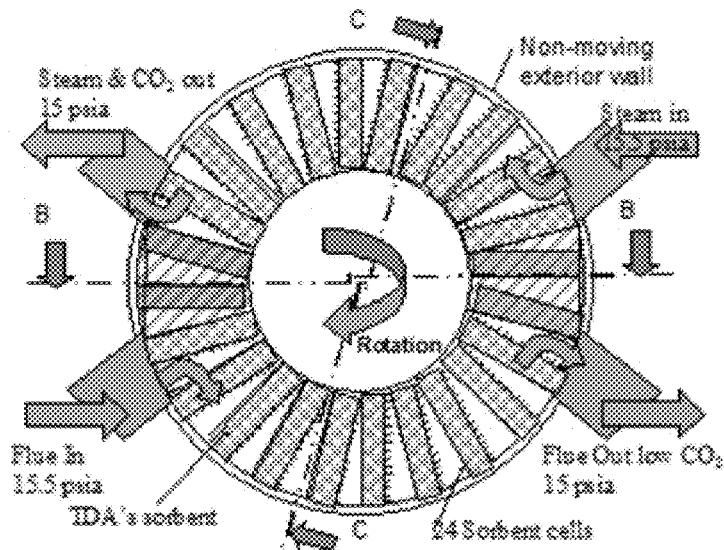

FIG. 12

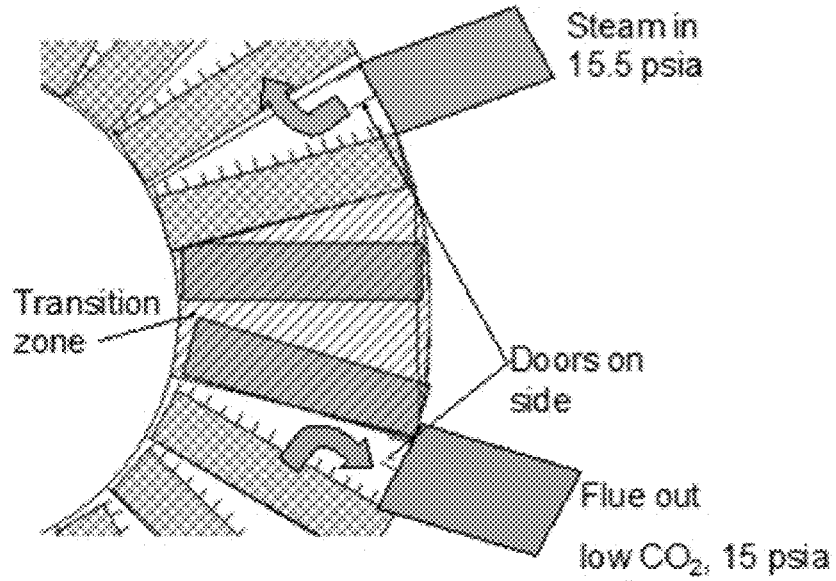

FIG. 13

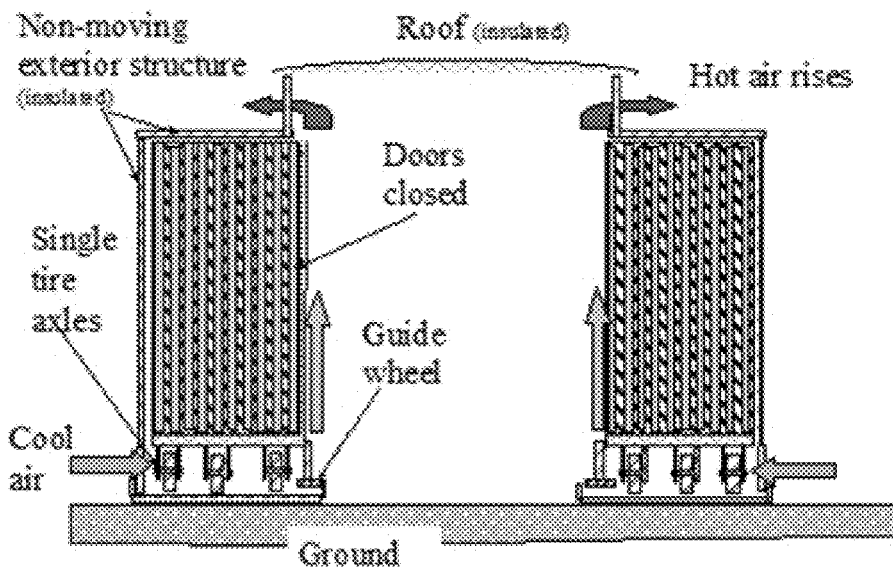

FIG. 14

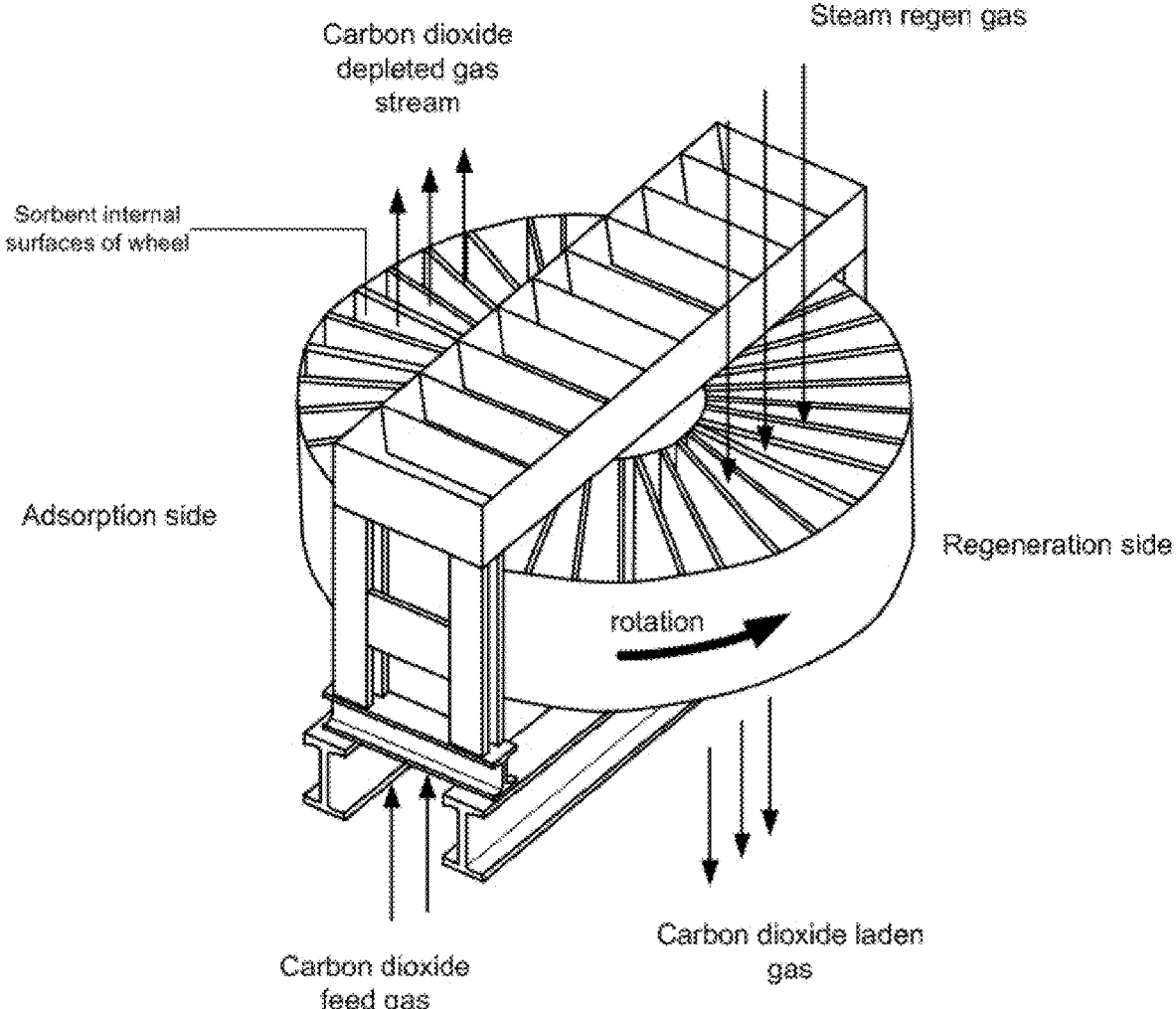

FIG. 15

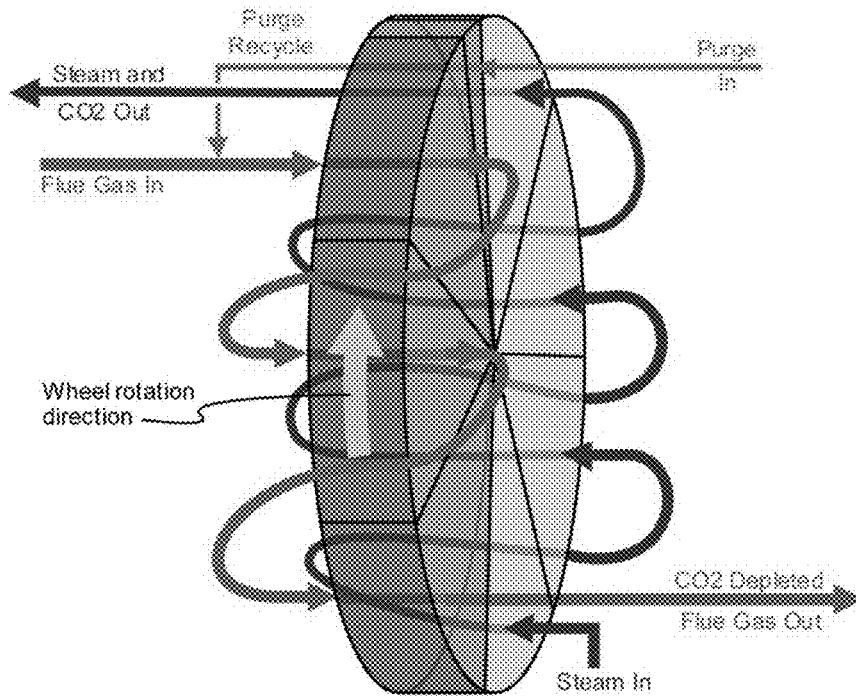

FIG. 16

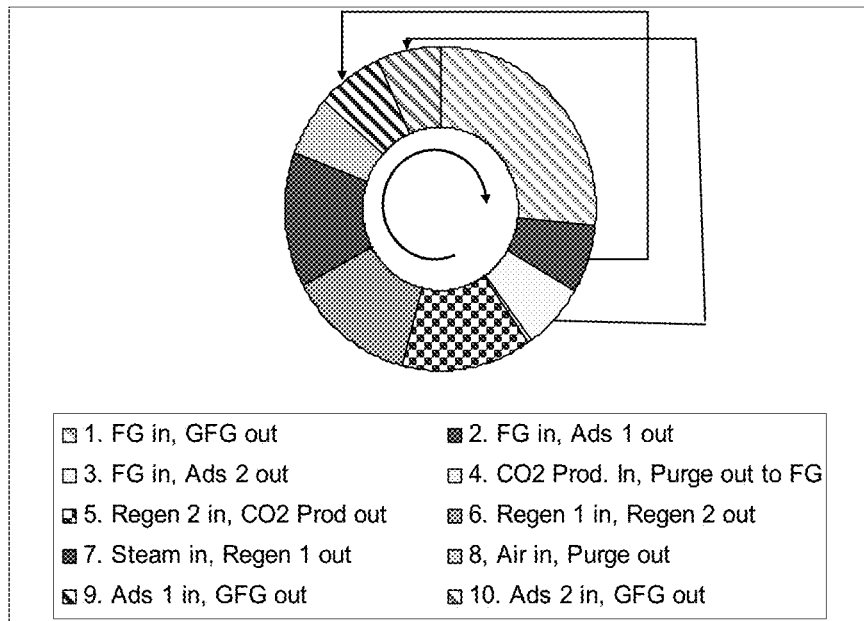

FIG. 17

Individual Sorbent Module

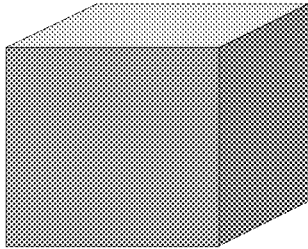

FIG. 18A

Inter-bed Spacer / Flow Channels

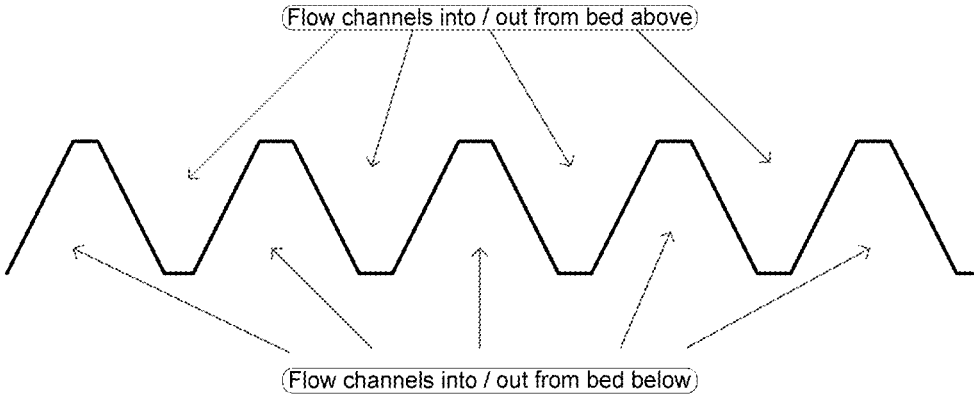

FIG. 18B

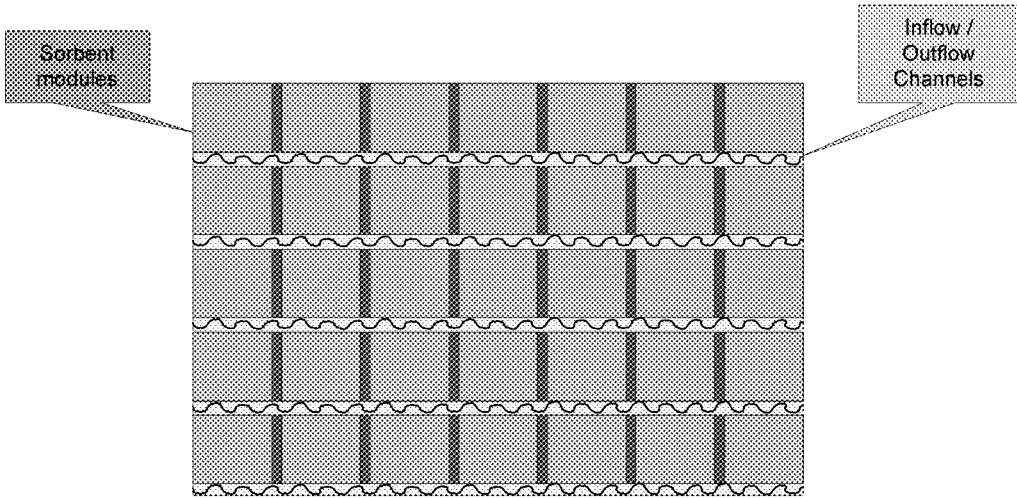

FIG. 19A

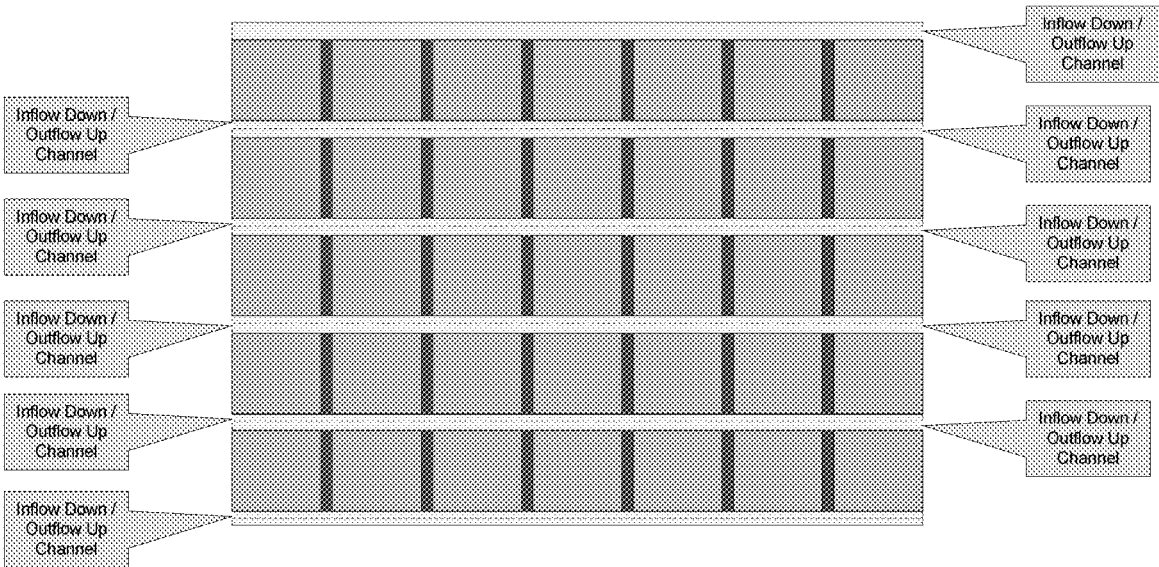

FIG. 19B

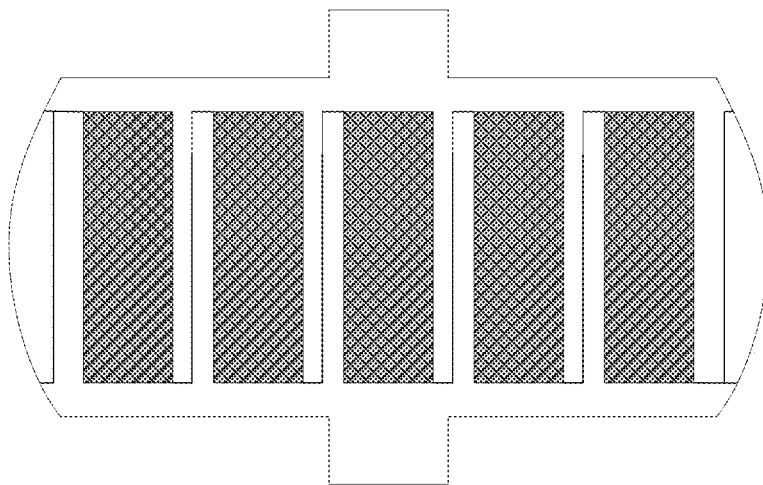

FIG. 20

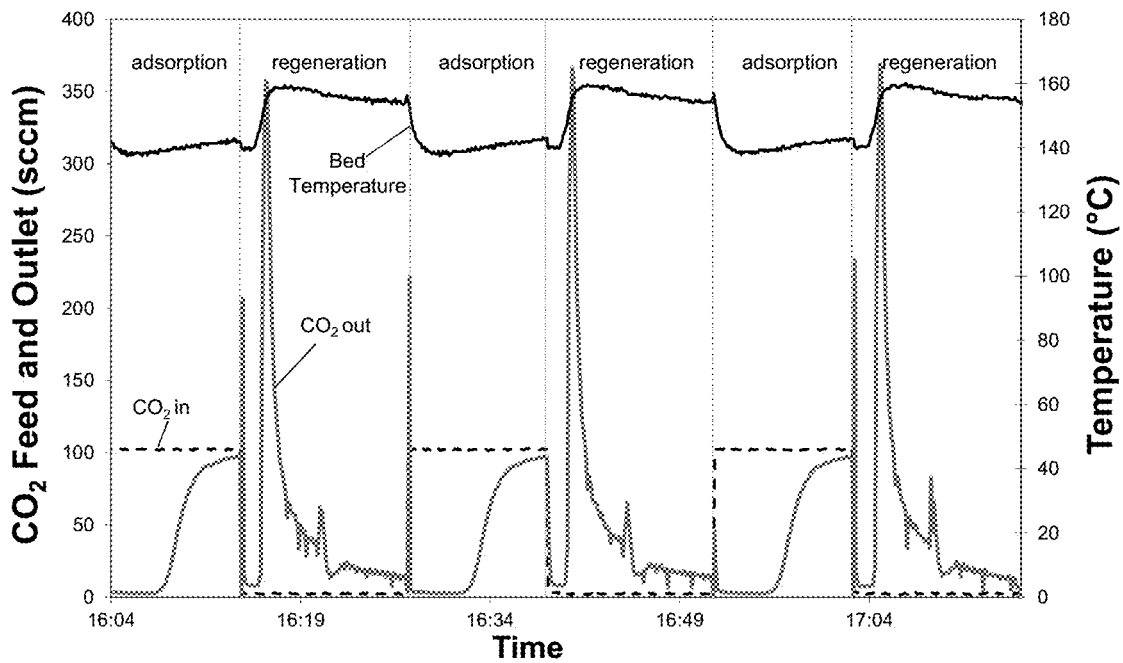

FIG. 21.

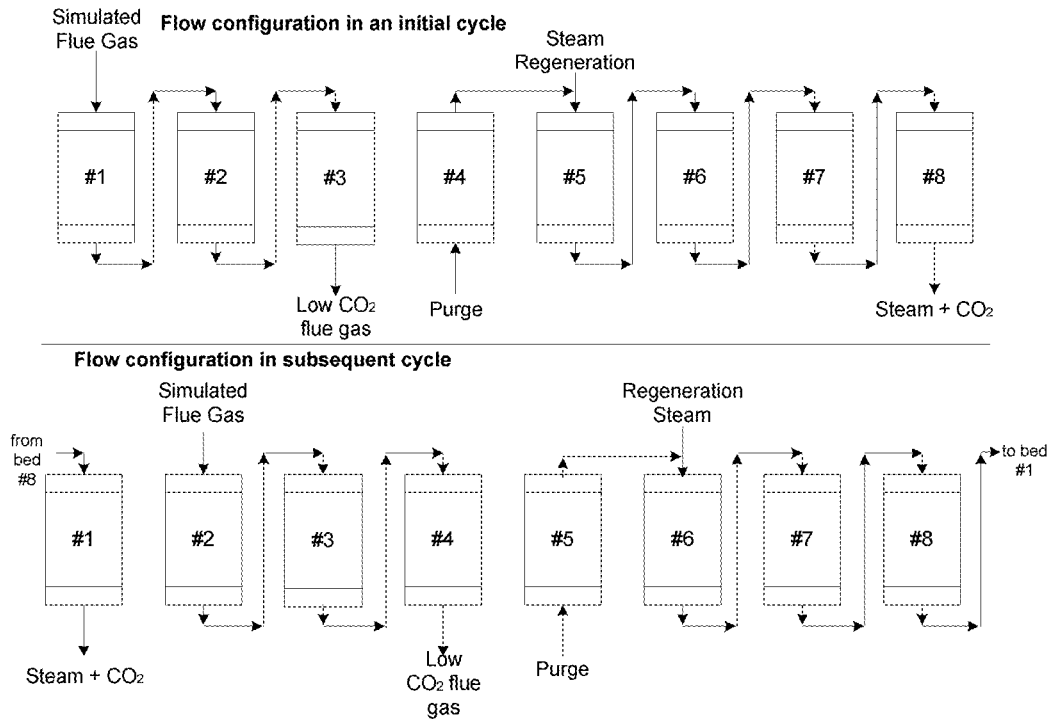

FIG. 22

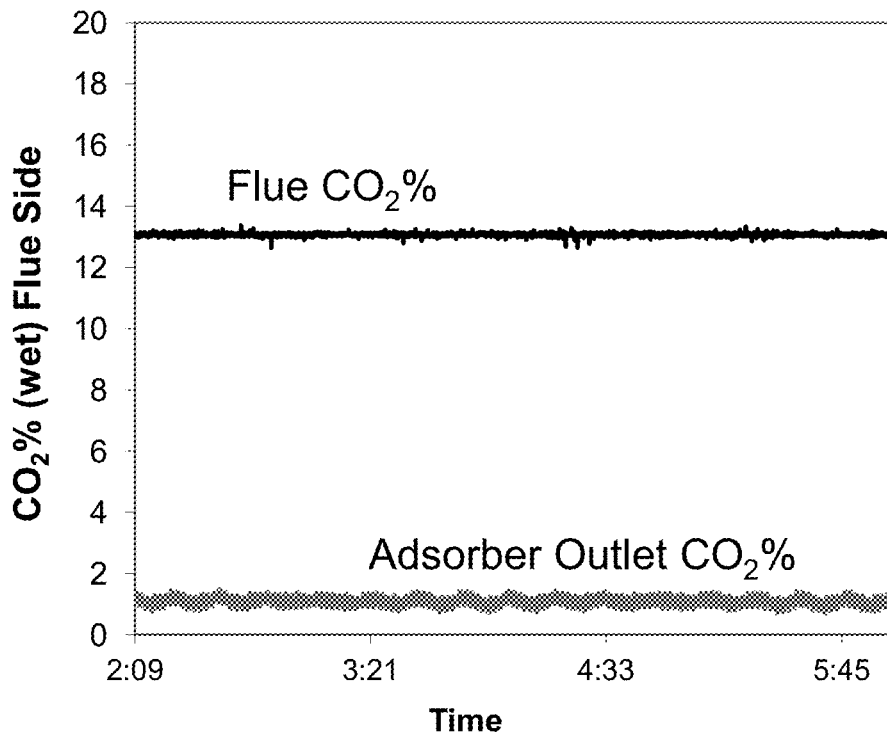

FIG. 23

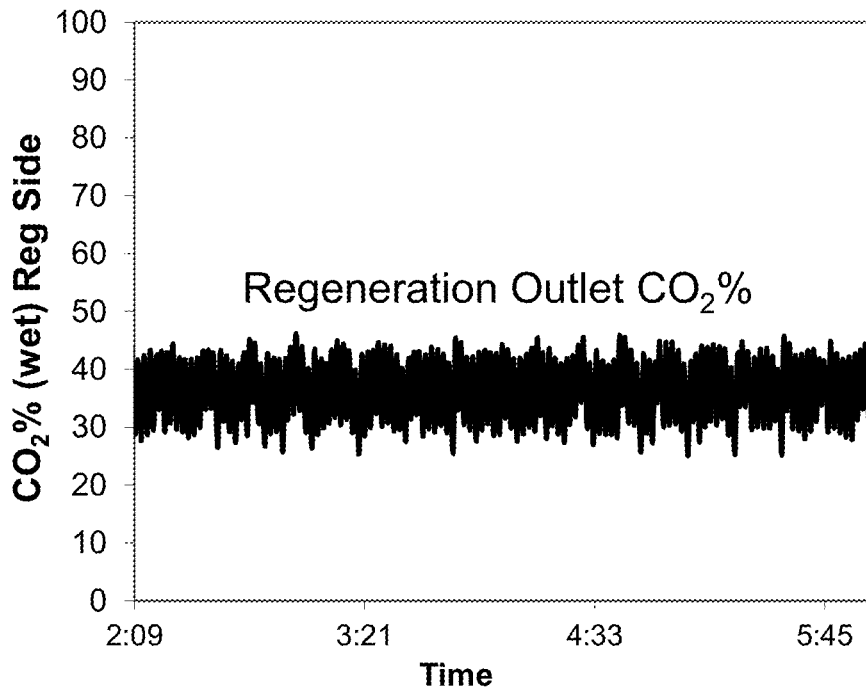

FIG. 24

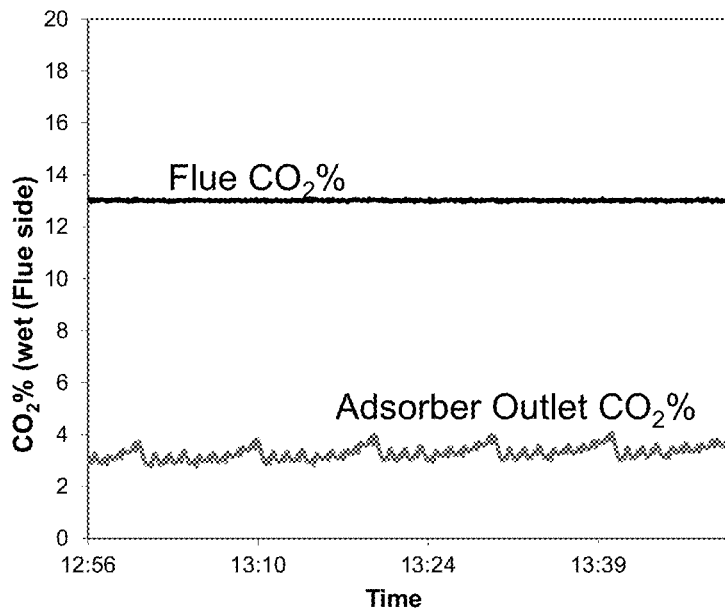

FIG. 25

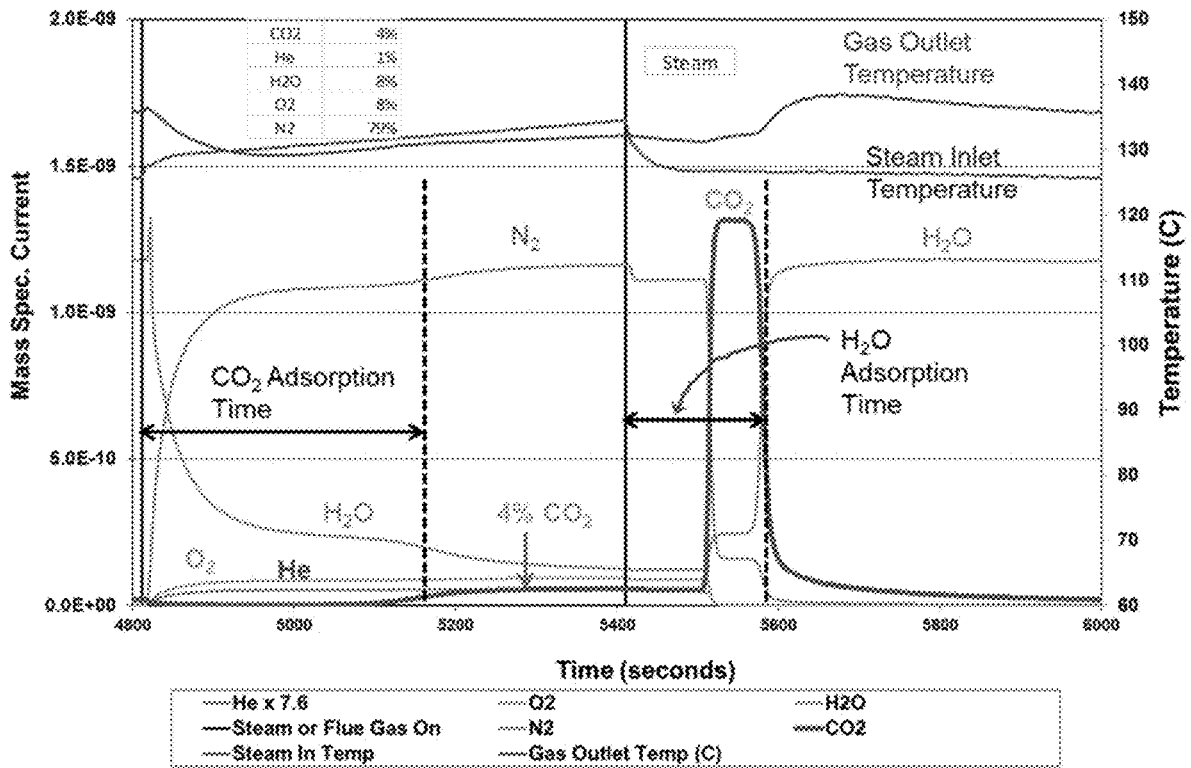

FIG. 26

Properties of sorbent

Bulk density = 0.95 g/cc
 Crush strength = 6.3 LB_f/mm large batch
 Shape = cylinders made by extrusion
 Pore volume = 0.19 cc/g
 Surface area = 59 m²/g
 Active component = sodium 9% (wt)

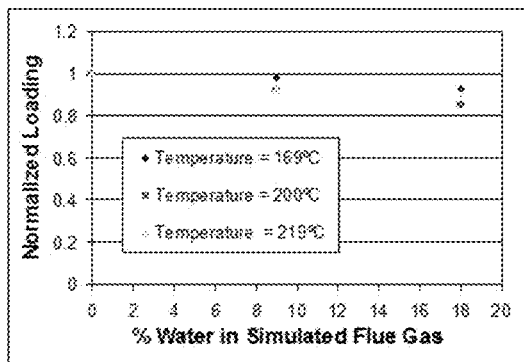

FIG. 27

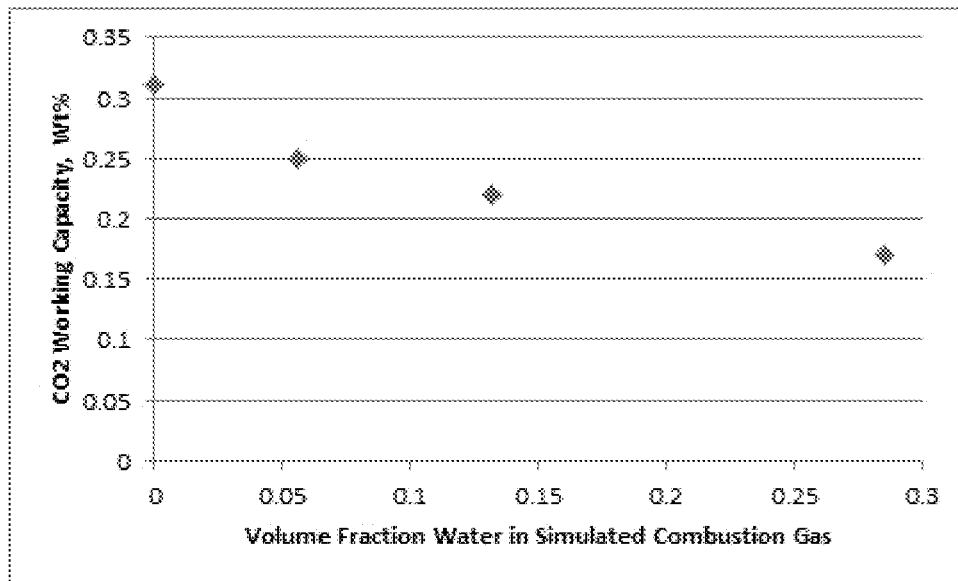

FIG. 28

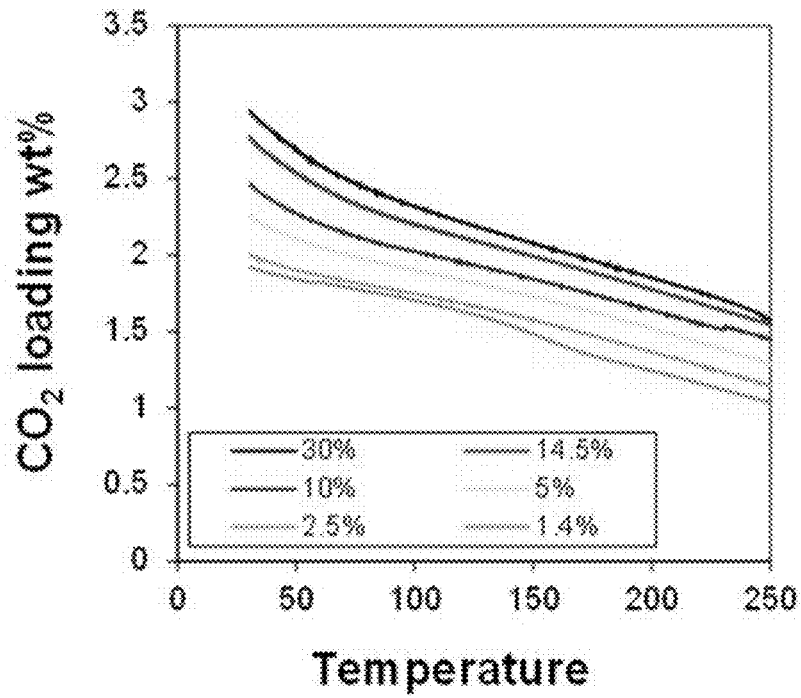

FIG. 29A

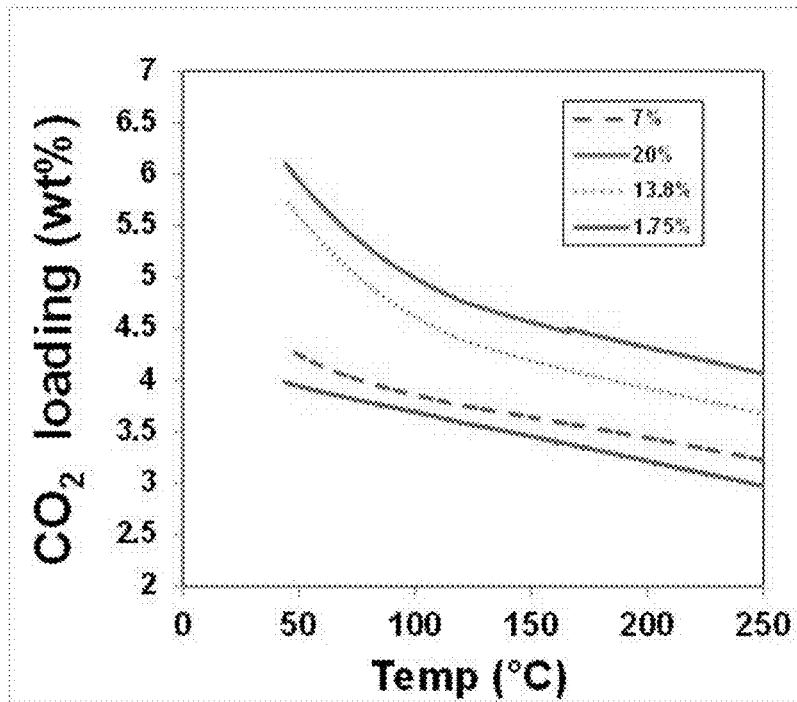

FIG. 29B

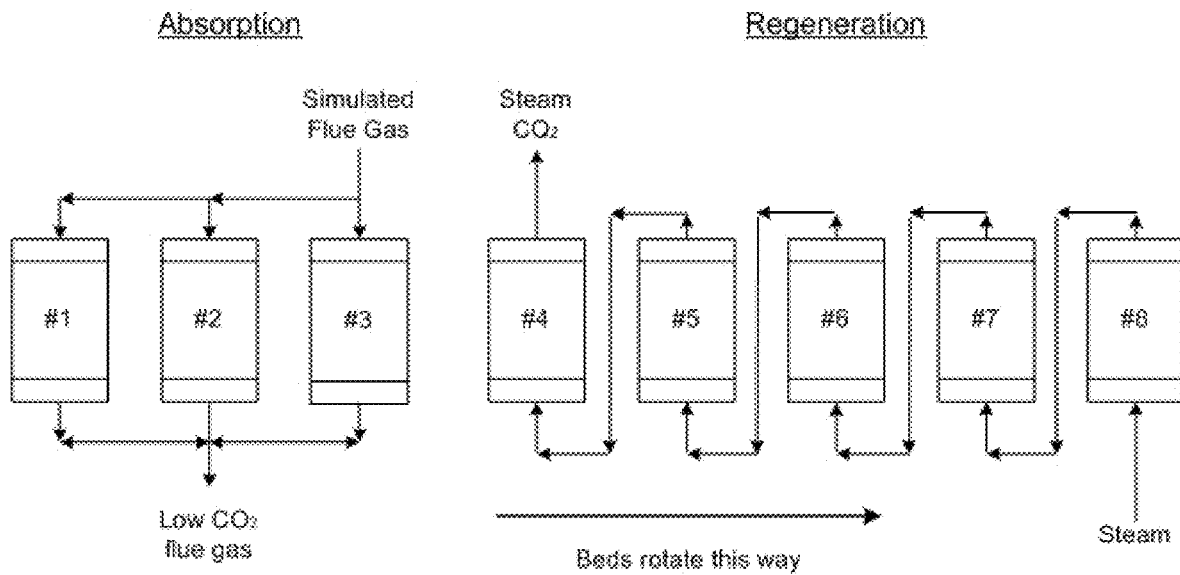

FIG. 30

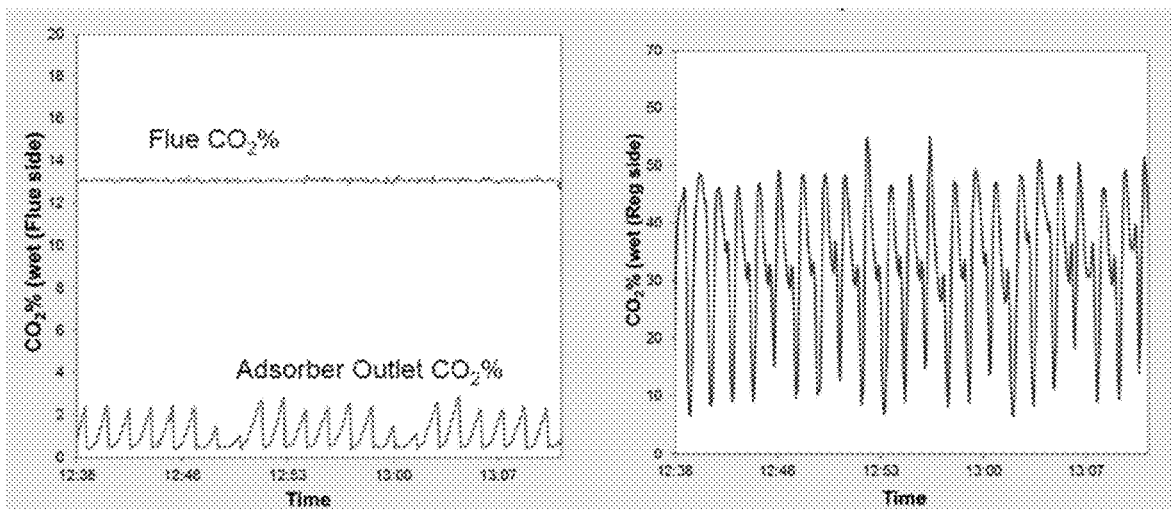

FIG. 31

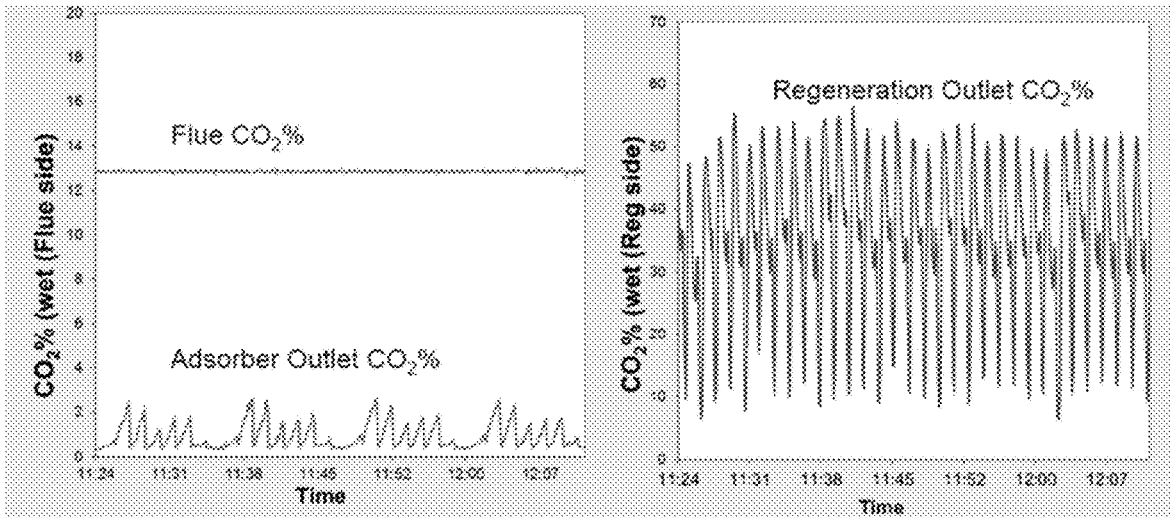

FIG. 32

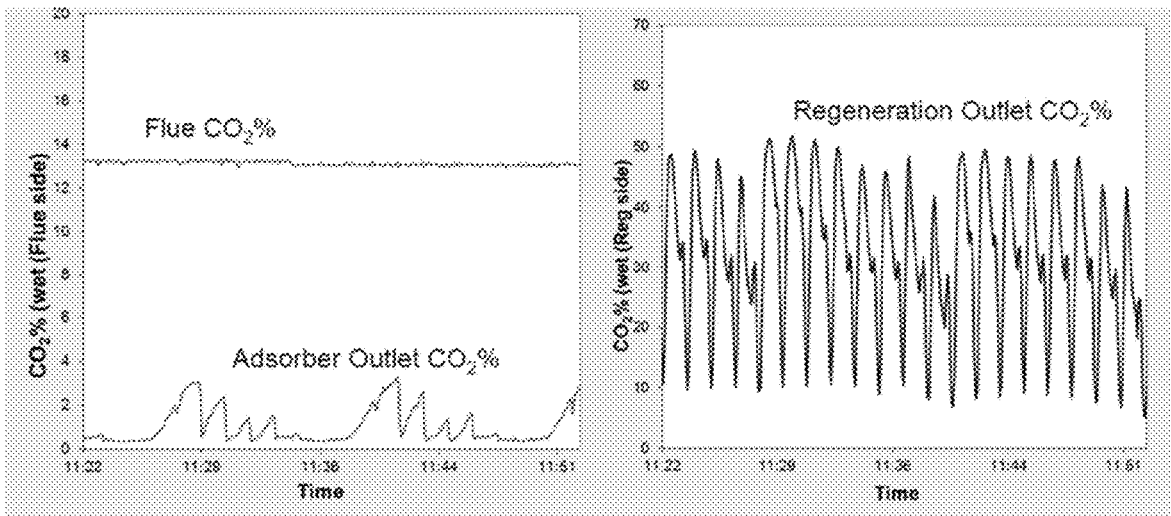

FIG. 33

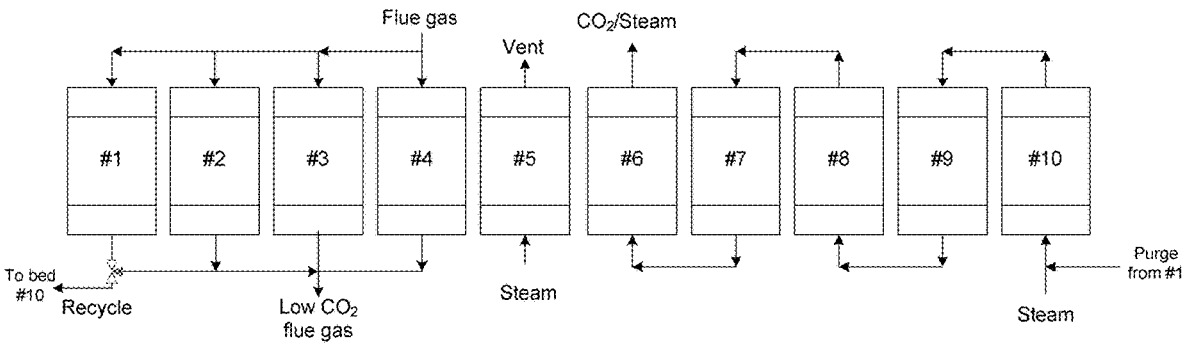

FIG. 34A

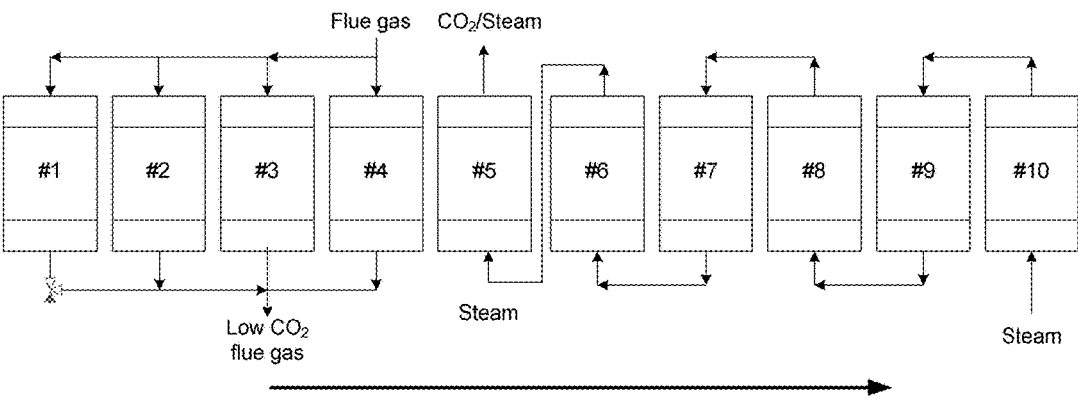

FIG. 34B

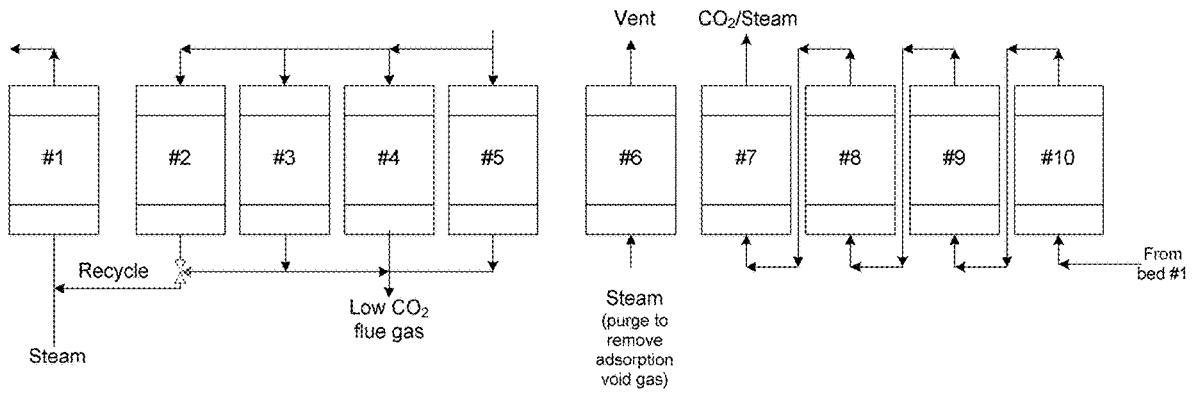

FIG. 34C

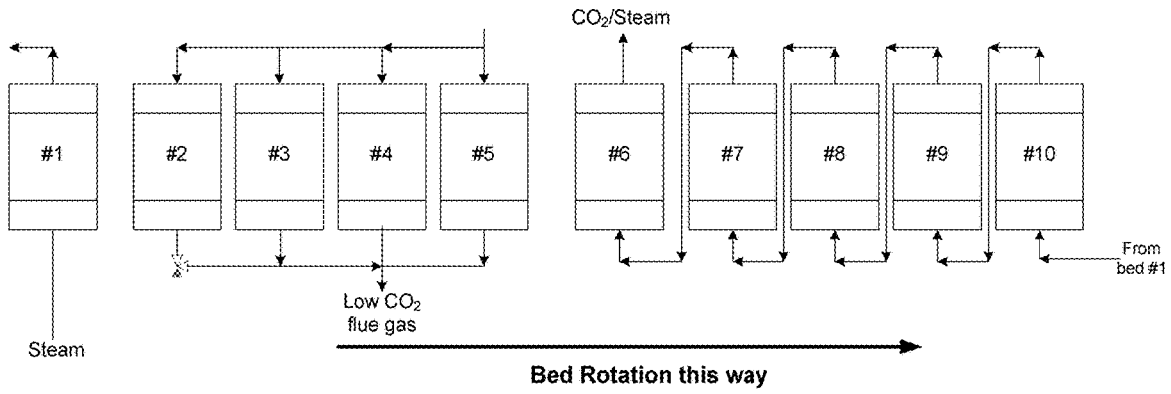

FIG. 34D

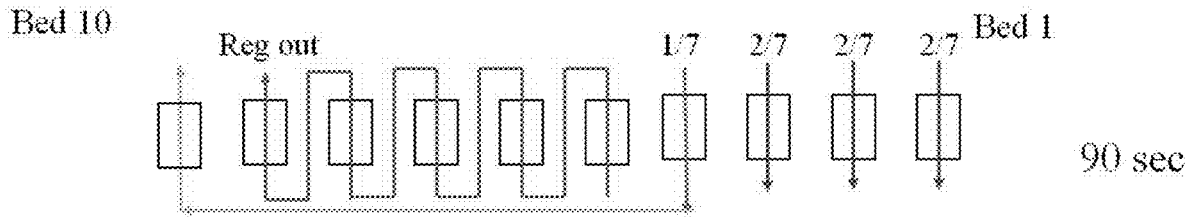

FIG. 35A

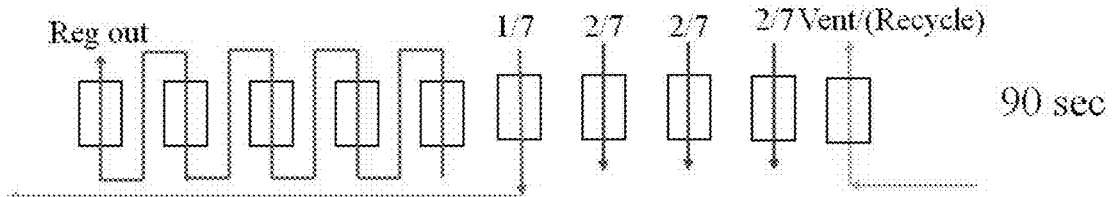

FIG. 35B

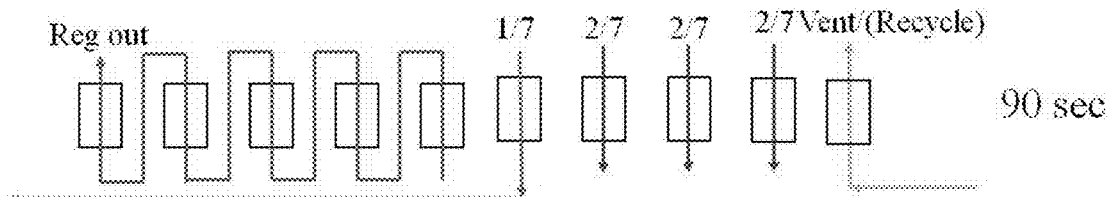

FIG. 35C

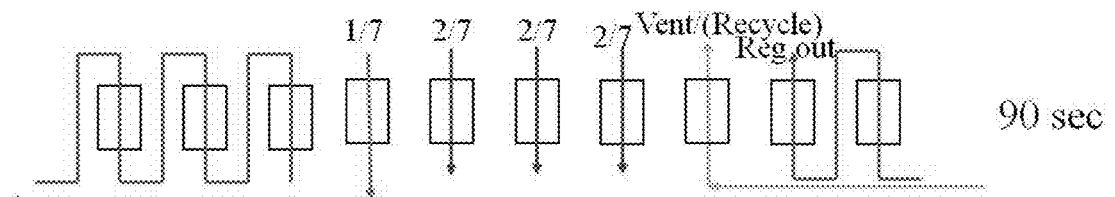

FIG. 35D

**COMPOSITIONS FOR CARBON DIOXIDE
SEPARATION USING STEAM
REGENERATION, AND METHOD FOR
PREPARING SAME**

CROSS-REFERENCE TO RELATED
APPLICATIONS

[0001] This application is a continuation of U.S. patent application Ser. No. 14/325,654, filed Jul. 8, 2014, now allowed, entitled, “Compositions for Carbon Dioxide Separation Using Steam Regeneration, and Method for Preparing Same,” which claims the benefit, under 35 U.S.C. § 119(e), of U.S. Provisional Patent Application No. 61/843,759, filed Jul. 8, 2013, entitled “Compositions for Carbon Dioxide Separation Using Steam Regeneration, and Method for Preparing Same,” the entire contents and substance of which are hereby incorporated by reference as if fully set forth below.

STATEMENT OF FEDERALLY SPONSORED
RESEARCH

[0002] Portions of this disclosure were made with Government support under Grant Number DE-NT0005497, awarded by The Department of Energy. The Government may have certain rights in the disclosure.

TECHNICAL FIELD

[0003] The various embodiments of the disclosure relate generally to processes, methods, and systems for the separation of CO₂ from mixed gas streams using an essentially isothermal cyclic adsorption process. It is particularly useful for CO₂ capture from combustion gases and can be used for other applications such as natural gas purification for example.

BACKGROUND

[0004] Fossil fuels currently supply the majority of the world’s energy needs and their combustion is the largest source of anthropogenic carbon dioxide emissions. Carbon dioxide is a greenhouse gas and is believed to contribute to global climate change. Concern over global climate warming has led to interest in capturing CO₂ emissions from the combustion of fossil fuels. CO₂ can be removed from combustion flue gas streams by varying methods.

[0005] Combustion gases vary in composition depending on the fuel and the conditions of combustion. The combustion gases can be produced in furnaces and in gas turbines, including the combustion gases produced in the generation of electric power. The fuels used are predominantly coal and natural gas. Coal is burned in furnaces, while natural gas is burned both in furnaces and in gas turbines, but in electric power generation natural gas is mainly burned in gas turbines.

[0006] The quantities of combustion gas produced in electric power generation are very large because of the scale of furnaces and turbines used. One measure of the scale of these operations is the amount of CO₂ produced in a typical 500 Megawatt power plant. For coal fired power generation, the rate of CO₂ production is on the order of 100 kilograms per second; for gas fired power production it is more like 50 kilograms per second.

[0007] The challenge for flue gas CO₂ capture is to do it efficiently to minimize the cost. All post-combustion CO₂

capture technologies suffer from the disadvantage that the CO₂ in the flue gas is present at low pressure (just about 1 atm) and in low concentrations (3 to 15%). A large amount of energy is needed to separate the CO₂. For 90% recovery of 10% CO₂ in a flue gas at 1 atm, the CO₂ must be brought from 0.1 atm to 1 atm, and then further compressed to a delivery pressure of 150 atm. Analyses conducted at NETL shows that CO₂ capture and compression using a conventional absorption process raises the cost of electricity from a newly built supercritical PC power plant by 86%, from 64 cents/kWh to 118.8 cents/kWh (Julianne M. Klara, DOE/NETL-2007/1281, Revision 1, August 2007, Exhibit 4-48 LCOE for PC Cases). Aqueous amines are considered a state-of-the-art technology for CO₂ capture for PC power plants, but have a cost of \$68/ton of CO₂ avoided (Klara 2007, DOE/NETL-2007/1282). Developing methods that minimize the amount of energy and other costs will be necessary if CO₂ removal from flue gas is to be economical.

[0008] Methods for the removal of CO₂ from gas streams, include adsorption with a solvent, adsorption with a sorbent, membrane separation, and cryogenic fractionation and combinations thereof. In absorption/adsorption processes to capture CO₂, the energy needed to regenerate the sorbent or solvent is a large cost element.

[0009] The heat of adsorption is generally lower than the heat of absorption. This could make use of physical adsorbent for CO₂ capture attractive because it has a lower energy requirement for the desorption reaction to release the CO₂. A physical adsorbent can be used for CO₂ capture. Using molecular sieves/zeolites and activated carbon, this approach for CO₂ capture has been researched by Inui 1988 [Inui, T., Okugawa, Y. and Yasuda, M. (1988), Relationship between properties of various zeolites and their CO₂ adsorption behaviours in pressure swing adsorption operation, *Industrial & Engineering Chemistry Research*, 27, 1103], Chue 1995 [Chue, K. T., Kim, J. N., Yoo, Y. J., Cho, S. H. and Yang, R. T. (1995), Comparison of activated carbon and zeolite 13x for CO₂ recovery from flue gas by pressure swing adsorption, *Industrial & Engineering Chemistry Research*, 34 (2), 591-598], Siriwardane 2001 [Siriwardane, R. V., Shen, M., Fisher, E., and Poston, J. A., (2001) “Adsorption of CO₂ on Molecular Sieves and Activated Carbon,” *Energy and Fuels*, Vol. 15, pp. 279-284, 2001], Siriwardane 2005a [Siriwardane, R. V., (2005a) “Solid Sorbents for Removal of Carbon Dioxide from Low Temperature Gas Streams”, U.S. Pat. No. 6,908,497 B1, Jun. 21, 2005], Siriwardane 2005b [Siriwardane, R. V., Shen, M., and Fisher, E., (2005b) “Adsorption of CO₂ on Zeolites at Moderate Temperatures,” *Energy and Fuels*, Vol. 19 No. 3, p. 1153, 2005], Muñoz et al (2006) [Muñoz, Emilio, Eva Diaz, Salvador Ordóñez, and Aurelio Vega “Adsorption of Carbon Dioxide on Alkali Metal Exchanged Zeolites”, *Gingichashvili Sarah* (May 19, 2008)—<http://thefutureofthings.com/news/1183/co2-absorption-made-easier.html>], Halmann and Steinberg (1999) [Halmann, MM and M Steinberg, (1999) *Greenhouse Gas—Carbon Dioxide Mitigation: Science and Technology*. Lewis Publishers, Boca Raton, Fla.] and Lee (2005) [Lee, Sunggyu (2005) *Encyclopedia of Chemical Processing Vol 1*. CRC Press].

[0010] Many physical adsorbent separation systems use pressure swing absorption (PSA) for regeneration. PSA can be used to regenerate CO₂ adsorbents. It is used in environmental control applications to maintain CO₂ level (Lee 2005

[Lee, Sunggyu (2005) Encyclopedia of Chemical Processing Vol 1. CRC Press]). Also, PSA is used for removal of CO₂ down to very low levels in gas purification (U.S. Pat. No. 5,656,064). Applying PSA to atmospheric flue gas separation would have high energy consumption requirements (due the requirement to pull a hard vacuum when removing CO₂ from a flue gas) and capital costs because of the large pressure ratios required to enable complete desorption of the CO₂.

[0011] Temperature swing absorption is another well-established regeneration method. This has been applied to adsorbent regeneration by Lee (2005) [Lee, Sunggyu (2005) Encyclopedia of Chemical Processing Vol 1. CRC Press].

[0012] Such separation processes are also commonly applied for CO₂ separations of gases from non-combustion gas streams, e.g. natural gas purification, re-breathers, contained environment CO₂ concentration control and others.

BRIEF SUMMARY

[0013] The various embodiments of the disclosure relate generally to processes, methods, systems, and compositions for adsorbing CO₂ from a gas stream on a sorbent, and regenerating the sorbent by desorbing the CO₂.

[0014] An embodiment of the disclosure can be a sorbent composed of a support and a metal compound selected from the group consisting of alkali and alkaline earth. The sorbent of can consist essentially of the support and the metal compound, and any associated counterions, or can consists of the support and the metal compound, and any associated counterions. In an embodiment, the metal compound is at least 5 wt % of the sorbent, or at least 7 wt % of the sorbent, or at least 10 wt % of the sorbent. The support can include alumina, titania, zirconia, silica, clay, carbon, and mixtures thereof, or can be alumina. The support can have a surface area of at least about 100 m²/g, or at least about 200 m²/g. In an embodiment, the metal compound can be Li, Na, K, Rb, Cs, Be, Mg, Ca, Sr, or Ba, or a combination thereof, or can be Li, Na, K, Mg, or Ca, or a combination thereof, or can be Na or K.

[0015] An embodiment of the disclosure can be a CO₂ adsorption sorbent including a support and a metal compound selected from the group consisting of alkali and alkaline earth, as discussed above. In an embodiment, the metal compound can be at least 5 wt % of the sorbent, or at least 7 wt % of the sorbent, or at least 10 wt % of the sorbent. In an embodiment, the metal compound can be Li, Na, K, Rb, Cs, Be, Mg, Ca, Sr, or Ba, or a combination thereof, or can be Li, Na, K, Mg, or Ca, or a combination thereof, or can be Na or K.

[0016] An embodiment of the disclosure can be a CO₂/H₂O equilibrium sorbent, including a metal compound and a support, wherein the sorbent has a greater capacity for carbon dioxide than the support, and the sorbent has a greater capacity for water than the support. The ratio of carbon dioxide and water on the support can vary with the relative concentration of the two sorbates in the environment above the sorbent. In an embodiment, the sorbent can adsorb CO₂ in the presence of less than 35% water vapor. The sorbent can desorb CO₂ in the presence of greater than 60% water vapor.

[0017] Another embodiment of the disclosure can be adsorption-desorption sorbent comprising a metal compound and a support, wherein the sorbent has a carbon dioxide capacity of at least about 0.5 wt %, a water capacity

of at least about 1 wt %, and a water/carbon dioxide selectivity that varies with the relative concentration of the two sorbates in the environment above the sorbent. The sorbent can have a carbon dioxide capacity of at least about 0.7 wt %, or of at least about 1.0 wt %. The sorbent can have a water capacity of at least about 1.5 wt %, or of at least about 2 wt %.

[0018] An embodiment of the disclosure can be a sorbent comprising a metal compound and a support, wherein the sorbent will adsorb carbon dioxide from a wet atmosphere. The sorbent can adsorb the carbon dioxide from the wet atmosphere having up to 35 wt % water, or can adsorb the carbon dioxide and desorb water in a wet atmosphere having up to 35% water or less. The sorbent can adsorb carbon dioxide after the sorbent has been saturated with water at a partial pressure of 1 bar. In an embodiment, the sorbent previously loaded with carbon dioxide can also desorb carbon dioxide from the sorbent in an atmosphere that is greater than 35% water, and can desorb carbon dioxide from the sorbent previously loaded with carbon dioxide at a partial pressure of 0.02 to 1.0 bar.

[0019] An embodiment of the disclosure can be a carbon dioxide-water equilibrium adsorption surface, comprising metal compound adhered to the surface of a support, wherein the surface adsorbs carbon dioxide and desorbs water in a CO₂-water atmosphere having less than 35 wt % water, and desorbs carbon dioxide and adsorbs water in a CO₂-water atmosphere having greater than 60 wt % water.

[0020] An embodiment of the disclosure can be a CO₂ adsorption sorbent comprising a support; a metal compound comprising Li, Na, K, Rb, Cs, Be, Mg, Ca, Sr, or Ba, or a combination thereof; and adsorbed carbon dioxide, wherein the metal compound is at least 5 wt % of the sorbent, and the adsorbed carbon dioxide is at least 0.7 wt %. In an embodiment, the metal compound is at least about 7 wt % of the sorbent, or at least about 1.0 wt % of the sorbent. In an embodiment, the the adsorbed carbon dioxide can be at least about 1.0 wt %, or at least about 1.5 wt %.

[0021] An embodiment of the disclosure can include a method of making a sorbent comprising treating a support with a solution consisting essentially of a metal complex and a solvent, and drying the sorbent. The method can include the metal complex which is an organometallic complex. The metal complex can be an acetate or citrate complex with alkali or alkaline metal, or can be an acetate or citrate complex with Na or K. In an embodiment, the, when the support has a known pore volume, the support is treated with an approximately equal volume of the metal solution. In an embodiment, the method can include the further the step of calcining the sorbent at a temperature of at least about 400° C., or calcining the sorbent at a temperature of at least about 400° C. in an air flow of at least about 3 volume/volume solid/minute.

[0022] Another embodiment of the disclosure can be a A method of making a sorbent comprising preparing pellets of a support by mixing the support in water, drying, and firing at least at about 300° C., mixing the pellets in an aqueous solution comprising water and a metal complex to prepare a pre-sorbent, drying the pre-sorbent at a temperature of at least 120° C. The method can include the further step of calcining the dried pre-sorbent at a temperature of at least about 400° C.

[0023] Another embodiment of the disclosure can be a method of making a sorbent comprising admixing a support

in an aqueous slurry containing the alkali or alkaline metal complex and forming the slurry into an extrudate or pellet, and calcining to at least 300° C., and an additional alkali or alkaline metal species can be added to the formed alkalinized support pellet by impregnation from an aqueous solution.

BRIEF DESCRIPTION OF THE DRAWINGS

[0024] FIG. 1 illustrates a graphical representation of a cyclic displacement process in accordance with an exemplary embodiment of the disclosure.

[0025] FIG. 2 illustrates a representation of a CO₂ separation system in accordance with an exemplary embodiment of the disclosure.

[0026] FIGS. 3A through 3F illustrate a five-bed simulated moving bed system and associated valve positions, in accordance with an exemplary embodiment of the disclosure.

[0027] FIGS. 4A through 4F illustrate another five-bed simulated moving bed system and associated valve positions, in accordance with an exemplary embodiment of the disclosure.

[0028] FIGS. 5A and 5B illustrate an eight-bed simulated moving bed system, in accordance with an exemplary embodiment of the disclosure.

[0029] FIG. 6 illustrates a simulated moving bed system, in accordance with an exemplary embodiment of the disclosure.

[0030] FIG. 7 illustrates a counter-flow moving bed design, in accordance with an exemplary embodiment of the disclosure.

[0031] FIG. 8 illustrates another moving bed design, in accordance with an exemplary embodiment of the disclosure.

[0032] FIG. 9 illustrates a stacked moving bed design with a bucket elevator, in accordance with an exemplary embodiment of the disclosure.

[0033] FIG. 10 illustrates a counter-flow rotary wheel bed design, in accordance with an exemplary embodiment of the disclosure.

[0034] FIG. 11 illustrates the external housing and structure of the rotary wheel design of FIG. 12, in accordance with an exemplary embodiment of the disclosure.

[0035] FIG. 12 illustrates a nonlimiting twenty four sorbent cell rotary wheel design, along the A-A line of FIG. 11, in accordance with an exemplary embodiment of the disclosure.

[0036] FIG. 13 illustrates the transition zone between adsorption and regeneration in the rotary wheel of FIG. 12, in accordance with an exemplary embodiment of the disclosure.

[0037] FIG. 14 illustrates interior vertical cross-section of the rotary wheel of FIG. 12, along the B-B line, in accordance with an exemplary embodiment of the disclosure.

[0038] FIG. 15 illustrates a sorbent cell rotary wheel design, in accordance with an exemplary embodiment of the disclosure.

[0039] FIG. 16 illustrates another sorbent cell rotary wheel design, in accordance with an exemplary embodiment of the disclosure.

[0040] FIG. 17 illustrates another sorbent cell rotary wheel design, in accordance with an exemplary embodiment of the disclosure.

[0041] FIGS. 18A and 18B illustrate an individual sorbent module and interbed spacers or flow channels, in accordance with an exemplary embodiment of the disclosure.

[0042] FIGS. 19A and 19B illustrate an inlet-outlet view and sideview of a layered beds system, in accordance with an exemplary embodiment of the disclosure.

[0043] FIG. 20 illustrates a segmented sorbent bed in accordance with an exemplary embodiment of the disclosure.

[0044] FIG. 21 illustrates a representation of a cyclic displacement process, in accordance with an exemplary embodiment of the disclosure.

[0045] FIG. 22 illustrates a multiple fixed bed test apparatus for continuous CO₂ capture, in accordance with an exemplary embodiment of the disclosure.

[0046] FIG. 23 illustrates inlet and outlet gas composition for a sorbent bed, in accordance with an exemplary embodiment of the disclosure.

[0047] FIG. 24 illustrates the percent CO₂ from regeneration of the sorbent bed of FIG. 22, in accordance with an exemplary embodiment of the disclosure.

[0048] FIG. 25 illustrates inlet and outlet gas composition for another sorbent bed, in accordance with an exemplary embodiment of the disclosure.

[0049] FIG. 26 illustrates a graphical display of results in a cyclic displacement system, in accordance with an exemplary embodiment of the disclosure.

[0050] FIGS. 27 and 28 illustrate the effect of water on CO₂ adsorption for two sorbents, in accordance with an exemplary embodiment of the disclosure.

[0051] FIGS. 29A and 29B illustrate the CO₂ loading of several sorbents, in accordance with an exemplary embodiment of the disclosure.

[0052] FIG. 30 illustrates an 8-bed simulated moving bed apparatus, in accordance with an exemplary embodiment of the disclosure.

[0053] FIGS. 31-33 illustrate gas flow results for a series of sorbents, in accordance with exemplary embodiments of the disclosure.

[0054] FIGS. 34A-34D illustrate a multiple bed simulated moving bed apparatus including optional recycle streams, in accordance with exemplary embodiments of the disclosure.

[0055] FIGS. 35A-35D illustrate a multiple bed simulated moving bed apparatus including optional steam saver, in accordance with exemplary embodiments of the disclosure.

DETAILED DESCRIPTION

[0056] Although preferred embodiments of the disclosure are explained in detail, it is to be understood that other embodiments are contemplated. Accordingly, it is not intended that the disclosure is limited in its scope to the details of construction and arrangement of components set forth in the following description or illustrated in the drawings. The disclosure is capable of other embodiments and of being practiced or carried out in various ways. Also, in describing the preferred embodiments, specific terminology will be resorted to for the sake of clarity.

[0057] It must also be noted that, as used in the specification and the appended claims, the singular forms “a,” “an” and “the” include plural referents unless the context clearly dictates otherwise.

[0058] Also, in describing the preferred embodiments, terminology will be resorted to for the sake of clarity. It is intended that each term contemplates its broadest meaning as understood by those skilled in the art and includes all technical equivalents which operate in a similar manner to accomplish a similar purpose.

[0059] Ranges can be expressed herein as from “about” or “approximately” one particular value and/or to “about” or “approximately” another particular value. When such a range is expressed, another embodiment includes from the one particular value and/or to the other particular value.

[0060] By “comprising” or “including” is meant that at least the named compound, element, particle, or method step is present in the composition or article or method, but does not exclude the presence of other compounds, materials, particles, method steps, even if the other such compounds, material, particles, method steps have the same function as what is named.

[0061] It is also to be understood that the mention of one or more method steps does not preclude the presence of additional method steps or intervening method steps between those steps expressly identified. Similarly, it is also to be understood that the mention of one or more components in a device or system does not preclude the presence of additional components or intervening components between those components expressly identified.

[0062] A sorbent-based process to separate carbon dioxide (CO₂) from a gas stream is disclosed. The sorbent can have alkali or alkaline earth elements dispersed on a solid. Examples of solids that can be used include alumina, carbon, resin, silica, other oxides or admixtures. The process employs gas-solids contactors in which the sorbent is alternately exposed to the feed gas and to steam wherein the gas and steam are essentially at the same temperature. In the steaming step the carbon dioxide adsorbed from the gas is released from the sorbent by a combination of concentration swing and desorptive displacement, thereby regenerating the sorbent for re-use. No external application or removal of heat is used, and the process operates at essentially constant pressure. The process is notably identifiable and distinguishable and beneficial as compared to pressure swing or partial pressure swing separation in that during the adsorption of CO₂ the bed temperature decreases below the average bed temperature as determined over the entire cycle and during CO₂ displacement/desorption the bed temperature increases above the average. The process is further distinguished and beneficial as compared to thermal swing separation in that no external heat is applied and the desorption gas, steam, is essentially isothermal with the feed gas. The gas-solids contactors may use moving solid sorbents, or solid sorbents contained in packed beds or in parallel-channel beds (monoliths). The packed bed or monoliths can be rotating or stationary. The water and energy from the regeneration steam can be recaptured after use and recycled back into the process.

[0063] The disclosure provides for a process for adsorbing and desorbing CO₂. The process can be notably identifiable and distinguishable and beneficial as compared to pressure swing or partial pressure swing separation in that, during the adsorption of CO₂, the bed temperature decreases below the average bed temperature as determined over the entire cycle and, during CO₂ displacement/desorption, the bed temperature increases above the average. The process can be further identifiable and distinguishable and beneficial as compared to thermal swing separation in that no external heat is applied and the desorption gas, steam, can be essentially isothermal with the feed gas. The gas-solids contactors can use moving solid sorbents or solid sorbents contained in packed beds or in parallel-channel beds (monoliths). The packed bed or monoliths can be rotating or stationary. To

permit continuous flow of inlet and outlet streams, multiple beds can be combined with appropriate valving to switch individual beds between adsorption and desorption. Such multiple bed arrangements can be operated to achieve counter-current staging. The water and energy from the regeneration steam can be recaptured after use and recycled back into the process. The process can be operated at temperatures greater than 100° C. enabling, for example CO₂ removal from flue gases exiting a heat recovery steam generator (HRSG) without extensive heating or cooling.

[0064] The disclosure further provides a regeneration process which uses contact with steam to remove the adsorbed gas from the sorbent. The regeneration mechanism can be by a combination of concentration swing and desorptive displacement of the adsorbed gas with steam. The disclosure can further relate to a method to recycle the steam and recover its energy through a multi-stage condenser/heat exchangers system. The advantage of this option is that it increases system efficiency.

[0065] The disclosure also relates to gas separations such as removal of CO₂ from a combustion flue gas or natural gas stream or other streams. The disclosure further provides a process for selecting and/or making a regenerable sorbent for CO₂ capture. This solid sorbent can adsorb CO₂. An advantage is that the adsorbent can be rapidly regenerated essentially isothermally with steam and discharge a moist CO₂ stream wherein the CO₂ concentration is higher than that in the original feed gas. Another advantage of the sorbent is that it can be used in an adiabatic reactor design. The sorbent adsorbs water during regeneration with steam and then desorbs water during CO₂ adsorption so that the net reactions are exothermic during steaming and endothermic during adsorption. In this way the system does not require external thermal management on the adsorber and regenerator beds. This modest temperature swing is also important because it thermally assists both adsorption and desorption, again without the addition of external thermal management.

[0066] High process efficiency can be important in order for CO₂ capture to be economical. The regeneration system can be designed to recycle the steam and recover its energy.

[0067] The advantages can include the following: (1) no pressure or temperature swing is required; (2) effective for low CO₂ content gas; (3) achievement of low pressure drop with packed bed can be obtained with reduced footprint stacked fixed beds; (4) optional separation of bed void gases from adsorbed species during regeneration; (5) applicable to a variety of feeds; (6) does not require cooling of sorbent after regeneration prior to adsorption; (7) applicable to feed gas temperatures >100° C.; (8) moist CO₂ discharge from the regeneration cycle can be at concentration greater than the feed CO₂ concentration; (9) option to utilize combustion air before going to combustion device as an additional stripping gas; (10) optional selective purging and recycle to optimize the recovery and purity and energy efficiency.

[0068] The process can be carried out in a cyclic adsorption/regeneration cycle and can include various intermediate purges and stream recycles. Such a process can be performed with co-directional flow of the feed gas and regeneration steam, but can be preferably performed with counter-current feed adsorption/steam regeneration steam flows.

[0069] In an embodiment, the disclosure can include a process for separating CO₂ from a gas stream. In general, the process can include the steps of passing a gas stream comprising CO₂ over a sorbent to adsorb the CO₂ to the

sorbent, and then recovering the CO₂ by desorbing the CO₂ from the sorbent. As noted above, and discussed in more detail below, the adsorption/desorption process can be based on concentration swing and desorptive displacement. Concentration swing adsorption (CSA) processes including the adsorption and desorption steps are governed by change in fugacity of the adsorbate, in this case, CO₂, in the gas stream, in comparison to the adsorbent. The adsorbate, in this case CO₂, is adsorbed when its fugacity is high in the gas stream and low in the adsorbent. Conversely, it is desorbed when its fugacity is reduced in the gas stream relative to the amount in the adsorbent. By way of example, an adsorbent having a high level of CO₂ might still adsorb additional CO₂ when the gas stream has a relatively higher fugacity of CO₂ versus the adsorbent. And an adsorbent having a low level of CO₂ can adsorb CO₂ when the gas stream has a low fugacity of CO₂ so long as the relative fugacity of CO₂ in the sorbent is still lower than the CO₂ in the gas stream. One of ordinary skill in the art would also recognize that “relative fugacity” does not imply relative concentration in the absolute value sense, i.e. does not mean that a 2% adsorbed CO₂ content is necessarily larger than a 1% CO₂ gas level, because the ability of the gas to retain CO₂ versus the ability of adsorbent to adsorb additional CO₂ will be governed by various equilibrium relationships.

[0070] The disclosure includes the process of desorbing the CO₂ from the sorbent. This step might also be referred to as a regeneration step because the sorbent is regenerated for the next passage of a CO₂ gas stream across the sorbent. The desorption of CO₂ from the sorbent comprises treating the sorbent with steam. This desorption step can be driven by a one or more forces. One desorption force is concentration swing, as with the adsorption step above. The partial pressure of CO₂ in the incoming steam is nearly zero, and thus the adsorbed CO₂ can shift to the steam phase. The second desorption force is desorption by displacement. The water molecules in the steam can adsorb onto the sorbent and displace the CO₂ from the sorbent.

[0071] As an optional step, the processes, methods and systems of the disclosure can also include one or more purging step, in which a non-adsorbent gas, i.e. not steam or a CO₂ feed stream, can be passed across the sorbent. The gas can be any gas known to one of ordinary skill in the art, such as for example an inert gas or air. In an embodiment, the purge gas can be a nitrogen stream, an air stream, or a dry air stream. Alternatively the purge gas can be a CO₂ feed gas or steam that is recycled into a process step. The purge step can be conducted at any time. For example, prior to the passing of the CO₂ feed stream across the sorbent, a purge gas can be passed to remove residual and adsorbed water vapor. This purge gas can be run back into the regeneration side in order for the water vapor to be re-adsorbed onto the regeneration side. The purging step can also occur between the adsorption step or steps, and the desorption or regeneration step or steps. The purge gas can be non-reactive, but can still optionally remove adsorbed CO₂ from a sorbent based on concentration swing. Thus, in an embodiment, the purging step can be conducted after adsorption steps, and can be conducted to remove residual gas prior to desorption, which can be optionally recycled into the process. Moreover, the purge step can also be optionally diverted into two streams: 1) an initial purge stream to remove the first gas, and 2) a separate purge stream that can contain the initial purified or desorbed CO₂, which could be optionally cap-

tured as part of the final product stream. Furthermore, in an embodiment, a purging step can be conducted after the desorption or regeneration step(s) is complete, thereby optionally removing residual water and/or steam which can be recycled back into the process. Each purging step can thereby reduce an excess gas stream which can, for example lead to a more efficient process or produce a more CO₂ enriched product stream because a final product stream is not diluted by a preceding gas source. By way of specific example, a purging step conducted after the initial adsorption can remove residual, dilute CO₂ feed stream, leading to a more concentrated CO₂ product stream. The resulting gas stream from the purging step can be recycled into the system, or split into a recycle and a product stream.

[0072] In contrast to numerous processes currently applied to CO₂ processing, the processes, methods and systems of the disclosure do not include either pressure swing adsorption or temperature swing adsorption. The process, method, and systems are nearly isothermal, i.e. there is substantially no temperature change in the overall system. One of ordinary skill would understand that substantially no temperature change, or nearly isothermal, means that the overall temperature of the system does not change by a significant amount. That does not necessarily mean that the temperature is perfectly fixed. Any system can gain or lose heat due to a number of factors, e.g. environmental factors, process fluctuations, etc. However, the disclosed process does not have a temperature change of more than 10° C. in either direction, more than 5° C. in either direction, or more than 3° C., or 2° C., or 1° C. in either direction.

[0073] While the overall process can be nearly isothermal, the individual steps of adsorption and desorption steps can include independent temperature changes. In an embodiment, the adsorption process can result in a temperature decrease in the adsorption step. The adsorption of the CO₂ on a sorbent can be an endothermic process that results in a temperature decrease in the system. Thus, in an embodiment, the temperature of the gas stream during adsorption can decrease by about 30° C. or less, by about 25° C. or less, by about 20° C. or less, about 15° C. or less, about 10° C. or less, or about 5° or less. The temperature of the gas stream during adsorption can decrease by about 1° or more. On the other hand, the desorption process can result in a temperature increase for the desorption step. The desorption can be a net exothermic process that results in a temperature increase. Thus, in an embodiment, the temperature of the gas stream during desorption can increase by about 30° C. or less, by about 25° C. or less, by about 20° C. or less, about 15° C. or less, about 10° C. or less, or about 5° or less. The temperature of the gas stream during desorption can increase by 1° C. or more. However, as discussed, the input and outputs of the overall system result in a process that can be overall nearly isothermal.

[0074] Because the process does not rely on a temperature swing adsorption, the process can be conducted at any temperature in which the gas flows can be maintained across the adsorbent. The process can often include a combustion gas stream and steam as a regeneration stream, so the overall temperature of the process, method, or system can be conducted at greater than about 100° C., greater than about 110° C., greater than about 120° C., greater than about 130° C., greater than about 140° C., greater than about 150° C., or greater than about 160° C. The overall temperature of the process can also be conducted at a temperature as high as the

sorbent can withstand. Thus, the overall temperature of the process can be up to about 300° C., can be up to about 275° C., can be up to about 250° C., can be up to about 240° C., can be up to about 230° C., can be up to about 220° C., can be up to about 210° C., or can be up to about 200° C. However, the process can also be conducted at a temperature below 100° C., at conditions that allow the flow of steam in a gas stream, i.e. according to conditions known to one of ordinary skill as derived from engineering Steam Tables. In an embodiment, the process can be conducted at a temperature between about 120° C. to about 250° C., 120° C. to about 220° C., between about 120° C. to about 200° C., between about 140° C. to about 250° C., between about 140° C. to about 230° C., or between about 140° C. to about 220° C. In an embodiment, the process can be conducted at a temperature between about 120° C. to about 180° C., between about 140° C. to about 160° C., or between about 150° C. to about 165° C.

[0075] The process, method, and systems of the disclosure are also conducted at a nearly constant pressure, or a substantially constant pressure, i.e. there is substantially no pressure change designed as part of the process or system. Again, one of ordinary skill would understand that substantially no pressure change means that the overall pressure of the system does not change by a significant amount. That does not necessarily mean that the pressure is perfectly fixed. Any system can gain or lose pressure due to a number of factors, e.g. environmental factors, process fluctuations, etc. Because the process does not rely on pressure swing adsorption, the process, method, or system can be run at any pressure convenient to one of ordinary skill in the art. In an embodiment, the process, method, or system can be conducted at ambient pressure. However, one of ordinary skill in the art would also recognize that gases in general, and steam in particular, can be modified based on changes in temperature and pressure. For example, the system could be run below 100° C. with steam by running at a slightly reduced pressure. Similarly, higher temperature steam and gas can be used at ambient pressure, but might also be used at higher pressures. However, the pressure of the system overall, whether below, above, or at ambient pressure, does not vary significantly during the process.

[0076] As noted above, a driving force for adsorption and desorption/regeneration of the CO₂ can be a combination of concentration swing and desorptive displacement/adsorption. During adsorption, incoming CO₂ molecules adsorb onto the sorbent and also displace previously adsorbed water (adsorptive displacement or displacement adsorption), during which time the water also desorbs by concentration swing. During desorption/regeneration, the water molecules from the steam adsorb onto the adsorbent and displace the CO₂ (desorptive displacement or displacement desorption). Thus, there are several mechanisms occurring during adsorption and desorption. The CO₂ in the feed stream adsorbs onto the sorbent and also displaces water in the adsorption portion of the cycle, herein defined as the portion of the cycle where CO₂ containing gas is fed to the sorbent, and the sorbent adsorbs CO₂ and desorbs water. The CO₂ then desorbs during steam regeneration portion of the cycle, when the sorbent adsorbs water and displaces CO₂. Further steaming can further remove CO₂ from the sorbent via continued displacement and partial pressure purge desorption. The adsorbed water is then partially or completely

displaced and partial pressure desorbed during the next CO₂ adsorption cycle. Two displacement reactions that are part of the overall adsorption/desorption process can be defined: adsorptive displacement, in which an incoming CO₂ displaces water from the sorbent during an adsorption step; and desorptive displacement, in which an adsorbed CO₂ molecule is displaced from the sorbent by steam during the desorption/regeneration step. These might also be called displacement adsorption and displacement desorption.

[0077] A non-limiting example of the type of reaction involved in adsorption and desorption can be described in the following equations. While the non-limiting example given is specific for a particular potassium carbonate hydrate, many related alkali and alkaline-earth carbonate hydrates may exhibit similar related adsorption and desorption mechanisms. Under low water content conditions in adsorption portion of the cycle:

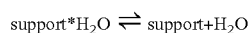

[0078] Under high water content, e.g. steam, conditions in regeneration portion of the cycle:

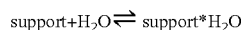
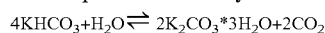

[0079] Alternatively, the adsorption/desorption mechanism can be simply competitive adsorption between CO₂ and H₂O on basic sites wherein under high water vapor conditions the competitive adsorption favors water over CO₂.

[0080] The adsorption and desorption of H₂O on the non-alkali sites is generally not beneficial to the process efficiency. While the adsorption of water on the non-alkali/alkaline sites may serve to help produce a higher concentration moist CO₂ discharge stream, generally it serves to consume steam in a non-productive manner, shifting it to the adsorption effluent. Thus, the preferred sorbent for this disclosure is one which minimizes this part of the adsorption mechanism.

[0081] The disclosure can also include a sorbent based CO₂ adsorption process that includes the steps of passing a gas stream containing CO₂ across the sorbent to adsorb the CO₂ onto the alkalinized substrate, and recovering the CO₂ from the sorbent by passing steam across the CO₂ containing alkalinized substrate to displace the CO₂ with water. The process can include also preparing a sorbent comprising an alkalinized substrate for the sorbent based CO₂ adsorption process. As discussed above, the sorbent based CO₂ adsorption process does not include pressure swing adsorption or temperature swing adsorption. The adsorption of CO₂ includes concentration swing adsorption of the CO₂ onto the sorbent and adsorptive displacement, and the desorption and recovery of the CO₂ can include a combination of concentration swing desorption and desorptive displacement.

[0082] The processes and methods of the disclosure can also include a method for purifying a gas stream that contains CO₂ in order to reduce the CO₂ in the gas stream. The method for removing CO₂ to purify a gas stream can include preparing a sorbent bed having an inlet and an outlet, passing a gas stream containing CO₂ across the sorbent bed from inlet to outlet to adsorb the CO₂ to the sorbent, recovering the purified gas stream depleted of CO₂ at the outlet, and regenerating the sorbent bed by passing steam across the CO₂ containing sorbent. The method does not include a pressure swing adsorption or temperature swing

adsorption process, and uses concentration swing adsorption and adsorptive displacement to remove the CO₂ during adsorption.

[0083] Similarly, the processes and methods of the disclosure can also include a method for purifying a CO₂ gas stream to increase the concentration of the CO₂ in a product stream. The method can include the steps of preparing a sorbent bed having an inlet and an outlet, passing a gas stream containing CO₂ across the sorbent bed to adsorb the CO₂ to the sorbent, and recovering a purified CO₂ stream by passing steam across the CO₂ containing sorbent to generate an enriched CO₂ stream.

[0084] The adsorption and desorption processes, methods and systems of the disclosure can be highly effective at capturing and recovering CO₂ from a stream. In an embodiment of the disclosure, the processes and methods can recover greater than about 60% by volume of the CO₂ from the incoming gas stream, greater than about 65% by volume of the CO₂ from the incoming gas stream, greater than about 70% by volume of the CO₂ from the incoming gas stream, greater than about 75% by volume of the CO₂ from the incoming gas stream, greater than about 80% by volume of the CO₂ from the incoming gas stream, greater than about 85% by volume of the CO₂ from the incoming gas stream, greater than about 90% by volume of the CO₂ from the incoming gas stream, or greater than about 95% by volume of the CO₂ from the incoming gas stream. By analogy then, the initial stream fed across the sorbent during the adsorption phase can be purified of at least about 60% volume of the initial CO₂, at least about 65% volume of the initial CO₂, at least about 70% volume of the initial CO₂, at least about 75% volume of the initial CO₂, at least about 80% volume of the initial CO₂, at least about 85% volume of the initial CO₂, or at least about 90% by volume or greater than about 95% by volume of the CO₂ in the feed stream. In an embodiment, the feed stream can be purified by less than 99.5% by volume.

[0085] As a complement to the reduction of CO₂ in the incoming gas stream, i.e. the CO₂ feed stream, the amount of CO₂ capacity of the sorbent can also be described. The ability of a sorbent to adsorb larger amounts of CO₂ in an individual adsorption step leads to a direct increase in throughput, due to overall capacity. The CO₂ loading of a sorbent can be described by the percent weight increase of the sorbent due to increased amounts of CO₂, based on, for example, the amount of CO₂ extracted from a feed gas versus the total weight of the sorbent. One of ordinary skill would understand that several factors can affect the CO₂ capacity in a given sorbent, including for example the temperature of the system, the relative basicity of the sorbent based on the amount of alkali or alkaline earth component on a given sorbent, and so forth. In an embodiment, a sorbent can have a CO₂ loading of at least about 0.4 wt %, at least about 0.5 wt %, at least about 0.6 wt %, at least about 0.7 wt %, or at least about 0.8 wt %. In an embodiment, the CO₂ loading can be at least about 1.0 wt %, at least about 1.2 wt %, at least about 1.3 wt %, at least about 1.4 wt %, at least about 1.5 wt %, at least about 1.6 wt %, at least about 1.7 wt %, at least about 1.8 wt %, or at least about 1.9 wt %. In an embodiment, the CO₂ loading of a sorbent can be at least about 2 wt %, at least about 2.5 wt %, or at least about 3 wt %. In an embodiment, the sorbent can have a CO₂ loading of less than 20 wt %. The CO₂ loading or capacity of a sorbent can be measured by any technique known to one of

ordinary skill, including for example a TGA analysis, or process evaluation to calculate the amount of CO₂ extracted from a feed gas per amount of sorbent.

[0086] The capacity of a sorbent bed, the concentration of CO₂ in the feed steam, and other process parameters such as bed volume and air velocity can be used to determine the overall cycle time of a given step for an adsorption or desorption bed. In an embodiment, the cycle time an adsorption or desorption bed can be from about 20 seconds to about 30 minutes, including about 20 seconds to about 300 second, about 30 seconds to about 150 seconds, about 1 minute to about 10 minutes, about 1 minute to about 8 minutes, about 1 minute to about 5 minutes, about 1 minute to about 15 minutes, about 1 minute to about 20 minutes, about 1 minute to about 30 minutes, about 3 minute to about 30 minutes, about 5 minute to about 30 minutes, about 5 minute to about 20 minutes, or about 5 minute to about 15 minutes.

[0087] The adsorption step of the disclosure is also relatively insensitive to moisture. The CO₂ feed streams can often contain water. For example combustion gas can contain 8-15 percent water. Other traditional sorbents such as cationic zeolites are almost completely incapable of adsorbing CO₂ in the presence of water. In comparison, the current adsorption process can be conducted in the presence of water without substantial attenuation of the working capacity for CO₂. Thus, in an embodiment of the disclosure, the adsorption step can be conducted at a percent water volume of up to about 35 vol %, up to about 30 vol %, up to about 28 vol %, up to about 25 vol %, up to about 23 vol %, or up to about 20 vol %. In an embodiment, the ratio of water to CO₂ in the feed stream can be greater than 0.5:1, greater than 0.75:1, greater than 1:1, greater than 1.5:1, greater than 2:1, greater than 2.5:1 or greater than 3:1. In an embodiment, the ratio of water to CO₂ in the feed stream can be less than about 4:1, less than about 3.5:1, less than about 3:1, less than about 2.5:1, or less than about 2:1.

[0088] The processes, methods, and systems of the disclosure can be used to adsorb CO₂ from a feed stream having a large range of CO₂ concentrations. In an embodiment, the CO₂ concentration of the feed stream can be at least about 0.5 vol %, at least about 1 vol %, at least about 1.5 vol %, at least about 2 vol %, at least about 2.5 vol %, at least about 3 vol %, at least about 4 vol %, or at least about 5 vol %. The CO₂ concentration can be at least about 6 vol %, at least about 7 vol %, at least about 8 vol %, at least about 9 vol %, or at least about 10 vol %. In an embodiment, the CO₂ concentration in the feed stream can be less than about 50 vol %, less than about 45 vol %, less than about 40 vol %, less than about 35 vol %, or less than about 30 vol %. The processes, methods, and disclosures can be particularly effective at these lower concentrations. However, the system can also be used to extract CO₂ at concentrations above 50 vol % as well, including up to about 100%.

[0089] As discussed above, the process, method, and systems of the disclosure are conducted on a sorbent. The term sorbent can sometimes be applied interchangeably within this disclosure with the term adsorbent, and can be sometimes described as the gas-solids contactor. The sorbent of the disclosure can be an alkaliized substrate or support, sometimes an alkaliized alumina.

[0090] The desirable characteristics of sorbents for use in this process can include adsorption capacity for CO₂ in the presence of water vapor, high selectivity for CO₂ adsorption versus other (non-water) components in the feed gas, low

steam requirement for regeneration, long-term physical stability and adsorption capacity maintenance, low cost per unit weight, and good mass transfer characteristics. The desirable characteristics can be obtained with various supported alkali and or alkaline-earth species.

[0091] Sorbents for this disclosure comprise alkali or alkaline earth metals, oxides, hydroxides, carbonates, bicarbonates or hydrates of any of those species supported on a high surface area substrate. The high surface area substrate can be aluminas, silica-aluminas, carbon, pillared clays, silicas, resins, titanias and other water-stable supports. In an embodiment, the high surface area substrate or support can be alumina. In an embodiment, the sorbents can consist essentially of alkali or alkaline earth metals, oxides, hydroxides, carbonates, bicarbonates or hydrates of any of those species supported on a high surface area substrate; or can consist of alkali or alkaline earth metals, oxides, hydroxides, carbonates, bicarbonates or hydrates of any of those species supported on a high surface area substrate.

[0092] Alkali metals are elements in the left-most column of the periodic table of chemical elements except that hydrogen is not included. Li, Na, K, Rb, Cs, and Fr are generally recognized as alkali-metals. Alkaline-earth metals are in the second column from the left on the periodic table of elements and are Be, Mg, Ca, Sr, Ba, Ra. The basic adsorbent in this process can be an alkalinized alumina. Alkalinized alumina contains at least one alkali or one alkaline component and at least one alumina component. The alkali or alkaline component can be in the pure state or as a compound, e.g. carbonate, hydroxide, oxide, etc. In some cases the alkali or alkaline compound can be in the form of hydrates. The alkali or alkaline surface can attract the acidic CO₂.

[0093] Any support upon which reasonable dispersion of the alkali metal species can be obtained can be useful, including resins, titania, zirconia, aluminas, silicas, clays, mixed inorganics and other inorganic and organic support materials with significant surface areas upon which the alkali metal species can be reasonably dispersed. When the high surface area substrate or support is alumina, the alumina compounds can include sodium aluminate (2NaAlO₂—Na₂O*Al₂O₃), gamma (γ)-Alumina {Al₂O₃(G)}, theta (θ)-alumina, hydrated alumina (Boehmite, Al₂O₃*H₂O), Gibbsite, Bauxite, trine, and bemire. The alumina can have relatively high purity like pseudoboehmite or can be a natural mineral like gibbsite or bauxite. Synthetic aluminas may also be used. Further, gamma alumina, theta alumina, and carbon supports can be effective.

[0094] An embodiment of the disclosure can be the sorbent that includes a support and a metal compound selected from the group consisting of alkali and alkaline earth. In an alternate embodiment, the sorbent can consist essentially of the support and the metal compound, and any associated counterions. The metal compound can contain Li, Na, K, Rb, Cs, Be, Mg, Ca, Sr, or Ba, or a combination thereof; Li, Na, K, Mg, or Ca, or can contain Na or K or a combination thereof. The metal compound can be at least about 5 wt % of the sorbent, at least about 7 wt %, at least about 10 wt %, at least about 12 wt %, at least about 15 wt %, at least about 17 wt %, at least about 20 wt % expressed as the wt % elemental concentration.

[0095] The support in the sorbent, alternatively called a substrate, can be any support one of ordinary skill in the art would select. In an embodiment, the support can be alumina,

titania, zirconia, silica, clay, carbon and mixtures thereof. The support can be alumina. Generally, the support should have a high surface area and pore volume in order optimize the loading levels that the sorbent can demonstrate for CO₂. In an embodiment, the support can have a surface area of at least about 100 m²/g, at least about 150 m²/g, at least about 200 m²/g, at least about 250 m²/g, or at least about 300 m²/g. In an embodiment the support can have a surface area of less than about 1200 m²/g, or less than about 1000 m²/g.

[0096] An embodiment of the disclosure can also be a CO₂ adsorption sorbent, analogous to the disclosure above, wherein the CO₂ adsorption sorbent can adsorb and desorb CO₂ under concentration swing conditions in the presence of water, and without temperature or pressure changes.

[0097] An embodiment of the disclosure can also be a sorbent comprising a metal compound and a support, wherein the sorbent adsorbs carbon dioxide from a wet atmosphere. The sorbent can adsorb the carbon dioxide from the wet atmosphere having up to 35 wt % water, or can adsorb the carbon dioxide and desorb water previously adsorbed from a higher water concentration stream in a wet atmosphere having up to 35% water or less. In an embodiment, the sorbent can adsorb carbon dioxide after the sorbent has been saturated with water at a partial pressure of 1 bar. Furthermore, because the sorbent can operate in a concentration swing system, the sorbent can also desorb carbon dioxide in an atmosphere that is greater than 60% water, or can desorb carbon dioxide from the sorbent previously loaded with carbon dioxide at a partial pressure of 0.02 to 1.0 bar. Thus, the CO₂ concentration in the incoming water stream, e.g. at an inlet to the sorbent in a regeneration/desorption point, can be less than the CO₂ concentration of the outgoing water stream, i.e. at an outlet from the sorbent.

[0098] As discussed above with respect to the non-limiting surface equilibria, the sorbents of this disclosure can also be CO₂/H₂O equilibrium sorbents, where the sorbent will adsorb or desorb carbon dioxide and water, depending on conditions as discussed in this disclosure. Thus, the disclosure also includes a sorbent composed of the metal compound and a support, where the sorbent has a greater capacity for carbon dioxide than the support, the sorbent has a greater capacity for water than the support, and the ratio of carbon dioxide and water on the support varies with the relative concentration of the two sorbates in the environment above the sorbent. The sorbent can adsorb CO₂ in the presence of less than 35% water at a pressure of one bar, and can desorb CO₂ in the presence of greater than 60% water vapor at a pressure of one bar.

[0099] The adsorptive capacity, or loading, of the sorbent has been described with respect to the amount of carbon dioxide that the sorbent can adsorb. Because to the equilibrium conditions the sorbent can operate under during concentration swing adsorption and desorptive and adsorptive displacement, the sorbent can also be described as having a water capacity or loading. In an embodiment, the sorbent can have a water capacity of at least about 1.0 wt %, at least about 1.2 wt %, at least about 1.5 wt %, at least about 1.7 wt %, or at least about 2.0 wt %. In an embodiment, the water capacity can be at least about 2.5 wt %, at least about 2.7 wt %, at least about 3.0 wt %, or at least about 3.5 wt %. Thus, in an embodiment, the sorbent can be described as adsorption-desorption sorbent composed of a metal compound and a support, where the sorbent has a carbon dioxide capacity of at least about 0.5 wt %, a water capacity of at

least about 1 wt %, and a water/carbon dioxide selectivity that varies with the relative concentration of the two sorbates in the environment above the sorbent. The sorbent has a carbon dioxide capacity of at least 0.7 wt %, or at least 1.0 wt %. The sorbent can have a water capacity of at least about 1.5 wt %, or at least about 2 wt %. The sorbent can have a water capacity of less than about 20 wt %.

[0100] An embodiment of the disclosure can also include a carbon dioxide-water equilibrium adsorption surface, comprising a metal compound adhered to the surface of a support. The surface can adsorb carbon dioxide and desorb water in a CO₂-water atmosphere having less than 35 wt % water, and can desorb carbon dioxide and adsorbed water in a CO₂-water atmosphere having greater than 60 wt % water.

[0101] An embodiment of the disclosure can also include a CO₂ adsorption sorbent having CO₂ adsorbed to the surface. The sorbent can include a support, a metal compound comprising Li, Na, K, Rb, Cs, Be, Mg, Ca, Sr, or Ba, or a combination thereof, and adsorbed carbon dioxide. The metal compound can be at least 5 wt % of the sorbent, and the adsorbed carbon dioxide can be at least 0.7 wt %, at least 1.0 wt % wt, or at least 1.5 wt %. The adsorbed carbon dioxide in the sorbent can be any of the weight % loadings listed above. In an embodiment, the wt % carbon dioxide adsorbed to the sorbent can be based on an adsorption step occurring at about standard pressure and at about 140° C.

[0102] An embodiment of the disclosure can include several methods of making the sorbent. The method can include incipient wetness impregnation (or capillary impregnation) of a support, or a slurry/calcinations method where the support is mixed with a solution containing the alkali or alkaline species, dried, and calcined in air to higher temperatures.

[0103] In an embodiment, the method can include treating a support with a solution comprising a metal complex and a solvent, and drying the sorbent. The solution can also consist essentially the metal complex and the solvent. The support can be treated with volume of solution that is approximately equal to the pore volume of the support. Approximately equal can mean an amount of liquid that one of ordinary skill in the art would apply in an incipient wetness technique. For example, the support can have a known pore volume, and the support can be treated with an approximately equal volume of the metal solution. The method can further include the step of calcining the sorbent at a temperature of at least about 350° C., at least about 400° C., at least about 450° C., at least about 500° C., at least about 550° C., or at least about 600° C. The calcining step can be at a temperature of less than about 1200° C., or less than about 1000° C. The calcining step can also include an air flow across the support at a rate of about 3 volume/volume of solid/minute, about 4 volume/volume of solid/minute, or about 5 volume/volume of solid/minute.

[0104] In an embodiment, a method for making the sorbent include preparing pellets of a support by mixing the support in water, drying, and firing at least at about 300° C., mixing the pellets in an aqueous solution comprising water and a metal complex to prepare a pre-sorbent, drying the pre-sorbent, and calcining the pre-sorbent at temperature of at least about 400° C. The pellets may be made by compression pelletizing or extrusion or other techniques known to those skilled in the art.

[0105] In an embodiment, the alkali or alkaline species may be admixed with the support material in a slurry and the slurry prepared into extrudates or pellets, dried, and calcined to a temperature of at least 300° C. An admixed pellet or extrudate formed in this manner may optionally have additional alkali or alkaline species added using the incipient wetness methods described above.

[0106] In an embodiment, the metal complex in the method can be an alkali or alkaline earth metal ion complexed with a counterion. The counterion can be any counterion used by one of ordinary skill in the art, including oxides, hydroxides, carbonates, bicarbonates or hydrates. In an embodiment, the metal complex is an organometallic complex, wherein the counterion is an organic ion. The metal complex can be an acetate or citrate complex with alkali or alkaline metal. The metal complex can be an acetate or citrate complex with Na or K.

[0107] Each of the sorbent compositions noted herein, and sorbents made by the disclosed methods, can be applied to the adsorption/desorption process for CO₂ discussed herein. The compositions can be used in concentration swing processes, and processes using the compositions do not need to rely on either temperature swing or pressure swing adsorption cycles to achieve a CO₂ separation process.

[0108] In an embodiment of the disclosure, the adsorption process can be applied to single stage CO₂ adsorption system. The adsorption system can include a means for contacting the feed gas with the sorbent and means for alternating applying steam to the sorbent. The system can also include any desired purge and recycle streams steps. In addition, the system can include procedures for minimizing the steam requirement and efficient energy management.

[0109] At the start of the adsorption process, a sorbent bed may be highly loaded with adsorbed water. As CO₂ from the feed stream is adsorbed, water is displaced as well as being partial pressure purged from the bed by the non-adsorbed components of the feed gas. Thus, the first effluent during adsorption will be enriched in water vapor. Optionally, this initial portion may be diverted for recycle or other process optimization. As the adsorbed CO₂ front continues moving through the bed, the point will be reached where CO₂ breaks through into the effluent. Thus, a CO₂ lean effluent may be collected. The lean CO₂ effluent can be used to rehydrate the regeneration bed(s) in a recycle or other process optimization design.

[0110] In the initial regeneration of CO₂ loaded bed, the first effluent can be composed of the void gas contained in the bed herein the void gas refers to the non-adsorbed residual gases from the feed. Without limiting this disclosure a particular mechanistic hypothesis this may be understood by considering that water is adsorbed onto the bed in a well defined moving front displacing CO₂ from the adsorbent and pushing the CO₂ ahead of it. The advancing wave of concentrating CO₂ further pushes ahead of it the non-adsorbed void gases, which may also contain a lower concentration of CO₂ and moisture. Thus, as the front advances the first effluent will be void gases and thus they can be diverted separate from the following effluent. The next effluent will be predominantly contain the displaced CO₂ at higher concentration due to the fact that the water is still being adsorbed on the bed and thus the CO₂ while containing some moisture will be at significantly higher concentration than it was in the feed. This feature can distinguish the process from a conventional stripping or partial pressure purge desorption. Following the CO₂ rich effluent, the stream breaks through the bed and further strips the CO₂ off the sorbent.

[0111] A non limiting example of the feed gas composition exiting a bed, collected in a small lab sized cyclic adsorption unit is shown in FIG. 1, where a simulated flue gas composed of 6% CO₂ in N₂ was adsorbed and then steam regenerated. The example was run with the bed held essentially isothermal at -140° C. and at ambient pressure.

[0112] Regeneration or desorption of CO₂ with steam can be single stage or counter-current gas/solid multi-stage. Single stage or counter-current gas/solid multi-stage processes can be carried out in various reactor vessel configura-

rations known to those skilled the art. Such may include moving beds, rotating wheel configurations, simulated moving beds, and such.

[0113] In view of the disclosure of the process and compositions described for CO₂ adsorption and desorption, several process configurations can be constructed that capitalize on several advantages that the process describes.

[0114] A basic CO₂ separation system, **200**, optionally called Capture, Displace, Strip (CDS), is shown schematically in FIG. 2. The CO₂ separation system can include one or more sorbent beds **201**, which is capable of adsorbing and desorbing CO₂. The CO₂ separation system can include an adsorption zone **202**, a CO₂ desorption zone **203**, and optionally a purging stage **204**. In the CO₂ separation system, the sorbent bed or beds **201** can rotate through each of the stages **202**, **203**, and optionally **204**. In the system, CO₂ from a CO₂ feed stream, e.g. a flue gas, is passed across a sorbent bed, in this case two sorbent beds run staggered in time. The use of multiple beds on feed can be done as a way to manage pressure drop, but a single bed per stage is also disclosed. The CO₂ is adsorbed from a CO₂ feed stream. As shown in FIG. 1, the adsorption zone can also include an adsorbent inlet **205** into which the CO₂ feed stream enters, and an adsorbent stage outlet **206**, from which a purified feed stream, which has been depleted or purified of CO₂, exits. A next step in the cycle can be to introduce steam for regeneration in the desorption zone **203** (or alternatively a regeneration zone.) As previously described, the initial effluent upon steam introduction can be primarily comprised of void gases. These gases can be diverted as shown to the atmosphere, or optionally recycled to the feed gas. At a point in the steam regeneration the effluent would be diverted to further CO₂ purification and compression. Thus, steam can enter the desorption zone **203** via desorption inlet **207**, and the effluent gas can exit the desorption zone **203** via desorption outlet **208**. One of ordinary skill would recognize that a valve, not shown, can divert the outlet gas to either route, depending on if it is void gas via the optional discharge or the CO₂ enriched stream. Following the discharge of the high concentration CO₂ effluent portion of the regeneration, rather than the continued use of steam to further partial pressure strip the residual CO₂ from the bed, an optional purging stage **204** can be incorporated to strip the bed with, for example, ambient air. The effluent from this stripping can be advantageously used in a power generation environment to be used as a portion of the combustion air. As would be apparent to those skilled in the art, multiple simultaneous or sequential beds can be used at each step. Indeed, having several beds, staggered in time in the steam regeneration step would have the beneficial effect of smoothing the flow rate to the CO₂ compression step.

[0115] Thus, an embodiment of the disclosure includes a CO₂ separation system that includes a CO₂ adsorption zone, a CO₂ desorption zone, one or more CO₂ sorbent beds, and a CO₂ feed stream. The sorbent bed can alternate between the adsorption zone and the desorption zone, and can adsorb CO₂ from the CO₂ feed stream in the adsorption zone and desorb CO₂ in the desorption zone. The system can include an inlet and an outlet for the adsorption zone where the CO₂ feed stream enters the adsorption zone via the inlet and a purified feed stream exits the adsorption zone via the outlet. The system can also include an inlet and an outlet for the desorption zone, wherein a stream comprising steam enters the desorption zone via the inlet and a CO₂ enriched stream exits via the outlet. As exemplified by FIG. 2, the system can also include a purging stage after the desorption zone, wherein the sorbent bed enters the purge stage and is purged via a stripping gas stream.

[0116] The system can include more than one sorbent bed, including at least two sorbent beds, at least three sorbent

beds, at least four sorbent beds, at least five sorbent beds, at least six or more sorbent beds. The sorbent beds can rotate through each of the adsorption zone, desorption zone, and optionally through a purge stage after the desorption zone. The sorbent beds can include a sorbent, and the sorbent can include a substrate and at least one alkali or alkaline earth component. As noted above, the sorbent can be an alumina component and at least one alkali or alkaline earth component.

[0117] As discussed above, the CO₂ separation system does not rely on a pressure swing or a temperature swing adsorption process, but can be driven by concentration swing adsorption/desorption and adsorptive/desorptive displacement. The adsorption zone operates as a concentration swing process and adsorptive displacement process, and the desorption zone operates as a concentration swing and desorptive displacement process. The entire system can be run isothermally and at a constant pressure.

[0118] As shown in FIG. 2, the adsorption inlet the adsorption inlet and adsorption outlet can be in opposing positions from the desorption inlet and the desorption outlet, relative to the sorbent bed as the bed rotates through the zones.

[0119] In an embodiment of the disclosure, the processes, methods and systems can be developed into a simulated moving bed system, in which sorbent beds are stationary, but the flow of gas into and out of the sorbent beds is scheduled such that a simulated moving bed system is created. By way of example, a five bed simulated moving bed schematic is set forth in FIGS. 3A to 3F. Thus, a countercurrent movement of gas and solids can be simulated using a number of stationary contactors with appropriate arrangement of valves and valve timing.

[0120] A feature of this counter-flow design is that, as the gas travels through the sorbent, it encounters fresher (more recently desorbed) sorbent. At the exit of the reactor the gas stream is in contact with sorbent that has just come from the regeneration mode. This counter current design can provide a driving force to capture a higher percentage of the component gas of interest. This disclosure can then increase the loading with a sorbent whose loading level is controlled by the concentration gradient. For example, sorbents can adsorb more CO₂ at higher concentrations and less at low concentrations. A counter-flow design maximizes the loading by having the sorbent in contact with fresh gas stream (with the highest gas concentration) just prior to going to regeneration mode.

[0121] For this disclosure, a configuration of simulated moving beds can employ a number of stationary contactors. At any one time, some of the contactors can have combustion gas flowing simultaneously in parallel while the other contactors can be exposed to steam flowing in series in the direction opposite to that used for the combustion gas. At intervals, valves are opened and closed to move the relative positions of the contactors one step so that the contactor exposed to combustion gas the longest is now being steamed, and the contactor steamed the longest is now exposed to combustion gas. A series of such steps comprises a complete cycle bringing the contactors back to their starting positions. An example using 8 contactors is shown in FIGS. 4A to 4F. There are 5 different valve positions (shown in Table 1) for a bed, depending on where that bed is in the cycle. The overall cycle comprises 8 steps. The valve pattern for each bed in each step is described in Table 2.

TABLE 3-continued

| | | Valve Opening and Closing Timing for 8-Bed configuration of FIGS. 5A and 5B | | | | | | | |
|-------|-------------------|---|-----------|-----------|-----------|-----------|-----------|-----------|-----------|
| | | Step Number in 8-Step Cycle | | | | | | | |
| | | 1 | 2 | 3 | 4 | 5 | 6 | 7 | 8 |
| Bed C | FG valve C | OPEN | OPEN | OPEN | CLOSED | CLOSED | CLOSED | CLOSED | CLOSED |
| | GFG valve C | C, THEN O | OPEN | OPEN | CLOSED | CLOSED | CLOSED | CLOSED | CLOSED |
| | GFG purge valve C | O, THEN C | CLOSED | CLOSED | CLOSED | CLOSED | CLOSED | CLOSED | CLOSED |
| | Steam valve C | CLOSED | CLOSED | CLOSED | CLOSED | CLOSED | CLOSED | CLOSED | OPEN |
| | CO2 valve C | CLOSED | CLOSED | CLOSED | CLOSED | CLOSED | CLOSED | CLOSED | CLOSED |
| | CO2 purge valve C | CLOSED | CLOSED | CLOSED | CLOSED | CLOSED | CLOSED | CLOSED | CLOSED |
| | Series valve C-D | CLOSED | CLOSED | CLOSED | CLOSED | OPEN | OPEN | OPEN | OPEN |
| Bed D | FG valve D | CLOSED | OPEN | OPEN | OPEN | CLOSED | CLOSED | CLOSED | CLOSED |
| | GFG valve D | CLOSED | C, THEN O | OPEN | OPEN | CLOSED | CLOSED | CLOSED | CLOSED |
| | GFG purge valve D | CLOSED | O, THEN C | CLOSED | CLOSED | CLOSED | CLOSED | CLOSED | CLOSED |
| | Steam valve D | OPEN | CLOSED | CLOSED | CLOSED | CLOSED | CLOSED | CLOSED | CLOSED |
| | CO2 valve D | CLOSED | CLOSED | CLOSED | CLOSED | C, THEN O | CLOSED | CLOSED | CLOSED |
| | CO2 purge valve D | CLOSED | CLOSED | CLOSED | CLOSED | O, THEN C | CLOSED | CLOSED | CLOSED |
| | Series valve D-E | OPEN | CLOSED | CLOSED | CLOSED | CLOSED | OPEN | OPEN | OPEN |
| Bed E | FG valve E | CLOSED | CLOSED | OPEN | OPEN | OPEN | CLOSED | CLOSED | CLOSED |
| | GFG valve E | CLOSED | CLOSED | C, THEN O | OPEN | OPEN | CLOSED | CLOSED | CLOSED |
| | GFG purge valve E | CLOSED | CLOSED | O, THEN C | CLOSED | CLOSED | CLOSED | CLOSED | CLOSED |
| | Steam valve E | CLOSED | OPEN | CLOSED | CLOSED | CLOSED | CLOSED | CLOSED | CLOSED |
| | CO2 valve E | CLOSED | CLOSED | CLOSED | CLOSED | CLOSED | C, THEN O | CLOSED | CLOSED |
| | CO2 purge valve E | CLOSED | CLOSED | CLOSED | CLOSED | CLOSED | O, THEN C | CLOSED | CLOSED |
| | Series valve E-F | OPEN | OPEN | CLOSED | CLOSED | CLOSED | CLOSED | OPEN | OPEN |
| Bed F | FG valve F | CLOSED | CLOSED | CLOSED | OPEN | OPEN | OPEN | CLOSED | CLOSED |
| | GFG valve F | CLOSED | CLOSED | CLOSED | C, THEN O | OPEN | OPEN | CLOSED | CLOSED |
| | GFG purge valve F | CLOSED | CLOSED | CLOSED | O, THEN C | CLOSED | CLOSED | CLOSED | CLOSED |
| | Steam valve F | CLOSED | CLOSED | OPEN | CLOSED | CLOSED | CLOSED | CLOSED | CLOSED |
| | CO2 valve F | CLOSED | CLOSED | CLOSED | CLOSED | CLOSED | CLOSE | C, THEN O | CLOSED |
| | CO2 purge valve F | CLOSED | CLOSED | CLOSED | CLOSED | CLOSED | CLOSED | O, THEN C | CLOSED |
| | Series valve F-G | OPEN | OPEN | OPEN | CLOSED | CLOSED | CLOSED | CLOSED | OPEN |
| Bed G | FG valve G | CLOSED | CLOSED | CLOSED | CLOSED | OPEN | OPEN | OPEN | CLOSED |
| | GFG valve G | CLOSED | CLOSED | CLOSED | CLOSED | C, THEN O | OPEN | OPEN | CLOSED |
| | GFG purge valve G | CLOSED | CLOSED | CLOSED | CLOSED | O, THEN C | CLOSED | CLOSED | CLOSED |
| | Steam valve G | CLOSED | CLOSED | CLOSED | OPEN | CLOSED | CLOSED | CLOSED | CLOSED |
| | CO2 valve G | CLOSED | CLOSED | CLOSED | CLOSED | CLOSED | CLOSED | CLOSED | C, THEN O |
| | CO2 purge valve G | CLOSED | CLOSED | CLOSED | CLOSED | CLOSED | CLOSED | CLOSED | O, THEN C |
| | Series valve G-H | OPEN | OPEN | OPEN | OPEN | CLOSED | CLOSED | CLOSED | CLOSED |

TABLE 3-continued

| | | Valve Opening and Closing Timing for 8-Bed configuration of FIGS. 5A and 5B | | | | | | | |
|-----|----------------------|---|--------|--------|--------|--------|--------------|--------|--------|
| | | Step Number in 8-Step Cycle | | | | | | | |
| | | 1 | 2 | 3 | 4 | 5 | 6 | 7 | 8 |
| Bed | FG valve H | CLOSED | CLOSED | CLOSED | CLOSED | CLOSED | OPEN | OPEN | OPEN |
| H | GFG valve H | CLOSED | CLOSED | CLOSED | CLOSED | CLOSED | C, THEN O | OPEN | OPEN |
| | GFG purge valve H | CLOSED | CLOSED | CLOSED | CLOSED | CLOSED | O, THEN C | CLOSED | CLOSED |
| | Steam valve H | CLOSED | CLOSED | CLOSED | CLOSED | OPEN | CLOSED | CLOSED | CLOSED |
| | CO2 valve H | C, THEN O | CLOSED | CLOSED | CLOSED | CLOSED | CLOSED | CLOSED | CLOSED |
| | CO2 purge valve H | O, THEN C | CLOSED | CLOSED | CLOSED | CLOSED | CLOSED | CLOSED | CLOSED |
| | Series valve H- A | CLOSED | OPEN | OPEN | OPEN | OPEN | CLOSED | CLOSED | CLOSED |

[0123] The simulated moving beds of this disclosure can also be described by the FIG. 6 and the discussion herein. A simulated moving bed system 600 can be a series of fixed sorbent beds (not shown) which “rotate” through several adsorption positions, such as 601, 602, and 611 and several desorption positions, such as 621, 622, and 631. These fixed beds rotate through each of the positions via a series of valves and lines that interconnect each of the beds, and the advancement of the bed through the adsorption and desorption positions and the flow of gases across those beds can be controlled in such a fashion that the fixed beds become part of a simulated moving bed system.

[0124] In the simulated moving bed system 600, a sorbent bed can move through the first adsorption position 601, having a second CO₂ feed stream 604 and a second CO₂-depleted stream 606, to a second adsorption position 602, having a first CO₂ feed stream 603 and a first CO₂-depleted stream 605. The first and second adsorption positions are designated as such because that can typically be the order in which the bed progresses through them. The first adsorption position can have the second CO₂ feed stream and the second CO₂ depleted stream, while the second adsorption position can have the first feed and first depleted streams. The designation of first and second in this instance should not be viewed as a restrictive order for the feeds or streams, but instead as a numerical designation. In some embodiments, the gas streams in the adsorption zone, which would include the first and second adsorption positions, can flow in series such that a first CO₂ feed stream 603 enters the second adsorption position 602, and a first CO₂-depleted stream 605 from the second position could be transferred via lines and valves to become the second CO₂ feed stream 604 that enters the first adsorption position 601 and exits as the second CO₂-depleted stream, 606. Such an order can have a counter-current effect that allows the higher concentration of feed gas to enter the more saturated bed in the second position, and then flow to the less saturated bed in the first position. In this case the bed positions advance in the opposite direction of the gas flow. However, in another embodiment, the two adsorption positions can be run in parallel with the first and second feed streams 603 and 604 coming from a common source, i.e. a flue gas, with each bed receiving the same concentration of CO₂ in the feed gas. The resulting CO₂-depleted streams 605 and 606 can then be combined to form a final depleted gas stream which can be sent to other processes or released via, for example, a flue stack.

[0125] After the second adsorption position 602, the sorbent bed can move into the desorption zone, also called the regeneration zone. The sorbent bed can enter the first desorption position 621, having a second regeneration stream 624 and a second CO₂-enriched stream 626, then move on to the second desorption position 622, having a first regeneration stream 623 and a first CO₂-enriched stream 625. As in the adsorption zone, the designation of first and second desorption position can indicate how the bed progresses through the regeneration system. The first desorption position can have the second regeneration stream and the second CO₂-enriched stream, while the second adsorption position can have the first regeneration feed and first CO₂ enriched streams. The designation of first and second in this instance should not be viewed as a restrictive order for the feeds or streams, but instead as a numerical designation. In some embodiments, the gas streams in the desorption zone, which would include the first and second desorption positions, can flow in series such that the first CO₂-enriched stream 625 exits the second desorption position 622 enters the first desorption 621 as the second regeneration stream 624. Similarly, the regeneration positions could also be operated in parallel.

[0126] While the structures in FIG. 6 show two adsorption positions and two desorption positions, the disclosure herein should not be limited to only a four position system. The simulated moving bed system can also include additional beds, such as the additional earlier bed 611 on the adsorption side, and additional later position 631 on the desorption side. Here, the terms earlier and later are determined based on the timing of the progression of the beds through the system. In a non-limiting example, a sorbent bed could start at adsorption position 611, then proceed to adsorption positions 601 and 602, then onto the desorption positions 621, 622 and 631, before returning to adsorption position 611. Alternatively, bed 611 might instead represent a purge position, such that the bed would start at adsorption position 601, then proceed to adsorption position 602, then onto the desorption positions 621, 622 and 631, move through a purge position 611, and then return to the first adsorption position 601. The simulated moving bed system can include 3 positions, 4 positions, 5 positions, 6 positions, 7, positions, 8 positions, 9 positions, or ten or more positions.

[0127] In view of the discussion of simulated moving beds and systems discussed above, a method for separating and/or purifying a CO₂ gas from a CO₂ feed can be described. In an

embodiment, the method for the separation and/or purification of CO₂ gas from a CO₂ feed stream can include providing at least two adsorption positions and two desorption positions, and at least two fixed sorbent beds that progress through the adsorption and desorption positions. The first adsorption position can have a second CO₂ stream and produce a second CO₂-depleted stream, and the second adsorption position can have a first CO₂ stream and can produce a first CO₂-depleted stream. The first desorption position can have a second regeneration stream and can produce a second CO₂-enriched stream, and the second desorption position can have a first regeneration stream and can produce a first CO₂-enriched stream. Each sorbent bed can have a sorbent, a first port at an end of the bed and a second port at an end of the bed distal to the first port.

[0128] The first step of the method can include exposing the first sorbent bed to a second CO₂ stream at a first adsorption position, and the second sorbent bed to a first CO₂ stream at the second adsorption position. The second step can include exposing the first sorbent bed to the first CO₂ stream at the second sorbent position and the second sorbent bed to the second regeneration stream at a first desorption position. The third step can include exposing the first sorbent bed to the second regeneration stream at the first desorption position and the second sorbent bed to a first regeneration stream at a second regeneration position. And, an optional fourth step can include exposing the second sorbent bed to the second CO₂ stream at the first adsorption position and the first sorbent bed to the first regeneration stream at the second desorption. The fourth step can instead include advancing the beds through downstream desorption positions until each sorbent bed returns to the beginning of the adsorption zone.

[0129] As discussed previously, the method can be conducted at substantially constant temperature and substantially constant pressure with neither a temperature swing nor pressure swing. In an embodiment, the regeneration streams comprise steam, or can be a steam stream.

[0130] In a further embodiment, the method can include providing a system of valves and lines connecting at least two fixed sorbent beds such that a bed advances from a first adsorption position to a second adsorption position to a first desorption position to the second desorption position, and optionally back to the first adsorption position.

[0131] As noted previously, and as shown in some of the nonlimiting valve schedules shown above, the two or more adsorption positions can be run in parallel. In an embodiment, the CO₂-feed stream can be directed into both the first CO₂ stream of the second adsorption position and the second CO₂ stream of the first adsorption position such that the two adsorption positions operate in parallel. The first and the second CO₂ depleted streams from the second and first adsorption positions can also be combined together for collection or additional processing. In an alternate embodiment, the two or more adsorption positions can be run in series. Thus the first CO₂-depleted stream from the second adsorption bed can be used as the second CO₂ stream in the first adsorption position such that the two adsorption positions operate in series, and the second CO₂-depleted stream is collected.

[0132] When a new sorbent bed assumes a first adsorption position, it can have an initial void gas, such as a residual steam stream after exiting the desorption/regeneration stage. In one embodiment, the effluent from the sorbent bed can be

diverted to a purging stage. In an alternative, the first adsorption position can include an optional purge. Thus, a first portion of the second CO₂ depleted stream from the first adsorption position can be diverted as a purge stream before switching to collection of the CO₂-depleted stream.

[0133] The purge stream can also be utilized as a part of the overall scheme as a recycled gas flow or alternate flow. In an embodiment, the stream, optionally a portion of the feed stream, can be introduced into a bed which just advanced out of the desorption zone, and the effluent from that bed can be directed to a bed which has just advanced out of the adsorption stage. A second effluent resulting from the bed which has just advanced out of the adsorption can be directed either to a stack or to be recycled within the system. A non-limiting example of this can be demonstrated in FIG. 35. In an embodiment, the purge steps can include introducing a separate stream, optionally a portion of the feed stream or a non-adsorbing gas, into a bed which just advanced out of the desorption zone, in order to push out the dead volume gas and adsorbed steam of this bed back into a desorption zone bed. A non-limiting example can be demonstrated in FIGS. 22 and 34.

[0134] In an embodiment of the disclosure, the desorption positions can be run in series. The first CO₂-enriched stream from the second desorption position can be used as the second regeneration stream in the first desorption position. In another embodiment, one or more desorption positions could be run outside of the series, such as one or more beds being run in parallel, such as to remove residual CO₂ feed gas for a recycle stream. In an embodiment, the beds can be desorbed in parallel, and the resulting streams combined or selectively diverted, depending on gas content of the parallel streams.

[0135] Another aspect of the disclosure can be that the gas flows in adsorption are conducted in one direction across the sorbent bed, but the regeneration can be advantageously conducted with flows in the opposite direction. In an embodiment the CO₂ streams enter each sorbent bed in the adsorption positions via the first port, and the CO₂-depleted stream exits via the second port. The regeneration streams enter each of the sorbent beds in the desorption positions via the second port, and the CO₂-enriched stream exits via the first port.

[0136] In view of the disclosure, a simulated moving bed system can be described. In an embodiment, the simulated moving bed system for CO₂ purification/separation can include a plurality of fixed sorbent beds, each sorbent bed comprising a sorbent, a first port at an end of the bed and a second port at an end of the bed distal to the first port; an adsorption zone and a desorption zone; and a series of valves and lines interconnecting each of the beds via the first and second ports; a CO₂ feed stream, a steam stream, a CO₂-depleted stream, and a CO₂-enriched stream, and one or more purge streams. The system operates under substantially constant pressure and constant temperature with neither temperature swing nor pressure swing

[0137] When a bed is in an adsorption position, the first port of the bed can be connected to either the CO₂ feed stream or the second port of another sorbent bed in the adsorption zone which is generating a CO₂ depleted stream. The second port of the bed can be either connected to a first port of another bed, to a purge line, or to a unit collecting the

CO₂-depleted stream or optionally diverted to purge for a portion of time. Thus, the beds operating in an adsorption zone can operate in series.

[0138] In an alternate embodiment, when any bed is in an adsorption position, the first port is connected to the CO₂ feed stream and the second port is connected to a unit collecting the CO₂-depleted stream, and bed earliest in the adsorption zone optionally connected to a purge line. Thus, all the beds operating in an adsorption zone can operate in parallel.

[0139] In the desorption, the beds operating in the desorption zone can operate in series. The bed in the desorption zone longest receives an initial regeneration stream, typically a steam stream, and each bed can be connected via a port to the bed next longest in the desorption zone. The bed earliest in the desorption zone can emit via a port the CO₂-enriched stream for collection or additional processing. When a bed is in a desorption position, the first port can be connected to the second port of another bed, and the second port can be connected to the first port of another bed, with the exceptions that the second port of the bed longest in the desorption zone is connected to the steam stream, and the first port of the bed earliest in the desorption zone is connected to a unit for collecting the CO₂-enriched stream or optionally diverted to purge for a portion of time. In a specific embodiment, the purge steps can consist of introducing a separate stream, optionally a portion of the feed stream, into a bed which just advanced out of the desorption zone, and directing the effluent to a bed which has just advanced out of the adsorption zone; directing the ultimate effluent either to a stack or to be recycled within the system. In another specific embodiment, the purge steps can consist of introducing a separate stream, optionally a portion of the feed stream or a non-adsorbing gas, into a bed which just advanced out of the desorption zone, in order to push out the dead volume gas and adsorbed steam of this bed back into a desorption zone bed.

[0140] The fixed adsorbent beds in the simulated moving bed system can have any aspect ratio one of ordinary skill would include, where the aspect ratio is a measure of the length of the sorbent bed versus its width. In an embodiment, the aspect ratio should provide a superficial gas residence time (flow in volume per unit of time divided by bed cross-sectional area) of at least 5 seconds.

[0141] In a simulated moving bed system, the system can have several beds that alternate between an adsorption zone, a desorption zone, and optionally one or more purge zones. The ratio of beds operating in an adsorption zone can generally be equal to or less than the number of beds operating in a desorption or regeneration zone. In an embodiment, the ratio of beds in adsorption to desorption is between about 1:1 and 1:5, between about 1:1 and 1:4, between about 1:1 and 1:3, and between about 1:1 and 1:2.

[0142] An embodiment of the disclosure can also include a counter-flow moving adsorber in a reactor, where the sorbent moves vertically down with the gas flow vertical up. (FIG. 7). The gas stream flows up through the adsorber bed (Reactor #1) counter current to the sorbent pellets which fall vertically down through the bed. The sorbent pellets are circulated through to the regeneration bed and back to the adsorber bed. The sorbent can be transported by many mechanisms including pneumatic transport, screw conveyor and bucket elevator. Reactor #2, the regenerator, can be any moving bed design where the flow contact between the

sorbents and gases is counter current. It can be a reactor where the sorbent is transported up as the gas flows down. In another embodiment, the regenerator can also be another vertical falling moving bed.

[0143] An embodiment of the disclosure can also include a vertical flowing moving bed, as illustrated in FIG. 8. The absorber bed design can be a vertical falling moving bed with an insulated screw conveyor belt to convey the solids through the steam stripper (regenerator). Flue gas can flow up through the adsorber bed counter current to the sorbent pellets which flows down. The solids can move up through the screw conveyor with the steam flowing down in counter flow to remove the absorbed CO₂. The screw conveyor could comprise of vertical, inclined, or horizontal conveyors and/or combinations thereof.

[0144] An embodiment of the disclosure can also include a moving bed where the solids are moved with a bucket elevator, as shown in FIG. 9. In this embodiment, the adsorber bed and regenerator beds are both vertical falling moving beds and a bucket elevator circulates the sorbent up to the upper bed. In both beds the gas stream can move up while the sorbent can fall down. The upper reactor is shown as the regenerator, however, the bed's location could also be reversed with the regeneration bed in the upper position. The bucket elevator may comprise a centrifugal discharge, or continuous discharge or a drag conveyor.

[0145] An embodiment of the disclosure can then be a circulating moving bed system having a sorbent, a CO₂ feed stream, a regeneration stream, an adsorption reactor and a desorption reactor. As shown in several of the previous non-limiting examples, the system can include an adsorption reactor and regeneration reactor. The adsorption reactor can have a first entry point for the sorbent at an end of the adsorption reactor, a second entry point for the CO₂ feed stream distal to the first entry point, a sorbent exit point for the sorbent proximal to the second entry point, and a feed stream exit point proximal to the first entry point. The regeneration reactor can have a first entry point for the sorbent at an end of the regeneration reactor, a second entry point for the regeneration stream distal to the first entry point, a sorbent exit point for the sorbent proximal to the second entry point, and a regeneration stream exit point proximal to the first entry point.

[0146] The moving bed systems can incorporate each of the discussions set forth throughout the application, including the lack of a temperature swing or pressure swing process, and the use of sorbents disclosed herein.

[0147] The moving bed systems of this disclosure can also include a sorbent transport system to move sorbent between each reactor. As shown in some non-limiting examples, the sorbent transport system can be included in either the adsorption or regeneration reactor, or both, and can move sorbent in a direction opposite to the direction of either the CO₂ feed stream or the regeneration stream, respectively.

[0148] The moving bed systems of this disclosure can also be described as part of a process. In an embodiment of the disclosure, a process for the separation and/or purification of CO₂ from a CO₂ feed stream can include adsorbing the CO₂ on a sorbent by passing the CO₂ feed stream through the adsorption reactor, the adsorption reactor comprising a first entry point for the sorbent at an end of the adsorption reactor, a second entry point for the CO₂ feed stream distal to the first entry point, a sorbent exit point for the sorbent proximal to the second entry point, and a feed stream exit

point proximal to the first entry point; and desorbing the CO₂ from the sorbent in the regeneration reactor, the regeneration reactor comprising a first entry point for the sorbent at an end of the regeneration reactor, a second entry point for the regeneration stream distal to the first entry point, a sorbent exit point for the sorbent proximal to the second entry point, and a regeneration stream exit point proximal to the first entry point.

[0149] In an embodiment of the disclosure, the counter flow moving bed can also be a rotating moving bed where the sorbent is stationary inside a vessel which itself rotates such that the gas flows across it in a counter-flow manner. The schematic diagram of such a counterflow moving bed is shown in FIG. 10. This bed rotates in a circle like a carousel. In contrast, other rotating wheel applications have gas flow that comes in from the top (roof) or bottom (floor) planes of the carousel. (U.S. Pat. Nos. 6,447,583, 5,503,222, 6,527, 836). These rotating beds are essentially multiple fixed beds with a sliding seal instead of valves. In some other rotating wheel applications pressure swing is used as the regeneration mechanism. This type of rotating bed is essentially a set of fixed bed reactors. A fixed bed reactor must provide for both the mass transfer zones and extra capacity to store sorbent. Since there is always some residual gas in the reactor, very frequent cycling must be avoided to prevent contamination of one stream by the other. Consequently the fixed beds are about 3 to 5 times larger than the counter-current rotating bed.

[0150] In an embodiment of this disclosure, the gas flows in the rotating moving bed from the sides of the rotating wheel as shown in an embodiment in FIG. 10. This flow path design enables counter current contact between the gas and the sorbent. The stream containing the gas to be removed runs across one section the wheel. On the other side the regeneration gas stream flows across. In this disclosure the regeneration is also by contact with another gas rather than pressure swing or temperature swing. There is a transition region between the adsorption and regeneration sections where the sorbent is sealed off to keep the adsorption and regeneration spaces separate. The section of the sorbent that is in this transition region changes as the wheel rotates. A feature of the rotating wheel design is that the energy requirement to circulate the sorbent is lower than for other sorbent circulation methods such as pneumatic transport, screw conveyor, and bucket elevators. In contrast to the pneumatic transport, screw conveyor and bucket elevator, which move sorbent vertically, the rolling bed on railroad wheels and tracks and the rolling bed on truck tires and concrete needs to only move the material horizontally. There is a substantial cost benefit to just overcoming the rolling friction rather than have to move solids up a vertical lift.

[0151] The efficiency benefits of counterflow contact are well established in the design of regenerative heat exchangers which also use a counter-current flow design. Regenerative heat exchangers can have two fluids (generally the same fluid) following on each side in opposite flow directions. The fluid flows to one side of the heat exchanger where it can be heated (or cooled). After exiting the heat exchanger, it may go through an external processing step, and then be flowed back through the heat exchanger in the opposite direction. In generally, the fluid will cycle through one side of the heat exchanger, go through a process and then go back through the heat exchanger on the other side in the other direction. This is useful because with the counter current flow, the fluid

incoming to a process is heated using the energy contained in the fluid exiting this process. Thus, the regenerative heat exchanger can give a considerable net savings in energy, since most of the heat energy is reclaimed nearly in a thermodynamically reversible way. This type of heat exchanger can have a thermal efficiency of over 90%, transferring almost all the relative heat energy from one flow direction to the other. Only a small amount of extra heat energy needs to be added at the hot end, and dissipated at the cold end, even to maintain very high or very low temperatures. The counter-current approach of the regenerative heat exchanger can be used in ad/absorbents process design to achieve a high efficiency. In this case, the gases flows are in a countercurrent manner and there is a concentration gradient rather than a temperature gradient driving the process.

[0152] An embodiment of the disclosure can also be a counter-flow rotating wheel bed design with concentration swing. A schematic of the embodiment of this design for CO₂ capture from flue gas with steam stripping regeneration is shown in FIG. 12 along with a view of the exterior of the design, in FIG. 11. The combustion flue gas stream flows in from the sides of the rotating wheel as shown. The wheel rotates in the opposite direction as the gas flow path. This provides counter current contact between the flue gas and the adsorbent. Flue gas flows horizontally across a section of the wheel and adsorbs CO₂. With the counter-flow design the flue gas with the lowest concentration for CO₂ near the gas flow exit is in contact with the most recently regenerated sorbent. This feature enables the lowest concentration of CO₂ leaving the reactor. On the other section of the rotating wheel the regeneration steam flows across, also in a counter current path to the sorbent rotation direction and desorbs the CO₂ from the sorbent. With the counter current flow path the most highly loaded adsorbent is in contact with the steam leaving the reactor. This feature yields the highest possible CO₂ concentration in the regeneration gas outlet.

[0153] There is a transition region between the adsorption and regeneration sections where the sorbent is sealed off to keep the adsorption and regeneration spaces separate, as shown in FIG. 13. The section of sorbent that is in this transition region changes as the wheel rotates. In a non-limiting example, the rotating wheel can be made of 24 sorbent cells, and each cell could about 40 ft tall by 39 ft wide by 4 ft. Doors on each cell can allow gas to flow through or can close to seal off sections in the transition region. A schematic of the transition region is show in above. Each transition zone isolates up to two sorbent cells. As the set of doors one cell opens up, the other sets of doors on the adjacent cell is still in place to block reverse flow. In this embodiment, the opening and closing of these doors is activated by the flow of gas through the sorbent. Doors close in the transition region because the pressure gradient is in the reverse direction. The doors are designed to not allow reverse flow. The doors are hinged and do not open more than 85° by the hinge design. The sealing does not have to be perfect. With a 1/32 inch gap, the doors will stop >99.5% of the total flow. The doors when closed are not perfectly sealed but are shimmed after the sorbent is loaded to minimize the gap between the door and its frame when closed. The interior vertical cross section showing these doors is shown above. There is also a set of doors on the side of the rotating bed which are opened by mechanical means to allow flow into or out of the side of the rotating bed.

[0154] The rotating bed can be inside a non-moving exterior structure to protect the internal reactor from weather, as shown in FIG. 14. The exterior wall can be insulated on the outside to maintain the temperature of the system. The non-moving screen at the top of the structure allows air to move by natural convection and to keep the bottom part of the rotating moving bed near ambient temperature. The concrete roadway or floor provides the support for the rotating moving bed.

[0155] An embodiment of the current disclosure can then be a rotary moving bed assembly such as described above. The rotary moving bed can include a rotational assembly having a vertical axis of rotation and a plurality of fixed sorbent cells positioned horizontally relative to the axis of rotation and each cell or a combination of cells filling the vertical space within the rotational assembly such that air substantially cannot bypass the sorbent cells, a non-moving exterior structure; a regeneration stream inlet and outlet; and a CO₂ feed stream inlet and outlet. One of ordinary skill would understand that substantially cannot bypass does not mean that no gas bypasses the sorbent cell, but that the rotary bed is designed such that no bypass is intentionally designed into the assembly. Some level of leakage and a lack of airtight fit might be expected in constructing a rotary bed assembly of the disclosure. The fixed sorbent cell rotates through the assembly in one direction while the two gas flows travel in the opposite direction. Thus, a countercurrent flow for both adsorption and desorption can be established. Thus, in an embodiment, a regeneration stream can flow from the regeneration inlet to the regeneration outlet in the opposite direction of rotation for the rotational assembly, and a CO₂ feed stream flows from the CO₂ feed stream inlet to the CO₂ feed stream outlet in the opposite direction of rotation for the rotational assembly.

[0156] As demonstrated by the previous figures, an embodiment of the disclosure can also include the CO₂ feed stream and the regeneration feed stream which flow in a horizontal direction relative to the vertical axis of rotation. Note that this flow differs from the rotary bed processes discussed earlier in which the air flow was across the cells in a vertical direction, leading to an overall ineffective use of space and size of the beds. With the gas flow from inlet to outlet across the fixed beds, a region between the regeneration inlet and outlets can form a desorption zone and a region between the CO₂ feed stream inlet and outlet form an adsorption zone. The adsorption zone can contain a plurality of sorbent cells in contact with CO₂ feed stream, and the sorbent cells in the desorption zone are moving in the opposite direction from the feed stream. Similarly, the desorption zone can contain a plurality of sorbent cells in contact with regeneration stream, and the sorbent cells in the desorption zone are moving in the opposite direction from the regeneration stream. As discussed, the gas flow across the multiple beds can occur in a countercurrent fashion, such that the beds with highest concentrations of adsorbed CO₂ are exposed to the feed gas with the highest CO₂ concentration, and lower concentration beds are exposed to feed gases with low amounts of CO₂ but can still adsorb the CO₂ due to the large amount of capacity those beds have.

[0157] The rotary moving bed also contains transition zones in the region between the CO₂ feed stream outlet and the regeneration feed stream inlet and the region between the regeneration stream outlet and CO₂ feed stream inlet. Sor-

bent cells passing through these zones are not in contact with either the regeneration stream or the CO₂ feed stream.

[0158] Another embodiment of the disclosure can be length of time a sorbent cell spends in each zone, or a residence time. A sorbent cell can have a residence time, measured as a percentage of time required to make one cycle around the rotating bed, in either the adsorption or desorption zone of at least about 30% of one cycle, at least about 35% of one cycle, or at least about 40% of one cycle. Similarly, the residence time of a sorbent cell in a transition zone is less than 20% of one cycle, less than 15% of one cycle, or less than 10% of one cycle. Alternatively, the length of time a sorbent cell spends in a zone can be described with respect to the number of total sorbent cells in a given zone at a specific point in time. In an embodiment, the adsorption zone can have at least about 30% of the total sorbent cells in the zone, at least 35% of the total sorbent cells, or at least 40% of the total sorbent cells. Similarly, the desorption zone can have at least about 30% of the total sorbent cells in the zone, at least 35% of the total sorbent cells, or at least 40% of the total sorbent cells.

[0159] The sorbent cells of the rotary moving bed can contain the sorbent as described and disclosed herein.

[0160] In an embodiment, the disclosure can also include a process for the separation and/or purification of CO₂ gas from a CO₂ feed stream, which includes feeding a CO₂ containing feed stream into a CO₂ feed stream inlet of a rotary moving bed and collecting a CO₂-depleted feed stream at a CO₂ feed stream outlet of the rotary moving bed and feeding a regeneration stream into a regeneration stream inlet of the rotary moving bed and collecting a CO₂-enriched stream at the regeneration stream outlet of the rotary moving bed, wherein the regeneration stream flows from the regeneration inlet to the regeneration outlet in the opposite direction of rotation for the rotational assembly, and the CO₂ feed stream flows from the CO₂ feed stream inlet to the CO₂ feed stream outlet in the opposite direction of rotation for the rotational assembly. The rotary moving bed can be as described and disclosed.

[0161] In an alternate embodiment, the sorbent technology can alternatively be applied to a rotary moving bed as shown in FIG. 15. The CO₂ feed stream and the regeneration stream each flow in a direction parallel to the axis of rotation, e.g. a rotary moving bed rotating on a vertical axis would have each stream flowing across the sorbent beds in a vertical direction. Adsorption can be conducted on one portion of the rotary wheel, with the CO₂ feed stream flowing up through the sorbent beds, and desorption/regeneration can be conducted on another portion of the rotary wheel, with the regeneration stream flowing down through the sorbent beds. In an embodiment, the gas stream and the regeneration stream can flow in opposite directions, as shown in FIG. 15, or the two streams can flow in the same direction. The portions of the wheel in regeneration or adsorption need not be equal.

[0162] In another embodiment, the rotary wheel can be arranged such that counter-current staging of gas flows and solids movement can be achieved, as shown in FIG. 16. The wheel is a fixed bed of sorbent which rotates in the direction shown. The segments represent individual stationary ducts which lead gas flows into and out of the wheel. As the wheel rotates, the gas flows are led in directions counter to the direction of rotation, thereby exposing the sorbent to con-

centrations of the carbon dioxide that improve utilization of the sorbent and minimize the amount of displacing steam required.

[0163] In another embodiment, the simulated moving bed strategy discussed above can be applied to a rotary wheel by creating different flows of gas into and out of different zones of the rotary wheel. As illustrated in FIG. 17, the segments identified by different patterns represent divisions of the ducting leading into and out of the wheel, which is a fixed bed that rotates in the direction shown by the arrow in the center. In the legend, FG represents the flue gas being treated, and GFG the “green” low Carbon dioxide product. The lines connecting the segments represent ducts that recirculate the streams shown to other ducts.

[0164] In constructing the sorbent beds used within the methods, processes, and systems of the disclosure, the sorbent can be placed in the beds using any method known to one of ordinary skill in the art. In an embodiment, the sorbent can be contained as free particles that move through a system in a countercurrent fashion, such as in the vertical moving beds in FIG. 7 or 8. Alternatively, the sorbent can also be contained with individual modules, such as the module of FIG. 18A. The sorbent can be contained in an individual module which is open at the top and having a perforated bottom to allow gas flow with retaining the sorbent. The sorbent particles can then be contained as packed beds in the modules, and layered beds of modules can then be assembled using sorbent modules and inter-bed spacers or flow channels as shown in FIG. 18B to produce the layered beds shown in FIG. 19A, viewed from the inlet and outlet ends, and FIG. 19B, viewed from the side. The layered beds can provide for high volume gas flow with low pressure drop. Gases introduce from the right flow down through the beds and out the left side; gases introduced from the left flow up and out the right side.

[0165] As an alternative to individual sorbent containing modules, it is envisioned that a stacked bed configuration could also be achieved with support grids in each layer and loose adsorbent particles as extrudates or other low pressure drop forms without the use of individual sorbent modules.

[0166] Another configuration that provides the benefits of segmentation involves arranging the segments as vertical paced beds with flow channels that provide for parallel horizontal flow of gases, as illustrated in FIG. 20. The beds are contained within screens mounted vertically. Adsorbent is filled from the top and dumped from the bottom. Process gas flow is in the top and out the bottom, or in the bottom and out the top. The flow divides into the channels between beds, goes through the beds and then out the channels to the other side and collects to flow out.

EXAMPLES

Example 1—Sorbent Preparation and Characterization

[0167] An alkalized alumina adsorbent was prepared from alumina powder (boehmite) and sodium carbonate. The boehmite and sodium carbonate were mixed in distilled water. The resulting solution was filtered and sediment dried. This sediment mixed with a nitric acid solution was extruded into pellets and fired.

[0168] As an example of a sample preparation, 210 g Boehmite V-700 (UOP), 132 g Na_2CO_3 and 900 ml H_2O were mixed at 90° C. for 2 hours. The resulting solution was

filtered, and the sediment was left to dry over night at room temperature. First, 380 g of the sediment material were put in the drying oven for 3.5 hours. Next, 309.4 g of the dried material were mixed with 163 ml of the HNO_3 solution (0.75 ml HNO_3 /20 ml H_2O). Pellets were extruded to 1/8" diameter pellets, dried at room temperature and then calcined with heating from room temperature up to 100° C. at 0.2° C./min. for 2 hours and then heating 100° C. up to 650° C. at 0.5° C./min. for 4 hours.

[0169] This sorbent was characterized in a fixed bed where it was cycled under simulated coal flue gas (13.7% CO_2 , 9.0% H_2O with the balance N_2) and regenerated with 1 atm of steam. The fixed bed was operated in a counter flow mode with the simulated flue run down and the steam flow up through the reactor. The GHSV of the simulated flue gas was 2500 hr^{-1} during the 2 minute adsorption step and the GHSV of the steam was 2500 hr^{-1} during the 4 minute regeneration step. The adsorbent had a dynamic CO_2 loading capacity 0.8 wt %.

Example 2—Sorbent Preparation and Characterization

[0170] An alkalized alumina adsorbent was prepared from alumina powder (boehmite) and sodium bicarbonate. The boehmite and sodium bicarbonate were mixed in distilled water. The resulting solution was allowed to settle, the solution decanted off and the precipitate dried. The precipitate was extruded into pellets with a sodium nitrate solution and fired. As an example of a sample preparation, 8903 g Boehmite Versal-700 (UOP), 5594 g NaHCO_3 , and 38.1 L H_2O were mixed at room temperature for 18 hours. The solution was then allowed to settle and the excess solution was decanted off. The precipitate was dried at 150° F. Dried powder (8700 g) were mixed with 2% Methocel F4M (Dow) (174 g) and then combined with 8265 g of 3.75% NaNO_3 solution. This material was extruded to 1/8" pellets and air dried overnight and then fired at 400° C. for 4 hours.

[0171] This sorbent was characterized in a fixed bed where it was cycled under simulated natural gas flue gas (4.1% CO_2 , 8.3% H_2O with the balance N_2) and regenerated with 100% steam at ambient pressure, as shown in FIG. 21 (CO_2 feed and effluent flow rates under cycling with 4.1% CO_2 , 8.3% H_2O simulated flue gas (GHSV 2080 hr^{-1}) and steam regeneration (GHSV 1280 hr^{-1}). Temperature decreases during adsorption of CO_2 from flue gas and temperature increased with CO_2 desorption during steam regeneration. Dynamic CO_2 loading capacity is 0.7 wt %. Adsorbent prepared according to adsorbent preparation Example 2.) The fixed bed was operated in a counter flow mode with the simulated flue run down and the steam flow up through the reactor. The GHSV of the simulated flue gas was 2080 hr^{-1} during the 11 minute adsorption step and the GHSV of the steam was 1280 hr^{-1} during the 13 minute regeneration step. The adsorbent had a dynamic CO_2 loading capacity of 0.7 wt %. As is characteristic of this process without the removal of heat from the bed, the temperature during adsorption of CO_2 from the flue gas was lower at 140° C. and during regeneration it rose to 160° C. It steadily oscillated between these temperatures.

Example 3—Sorbent Preparation and Characterization

[0172] An alkalized alumina adsorbent was prepared from alumina powder (gibbsite) and sodium bicarbonate. The

boehmite and sodium bicarbonate were mixed in distilled water. The resulting solution was filtered and precipitate dried. This precipitate was mixed with a methocel FM and Volclay and was extruded with Boehmite solution (6.7% conc) into pellets and fired.

[0173] As an example of a sample preparation, 153.5 g Alcan WH31 (Alcan) which had been fired at 275° C. for 8 hr, 96.5 g NaHCO₃ and 657.5 ml H₂O were mixed at 90° C. for 1 hours. The resulting solution was filtered, and the filtrate was left to dry over night at room temperature and then dried at 100° C. for 1 hours. 150 g of the dried material were dry mixed with Volclay 353 CER (American Colloid Company) (16.7 g) and Methocel F4M (Dow) (3.34 g) and then mixed with 93.52 g of the Boehmite solution (6.7% conc). Pellets were extruded to 1/16" diameter pellets, dried at room temperature and then calcined at 550° C. for 4 hours.

[0174] This adsorbent was characterized in a fixed bed where it was cycled under simulated coal gas flue gas (12.3% CO₂, 13.8% H₂O with the balance N₂) and regenerated with 1 atm steam. The fixed bed was operated in a counter flow mode with the simulated flue run down and the steam flow up through the reactor. The GHSV of the simulated flue gas was 1900 hr⁻¹ during the 5 minute adsorption step and the GHSV of the steam was 900 hr⁻¹ during the 10 minute regeneration step. The adsorbent had a dynamic CO₂ loading capacity 0.57 wt %. As is characteristic of the process without the removal of heat the temperature during adsorption of CO₂ from the flue gas was lower at 191° C. and during regeneration it increased to 198° C. It steadily oscillated between these temperatures.

Example 4—Sorbent Preparation

[0175] The methods of/composition of the adsorbent in examples 1 and 2 can be extended to other alkalinized alumina adsorbent compositions.

[0176] The methods of/of the adsorbent examples 1 and 2 where the first component is any alkali or alkaline earth metal. A further example is where the adsorbent is comprised of sodium carbonate or soda ash (Na₂CO₃), potassium carbonate, trona (trisodium hydrogencarbonate alcinati Na₃H(CO₃)₂·2H₂O), baking soda (NaHCO₃). Sodium aluminate (2NaAlO₂—Na₂O*Al₂O₃), gamma (γ)-Alumina {Al₂O₃(G)}, hydrated alumina (Boehmite, Al₂O₃*H₂O), Gibbsite, Bauxite, sodium aluminate, calcium silicate (e.g. portland cement). Some low Gibbsites that can be used are Alcan H10 (\$84/ton), Alcan WH31 (\$133/ton), and Alcan OP-25 (\$135/ton).

Example 5—Sorbent Preparation

[0177] γ-Al₂O₃ extrudates were used as support to deposit Na₂CO₃. It has surface area of 306 m²/g, 0.85 cm³/g pore volume and pore size centered on 73 Å. The aqueous solution containing sodium carbonate was prepared by dissolving sodium carbonate in distilled H₂O. The sorbent of Na₂O/γ-Al₂O₃ was prepared by an incipient wetness technique. As an example of sample preparation, 42.401 g of sodium carbonate was dissolved in 100 g of distilled water. The total solution volume of Na₂CO₃/H₂O adjusted with distilled water was 133 ml. 200 g of γ-Al₂O₃ extrudates were impregnated with the solution by incipient wetness. The sample was dried in air at 250° F. for 16 hours and calcined in air at 1000° F. for 6 hours. The furnace was ramped at rate of 5° F./min. During the calcinations, the air flow was

adjusted at 5 volume/volume solid/minute. The sorbent contains 11.03 wt % expressed as Na₂O loading.

[0178] A series of samples containing different sodium loadings were also prepared similarly on γ-Al₂O₃ extrudates. The sodium contents in the sorbents as Na₂O are 3.01, 5.80, and 15.68 wt %, respectively.

Example 6—Sorbent Preparations

[0179] Additional samples of Na-based sorbents were prepared, including:

-Theta-Al₂O₃ extrudates were used to deposit Na₂CO₃. It has surface area of 126 m²/g, 0.58 cm³/g pore volume and pore size of 143 Å. The sorbent contains 11.03 wt % Na₂O as loading.

-Alpha-Al₂O₃ extrudates were used to deposit Na₂CO₃. It has surface area of 0.8 m²/g, 0.46 cm³/g pore volume and pore size of 2.8 micron. The sorbent contains 5.80 wt % Na₂O as loading.

-Alpha- and Theta- mixture phase Al₂O₃ extrudates were used to deposit Na₂CO₃. It has surface area of 32 m²/g, 0.15 cm³/g pore volume and pore size of 155 Å. The sorbent contains 5.80 wt % Na₂O as loading.

—SiO₂ extrudates were also used to deposit Na₂CO₃. It has surface area of 178 m²/g, 0.86 cm³/g pore volume and pore size of 202 Å. The sorbent contains 11.03 wt % Na₂O as loading.

Example 7—Sorbent Preparation

[0180] The solution containing potassium nitrate was prepared by dissolving potassium nitrate in distilled H₂O. As an example of sample preparation, 80.867 g of potassium nitrate was dissolved in 100 g of distilled water. The total solution volume of KNO₃/H₂O was adjusted with distilled water to 133 ml. 200 g of gamma alumina extrudates were impregnated with the solution by incipient wetness. The sample was dried in air at 250° F. for 16 hrs and calcined in air at 1000° F. for 6 hrs. The sorbent contains 15.85 wt % K₂O

[0181] Other samples containing different potassium loadings were also prepared. The potassium contents in these sorbents expressed as K₂O are 4.50 and 8.60 wt %, respectively.

Example 8—Simulated Moving Bed

[0182] An example using eight contactors with three on combustion gas, four on steam, and one in purge is described below.

[0183] A bench-scale apparatus for demonstration of the process can be made from eight stainless steel beds. Each bed is made from a tubular enclosure with 3" outer diameter with 0.065" wall thickness by 4.5" long. Each bed holds 600 cc of the sorbent. Tests are run at near 1 atm pressure. The temperature range is 120 to 180° C. and the beds can be run so that they are maintained at near isothermal condition. For example the temperature of the beds can be between 150 and 165° C. during a full cycle including adsorption, regeneration and optional purge. The entire apparatus is maintained in a heated and insulated box at near isothermal conditions. Individual beds are not heated or cooled during cycling (e.g. not heated during regeneration, cooled during adsorption, etc). The gas hourly space velocity (GHSV) in this bench-scale apparatus is typically between 1000 to 3000 hr⁻¹ and in regeneration it is typically between 400 and 1000 hr⁻¹.

Multiple 3-way control valves are used to control how each bed cycles through the adsorption, regeneration and an optional purge cycle. Typical cycle times are 30 seconds to 150 seconds after which the gas flow switches to the next cycle step. The cycle times can be adjusted to achieve different capture rates.

[0184] A non-limiting example of a bed configuration is shown in FIG. 22. In this example, 3 beds operate in adsorption, 4 beds in regeneration and one bed as a purge bed. The purge step displaces one bed volume of regeneration gas back into the regeneration line and prevents CO₂ from the regeneration gas from being carried into flue outlet. The purge gas is then pushed back into the adsorber exhaust in the next cycle. Dry N₂ is used as the purge gas. With 3 beds running in adsorption, each individual bed (whether in series or parallel) operates in adsorption mode for a total time of 3 times cycle time. With 4 beds in regeneration, each individual bed spends a total time of 4 times cycle time in regeneration.

[0185] In this example, the gases flow through the adsorption and regeneration beds in series. With the beds in series, the flue gas travels through all three adsorber beds before exiting the system. Likewise when regeneration beds are configured in series, the regeneration steams flows through all the regeneration beds before existing the system.

[0186] Other examples of bed configurations that can be utilized for demonstration of this process in an 8 bed apparatus include but are not limited to 3 beds in adsorption and 5 beds in regeneration; 2 beds in adsorption, 4 beds in regeneration and 2 beds in purge (between regeneration & adsorption and between adsorption and regeneration cycles); and 2 beds in adsorption, 5 beds in regeneration and 1 bed in purge. The simulated flue gas can run through the beds in either series or parallel. The regeneration beds can also be configured in either series or parallel. It is preferred to run the regeneration beds in series.

[0187] Another example of the process operated in an 8 bed test apparatus with the configuration shown in FIG. 22 included a simulated coal flue gas is shown FIG. 23, for the feed stream and adsorber outlet, and a demonstrated recovery stream in FIG. 24 (Percent CO₂ (in steam) in regeneration outlet in multiple fixed bed apparatus for near 90% Capture case.) The simulated coal flue feed gas was 13.1% CO₂, 6% H₂O with the balance N₂. The process was operated at near 1 atm with GHSV in adsorption of 1040 hr⁻¹ and GHSV in regeneration of 550 hr⁻¹. The beds temperature was about 165° C. With a process cycle time of 110 s, the CO₂ loading was 0.88 wt % and 89.3% of the CO₂ was captured. The sorbent reduced the CO₂ concentration in the flue gas from 13% to 1.2%. The outlet CO₂ concentration in the regenerator is concentrated to 35% (with the balance steam (any N₂ present was not measured). Sorbent was prepared according to sorbent preparation Example 2.

[0188] In another example of the process operated in an 8 bed test apparatus with the configuration shown in FIG. 22, the adsorber data is shown in FIG. 25. The simulated coal flue gas was 13.0% CO₂ and 4.2% H₂O with the balance N₂. The process was operated at near 1 atm with GHSV in adsorption of 1410 hr⁻¹ and GHSV in regeneration of 420 hr⁻¹. The beds temperature was about 175° C. Under these conditions we are starving the process of steam during regeneration. The cycle rate was 80 s. The CO₂ in the outlet of regeneration is increasingly concentrated (>80% CO₂ in steam). The capture rate was 70% and the CO₂ dynamic

loading 0.72 wt % CO₂. Sorbent was prepared according to sorbent preparation Example 2.

Example 9—Cyclic Adsorption/Steam Displacement

[0189] Samples were tested in the form of extrudate pellets, generally 1/16" to 1/8" in diameter held in a cylindrical stainless steel vessel, approximately 1"×7.5" and heated with a band heater, generally in the range of 130–150° C. The loaded bed typically holds 30 to 60 grams of extrudates dependent on the bulk density of the adsorbents.

[0190] CO₂ containing feed is passed through the bed for adsorption at a flow rate of 1000 standard cubic centimeters per minute (scm). Steam flows are generated by flowing 0.3 cubic centimeters per minute of water through a length of heated 1/16" tubing, resulting in a steam flow rate of approximately 374 sccm.

[0191] CO₂ containing feed composition was 4% CO₂, 1% He, 8% H₂O, 8% O₂, and 79% nitrogen.

[0192] While bed temperatures rise and fall in accordance with net adsorption energies, both feed and steam are heated to approximately 140° C. to enable and overall isothermal cyclic process.

[0193] The cyclic experiment comprises passing CO₂ containing feed through the adsorbent extrudates bed until full breakthrough of the feed composition is determined, i.e. CO₂ concentration exiting the bed rises to its 4% concentration in the feed.

[0194] The adsorbent's capacity to adsorb CO₂ under the tested conditions is determined from the time from feed initiation the time when the CO₂ concentration rises to half the feed concentration. On the assumption of a symmetrical breakthrough front, this method closely approximates the amount of CO₂ that will be adsorbed when the bed is fully loaded. The above described time of adsorption is converted to a wt. % CO₂ capacity by multiplying by the CO₂ feed concentration and flow rate and dividing by the weight of adsorbent in the bed.

[0195] In the cyclic process, water is desorbed from the adsorbent as CO₂ is adsorbed. It is always observed that the bed temperature, as determined by the temperature of the gases exiting the bed, drops during CO₂ uptake. This "desorptive displacement phenomena" is in sharp contrast to simple single gas adsorption, where the energy released by adsorption causes the bed temperature to rise.

[0196] Following the full feed breakthrough described above, CO₂ containing feed is turned off and steam is introduced into the bed. As water is adsorbed on the bed and CO₂ is displaced, initially the void gases (non-adsorbed gases in the void volume within and without the extrudates) exit the reactor. Next, a high concentration "wave" of relatively dry CO₂ exits the bed. This "wave" has CO₂ concentrations >50% and often >75-80%, diluted typically by nitrogen and water vapor. The fact that CO₂ exits the bed at a concentration higher than that in the feed distinguishes this desorptive displacement process from more typical purge, or partial pressure desorption processes. Following the high concentration CO₂ wave, steam breaks through the bed, having completed its adsorption. It is always observed that upon the steam breakthrough that indicates that the water adsorption front has proceeded to the end of the bed, the temperature rises. This phenomena arises due to the

greater heat of adsorption released by water's adsorption as compared to the heat of desorption required for the CO₂'s release.

[0197] The adsorbent's water capacity is determined from the time from steam introduction to the time following the "CO₂ wave" whereupon high concentration steam breaks through the bed.

[0198] The graphical data in FIG. 26 was typical for the experimental results and indicated the critical adsorption periods for this cyclic displacement process. This particular graphical representation was taken within a cyclic run of Sorbent A, discussed below.

Example 10—Effect of Water in the CO₂ Containing Feed

[0199] The properties of one formulation of sorbent are shown below. This sorbent was fabricated by extrusion, which provides a relatively high crush strength. The sorbent is very porous and has a moderately high surface area. Although the theoretical loading is high (9%), the dynamic loading under the expected operating conditions is relatively low (0.4% to 1.0 wt %). This sorbent was employed in a number of adsorption/regeneration cycles using simulated combustion gas (13.8% CO₂) with varying water concentrations. The results, illustrated below, show that at 9% water the working capacity is reduced to 92% of that for zero water and that doubling the water concentration to 18% only reduces the working capacity to 85% of the zero water value. The loading values in FIG. 27 are normalized by the zero water loading for each temperature.

[0200] A sample of sorbent prepared according to Sorbent Preparation Example 4 was employed in a series of adsorption/regeneration cycles using simulated combustion gases containing 6% CO₂ by volume, and having water concentrations ranging from zero to 28.5 vol %. The results, illustrated in FIG. 28, show that even at the very high concentration of water the working capacity for CO₂ was still more than half the capacity obtained at zero water.

Example 11—Preparation and Testing of Sorbents A-I

[0201] Sorbent A: 13.5 wt. % K on Gamma Alumina Extrudates: γ -Al₂O₃ extrudates were used as support to deposit K₂CO₃. It has a surface area of 306 m²/g, pore volume of 0.85 cm³/g, and pore size centered on 73 Å. The solution containing potassium carbonate was prepared by dissolving potassium carbonate in distilled H₂O. As an example of the sample preparation, 27.6353 g of potassium carbonate was dissolved in 60 g of distilled water. The total solution volume of K₂CO₃ was adjusted with distilled water to 86 ml. 100 g of gamma alumina extrudates were impregnated with the potassium carbonate solution by incipient wetness. The sample was dried in air at 250° F. for 16 hrs. The K loading is defined as weight of K/(weight of K+weight of alumina).

[0202] Sorbent B: 13.5 wt. % K on Theta Alumina Extrudates: θ -Al₂O₃ extrudates were used to deposit potassium citrate. It has surface area of 126 m²/g, pore volume of 0.58 cm³/g, and pore size of 143 Å. The solution containing potassium citrate was prepared by dissolving potassium citrate tribasic monohydrate (C₆H₅K₃O₇·H₂O) in distilled H₂O. As an example of the sample preparation, 64.866 g of potassium citrate tribasic monohydrate was dissolved in 100

g of distilled water. The total solution volume of potassium citrate was adjusted with distilled water to 92 ml. 150 g of theta alumina extrudates were impregnated with the potassium citrate solution by incipient wetness. The sample was dried in air at 250° F. for 16 hrs. The sample was then placed in a box furnace which was purged with nitrogen flow for 1 hr before 54 calcinations. The furnace was ramped at rate of 10° F./min from room temperature to 1000° F. (538° C.) under nitrogen flow and stayed at 1000° F. (538° C.) under nitrogen for 3 hrs. The furnace was cooled down in nitrogen flow to room temperature. The nitrogen flow during calcinations steps was adjusted at 5 volume/volume solid/minute.

[0203] Sorbent C: 7.2 wt. % K on Theta Alumina Extrudates: The same θ -Al₂O₃ extrudates as in the Example B were used for deposition of potassium citrate. The solution containing potassium citrate was prepared by dissolving potassium citrate tribasic monohydrate (C₆H₅K₃O₇·H₂O) in distilled H₂O. As an example of the sample preparation, 32.4035 g of potassium citrate tribasic monohydrate was dissolved in 100 g of distilled water. The total solution volume of potassium citrate was adjusted with distilled water to 92 ml. 150 g of theta alumina extrudates were impregnated with the potassium citrate solution by incipient wetness. The sample was dried in air at 250° F. for 16 hrs. The sample was then placed in a box furnace which was ramped at rate of 10° F./min from room temperature to 1000° F. (538° C.) in air flow and stayed at 1000° F. (538° C.) in air for 3 hrs. The air flow during calcinations was adjusted at 5 volume/volume solid/minute.

[0204] Sorbent D: Sorbent D is equivalent to the sorbent preparation of Example 2 above.

[0205] Sorbent E: 7.2 wt. % K on Carbon Extrudates: Carbon extrudates were used to deposit potassium hydroxide. It has surface area of 1491 m²/g, pore volume of 0.73 cm³/g, and pore size of 46 Å. The solution containing potassium hydroxide was prepared by dissolving potassium hydroxide in distilled H₂O. As an example of the sample preparation, 5.6046 g of potassium hydroxide (KOH) was dissolved in 30 g of distilled water. The total solution volume of potassium citrate was adjusted with distilled water to 42 ml. 50 g of carbon extrudates were impregnated with the potassium hydroxide solution by incipient wetness. The sample was dried in air at 250° F. for 16 hrs.

[0206] Sorbent F: 7.2 wt. % K on Theta Alumina Extrudates: The same θ -Al₂O₃ extrudates as in the Example B were used for deposition of potassium carbonate. The solution containing potassium carbonate was prepared by dissolving potassium carbonate in distilled H₂O. As an example of the sample preparation, 13.805 g of potassium carbonate (K₂CO₃) was dissolved in 40 g of distilled water. The total solution volume of K₂CO₃ was adjusted with distilled water to 62 ml. 100 g of theta alumina extrudates were impregnated with the solution by incipient wetness. The sample was dried in air at 250° F. for 16 hrs.

[0207] Sorbent G: 13.5 wt. % K on Gamma Alumina Extrudates: The same γ -Al₂O₃ extrudates as in the Example A were used for deposition of potassium citrate. The solution containing potassium citrate was prepared by dissolving potassium citrate tribasic monohydrate (C₆H₅K₃O₇·H₂O) in distilled H₂O. As an example of the sample preparation 86.488 g of potassium citrate tribasic monohydrate was dissolved in 120 g of distilled water. The total solution volume of potassium citrate was adjusted with distilled water to 173 ml. 200 g of gamma alumina extrudates were

impregnated with the potassium citrate solution by incipient wetness. The sample was dried in air at 250° F. for 16 hrs. The sample was then placed in a box furnace which was ramped at rate of 10° F./min from room temperature to 1000° F. (538° C.) in air flow and stayed at 1000° F. (538° C.) in air for 3 hrs. The air flow during calcinations was adjusted at 5 volume/volume solid/minute.

[0208] Sorbent H: 7.2 wt. % K on Theta Alumina Extrudates: The same θ - Al_2O_3 extrudates as in the Example B were used for deposition of potassium citrate. The solution containing potassium citrate was prepared by dissolving potassium citrate tribasic monohydrate ($\text{C}_6\text{H}_5\text{K}_3\text{O}_7 \cdot \text{H}_2\text{O}$) in distilled H_2O . As an example of the sample preparation, 64.807 g of potassium citrate tribasic monohydrate was dissolved in 180 g of distilled water. The total solution

[0210] Cyclic Adsorption Capacity Determinations for Sorbents a Through I

[0211] The following Table shows the measured adsorbent capacities for CO_2 , H_2O , and the CO_2 ratio for a number of non-limiting adsorbent preparations. We have found that various supports for the alkali metals can all be effective. Further, we have found that addition of the alkali to a formed extrudates or pellet or can be added to the base support material and later formed into the desired sphere, extrudates, or pellet form can be done by most methods known to those skilled in the art. Below, we demonstrate adsorbents composed of either potassium or sodium, added as either carbonates or bicarbonates, hydroxides, or as organometallic species (the non-limiting example of potassium citrate is shown that is then calcined or pyrolyzed).

Table of Cyclic Displacement Adsorbent Capacities

| | | % CO_2 | % H_2O | $\text{H}_2\text{O}/\text{CO}_2$ Mole Ratio | Added As |
|-----------|--|-----------------|------------------------|--|---|
| Sorbent A | 13.5 wt. % K on Gamma Alumina Extrudates | 1.09 | 1.98 | 4.4 | Potassium Carbonate |
| Sorbent B | 13.5 wt. % K on Theta Alumina Extrudates | 0.85 | 1.08 | 3.1 | Potassium citrate-pyrolyzed in N_2 |
| Sorbent C | 7.2 wt. % K on Theta Alumina Extrudates | 0.78 | 1.87 | 5.9 | Potassium Citrate-calcined |
| Sorbent D | 9 wt. % Na extruded on Boehmite and Calcined | 0.76 | 2.1 | 6.8 | Sodium Bicarbonate |
| Sorbent E | 7.2 wt. % K on Carbon Spheres | 0.77 | 2.72 | 8.6 | KDH |
| Sorbent F | 7.2 wt. % K on Theta Alumina Extrudates | 0.53 | 1.73 | 8.0 | Potassium Carbonate |
| Sorbent G | 13.5 wt. % K on Gamma Alumina Extrudates | 1.48 | 3.5 | 5.8 | Potassium Citrate-calcined |
| Sorbent H | 7.2 wt. % K on Theta Alumina Extrudates | 0.68 | 7.73 | 6.2 | Potassium Citrate-calcined |
| Sorbent I | 12.1 wt. % Na on Gamma Alumina Extrudates | 1.04 | 2.79 | 6.6 | Sodium Carbonate |

volume of potassium citrate was adjusted with distilled water to 185 ml. 300 g of theta alumina extrudates were impregnated with the potassium citrate solution by incipient wetness. The sample was dried in air at 250° F. for 16 hrs. The sample was then placed in a box furnace which was ramped at rate of 10° F./min from room temperature to 1000° F. (538° C.) in air flow and stayed at 1000° F. (538° C.) in air for 3 hrs. The air flow during calcinations was adjusted at 5 volume/volume solid/minute.

[0209] Sorbent I: 12.1 wt. % Na on Gamma Alumina Extrudates: The same γ - Al_2O_3 extrudates as in the Example A were used for deposition of sodium carbonate. The solution containing sodium carbonate was prepared by dissolving sodium carbonate in distilled H_2O . As an example of sample preparation, 15.90 g of sodium carbonate was dissolved in 25 g of distilled water. The total solution volume of Na_2CO_3 was adjusted with distilled water to 43 ml. 50 g of gamma alumina extrudates were impregnated with the sodium carbonate solution by incipient wetness. The sample was dried in air at 250° F. for 16 hrs. The sample was then placed in a box furnace which was ramped at rate of 10° F./min from room temperature to 1000° F. (538° C.) in air flow and stayed at 1000° F. (538° C.) in air for 3 hrs. The air flow during calcinations was adjusted at 5 volume/volume solid/minute.

[0212] Note that Sorbent E was tested without the presence of air as it was observed that carbon gasification was taking place. It is suggested that carbon supported adsorbents useful in this process are best used in anaerobic conditions such as those found in natural gas CO_2 removal processes.

Example 12— CO_2 Loading Capacities

[0213] Alkalized sorbents for the disclosure can be assessed for CO_2 loading capacities. Isothermal testing was conducted to measure the ultimate loading capacities of different sets of alkalized supports. Tests were conducted across several % wt alkali compositions, and the results of shown in FIGS. 29A and 29B.

Example 13—8 Bed Simulated Moving Bed System with Adsorption Run in Parallel

[0214] An 8-bed simulated moving bed system was constructed in which the adsorption zone of the system included beds run in parallel rather than in series. An exemplary diagram is shown in FIG. 30. The bench scale apparatus was run as previously described, monitoring the CO_2 in flue gas feed, the breakthrough of CO_2 at the adsorbers outlet, and the CO_2 at the regeneration outlet. Beds were operated in a

2:6, 3:5, and 4:4 adsorb:regeneration sequence. Results are set forth in the Table 5, with figures for the CO₂ levels shown in FIGS. 31-33, as noted in the table.

| Adsorb:Regen Bed Ratio | Loading levels of CO ₂ | Capture percentage | Associated figures |
|---------------------------|--------------------------------------|-----------------------|-----------------------|
| 2:6 | 0.82 wt % | 88.3% | FIG. 31 |
| 3:5 | 0.83 wt % | 90.3% | FIG. 32 |
| 4:4 | 0.83% | 88.7% | FIG. 33 |

Example 14—10 Bed Simulated Moving Bed System with Optional Recycle Streams

[0215] A 10-bed simulated moving bed system was constructed in which the adsorption zone of the system included beds run in parallel rather than in series. An exemplary diagram is shown in FIG. 34A to 34D.

Example 15—10 Bed Simulated Moving Bed System with Optional Steam Saver

[0216] A 10-bed simulated moving bed system can be constructed that demonstrates a steam saver method at a commercial level, as shown in FIGS. 35A-35D. The method can address unsteady flows and segregate the steam saver effluent from the regen effluent. The flue gas can be split across 4 beds, in parallel, with the bed just coming on adsorption getting $\frac{1}{4}$ of the total flow, and the other three getting $\frac{3}{4}$ each. The effluent from the first bed on adsorption can be directed to the bed that just left adsorption and the effluent from that bed can go to vent (recycle), leading to approximately 14% of the flue gas being diverted to steam saving, and equivalent to diverting one of three beds for 43% of a cycle (38 seconds out of 90). The method can eliminate mixing steam saver gas with regen gas, and reduce need for a means to accommodate uneven flows during steam saver steps, such as via surge vessels. The reduced rate of flow during steam saving can reduce pressure drop so that the flue gas can flow through the two beds (one generating steam saving gas and the other re-adsorbing the saved steam) in series with the same or a little bit less pressure drop than the beds feeding the $\frac{3}{4}$ of the flue gas each, eliminating the need for a possible no steam saver blower.

EMBODIMENTS

[0217] Additionally or alternately, the disclosure can include one or more of the following embodiments.

Embodiment 1

[0218] A sorbent comprising a support and a metal compound selected from the group consisting of alkali and alkaline earth.

Embodiment 2

[0219] A CO₂ adsorption sorbent comprising a support and a metal compound selected from the group consisting of alkali and alkaline earth.

Embodiment 3

[0220] A carbon dioxide-water equilibrium adsorption surface, comprising metal compound adhered to the surface of a support, wherein the surface adsorbs carbon dioxide and

desorbs water in a CO₂-water atmosphere having less than 35 wt % water, and desorbs carbon dioxide and adsorbs water in a CO₂-water atmosphere having greater than 60 wt % water.

Embodiment 4

[0221] A CO₂ adsorption sorbent comprising a support; a metal compound comprising Li, Na, K, Rb, Cs, Be, Mg, Ca, Sr, or Ba, or a combination thereof; and adsorbed carbon dioxide, wherein the metal compound is at least 5 wt % of the sorbent, and the adsorbed carbon dioxide is at least 0.7 wt %.

Embodiment 5

[0222] A sorbent comprising a metal compound and a support, wherein the sorbent will adsorb carbon dioxide from a wet atmosphere.

Embodiment 6

[0223] An adsorption-desorption sorbent comprising a metal compound and a support, wherein the sorbent has a carbon dioxide capacity of at least about 0.5 wt %, a water capacity of at least about 1 wt %, and a water/carbon dioxide selectivity that varies with the relative concentration of the two sorbates in the environment above the sorbent.

Embodiment 7

[0224] A method of making a sorbent comprising treating a support with a solution consisting essentially of a metal complex and a solvent, and drying the sorbent.

Embodiment 8

[0225] A method of making a sorbent comprising preparing pellets of a support by mixing the support in water, drying, and firing at least at about 300° C., mixing the pellets in an aqueous solution comprising water and a metal complex to prepare a pre-sorbent, drying the pre-sorbent at a temperature of at least 120° C. 42.

Embodiment 9

[0226] A method of making a sorbent comprising admixing a support in an aqueous slurry containing the alkali or alkaline metal complex and forming the slurry into an extrudate or pellet, and calcining to at least 300° C.

Embodiment 10

[0227] The method of any of the previous embodiments, further comprising calcining the dried pre-sorbent at a temperature of at least about 400° C., or calcining the sorbent at a temperature of at least about 400° C. in an air flow of at least about 3 volume/volume solid/minute.

Embodiment 11

[0228] The method of any of the previous embodiments, wherein the support has a known pore volume, and the support is treated with an approximately equal volume of the metal solution.

Embodiment 12

[0229] The method of any of the previous embodiments, wherein the sorbent consists essentially of the support, a

metal compound derived from the calcined metal complex, and any associated counterions.

Embodiment 13

[0230] The method of any of the previous embodiments, wherein the additional alkali or alkaline metal species is added to the formed alkalized support pellet by impregnation from an aqueous solution.

Embodiment 14

[0231] The sorbent or method of any of the previous embodiments, wherein the metal compound comprises Li, Na, K, Rb, Cs, Be, Mg, Ca, Sr, or Ba, or a combination thereof; comprises Li, Na, K, Mg, or Ca, or a combination thereof; or Na or K.

Embodiment 15

[0232] The sorbent or method of any of the previous embodiments, wherein the metal compound is at least 5 wt % of the sorbent, at least 7 wt % of the sorbent, or at least 10 wt % of the sorbent.

Embodiment 16

[0233] The sorbent or method of any of the previous embodiments, wherein the support comprises alumina, titania, zirconia, silica, clay, carbon, and mixtures there, or alumina.

Embodiment 17

[0234] The sorbent or method of any of the previous embodiments, wherein the support has a surface area of at least about 100 m²/g, at least about 200 m²/g.

Embodiment 1

[0235] The sorbent or method of any of the previous embodiments, wherein the metal complex is an organometallic complex, or wherein the metal complex is an acetate or citrate complex with alkali or alkaline metal, or wherein the metal complex is an acetate or citrate complex with Na or K.

Embodiment 18

[0236] The sorbent or method of any of the previous embodiments, wherein the sorbent will adsorb the carbon dioxide from the wet atmosphere having up to 35 wt % water, or will adsorb the carbon dioxide and desorb water in a wet atmosphere having up to 35% water or less.

Embodiment 19

[0237] The sorbent or method of any of the previous embodiments, wherein the sorbent will adsorb carbon dioxide after the sorbent has been saturated with water at a partial pressure of 1 bar.

Embodiment 20

[0238] The sorbent or method of any of the previous embodiments, wherein the sorbent previously loaded with

carbon dioxide will desorb carbon dioxide from the sorbent in an atmosphere that is greater than 35% water.

Embodiment 21

[0239] The sorbent or method of any of the previous embodiments, wherein the sorbent will desorb carbon dioxide from the sorbent previously loaded with carbon dioxide at a partial pressure of 0.02 to 1.0 bar.

Embodiment 22

[0240] The sorbent or method of any of the previous embodiments, wherein the ratio of carbon dioxide and water on the support varies with the relative concentration of the two sorbates in the environment above the sorbent.

Embodiment 23

[0241] The sorbent or method of any of the previous embodiments, wherein the sorbent desorbs CO₂ in the presence of greater than 60% water vapor.

Embodiment 24

[0242] The sorbent or method of any of the previous embodiments, wherein the sorbent has a carbon dioxide capacity of at least about 0.5%, at least about 0.7 wt %, or at least about 1.0 wt %.

Embodiment 25

[0243] The sorbent or method of any of the previous embodiments, wherein the sorbent has a water capacity of at least about 1.0 wt %, at least about 1.5 wt %, or at least about 2 wt %.

[0244] It is to be understood that the embodiments and claims disclosed herein are not limited in their application to the details of construction and arrangement of the components set forth in the description and illustrated in the drawings. Rather, the description and the drawings provide examples of the embodiments envisioned. The embodiments and claims disclosed herein are further capable of other embodiments and of being practiced and carried out in various ways. Also, it is to be understood that the phraseology and terminology employed herein are for the purposes of description and should not be regarded as limiting the claims.

[0245] Accordingly, those skilled in the art will appreciate that the conception upon which the application and claims are based can be readily utilized as a basis for the design of other structures, methods, and systems for carrying out the several purposes of the embodiments and claims presented in this application. It is important, therefore, that the claims be regarded as including such equivalent constructions.

We claim:

1. A CO₂ adsorption sorbent comprising a support and a metal compound selected from the group consisting of alkali and alkaline earth.

* * * * *