



US 20240091996A1

(19) **United States**

(12) **Patent Application Publication**
JUNGNICKEL et al.

(10) **Pub. No.: US 2024/0091996 A1**

(43) **Pub. Date: Mar. 21, 2024**

(54) **METHOD OF MANUFACTURING A CONNECTOR, HANDLE AND HEAD**

A61C 13/00 (2006.01)

B23B 31/107 (2006.01)

(71) Applicant: **The Gillette Company LLC**, Boston, MA (US)

(52) **U.S. Cl.**

CPC *B29C 45/006* (2013.01); *A46B 5/0095* (2013.01); *A61C 13/0006* (2013.01); *B23B 31/1071* (2013.01); *A46B 2200/1066* (2013.01); *B29K 2101/12* (2013.01)

(72) Inventors: **Uwe JUNGNICKEL**, Königstein (DE); **Jens ALINSKI**, Kelkheim (DE)

(21) Appl. No.: **18/524,201**

(22) Filed: **Nov. 30, 2023**

(57) **ABSTRACT**

Related U.S. Application Data

(60) Division of application No. 17/511,103, filed on Oct. 26, 2021, now Pat. No. 11,865,748, which is a continuation of application No. 16/272,943, filed on Feb. 11, 2019, now Pat. No. 11,400,627.

Foreign Application Priority Data

Feb. 9, 2018 (EP) 18156035.0
Feb. 1, 2019 (US) US2019/016216

Publication Classification

(51) **Int. Cl.**
B29C 45/00 (2006.01)
A46B 5/00 (2006.01)

A method for manufacturing a handle, a connector, and a head by injection molding at least a part of the handle having a distal end and a proximal end comprising a hollow portion opposite the distal end. At least a part of the connector having an outer lateral surface and a recess therein by injection molding with the recess forming a cavity within the connector. A spring-loaded ball-snap element is provided that with a ball and a spring configured to apply a radial force onto the ball. The spring-loaded ball-snap element is inserted into the cavity of the connector and the spring-loaded ball-snap element is fixed therein. At least a part of the head is injection molded. The connector is inserted into the hollow portion of the handle and the connector and fixed. The ball is extended slightly beyond the connector's outer lateral surface surrounding the ball.

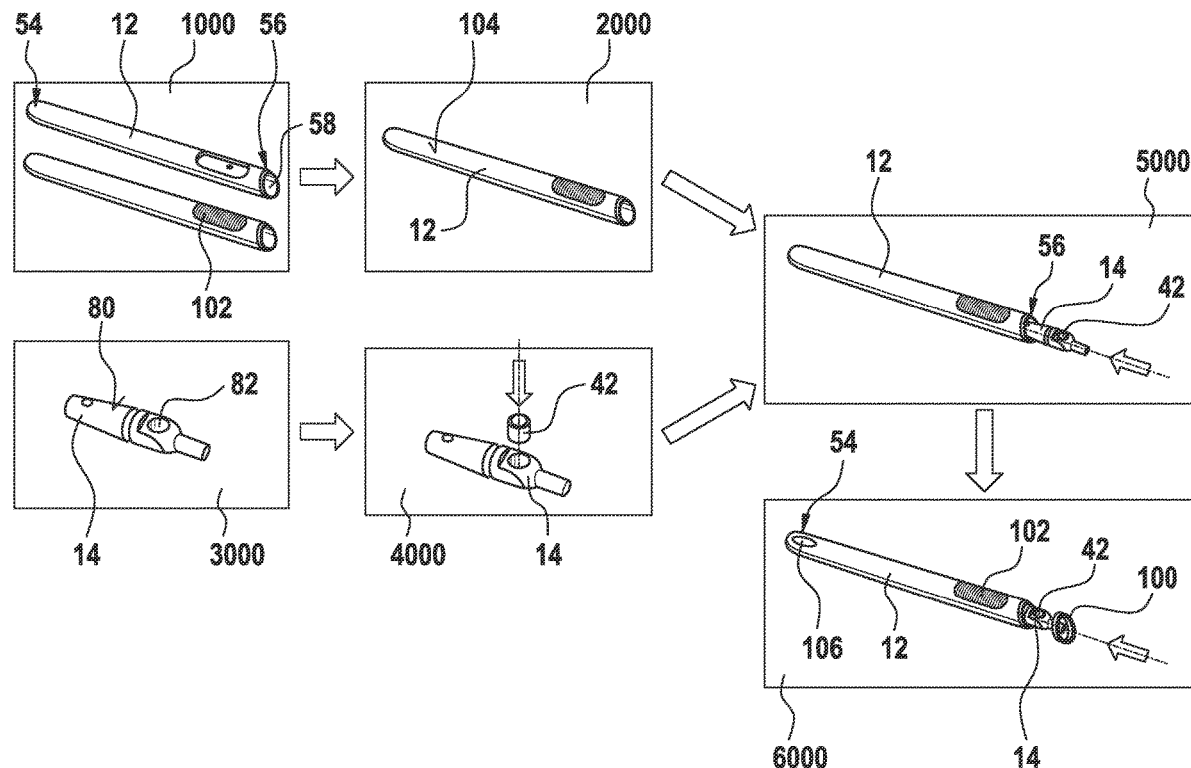

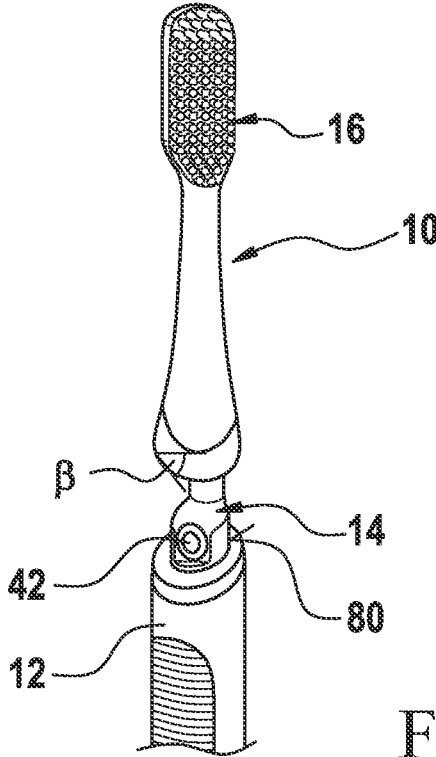

Fig. 1

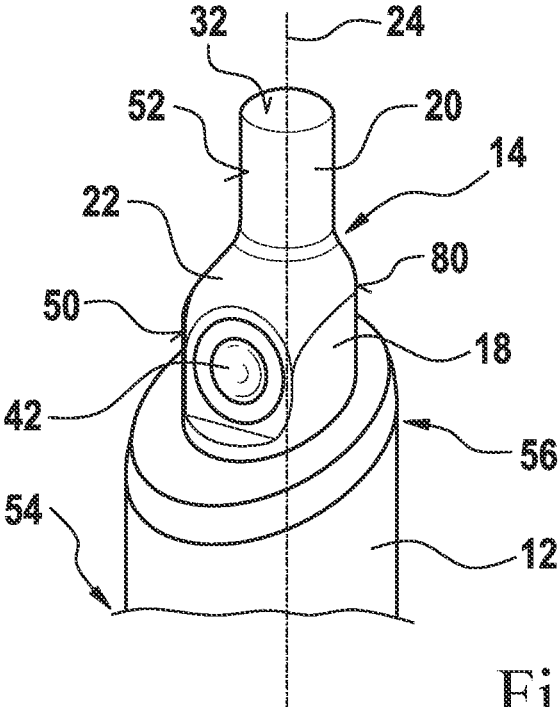

Fig. 2

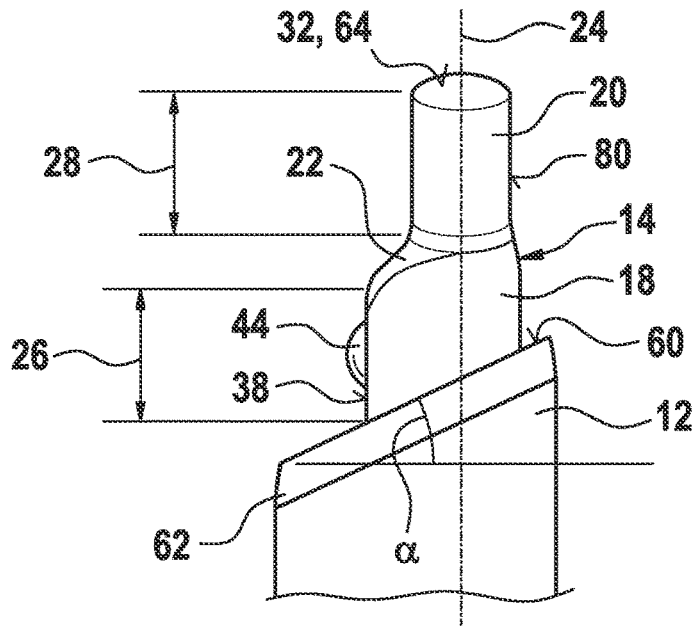

Fig. 3

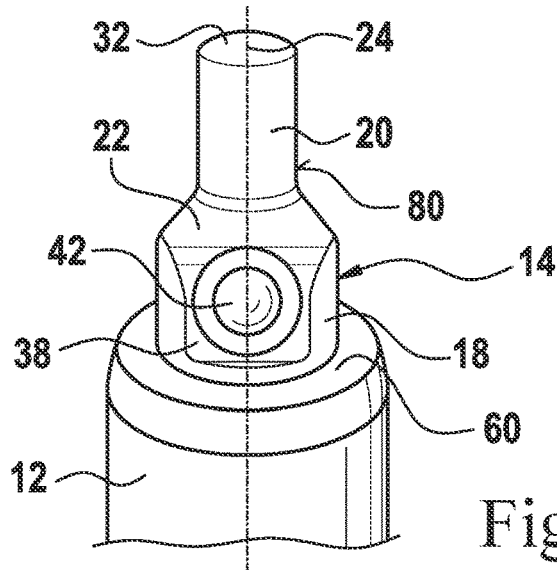

Fig. 4

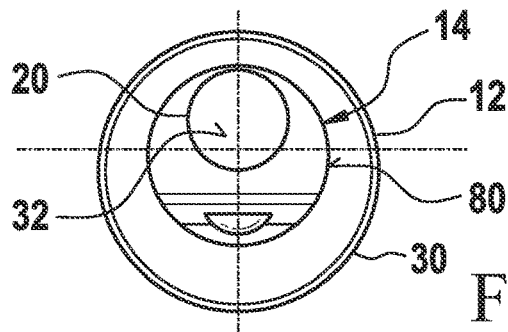

Fig. 5

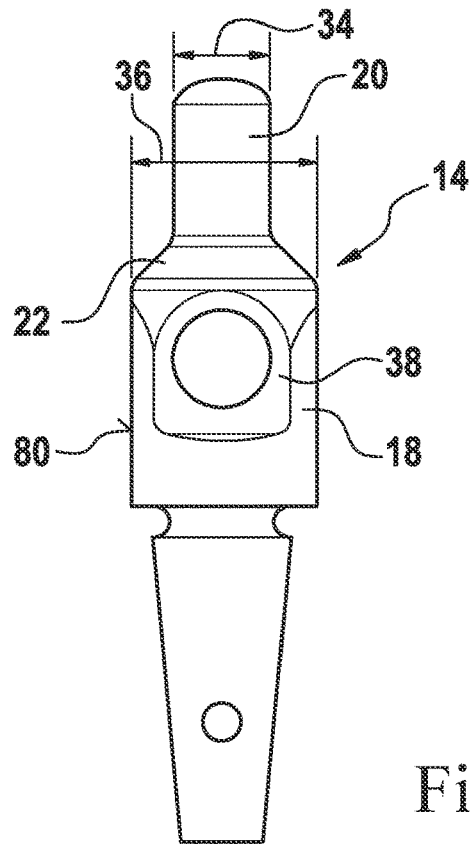

Fig. 6

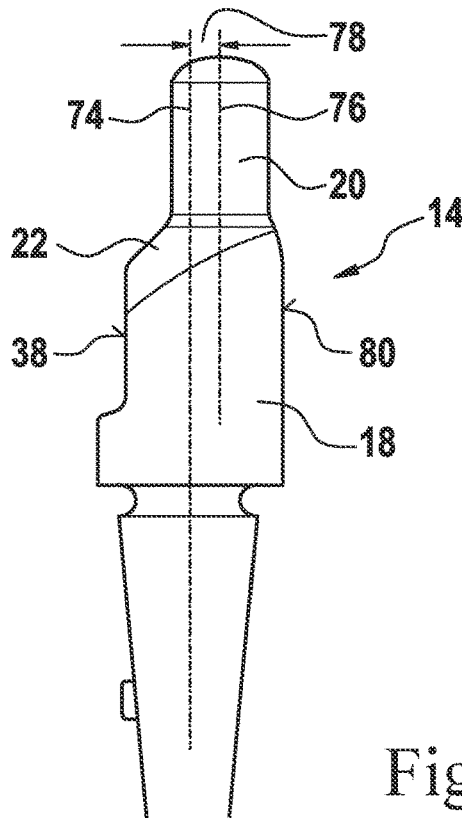

Fig. 7

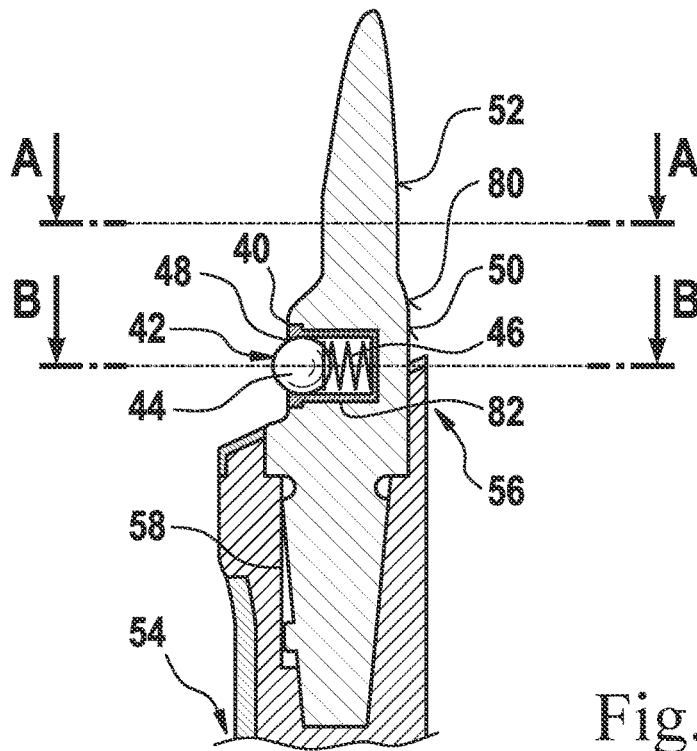

Fig. 8

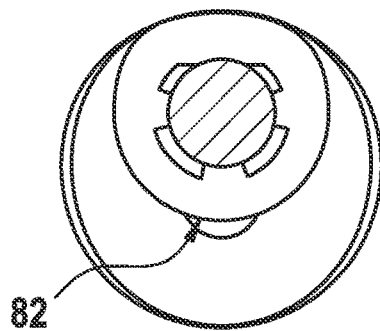

Fig. 9

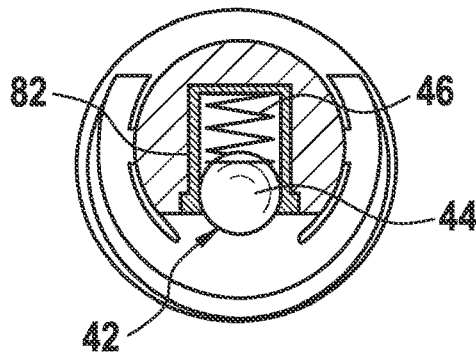

Fig. 10

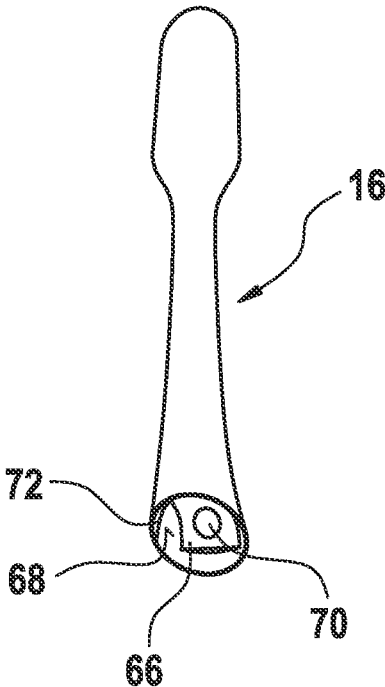

Fig. 11

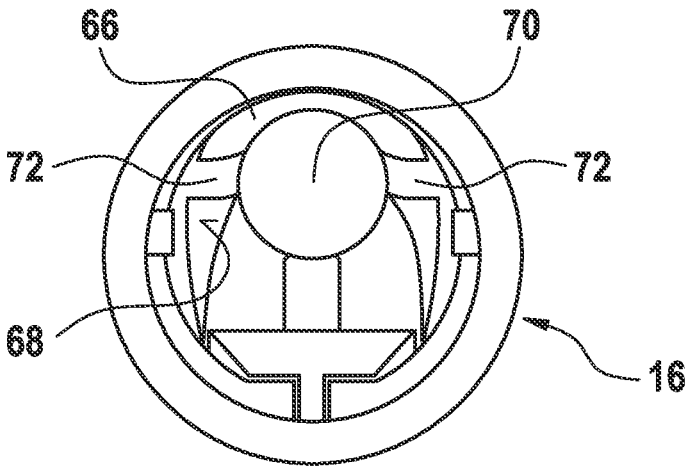

Fig. 12

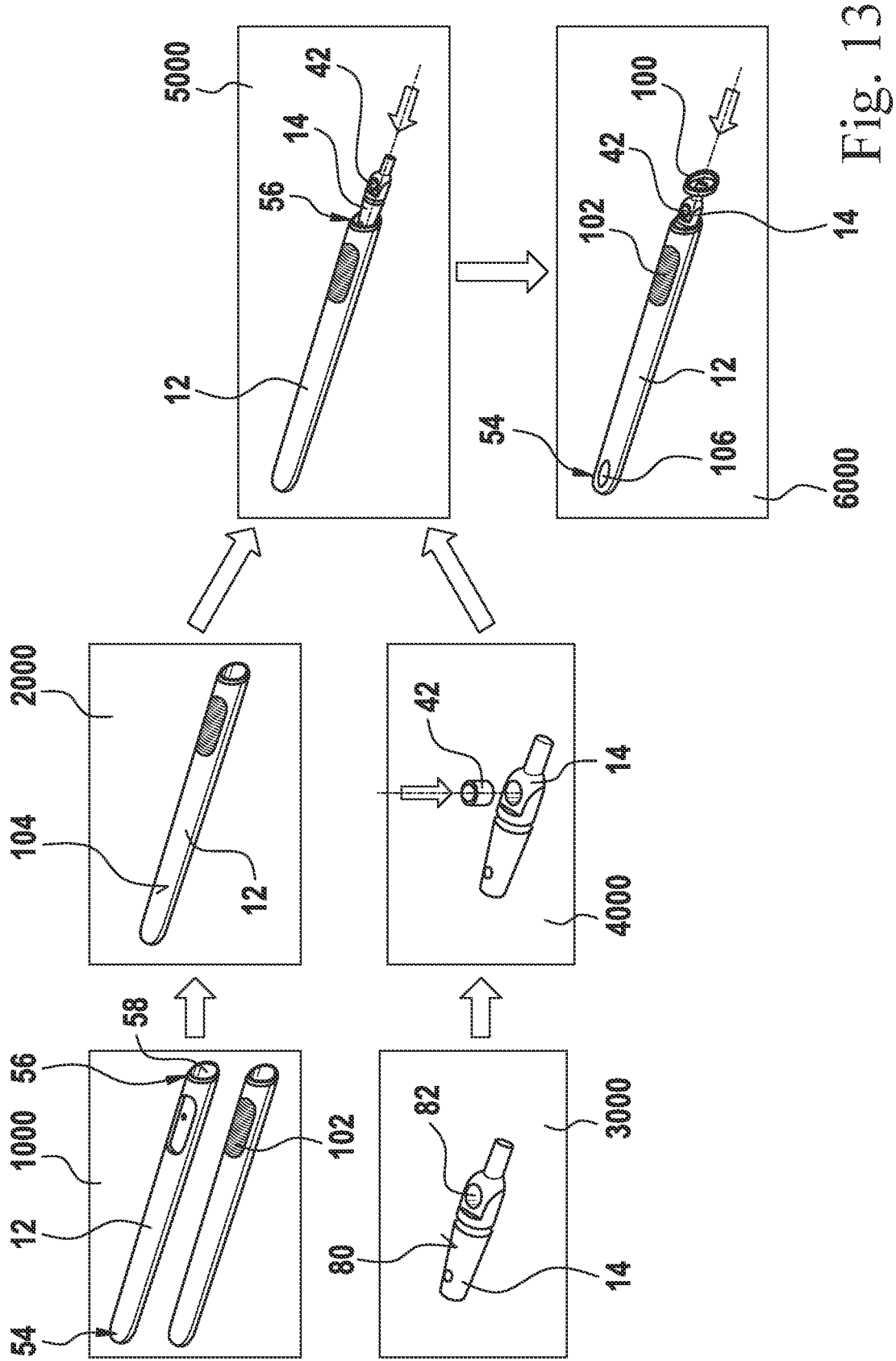

Fig. 13

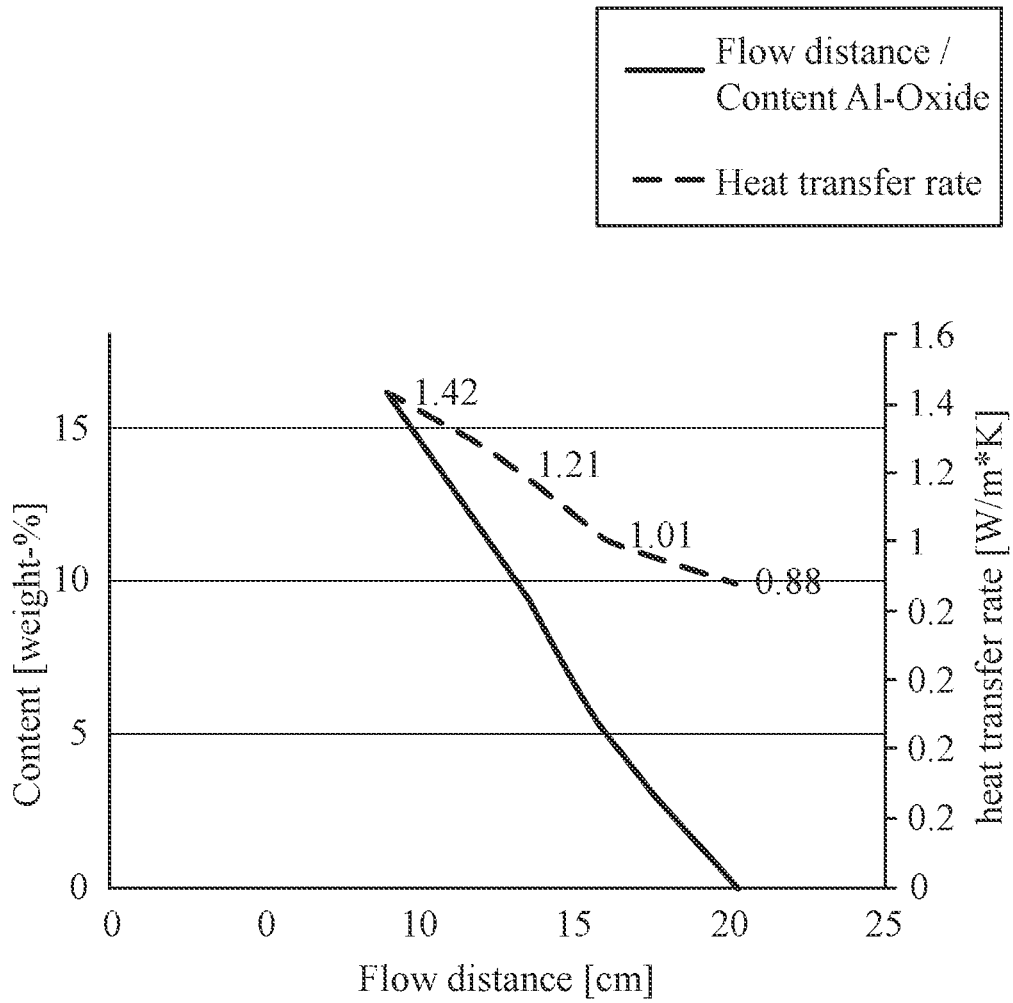

Fig. 14

METHOD OF MANUFACTURING A CONNECTOR, HANDLE AND HEAD

FIELD OF THE INVENTION

[0001] The present disclosure is concerned with a connector and a head, the head being repeatedly attachable to and detachable from a handle via the connector.

BACKGROUND OF THE INVENTION

[0002] Heads and handles for oral care implements, like manual toothbrushes, are well known in the art. Generally, tufts of bristles or other cleaning elements for cleaning teeth and soft tissue in the mouth are attached to a bristle carrier or mounting surface of the brush head intended for insertion into a user's oral cavity. The handle is usually attached to the head, which handle is held by a user during brushing. Usually, heads of manual toothbrushes are permanently connected to the handle, e.g. by injection molding the bristle carrier, the handle, a neck connecting the head and the handle, in one injection molding step. After the usual lifetime of a toothbrush, i.e. after about three months of usage, the toothbrush is discarded. In order to provide environmentally friendly/sustainable manual toothbrushes generating less waste when the brushes are discarded, manual toothbrushes are known comprising heads or head refills being exchangeable, i.e. repeatedly attachable to and detachable from the handle. Instead of buying a completely new toothbrush, consumers can re-use the handle and buy a new head refill only. Such refills are usually less expensive and generate less waste than a conventional manual toothbrush.

[0003] For example, manual toothbrushes are known comprising a handle to which a replaceable head is connected. The handle is provided with a cavity within which the head is insertable. To provide sufficiently strong connection between the head and the handle, the brush head is formed with a neck having a coupling anchor with a number of recesses for engaging in a complementary engaging mechanism within a collar of the handle.

[0004] However, such anchor/engaging mechanism has a relatively complex outer geometry which is not easy to clean after usage of the toothbrush. Toothpaste and slurry may accumulate in recesses of the anchor/engaging mechanism and may prevent the brush head to be accurately attachable to the handle. Further, such handle and head construction is not easy to manufacture in a cost-efficient manner.

[0005] Further, connector solutions featuring small plastic hooks that interact with respective apertures are known. However, these plastic hooks relax over time and the user needs to actively push back the hooks in parallel to pulling the refill in order to remove the brush head from the handle. Such connector solution is neither intuitive nor consumer friendly. Furthermore, such connectors are not easy to clean. Moreover, engaging parts provided in the brush refill are necessary which results in additional manufacturing costs and complexity.

[0006] It is an object of the present disclosure to provide a method for manufacturing an oral care implement in a cost-efficient and easy manner, in particular a method for manufacturing a manual toothbrush comprising a handle and a head, the head being repeatedly attachable to and detachable from the handle.

SUMMARY OF THE INVENTION

[0007] In accordance with one aspect a method for manufacturing an oral care implement is provided, the implement comprising a handle, a connector and a head, the head being repeatedly attachable to and detachable from the handle via the connector, the method comprising the following steps:

[0008] injection molding of at least a part of the handle, the handle having a distal end and a proximal end being opposite the distal end, the proximal end comprising a hollow portion;

[0009] injection molding of at least a part of the connector, the connector having an outer lateral surface and a recess therein, the recess forming a cavity within the connector,

[0010] injection molding of at least a part of the head,

[0011] inserting the connector into in the hollow portion of the handle, and fixing the connector, preferably by gluing, welding and/or press-fitting.

BRIEF DESCRIPTION OF THE DRAWINGS

[0012] The invention is described in more detail below with reference to various embodiments and figures, wherein:

[0013] FIG. 1 shows a perspective view of an example embodiment of a manual oral care implement according to the present disclosure, the oral care implement comprising a head, a handle and a connector;

[0014] FIG. 2 shows a perspective view of the handle with connector of FIG. 1;

[0015] FIG. 3 shows a schematic side view of the handle with connector according to FIG. 2;

[0016] FIG. 4 shows a schematic front view of the handle with connector according to FIG. 2;

[0017] FIG. 5 shows a schematic top-down view of the handle with connector according to FIG. 2;

[0018] FIG. 6 shows a front view of an example embodiment of a connector according to the present disclosure;

[0019] FIG. 7 shows a side view of the connector of FIG. 6;

[0020] FIG. 8 shows a longitudinal cross-sectional view of the handle with connector of FIG. 2;

[0021] FIG. 9 shows the cross-sectional view along line A-A;

[0022] FIG. 10 shows the cross-sectional view along line B-B;

[0023] FIG. 11 shows a schematic perspective view of the head of the manual oral care implement of FIG. 1;

[0024] FIG. 12 shows a bottom view of the head of FIG. 11; and

[0025] FIG. 13 shows a flow chart for manufacturing the handle comprising the connector of the oral care implement of FIG. 1; and

[0026] FIG. 14 is a graph showing average results of heat transfer and flow distance.

DETAILED DESCRIPTION OF THE INVENTION

[0027] The method for manufacturing an oral care implement according to the present disclosure comprises the following steps:

[0028] injection molding of at least a part of the handle, the handle having a distal end and a proximal end being opposite the distal end, the proximal end comprising a hollow portion;

- [0029] injection molding of at least a part of the connector, the connector having an outer lateral surface and a recess therein, the recess forming a cavity within the connector,
- [0030] injection molding of at least a part of the head,
- [0031] inserting the connector into in the hollow portion of the handle, and fixing the connector, preferably by gluing, welding and/or press-fitting.
- [0032] The oral care implement comprises a handle and a head on which at least one tooth and/or tissues cleaning element, e.g. a tuft of bristles and/or an elastomeric element, is fixed. The head is repeatedly attachable to and detachable from the handle. The oral care implement may be a manual toothbrush, or alternatively an inter-proximal pick, a plaque scraper or tissue/tongue cleanser. As the connector is fixed in and forms a part of the handle, the connector—representing a relatively expensive part of the overall oral care implement—can be used over an extended/longer period of time. The head—having a relatively simple structure and being relatively cheap as compared to the handle comprising the connector—can be replaced after usual time of usage, e.g. every three months. A new head refill can be purchased at relatively low costs. While replaceable brush heads according to the state of the art consist out of an assembly of multiple parts or comprise at least one additional insert, the frequently exchangeable brush heads for the oral care implement according to the present disclosure can be produced at lower costs.
- [0033] The method step for manufacturing the handle of the oral care implement may comprise:
- [0034] providing an amorphous thermoplastic resin,
- [0035] providing aluminum oxide, boron nitride or aluminum silicate,
- [0036] providing iron oxide,
- [0037] mixing the amorphous thermoplastic resin, aluminum oxide, boron nitride or aluminum silicate and iron oxide into a magnetic and/or ferromagnetic molding material,
- [0038] heating the molding material mixture into a flowable molding material, and
- [0039] molding the flowable molding mixture into a handle or part of a handle.
- [0040] The amorphous thermoplastic resin may comprise styrene acrylonitrile, polybutylene terephthalate and polyethylene terephthalate, wherein polybutylene terephthalate and polyethylene terephthalate may be premixed with glass fibers. The amorphous thermoplastic resin may be provided in a range from about 13 weight percent to about 30 weight percent; the aluminum oxide, boron nitride or aluminum silicate may be provided in a range from about 3 weight percent to about 25 weight percent; and the iron oxide may be provided in a range from about 45 weight percent to about 67 weight percent.
- [0041] The magnetic and/or ferromagnetic material may comprise about 17 weight percent of styrene acrylonitrile; about 10.5 weight percent of a composition comprising polybutylene terephthalate and polyethylene terephthalate; about 4.5 weight percent of glass fibers; about 17 weight percent of aluminum oxide; and about 51 weight percent of iron oxide.
- [0042] The material composition may be made by blending the amorphous thermoplastic resin with powder of aluminum oxide, boron nitride or aluminum silicate, and with iron oxide powder. Increasing the amount of iron oxide

within the material composition has further the advantage of providing a lower cost molding material because iron oxide powder is less expensive than the other filling agents. Amorphous thermoplastic resin, glass fibers, aluminum oxide/boron nitride or aluminum silicate powder, and iron oxide powder may be blended by using a uniaxial extruder, a biaxial extruder, a kneader, a Banbury mixer, a roll or other such extruders. After blending, the material is heated to become flowable. The flowable material may then be molded into a handle or part of a handle by injection molding.

[0043] The method for manufacturing the oral care implement may further comprise the following steps:

[0044] providing a spring-loaded ball-snap element, the element comprising a ball and a spring, the spring applying a radial force onto the ball,

[0045] inserting the spring-loaded ball-snap element into the cavity of the connector and fixing the connector, preferably by a press-fitting process, so that the spring applies a radial force onto the ball in a direction towards the outer lateral surface of the connector.

[0046] By providing a spring-loaded ball-snap element in the connector, the head of the oral care implement is attachable to the handle via a snap-fit locking mechanism to ensure sufficiently strong connection and stability between the head and the handle. The spring-loaded ball-snap element comprises a ball and a spring, the spring applying a radial force onto the ball in a direction towards the outer lateral surface of the connector. In the following a radial force is defined by a force applied in a direction being substantially perpendicular to the longitudinal length extension of the connector. In other words, the spring applies a force onto the ball and pushes the ball outwards so that the ball extends slightly beyond the outer lateral surface of the connector. The ball may engage with a recess provided in a hollow portion of the head when the head gets attached to the handle. Once the head is snap-fitted onto the connector, the head is fixed on the handle/connector in an axial direction. In other words, the connector and the oral care implement comprising such connector, respectively, allow for easy attachment/detachment of the head to and from the handle. The user can attach the brush head to the handle by a simple linear motion. Further, the ball-snap provides a precise fixation of the brush head, and a distinct haptic feedback is given to the user that the head is snapped-on securely. In other words, the user recognizes once the ball engages into the recess provided in the inner wall of the hollow portion of the head. The brush head can be easily removed, i.e. without performing a synchronized action with other elements/unlocking mechanisms.

[0047] The head may be fixed on the handle until a specific/predetermined pull-off force is applied. The connection between the head and connector is sufficiently strong enabling well-coordinated brushing techniques. The head may not get loosened from the handle and may not twist aside during brushing.

[0048] The ball and/or the spring of the spring-loaded ball element may be made from stainless steel. While typical snap elements comprise a spring element made from plastic that shows relaxation and aging effects over time, a stainless steel spring shows a constant spring rate over time, also under extended use conditions (e.g. temperature). A spring-loaded ball element made from stainless steel may provide long-lasting, reliable fixation of the head on the connector/

handle. Moreover, if the spring-loaded ball snap element is made completely from stainless steel, an electrical contact from the handle to the refill can be easily provided. In order to provide a closed electric circuit, an electrical conductive ring at the proximal end of the handle can be attached as a second contact. An electrical contact from the handle to the refill allows for various additional functions, e.g. light for diagnostics or treatment, e.g. for iontophoresis.

[0049] The spring-loaded ball element may be fixed in the cavity by a press-fitting process, welding and/or gluing which represents an easy and cost-efficient method.

[0050] In an additional step, the handle or part of the handle may be electroplated to add improved appearance and a pleasant feel. For example, by an electroplating step, the handle, or a part of the handle may be provided with a metal layer or coating, e.g. made from chrome, silver or gold to further improve the appearance of the handle.

[0051] Thermoplastic elastomers are also well suited for electroplating as they allow for the creation of both, hard and soft composite components to be electroplated selectively in one operation. Therefore, in addition, or alternatively, the handle may be electroplated with any additional material, for example a polyethylene material or a thermoplastic elastomer to create a soft region, e.g. a thumb rest. The soft region/thumb rest may improve the comfort and feel of the handle. Such thumb rest may provide the handle of the oral care implement with improved handling properties, e.g. with anti-slip properties to improve the maneuverability of the oral care implement under wet conditions, e.g. when the user brushes his teeth. The thumb rest may be made from thermoplastic elastomer having a Shore A hardness from about 30 to about 60, or about 40 to prevent the oral care implement from being too slippery when used in wet conditions. At least a portion of the thumb rest may have a concave shape with an angle α with respect to the area of the remaining portion of the thumb rest from about 20° to about 25°, or about 24°. The thumb rest or a gripping region may be attached onto the front surface of the handle in the region close to the proximal end, i.e. closest to the head. The thumb rest may comprise a plurality of ribs extending substantially perpendicular to the longitudinal axis of the oral care implement. Such ribs may allow users/consumers to use the oral care implement with even more control. The user/consumer can better grasp and manipulate the handle of the oral care implement during brushing. Such handle may provide further improved control and greater comfort during brushing, in particular under wet conditions.

[0052] The handle may be made from at least two, or at least three different materials, each forming different parts of the handle. For example, a first material, e.g. a magnetic and/or ferromagnetic material may be injection molded into a first component of the handle thereby forming an underlying base structure of the oral care implement. A second component, e.g. of polypropylene material may be injection molded over the first component, and/or a third component, e.g. of thermoplastic elastomer material may be injection molded over the first component and/or the second component.

[0053] The third component of thermoplastic elastomer material may form a thumb rest on the front surface of the oral care implement and/or a palm grip on the back surface being opposite the front surface to be gripped by the user's/consumer's fingers and thumb. Such handle configuration may even further resist slippage during use. The

thermoplastic elastomer material may extend through an aperture provided in the underlying base structure and/or second component of the handle.

[0054] The method for manufacturing the oral care implement may further comprise the following steps:

[0055] providing a ring,

[0056] attaching the ring onto the proximal end of the handle, preferably by gluing, welding and/or press-fitting. For example, the ring may be a metal layer surrounding the outer circumference of the handle. Such ring may serve as identification means.

[0057] The handle may be injection molded in a manner so that the proximal end of the handle has an upper surface being at least partially chamfered, and the chamfered upper surface and a cross-sectional area extending substantially perpendicular to the longitudinal axis of the handle define an angle α from about 15° to about 30°, or from about 18° to about 28°, or about 25°. Surprisingly, it has been found out that such angled/chamfered surface provides an anti-twist protection during brushing. In other words, if lateral forces are applied onto the brush head during brushing, the head may not easily twist aside. Furthermore, the angled/chamfered surface allows for draining-off fluids, like toothpaste slurry and saliva, after use of the oral care implement, thereby preventing accumulation of such fluids over time. The overall oral care implement can be kept clean over an extended period of time which renders the implement more hygienic.

[0058] Corresponding to the handle, the head may be manufactured and formed in a way that a proximal end of the head being opposite a distal end and closest to the handle when the head is attached thereto, has an upper surface which is chamfered, as well. The chamfered upper surface and the cross-sectional area of the head which is substantially perpendicular to the longitudinal axis of the head may define an angle β from about 15° to about 30°, or from about 18° to about 28°, or about 25°. Such configuration may allow for precise adjusting and fitting of the head onto the handle. The user can attach the head to the handle by a simple linear motion. With the chamfered surface of the handle and the corresponding chamfered surface of the head, the head is turned into the right orientation automatically during the attachment motion.

[0059] The connector may be injection molded in a manner so that at least a first substantially cylindrical section, a second substantially cylindrical section, and an at least partially conically shaped section connecting the first and the second cylindrical sections are formed, the first substantially cylindrical section, the at least partially conically shaped section and the second substantially cylindrical section are arranged in consecutive order along a longitudinal length extension, and the first substantially cylindrical section and the second substantially cylindrical section are placed off-center with respect to the longitudinal length extension.

[0060] In the following, a substantially cylindrical section is defined by a three-dimensional body having a longitudinal length extension and a cross-sectional area extending substantially perpendicular to the longitudinal length extension. The cross-sectional area has a shape being substantially constant along the longitudinal length extension. Since the connector may be manufactured by an injection molding process, a substantially cylindrical section also comprises sections/bodies which have a slight draft angle of up to 2°,

or up to 1°. In other words, a substantially cylindrical section also comprises a section/body which tapers slightly by up to 2°, or up to 1° towards a proximal end which is closest to the head once the head is attached to the connector.

[0061] The cross-sectional area may have any shape, for example substantially circular, ellipsoid, rectangular, semi-circular, circular with a flattening portion, convex or concave. The cross-sectional area may have the shape of a polygon, for example of a square or triangle. The outer lateral surface circumventing the cylinder along its length extension can be defined as being composed of straight lines which are substantially parallel with respect to the longitudinal length extension of the cylinder.

[0062] The proximal end of the head may comprise a hollow portion for receiving a part of the connector, for example, the second substantially cylindrical section, the at least partially conically shaped section and a part of the first substantially cylindrical section. The hollow portion of the head may be formed with an inner wall having a geometry/contour which corresponds to the outer geometry/contour of the part of the connector to be inserted into the hollow portion of the head. The eccentric arrangement/off-center positioning of the substantially cylindrical sections of the connector enables precise positioning of the brush head on the handle. The geometric position of the head can be clearly defined. As the handle comprises the connector at a proximal end being closest to the head, the eccentric/off-center arrangement of the two substantially cylindrical sections may act as a guidance element when a user attaches the head to the handle. In other words, the two substantially cylindrical sections may allow for accurate fitting between the head and the handle. Further, the eccentric/off-center arrangement of the two substantially cylindrical sections may provide an anti-twist protection for the head on the handle during brushing, for example if a lateral force is applied onto the head.

[0063] The first substantially cylindrical section and the second substantially cylindrical section may be formed with a length extension and a cross-sectional area extending substantially perpendicular to the length extension, and the cross-sectional area of the first substantially cylindrical section and/or second of the second substantially cylindrical section may be substantially circular. Such geometry provides a robust and simple structure which is easy to clean after usage of the oral care implement. Further, since the outer geometry is relatively simple, such connector can be manufactured in a cost-efficient manner.

[0064] The first substantially cylindrical section may be formed with a cross-sectional area being greater than the cross-sectional area of the second substantially cylindrical section. For example, the first substantially cylindrical section to be inserted into a hollow portion at the proximal end of the handle, may have a substantially circular cross-sectional area with a diameter of about 8 mm to about 10 mm, preferably about 9 mm, while the second substantially cylindrical section to be inserted into a hollow portion at the proximal end of the head, may have a substantially circular cross-sectional area with a diameter of about 4 mm to about 6 mm, preferably about 5 mm.

[0065] The first and the second substantially cylindrical sections may have a first and a second longitudinal central axis, respectively which are defined as the symmetry axis of the first and the second substantially cylindrical sections. The first and the second substantially cylindrical sections

may be formed with respect to each other so that the second longitudinal central axis of the second cylindrical section is located off-center with respect to the first longitudinal central axis of the first cylindrical section by about 1 mm to about 2.5 mm, or by about 1.5 mm to about 2 mm, or by about 1.65 mm. Such connector may be easy to manufacture by injection molding, and provides sufficient torsional stability for the oral care implement if lateral forces are applied onto the brush head.

[0066] The first and/or the second substantially cylindrical section may be formed with a flattening portion extending along the length extension of the first and/or second substantially cylindrical section. Such flattening portion may provide the toothbrush with additional anti-twist protection for the head being connected to the handle during brushing, for example if a lateral force is applied onto the head.

[0067] The first and the second substantially cylindrical sections have a first and a second outer surface, respectively, and the first and the second substantially cylindrical sections may be formed with respect to each other so that a part of the first outer surface and a part the second outer surfaces are substantially in straight alignment. The flattening portion, optionally comprising the spring-loaded ball element, may be arranged opposite the first and second outer surfaces being substantially in straight alignment. Such connector has an easy to clean outer geometry. The connector is robust, easy to use, and can be manufactured in a cost-efficient manner.

[0068] The connector and the oral care implement comprising such connector, respectively, allow for easy attachment/detachment of the head to and from the handle. The user can attach the head to the handle by a simple linear motion. With the specific design of the substantially cylindrical sections being formed off-center, and the chamfered surface of the handle, the head is turned into the right orientation automatically during the attachment motion (within certain tolerances). Therefore, the consumer is not forced to precisely position the head on the handle before snapping it on. Further, the ball-snap provides a precise fixation of the brush head, and a distinct haptic feedback is given to the consumer that the head is snapped-on securely. The brush head can be easily removed, without any synchronized action with other elements (unlocking mechanisms). In addition, the connector can be cleaned easily. The specific design of the connector may not have any recesses in which dirt, toothpaste and/or saliva accumulate. The connector may also avoid any fragile structures by comprising substantially round edges, only, which may prevent easy breakage or damage of the surfaces.

[0069] To allow sufficiently good fitting of the brush head on the connector if production tolerances occur, the inner wall of the hollow portion of the head may be formed with at least one ribs, or two ribs being opposite each other, for precisely adjusting the head on the connector/handle. Furthermore, the at least one ribs may prevent compression of air in the hollow portion of the head which could act like a spring or as additional resistance while snapping the head on the connector/handle.

[0070] At least a portion of the head, e. g. the neck/shaft and the bristle carrier may be at least partially made from a material having a density from about 0.5 g/cm³ to about 1.2 g/cm³, or from about 0.7 g/cm³ to about 1.0 g/cm³, or about 0.9 g/cm³. For example, the head may be injection molded from a thermoplastic polymer, e.g. polypropylene having a

density of about 0.9 g/cm^3 . In contrast to the head, the handle may be at least partially made from a material having a significant higher density, i.e. a density from about 2.1 g/cm^3 to about 3.1 g/cm^3 , or from about 2.3 g/cm^3 to about 2.8 g/cm^3 , or from about 2.5 g/cm^3 to about 2.7 g/cm^3 .

[0071] The weight of the handle material may be relatively high, to provide a user with high-quality perception and comfortable feeling during use of the oral care implement. Usually users are accustomed that products, in particular in the personal health care sector, have a specific weight that guarantees high product quality and provides comfortable feeling during use of the product. Consequently, such oral care implement provides such superior product quality perception.

[0072] Further, since the material of the handle may have a higher density than the material of the head, the center of mass/center of gravity lies within the handle (even if the brush head is loaded with toothpaste) which enables users to perform a well-coordinated brushing technique with improved sensory feeling during brushing. The center of gravity provided in the center of the handle may provide an oral care implement which is better balanced and does not tip over/does not get head loaded once toothpaste is applied onto the brush head. When users apply different grip styles/brushing techniques, the oral care implement according to the present disclosure has the advantage that the center of gravity is in or very close to the pivot point of the wrist joint. A balanced toothbrush is easier to control in the mouth, thereby allowing more precise and accurate brushing movements which enables better cleaning.

[0073] While the high quality and relatively expensive handle of the oral care implement may be adapted for use over a longer period of time as compared to common manual toothbrushes which are discarded after about three months of use, the relatively cheap brush refill can be exchanged on a regular basis, e.g. after about three months. This provides a cost-efficient and environmentally sustainable high quality oral care implement with improved handling properties.

[0074] In the past, it has been seen that after use of the brush/after brushing the teeth the user usually stores the wet brush in a toothbrush beaker for drying. However, in a classical toothbrush beaker, drained fluids get collected and accumulated at the bottom of the beaker, and, the fluids stay in contact with the toothbrush for a longer period of time. Since the beaker is open on one side only, the toothbrush dries relatively slowly. Bacteria living in wet conditions/in a wet environment can grow quickly, contaminate the toothbrush and finally render the brush unhygienic. Consequently, there exists a need for a solution for hygienically storing and drying a manual toothbrush, thereby enabling remaining water, toothpaste slurry and saliva to drain off from the brush. The brush shall dry quickly thereby inhibiting bacterial growth.

[0075] The material of the head may be made of a non-magnetic or non-ferromagnetic material, while the material of the handle may be made from a magnetic and/or ferromagnetic material. Magnetic/ferromagnetic material possesses not only a relatively high density, and, thus, a relatively heavy weight, which may provide the oral care implement with the above-mentioned benefits, but the magnetic/ferromagnetic material also enables the oral care implement to be magnetically attachable to a magnetic holder. The magnetic/ferromagnetic material of the handle may allow for hygienic storage of the oral care implement.

If the oral care implement is magnetically attached to a magnetic holder, remaining water, toothpaste slurry and saliva can drain off from the brush. The oral care implement can dry relatively quickly. Consequently, bacteria growth can significantly be reduced, thereby rendering the oral care implement more hygienic. In contrast to a common toothbrush being stored in a toothbrush beaker where drained fluids get collected and accumulated at the bottom of the beaker, the brush according to the present disclosure is exposed to wet conditions over a significantly shorter period of time.

[0076] For example, the magnetic holder may have the form of a flat disk attachable to a wall. Such flat disk may represent an easy to clean surface. Further, a user just needs to bring the oral care implement in close proximity to the magnetic holder, and then the oral care implement gets attached automatically. No precise positioning or threading as in common toothbrush holder is required. Since the magnetic properties are merely provided in the handle, and not in the head, the head portion cannot accidentally be attached to the magnetic holder, thereby reducing the risk that the magnetic holder gets soiled.

[0077] The magnetic and/or ferromagnetic material forming at least a part of the handle may comprise an amorphous thermoplastic resin. The magnetic and/or ferromagnetic material may further comprise aluminum oxide, boron nitride or aluminum silicate. Furthermore, the magnetic and/or ferromagnetic material may comprise in addition or alternatively iron oxide. The magnetic and/or ferromagnetic material may further comprise glass fibers which may be pre-mixed with at least a portion of the amorphous thermoplastic resin. Such handle material allows for control of the weight of the handle in whatever location, e.g. by filler variation. Control of the overall toothbrush is required due to the relatively high weight of the handle. It is now possible to use the mass/weight distribution of the material for adaption of the inertial moment of the finished toothbrush.

[0078] The magnetic and/or ferromagnetic material may comprise from about 13 weight percent to about 30 weight percent of an amorphous thermoplastic resin; from about 3 weight percent to about 25 weight percent of aluminum oxide, boron nitride or aluminum silicate; and from about 45 weight percent to about 67 weight percent of iron oxide. Such composition provides a material density that is about three times the density of a standard plastic material used for toothbrushes, e.g. polypropylene. With higher weight and higher thermal conductivity, the material drives value perception, in particular in combination with a galvanic coating. Such coating may be made from real metal. The galvanic coating can be applied in a selective electroplating process. During this coating process for a multicomponent plastic part, a metallic layer is only deposited on a hard material while a further over molded soft component may remain unaffected.

[0079] The magnetic and/or ferromagnetic material may comprise about 27.5 weight percent of an amorphous thermoplastic resin, about 17 weight percent of aluminum oxide, about 51 weight percent of iron oxide, and about 4.5% glass fiber.

[0080] The amorphous thermoplastic resin may comprise a styrene resin, e.g. styrene acrylonitrile "SAN". The amorphous thermoplastic resin may be selected from the list consisting of acrylonitrile butadiene styrene, polystyrene, and styrene acrylonitrile.

[0081] The amorphous thermoplastic resin may comprise about 17% weight percent styrene acrylonitrile, and 10.5 weight percent of a mixture comprising polybutylene terephthalate and polyethylene terephthalate.

[0082] Surprisingly, it has been found out that said composition provides a high gravity molding material appropriate for injection molding or extrusion molding. A high specific gravity molding material high in surface hardness, excellent in coating characteristics as well as excellent in thermal conductivity is provided.

[0083] The use of molding materials having a relatively high specific gravity is known. Such molding materials usually contain a polymeric resin and a high-density filler such as iron oxide. However, in such molding materials the amount of iron oxide which can be included is limited as the thermal conductivity properties of the molding material are relatively poor. Thus, on the one side, lower thermal conductivity leads to relatively longer cycle times during manufacturing to allow the molding material to cool after molding. On the other side, if heavy polymeric materials are filled with high heat conductive additives such as metal powder or fibers, the addition of these materials leads to tight process windows in molding because of the immediate freezing when the molten material contacts the cold wall of the tool. This fast freezing leads to high injection speed and low flow length to wall thickness ratio at the produced part.

[0084] Now, it has been surprisingly found out that the molding material according to the present disclosure has a high specific gravity and optimally controlled thermal conductivity properties to reduce or expand the time needed for the molding material to cool during or after injection molding. Surprisingly, it has been found out that a relatively high percentage of iron oxide can be maintained in the molding material while improving on the thermal conductivity properties of the molding material. The addition of aluminum oxide, boron nitride or aluminum silicate provides the molding material with improved thermal conductivity as compared to materials containing a styrene resin and iron oxide only. This improved thermal conductivity may lead to lower cycle times as the molding material needs less time to cool after molding.

[0085] Another benefit of adding aluminum oxide, boron nitride or aluminum silicate to the material is the ability to increase the overall amount of iron oxide in the molding material as compared with materials comprising iron oxide and resins of the past. The improvements in the molding material properties come from the addition of relatively small amounts of aluminum oxide, boron nitride or aluminum silicate. A material composition comprising a relatively high percentage of iron oxide (magnetite), i.e. from about 45 weight percent to about 67 weight percent, preferably about 51 weight percent, provides good magnetic properties and a relatively heavy weight of the overall material.

[0086] Styrene acrylonitrile "SAN" provides high thermal resistance properties. The acrylonitrile units in the chain enable SAN to have a glass transition temperature greater than 100° C. The properties of SAN may allow for reduced cycle time due to relatively earlier and quicker transition temperature. Amorphous polymers are suitable for heavy resin compounds of the present disclosure due to the glass transition temperature T_g at which an amorphous polymer is transformed, in a reversible way, from a viscous or rubbery condition to a hard one. By injection molding of the heavy resin material of the present disclosure the temperature of the material melt is above the T_g region (viscous or rubbery condition). During cooling the compound attains the high T_g temperature early and reaches dimensional stability (glassy condition). Over-molding of the heavy resin material is possible as the material stays dimensional stable due to the high T_g of the material.

[0087] Polybutylene terephthalate (PBT) and/or polyethylene terephthalate (PET) provide the handle with high quality surface properties, including improved optical characteristics, and high impact strength. Once heated, a mixture of PBT and PET represent a high temperature-resistant melt having low viscosity and a high Melt Flow Index (MFI). Therefore, processability of the magnetic/ferromagnetic material during molding is improved.

[0088] It is known, that heavy resin materials tend to show high shrinkage effects for products having thick walls/dimensions. However, it has been surprisingly found out that glass fibers added to the magnetic/ferromagnetic material provide the material composition with improved stability and low shrinkage effects.

[0089] The material according to the present disclosure is an alternative to metal/zinc-die-cast material. The material of the disclosure enables to offer an attractive solution with respect to the manufacturing process according to the present disclosure, price and environment. This alternative allows the handle to have the look and feel in the final state like a metal product. At the same time the material of the present disclosure should be easily processable by injection molding and should save on the assembly effort. For example, for the process of the present disclosure there are three basic steps required: (1) injection molding of the handle **12**; (2) two-component injection molding of hard material and/or soft material, e.g. to form a thumb rest; and (3) electroplating of the handle, e.g. to form a metal layer in the form of a ring **18**. In contrast, when using a zinc-die-cast material five steps are needed: (1) manufacturing of the zinc-die-casted main part; (2) deflashing of the main part; (3) electroplating the main part; (4) separately producing a soft material part; (5) and assembling the main part with the separately produced soft material part. A lubricant may be added to the material to improve the molding processing fluidity.

[0090] Table 1 shows the flowability and heat transfer results of several different formulas/material compositions:

TABLE 1

Flowability and heat transfer				
Test-No.	20% SAN 80% Iron oxide	20% SAN 5% Aluminum oxide 75% Iron oxide	15% SAN 10% Aluminum oxide 75% Iron oxide	17% SAN 16% Aluminum oxide 67% Iron oxide
Specific weight [g/cm ³]	2.91	2.95	2.99	3.06

TABLE 1-continued

Flowability and heat transfer				
Test-No.	20% SAN 80% Iron oxide	20% SAN 5% Aluminum oxide 75% Iron oxide	15% SAN 10% Aluminum oxide 75% Iron oxide	17% SAN 16% Aluminum oxide 67% Iron oxide
1	21	16	13	9
2	20	16	13	9
3	20	16	13	10
4	21	16	13	9
5	20	16	14	9
6	20	16	13	8
7	20	16	13	9
8	20	16	13	9
9	20	16	13	9
10	20	16	13	9
Average (cm)	20.2	16	13.1	9
Content Al—Ox [%]	0	5	10	16
Heat transfer rate [W/m * K]	0.87	0.96	1.2	1.43
	0.89	1.06	1.22	1.41
	0.88	1.01	1.23	1.44
Average Value [W/m * K]	0.88	1.01	1.21666667	1.42666667

[0091] Graph 1, shown in FIG. 4, plots the average results of heat transfer and flow distance of the formulas from Table 1.

[0092] As can be seen, different fillers and different concentrations of fillers control the thermal conductivity or heat transmission and flowability of the material.

[0093] Test results revealed that the use of boron nitride or aluminum silicate showed very similar results to that of aluminum oxide depicted in Table 1 and Graph 1 above.

[0094] The heat energy and shear heating affect the fluidity of the heavy resin material, and thereby the process window for an effective injection molding process can be exactly controlled. Further, with the ability of the material of the present disclosure to fill any available cavities within the mold, it is possible to use the mass/weight distribution of the material for adaption of the inertial moment of the finished handle.

[0095] There are several advantages related to the material of the present disclosure: The handle manufactured with the material of the present disclosure looks and feels like a heavy metal handle and it is resistant to corrosion. The material also has manufacturing advantages and cost saving advantages with fast cycle times due to its heat transfer properties as compared to metal inserted or die-casted handles and products with assembled component parts. The material of the present disclosure requires less energy and other essential resources for manufacturing in comparison to zinc-die casted products.

[0096] In contrast to material compositions that are highly loaded with fillers, the magnetic/ferromagnetic material of the present disclosure shows optimized mechanical properties, in particular dimensional stability under heat and impact strength due to the improved melt viscosity and glass transition temperature.

[0097] The material of the present disclosure possesses the ability to adhere to other components/materials, e.g., substrates and resins, which is important for multicomponent injection molding, e.g. for molding handles comprising two or three different materials.

[0098] The tooth cleaning elements of the oral care implement, e.g. bundle of filaments forming one or a plurality of

tufts, may be attached to the head by means of a hot tufting process. One method of manufacturing the head with tufts of filaments embedded in the head may comprise the following steps: In a first step, tufts are formed by providing a desired amount of filaments. In a second step, the tufts are placed into a mold cavity so that ends of the filaments which are supposed to be attached to the head extend into said cavity. The opposite ends of the filaments not extending into said cavity may be either end-rounded or non-end-rounded. For example, the filaments may be not end-rounded in case the filaments are tapered filaments having a pointed tip. In a third step the head is formed around the ends of the filaments extending into the mold cavity by an injection molding process, thereby anchoring the tufts in the head. Alternatively, the tufts may be anchored by forming a first part of the head—a so called “sealplate”—around the ends of the filaments extending into the mold cavity by an injection molding process before the remaining part of the oral care implement is formed. Before starting the injection molding process the ends of the tufts extending into the mold cavity may be optionally melted or fusion-bonded to join the filaments together in a fused mass or ball so that the fused masses or balls are located within the cavity. The tufts may be held in the mold cavity by a mold bar having blind holes that correspond to the desired position of the tufts on the finished head of the oral care implement. In other words, the tufts attached to the head by means of a hot tufting process are not doubled over a middle portion along their length and are not mounted in the head by using an anchor/staple. The tufts are mounted on the head by means of an anchor-free tufting process.

[0099] Alternatively, the head for the oral care implement may be provided with a bristle carrier having at least one tuft hole, e.g. a blind-end bore. A tuft comprising a plurality of filaments may be fixed/anchored in said tuft hole by a stapling process/anchor tufting method. This means, that the filaments of the tuft are bent/folded around an anchor, e.g. an anchor wire or anchor plate, for example made of metal, in a substantially U-shaped manner. The filaments together with the anchor are pushed into the tuft hole so that the anchor penetrates into opposing side walls of the tuft hole

thereby anchoring/fixing/fastening the filaments to the bristle carrier. The anchor may be fixed in opposing side walls by positive and frictional engagement. In case the tuft hole is a blind-end bore, the anchor holds the filaments against a bottom of the bore. In other words, the anchor may lie over the U-shaped bend in a substantially perpendicular manner. Since the filaments of the tuft are bent around the anchor in a substantially U-shaped configuration, a first limb and a second limb of each filament extend from the bristle carrier in a filament direction. Filament types which can be used/are suitable for usage in a stapling process are also called “two-sided filaments”. Heads for oral care implements which are manufactured by a stapling process can be provided in a relatively low-cost and time-efficient manner.

[0100] The following is a non-limiting discussion of example embodiments of oral care implements and parts thereof in accordance with the present disclosure, where reference to the Figures is made.

[0101] FIG. 1 shows a manual oral care implement 10, in this specific embodiment a manual toothbrush 10. The manual toothbrush 10 comprises a handle 12 to which a connector 14 is attached, and a brush head 16. The brush head 16 is repeatedly attachable to and detachable from the handle 12 via connector 14.

[0102] FIGS. 2 to 5 show a schematic perspective view, a side view, a front view and a top-down view of handle 12, respectively, handle 12 comprising connector 14. The connector 14 comprises a first substantially cylindrical section 18, a second substantially cylindrical section 20, and an at least partially conically shaped section 22 connecting the first and the second cylindrical sections 18, 20. The first substantially cylindrical section 18, the at least partially conically shaped section 22 and the second substantially cylindrical sections 20 are arranged in consecutive order and define together a longitudinal length extension 24 of connector 14. The first substantially cylindrical section 18 and the second substantially cylindrical section 20 are placed off-center with respect to the longitudinal length extension 24 of the connector 14. As derivable from side view of FIG. 7, the first and the second substantially cylindrical sections 18, 20 have a first and a second longitudinal central axis 74, 76, respectively, which are defined as the symmetry axis of the first and the second substantially cylindrical sections 18, 20. The first and the second substantially cylindrical sections 18, 20 may be placed/arranged with respect to each other so that the second longitudinal central axis 76 of the second cylindrical section 20 is located off-center with respect to the first longitudinal central axis 74 of the first cylindrical section 18 by a distance 78 of about 1 mm to about 2.5 mm, or of about 1.5 mm to about 2 mm, or of about 1.65 mm. In other words, when seen in a side view (cf. FIGS. 3, 7 and 8), the central axis 76 of the second substantially cylindrical section 20 is offset/eccentric from the longitudinal central axis 74 of the first substantially cylindrical section 18 by a distance 78 of about 1 mm to about 2.5 mm, or of about 1.5 mm to about 2 mm, or of about 1.65 mm.

[0103] The handle 12 has a distal end 54 and a proximal end 56, the proximal end 56 being closest to a brush head 16 attachable to the handle 12. As shown in FIGS. 8 to 10, proximal end 56 of handle 12 comprising a hollow portion/recess 58 into which a portion of the first substantially cylindrical section 18 is fixed, e.g. by a press-fitting process and/or gluing.

[0104] The proximal end 56 of the handle 12 comprises a chamfered surface 60. The cross-sectional area 62 extending substantially perpendicular to the longitudinal length extension 64 and the chamfered surface 60 define an angle α from about 15° to about 30°, or from about 18° to about 28°, or about 25°.

[0105] FIGS. 6 and 7 show a schematic front and side view of connector 14, respectively. The first substantially cylindrical section 18 and the second substantially cylindrical section 20 have each a length extension 26, 28 and a cross-sectional area 30, 32 extending substantially perpendicular to the length extension 26, 28. The cross-sectional area 30 of the first substantially cylindrical section 18 and the second cross-sectional area 32 of the second substantially cylindrical section 20 is substantially circular. The first substantially cylindrical section 18 has a cross-sectional area 30 being greater than the cross-sectional area 32 of the second substantially cylindrical section 20. The first cross-sectional area 30 has a diameter 36 of about 8 mm to about 10 mm, or about 9 mm, while the second cross-sectional area 32 has a diameter 34 of about 4 mm to about 6 mm, or about 5 mm.

[0106] The first substantially cylindrical section 18 comprises a flattening portion 38 at the outer lateral surface 80 of connector 14. Flattening portion 38 extends along the length extension 26 of the first substantially cylindrical section 18. As further derivable from FIGS. 8 to 10, the flattening portion comprises a recess 40 which forms an inner cavity 82 within the connector 14. A spring-loaded ball element 42 is inserted into cavity 82 and is fixed therein, e.g. by a press-fitting process and/or gluing. The spring-loaded ball element 42 is an element with a snap-fit locking mechanism to provide sufficiently strong connection and stability between head 16 and handle 12 in an axial direction, i.e. along the longitudinal length extension 24 of the connector and oral care implement 10. The spring-loaded ball element 42 comprises a ball 44 and a spring 46, the spring 46 applying a radial force onto the ball 44 towards the outer circumference 48 and outer lateral surface 80 of connector 14. When the brush head 16 is attached to the handle, ball 44 extends slightly beyond the outer lateral surface of the first substantially cylindrical section 18 and arrests in a corresponding recess 70 provided in a hollow portion (66) of the head shaft (cf. FIGS. 11 and 12). Both, the spring 46 and the ball 44 may be made from stainless steel.

[0107] The first and the second substantially cylindrical sections 18, 20 have a first and a second outer lateral surface 50, 52, respectively, and the first and the second substantially cylindrical sections 18, 20 are arranged with respect to each other so that a part of the first outer lateral surface 50 and a part of the second outer lateral surface 52 are substantially in straight alignment. The flattening portion 38 is arranged opposite the first and second outer surfaces 50, 52 being substantially in straight alignment.

[0108] FIG. 11 shows a perspective view of brush head 16, and FIG. 12 a respective bottom view. Head 16 comprises hollow portion 66 for receiving the second substantially cylindrical section 20, the at least partially conically shaped section 22 and a part of the first substantially cylindrical section 18 of connector 14. Hollow portion 66 has an inner wall 68 comprising recess 70 for receiving a portion of ball 44 of the spring-loaded ball element 42. Inner wall 68 of

hollow portion 66 further comprises two ribs 72 being arranged opposite each other for precisely adjusting the head 16 on the connector 14.

[0109] FIG. 13 shows a flow chart of the steps for manufacturing the handle 12 comprising the connector 14 of the oral care implement 10 according to the present disclosure: In step 1000 handle 12 with distal end 54 and proximal end 56 comprising hollow portion 58 is injection molded. A soft component forming a thumb rest 102 is injection molded over the handle material. In step 2000 handle 12 is covered with a metal coating 104 by electroplating. In step 3000 at least a part of the connector 14 is injection molded, the connector 14 having an outer lateral surface 80 and a recess therein, and the recess forming a cavity 82 within the connector 14. The connector may be injection molded from PBT, optionally comprising about 30 weight % glass fibers. In step 4000 a spring-loaded ball-snap element 42 is inserted and fixed in the cavity 82 of the connector 14 by press-fitting. In step 5000 the connector 14 comprising the spring-loaded ball-snap element 42 is inserted into the hollow portion 58 at the proximal end 56 of the handle 12. The connector 14 is fixed in the hollow portion 58 by gluing, or alternatively by welding and/or press-fitting. In step 6000 a ring 100, which may be made from stainless steel is attached to the proximal end 56 of the handle 12 by press-fitting and gluing. Optionally, a logo or indication element 106 may be attached onto the surface at the distal end 54 of the handle 12, for example by applying a heat transfer foil, metal letters or a metal emblem.

[0110] In the context of this disclosure, the term “substantially” refers to an arrangement of elements or features that, while in theory would be expected to exhibit exact correspondence or behavior, may, in practice embody something slightly less than exact. As such, the term denotes the degree by which a quantitative value, measurement or other related representation may vary from a stated reference without resulting in a change in the basic function of the subject matter at issue.

[0111] The dimensions and values disclosed herein are not to be understood as being strictly limited to the exact numerical values recited. Instead, unless otherwise specified, each such dimension is intended to mean both the recited value and a functionally equivalent range surrounding that value. For example, a dimension disclosed as “40 mm” is intended to mean “about 40 mm.”

What is claimed is:

1. A method for manufacturing a handle, a connector, and a head, the head being repeatedly attachable to and detachable from the handle via the connector, the method comprising the steps of:

injection molding of at least a part of the handle having a distal end and a proximal end opposite the distal end, the proximal end comprising a hollow portion;

injection molding of at least a part of the connector having an outer lateral surface and a recess therein, the recess forming a cavity within the connector;

providing a spring-loaded ball-snap element comprising a ball and a spring configured to apply a radial force onto the ball;

inserting the spring-loaded ball-snap element into the cavity of the connector and fixing the spring-loaded ball-snap element therein so that the spring applies a force onto the ball in a direction towards the outer lateral surface of the connector;

injection molding of at least a part of the head;

inserting the connector into the hollow portion of the handle and fixing the connector therein by at least one of gluing, welding, and press-fitting, whereby a portion of the connector having the spring-loaded ball-snap element therein outwardly extends from the proximal end of the handle along the longitudinal axis, and wherein the ball slightly extends beyond the connector's outer lateral surface surrounding the ball.

2. The method of claim 2, wherein the method further comprises the step of electroplating at least a portion of the handle.

3. The method of claim 2, wherein the method further comprises the step of electroplating at least a portion of the handle.

4. The method of claim 1, wherein the handle is injection molded so that the proximal end of the handle has an upper surface that is at least partially chamfered, wherein an angle α from about 15° to about 30° is formed between the chamfered upper surface and a cross-sectional area extending substantially perpendicular to the longitudinal axis.

5. The method of claim 1, wherein the connector is injection molded so that at least a first substantially cylindrical section, a second substantially cylindrical section, and an at least partially conically shaped section connecting the first and second cylindrical sections are formed, wherein the first substantially cylindrical section, the at least partially conically shaped section, and the second substantially cylindrical section are arranged in consecutive order along the longitudinal axis and wherein the first substantially cylindrical section and the second substantially cylindrical section are placed off-center with respect to the longitudinal axis.

6. The method of claim 5, wherein the connector is formed so that at least one of the first and second substantially cylindrical sections comprises a flattening portion.

7. The method of claim 6, wherein the connector is formed so that the flattening portion is provided with the recess forming the cavity.

8. The method of claim 6, wherein the head is formed so that the head comprises a distal end and a proximal end opposite to the distal end, and the proximal end comprises a hollow portion (66) for receiving a portion of the connector when the head is attached to the handle, the hollow portion comprises an inner wall, and the inner wall comprises a recess for receiving the ball of the spring-loaded ball-snap element.

9. The method of claim 8, wherein the head is formed so that the inner wall of the hollow portion comprises two ribs arranged opposite to each other.

* * * * *