



US 20190294720A1

(19) **United States**

(12) **Patent Application Publication**

Beringer et al.

(10) **Pub. No.: US 2019/0294720 A1**

(43) **Pub. Date: Sep. 26, 2019**

(54) **USER INTERFACE AND PROCESS TO GENERATE JOURNEY INSTANCE BASED ON ONE OR MORE PIVOT IDENTIFIERS AND ONE OR MORE STEP IDENTIFIERS**

G06F 3/0482 (2006.01)

G06F 3/0484 (2006.01)

(52) **U.S. Cl.**

CPC *G06F 17/30554* (2013.01); *G06F 3/0483* (2013.01); *G06F 17/30598* (2013.01); *G06F 3/04842* (2013.01); *G06F 17/30867* (2013.01); *G06F 3/0482* (2013.01)

(71) Applicant: **Splunk Inc.**, San Francisco, CA (US)

(72) Inventors: **Joerg Beringer**, Redwood City, CA (US); **Isabelle Park**, San Mateo, CA (US); **Joshua Walters**, Santa Clara, CA (US); **Eric Tschetter**, Redwood City, CA (US); **Simon Fishel**, San Francisco, CA (US)

(57) **ABSTRACT**

Systems and methods are disclosed for generating one or more journey instances from events having raw machine data associated with a timestamp. The system generates a user interface that includes field identifiers associated with the plurality events for selection as one or more pivot identifiers and one or more step identifiers. Based on the one or more pivot identifiers, the system identifies related events that share a common field value, and based on the one or more step identifiers, the system groups the related events into a subset of events. Using the subset of events the system builds a journey instance.

(21) Appl. No.: **15/936,356**

(22) Filed: **Mar. 26, 2018**

Publication Classification

(51) **Int. Cl.**

G06F 17/30 (2006.01)

G06F 3/0483 (2006.01)

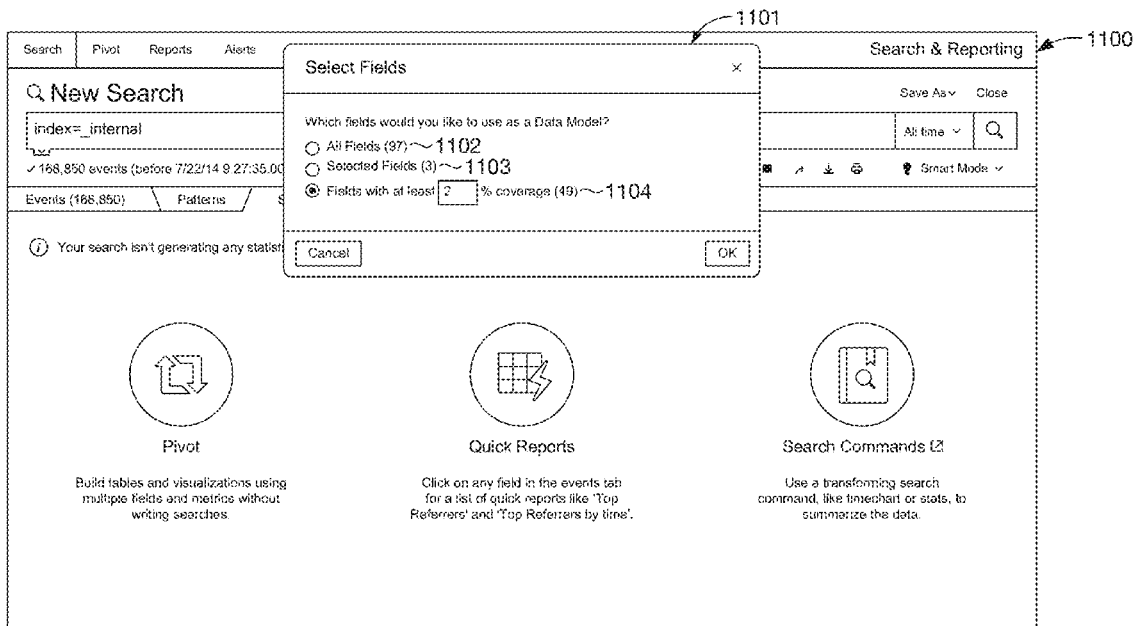

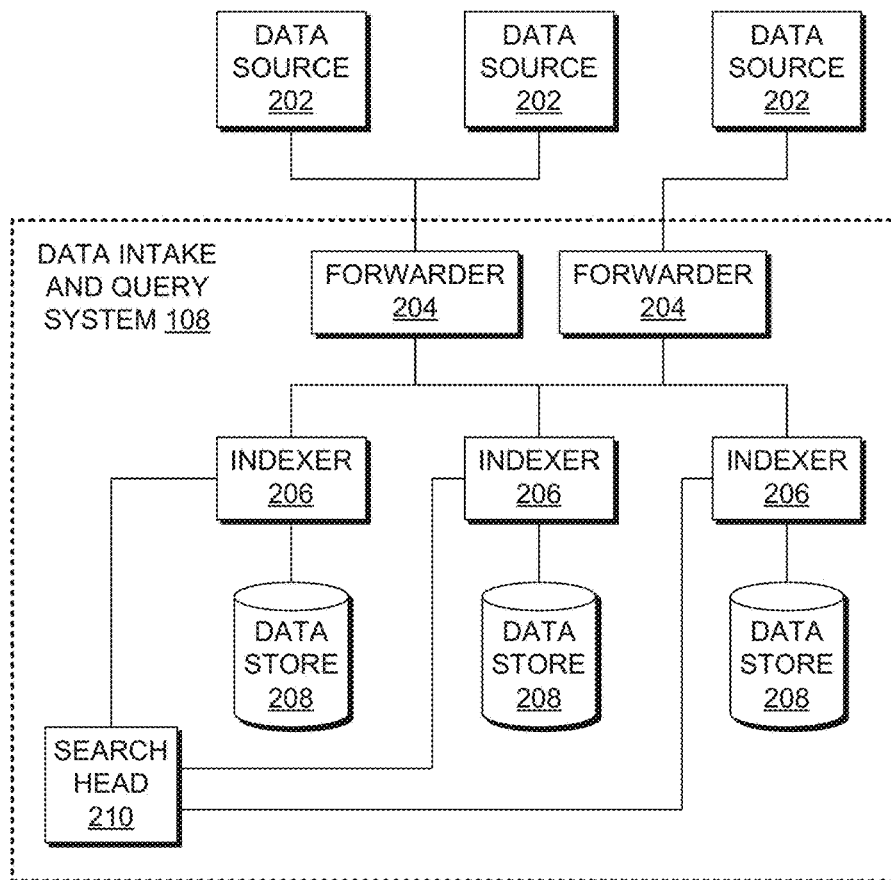
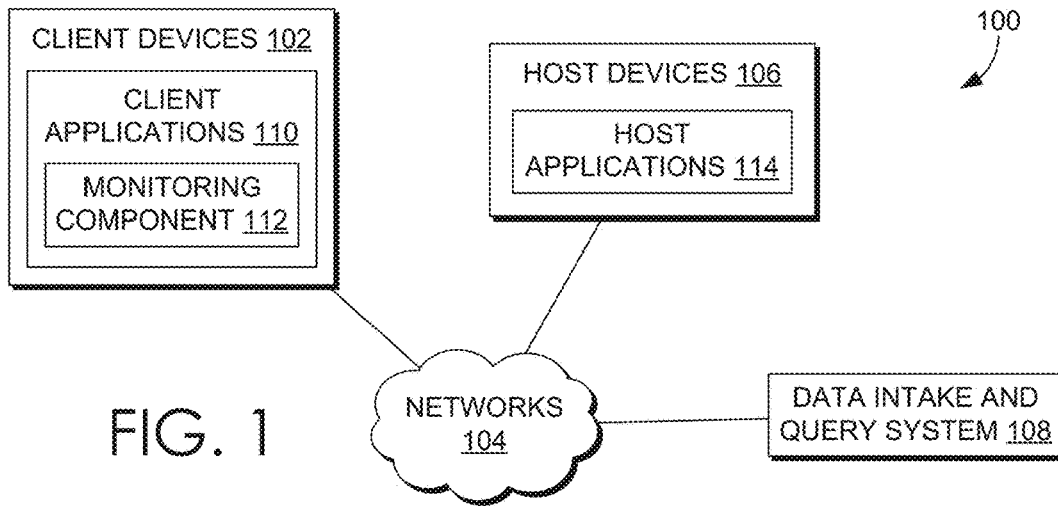

FIG. 2

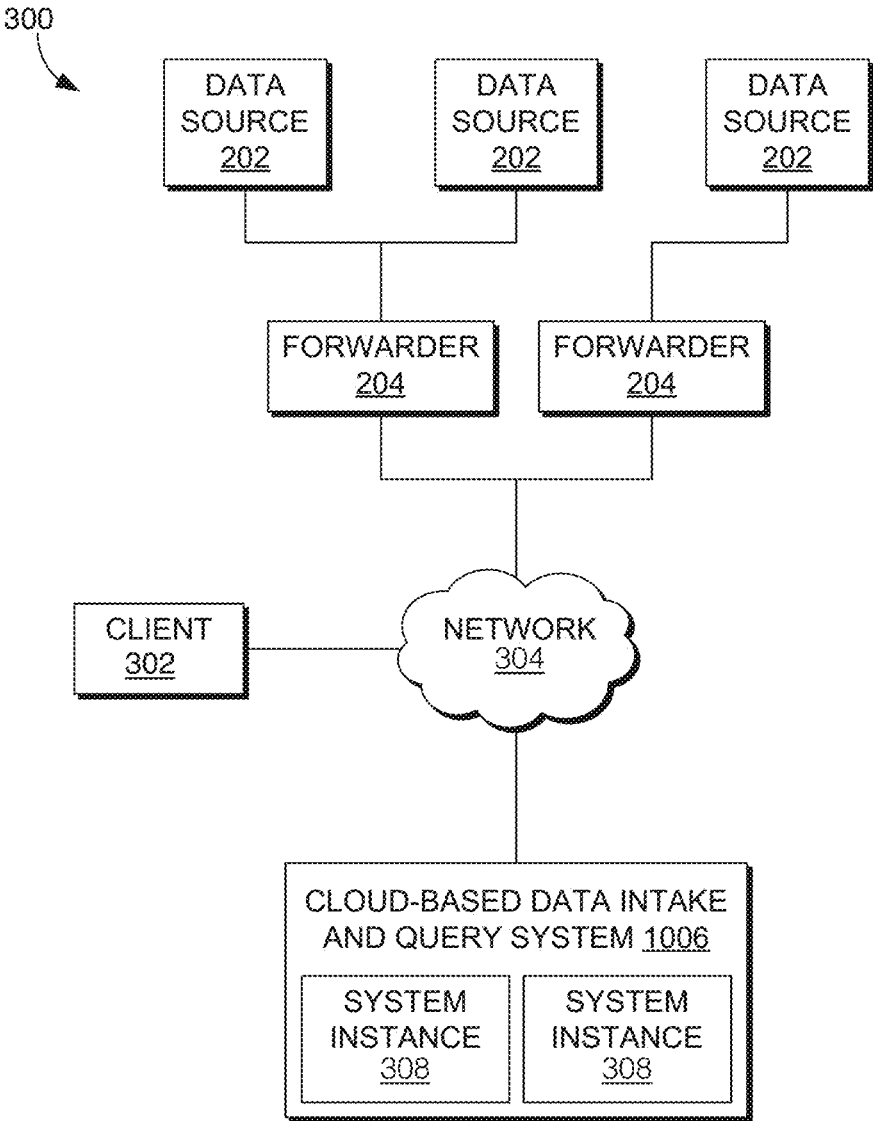

FIG. 3

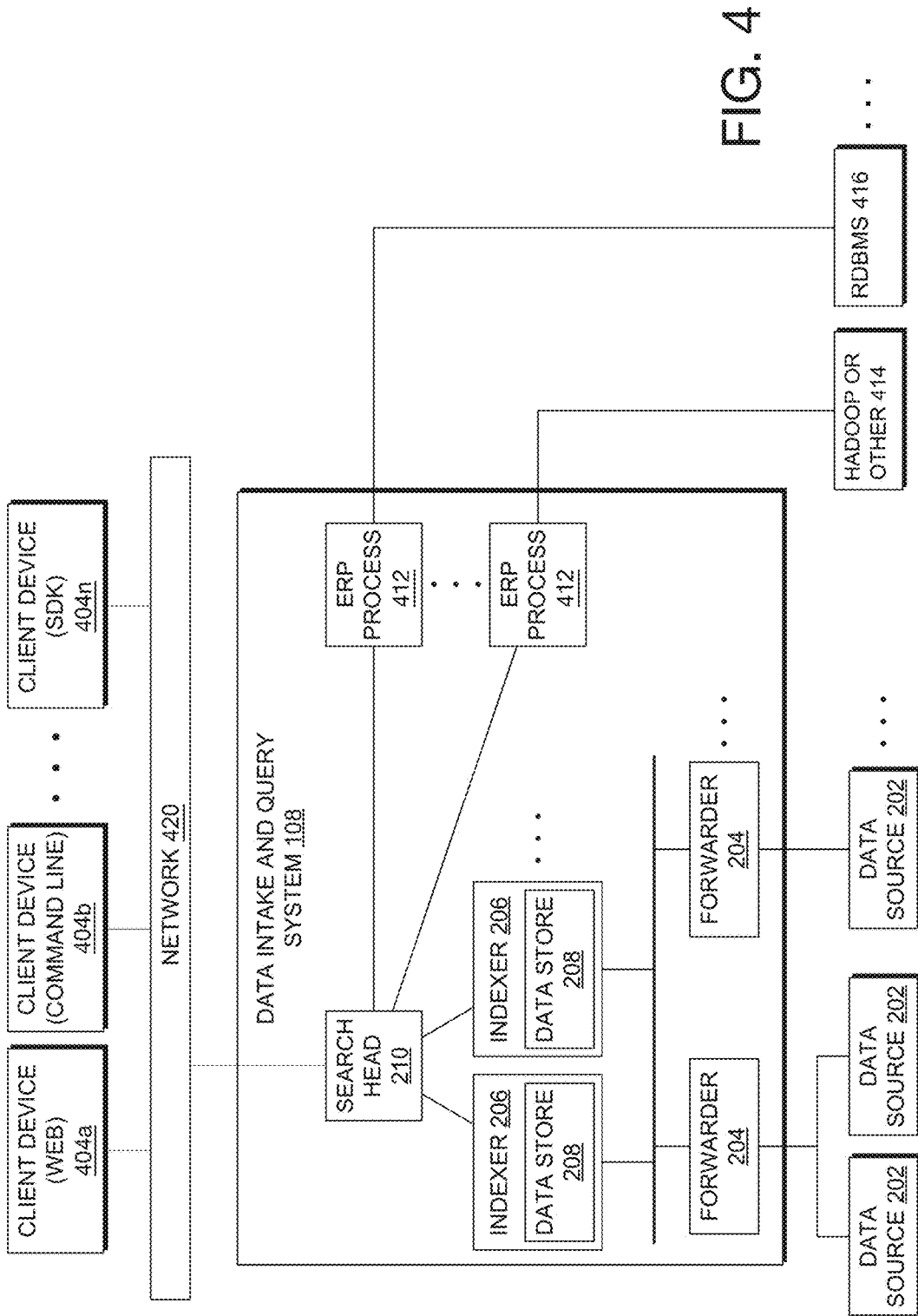

FIG. 4

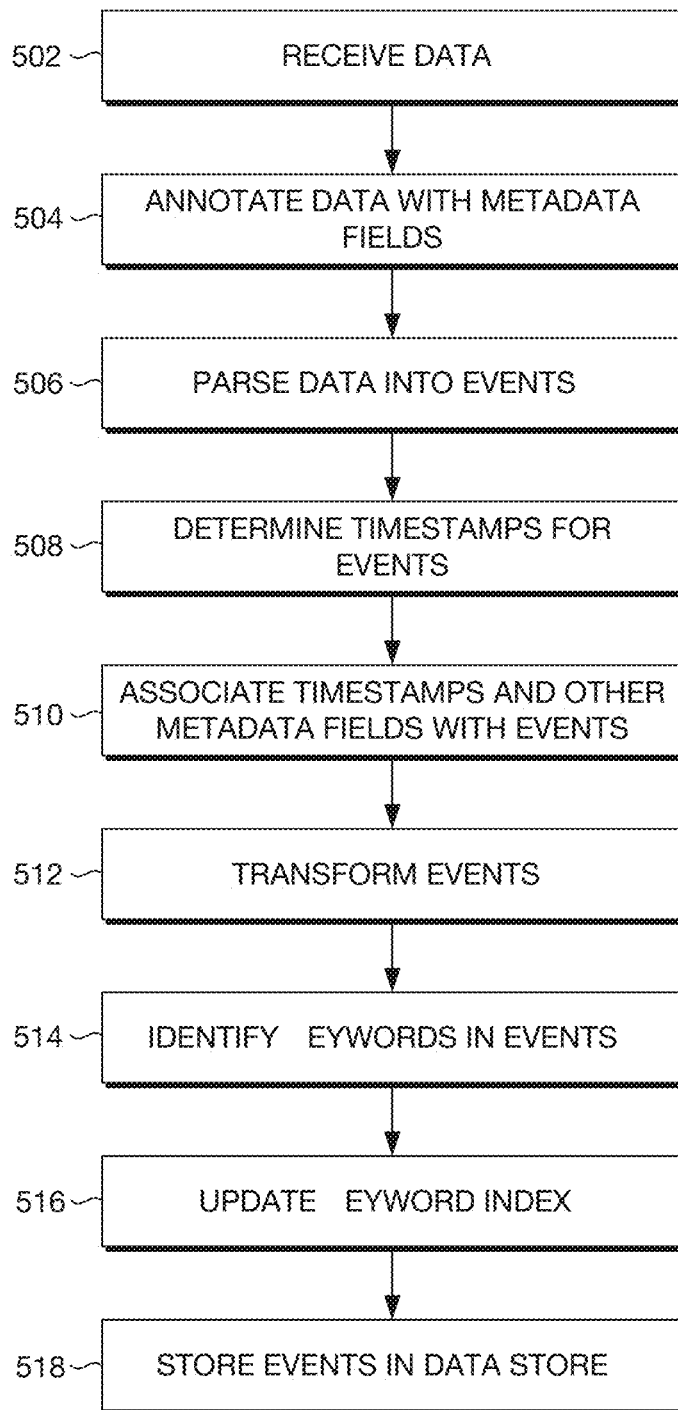

FIG. 5A

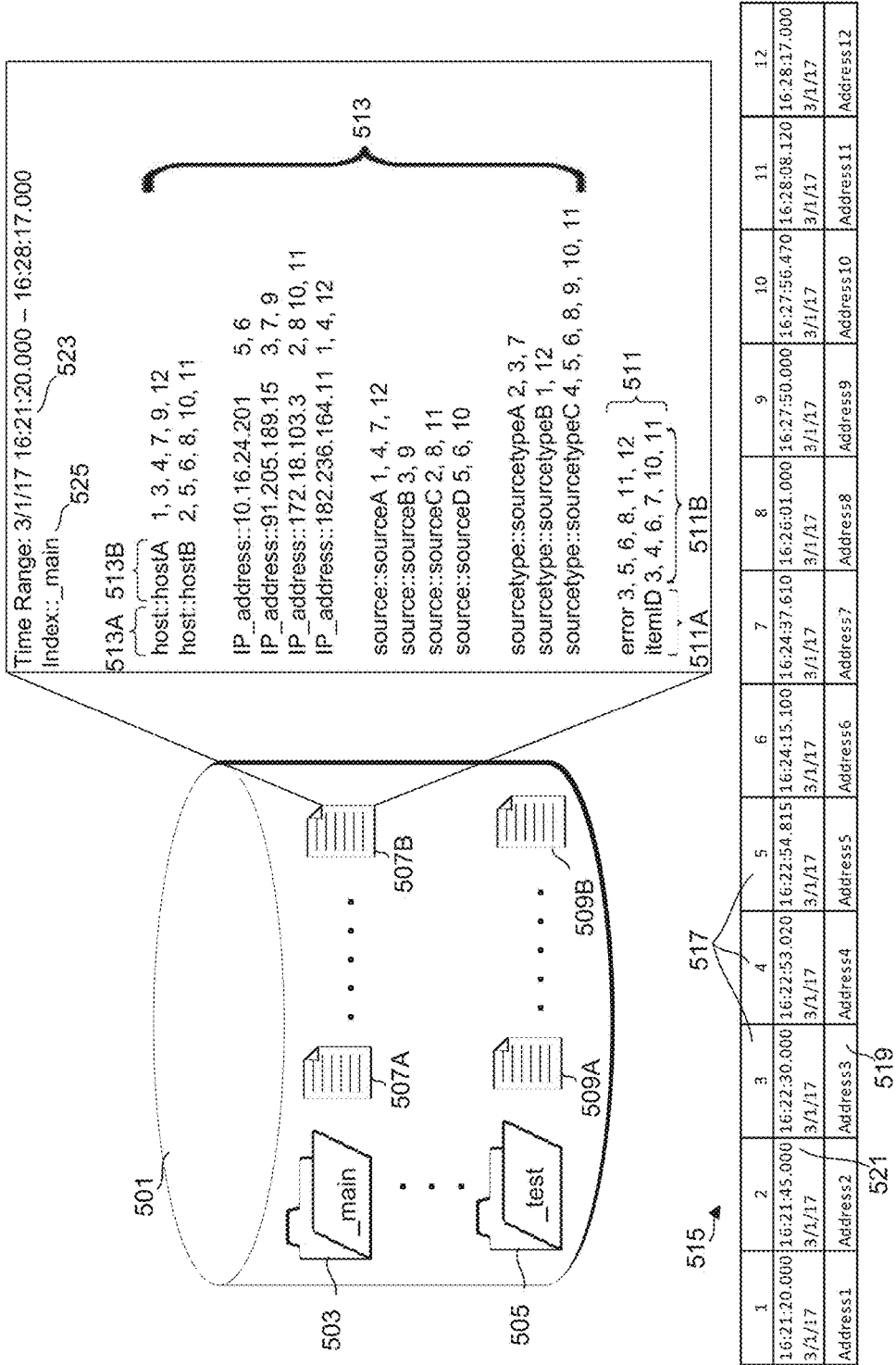

FIG. 5B

Time	535	Host	536	Source	537	Source Type	538	Event	539
531	10/10/2000 1:55 p.m.	www1	536	access.log	537	access_combined	538	127.0.0.1 - frank [10/Oct/2000:13:55:36 -0700] "GET /apache.gif HTTP/1.0" 200 2326 [0.0947]	539 540 541 542 543 544 545
532	10/10/2000 1:56 p.m.	www2	536	access.log	537	access_combined	538	127.0.0.1 - bob [10/Oct/2010:13:55:36 -0700] "GET /mickey_mouse.gif HTTP/1.0" 200 [298] 0.0899	539 540 541 542 543 544 545 546
533	10/10/2000 1:57 p.m.	www2	536	access.log	537	access_combined	538	127.0.0.1 - carlos [10/Oct/2010:13:57:36 -0700] "GET /donald_duck.gif HTTP/1.0" 200 2900 0.0857	539 540 541 542 543 544 545 546
534	10/10/2000 1:58 p.m.	www2	536	error.log	537	apache_error	538	[Sunday Oct 10 1:59:33 2010] [error] [client 127.10.1.1.015] File does not exist: /home/reba/public_html/images/daffy_duck.gif	539 540 541 542 543 544 545 546

FIG. 5C

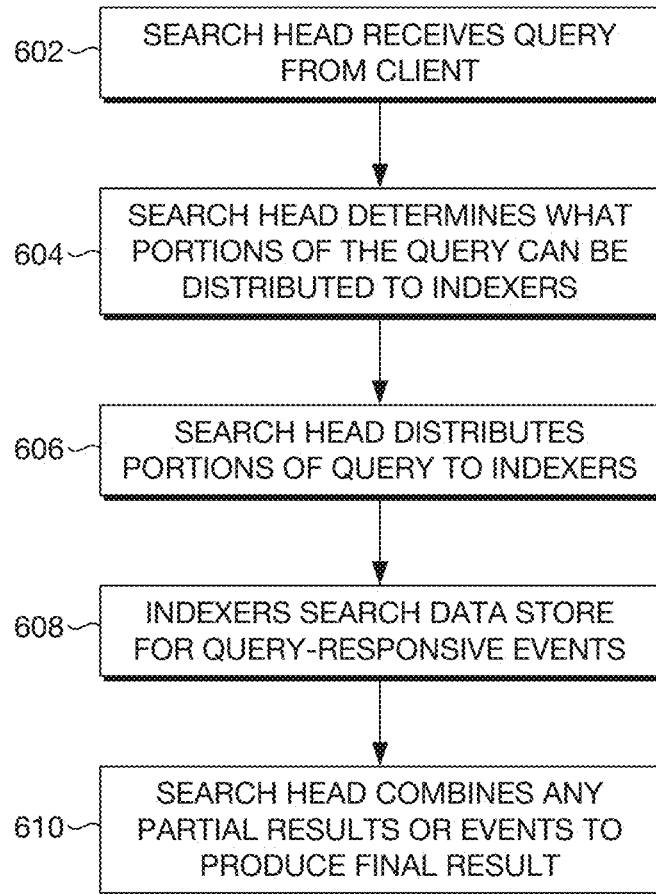

FIG. 6A

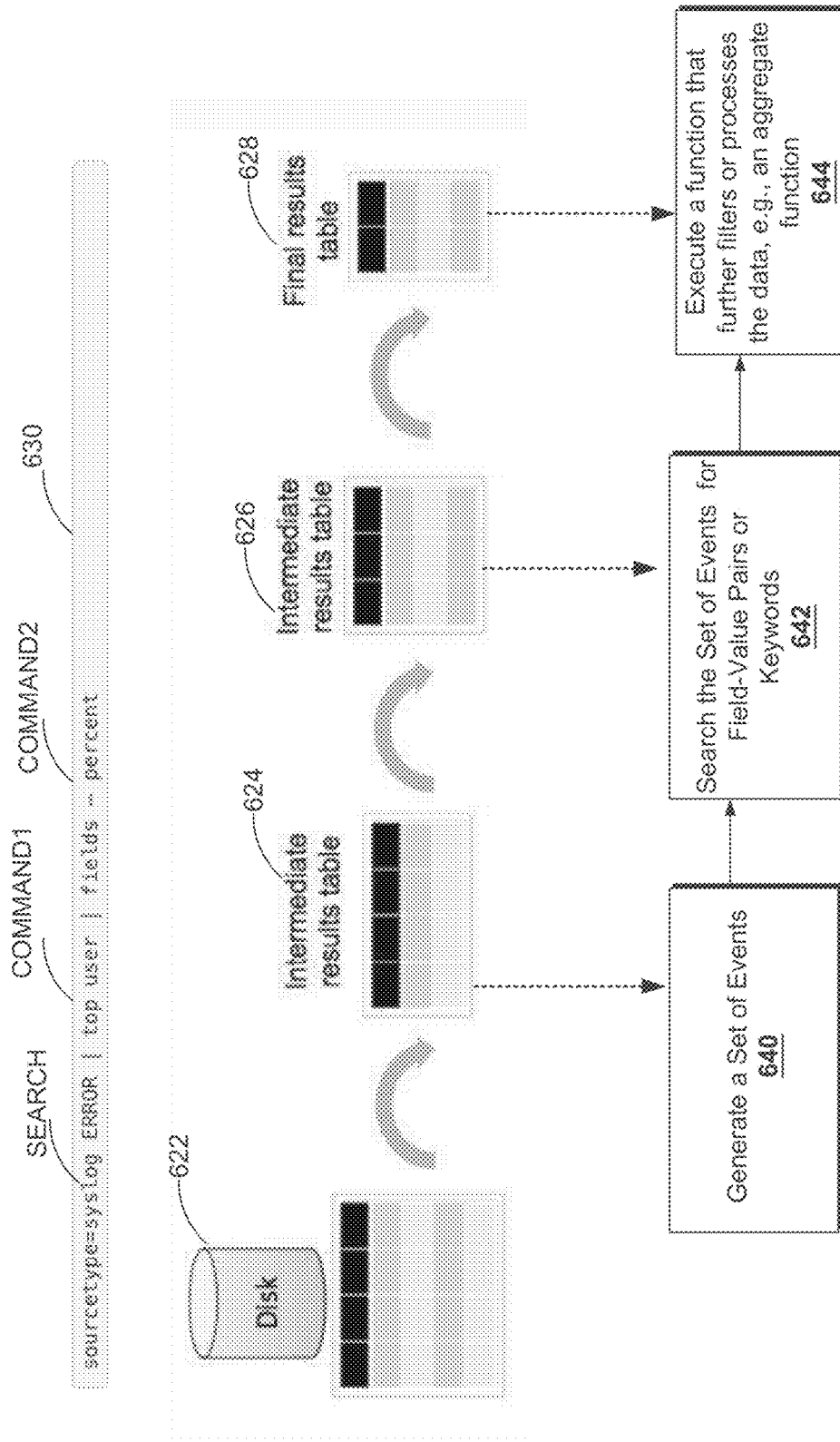

FIG. 6B

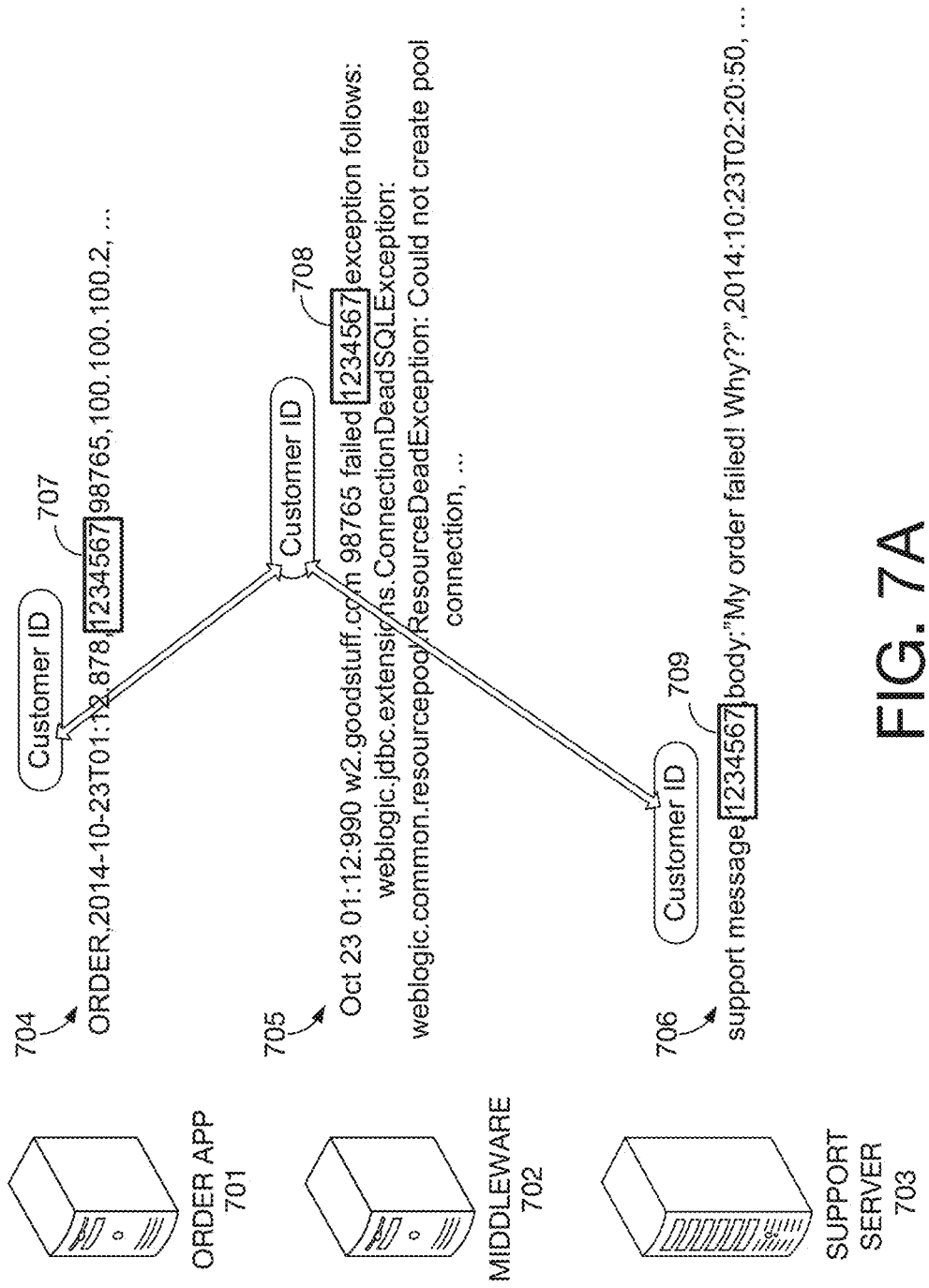

FIG. 7A

Time	Host	Source	Source Type	Event
10/10/2000 1:55 p.m.	www1	access.log	access_combined	127.0.0.1 - frank [10/Oct/2000:13:55:36 -0700] "GET /apache.gif HTTP/1.0" 200 2326 0.0947
10/10/2000 1:56 p.m.	www2	access.log	access_combined	127.0.0.1 - bob [10/Oct/2010:13:56:36 -0700] "GET /mickey_mouse.gif HTTP/1.0" 200 2980 0.0899
10/10/2000 1:57 p.m.	www2	access.log	access_combined	127.0.0.1 - carlos [10/Oct/2010:13:57:36 -0700] "GET /donald_duck.gif HTTP/1.0" 200 2900 0.0857
10/10/2000 1:58 p.m.	www2	error.log	apache_error	[Sunday Oct 10 1:59:33 2010] [error] [client 127.10.1.1.015] File does not exist: /home/reba/public_html/images/daffy_duck.gif

713

714

715

719

722

Keyword Search
Directly in Event Data

Search Time
Field Extraction

712

Search Bar

Search Time
Field Extraction

```
Clientip = <set of events> | <regex rule> 716
Status_code = <set of events> | <regex rule>
Response_time = <set of events> | <regex rule>
Size_of_returned_object = <set of events> |
<regex rule>
```

Configuration File

FIG. 7B

FIG. 7C

IP	Time	Host	Source	Status Type	Source
55000	10/10/2015 1:35 p.m.	www1	access.log	access_combined	127.0.0.1 - frank [10/Oct/2015:13:35:36 -0700] "GET /apache.gif HTTP/1.0" 200 2436 0.0847
55001	10/10/2015 1:56 p.m.	www2	access.log	access_combined	127.0.0.1 - bob [10/Oct/2015:13:56:34 -0700] "GET /nickel_mouse.gif HTTP/1.0" 200 2486 0.0899
55002	10/10/2015 1:57 p.m.	www2	access.log	access_combined	127.0.0.1 - carles [10/Oct/2015:13:57:36 -0700] "GET /donald_duck.gif HTTP/1.0" 200 2909 0.0857
55003	10/10/2015 1:59 p.m.	www2	error.log	apache_error	[Sun Oct 10 1:58:33 2015] [error] [client 127.0.0.1:5151] file does not exist: /home/tebb/public_html/images/doffy_duck.gif
55004	10/10/2015 1:59 p.m.	www2	access.log	access_combined	127.0.0.1 - ugg [10/Oct/2015:13:59:36 -0700] "GET /donald_duck.gif HTTP/1.0" 200 2900 0.0887
55005	10/10/2015 2:00 p.m.	www1	access.log	access_combined	127.0.0.1 - matt [10/Oct/2015:14:00:36 -0700] "GET /goofy.gif HTTP/1.0" 200 2320 0.0867
55006	10/10/2015 2:01 p.m.	www2	error.log	apache_error	[Sun Oct 10 2:01:18 2015] [error] [client 127.0.0.1:5151] file does not exist: /home/public_html/images/funny.gif
55007	10/10/2015 2:02 p.m.	www1	access.log	access_combined	127.0.0.1 - bob [10/Oct/2015:14:02:36 -0700] "GET /prospector.gif HTTP/1.0" 200 5060 0.0867

Event Reference	Field Name	Field Value
55000	client_ip	127.0.0.1
55002	client_ip	127.0.0.1
55005	client_ip	127.0.0.1
55007	client_ip	127.0.0.1

Event Reference	Field Name	Field Value
55000	client_ip	127.0.0.1
55002	client_ip	127.0.0.1
55005	client_ip	127.0.0.1
55007	client_ip	127.0.0.1

731

732

733

734

725

722

723

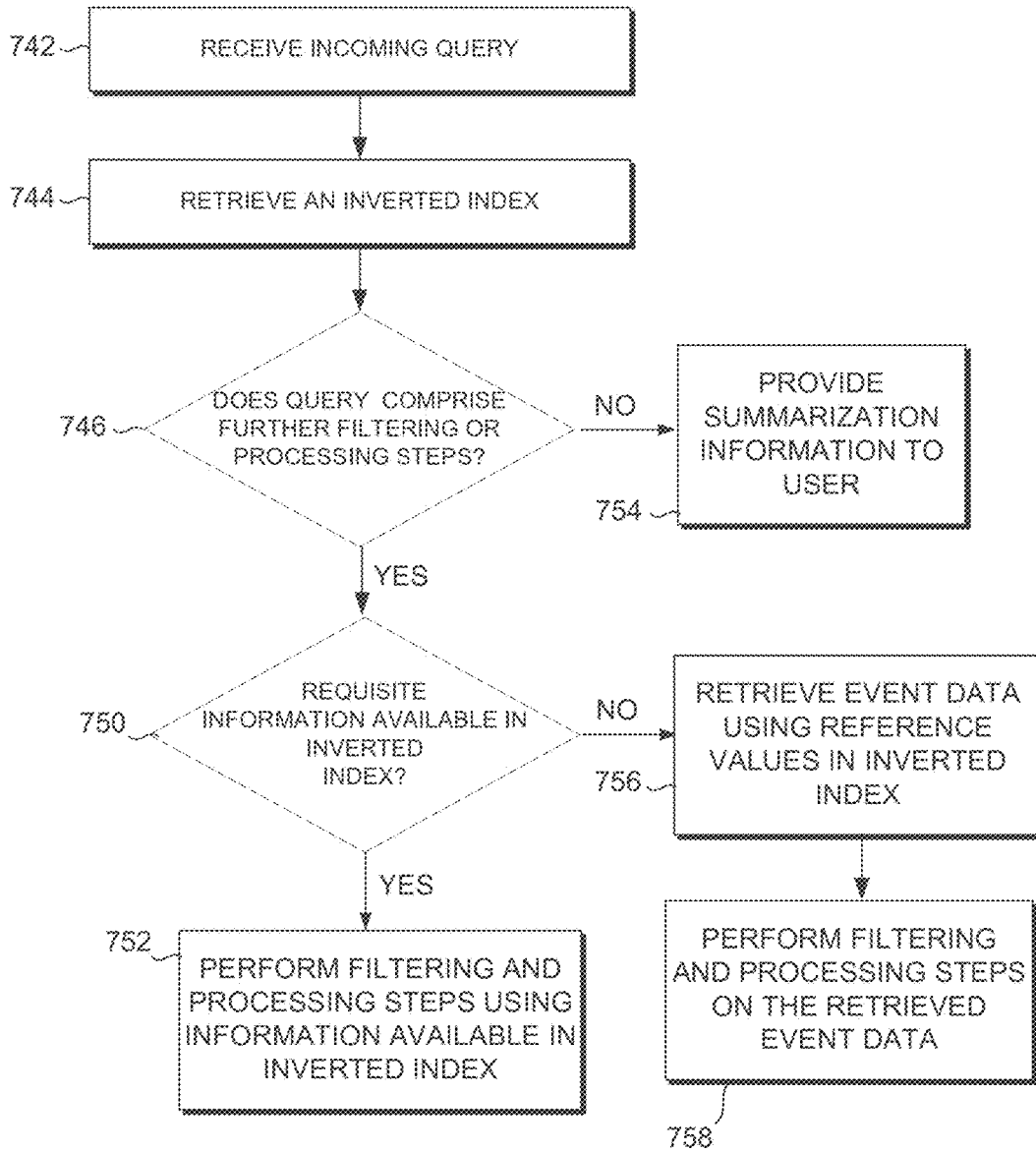

FIG. 7D

Search Screen 800

Search Pivot Reports Alerts Dashboards Search & Reporting

Q New Search Save as menu Close

buttercupgames Search Bar 802 Time Range Picker 812 All time v Q

✓ 36,819 events (before 4/30/14 2:19:02.000 PM) Search Results Tabs 804 Smart Mode v

Events (36,819) Visualization Search action buttons Search mode selector

Format Timeline v -- Zoom Out + Zoom to Selection x Deselect 1 hour per column

Timeline 805

824

Hide Fields	Format	20 Pair Page	Event	Events List 808
> All Fields	4/28/14	< Prev 1 2 3 4 5 6 7 8 9 ... Next >	91.205.189.15 -- [28/Apr/2014:18:22:16] "GET /oldlink?itemId=EST-14&SESSIONID=SD6SL7FF7AD5FF53113 HTTP 1.1" 200 1665 "http://www.buttercupgames.com/oldlink?itemId=EST-14" Mozilla/5.0 (Windows NT 6.1; WOW 64) AppleWebKit/536.5 (KHTML, like Gecko) Chrome/19.0.1084.46 Safari/536.5	91.205.189.15 -- [28/Apr/2014:18:22:16] "GET /oldlink?itemId=EST-14&SESSIONID=SD6SL7FF7AD5FF53113 HTTP 1.1" 200 1665 "http://www.buttercupgames.com/oldlink?itemId=EST-14" Mozilla/5.0 (Windows NT 6.1; WOW 64) AppleWebKit/536.5 (KHTML, like Gecko) Chrome/19.0.1084.46 Safari/536.5
Select Fields 820 a host 3 828 a source 3 a sourcetype 1	4/28/14 6:20:56.000 PM		182.236.164.11 -- [28/Apr/2014:18:20:56] "GET /cart.do?action=addtocart&itemId=EST-15&productid=85-AG-G09&SESSIONID=SD6SL8FF10ADFF53101 HTTP 1.1" 200 2252 "http://www.buttercupgames.com/oldlink?itemId=EST-15" Mozilla/5.0 (Macintosh; Intel Mac OS X 10_7_4) AppleWebKit/536.5 (KHTML, like Gecko) Chrome/19.0.1084.46 Safari/536.5	182.236.164.11 -- [28/Apr/2014:18:20:56] "GET /cart.do?action=addtocart&itemId=EST-15&productid=85-AG-G09&SESSIONID=SD6SL8FF10ADFF53101 HTTP 1.1" 200 2252 "http://www.buttercupgames.com/oldlink?itemId=EST-15" Mozilla/5.0 (Macintosh; Intel Mac OS X 10_7_4) AppleWebKit/536.5 (KHTML, like Gecko) Chrome/19.0.1084.46 Safari/536.5
Interesting Fields 822 a action 5 # bytes 100+ a category/d 8 a clientip 100+ # date_hour 24 # date_mday 8 # date_minute 60	4/28/14 6:20:55.000 PM		182.236.164.11 -- [28/Apr/2014:18:20:56] "POST /oldlink?itemId=EST-16&SESSIONID=SD6SL8FF10ADFF53101 HTTP 1.1" 408 893 "http://www.buttercupgames.com/product.screen?productid=SF-BVS-G01" Mozilla/5.0 (Macintosh; Intel Mac OS X 10_7_4) AppleWebKit/536.5 (KHTML, like Gecko) Chrome/19.0.1084.46 Safari/536.5	182.236.164.11 -- [28/Apr/2014:18:20:56] "POST /oldlink?itemId=EST-16&SESSIONID=SD6SL8FF10ADFF53101 HTTP 1.1" 408 893 "http://www.buttercupgames.com/product.screen?productid=SF-BVS-G01" Mozilla/5.0 (Macintosh; Intel Mac OS X 10_7_4) AppleWebKit/536.5 (KHTML, like Gecko) Chrome/19.0.1084.46 Safari/536.5

FIG. 8A

Data Summary			
Hosts (5)		Sourcetypes (3)	
filter			
Host	Host Count	Count	Last Update
mailsv	mailsv	9,829	4/29/14 1:32:47.000 PM
vendor_sales	mailsv	30,244	4/29/14 1:32:46.000 PM
www1	mailsv	24,221	4/29/14 1:32:44.000 PM
www2	mailsv	22,595	4/29/14 1:32:47.000 PM
www3	mailsv	22,975	4/29/14 1:32:45.000 PM

FIG. 8B

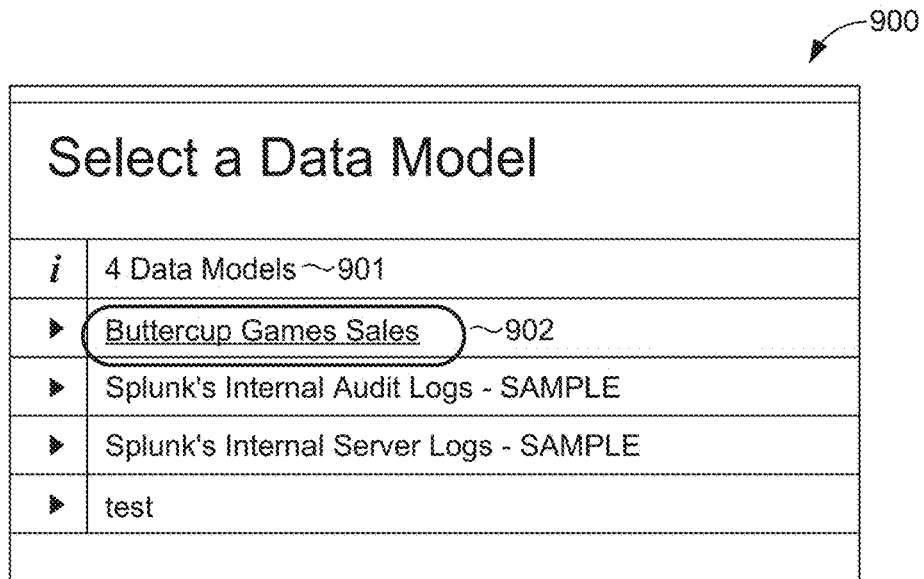

FIG. 9

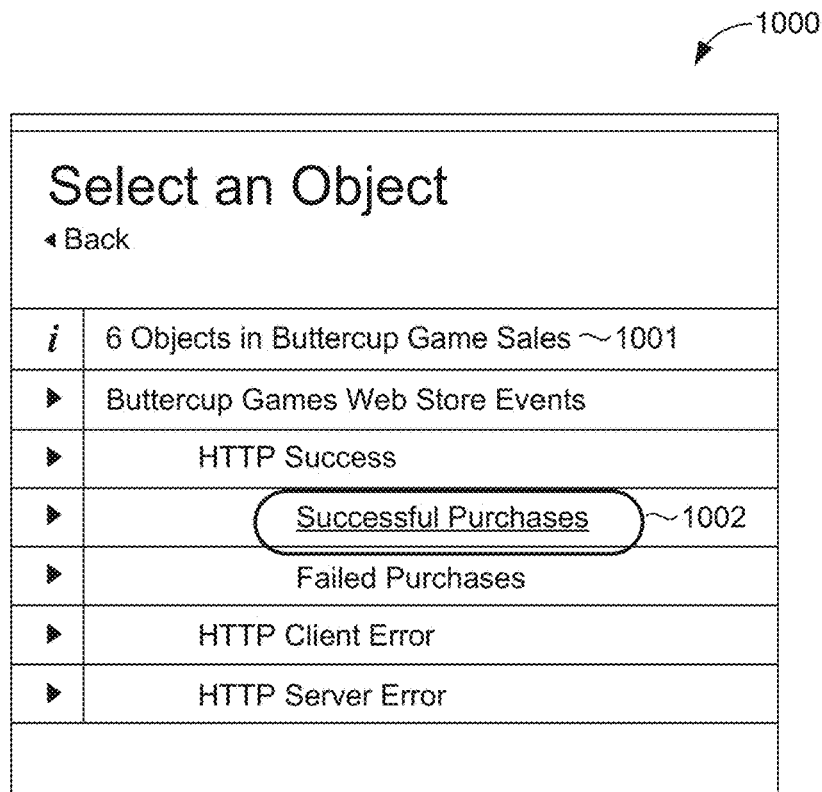

FIG. 10

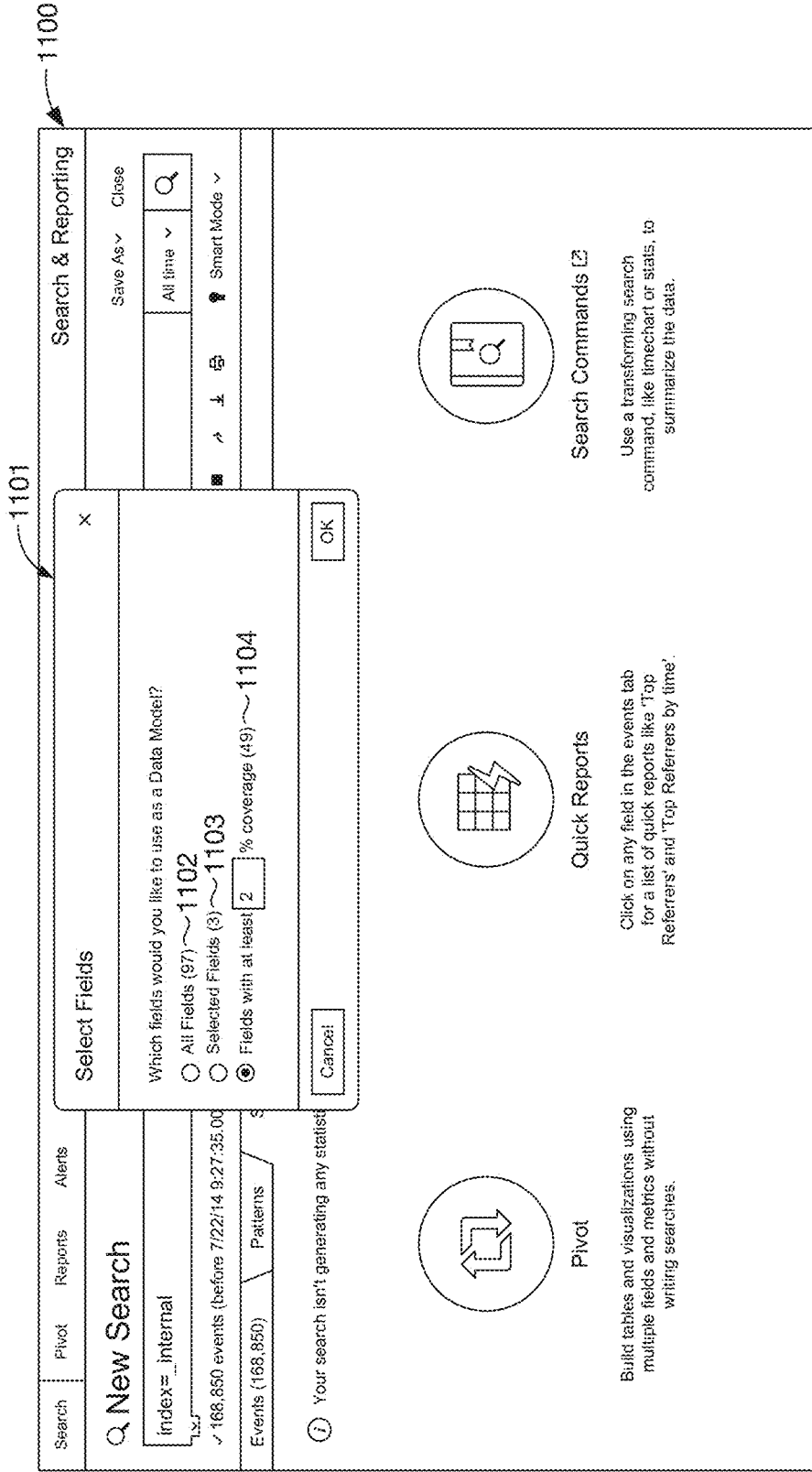

FIG. 11A

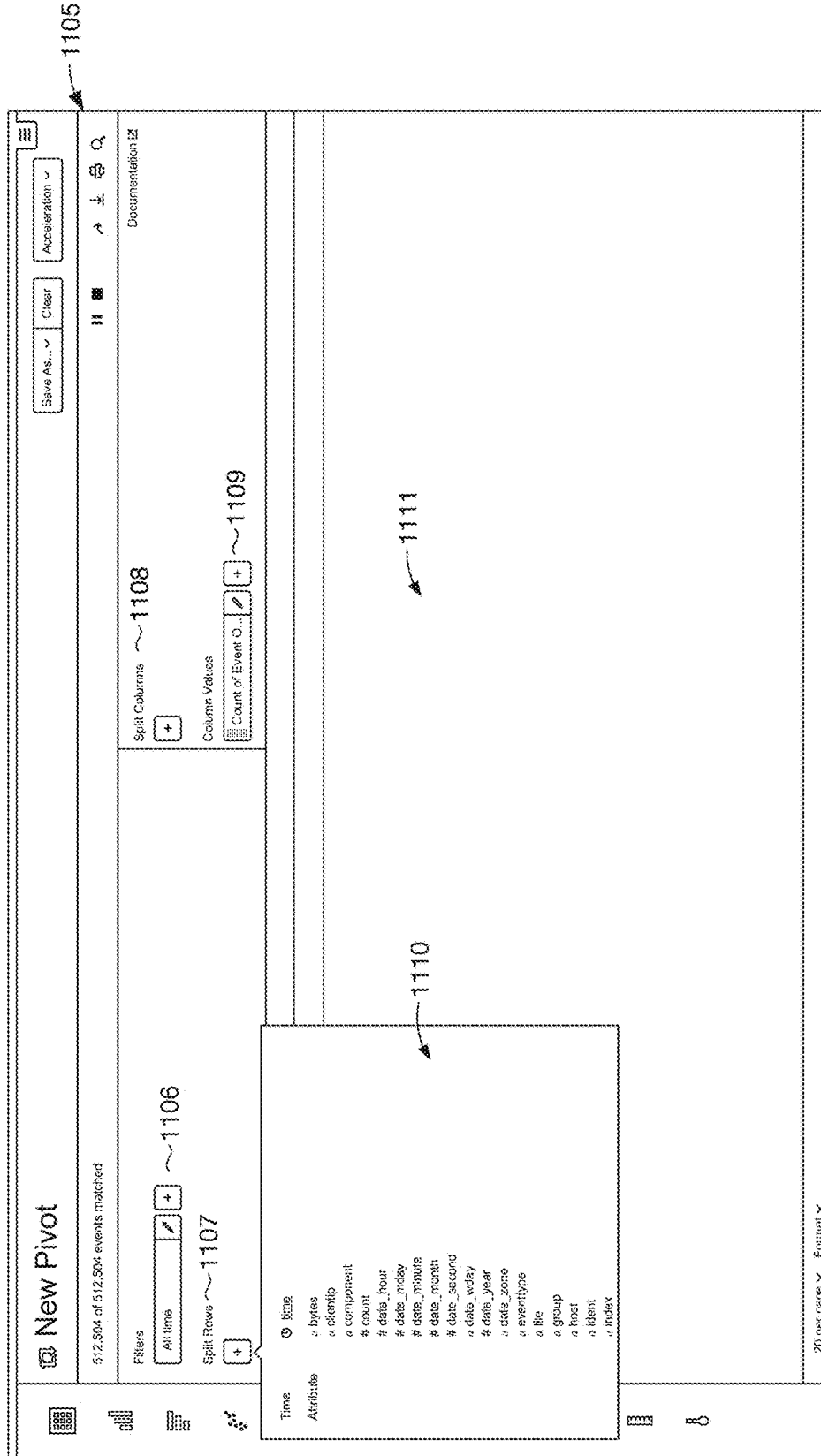

FIG. 11B

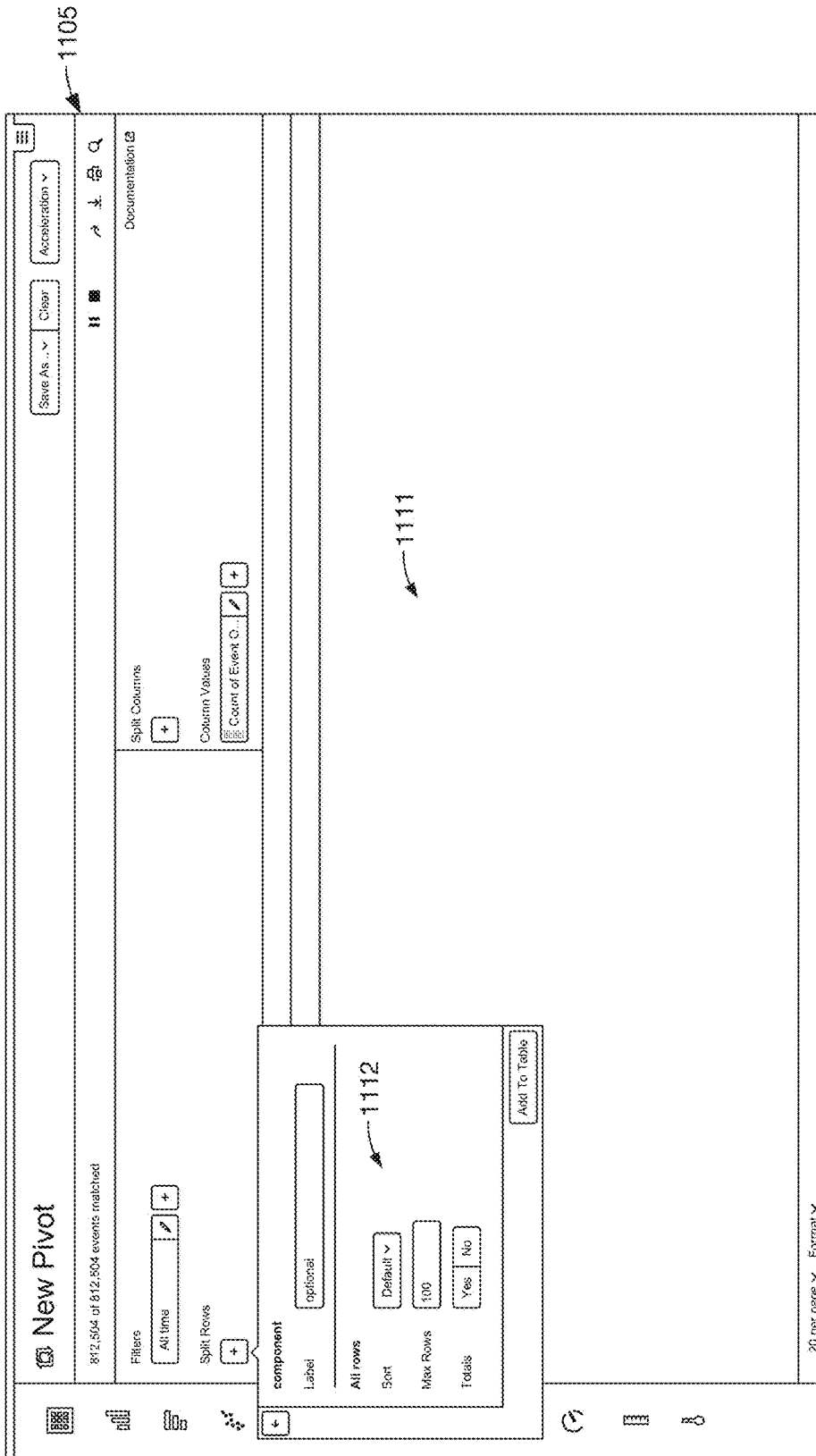

FIG. 11C

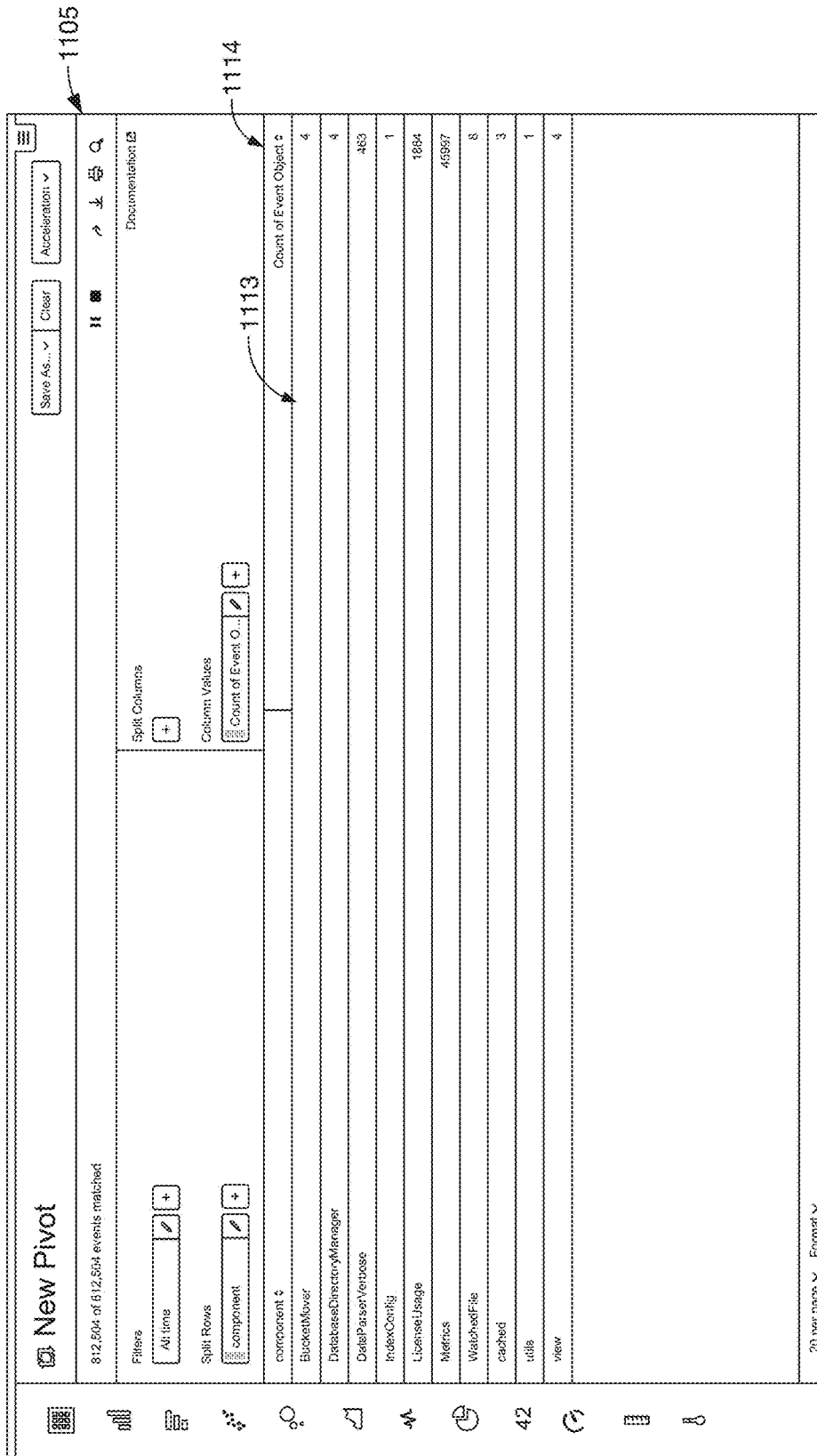

FIG. 11D

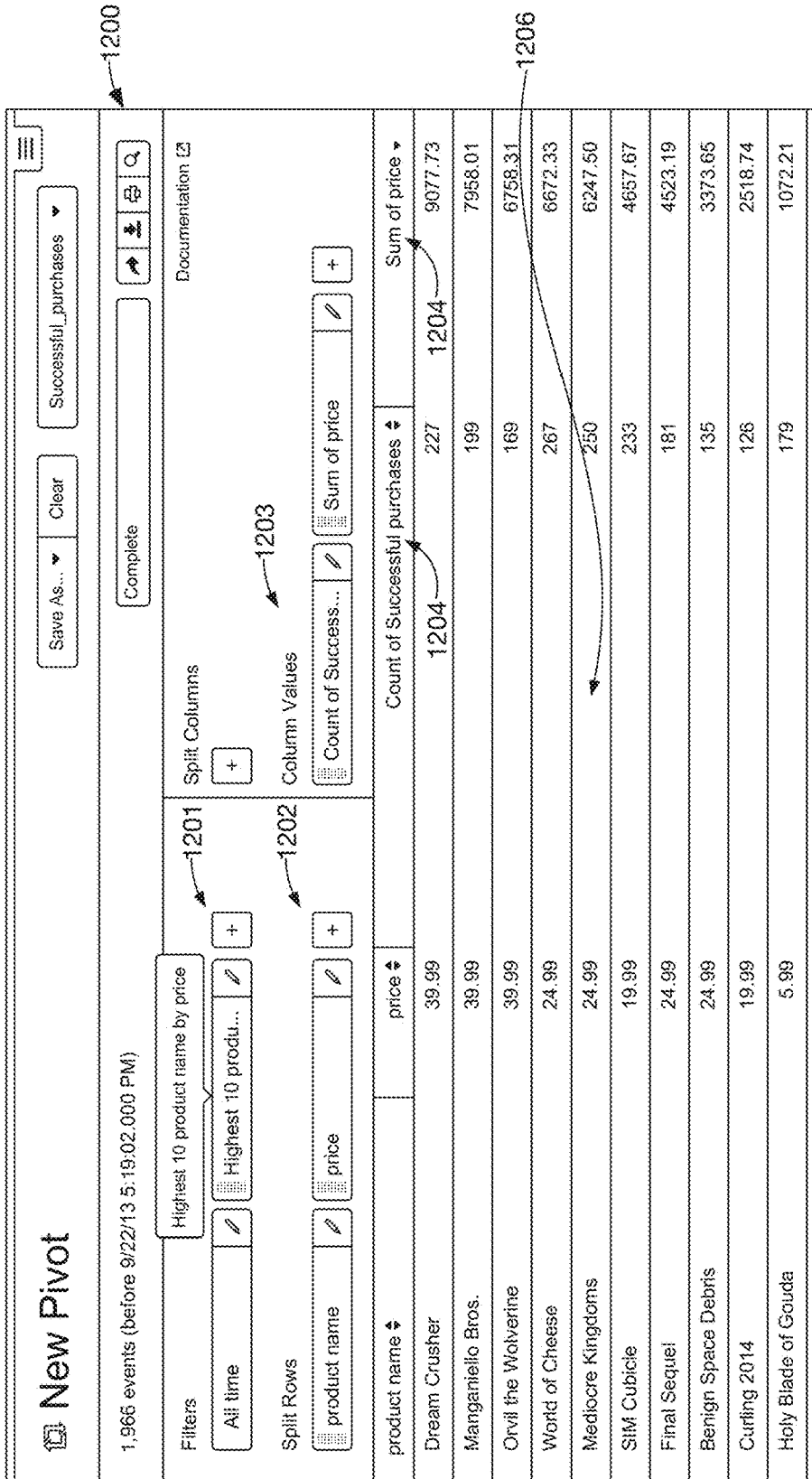

FIG. 12

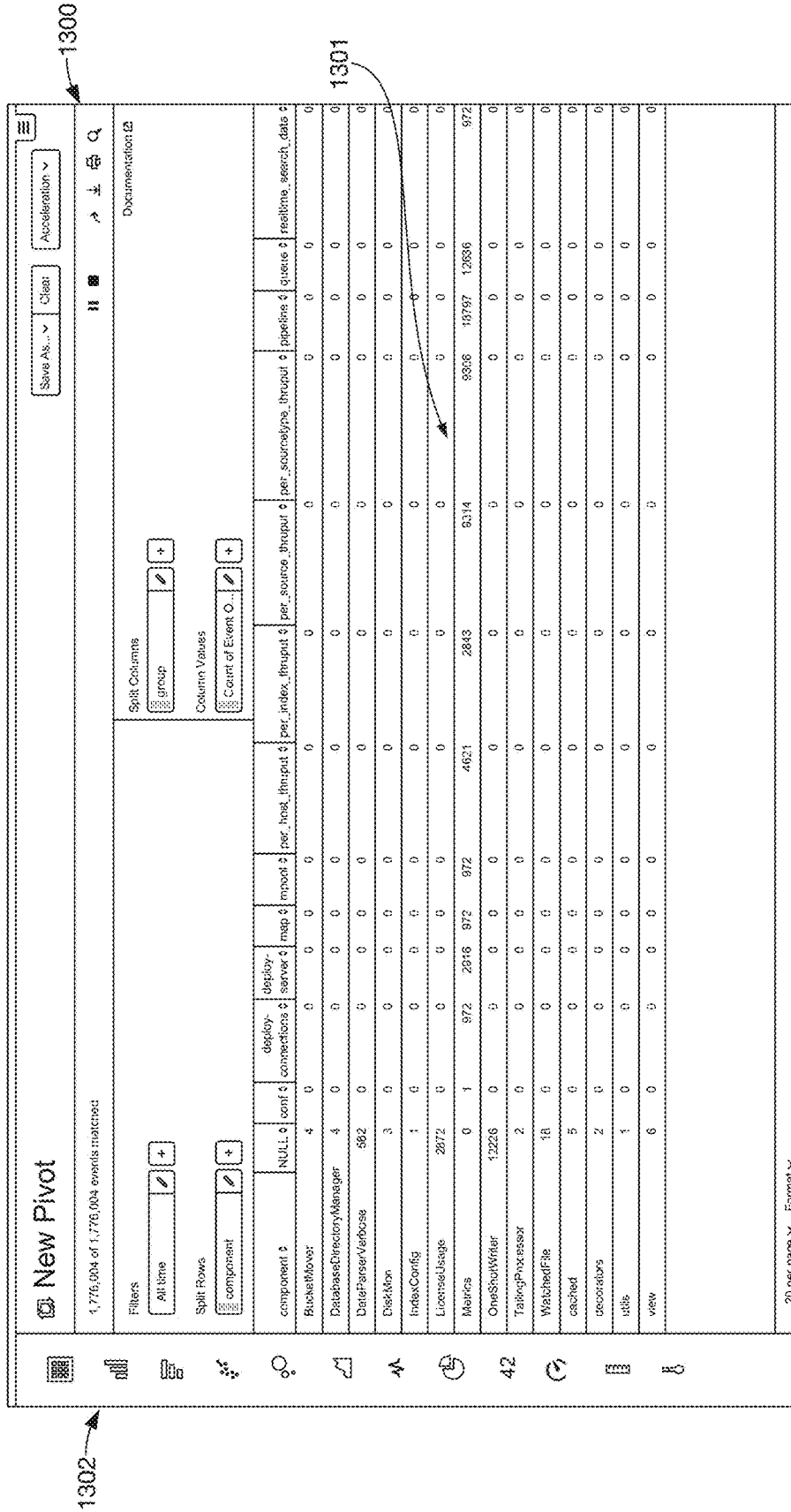

FIG. 13

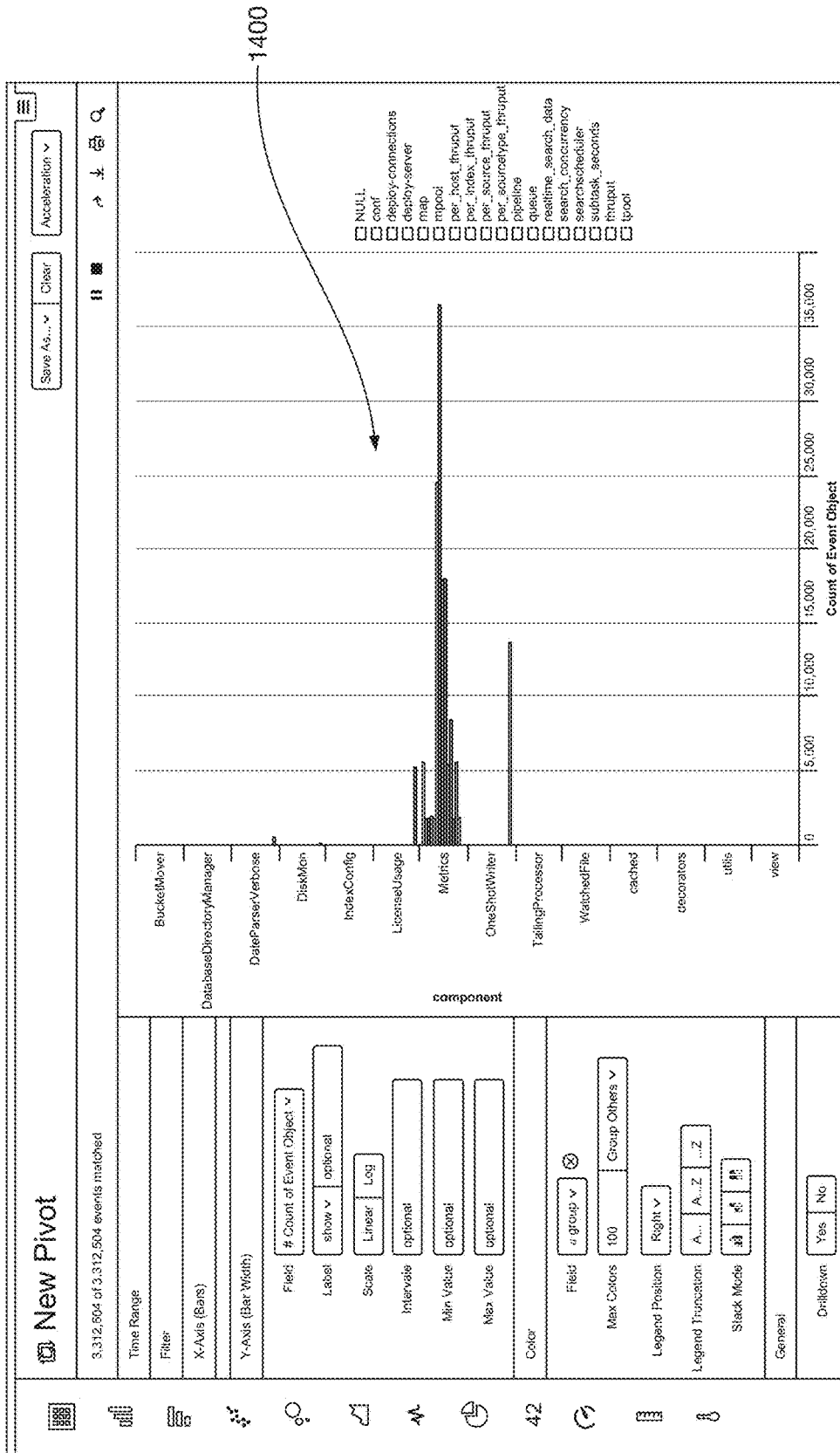

FIG. 14

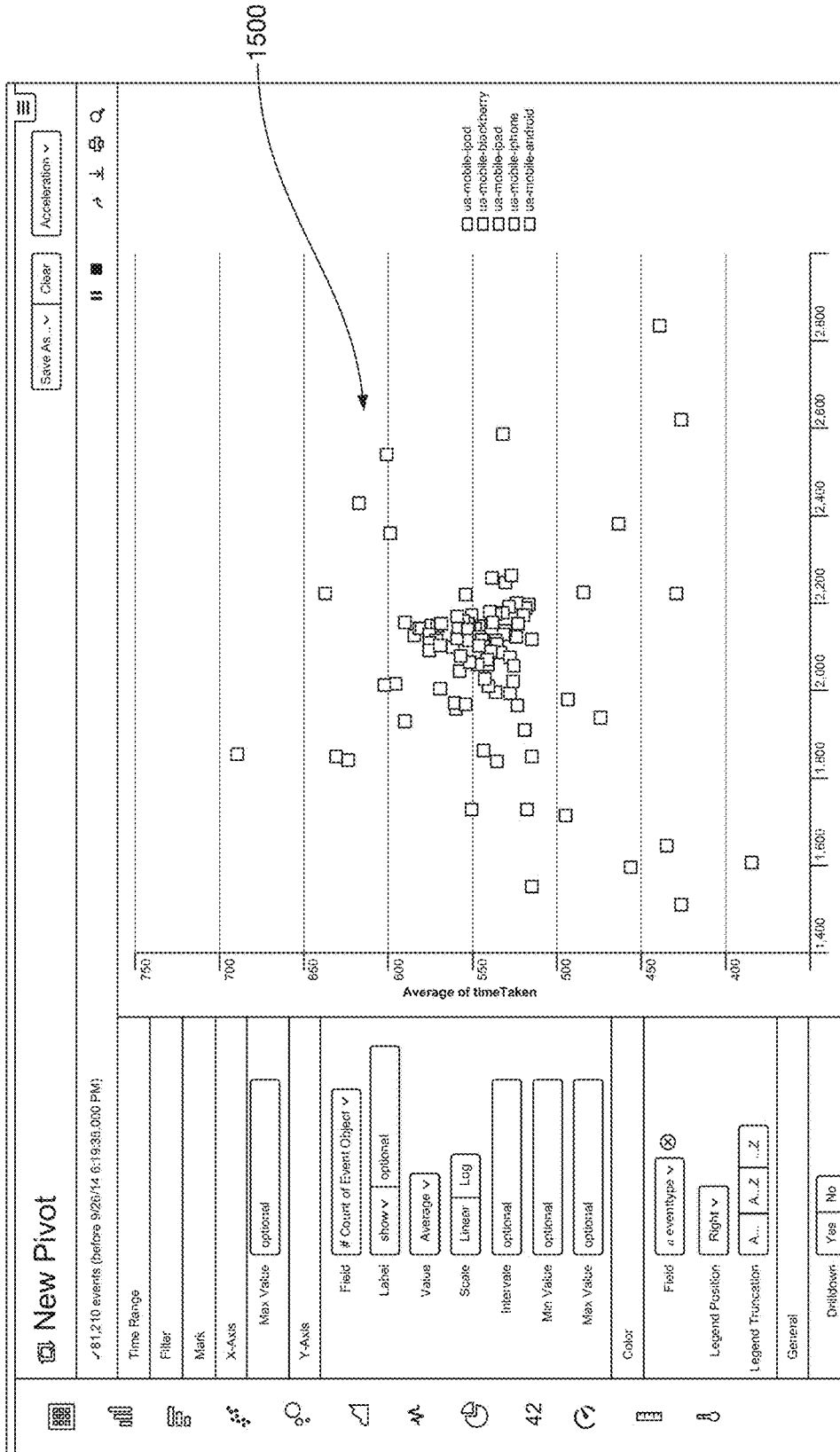

FIG. 15

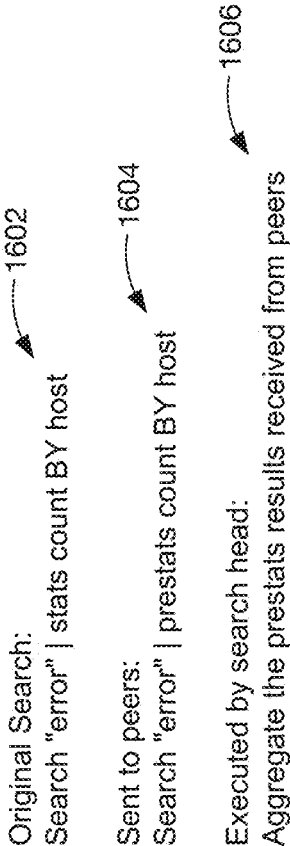

FIG. 16

KEY INDICATORS VIEW 1700

ACCESS NOTABLES Total Count	ENDPOINT NOTABLES Total Count	NETWORK NOTABLES Total Count	IDENTITY NOTABLES Total Count	AUDIT NOTABLES Total Count
45 ↑ +45	61 ↑ +61	15 ↑ +15	2 ↑ +2	32 ↑ +32

1701

MALWARE INFECTIONS Total Count	VULNERABLE HOSTS Total Count	VULNERABILITIES / HOST AVG Medium Severity Or Higher	HOSTS FULLY PATCHED Percent Of Total Hosts
632 ↑ +63	1452 ↓ -74	1.6 ↓ -0.2	78.3% ↑ +0.2

1702

1703

NOTABLE EVENTS BY URGENCY

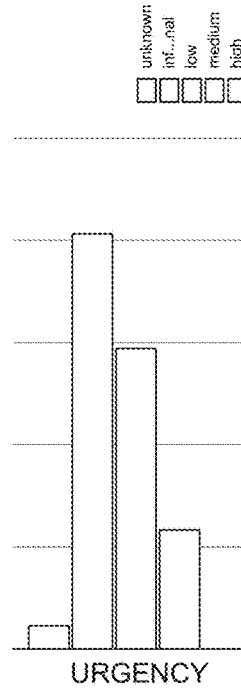

1704

NOTABLE EVENTS BY TIME

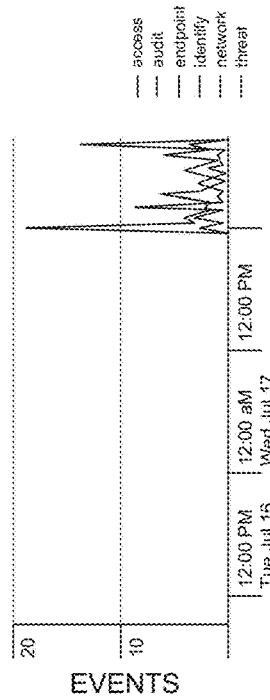

FIG. 17A

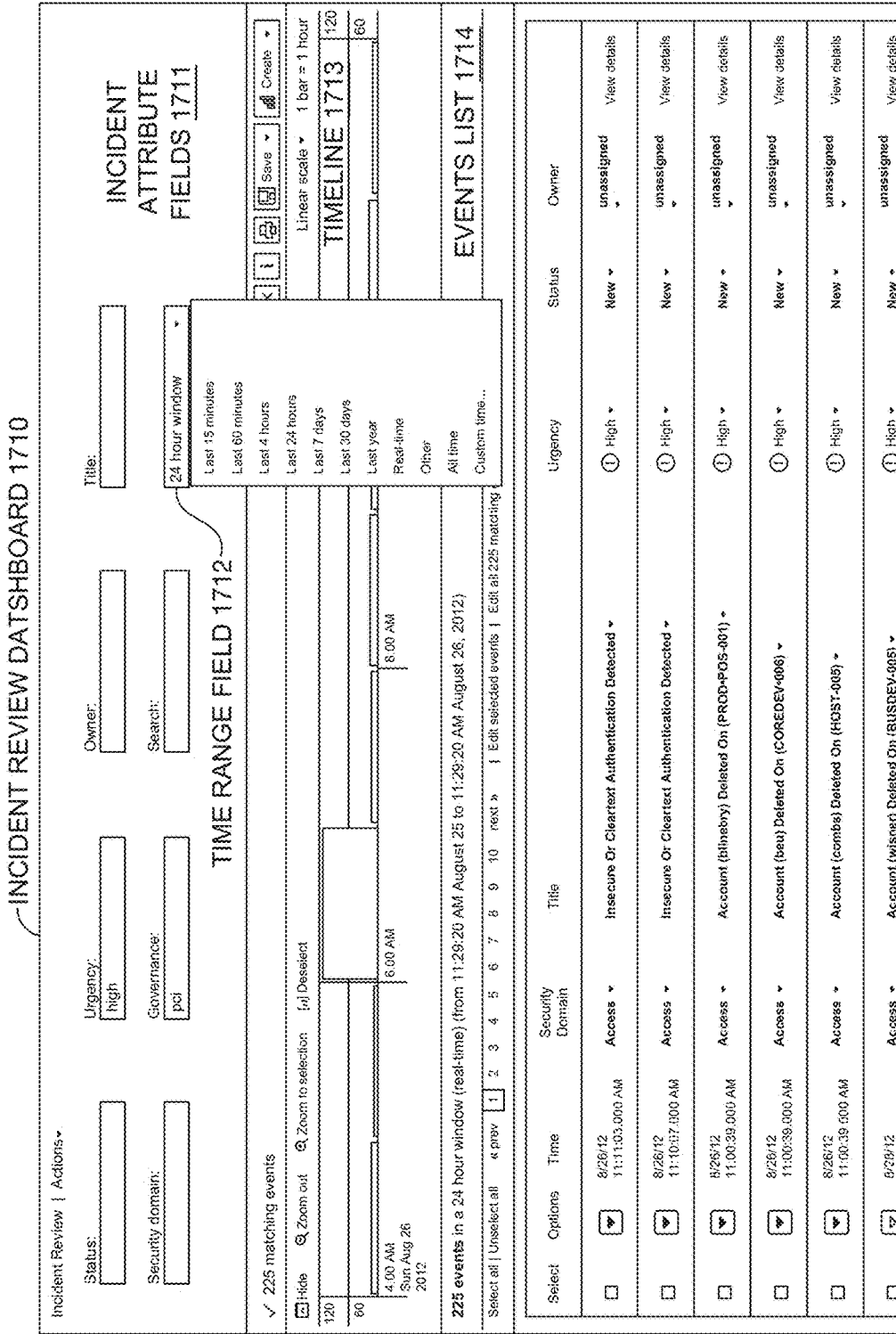

FIG. 17B

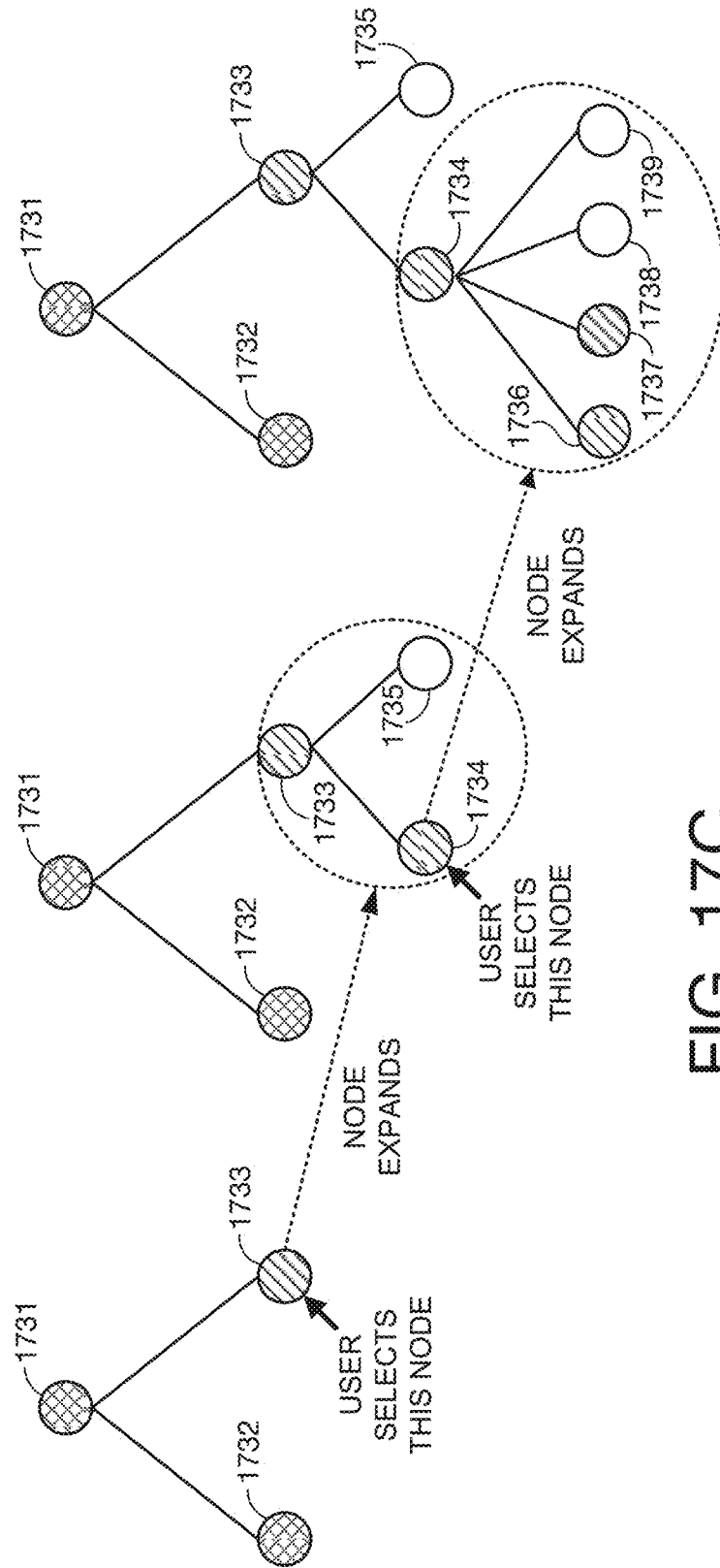

FIG. 17C

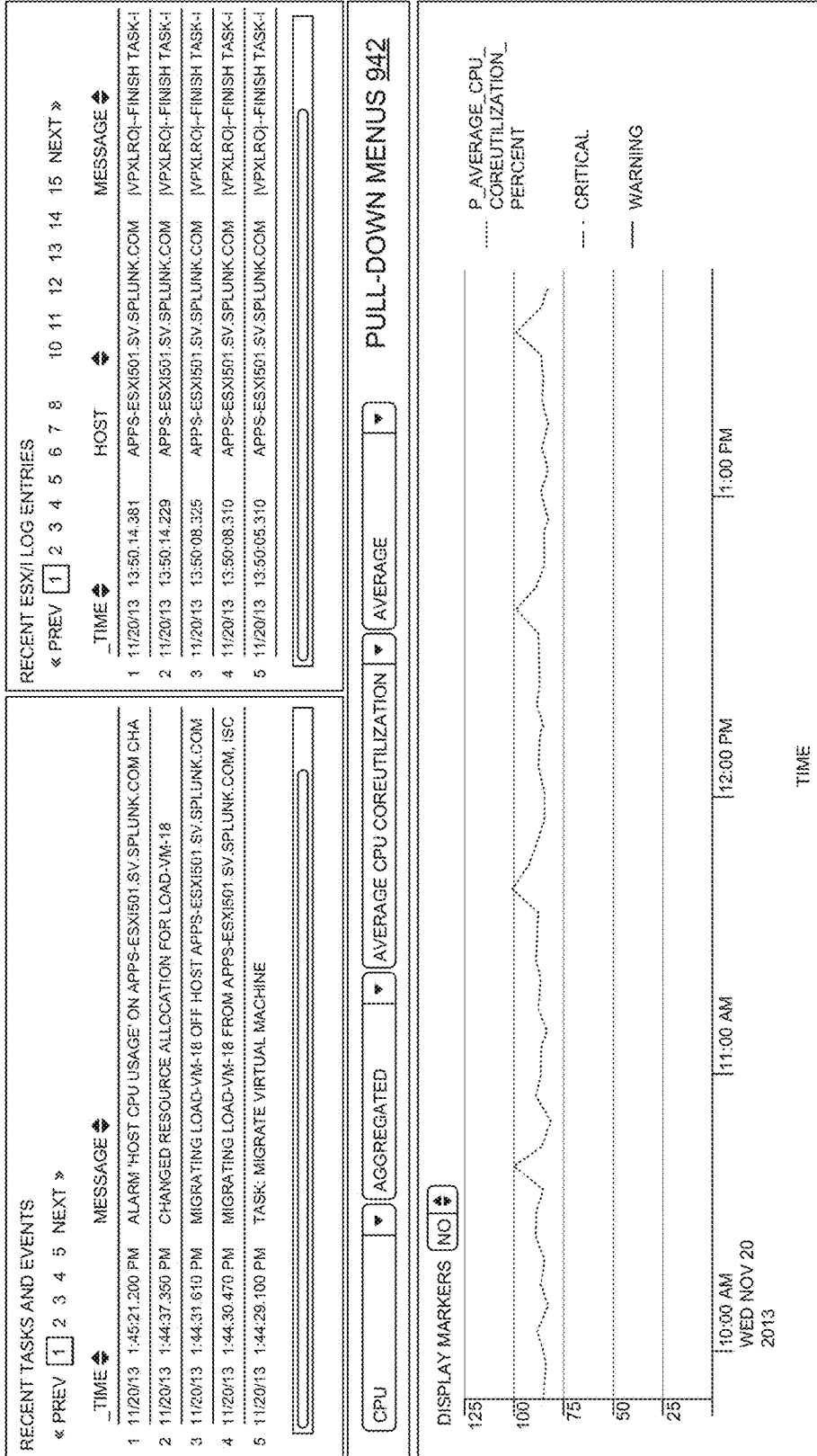

FIG. 17D

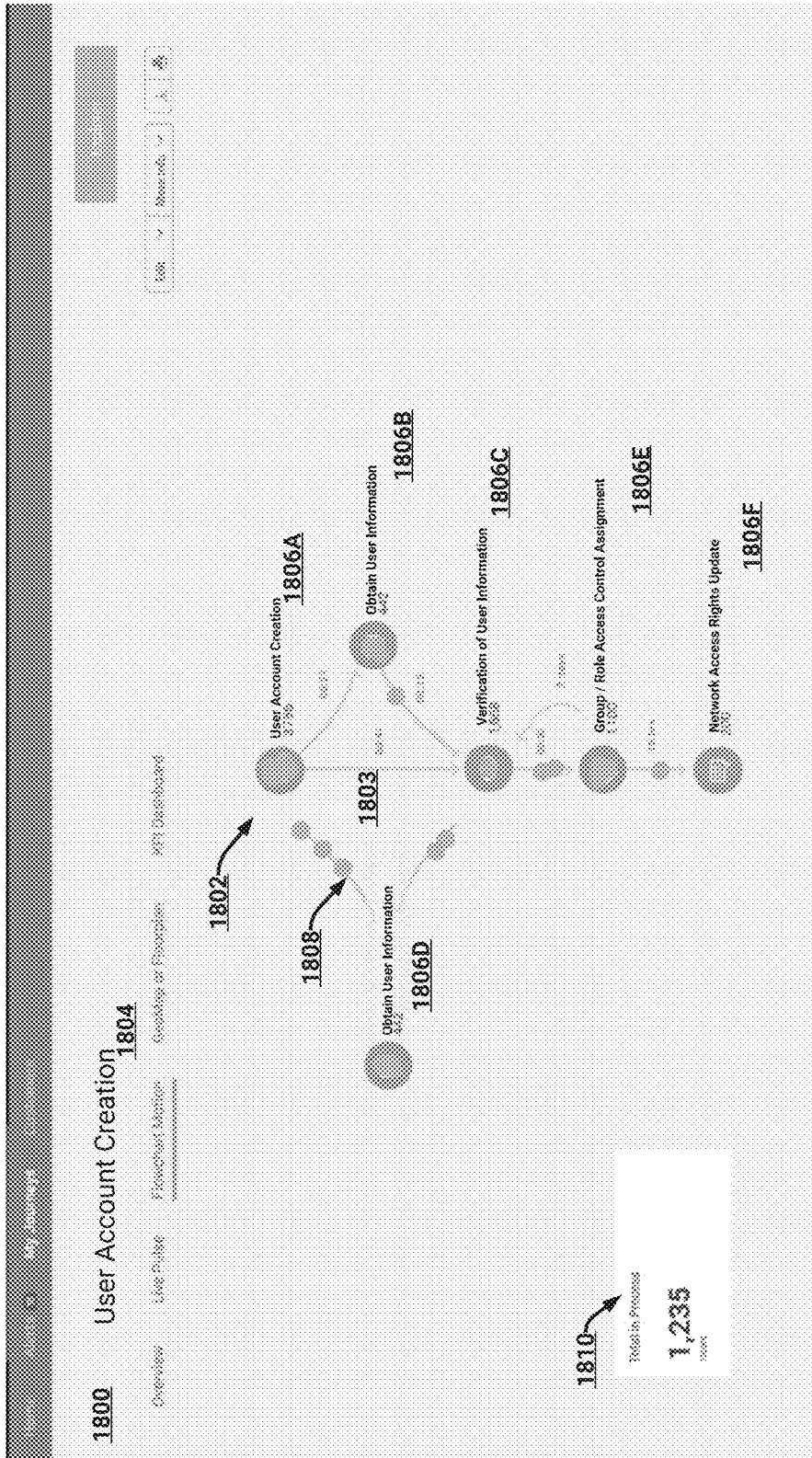

FIG. 18

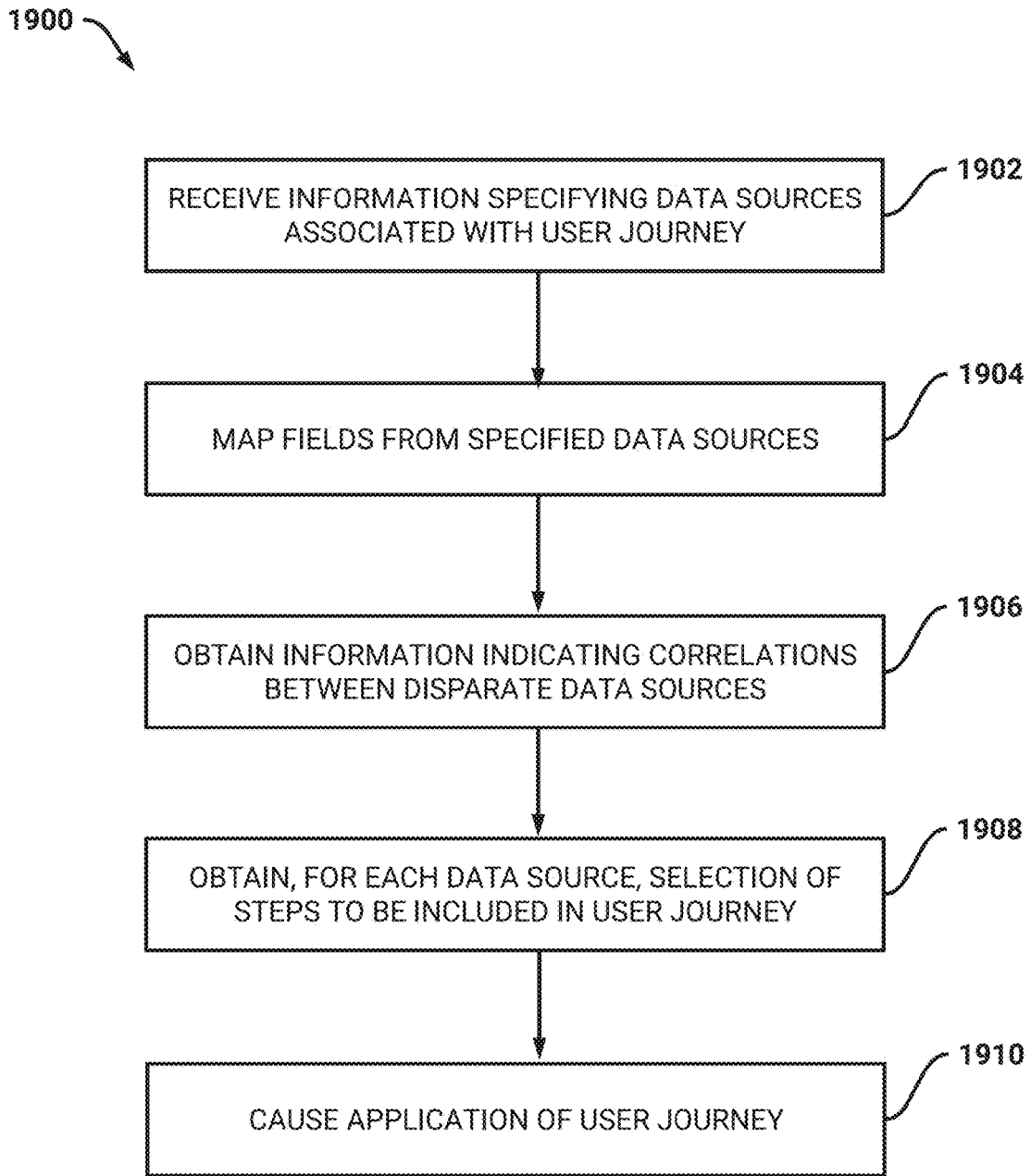
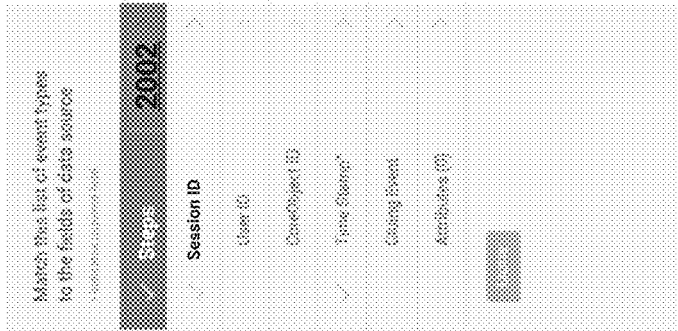
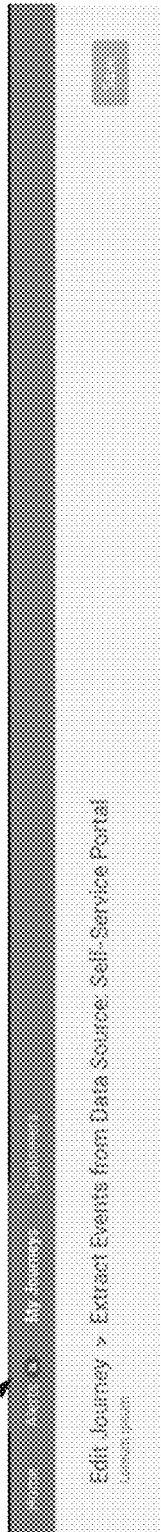

FIG. 19

2000



Select fields which represent Steps



FIG. 20

Text

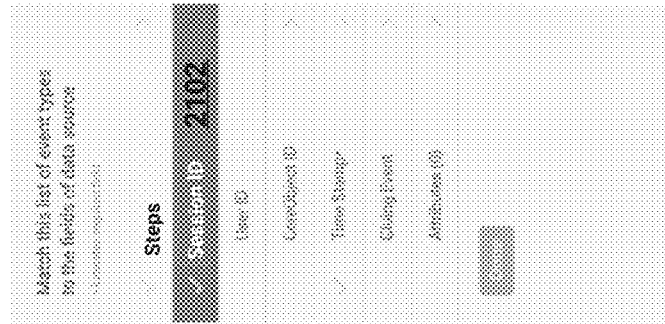
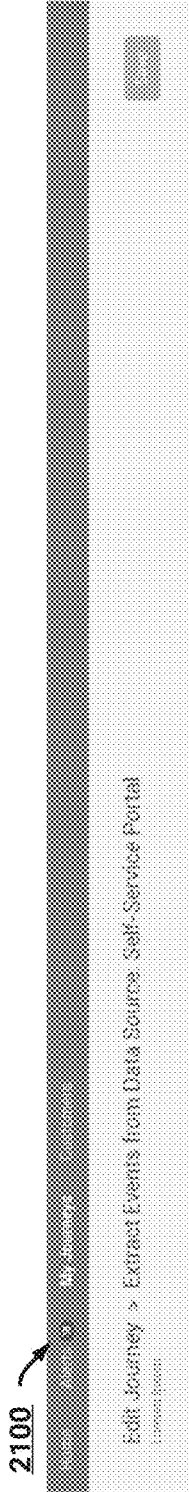

Select fields which represent Session ID

Fields in Data Source	Top 10 Values for SessionsID
<input checked="" type="checkbox"/> SessionsID 2104	
<input type="checkbox"/> procedureID	Value: 180-287-0294 Count: 2,325 %: 8.673%
<input type="checkbox"/> host	Value: 180-007-0294 Count: 2,325 %: 8.673%
<input type="checkbox"/> .zone	Value: 180-504-0294 Count: 2,325 %: 8.673%
<input type="checkbox"/> codeID	Value: 180-504-0294 Count: 2,325 %: 8.673%
<input type="checkbox"/> action	Value: 180-554-0294 Count: 2,325 %: 8.673%
4. Add more fields	

FIG. 21



FIG. 22



FIG. 23

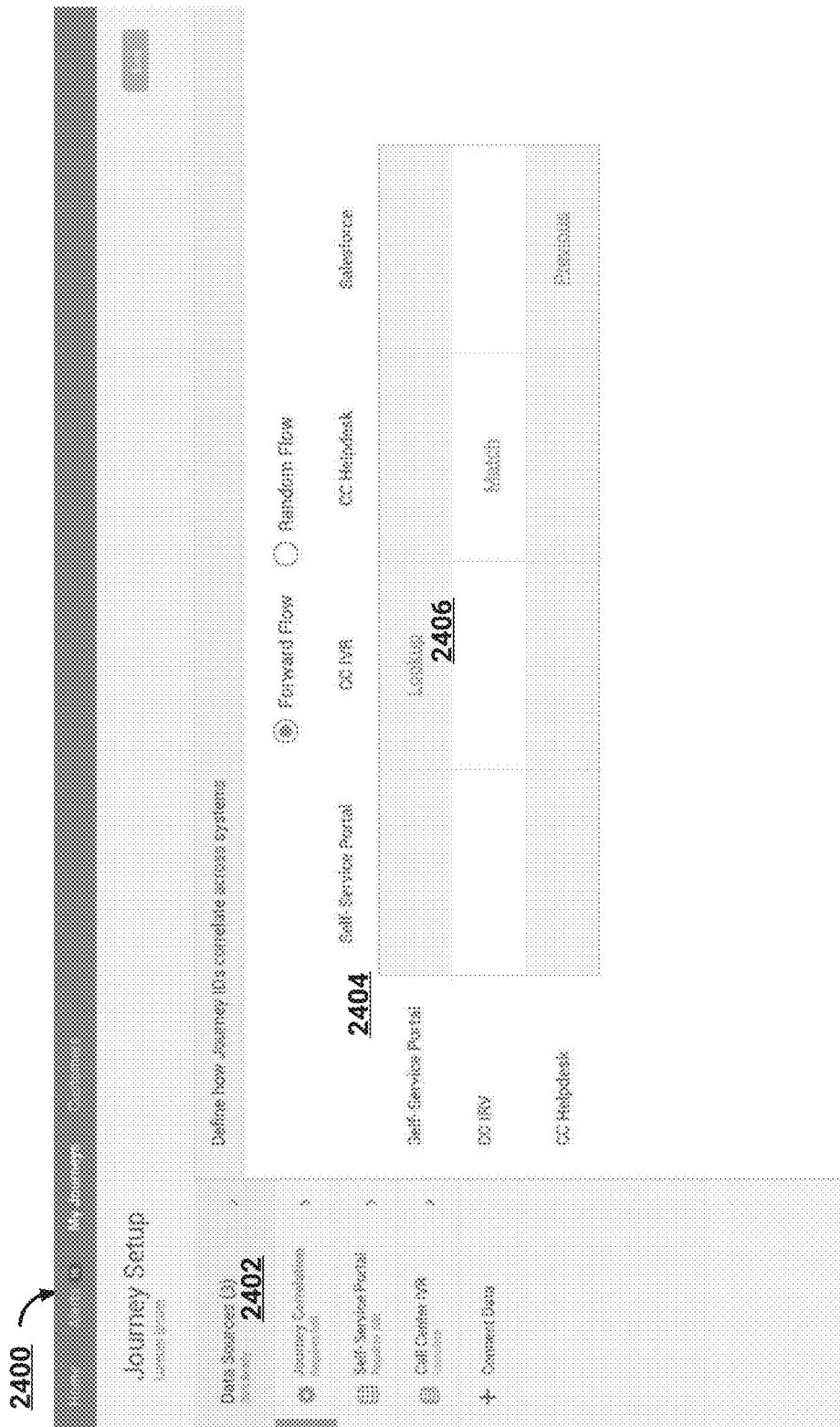

FIG. 24

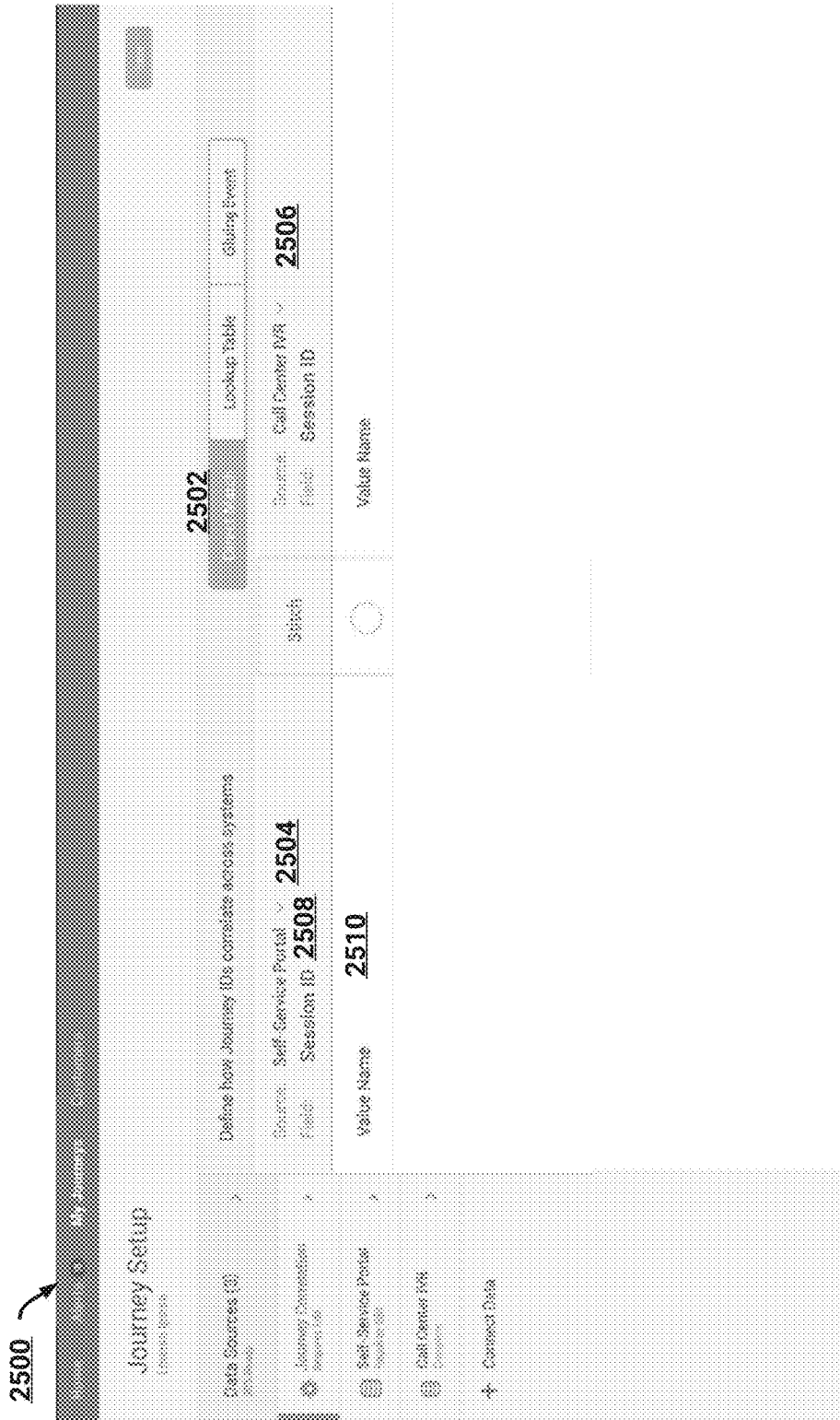

FIG. 25

2600



The screenshot displays a 'Journey Setup' interface with a navigation bar at the top containing 'Home', 'My Journeys', and 'Correlations'. The main content area is divided into two sections:

- Left Section:** Titled 'Journey Setup' with a sub-header 'Define how Journey IDs correlate across systems'. It lists three data sources: 'Data Sources (3)', 'Journey Correlations', 'Call Center Portal', and 'Call Center NVR'. A '+ Connect Data' button is located at the bottom.
- Right Section:** A configuration area for a correlation rule. It includes a 'Direct Match' dropdown set to 'Gluing Event'. Below this, a 'Source' dropdown is set to 'Call Center NVR' and a 'Field' dropdown is set to 'CallentID'. A 'Match' button with a bidirectional arrow is positioned between the two sections. A 'Value Name' field is present at the bottom of the configuration area.

2602

2604

2608

2612

2606

2610

FIG. 26

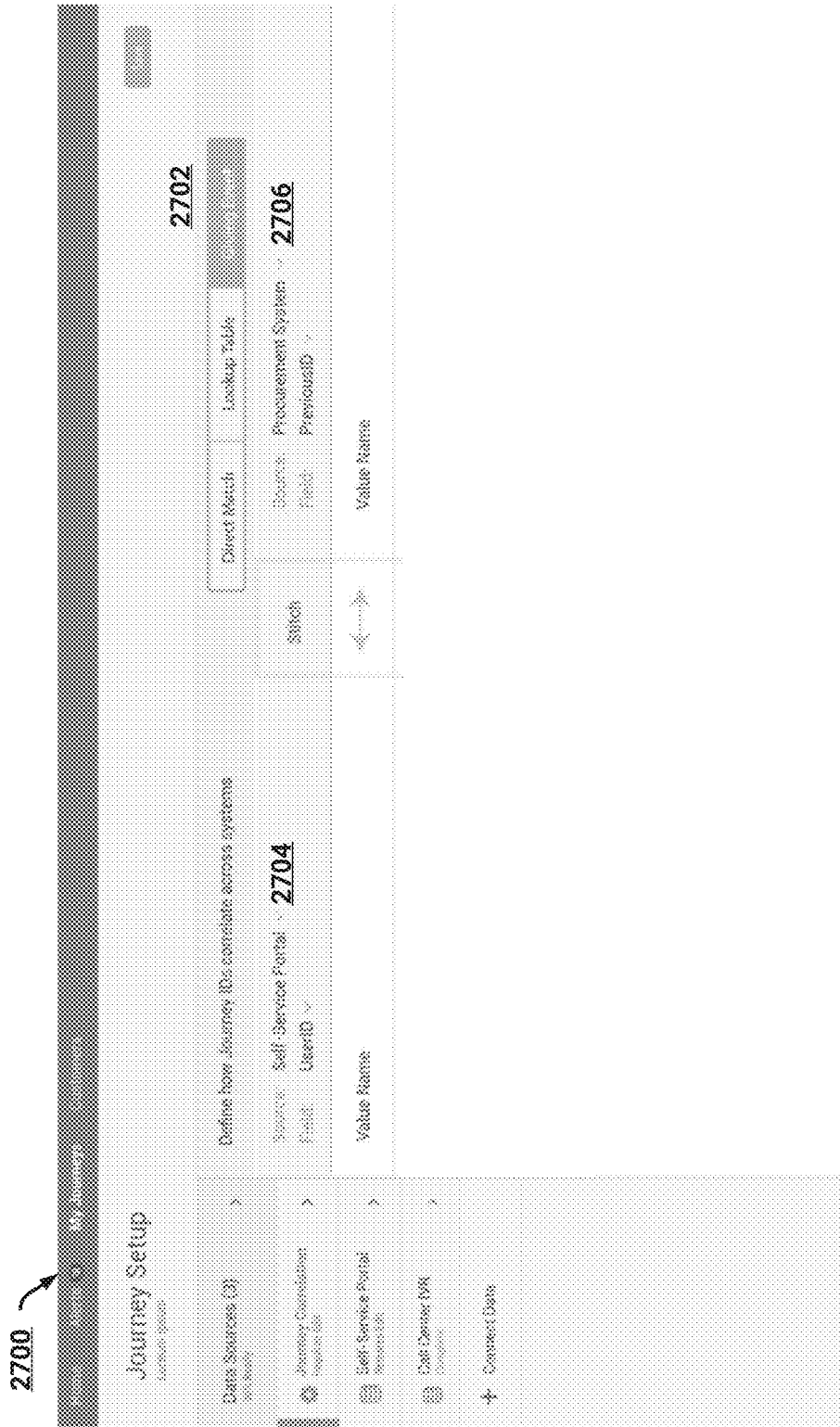

FIG. 27

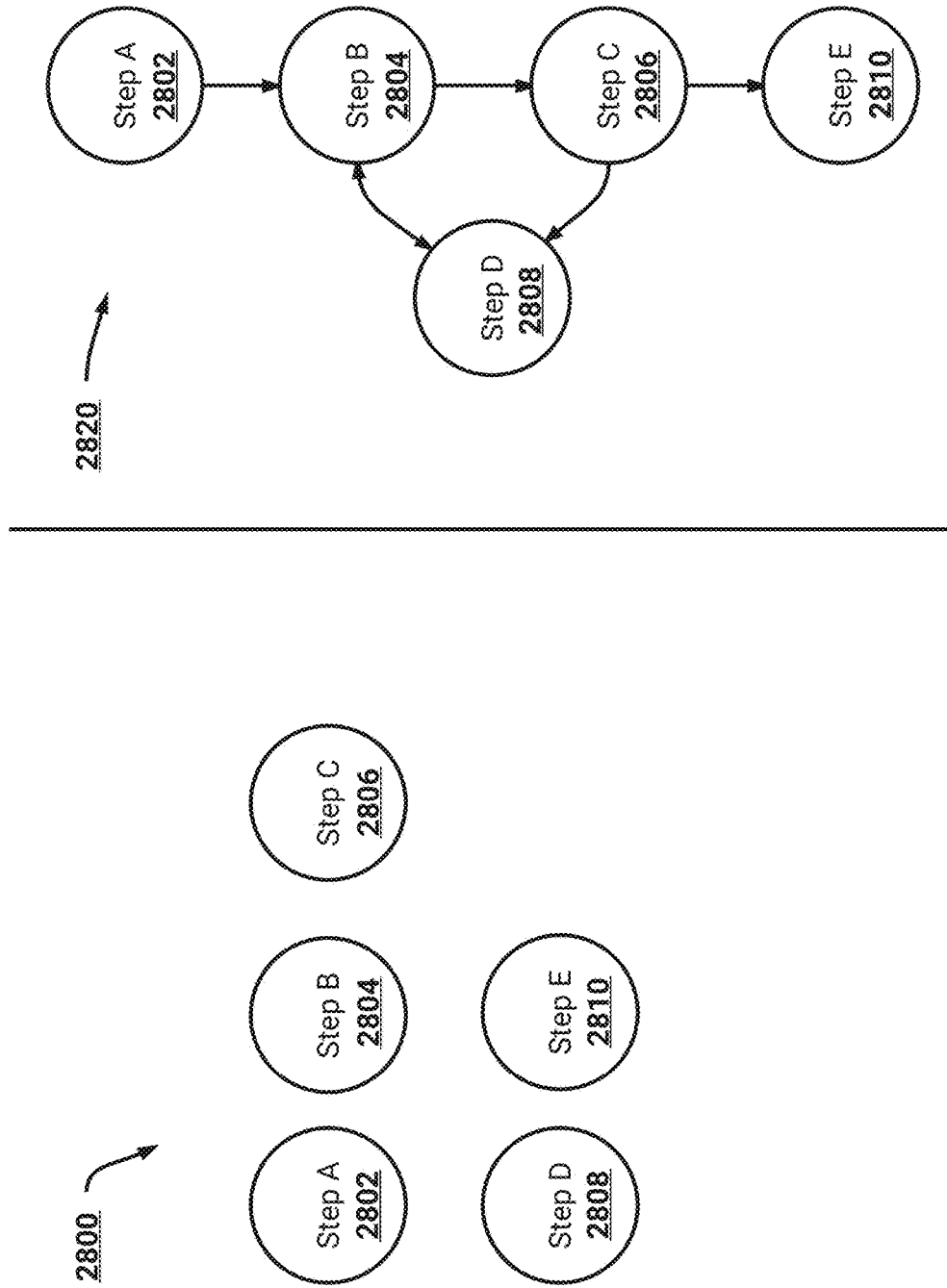

FIG. 28

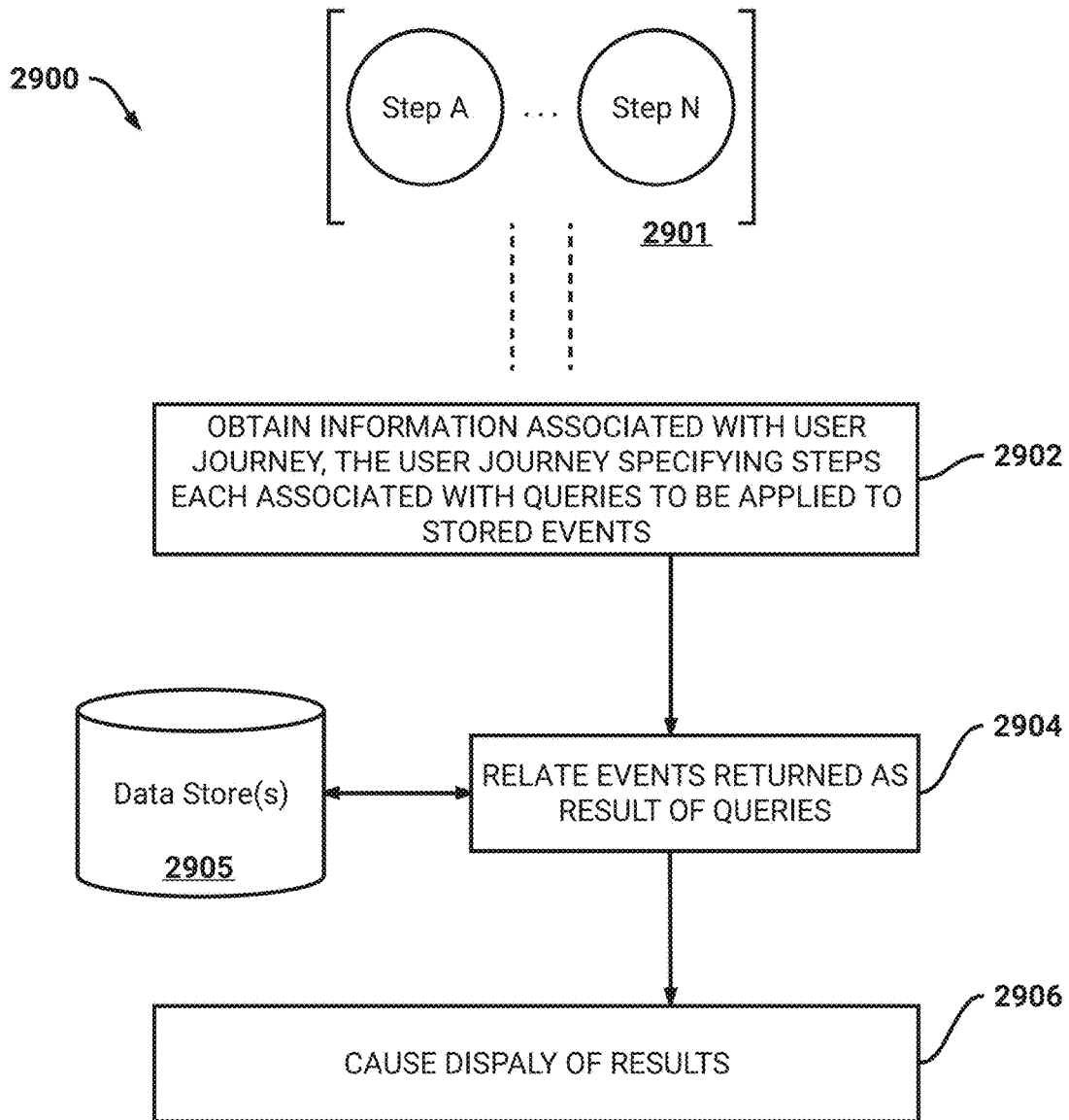

FIG. 29

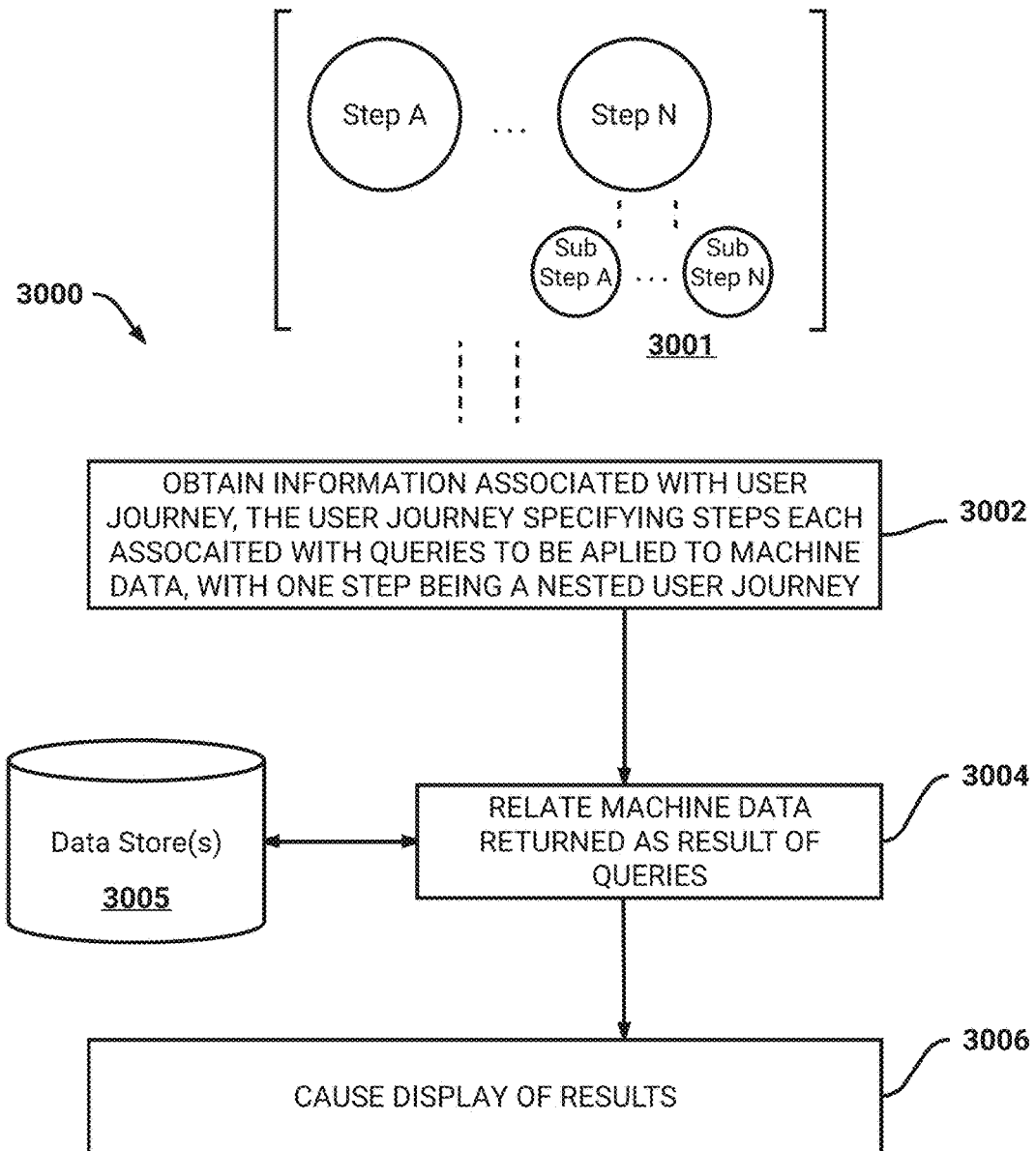

FIG. 30

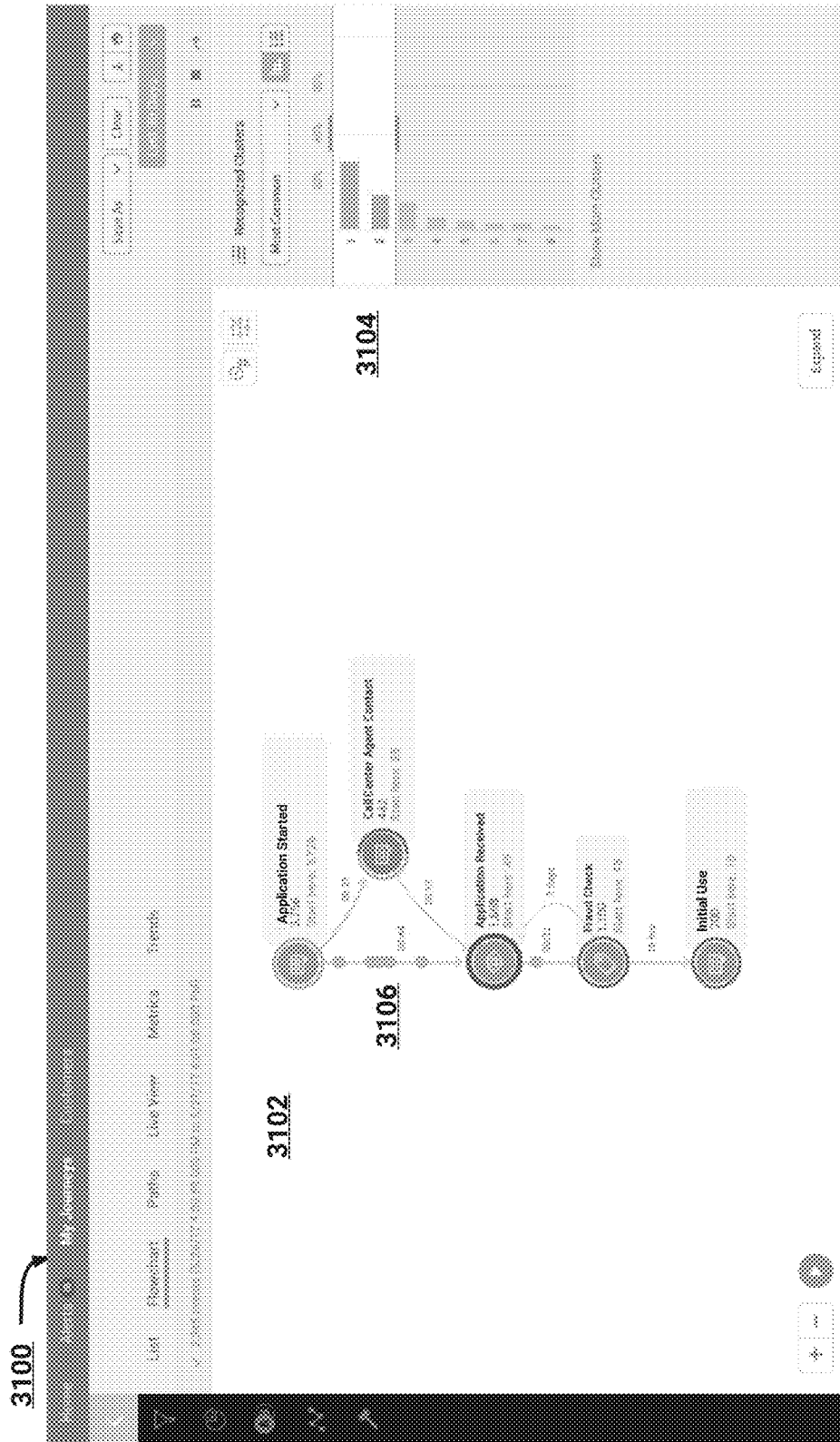

FIG. 31

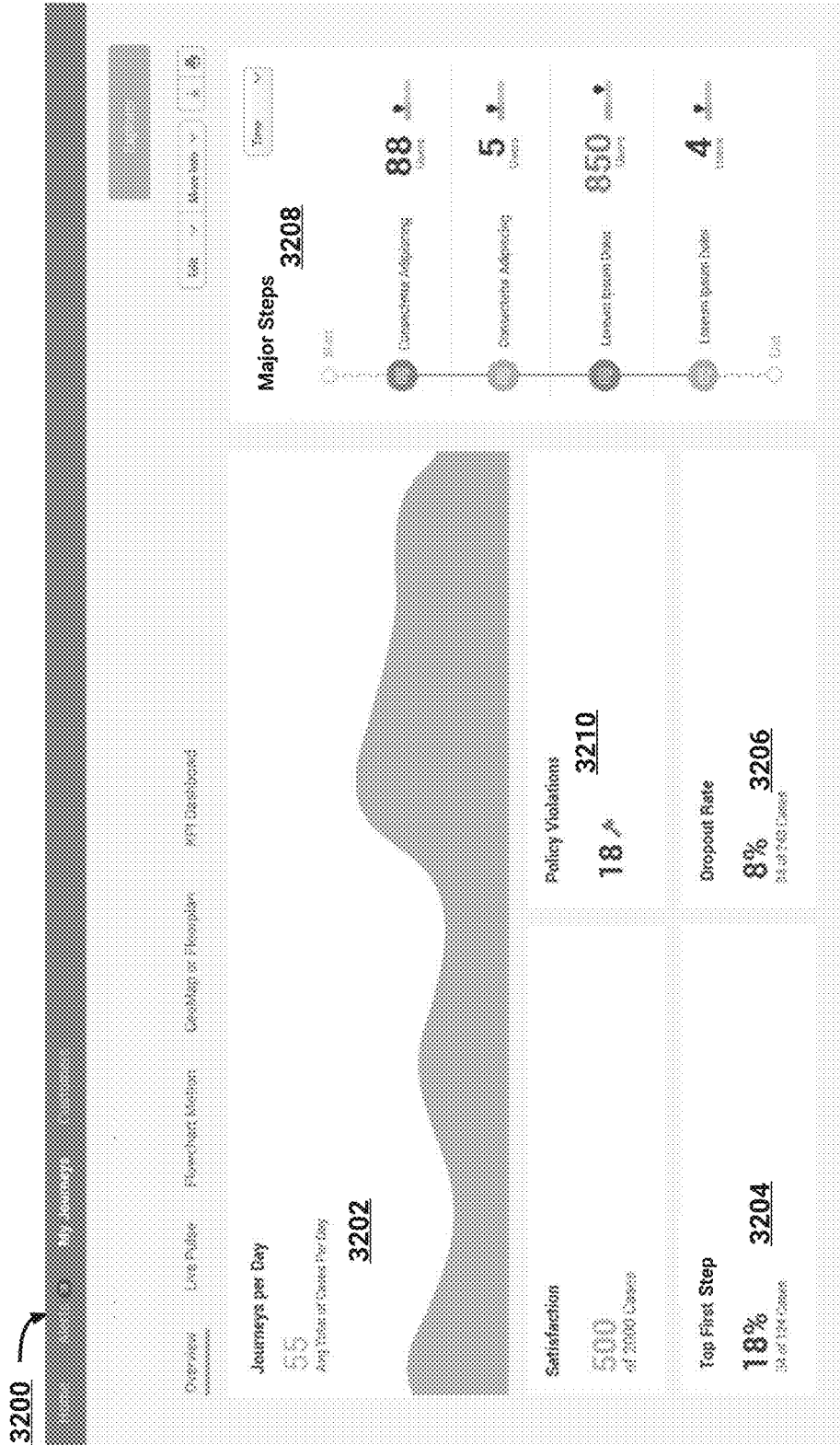

FIG. 32



FIG. 33

3400

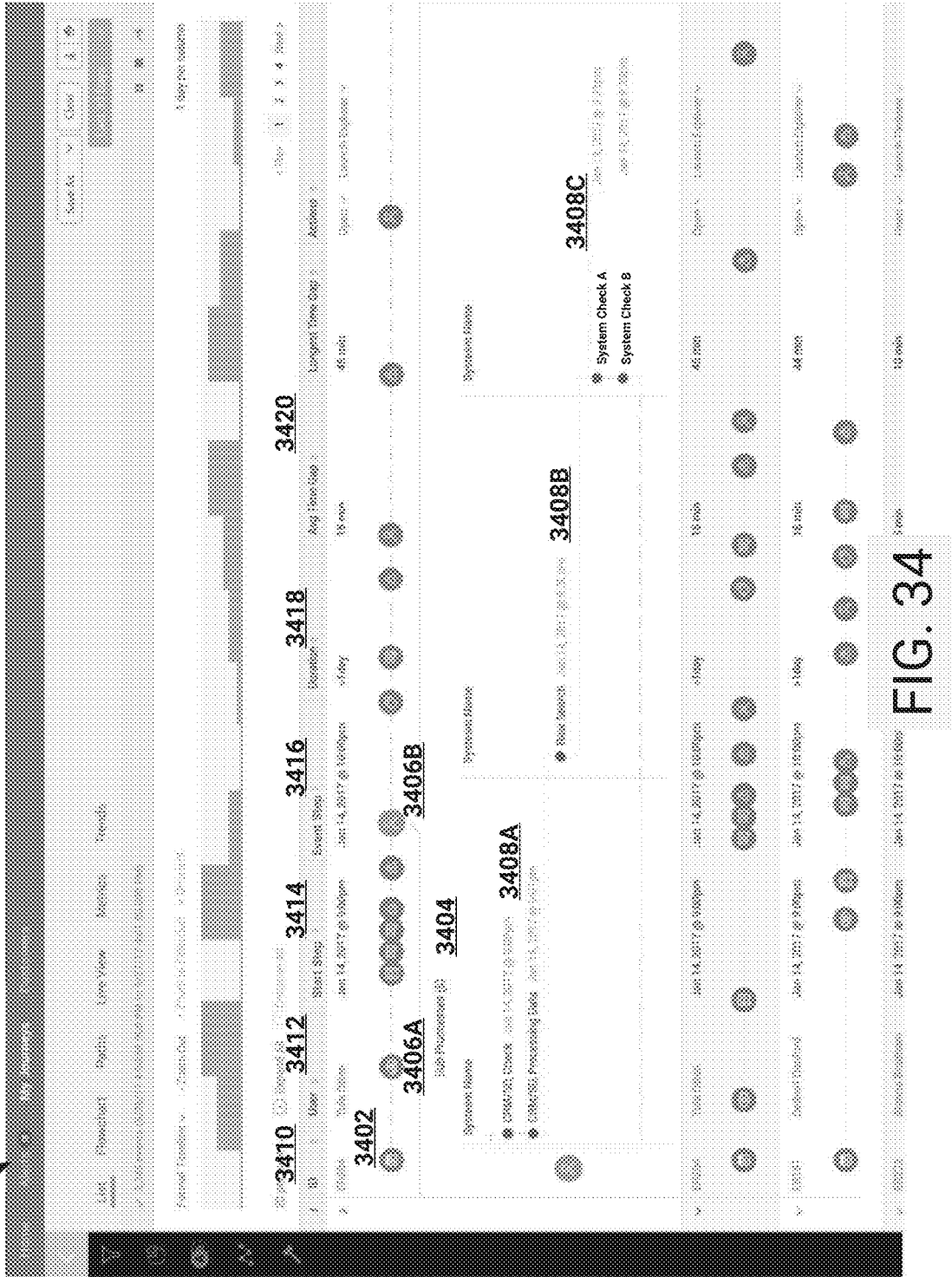

FIG. 34



FIG. 35

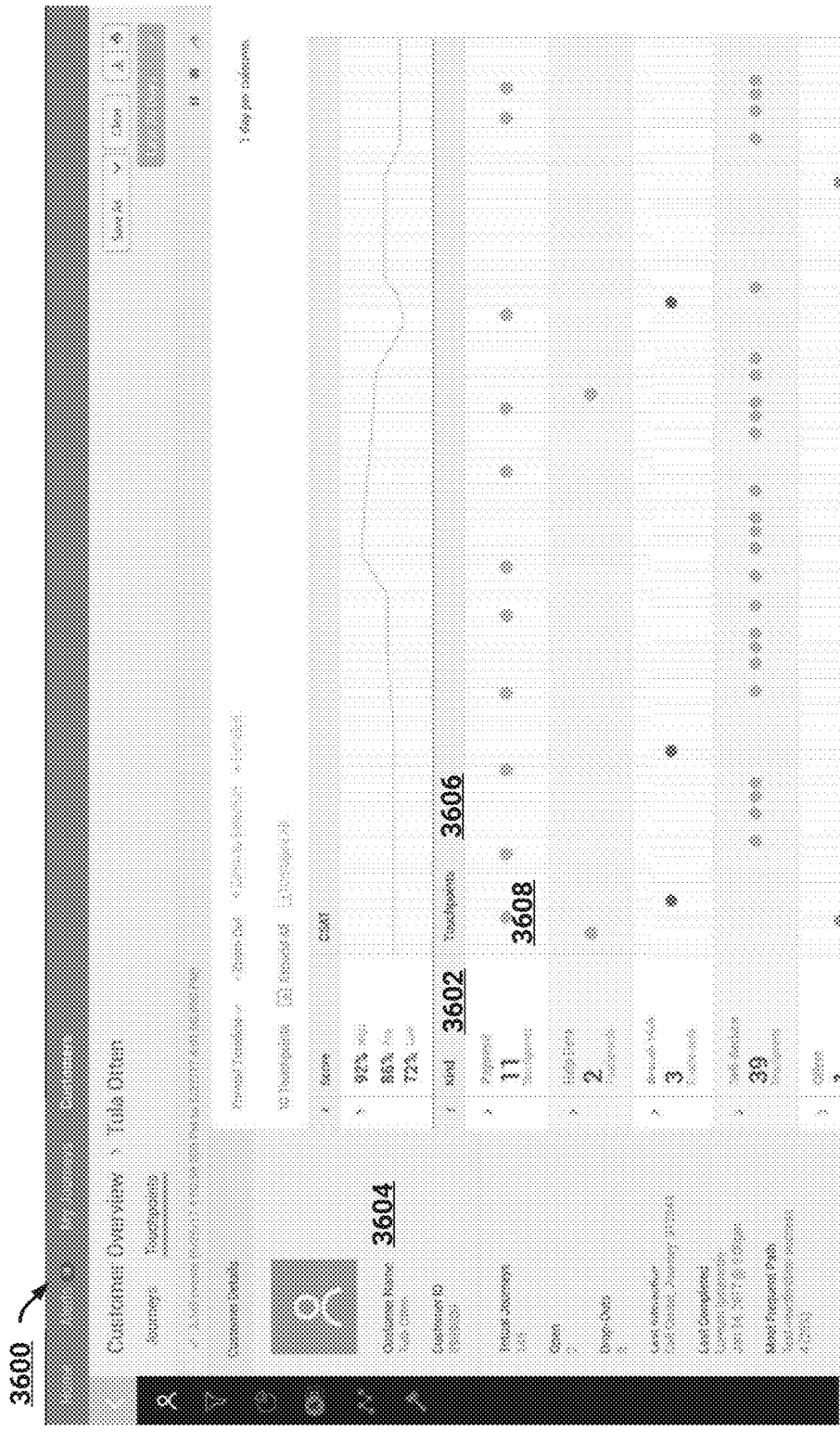

FIG. 36

3700 →

splunk> App: Journey Analytics
Administrator
Messages Settings Activity Help
Find

Journey Analytics

Event Streams

- Buttercup Games
- Guest 360 Experience
- Hotel Interactive Menu
- In-room Chromecast Expe...
- Order Process Flow
- SFDC Oppty Stage Funnel
- Sales Email
- TV CHANNELS

+ Add New

Edit: Buttercup Games

Search 3701A 3701B 3701C

Field Mapping Sessionization

3710A 3710A 3710C 3704

(Step) / (Pivot IDs (0)) / (Attributes (0)) Hide default fields

Field	Usage	Count
ident	none ▾	17
items	none ▾	17
JSESSIONID	none ▾	16
method	<input checked="" type="checkbox"/> none <input type="checkbox"/> Attribute <input type="checkbox"/> Pivot ID <input type="checkbox"/> Step	16
msg	none ▾	15
other	none ▾	15
product	none ▾	15
productid	none ▾	15
protocol	none ▾	15
q	none ▾	15

FIG. 37A

3700 →

splunk > App: Journey Analytics

Administrator

Messages Settings Activity Help

Find

Event Streams

Buttercup Games

Guest 360 Experience

Hotel Interactive Menu

In-room Chromecast Expe...

Order Process Flow

SFDC Oppty Stage Funnel

Sales Email

TV CHANNELS

+ Add New

3702

Edit: Buttercup Games

Search 3701A 3701B 3701C

Field Mapping Sessionization

3710A 3710A 3710C 3704

(Step) (Pivot IDs (1)) (Attributes (0))

Hide default fields

Preview values for action 3706

Value	Count
purchase	2905
addtocart	2860
view	2794
changequantity	745
remove	696

Field	Usage
action	none ▾
bytes	<div style="border: 1px solid black; padding: 2px;"> ✓ none 3708 Attribute Pivot ID Step </div>
category/Id	
clntip	
cookie	none ▾
detail	none ▾
file	none ▾
ident	none ▾
items	none ▾
JSESSIONID	Pivot ID ▾

Journey Analytics

Home

Settings

Settings

FIG. 37B

3800 →
3702
Journey Analytics

splunk> App: Journey Analytics
Administrator
Messages
Settings
Activity
Help
Find

Event Streams

- Buttercup Games
- Guest 360 Experience
- Hotel Interactive Menu
- In-room Chromecast Expe...
- Order Process Flow
- SFDC Oppty Stage Funnel
- Sales Email
- TV CHANNELS

Buttercup Games

Earliest Event: May 3, 2017 6:24:19 PM

Total Sessions 3804

6,154

Total Events 3806

33,207

Session Max Duration 3808A

1 hr

Session Time Out 3808B

1 hr

Session Length Distribution 3810

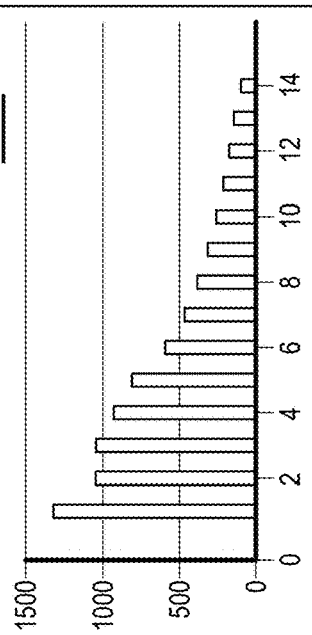

Last Modified: March 8, 2018 12:17:02 PM

Step	Count	Start %	End %
addtocart	6,285	34.27%	14.75%
changequality	1,542	8.04%	7.91%
purchase	6,481	1.09%	19.3%
remove	1,540	8.09%	7.83%
view	6,082	29.72%	31.41%

3814
3812

Explore >>

FIG. 38

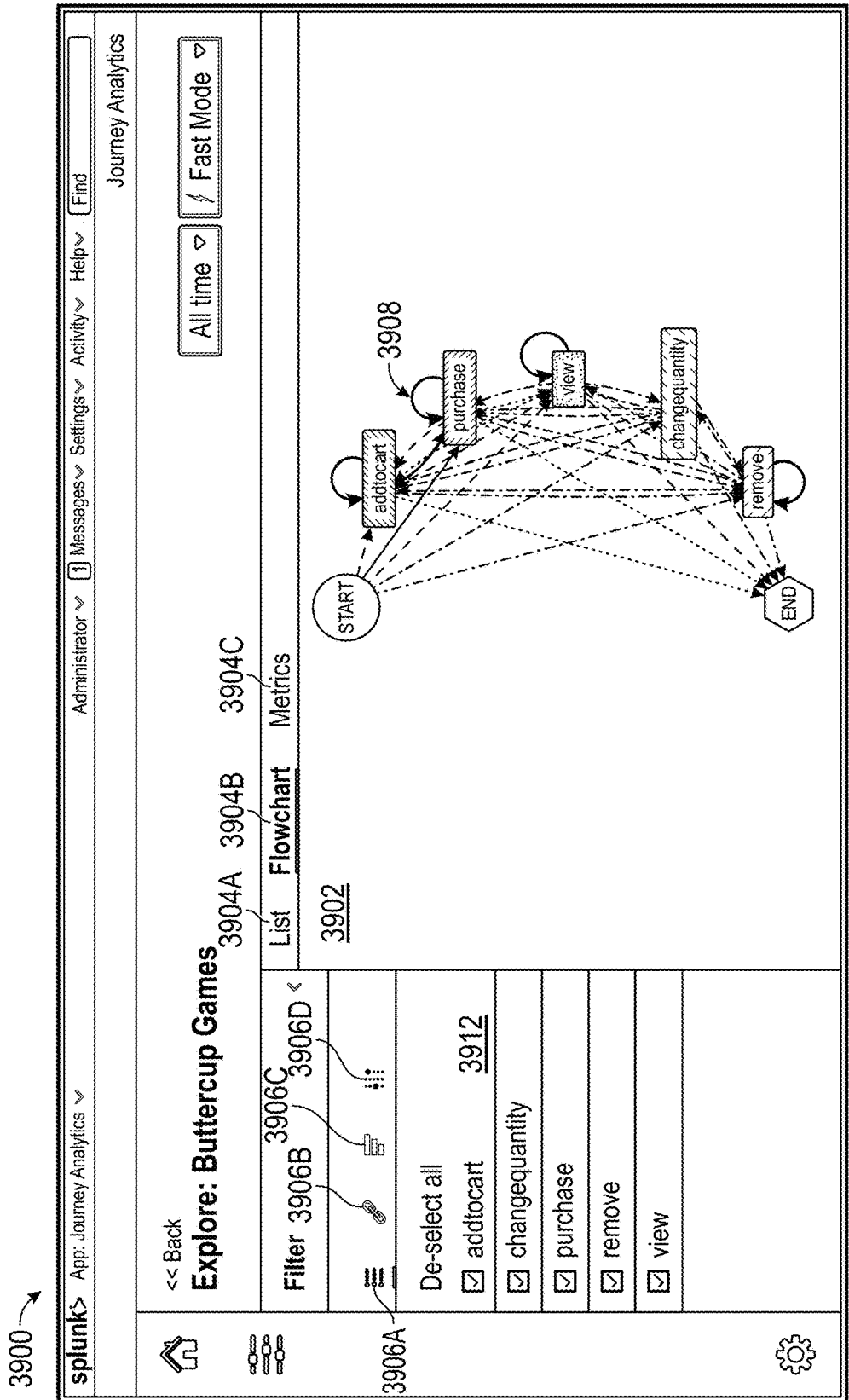

FIG. 39A

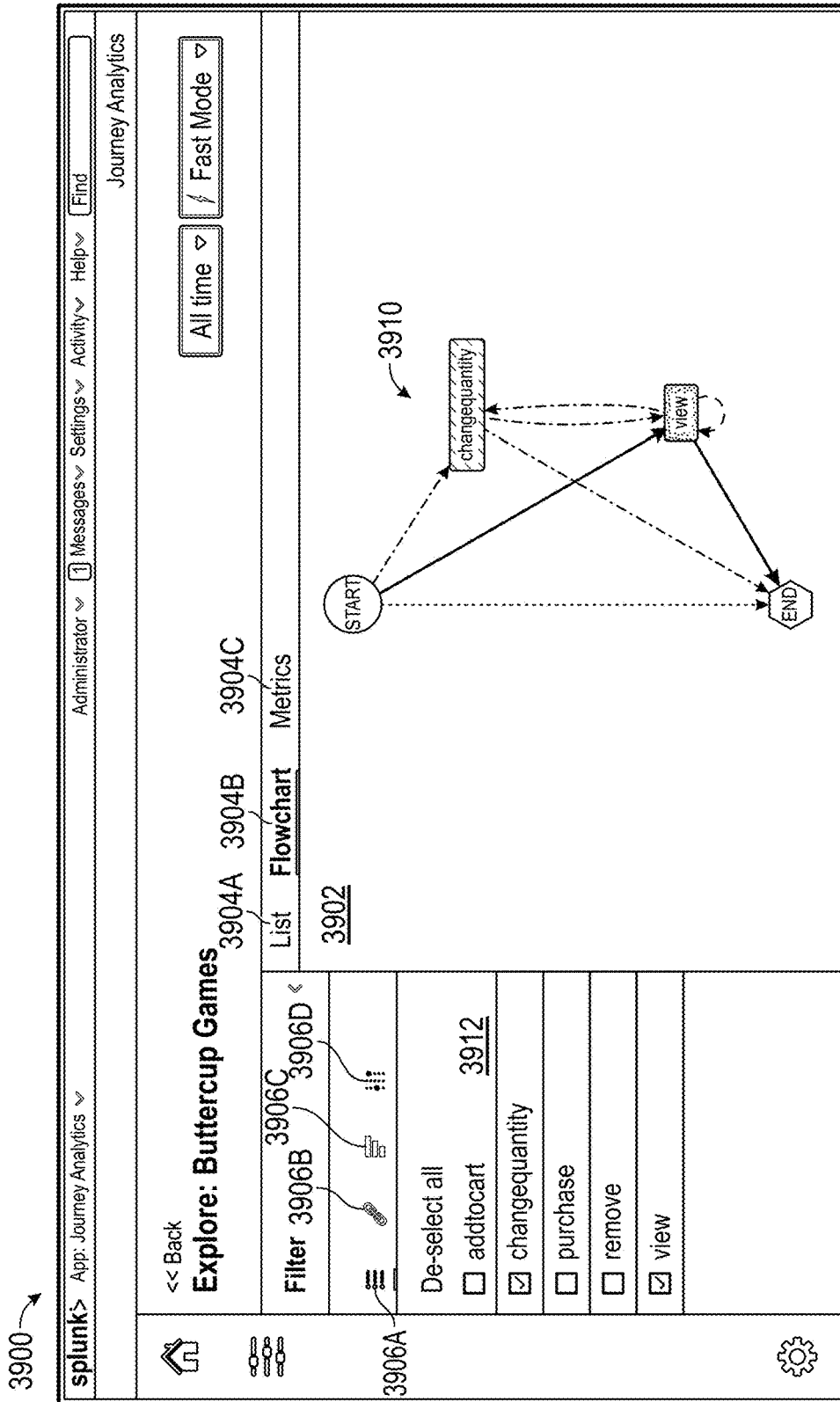

FIG. 39B

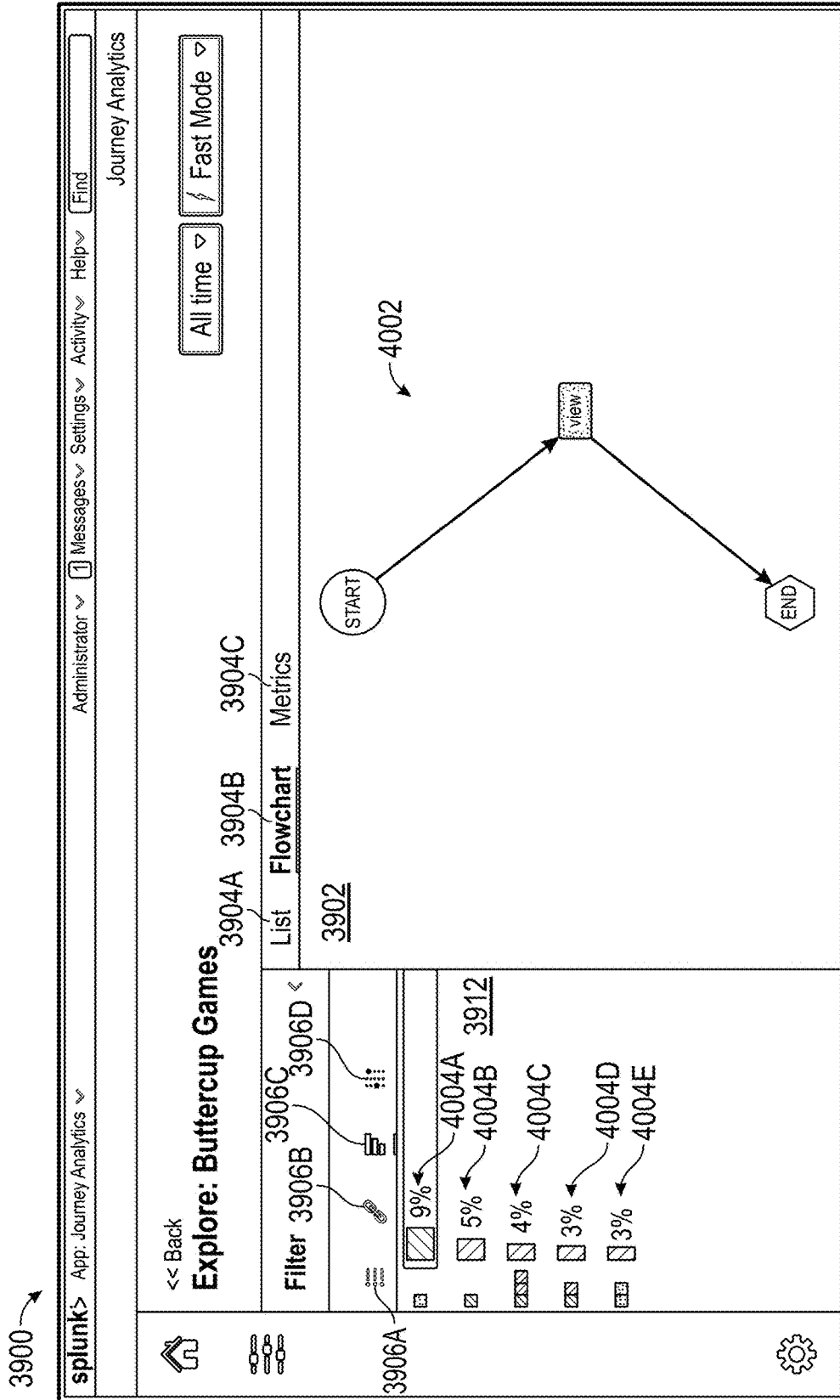

FIG. 40A

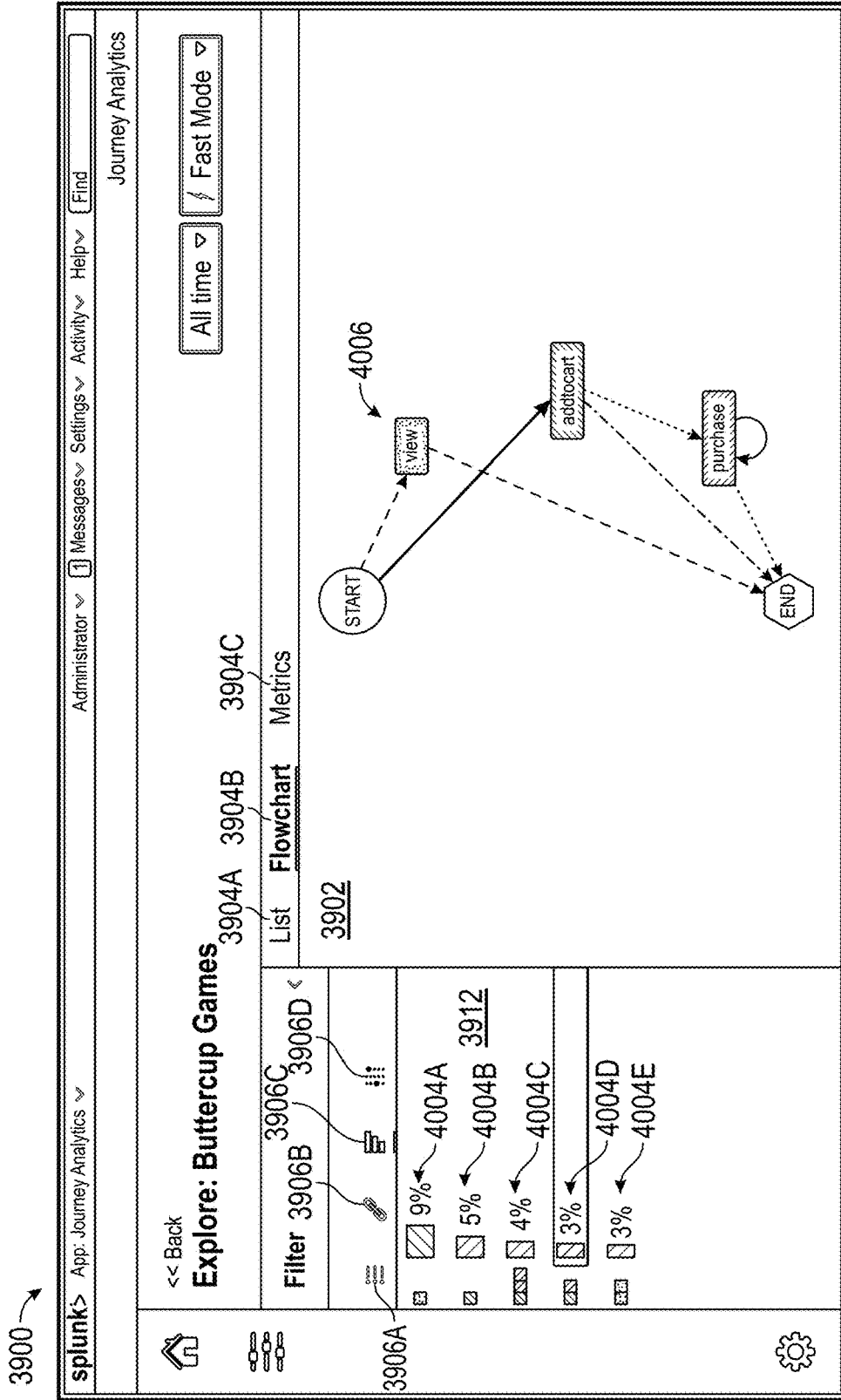

FIG. 40B

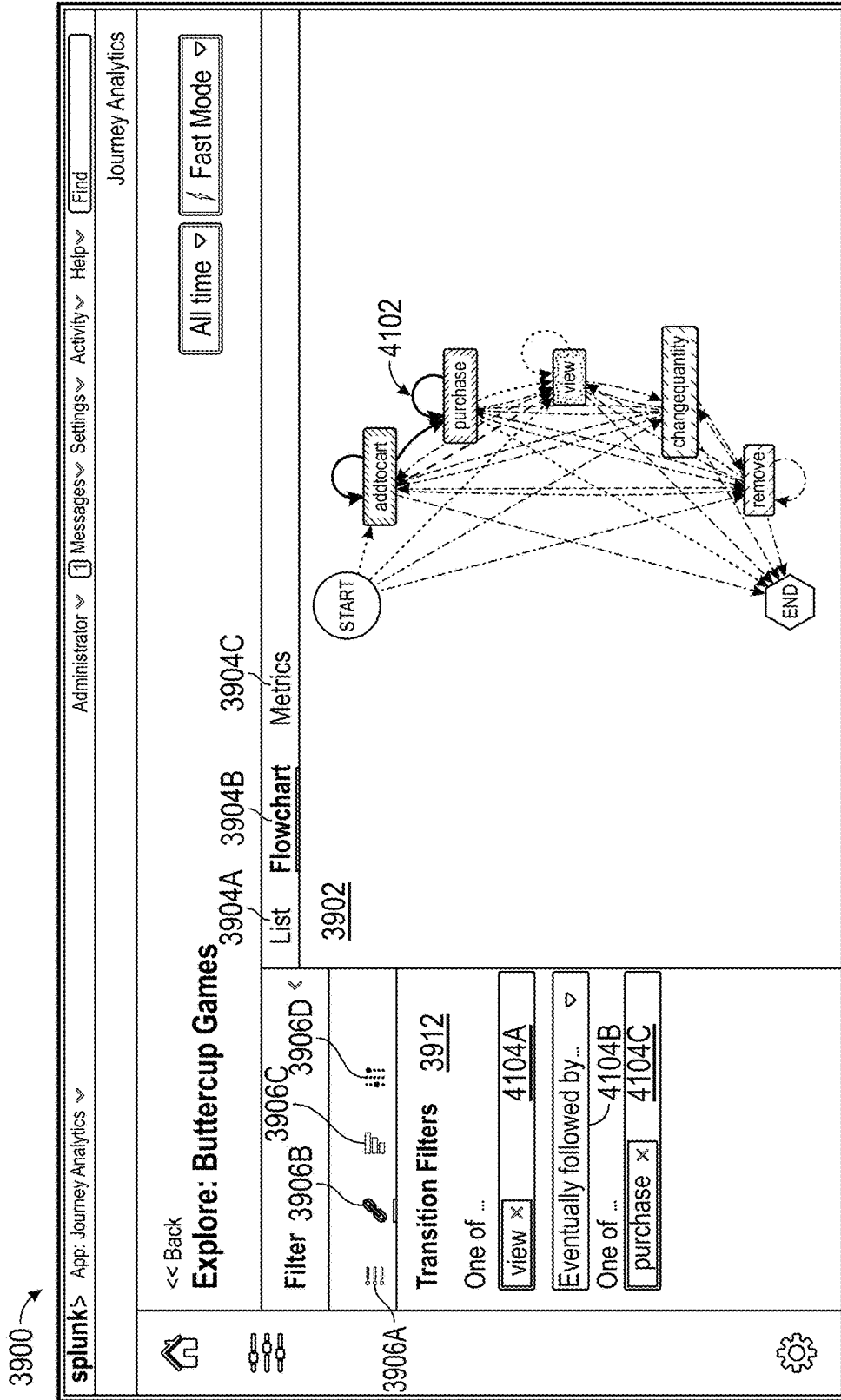

FIG. 41

3900 →

splunk> App: Journey Analytics ▾ Administrator ▾ 1 Messages ▾ Settings ▾ Activity ▾ Help ▾ Find

Journey Analytics

<< Back

Explore: Buttercup Games 3904A 3904B 3904C

Filter 3906B 3906C 3906D <

Transition Filters 3912

One of... 4104A

Eventually followed by... ▾

One of... 4104B

Select... 4104C

3906A

Fast Mode ▾

All time ▾

3902 < Prev 1 2 3 4 5 6 7 8 9 ... 10 Next > 4208 4210 4212

PIVOT ID (JSESSIONID)	Start Time	End Time	Total Duration	Event Count	Sequence
SD4SL6FF7ADFF4963 4214A	5/18/2017 11:59:17 PM	5/18/2017 11:59:17 PM	26 ms	3	3
SD1SL7FF6ADFF89341 4214B	5/18/2017 11:57:11 PM	5/18/2017 11:57:11 PM	4 ms	3	3
SD7SL2FF9ADFF89669 4214C	5/18/2017 11:56:46 PM	5/18/2017 11:56:46 PM	28 ms	2	2
SD3SL6FF3ADFF4952 4214D	5/18/2017 11:55:47 PM	5/18/2017 11:55:47 PM	0 ms	1	1
SD8SL8FF6ADFF4957 4214E	5/18/2017 11:51:52 PM	5/18/2017 11:51:52 PM	111 ms	5	5
SD2SL10FF6ADFF4955 4214F	5/18/2017 11:50:00 PM	5/18/2017 11:50:00 PM	48 ms	4	4
SD3SL5FF2ADFF4957 4214G	5/18/2017 11:45:16 PM	5/18/2017 11:45:16 PM	0 ms	1	1
SD5SL2FF7ADFF4951 4214H	5/18/2017	5/18/2017	101 ms	4	4

3900A

3902 4202 4204 4206 4208 4210 4212

List Flowchart Metrics

3906A

3906B 3906C 3906D

3904A 3904B 3904C

3900

FIG. 42

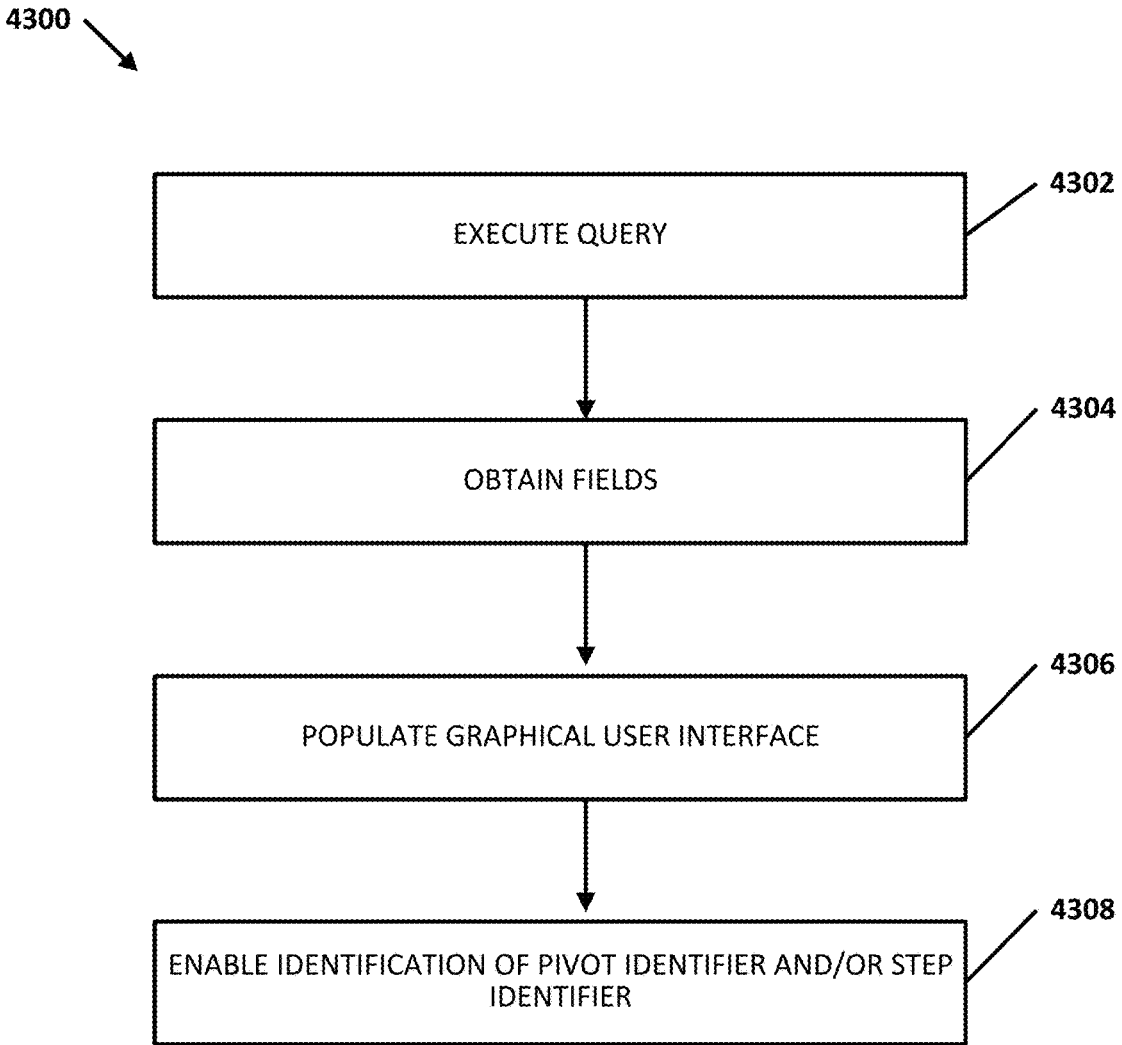

FIG. 43

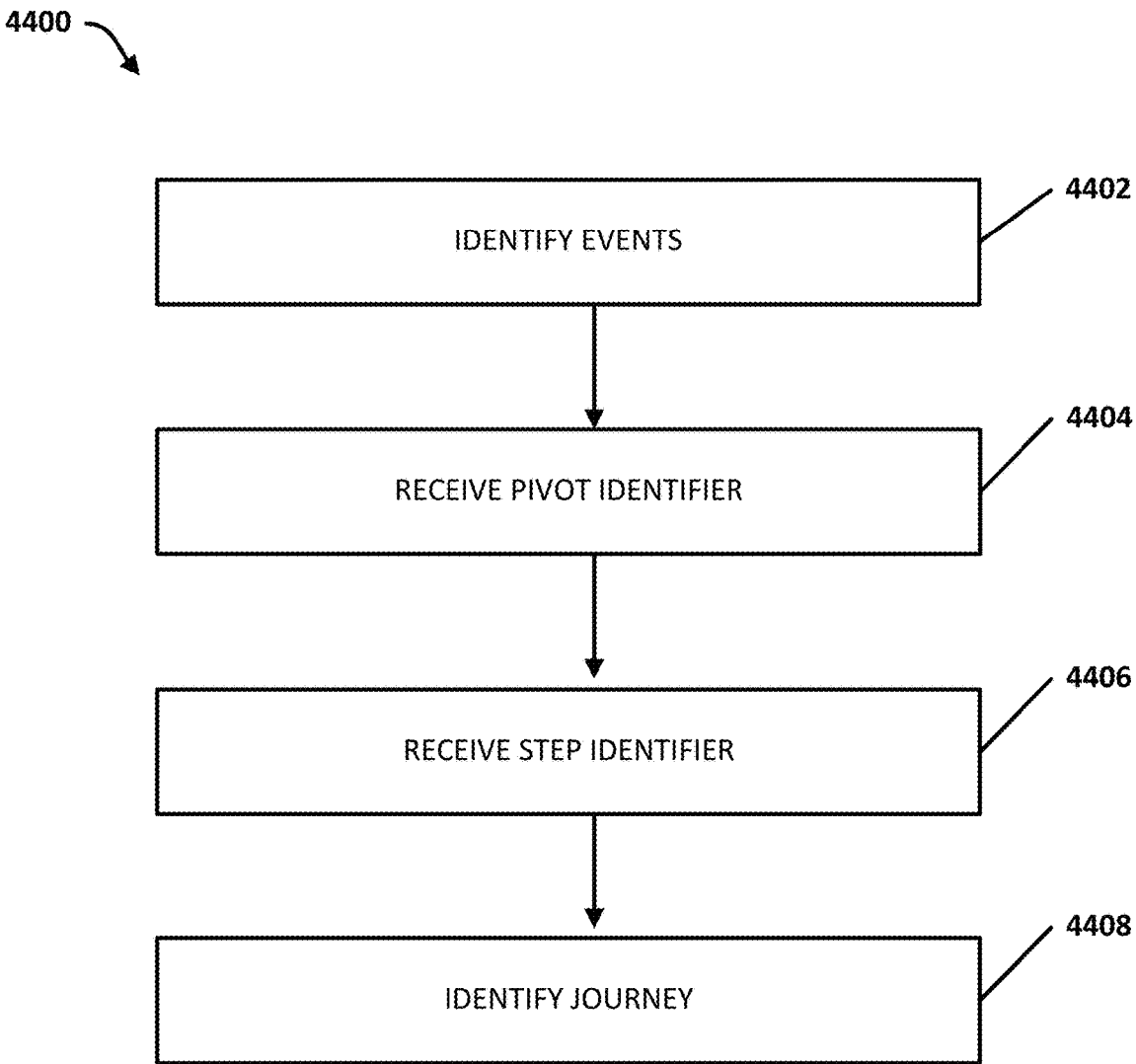

FIG. 44

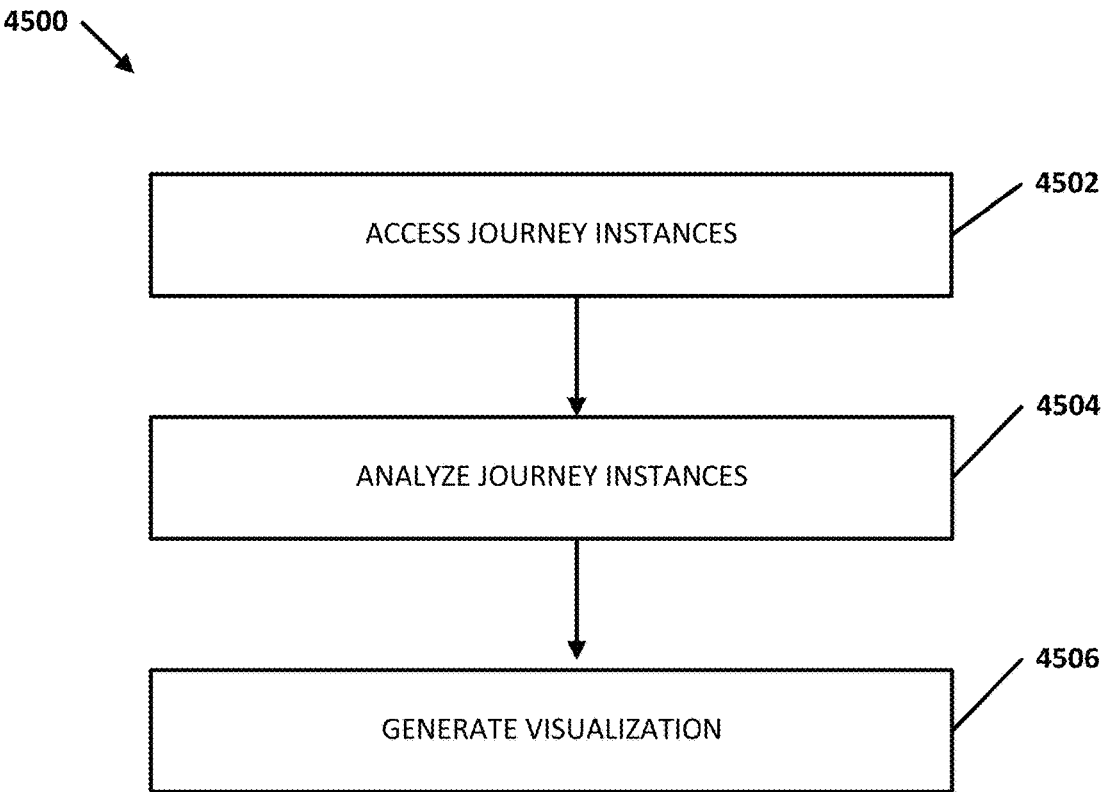

FIG. 45

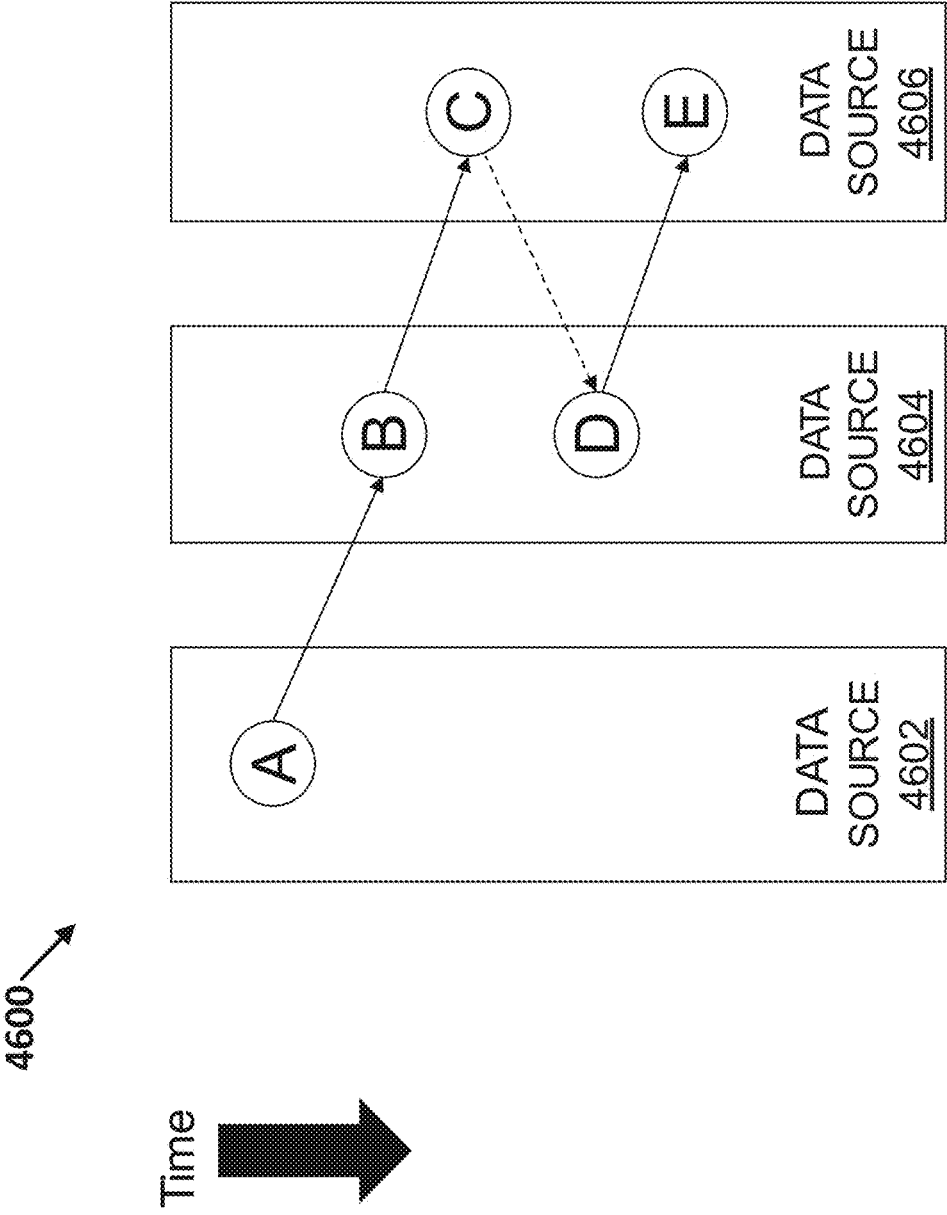

FIG. 46

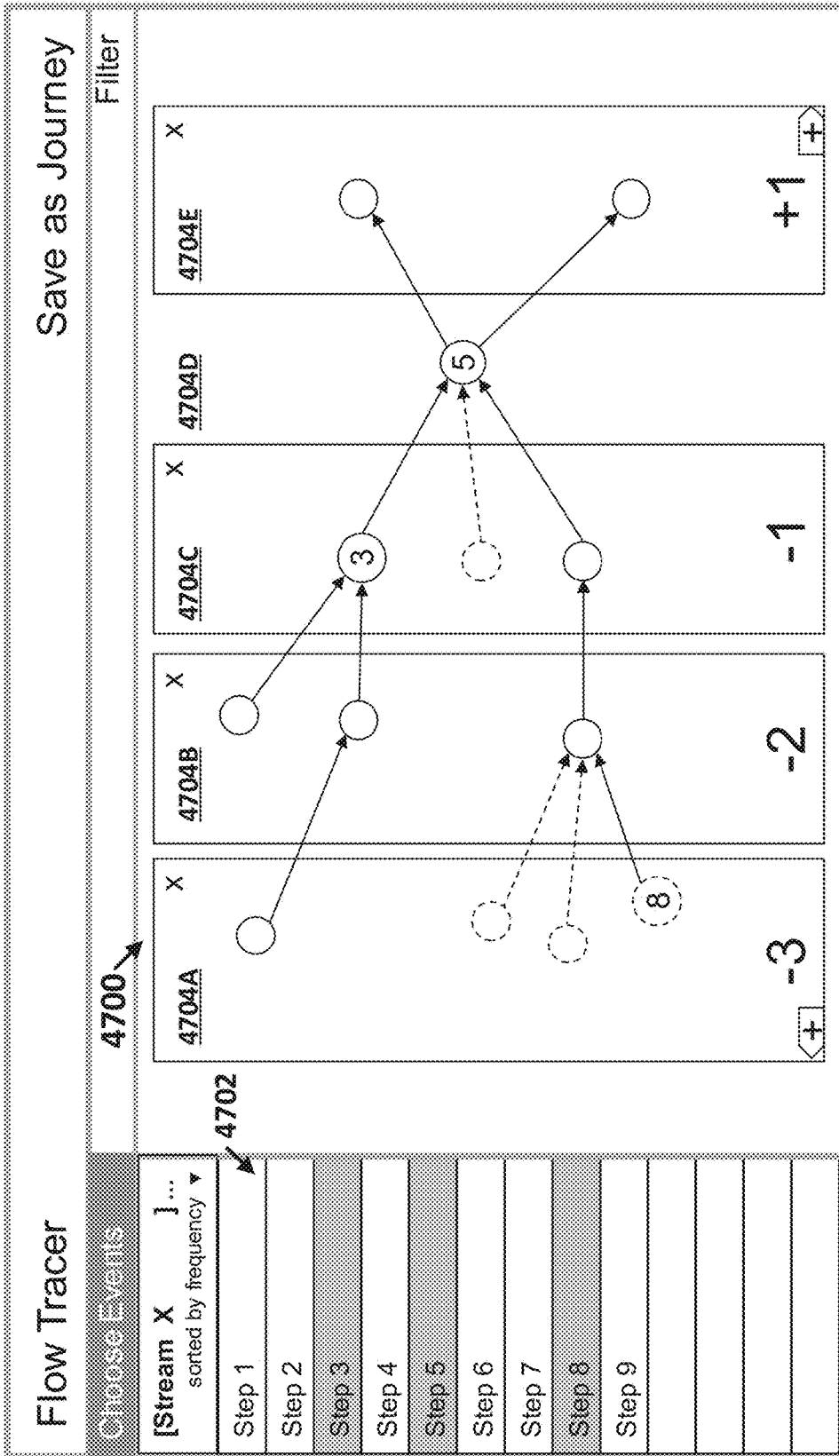

FIG. 47

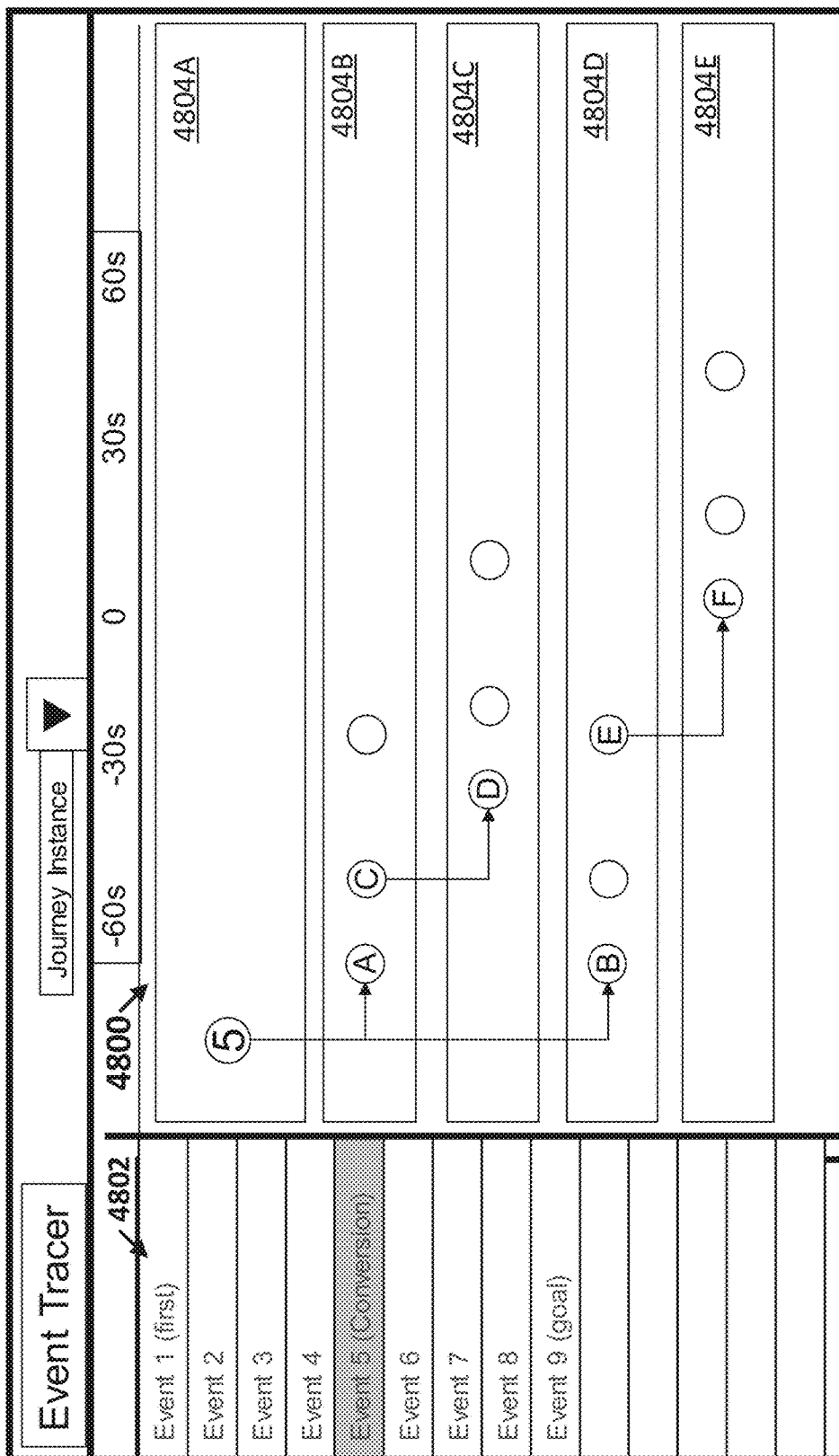

FIG. 48

**USER INTERFACE AND PROCESS TO
GENERATE JOURNEY INSTANCE BASED
ON ONE OR MORE PIVOT IDENTIFIERS
AND ONE OR MORE STEP IDENTIFIERS**

RELATED APPLICATIONS

[0001] This application filed on Mar. 26, 2018, is being filed concurrently with the following applications, each of which is incorporated by reference in its entirety.

Attorney Docket	Title	Filed On
SPLK.029A1	JOURNEY INSTANCE GENERATION BASED ON ONE OR MORE PIVOT IDENTIFIERS AND ONE OR MORE STEP IDENTIFIERS	Mar. 26, 2018
SPLK.029A2	USER INTERFACE TO IDENTIFY ONE OR MORE PIVOT IDENTIFIERS AND ONE OR MORE STEP IDENTIFIERS TO PROCESS EVENTS	Mar. 26, 2018
SPLK.029A4	ANALYZING JOURNEY INSTANCES THAT INCLUDE AN ORDERING OF STEP INSTANCES INCLUDING A SUBSET OF A SET OF EVENTS	Mar. 26, 2018

FIELD

[0002] At least one embodiment of the present disclosure pertains to one or more tools for facilitating searching and analyzing large sets of data to locate data of interest.

BACKGROUND

[0003] Information technology (IT) environments can include diverse types of data systems that store large amounts of diverse data types generated by numerous devices. For example, a big data ecosystem may include databases such as MySQL and Oracle databases, cloud computing services such as Amazon web services (AWS), and other data systems that store passively or actively generated data, including machine-generated data (“machine data”). The machine data can include performance data, diagnostic data, or any other data that can be analyzed to diagnose equipment performance problems, monitor user interactions, and to derive other insights.

[0004] The large amount and diversity of data systems containing large amounts of structured, semi-structured, and unstructured data relevant to any search query can be massive, and continues to grow rapidly. This technological evolution can give rise to various challenges in relation to managing, understanding and effectively utilizing the data. To reduce the potentially vast amount of data that may be generated, some data systems pre-process data based on anticipated data analysis needs. In particular, specified data items may be extracted from the generated data and stored in a data system to facilitate efficient retrieval and analysis of those data items at a later time. At least some of the remainder of the generated data is typically discarded during pre-processing.

[0005] However, storing massive quantities of minimally processed or unprocessed data (collectively and individually referred to as “raw data”) for later retrieval and analysis is becoming increasingly more feasible as storage capacity becomes more inexpensive and plentiful. In general, storing raw data and performing analysis on that data later can provide greater flexibility because it enables an analyst to analyze all of the generated data instead of only a fraction of it.

[0006] Although the availability of vastly greater amounts of diverse data on diverse data systems provides opportunities to derive new insights, it also gives rise to technical challenges to search and analyze the data. Tools exist that allow an analyst to search data systems separately and collect results over a network for the analyst to derive insights in a piecemeal manner. However, UI tools that allow analysts to quickly search and analyze large set of raw machine data to visually identify data subsets of interest,

particularly via straightforward and easy-to-understand sets of tools and search functionality do not exist.

BRIEF DESCRIPTION OF THE DRAWINGS

[0007] The present disclosure is illustrated by way of example, and not limitation, in the figures of the accompanying drawings, in which like reference numerals indicate similar elements and in which:

[0008] FIG. 1 is a block diagram of an example networked computer environment, in accordance with example embodiments;

[0009] FIG. 2 is a block diagram of an example data intake and query system, in accordance with example embodiments;

[0010] FIG. 3 is a block diagram of an example cloud-based data intake and query system, in accordance with example embodiments;

[0011] FIG. 4 is a block diagram of an example data intake and query system that performs searches across external data systems, in accordance with example embodiments;

[0012] FIG. 5A is a flowchart of an example method that illustrates how indexers process, index, and store data received from forwarders, in accordance with example embodiments;

[0013] FIG. 5B is a block diagram of a data structure in which time-stamped event data can be stored in a data store, in accordance with example embodiments;

[0014] FIG. 5C provides a visual representation of the manner in which a pipelined search language or query operates, in accordance with example embodiments;

[0015] FIG. 6A is a flow diagram of an example method that illustrates how a search head and indexers perform a search query, in accordance with example embodiments;

[0016] FIG. 6B provides a visual representation of an example manner in which a pipelined command language or query operates, in accordance with example embodiments;

[0017] FIG. 7A is a diagram of an example scenario where a common customer identifier is found among log data received from three disparate data sources, in accordance with example embodiments;

[0018] FIG. 7B illustrates an example of processing keyword searches and field searches, in accordance with disclosed embodiments;

[0019] FIG. 7C illustrates an example of creating and using an inverted index, in accordance with example embodiments;

[0020] FIG. 7D depicts a flowchart of example use of an inverted index in a pipelined search query, in accordance with example embodiments;

[0021] FIG. 8A is an interface diagram of an example user interface for a search screen, in accordance with example embodiments;

[0022] FIG. 8B is an interface diagram of an example user interface for a data summary dialog that enables a user to select various data sources, in accordance with example embodiments;

[0023] FIGS. 9-15 are interface diagrams of example report generation user interfaces, in accordance with example embodiments;

[0024] FIG. 16 is an example search query received from a client and executed by search peers, in accordance with example embodiments;

[0025] FIG. 17A is an interface diagram of an example user interface of a key indicators view, in accordance with example embodiments;

[0026] FIG. 17B is an interface diagram of an example user interface of an incident review dashboard, in accordance with example embodiments;

[0027] FIG. 17C is a tree diagram of an example proactive monitoring tree, in accordance with example embodiments;

[0028] FIG. 17D is an interface diagram of an example user interface displaying both log data and performance data, in accordance with example embodiments;

[0029] FIG. 18 illustrates an example user interface displaying a user journey;

[0030] FIG. 19 illustrates an example process for creating a user journey;

[0031] FIG. 20 illustrates an example user interface for mapping a field identifier in a particular data source;

[0032] FIG. 21 illustrates another example user interface for mapping a field identifier in a particular data source;

[0033] FIG. 22 illustrates an example user interface for specifying information that is to be recorded for a particular step;

[0034] FIG. 23 illustrates a user interface for selecting steps to be included in a user journey;

[0035] FIG. 24 illustrates an example user interface for specifying correlations between data sources selected for a user journey;

[0036] FIG. 25 is a user interface illustrating a first example stitching scheme;

[0037] FIG. 26 is a user interface illustrating a second example stitching scheme;

[0038] FIG. 27 is a user interface illustrating a third example stitching scheme;

[0039] FIG. 28 illustrates a representation of steps included in a user journey;

[0040] FIG. 29 is a flowchart of an example process for presenting results associated with a user journey;

[0041] FIG. 30 is a flowchart of another example process for presenting results associated with a user journey;

[0042] FIG. 31 illustrates an example user interface that includes a user journey and information indicating clusters associated with the user journey;

[0043] FIG. 32 illustrates an example user interface presenting summary information associated with a user journey;

[0044] FIG. 33 illustrates another example user interface presenting summary information associated with a user journey;

[0045] FIG. 34 illustrates an example user interface presenting a nested user journey included in a user journey;

[0046] FIG. 35 illustrates an example user interface indicating a path a particular entity took through steps included in a user journey;

[0047] FIG. 36 illustrates an example user interface presenting touchpoints associated with a particular entity;

[0048] FIGS. 37A and 37B illustrate an example user interface for identifying one or more pivot identifiers and one or more step identifiers;

[0049] FIG. 38 is a diagram illustrating an example user interface displaying an embodiment of a journey summarization;

[0050] FIGS. 39A, 39B, 40A, 40B, 41, and 42 are diagrams illustrating an example user interface displaying embodiments of journey summarizations;

[0051] FIG. 43 is a flow diagram illustrating an embodiment of a routine for enabling identification of one or more pivot identifiers and/or one or more step identifiers;

[0052] FIG. 44 is a flow diagram illustrating an embodiment of a routine for generating a journey instance or model;

[0053] FIG. 45 is a flow diagram illustrating an embodiment of a routine for analyzing journey instances; and

[0054] FIGS. 46, 47, and 48 are diagrams illustrating embodiments of journey visualizations.

I. DETAILED DESCRIPTION

[0055] Embodiments are described herein according to the following outline:

[0056] 1.0. General Overview

[0057] 2.0. Operating Environment

[0058] 2.1. Host Devices

[0059] 2.2. Client Devices

[0060] 2.3. Client Device Applications

[0061] 2.4. Data Server System

[0062] 2.5 Cloud-Based System Overview

[0063] 2.6 Searching Externally-Archived Data

[0064] 2.6.1. ERP Process Features

[0065] 2.7. Data Ingestion

[0066] 2.7.1. Input

[0067] 2.7.2. Parsing

[0068] 2.7.3. Indexing

[0069] 2.8. Query Processing

[0070] 2.9. Pipelined Search Language

[0071] 2.10. Field Extraction

- [0072] 2.11. Example Search Screen
- [0073] 2.12. Data Modeling
- [0074] 2.13. Acceleration Techniques
 - [0075] 2.13.1. Aggregation Technique
 - [0076] 2.13.2. Keyword Index
 - [0077] 2.13.3. High Performance Analytics Store
 - [0078] 2.13.3.1 Extracting Event Data Using Posting Values
 - [0079] 2.13.4. Accelerating Report Generation
- [0080] 2.14. Security Features
- [0081] 2.15. Data Center Monitoring
- [0082] 2.16. IT Service Monitoring
- [0083] 3.0 User Journeys
- [0084] 4.0 Journey Instances and Models
 - [0085] 4.1 User Interface Overview
 - [0086] 4.1.1 Displaying Field Identifiers
 - [0087] 4.1.2 Selecting Pivot Identifiers and Step Identifiers
 - [0088] 4.2 Pivot Identifiers
 - [0089] 4.2.1 Gluing Events
 - [0090] 4.3 Step Identifiers
 - [0091] 4.4 Attributes
 - [0092] 4.5 Journey Summarization Overview
 - [0093] 4.6 Journey Visualizations
 - [0094] 4.6.1 Control Selection
 - [0095] 4.6.2 Journey Model Visualization
 - [0096] 4.6.3 Clusters of Journey Instances
 - [0097] 4.6.4 Filtering Journey Instances
 - [0098] 4.6.5 List Display of Journey Instances
 - [0099] 4.7 Journey Instance and Model Flows
 - [0100] 4.8 Additional Journey Visualizations

[0101] In this description, references to “an embodiment,” “one embodiment,” or the like, mean that the particular feature, function, structure or characteristic being described is included in at least one embodiment of the technique introduced herein. Occurrences of such phrases in this specification do not necessarily all refer to the same embodiment. On the other hand, the embodiments referred to are also not necessarily mutually exclusive.

[0102] A data intake and query system can index and store data in data stores of indexers, and can receive search queries causing a search of the indexers to obtain search results. The data intake and query system typically has search, extraction, execution, and analytics capabilities that may be limited in scope to the data stores of the indexers (“internal data stores”). Hence, a seamless and comprehensive search and analysis that includes diverse data types from external data sources, common storage (may also be referred to as global data storage or global data stores), ingested data buffers, query acceleration data stores, etc. may be difficult. Thus, the capabilities of some data intake and query systems remain isolated from a variety of data sources that could improve search results to provide new insights. Furthermore, the processing flow of some data intake and query systems are unidirectional in that data is obtained from a data source, processed, and then communicated to a search head or client without the ability to route data to different destinations.

[0103] The disclosed embodiments overcome these drawbacks by extending the search and analytics capabilities of a data intake and query system to include diverse data types stored in diverse data systems internal to or external from the data intake and query system. As a result, an analyst can use the data intake and query system to search and analyze data

from a wide variety of dataset sources, including enterprise systems and open source technologies of a big data ecosystem. The term “big data” refers to large data sets that may be analyzed computationally to reveal patterns, trends, and associations, in some cases, relating to human behavior and interactions.

[0104] In particular, introduced herein is a data intake and query system that has the ability to execute big data analytics seamlessly and can scale across diverse data sources to enable processing large volumes of diverse data from diverse data systems. A “data source” can include a “data system,” which may refer to a system that can process and/or store data. A “data storage system” may refer to a storage system that can store data such as unstructured, semi-structured, or structured data. Accordingly, a data source can include a data system that includes a data storage system.

[0105] The system can improve search and analytics capabilities of previous systems by employing a search process master and query coordinators combined with a scalable network of distributed nodes communicatively coupled to diverse data systems. The network of distributed nodes can act as agents of the data intake and query system to collect and process data of distributed data systems, and the search process master and coordinators can provide the processed data to the search head as search results.

[0106] For example, the data intake and query system can respond to a query by executing search operations on various internal and external data sources to obtain partial search results that are harmonized and presented as search results of the query. As such, the data intake and query system can offload search and analytics operations to the distributed nodes. Hence, the system enables search and analytics capabilities that can extend beyond the data stored on indexers to include external data systems, common storage, query acceleration data stores, ingested data buffers, etc.

[0107] The system can provide big data open stack integration to act as a big data pipeline that extends the search and analytics capabilities of a system over numerous and diverse data sources. For example, the system can extend the data execution scope of the data intake and query system to include data residing in external data systems such as MySQL, PostgreSQL, and Oracle databases; NoSQL data stores like Cassandra, Mongo DB; cloud storage like Amazon S3 and Hadoop distributed file system (HDFS); common storage; ingested data buffers; etc. Thus, the system can execute search and analytics operations for all possible combinations of data types stored in various data sources.

[0108] The distributed processing of the system enables scalability to include any number of distributed data systems. As such, queries received by the data intake and query system can be propagated to the network of distributed nodes to extend the search and analytics capabilities of the data intake and query system over different data sources. In this context, the network of distributed nodes can act as an extension of the local data intake in query system’s data processing pipeline to facilitate scalable analytics across the diverse data systems. Accordingly, the system can extend and transform the data intake and query system to include data resources into a data fabric platform that can leverage computing assets from anywhere and access and execute on data regardless of type or origin.

[0109] The disclosed embodiments include services such as new search capabilities, visualization tools, and other services that are seamlessly integrated into the DFS system. For example, the disclosed techniques include new search services performed on internal data stores, external data stores, or a combination of both. The search operations can provide ordered or unordered search results, or search results derived from data of diverse data systems, which can be visualized to provide new and useful insights about the data contained in a big data ecosystem.

[0110] Various other features of the DFS system introduced here will become apparent from the description that follows. First, however, it is useful to consider an example of an environment and system in which the techniques can be employed, as will now be described.

1.0. General Overview

[0111] Modern data centers and other computing environments can comprise anywhere from a few host computer systems to thousands of systems configured to process data, service requests from remote clients, and perform numerous other computational tasks. During operation, various components within these computing environments often generate significant volumes of machine data. Machine data is any data produced by a machine or component in an information technology (IT) environment and that reflects activity in the IT environment. For example, machine data can be raw machine data that is generated by various components in IT environments, such as servers, sensors, routers, mobile devices, Internet of Things (IoT) devices, etc. Machine data can include system logs, network packet data, sensor data, application program data, error logs, stack traces, system performance data, etc. In general, machine data can also include performance data, diagnostic information, and many other types of data that can be analyzed to diagnose performance problems, monitor user interactions, and to derive other insights.

[0112] A number of tools are available to analyze machine data. In order to reduce the size of the potentially vast amount of machine data that may be generated, many of these tools typically pre-process the data based on anticipated data-analysis needs. For example, pre-specified data items may be extracted from the machine data and stored in a database to facilitate efficient retrieval and analysis of those data items at search time. However, the rest of the machine data typically is not saved and is discarded during pre-processing. As storage capacity becomes progressively cheaper and more plentiful, there are fewer incentives to discard these portions of machine data and many reasons to retain more of the data.

[0113] This plentiful storage capacity is presently making it feasible to store massive quantities of minimally processed machine data for later retrieval and analysis. In general, storing minimally processed machine data and performing analysis operations at search time can provide greater flexibility because it enables an analyst to search all of the machine data, instead of searching only a pre-specified set of data items. This may enable an analyst to investigate different aspects of the machine data that previously were unavailable for analysis.

[0114] However, analyzing and searching massive quantities of machine data presents a number of challenges. For example, a data center, servers, or network appliances may generate many different types and formats of machine data

(e.g., system logs, network packet data (e.g., wire data, etc.), sensor data, application program data, error logs, stack traces, system performance data, operating system data, virtualization data, etc.) from thousands of different components, which can collectively be very time-consuming to analyze. In another example, mobile devices may generate large amounts of information relating to data accesses, application performance, operating system performance, network performance, etc. There can be millions of mobile devices that report these types of information.

[0115] These challenges can be addressed by using an event-based data intake and query system, such as the SPLUNK® ENTERPRISE system developed by Splunk Inc. of San Francisco, Calif. The SPLUNK® ENTERPRISE system is the leading platform for providing real-time operational intelligence that enables organizations to collect, index, and search machine data from various websites, applications, servers, networks, and mobile devices that power their businesses. The data intake and query system is particularly useful for analyzing data which is commonly found in system log files, network data, and other data input sources. Although many of the techniques described herein are explained with reference to a data intake and query system similar to the SPLUNK® ENTERPRISE system, these techniques are also applicable to other types of data systems.

[0116] In the data intake and query system, machine data are collected and stored as “events”. An event comprises a portion of machine data and is associated with a specific point in time. The portion of machine data may reflect activity in an IT environment and may be produced by a component of that IT environment, where the events may be searched to provide insight into the IT environment, thereby improving the performance of components in the IT environment. Events may be derived from “time series data,” where the time series data comprises a sequence of data points (e.g., performance measurements from a computer system, etc.) that are associated with successive points in time. In general, each event has a portion of machine data that is associated with a timestamp that is derived from the portion of machine data in the event. A timestamp of an event may be determined through interpolation between temporally proximate events having known timestamps or may be determined based on other configurable rules for associating timestamps with events.

[0117] In some instances, machine data can have a pre-defined format, where data items with specific data formats are stored at predefined locations in the data. For example, the machine data may include data associated with fields in a database table. In other instances, machine data may not have a predefined format (e.g., may not be at fixed, predefined locations), but may have repeatable (e.g., non-random) patterns. This means that some machine data can comprise various data items of different data types that may be stored at different locations within the data. For example, when the data source is an operating system log, an event can include one or more lines from the operating system log containing machine data that includes different types of performance and diagnostic information associated with a specific point in time (e.g., a timestamp).

[0118] Examples of components which may generate machine data from which events can be derived include, but are not limited to, web servers, application servers, databases, firewalls, routers, operating systems, and software

applications that execute on computer systems, mobile devices, sensors, Internet of Things (IoT) devices, etc. The machine data generated by such data sources can include, for example and without limitation, server log files, activity log files, configuration files, messages, network packet data, performance measurements, sensor measurements, etc.

[0119] The data intake and query system uses a flexible schema to specify how to extract information from events. A flexible schema may be developed and redefined as needed. Note that a flexible schema may be applied to events “on the fly,” when it is needed (e.g., at search time, index time, ingestion time, etc.). When the schema is not applied to events until search time, the schema may be referred to as a “late-binding schema.”

[0120] During operation, the data intake and query system receives machine data from any type and number of sources (e.g., one or more system logs, streams of network packet data, sensor data, application program data, error logs, stack traces, system performance data, etc.). The system parses the machine data to produce events each having a portion of machine data associated with a timestamp. The system stores the events in a data store. The system enables users to run queries against the stored events to, for example, retrieve events that meet criteria specified in a query, such as criteria indicating certain keywords or having specific values in defined fields. As used herein, the term “field” refers to a location in the machine data of an event containing one or more values for a specific data item. A field may be referenced by a field name associated with the field. As will be described in more detail herein, a field is defined by an extraction rule (e.g., a regular expression) that derives one or more values or a sub-portion of text from the portion of machine data in each event to produce a value for the field for that event. The set of values produced are semantically-related (such as IP address), even though the machine data in each event may be in different formats (e.g., semantically-related values may be in different positions in the events derived from different sources).

[0121] As described above, the system stores the events in a data store. The events stored in the data store are field-searchable, where field-searchable herein refers to the ability to search the machine data (e.g., the raw machine data) of an event based on a field specified in search criteria. For example, a search having criteria that specifies a field name “UserID” may cause the system to field-search the machine data of events to identify events that have the field name “UserID.” In another example, a search having criteria that specifies a field name “UserID” with a corresponding field value “12345” may cause the system to field-search the machine data of events to identify events having that field-value pair (e.g., field name “UserID” with a corresponding field value of “12345”). Events are field-searchable using one or more configuration files associated with the events. Each configuration file includes one or more field names, where each field name is associated with a corresponding extraction rule and a set of events to which that extraction rule applies. The set of events to which an extraction rule applies may be identified by metadata associated with the set of events. For example, an extraction rule may apply to a set of events that are each associated with a particular host, source, or source type. When events are to be searched based on a particular field name specified in a search, the system uses one or more configuration files to determine whether there is an extraction rule for that particular field name that

applies to each event that falls within the criteria of the search. If so, the event is considered as part of the search results (and additional processing may be performed on that event based on criteria specified in the search). If not, the next event is similarly analyzed, and so on.

[0122] As noted above, the data intake and query system utilizes a late-binding schema while performing queries on events. One aspect of a late-binding schema is applying extraction rules to events to extract values for specific fields during search time. More specifically, the extraction rule for a field can include one or more instructions that specify how to extract a value for the field from an event. An extraction rule can generally include any type of instruction for extracting values from events. In some cases, an extraction rule comprises a regular expression, where a sequence of characters form a search pattern. An extraction rule comprising a regular expression is referred to herein as a regex rule. The system applies a regex rule to an event to extract values for a field associated with the regex rule, where the values are extracted by searching the event for the sequence of characters defined in the regex rule.

[0123] In the data intake and query system, a field extractor may be configured to automatically generate extraction rules for certain fields in the events when the events are being created, indexed, or stored, or possibly at a later time. Alternatively, a user may manually define extraction rules for fields using a variety of techniques. In contrast to a conventional schema for a database system, a late-binding schema is not defined at data ingestion time. Instead, the late-binding schema can be developed on an ongoing basis until the time a query is actually executed. This means that extraction rules for the fields specified in a query may be provided in the query itself, or may be located during execution of the query. Hence, as a user learns more about the data in the events, the user can continue to refine the late-binding schema by adding new fields, deleting fields, or modifying the field extraction rules for use the next time the schema is used by the system. Because the data intake and query system maintains the underlying machine data and uses a late-binding schema for searching the machine data, it enables a user to continue investigating and learn valuable insights about the machine data.

[0124] In some embodiments, a common field name may be used to reference two or more fields containing equivalent and/or similar data items, even though the fields may be associated with different types of events that possibly have different data formats and different extraction rules. By enabling a common field name to be used to identify equivalent and/or similar fields from different types of events generated by disparate data sources, the system facilitates use of a “common information model” (CIM) across the disparate data sources (further discussed with respect to FIG. 7A).

2.0. Operating Environment

[0125] FIG. 1 is a block diagram of an example networked computer environment 100, in accordance with example embodiments. Those skilled in the art would understand that FIG. 1 represents one example of a networked computer system and other embodiments may use different arrangements.

[0126] The networked computer system 100 comprises one or more computing devices. These one or more computing devices comprise any combination of hardware and

software configured to implement the various logical components described herein. For example, the one or more computing devices may include one or more memories that store instructions for implementing the various components described herein, one or more hardware processors configured to execute the instructions stored in the one or more memories, and various data repositories in the one or more memories for storing data structures utilized and manipulated by the various components.

[0127] In some embodiments, one or more client devices **102** are coupled to one or more host devices **106** and a data intake and query system **108** via one or more networks **104**. Networks **104** broadly represent one or more LANs, WANs, cellular networks (e.g., LTE, HSPA, 3G, and other cellular technologies), and/or networks using any of wired, wireless, terrestrial microwave, or satellite links, and may include the public Internet.

2.1. Host Devices

[0128] In the illustrated embodiment, a system **100** includes one or more host devices **106**. Host devices **106** may broadly include any number of computers, virtual machine instances, and/or data centers that are configured to host or execute one or more instances of host applications **114**. In general, a host device **106** may be involved, directly or indirectly, in processing requests received from client devices **102**. Each host device **106** may comprise, for example, one or more of a network device, a web server, an application server, a database server, etc. A collection of host devices **106** may be configured to implement a network-based service. For example, a provider of a network-based service may configure one or more host devices **106** and host applications **114** (e.g., one or more web servers, application servers, database servers, etc.) to collectively implement the network-based application.

[0129] In general, client devices **102** communicate with one or more host applications **114** to exchange information. The communication between a client device **102** and a host application **114** may, for example, be based on the Hypertext Transfer Protocol (HTTP) or any other network protocol. Content delivered from the host application **114** to a client device **102** may include, for example, HTML documents, media content, etc. The communication between a client device **102** and host application **114** may include sending various requests and receiving data packets. For example, in general, a client device **102** or application running on a client device may initiate communication with a host application **114** by making a request for a specific resource (e.g., based on an HTTP request), and the application server may respond with the requested content stored in one or more response packets.

[0130] In the illustrated embodiment, one or more of host applications **114** may generate various types of performance data during operation, including event logs, network data, sensor data, and other types of machine data. For example, a host application **114** comprising a web server may generate one or more web server logs in which details of interactions between the web server and any number of client devices **102** is recorded. As another example, a host device **106** comprising a router may generate one or more router logs that record information related to network traffic managed by the router. As yet another example, a host application **114** comprising a database server may generate one or more logs that record information related to requests sent from other

host applications **114** (e.g., web servers or application servers) for data managed by the database server.

2.2. Client Devices

[0131] Client devices **102** of FIG. 1 represent any computing device capable of interacting with one or more host devices **106** via a network **104**. Examples of client devices **102** may include, without limitation, smart phones, tablet computers, handheld computers, wearable devices, laptop computers, desktop computers, servers, portable media players, gaming devices, and so forth. In general, a client device **102** can provide access to different content, for instance, content provided by one or more host devices **106**, etc. Each client device **102** may comprise one or more client applications **110**, described in more detail in a separate section hereinafter.

2.3. Client Device Applications

[0132] In some embodiments, each client device **102** may host or execute one or more client applications **110** that are capable of interacting with one or more host devices **106** via one or more networks **104**. For instance, a client application **110** may be or comprise a web browser that a user may use to navigate to one or more websites or other resources provided by one or more host devices **106**. As another example, a client application **110** may comprise a mobile application or “app.” For example, an operator of a network-based service hosted by one or more host devices **106** may make available one or more mobile apps that enable users of client devices **102** to access various resources of the network-based service. As yet another example, client applications **110** may include background processes that perform various operations without direct interaction from a user. A client application **110** may include a “plug-in” or “extension” to another application, such as a web browser plug-in or extension.

[0133] In some embodiments, a client application **110** may include a monitoring component **112**. At a high level, the monitoring component **112** comprises a software component or other logic that facilitates generating performance data related to a client device’s operating state, including monitoring network traffic sent and received from the client device and collecting other device and/or application-specific information. Monitoring component **112** may be an integrated component of a client application **110**, a plug-in, an extension, or any other type of add-on component. Monitoring component **112** may also be a stand-alone process.

[0134] In some embodiments, a monitoring component **112** may be created when a client application **110** is developed, for example, by an application developer using a software development kit (SDK). The SDK may include custom monitoring code that can be incorporated into the code implementing a client application **110**. When the code is converted to an executable application, the custom code implementing the monitoring functionality can become part of the application itself.

[0135] In some embodiments, an SDK or other code for implementing the monitoring functionality may be offered by a provider of a data intake and query system, such as a system **108**. In such cases, the provider of the system **108** can implement the custom code so that performance data generated by the monitoring functionality is sent to the

system **108** to facilitate analysis of the performance data by a developer of the client application or other users.

[0136] In some embodiments, the custom monitoring code may be incorporated into the code of a client application **110** in a number of different ways, such as the insertion of one or more lines in the client application code that call or otherwise invoke the monitoring component **112**. As such, a developer of a client application **110** can add one or more lines of code into the client application **110** to trigger the monitoring component **112** at desired points during execution of the application. Code that triggers the monitoring component may be referred to as a monitor trigger. For instance, a monitor trigger may be included at or near the beginning of the executable code of the client application **110** such that the monitoring component **112** is initiated or triggered as the application is launched, or included at other points in the code that correspond to various actions of the client application, such as sending a network request or displaying a particular interface.

[0137] In some embodiments, the monitoring component **112** may monitor one or more aspects of network traffic sent and/or received by a client application **110**. For example, the monitoring component **112** may be configured to monitor data packets transmitted to and/or from one or more host applications **114**. Incoming and/or outgoing data packets can be read or examined to identify network data contained within the packets, for example, and other aspects of data packets can be analyzed to determine a number of network performance statistics. Monitoring network traffic may enable information to be gathered particular to the network performance associated with a client application **110** or set of applications.

[0138] In some embodiments, network performance data refers to any type of data that indicates information about the network and/or network performance. Network performance data may include, for instance, a URL requested, a connection type (e.g., HTTP, HTTPS, etc.), a connection start time, a connection end time, an HTTP status code, request length, response length, request headers, response headers, connection status (e.g., completion, response time(s), failure, etc.), and the like. Upon obtaining network performance data indicating performance of the network, the network performance data can be transmitted to a data intake and query system **108** for analysis.

[0139] Upon developing a client application **110** that incorporates a monitoring component **112**, the client application **110** can be distributed to client devices **102**. Applications generally can be distributed to client devices **102** in any manner, or they can be pre-loaded. In some cases, the application may be distributed to a client device **102** via an application marketplace or other application distribution system. For instance, an application marketplace or other application distribution system might distribute the application to a client device based on a request from the client device to download the application.

[0140] Examples of functionality that enables monitoring performance of a client device are described in U.S. patent application Ser. No. 14/524,748, entitled "UTILIZING PACKET HEADERS TO MONITOR NETWORK TRAFFIC IN ASSOCIATION WITH A CLIENT DEVICE", filed on 27 Oct. 2014, and which is hereby incorporated by reference in its entirety for all purposes.

[0141] In some embodiments, the monitoring component **112** may also monitor and collect performance data related

to one or more aspects of the operational state of a client application **110** and/or client device **102**. For example, a monitoring component **112** may be configured to collect device performance information by monitoring one or more client device operations, or by making calls to an operating system and/or one or more other applications executing on a client device **102** for performance information. Device performance information may include, for instance, a current wireless signal strength of the device, a current connection type and network carrier, current memory performance information, a geographic location of the device, a device orientation, and any other information related to the operational state of the client device.

[0142] In some embodiments, the monitoring component **112** may also monitor and collect other device profile information including, for example, a type of client device, a manufacturer and model of the device, versions of various software applications installed on the device, and so forth.

[0143] In general, a monitoring component **112** may be configured to generate performance data in response to a monitor trigger in the code of a client application **110** or other triggering application event, as described above, and to store the performance data in one or more data records. Each data record, for example, may include a collection of field-value pairs, each field-value pair storing a particular item of performance data in association with a field for the item. For example, a data record generated by a monitoring component **112** may include a "networkLatency" field (not shown in the Figure) in which a value is stored. This field indicates a network latency measurement associated with one or more network requests. The data record may include a "state" field to store a value indicating a state of a network connection, and so forth for any number of aspects of collected performance data.

2.4. Data Server System

[0144] FIG. 2 is a block diagram of an example data intake and query system **108**, in accordance with example embodiments. System **108** includes one or more forwarders **204** that receive data from a variety of input data sources **202**, and one or more indexers **206** that process and store the data in one or more data stores **208**. These forwarders **204** and indexers **208** can comprise separate computer systems, or may alternatively comprise separate processes executing on one or more computer systems.

[0145] Each data source **202** broadly represents a distinct source of data that can be consumed by system **108**. Examples of a data sources **202** include, without limitation, data files, directories of files, data sent over a network, event logs, registries, etc.

[0146] During operation, the forwarders **204** identify which indexers **206** receive data collected from a data source **202** and forward the data to the appropriate indexers. Forwarders **204** can also perform operations on the data before forwarding, including removing extraneous data, detecting timestamps in the data, parsing data, indexing data, routing data based on criteria relating to the data being routed, and/or performing other data transformations.

[0147] In some embodiments, a forwarder **204** may comprise a service accessible to client devices **102** and host devices **106** via a network **104**. For example, one type of forwarder **204** may be capable of consuming vast amounts of real-time data from a potentially large number of client devices **102** and/or host devices **106**. The forwarder **204**

may, for example, comprise a computing device which implements multiple data pipelines or “queues” to handle forwarding of network data to indexers 206. A forwarder 204 may also perform many of the functions that are performed by an indexer. For example, a forwarder 204 may perform keyword extractions on raw data or parse raw data to create events. A forwarder 204 may generate time stamps for events. Additionally or alternatively, a forwarder 204 may perform routing of events to indexers 206. Data store 208 may contain events derived from machine data from a variety of sources all pertaining to the same component in an IT environment, and this data may be produced by the machine in question or by other components in the IT environment.

2.5. Cloud-Based System Overview

[0148] The example data intake and query system 108 described in reference to FIG. 2 comprises several system components, including one or more forwarders, indexers, and search heads. In some environments, a user of a data intake and query system 108 may install and configure, on computing devices owned and operated by the user, one or more software applications that implement some or all of these system components. For example, a user may install a software application on server computers owned by the user and configure each server to operate as one or more of a forwarder, an indexer, a search head, etc. This arrangement generally may be referred to as an “on-premises” solution. That is, the system 108 is installed and operates on computing devices directly controlled by the user of the system. Some users may prefer an on-premises solution because it may provide a greater level of control over the configuration of certain aspects of the system (e.g., security, privacy, standards, controls, etc.). However, other users may instead prefer an arrangement in which the user is not directly responsible for providing and managing the computing devices upon which various components of system 108 operate.

[0149] In one embodiment, to provide an alternative to an entirely on-premises environment for system 108, one or more of the components of a data intake and query system instead may be provided as a cloud-based service. In this context, a cloud-based service refers to a service hosted by one more computing resources that are accessible to end users over a network, for example, by using a web browser or other application on a client device to interface with the remote computing resources. For example, a service provider may provide a cloud-based data intake and query system by managing computing resources configured to implement various aspects of the system (e.g., forwarders, indexers, search heads, etc.) and by providing access to the system to end users via a network. Typically, a user may pay a subscription or other fee to use such a service. Each subscribing user of the cloud-based service may be provided with an account that enables the user to configure a customized cloud-based system based on the user’s preferences.

[0150] FIG. 3 illustrates a block diagram of an example cloud-based data intake and query system. Similar to the system of FIG. 2, the networked computer system 300 includes input data sources 202 and forwarders 204. These input data sources and forwarders may be in a subscriber’s private computing environment. Alternatively, they might be directly managed by the service provider as part of the cloud service. In the example system 300, one or more forwarders

204 and client devices 302 are coupled to a cloud-based data intake and query system 306 via one or more networks 304. Network 304 broadly represents one or more LANs, WANs, cellular networks, intranetworks, internetworks, etc., using any of wired, wireless, terrestrial microwave, satellite links, etc., and may include the public Internet, and is used by client devices 302 and forwarders 204 to access the system 306. Similar to the system of 38, each of the forwarders 204 may be configured to receive data from an input source and to forward the data to other components of the system 306 for further processing.

[0151] In some embodiments, a cloud-based data intake and query system 306 may comprise a plurality of system instances 308. In general, each system instance 308 may include one or more computing resources managed by a provider of the cloud-based system 306 made available to a particular subscriber. The computing resources comprising a system instance 308 may, for example, include one or more servers or other devices configured to implement one or more forwarders, indexers, search heads, and other components of a data intake and query system, similar to system 108. As indicated above, a subscriber may use a web browser or other application of a client device 302 to access a web portal or other interface that enables the subscriber to configure an instance 308.

[0152] Providing a data intake and query system as described in reference to system 108 as a cloud-based service presents a number of challenges. Each of the components of a system 108 (e.g., forwarders, indexers, and search heads) may at times refer to various configuration files stored locally at each component. These configuration files typically may involve some level of user configuration to accommodate particular types of data a user desires to analyze and to account for other user preferences. However, in a cloud-based service context, users typically may not have direct access to the underlying computing resources implementing the various system components (e.g., the computing resources comprising each system instance 308) and may desire to make such configurations indirectly, for example, using one or more web-based interfaces. Thus, the techniques and systems described herein for providing user interfaces that enable a user to configure source type definitions are applicable to both on-premises and cloud-based service contexts, or some combination thereof (e.g., a hybrid system where both an on-premises environment, such as SPLUNK® ENTERPRISE, and a cloud-based environment, such as SPLUNK CLOUD™, are centrally visible).

2.6. Searching Externally-Archived Data

[0153] FIG. 4 shows a block diagram of an example of a data intake and query system 108 that provides transparent search facilities for data systems that are external to the data intake and query system. Such facilities are available in the Splunk® Analytics for Hadoop® system provided by Splunk Inc. of San Francisco, Calif. Splunk® Analytics for Hadoop® represents an analytics platform that enables business and IT teams to rapidly explore, analyze, and visualize data in Hadoop® and NoSQL data stores.

[0154] The search head 210 of the data intake and query system receives search requests from one or more client devices 404 over network connections 420. As discussed above, the data intake and query system 108 may reside in an enterprise location, in the cloud, etc. FIG. 4 illustrates that multiple client devices 404a, 404b, . . . , 404n may com-

municate with the data intake and query system 108. The client devices 404 may communicate with the data intake and query system using a variety of connections. For example, one client device in FIG. 4 is illustrated as communicating over an Internet (Web) protocol, another client device is illustrated as communicating via a command line interface, and another client device is illustrated as communicating via a software developer kit (SDK).

[0155] The search head 210 analyzes the received search request to identify request parameters. If a search request received from one of the client devices 404 references an index maintained by the data intake and query system, then the search head 210 connects to one or more indexers 206 of the data intake and query system for the index referenced in the request parameters. That is, if the request parameters of the search request reference an index, then the search head accesses the data in the index via the indexer. The data intake and query system 108 may include one or more indexers 206, depending on system access resources and requirements. As described further below, the indexers 206 retrieve data from their respective local data stores 208 as specified in the search request. The indexers and their respective data stores can comprise one or more storage devices and typically reside on the same system, though they may be connected via a local network connection.

[0156] If the request parameters of the received search request reference an external data collection, which is not accessible to the indexers 206 or under the management of the data intake and query system, then the search head 210 can access the external data collection through an External Result Provider (ERP) process 410. An external data collection may be referred to as a “virtual index” (plural, “virtual indices”). An ERP process provides an interface through which the search head 210 may access virtual indices.

[0157] Thus, a search reference to an index of the system relates to a locally stored and managed data collection. In contrast, a search reference to a virtual index relates to an externally stored and managed data collection, which the search head may access through one or more ERP processes 410, 412. FIG. 4 shows two ERP processes 410, 412 that connect to respective remote (external) virtual indices, which are indicated as a Hadoop or another system 414 (e.g., Amazon S3, Amazon EMR, other Hadoop® Compatible File Systems (HCFS), etc.) and a relational database management system (RDBMS) 416. Other virtual indices may include other file organizations and protocols, such as Structured Query Language (SQL) and the like. The ellipses between the ERP processes 410, 412 indicate optional additional ERP processes of the data intake and query system 108. An ERP process may be a computer process that is initiated or spawned by the search head 210 and is executed by the search data intake and query system 108. Alternatively or additionally, an ERP process may be a process spawned by the search head 210 on the same or different host system as the search head 210 resides.

[0158] The search head 210 may spawn a single ERP process in response to multiple virtual indices referenced in a search request, or the search head may spawn different ERP processes for different virtual indices. Generally, virtual indices that share common data configurations or protocols may share ERP processes. For example, all search query references to a Hadoop file system may be processed by the same ERP process, if the ERP process is suitably configured.

Likewise, all search query references to a SQL database may be processed by the same ERP process. In addition, the search head may provide a common ERP process for common external data source types (e.g., a common vendor may utilize a common ERP process, even if the vendor includes different data storage system types, such as Hadoop and SQL). Common indexing schemes also may be handled by common ERP processes, such as flat text files or Weblog files.

[0159] The search head 210 determines the number of ERP processes to be initiated via the use of configuration parameters that are included in a search request message. Generally, there is a one-to-many relationship between an external results provider “family” and ERP processes. There is also a one-to-many relationship between an ERP process and corresponding virtual indices that are referred to in a search request. For example, using RDBMS, assume two independent instances of such a system by one vendor, such as one RDBMS for production and another RDBMS used for development. In such a situation, it is likely preferable (but optional) to use two ERP processes to maintain the independent operation as between production and development data. Both of the ERPs, however, will belong to the same family, because the two RDBMS system types are from the same vendor.

[0160] The ERP processes 410, 412 receive a search request from the search head 210. The search head may optimize the received search request for execution at the respective external virtual index. Alternatively, the ERP process may receive a search request as a result of analysis performed by the search head or by a different system process. The ERP processes 410, 412 can communicate with the search head 210 via conventional input/output routines (e.g., standard in/standard out, etc.). In this way, the ERP process receives the search request from a client device such that the search request may be efficiently executed at the corresponding external virtual index.

[0161] The ERP processes 410, 412 may be implemented as a process of the data intake and query system. Each ERP process may be provided by the data intake and query system, or may be provided by process or application providers who are independent of the data intake and query system. Each respective ERP process may include an interface application installed at a computer of the external result provider that ensures proper communication between the search support system and the external result provider. The ERP processes 410, 412 generate appropriate search requests in the protocol and syntax of the respective virtual indices 414, 416, each of which corresponds to the search request received by the search head 210. Upon receiving search results from their corresponding virtual indices, the respective ERP process passes the result to the search head 210, which may return or display the results or a processed set of results based on the returned results to the respective client device.

[0162] Client devices 404 may communicate with the data intake and query system 108 through a network interface 420, e.g., one or more LANs, WANs, cellular networks, intranetworks, and/or internetworks using any of wired, wireless, terrestrial microwave, satellite links, etc., and may include the public Internet.

[0163] The analytics platform utilizing the External Result Provider process described in more detail in U.S. Pat. No. 8,738,629, entitled “EXTERNAL RESULT PROVIDED

PROCESS FOR RETRIEVING DATA STORED USING A DIFFERENT CONFIGURATION OR PROTOCOL”, issued on 27 May 2014, U.S. Pat. No. 8,738,587, entitled “PROCESSING A SYSTEM SEARCH REQUEST BY RETRIEVING RESULTS FROM BOTH A NATIVE INDEX AND A VIRTUAL INDEX”, issued on 25 Jul. 2013, U.S. patent application Ser. No. 14/266,832, entitled “PROCESSING A SYSTEM SEARCH REQUEST ACROSS DISPARATE DATA COLLECTION SYSTEMS”, filed on 1 May 2014, and U.S. Pat. No. 9,514,189, entitled “PROCESSING A SYSTEM SEARCH REQUEST INCLUDING EXTERNAL DATA SOURCES”, issued on 6 Dec. 2016, each of which is hereby incorporated by reference in its entirety for all purposes.

2.6.1. ERP Process Features

[0164] The ERP processes described above may include two operation modes: a streaming mode and a reporting mode. The ERP processes can operate in streaming mode only, in reporting mode only, or in both modes simultaneously. Operating in both modes simultaneously is referred to as mixed mode operation. In a mixed mode operation, the ERP at some point can stop providing the search head with streaming results and only provide reporting results thereafter, or the search head at some point may start ignoring streaming results it has been using and only use reporting results thereafter.

[0165] The streaming mode returns search results in real time, with minimal processing, in response to the search request. The reporting mode provides results of a search request with processing of the search results prior to providing them to the requesting search head, which in turn provides results to the requesting client device. ERP operation with such multiple modes provides greater performance flexibility with regard to report time, search latency, and resource utilization.

[0166] In a mixed mode operation, both streaming mode and reporting mode are operating simultaneously. The streaming mode results (e.g., the machine data obtained from the external data source) are provided to the search head, which can then process the results data (e.g., break the machine data into events, timestamp it, filter it, etc.) and integrate the results data with the results data from other external data sources, and/or from data stores of the search head. The search head performs such processing and can immediately start returning interim (streaming mode) results to the user at the requesting client device; simultaneously, the search head is waiting for the ERP process to process the data it is retrieving from the external data source as a result of the concurrently executing reporting mode.

[0167] In some instances, the ERP process initially operates in a mixed mode, such that the streaming mode operates to enable the ERP quickly to return interim results (e.g., some of the machined data or unprocessed data necessary to respond to a search request) to the search head, enabling the search head to process the interim results and begin providing to the client or search requester interim results that are responsive to the query. Meanwhile, in this mixed mode, the ERP also operates concurrently in reporting mode, processing portions of machine data in a manner responsive to the search query. Upon determining that it has results from the reporting mode available to return to the search head, the ERP may halt processing in the mixed mode at that time (or some later time) by stopping the return of data in streaming

mode to the search head and switching to reporting mode only. The ERP at this point starts sending interim results in reporting mode to the search head, which in turn may then present this processed data responsive to the search request to the client or search requester. Typically the search head switches from using results from the ERP’s streaming mode of operation to results from the ERP’s reporting mode of operation when the higher bandwidth results from the reporting mode outstrip the amount of data processed by the search head in the streaming mode of ERP operation.

[0168] A reporting mode may have a higher bandwidth because the ERP does not have to spend time transferring data to the search head for processing all the machine data. In addition, the ERP may optionally direct another processor to do the processing.

[0169] The streaming mode of operation does not need to be stopped to gain the higher bandwidth benefits of a reporting mode; the search head could simply stop using the streaming mode results—and start using the reporting mode results—when the bandwidth of the reporting mode has caught up with or exceeded the amount of bandwidth provided by the streaming mode. Thus, a variety of triggers and ways to accomplish a search head’s switch from using streaming mode results to using reporting mode results may be appreciated by one skilled in the art.

[0170] The reporting mode can involve the ERP process (or an external system) performing event breaking, time stamping, filtering of events to match the search query request, and calculating statistics on the results. The user can request particular types of data, such as if the search query itself involves types of events, or the search request may ask for statistics on data, such as on events that meet the search request. In either case, the search head understands the query language used in the received query request, which may be a proprietary language. One exemplary query language is Splunk Processing Language (SPL) developed by the assignee of the application, Splunk Inc. The search head typically understands how to use that language to obtain data from the indexers, which store data in a format used by the SPLUNK® Enterprise system.

[0171] The ERP processes support the search head, as the search head is not ordinarily configured to understand the format in which data is stored in external data sources such as Hadoop or SQL data systems. Rather, the ERP process performs that translation from the query submitted in the search support system’s native format (e.g., SPL if SPLUNK® ENTERPRISE is used as the search support system) to a search query request format that will be accepted by the corresponding external data system. The external data system typically stores data in a different format from that of the search support system’s native index format, and it utilizes a different query language (e.g., SQL or MapReduce, rather than SPL or the like).

[0172] As noted, the ERP process can operate in the streaming mode alone. After the ERP process has performed the translation of the query request and received raw results from the streaming mode, the search head can integrate the returned data with any data obtained from local data sources (e.g., native to the search support system), other external data sources, and other ERP processes (if such operations were required to satisfy the terms of the search query). An advantage of mixed mode operation is that, in addition to streaming mode, the ERP process is also executing concurrently in reporting mode. Thus, the ERP process (rather than

the search head) is processing query results (e.g., performing event breaking, timestamping, filtering, possibly calculating statistics if required to be responsive to the search query request, etc.). It should be apparent to those skilled in the art that additional time is needed for the ERP process to perform the processing in such a configuration. Therefore, the streaming mode will allow the search head to start returning interim results to the user at the client device before the ERP process can complete sufficient processing to start returning any search results. The switchover between streaming and reporting mode happens when the ERP process determines that the switchover is appropriate, such as when the ERP process determines it can begin returning meaningful results from its reporting mode.

[0173] The operation described above illustrates the source of operational latency: streaming mode has low latency (immediate results) and usually has relatively low bandwidth (fewer results can be returned per unit of time). In contrast, the concurrently running reporting mode has relatively high latency (it has to perform a lot more processing before returning any results) and usually has relatively high bandwidth (more results can be processed per unit of time). For example, when the ERP process does begin returning report results, it returns more processed results than in the streaming mode, because, e.g., statistics only need to be calculated to be responsive to the search request. That is, the ERP process doesn't have to take time to first return machine data to the search head. As noted, the ERP process could be configured to operate in streaming mode alone and return just the machine data for the search head to process in a way that is responsive to the search request. Alternatively, the ERP process can be configured to operate in the reporting mode only. Also, the ERP process can be configured to operate in streaming mode and reporting mode concurrently, as described, with the ERP process stopping the transmission of streaming results to the search head when the concurrently running reporting mode has caught up and started providing results. The reporting mode does not require the processing of all machine data that is responsive to the search query request before the ERP process starts returning results; rather, the reporting mode usually performs processing of chunks of events and returns the processing results to the search head for each chunk.

[0174] For example, an ERP process can be configured to merely return the contents of a search result file verbatim, with little or no processing of results. That way, the search head performs all processing (such as parsing byte streams into events, filtering, etc.). The ERP process can be configured to perform additional intelligence, such as analyzing the search request and handling all the computation that a native search indexer process would otherwise perform. In this way, the configured ERP process provides greater flexibility in features while operating according to desired preferences, such as response latency and resource requirements.

2.7. Data Ingestion

[0175] FIG. 5A is a flow chart of an example method that illustrates how indexers process, index, and store data received from forwarders, in accordance with example embodiments. The data flow illustrated in FIG. 5A is provided for illustrative purposes only; those skilled in the art would understand that one or more of the steps of the processes illustrated in FIG. 5A may be removed or that the

ordering of the steps may be changed. Furthermore, for the purposes of illustrating a clear example, one or more particular system components are described in the context of performing various operations during each of the data flow stages. For example, a forwarder is described as receiving and processing machine data during an input phase; an indexer is described as parsing and indexing machine data during parsing and indexing phases; and a search head is described as performing a search query during a search phase. However, other system arrangements and distributions of the processing steps across system components may be used.

[0176] 2.7.1. Input

[0177] At block 502, a forwarder receives data from an input source, such as a data source 202 shown in FIG. 2. A forwarder initially may receive the data as a raw data stream generated by the input source. For example, a forwarder may receive a data stream from a log file generated by an application server, from a stream of network data from a network device, or from any other source of data. In some embodiments, a forwarder receives the raw data and may segment the data stream into "blocks", possibly of a uniform data size, to facilitate subsequent processing steps.

[0178] At block 504, a forwarder or other system component annotates each block generated from the raw data with one or more metadata fields. These metadata fields may, for example, provide information related to the data block as a whole and may apply to each event that is subsequently derived from the data in the data block. For example, the metadata fields may include separate fields specifying each of a host, a source, and a source type related to the data block. A host field may contain a value identifying a host name or IP address of a device that generated the data. A source field may contain a value identifying a source of the data, such as a pathname of a file or a protocol and port related to received network data. A source type field may contain a value specifying a particular source type label for the data. Additional metadata fields may also be included during the input phase, such as a character encoding of the data, if known, and possibly other values that provide information relevant to later processing steps. In some embodiments, a forwarder forwards the annotated data blocks to another system component (typically an indexer) for further processing.

[0179] The data intake and query system allows forwarding of data from one data intake and query instance to another, or even to a third-party system. The data intake and query system can employ different types of forwarders in a configuration.

[0180] In some embodiments, a forwarder may contain the essential components needed to forward data. A forwarder can gather data from a variety of inputs and forward the data to an indexer for indexing and searching. A forwarder can also tag metadata (e.g., source, source type, host, etc.).

[0181] In some embodiments, a forwarder has the capabilities of the aforementioned forwarder as well as additional capabilities. The forwarder can parse data before forwarding the data (e.g., can associate a time stamp with a portion of data and create an event, etc.) and can route data based on criteria such as source or type of event. The forwarder can also index data locally while forwarding the data to another indexer.

[0182] 2.7.2. Parsing

[0183] At block **506**, an indexer receives data blocks from a forwarder and parses the data to organize the data into events. In some embodiments, to organize the data into events, an indexer may determine a source type associated with each data block (e.g., by extracting a source type label from the metadata fields associated with the data block, etc.) and refer to a source type configuration corresponding to the identified source type. The source type definition may include one or more properties that indicate to the indexer to automatically determine the boundaries within the received data that indicate the portions of machine data for events. In general, these properties may include regular expression-based rules or delimiter rules where, for example, event boundaries may be indicated by predefined characters or character strings. These predefined characters may include punctuation marks or other special characters including, for example, carriage returns, tabs, spaces, line breaks, etc. If a source type for the data is unknown to the indexer, an indexer may infer a source type for the data by examining the structure of the data. Then, the indexer can apply an inferred source type definition to the data to create the events.

[0184] At block **508**, the indexer determines a timestamp for each event. Similar to the process for parsing machine data, an indexer may again refer to a source type definition associated with the data to locate one or more properties that indicate instructions for determining a timestamp for each event. The properties may, for example, instruct an indexer to extract a time value from a portion of data for the event, to interpolate time values based on timestamps associated with temporally proximate events, to create a timestamp based on a time the portion of machine data was received or generated, to use the timestamp of a previous event, or use any other rules for determining timestamps.

[0185] At block **510**, the indexer associates with each event one or more metadata fields including a field containing the timestamp determined for the event. In some embodiments, a timestamp may be included in the metadata fields. These metadata fields may include any number of “default fields” that are associated with all events, and may also include one or more custom fields as defined by a user. Similar to the metadata fields associated with the data blocks at block **504**, the default metadata fields associated with each event may include a host, source, and source type field including or in addition to a field storing the timestamp.

[0186] At block **512**, an indexer may optionally apply one or more transformations to data included in the events created at block **506**. For example, such transformations can include removing a portion of an event (e.g., a portion used to define event boundaries, extraneous characters from the event, other extraneous text, etc.), masking a portion of an event (e.g., masking a credit card number), removing redundant portions of an event, etc. The transformations applied to events may, for example, be specified in one or more configuration files and referenced by one or more source type definitions.

[0187] FIG. **5C** illustrates an illustrative example of machine data can be stored in a data store in accordance with various disclosed embodiments. In other embodiments, machine data can be stored in a flat file in a corresponding bucket with an associated index file, such as a time series index or “TSIDX.” As such, the depiction of machine data and associated metadata as rows and columns in the table of

FIG. **5C** is merely illustrative and is not intended to limit the data format in which the machine data and metadata is stored in various embodiments described herein. In one particular embodiment, machine data can be stored in a compressed or encrypted formatted. In such embodiments, the machine data can be stored with or be associated with data that describes the compression or encryption scheme with which the machine data is stored. The information about the compression or encryption scheme can be used to decompress or decrypt the machine data, and any metadata with which it is stored, at search time.

[0188] As mentioned above, certain metadata, e.g., host **536**, source **537**, source type **538** and timestamps **535** can be generated for each event, and associated with a corresponding portion of machine data **539** when storing the event data in a data store, e.g., data store **208**. Any of the metadata can be extracted from the corresponding machine data, or supplied or defined by an entity, such as a user or computer system. The metadata fields can become part of or stored with the event. Note that while the time-stamp metadata field can be extracted from the raw data of each event, the values for the other metadata fields may be determined by the indexer based on information it receives pertaining to the source of the data separate from the machine data.

[0189] While certain default or user-defined metadata fields can be extracted from the machine data for indexing purposes, all the machine data within an event can be maintained in its original condition. As such, in embodiments in which the portion of machine data included in an event is unprocessed or otherwise unaltered, it is referred to herein as a portion of raw machine data. In other embodiments, the port of machine data in an event can be processed or otherwise altered. As such, unless certain information needs to be removed for some reasons (e.g. extraneous information, confidential information), all the raw machine data contained in an event can be preserved and saved in its original form. Accordingly, the data store in which the event records are stored is sometimes referred to as a “raw record data store.” The raw record data store contains a record of the raw event data tagged with the various default fields.

[0190] In FIG. **5C**, the first three rows of the table represent events **531**, **532**, and **533** and are related to a server access log that records requests from multiple clients processed by a server, as indicated by entry of “access.log” in the source column **536**.

[0191] In the example shown in FIG. **5C**, each of the events **531-534** is associated with a discrete request made from a client device. The raw machine data generated by the server and extracted from a server access log can include the IP address of the client **540**, the user id of the person requesting the document **541**, the time the server finished processing the request **542**, the request line from the client **543**, the status code returned by the server to the client **545**, the size of the object returned to the client (in this case, the gif file requested by the client) **546** and the time spent to serve the request in microseconds **544**. As seen in FIG. **5C**, all the raw machine data retrieved from the server access log is retained and stored as part of the corresponding events, **1221**, **1222**, and **1223** in the data store.

[0192] Event **534** is associated with an entry in a server error log, as indicated by “error.log” in the source column **537**, that records errors that the server encountered when processing a client request. Similar to the events related to the server access log, all the raw machine data in the error

log file pertaining to event **534** can be preserved and stored as part of the event **534**. Saving minimally processed or unprocessed machine data in a data store associated with metadata fields in the manner similar to that shown in FIG. **5C** is advantageous because it allows search of all the machine data at search time instead of searching only previously specified and identified fields or field-value pairs. As mentioned above, because data structures used by various embodiments of the present disclosure maintain the underlying raw machine data and use a late-binding schema for searching the raw machines data, it enables a user to continue investigating and learn valuable insights about the raw data. In other words, the user is not compelled to know about all the fields of information that will be needed at data ingestion time. As a user learns more about the data in the events, the user can continue to refine the late-binding schema by defining new extraction rules, or modifying or deleting existing extraction rules used by the system.

[0193] 2.7.3. Indexing

[0194] At blocks **514** and **516**, an indexer can optionally generate a keyword index to facilitate fast keyword searching for events. To build a keyword index, at block **514**, the indexer identifies a set of keywords in each event. At block **516**, the indexer includes the identified keywords in an index, which associates each stored keyword with reference pointers to events containing that keyword (or to locations within events where that keyword is located, other location identifiers, etc.). When an indexer subsequently receives a keyword-based query, the indexer can access the keyword index to quickly identify events containing the keyword.

[0195] In some embodiments, the keyword index may include entries for field name-value pairs found in events, where a field name-value pair can include a pair of keywords connected by a symbol, such as an equals sign or colon. This way, events containing these field name-value pairs can be quickly located. In some embodiments, fields can automatically be generated for some or all of the field names of the field name-value pairs at the time of indexing. For example, if the string “dest=10.0.1.2” is found in an event, a field named “dest” may be created for the event, and assigned a value of “10.0.1.2”.

[0196] At block **518**, the indexer stores the events with an associated timestamp in a data store **208**. Timestamps enable a user to search for events based on a time range. In some embodiments, the stored events are organized into “buckets,” where each bucket stores events associated with a specific time range based on the timestamps associated with each event. This improves time-based searching, as well as allows for events with recent timestamps, which may have a higher likelihood of being accessed, to be stored in a faster memory to facilitate faster retrieval. For example, buckets containing the most recent events can be stored in flash memory rather than on a hard disk. In some embodiments, each bucket may be associated with an identifier, a time range, and a size constraint.

[0197] Each indexer **206** may be responsible for storing and searching a subset of the events contained in a corresponding data store **208**. By distributing events among the indexers and data stores, the indexers can analyze events for a query in parallel. For example, using map-reduce techniques, each indexer returns partial responses for a subset of events to a search head that combines the results to produce an answer for the query. By storing events in buckets for specific time ranges, an indexer may further optimize the

data retrieval process by searching buckets corresponding to time ranges that are relevant to a query.

[0198] In some embodiments, each indexer has a home directory and a cold directory. The home directory of an indexer stores hot buckets and warm buckets, and the cold directory of an indexer stores cold buckets. A hot bucket is a bucket that is capable of receiving and storing events. A warm bucket is a bucket that can no longer receive events for storage but has not yet been moved to the cold directory. A cold bucket is a bucket that can no longer receive events and may be a bucket that was previously stored in the home directory. The home directory may be stored in faster memory, such as flash memory, as events may be actively written to the home directory, and the home directory may typically store events that are more frequently searched and thus are accessed more frequently. The cold directory may be stored in slower and/or larger memory, such as a hard disk, as events are no longer being written to the cold directory, and the cold directory may typically store events that are not as frequently searched and thus are accessed less frequently. In some embodiments, an indexer may also have a quarantine bucket that contains events having potentially inaccurate information, such as an incorrect time stamp associated with the event or a time stamp that appears to be an unreasonable time stamp for the corresponding event. The quarantine bucket may have events from any time range; as such, the quarantine bucket may always be searched at search time. Additionally, an indexer may store old, archived data in a frozen bucket that is not capable of being searched at search time. In some embodiments, a frozen bucket may be stored in slower and/or larger memory, such as a hard disk, and may be stored in offline and/or remote storage.

[0199] Moreover, events and buckets can also be replicated across different indexers and data stores to facilitate high availability and disaster recovery as described in U.S. Pat. No. 9,130,971, entitled “SITE-BASED SEARCH AFFINITY”, issued on 8 Sep. 2015, and in U.S. patent Ser. No. 14/266,817, entitled “MULTI-SITE CLUSTERING”, issued on 1 Sep. 2015, each of which is hereby incorporated by reference in its entirety for all purposes.

[0200] FIG. **5B** is a block diagram of an example data store **501** that includes a directory for each index (or partition) that contains a portion of data managed by an indexer. FIG. **5B** further illustrates details of an embodiment of an inverted index **507B** and an event reference array **515** associated with inverted index **507B**.

[0201] The data store **501** can correspond to a data store **208** that stores events managed by an indexer **206** or can correspond to a different data store associated with an indexer **206**. In the illustrated embodiment, the data store **501** includes a `_main` directory **503** associated with a main index and a `_test` directory **505** associated with a `_test` index. However, the data store **501** can include fewer or more directories. In some embodiments, multiple indexes can share a single directory or all indexes can share a common directory. Additionally, although illustrated as a single data store **501**, it will be understood that the data store **501** can be implemented as multiple data stores storing different portions of the information shown in FIG. **5B**. For example, a single index or partition can span multiple directories or multiple data stores, and can be indexed or searched by multiple corresponding indexers.

[0202] In the illustrated embodiment of FIG. 5B, the index-specific directories 503 and 505 include inverted indexes 507A, 507B and 509A, 509B, respectively. The inverted indexes 507A . . . 507B, and 509A . . . 509B can be keyword indexes or field-value pair indexes described hereinafter and can include less or more information that depicted in FIG. 5B.

[0203] In some embodiments, the inverted index 507A . . . 507B, and 509A . . . 509B can correspond to a distinct time-series bucket that is managed by the indexer 206 and that contains events corresponding to the relevant index (e.g., _main index, _test index). As such, each inverted index can correspond to a particular range of time for an index. Additional files, such as high performance indexes for each time-series bucket of an index, can also be stored in the same directory as the inverted indexes 507A . . . 507B, and 509A . . . 509B. In some embodiments inverted index 507A . . . 507B, and 509A . . . 509B can correspond to multiple time-series buckets or inverted indexes 507A . . . 507B, and 509A . . . 509B can correspond to a single time-series bucket.

[0204] Each inverted index 507A . . . 507B, and 509A . . . 509B can include one or more entries, such as keyword (or token) entries or field-value pair entries. Furthermore, in certain embodiments, the inverted indexes 507A . . . 507B, and 509A . . . 509B can include additional information, such as a time range 523 associated with the inverted index or an index identifier 525 identifying the index associated with the inverted index 507A . . . 507B, and 509A . . . 509B. However, each inverted index 507A . . . 507B, and 509A . . . 509B can include less or more information than depicted.

[0205] Token entries, such as token entries 511 illustrated in inverted index 507B, can include a token 511A (e.g., “error,” “itemID,” etc.) and event references 511B indicative of events that include the token. For example, for the token “error,” the corresponding token entry includes the token “error” and an event reference, or unique identifier, for each event stored in the corresponding time-series bucket that includes the token “error.” In the illustrated embodiment of FIG. 5B, the error token entry includes the identifiers 3, 5, 6, 8, 11, and 12 corresponding to events managed by the indexer 206 and associated with the index_main 503 that are located in the time-series bucket associated with the inverted index 507B.

[0206] In some cases, some token entries can be default entries, automatically determined entries, or user specified entries. In some embodiments, the indexer 206 can identify each word or string in an event as a distinct token and generate a token entry for it. In some cases, the indexer 206 can identify the beginning and ending of tokens based on punctuation, spaces, as described in greater detail herein. In certain cases, the indexer 206 can rely on user input or a configuration file to identify tokens for token entries 511, etc. It will be understood that any combination of token entries can be included as a default, automatically determined, or included based on user-specified criteria.

[0207] Similarly, field-value pair entries, such as field-value pair entries 513 shown in inverted index 507B, can include a field-value pair 513A and event references 513B indicative of events that include a field value that corresponds to the field-value pair. For example, for a field-value pair sourcetype::sendmail, a field-value pair entry would include the field-value pair sourcetype::sendmail and a

unique identifier, or event reference, for each event stored in the corresponding time-series bucket that includes a send-mail sourcetype.

[0208] In some cases, the field-value pair entries 513 can be default entries, automatically determined entries, or user specified entries. As a non-limiting example, the field-value pair entries for the fields host, source, sourcetype can be included in the inverted indexes 507A . . . 507B, and 509A . . . 509B as a default. As such, all of the inverted indexes 507A . . . 507B, and 509A . . . 509B can include field-value pair entries for the fields host, source, sourcetype. As yet another non-limiting example, the field-value pair entries for the IP_address field can be user specified and may only appear in the inverted index 507B based on user-specified criteria. As another non-limiting example, as the indexer indexes the events, it can automatically identify field-value pairs and create field-value pair entries. For example, based on the indexers review of events, it can identify IP_address as a field in each event and add the IP_address field-value pair entries to the inverted index 507B. It will be understood that any combination of field-value pair entries can be included as a default, automatically determined, or included based on user-specified criteria.

[0209] Each unique identifier 517, or event reference, can correspond to a unique event located in the time series bucket. However, the same event reference can be located in multiple entries. For example if an event has a sourcetype splunkd, host www1 and token “warning,” then the unique identifier for the event will appear in the field-value pair entries sourcetype::splunkd and host::www1, as well as the token entry “warning.” With reference to the illustrated embodiment of FIG. 5B and the event that corresponds to the event reference 3, the event reference 3 is found in the field-value pair entries 513 host::hostA, source::sourceB, sourcetype::sourcetypeA, and IP_address::91.205.189.15 indicating that the event corresponding to the event references is from hostA, sourceB, of sourcetypeA, and includes 91.205.189.15 in the event data.

[0210] For some fields, the unique identifier is located in only one field-value pair entry for a particular field. For example, the inverted index may include four sourcetype field-value pair entries corresponding to four different sourcetypes of the events stored in a bucket (e.g., sourcetypes: sendmail, splunkd, web_access, and web_service). Within those four sourcetype field-value pair entries, an identifier for a particular event may appear in only one of the field-value pair entries. With continued reference to the example illustrated embodiment of FIG. 5B, since the event reference 7 appears in the field-value pair entry sourcetype::sourcetypeA, then it does not appear in the other field-value pair entries for the sourcetype field, including sourcetype::sourcetypeB, sourcetype::sourcetypeC, and sourcetype::sourcetypeD.

[0211] The event references 517 can be used to locate the events in the corresponding bucket. For example, the inverted index can include, or be associated with, an event reference array 515. The event reference array 515 can include an array entry 517 for each event reference in the inverted index 507B. Each array entry 517 can include location information 519 of the event corresponding to the unique identifier (non-limiting example: seek address of the event), a timestamp 521 associated with the event, or additional information regarding the event associated with the event reference, etc.

[0212] For each token entry **511** or field-value pair entry **513**, the event reference **501B** or unique identifiers can be listed in chronological order or the value of the event reference can be assigned based on chronological data, such as a timestamp associated with the event referenced by the event reference. For example, the event reference 1 in the illustrated embodiment of FIG. **5B** can correspond to the first-in-time event for the bucket, and the event reference 12 can correspond to the last-in-time event for the bucket. However, the event references can be listed in any order, such as reverse chronological order, ascending order, descending order, or some other order, etc. Further, the entries can be sorted. For example, the entries can be sorted alphabetically (collectively or within a particular group), by entry origin (e.g., default, automatically generated, user-specified, etc.), by entry type (e.g., field-value pair entry, token entry, etc.), or chronologically by when added to the inverted index, etc. In the illustrated embodiment of FIG. **5B**, the entries are sorted first by entry type and then alphabetically.

[0213] As a non-limiting example of how the inverted indexes **507A . . . 507B**, and **509A . . . 509B** can be used during a data categorization request command, the indexers can receive filter criteria indicating data that is to be categorized and categorization criteria indicating how the data is to be categorized. Example filter criteria can include, but is not limited to, indexes (or partitions), hosts, sources, sourcetypes, time ranges, field identifier, keywords, etc.

[0214] Using the filter criteria, the indexer identifies relevant inverted indexes to be searched. For example, if the filter criteria includes a set of partitions, the indexer can identify the inverted indexes stored in the directory corresponding to the particular partition as relevant inverted indexes. Other means can be used to identify inverted indexes associated with a partition of interest. For example, in some embodiments, the indexer can review an entry in the inverted indexes, such as an index-value pair entry **513** to determine if a particular inverted index is relevant. If the filter criteria does not identify any partition, then the indexer can identify all inverted indexes managed by the indexer as relevant inverted indexes.

[0215] Similarly, if the filter criteria includes a time range, the indexer can identify inverted indexes corresponding to buckets that satisfy at least a portion of the time range as relevant inverted indexes. For example, if the time range is last hour then the indexer can identify all inverted indexes that correspond to buckets storing events associated with timestamps within the last hour as relevant inverted indexes.

[0216] When used in combination, an index filter criterion specifying one or more partitions and a time range filter criterion specifying a particular time range can be used to identify a subset of inverted indexes within a particular directory (or otherwise associated with a particular partition) as relevant inverted indexes. As such, the indexer can focus the processing to only a subset of the total number of inverted indexes that the indexer manages.

[0217] Once the relevant inverted indexes are identified, the indexer can review them using any additional filter criteria to identify events that satisfy the filter criteria. In some cases, using the known location of the directory in which the relevant inverted indexes are located, the indexer can determine that any events identified using the relevant inverted indexes satisfy an index filter criterion. For example, if the filter criteria includes a partition main, then

the indexer can determine that any events identified using inverted indexes within the partition main directory (or otherwise associated with the partition main) satisfy the index filter criterion.

[0218] Furthermore, based on the time range associated with each inverted index, the indexer can determine that any events identified using a particular inverted index satisfies a time range filter criterion. For example, if a time range filter criterion is for the last hour and a particular inverted index corresponds to events within a time range of 50 minutes ago to 35 minutes ago, the indexer can determine that any events identified using the particular inverted index satisfy the time range filter criterion. Conversely, if the particular inverted index corresponds to events within a time range of 59 minutes ago to 62 minutes ago, the indexer can determine that some events identified using the particular inverted index may not satisfy the time range filter criterion.

[0219] Using the inverted indexes, the indexer can identify event references (and therefore events) that satisfy the filter criteria. For example, if the token "error" is a filter criterion, the indexer can track all event references within the token entry "error." Similarly, the indexer can identify other event references located in other token entries or field-value pair entries that match the filter criteria. The system can identify event references located in all of the entries identified by the filter criteria. For example, if the filter criteria include the token "error" and field-value pair sourcetype::web_ui, the indexer can track the event references found in both the token entry "error" and the field-value pair entry sourcetype::web_ui. As mentioned previously, in some cases, such as when multiple values are identified for a particular filter criterion (e.g., multiple sources for a source filter criterion), the system can identify event references located in at least one of the entries corresponding to the multiple values and in all other entries identified by the filter criteria. The indexer can determine that the events associated with the identified event references satisfy the filter criteria.

[0220] In some cases, the indexer can further consult a timestamp associated with the event reference to determine whether an event satisfies the filter criteria. For example, if an inverted index corresponds to a time range that is partially outside of a time range filter criterion, then the indexer can consult a timestamp associated with the event reference to determine whether the corresponding event satisfies the time range criterion. In some embodiments, to identify events that satisfy a time range, the indexer can review an array, such as the event reference array **1614** that identifies the time associated with the events. Furthermore, as mentioned above using the known location of the directory in which the relevant inverted indexes are located (or other index identifier), the indexer can determine that any events identified using the relevant inverted indexes satisfy the index filter criterion.

[0221] In some cases, based on the filter criteria, the indexer reviews an extraction rule. In certain embodiments, if the filter criteria includes a field name that does not correspond to a field-value pair entry in an inverted index, the indexer can review an extraction rule, which may be located in a configuration file, to identify a field that corresponds to a field-value pair entry in the inverted index.

[0222] For example, the filter criteria includes a field name "sessionId" and the indexer determines that at least one relevant inverted index does not include a field-value pair entry corresponding to the field name sessionId, the indexer

can review an extraction rule that identifies how the sessionID field is to be extracted from a particular host, source, or sourcetype (implicitly identifying the particular host, source, or sourcetype that includes a sessionID field). The indexer can replace the field name “sessionID” in the filter criteria with the identified host, source, or sourcetype. In some cases, the field name “sessionID” may be associated with multiples hosts, sources, or sourcetypes, in which case, all identified hosts, sources, and sourcetypes can be added as filter criteria. In some cases, the identified host, source, or sourcetype can replace or be appended to a filter criterion, or be excluded. For example, if the filter criteria includes a criterion for source S1 and the “sessionID” field is found in source S2, the source S2 can replace S1 in the filter criteria, be appended such that the filter criteria includes source S1 and source S2, or be excluded based on the presence of the filter criterion source S1. If the identified host, source, or sourcetype is included in the filter criteria, the indexer can then identify a field-value pair entry in the inverted index that includes a field value corresponding to the identity of the particular host, source, or sourcetype identified using the extraction rule.

[0223] Once the events that satisfy the filter criteria are identified, the system, such as the indexer **206** can categorize the results based on the categorization criteria. The categorization criteria can include categories for grouping the results, such as any combination of partition, source, sourcetype, or host, or other categories or fields as desired.

[0224] The indexer can use the categorization criteria to identify categorization criteria-value pairs or categorization criteria values by which to categorize or group the results. The categorization criteria-value pairs can correspond to one or more field-value pair entries stored in a relevant inverted index, one or more index-value pairs based on a directory in which the inverted index is located or an entry in the inverted index (or other means by which an inverted index can be associated with a partition), or other criteria-value pair that identifies a general category and a particular value for that category. The categorization criteria values can correspond to the value portion of the categorization criteria-value pair.

[0225] As mentioned, in some cases, the categorization criteria-value pairs can correspond to one or more field-value pair entries stored in the relevant inverted indexes. For example, the categorization criteria-value pairs can correspond to field-value pair entries of host, source, and sourcetype (or other field-value pair entry as desired). For instance, if there are ten different hosts, four different sources, and five different sourcetypes for an inverted index, then the inverted index can include ten host field-value pair entries, four source field-value pair entries, and five sourcetype field-value pair entries. The indexer can use the nineteen distinct field-value pair entries as categorization criteria-value pairs to group the results.

[0226] Specifically, the indexer can identify the location of the event references associated with the events that satisfy the filter criteria within the field-value pairs, and group the event references based on their location. As such, the indexer can identify the particular field value associated with the event corresponding to the event reference. For example, if the categorization criteria include host and sourcetype, the host field-value pair entries and sourcetype field-value pair entries can be used as categorization criteria-value pairs to

identify the specific host and sourcetype associated with the events that satisfy the filter criteria.

[0227] In addition, as mentioned, categorization criteria-value pairs can correspond to data other than the field-value pair entries in the relevant inverted indexes. For example, if partition or index is used as a categorization criterion, the inverted indexes may not include partition field-value pair entries. Rather, the indexer can identify the categorization criteria-value pair associated with the partition based on the directory in which an inverted index is located, information in the inverted index, or other information that associates the inverted index with the partition, etc. As such a variety of methods can be used to identify the categorization criteria-value pairs from the categorization criteria.

[0228] Accordingly based on the categorization criteria (and categorization criteria-value pairs), the indexer can generate groupings based on the events that satisfy the filter criteria. As a non-limiting example, if the categorization criteria includes a partition and sourcetype, then the groupings can correspond to events that are associated with each unique combination of partition and sourcetype. For instance, if there are three different partitions and two different sourcetypes associated with the identified events, then the six different groups can be formed, each with a unique partition value-sourcetype value combination. Similarly, if the categorization criteria includes partition, sourcetype, and host and there are two different partitions, three sourcetypes, and five hosts associated with the identified events, then the indexer can generate up to thirty groups for the results that satisfy the filter criteria. Each group can be associated with a unique combination of categorization criteria-value pairs (e.g., unique combinations of partition value sourcetype value, and host value).

[0229] In addition, the indexer can count the number of events associated with each group based on the number of events that meet the unique combination of categorization criteria for a particular group (or match the categorization criteria-value pairs for the particular group). With continued reference to the example above, the indexer can count the number of events that meet the unique combination of partition, sourcetype, and host for a particular group.

[0230] Each indexer communicates the groupings to the search head. The search head can aggregate the groupings from the indexers and provide the groupings for display. In some cases, the groups are displayed based on at least one of the host, source, sourcetype, or partition associated with the groupings. In some embodiments, the search head can further display the groups based on display criteria, such as a display order or a sort order as described in greater detail above.

[0231] As a non-limiting example and with reference to FIG. 5B, consider a request received by an indexer **206** that includes the following filter criteria: keyword=error, partition=_main, time range=3/1/17 16:22.00.000-16:28.00.000, sourcetype=sourcetypeC, host=hostB, and the following categorization criteria: source.

[0232] Based on the above criteria, the indexer **206** identifies _main directory **503** and can ignore _test directory **505** and any other partition-specific directories. The indexer determines that inverted partition **507B** is a relevant partition based on its location within the _main directory **503** and the time range associated with it. For sake of simplicity in this example, the indexer **206** determines that no other

inverted indexes in the `_main` directory **503**, such as inverted index **507A** satisfy the time range criterion.

[0233] Having identified the relevant inverted index **507B**, the indexer reviews the token entries **511** and the field-value pair entries **513** to identify event references, or events, that satisfy all of the filter criteria.

[0234] With respect to the token entries **511**, the indexer can review the error token entry and identify event references 3, 5, 6, 8, 11, 12, indicating that the term “error” is found in the corresponding events. Similarly, the indexer can identify event references 4, 5, 6, 8, 9, 10, 11 in the field-value pair entry `sourcetype::sourcetypeC` and event references 2, 5, 6, 8, 10, 11 in the field-value pair entry `host::hostB`. As the filter criteria did not include a source or an `IP_address` field-value pair, the indexer can ignore those field-value pair entries.

[0235] In addition to identifying event references found in at least one token entry or field-value pair entry (e.g., event references 3, 4, 5, 6, 8, 9, 10, 11, 12), the indexer can identify events (and corresponding event references) that satisfy the time range criterion using the event reference array **1614** (e.g., event references 2, 3, 4, 5, 6, 7, 8, 9, 10). Using the information obtained from the inverted index **507B** (including the event reference array **515**), the indexer **206** can identify the event references that satisfy all of the filter criteria (e.g., event references 5, 6, 8).

[0236] Having identified the events (and event references) that satisfy all of the filter criteria, the indexer **206** can group the event references using the received categorization criteria (source). In doing so, the indexer can determine that event references 5 and 6 are located in the field-value pair entry `source::sourceD` (or have matching categorization criteria-value pairs) and event reference 8 is located in the field-value pair entry `source::sourceC`. Accordingly, the indexer can generate a `sourceC` group having a count of one corresponding to reference 8 and a `sourceD` group having a count of two corresponding to references 5 and 6. This information can be communicated to the search head. In turn the search head can aggregate the results from the various indexers and display the groupings. As mentioned above, in some embodiments, the groupings can be displayed based at least in part on the categorization criteria, including at least one of host, source, sourcetype, or partition.

[0237] It will be understood that a change to any of the filter criteria or categorization criteria can result in different groupings. As a one non-limiting example, a request received by an indexer **206** that includes the following filter criteria: `partition=_main, time range=3/1/17 3/1/17 16:21:20.000-16:28:17.000`, and the following categorization criteria: `host, source, sourcetype` would result in the indexer identifying event references 1-12 as satisfying the filter criteria. The indexer would then generate up to 24 groupings corresponding to the 24 different combinations of the categorization criteria-value pairs, including `host (hostA, hostB)`, `source (sourceA, sourceB, sourceC, sourceD)`, and `sourcetype (sourcetypeA, sourcetypeB, sourcetypeC)`. However, as there are only twelve events identifiers in the illustrated embodiment and some fall into the same grouping, the indexer generates eight groups and counts as follows:

[0238] Group 1 (`hostA, sourceA, sourcetypeA`): 1 (event reference 7)

[0239] Group 2 (`hostA, sourceA, sourcetypeB`): 2 (event references 1, 12)

[0240] Group 3 (`hostA, sourceA, sourcetypeC`): 1 (event reference 4)

[0241] Group 4 (`hostA, sourceB, sourcetypeA`): 1 (event reference 3)

[0242] Group 5 (`hostA, sourceB, sourcetypeC`): 1 (event reference 9)

[0243] Group 6 (`hostB, sourceC, sourcetypeA`): 1 (event reference 2)

[0244] Group 7 (`hostB, sourceC, sourcetypeC`): 2 (event references 8, 11)

[0245] Group 8 (`hostB, sourceD, sourcetypeC`): 3 (event references 5, 6, 10)

[0246] As noted, each group has a unique combination of categorization criteria-value pairs or categorization criteria values. The indexer communicates the groups to the search head for aggregation with results received from other indexers. In communicating the groups to the search head, the indexer can include the categorization criteria-value pairs for each group and the count. In some embodiments, the indexer can include more or less information. For example, the indexer can include the event references associated with each group and other identifying information, such as the indexer or inverted index used to identify the groups.

[0247] As another non-limiting examples, a request received by an indexer **206** that includes the following filter criteria: `partition=_main, time range=3/1/17 3/1/17 16:21:20.000-16:28:17.000, source=sourceA, sourceD, and keyword=itemID` and the following categorization criteria: `host, source, sourcetype` would result in the indexer identifying event references 4, 7, and 10 as satisfying the filter criteria, and generate the following groups:

[0248] Group 1 (`hostA, sourceA, sourcetypeC`): 1 (event reference 4)

[0249] Group 2 (`hostA, sourceA, sourcetypeA`): 1 (event reference 7)

[0250] Group 3 (`hostB, sourceD, sourcetypeC`): 1 (event references 10)

[0251] The indexer communicates the groups to the search head for aggregation with results received from other indexers. As will be understood there are myriad ways for filtering and categorizing the events and event references. For example, the indexer can review multiple inverted indexes associated with an partition or review the inverted indexes of multiple partitions, and categorize the data using any one or any combination of partition, host, source, sourcetype, or other category, as desired.

[0252] Further, if a user interacts with a particular group, the indexer can provide additional information regarding the group. For example, the indexer can perform a targeted search or sampling of the events that satisfy the filter criteria and the categorization criteria for the selected group, also referred to as the filter criteria corresponding to the group or filter criteria associated with the group.

[0253] In some cases, to provide the additional information, the indexer relies on the inverted index. For example, the indexer can identify the event references associated with the events that satisfy the filter criteria and the categorization criteria for the selected group and then use the event reference array **515** to access some or all of the identified events. In some cases, the categorization criteria values or categorization criteria-value pairs associated with the group become part of the filter criteria for the review.

[0254] With reference to FIG. 5B for instance, suppose a group is displayed with a count of six corresponding to event

references 4, 5, 6, 8, 10, 11 (i.e., event references 4, 5, 6, 8, 10, 11 satisfy the filter criteria and are associated with matching categorization criteria values or categorization criteria-value pairs) and a user interacts with the group (e.g., selecting the group, clicking on the group, etc.). In response, the search head communicates with the indexer to provide additional information regarding the group.

[0255] In some embodiments, the indexer identifies the event references associated with the group using the filter criteria and the categorization criteria for the group (e.g., categorization criteria values or categorization criteria-value pairs unique to the group). Together, the filter criteria and the categorization criteria for the group can be referred to as the filter criteria associated with the group. Using the filter criteria associated with the group, the indexer identifies event references 4, 5, 6, 8, 10, 11.

[0256] Based on a sampling criteria, discussed in greater detail above, the indexer can determine that it will analyze a sample of the events associated with the event references 4, 5, 6, 8, 10, 11. For example, the sample can include analyzing event data associated with the event references 5, 8, 10. In some embodiments, the indexer can use the event reference array **1616** to access the event data associated with the event references 5, 8, 10. Once accessed, the indexer can compile the relevant information and provide it to the search head for aggregation with results from other indexers. By identifying events and sampling event data using the inverted indexes, the indexer can reduce the amount of actual data this is analyzed and the number of events that are accessed in order to generate the summary of the group and provide a response in less time.

2.8. Query Processing

[0257] FIG. 6A is a flow diagram of an example method that illustrates how a search head and indexers perform a search query, in accordance with example embodiments. At block **602**, a search head receives a search query from a client. At block **604**, the search head analyzes the search query to determine what portion(s) of the query can be delegated to indexers and what portions of the query can be executed locally by the search head. At block **606**, the search head distributes the determined portions of the query to the appropriate indexers. In some embodiments, a search head cluster may take the place of an independent search head where each search head in the search head cluster coordinates with peer search heads in the search head cluster to schedule jobs, replicate search results, update configurations, fulfill search requests, etc. In some embodiments, the search head (or each search head) communicates with a master node (also known as a cluster master, not shown in FIG. 2) that provides the search head with a list of indexers to which the search head can distribute the determined portions of the query. The master node maintains a list of active indexers and can also designate which indexers may have responsibility for responding to queries over certain sets of events. A search head may communicate with the master node before the search head distributes queries to indexers to discover the addresses of active indexers.

[0258] At block **608**, the indexers to which the query was distributed, search data stores associated with them for events that are responsive to the query. To determine which events are responsive to the query, the indexer searches for events that match the criteria specified in the query. These criteria can include matching keywords or specific values for

certain fields. The searching operations at block **608** may use the late-binding schema to extract values for specified fields from events at the time the query is processed. In some embodiments, one or more rules for extracting field values may be specified as part of a source type definition in a configuration file. The indexers may then either send the relevant events back to the search head, or use the events to determine a partial result, and send the partial result back to the search head.

[0259] At block **610**, the search head combines the partial results and/or events received from the indexers to produce a final result for the query. In some examples, the results of the query are indicative of performance or security of the IT environment and may help improve the performance of components in the IT environment. This final result may comprise different types of data depending on what the query requested. For example, the results can include a listing of matching events returned by the query, or some type of visualization of the data from the returned events. In another example, the final result can include one or more calculated values derived from the matching events.

[0260] The results generated by the system **108** can be returned to a client using different techniques. For example, one technique streams results or relevant events back to a client in real-time as they are identified. Another technique waits to report the results to the client until a complete set of results (which may include a set of relevant events or a result based on relevant events) is ready to return to the client. Yet another technique streams interim results or relevant events back to the client in real-time until a complete set of results is ready, and then returns the complete set of results to the client. In another technique, certain results are stored as “search jobs” and the client may retrieve the results by referring the search jobs.

[0261] The search head can also perform various operations to make the search more efficient. For example, before the search head begins execution of a query, the search head can determine a time range for the query and a set of common keywords that all matching events include. The search head may then use these parameters to query the indexers to obtain a superset of the eventual results. Then, during a filtering stage, the search head can perform field-extraction operations on the superset to produce a reduced set of search results. This speeds up queries, which may be particularly helpful for queries that are performed on a periodic basis.

2.9. Pipelined Search Language

[0262] Various embodiments of the present disclosure can be implemented using, or in conjunction with, a pipelined command language. A pipelined command language is a language in which a set of inputs or data is operated on by a first command in a sequence of commands, and then subsequent commands in the order they are arranged in the sequence. Such commands can include any type of functionality for operating on data, such as retrieving, searching, filtering, aggregating, processing, transmitting, and the like. As described herein, a query can thus be formulated in a pipelined command language and include any number of ordered or unordered commands for operating on data.

[0263] Splunk Processing Language (SPL) is an example of a pipelined command language in which a set of inputs or data is operated on by any number of commands in a particular sequence. A sequence of commands, or command

sequence, can be formulated such that the order in which the commands are arranged defines the order in which the commands are applied to a set of data or the results of an earlier executed command. For example, a first command in a command sequence can operate to search or filter for specific data in particular set of data. The results of the first command can then be passed to another command listed later in the command sequence for further processing.

[0264] In various embodiments, a query can be formulated as a command sequence defined in a command line of a search UI. In some embodiments, a query can be formulated as a sequence of SPL commands. Some or all of the SPL commands in the sequence of SPL commands can be separated from one another by a pipe symbol “|”. In such embodiments, a set of data, such as a set of events, can be operated on by a first SPL command in the sequence, and then a subsequent SPL command following a pipe symbol “|” after the first SPL command operates on the results produced by the first SPL command or other set of data, and so on for any additional SPL commands in the sequence. As such, a query formulated using SPL comprises a series of consecutive commands that are delimited by pipe “|” characters. The pipe character indicates to the system that the output or result of one command (to the left of the pipe) should be used as the input for one of the subsequent commands (to the right of the pipe). This enables formulation of queries defined by a pipeline of sequenced commands that refines or enhances the data at each step along the pipeline until the desired results are attained. Accordingly, various embodiments described herein can be implemented with Splunk Processing Language (SPL) used in conjunction with the SPLUNK® ENTERPRISE system.

[0265] While a query can be formulated in many ways, a query can start with a search command and one or more corresponding search terms at the beginning of the pipeline. Such search terms can include any combination of keywords, phrases, times, dates, Boolean expressions, field-name-field value pairs, etc. that specify which results should be obtained from an index. The results can then be passed as inputs into subsequent commands in a sequence of commands by using, for example, a pipe character. The subsequent commands in a sequence can include directives for additional processing of the results once it has been obtained from one or more indexes. For example, commands may be used to filter unwanted information out of the results, extract more information, evaluate field values, calculate statistics, reorder the results, create an alert, create summary of the results, or perform some type of aggregation function. In some embodiments, the summary can include a graph, chart, metric, or other visualization of the data. An aggregation function can include analysis or calculations to return an aggregate value, such as an average value, a sum, a maximum value, a root mean square, statistical values, and the like.

[0266] Due to its flexible nature, use of a pipelined command language in various embodiments is advantageous because it can perform “filtering” as well as “processing” functions. In other words, a single query can include a search command and search term expressions, as well as data-analysis expressions. For example, a command at the beginning of a query can perform a “filtering” step by retrieving a set of data based on a condition (e.g., records associated with server response times of less than 1 microsecond). The results of the filtering step can then be passed to a subse-

quent command in the pipeline that performs a “processing” step (e.g. calculation of an aggregate value related to the filtered events such as the average response time of servers with response times of less than 1 microsecond). Furthermore, the search command can allow events to be filtered by keyword as well as field value criteria. For example, a search command can filter out all events containing the word “warning” or filter out all events where a field value associated with a field “clientip” is “10.0.1.2.”

[0267] The results obtained or generated in response to a command in a query can be considered a set of results data. The set of results data can be passed from one command to another in any data format. In one embodiment, the set of result data can be in the form of a dynamically created table. Each command in a particular query can redefine the shape of the table. In some implementations, an event retrieved from an index in response to a query can be considered a row with a column for each field value. Columns contain basic information about the data and also may contain data that has been dynamically extracted at search time.

[0268] FIG. 6B provides a visual representation of the manner in which a pipelined command language or query operates in accordance with the disclosed embodiments. The query 630 can be inputted by the user into a search. The query comprises a search, the results of which are piped to two commands (namely, command 1 and command 2) that follow the search step.

[0269] Disk 622 represents the event data in the raw record data store.

[0270] When a user query is processed, a search step will precede other queries in the pipeline in order to generate a set of events at block 640. For example, the query can comprise search terms “sourcetype=syslog ERROR” at the front of the pipeline as shown in FIG. 6B. Intermediate results table 624 shows fewer rows because it represents the subset of events retrieved from the index that matched the search terms “sourcetype=syslog ERROR” from search command 630. By way of further example, instead of a search step, the set of events at the head of the pipeline may be generating by a call to a pre-existing inverted index (as will be explained later).

[0271] At block 642, the set of events generated in the first part of the query may be piped to a query that searches the set of events for field-value pairs or for keywords. For example, the second intermediate results table 626 shows fewer columns, representing the result of the top command, “top user” which summarizes the events into a list of the top 10 users and displays the user, count, and percentage.

[0272] Finally, at block 644, the results of the prior stage can be pipelined to another stage where further filtering or processing of the data can be performed, e.g., preparing the data for display purposes, filtering the data based on a condition, performing a mathematical calculation with the data, etc. As shown in FIG. 6B, the “fields—percent” part of command 630 removes the column that shows the percentage, thereby, leaving a final results table 628 without a percentage column. In different embodiments, other query languages, such as the Structured Query Language (“SQL”), can be used to create a query.

2.10. Field Extraction

[0273] The search head 210 allows users to search and visualize events generated from machine data received from homogenous data sources. The search head 210 also allows

users to search and visualize events generated from machine data received from heterogeneous data sources. The search head **210** includes various mechanisms, which may additionally reside in an indexer **206**, for processing a query. A query language may be used to create a query, such as any suitable pipelined query language. For example, Splunk Processing Language (SPL) can be utilized to make a query. SPL is a pipelined search language in which a set of inputs is operated on by a first command in a command line, and then a subsequent command following the pipe symbol “|” operates on the results produced by the first command, and so on for additional commands. Other query languages, such as the Structured Query Language (“SQL”), can be used to create a query.

[0274] In response to receiving the search query, search head **210** uses extraction rules to extract values for fields in the events being searched. The search head **210** obtains extraction rules that specify how to extract a value for fields from an event. Extraction rules can comprise regex rules that specify how to extract values for the fields corresponding to the extraction rules. In addition to specifying how to extract field values, the extraction rules may also include instructions for deriving a field value by performing a function on a character string or value retrieved by the extraction rule. For example, an extraction rule may truncate a character string or convert the character string into a different data format. In some cases, the query itself can specify one or more extraction rules.

[0275] The search head **210** can apply the extraction rules to events that it receives from indexers **206**. Indexers **206** may apply the extraction rules to events in an associated data store **208**. Extraction rules can be applied to all the events in a data store or to a subset of the events that have been filtered based on some criteria (e.g., event time stamp values, etc.). Extraction rules can be used to extract one or more values for a field from events by parsing the portions of machine data in the events and examining the data for one or more patterns of characters, numbers, delimiters, etc., that indicate where the field begins and, optionally, ends.

[0276] FIG. 7A is a diagram of an example scenario where a common customer identifier is found among log data received from three disparate data sources, in accordance with example embodiments. In this example, a user submits an order for merchandise using a vendor’s shopping application program **701** running on the user’s system. In this example, the order was not delivered to the vendor’s server due to a resource exception at the destination server that is detected by the middleware code **702**. The user then sends a message to the customer support server **703** to complain about the order failing to complete. The three systems **701**, **702**, and **703** are disparate systems that do not have a common logging format. The order application **701** sends log data **704** to the data intake and query system in one format, the middleware code **702** sends error log data **705** in a second format, and the support server **703** sends log data **706** in a third format.

[0277] Using the log data received at one or more indexers **206** from the three systems, the vendor can uniquely obtain an insight into user activity, user experience, and system behavior. The search head **210** allows the vendor’s administrator to search the log data from the three systems that one or more indexers **206** are responsible for searching, thereby obtaining correlated information, such as the order number and corresponding customer ID number of the person plac-

ing the order. The system also allows the administrator to see a visualization of related events via a user interface. The administrator can query the search head **210** for customer ID field value matches across the log data from the three systems that are stored at the one or more indexers **206**. The customer ID field value exists in the data gathered from the three systems, but the customer ID field value may be located in different areas of the data given differences in the architecture of the systems. There is a semantic relationship between the customer ID field values generated by the three systems. The search head **210** requests events from the one or more indexers **206** to gather relevant events from the three systems. The search head **210** then applies extraction rules to the events in order to extract field values that it can correlate. The search head may apply a different extraction rule to each set of events from each system when the event format differs among systems. In this example, the user interface can display to the administrator the events corresponding to the common customer ID field values **707**, **708**, and **709**, thereby providing the administrator with insight into a customer’s experience.

[0278] Note that query results can be returned to a client, a search head, or any other system component for further processing. In general, query results may include a set of one or more events, a set of one or more values obtained from the events, a subset of the values, statistics calculated based on the values, a report containing the values, a visualization (e.g., a graph or chart) generated from the values, and the like.

[0279] The search system enables users to run queries against the stored data to retrieve events that meet criteria specified in a query, such as containing certain keywords or having specific values in defined fields. FIG. 7B illustrates the manner in which keyword searches and field searches are processed in accordance with disclosed embodiments.

[0280] If a user inputs a search query into search bar **1401** that includes only keywords (also known as “tokens”), e.g., the keyword “error” or “warning”, the query search engine of the data intake and query system searches for those keywords directly in the event data **722** stored in the raw record data store. Note that while FIG. 7B only illustrates four events, the raw record data store (corresponding to data store **208** in FIG. 2) may contain records for millions of events.

[0281] As disclosed above, an indexer can optionally generate a keyword index to facilitate fast keyword searching for event data. The indexer includes the identified keywords in an index, which associates each stored keyword with reference pointers to events containing that keyword (or to locations within events where that keyword is located, other location identifiers, etc.). When an indexer subsequently receives a keyword-based query, the indexer can access the keyword index to quickly identify events containing the keyword. For example, if the keyword “HTTP” was indexed by the indexer at index time, and the user searches for the keyword “HTTP”, events **713** to **715** will be identified based on the results returned from the keyword index. As noted above, the index contains reference pointers to the events containing the keyword, which allows for efficient retrieval of the relevant events from the raw record data store.

[0282] If a user searches for a keyword that has not been indexed by the indexer, the data intake and query system would nevertheless be able to retrieve the events by search-

ing the event data for the keyword in the raw record data store directly as shown in FIG. 7B. For example, if a user searches for the keyword “frank”, and the name “frank” has not been indexed at index time, the DATA INTAKE AND QUERY system will search the event data directly and return the first event 713. Note that whether the keyword has been indexed at index time or not, in both cases the raw data with the events 712 is accessed from the raw data record store to service the keyword search. In the case where the keyword has been indexed, the index will contain a reference pointer that will allow for a more efficient retrieval of the event data from the data store. If the keyword has not been indexed, the search engine will need to search through all the records in the data store to service the search.

[0283] In most cases, however, in addition to keywords, a user’s search will also include fields. The term “field” refers to a location in the event data containing one or more values for a specific data item. Often, a field is a value with a fixed, delimited position on a line, or a name and value pair, where there is a single value to each field name. A field can also be multivalued, that is, it can appear more than once in an event and have a different value for each appearance, e.g., email address fields. Fields are searchable by the field name or field name-value pairs. Some examples of fields are “clientip” for IP addresses accessing a web server, or the “From” and “To” fields in email addresses.

[0284] By way of further example, consider the search, “status=404”. This search query finds events with “status” fields that have a value of “404.” When the search is run, the search engine does not look for events with any other “status” value. It also does not look for events containing other fields that share “404” as a value. As a result, the search returns a set of results that are more focused than if “404” had been used in the search string as part of a keyword search. Note also that fields can appear in events as “key=value” pairs such as “user_name=Bob.” But in most cases, field values appear in fixed, delimited positions without identifying keys. For example, the data store may contain events where the “user_name” value always appears by itself after the timestamp as illustrated by the following string: “November 15 09:33:22 johnmedlock.”

[0285] The data intake and query system advantageously allows for search time field extraction. In other words, fields can be extracted from the event data at search time using late-binding schema as opposed to at data ingestion time, which was a major limitation of the prior art systems.

[0286] In response to receiving the search query, search head 210 uses extraction rules to extract values for the fields associated with a field or fields in the event data being searched. The search head 210 obtains extraction rules that specify how to extract a value for certain fields from an event. Extraction rules can comprise regex rules that specify how to extract values for the relevant fields. In addition to specifying how to extract field values, the extraction rules may also include instructions for deriving a field value by performing a function on a character string or value retrieved by the extraction rule. For example, a transformation rule may truncate a character string, or convert the character string into a different data format. In some cases, the query itself can specify one or more extraction rules.

[0287] FIG. 7B illustrates the manner in which configuration files may be used to configure custom fields at search time in accordance with the disclosed embodiments. In response to receiving a search query, the data intake and

query system determines if the query references a “field.” For example, a query may request a list of events where the “clientip” field equals “127.0.0.1.” If the query itself does not specify an extraction rule and if the field is not a metadata field, e.g., time, host, source, source type, etc., then in order to determine an extraction rule, the search engine may, in one or more embodiments, need to locate configuration file 712 during the execution of the search as shown in FIG. 7B.

[0288] Configuration file 712 may contain extraction rules for all the various fields that are not metadata fields, e.g., the “clientip” field. The extraction rules may be inserted into the configuration file in a variety of ways. In some embodiments, the extraction rules can comprise regular expression rules that are manually entered in by the user. Regular expressions match patterns of characters in text and are used for extracting custom fields in text.

[0289] In one or more embodiments, as noted above, a field extractor may be configured to automatically generate extraction rules for certain field values in the events when the events are being created, indexed, or stored, or possibly at a later time. In one embodiment, a user may be able to dynamically create custom fields by highlighting portions of a sample event that should be extracted as fields using a graphical user interface. The system would then generate a regular expression that extracts those fields from similar events and store the regular expression as an extraction rule for the associated field in the configuration file 712.

[0290] In some embodiments, the indexers may automatically discover certain custom fields at index time and the regular expressions for those fields will be automatically generated at index time and stored as part of extraction rules in configuration file 712. For example, fields that appear in the event data as “key=value” pairs may be automatically extracted as part of an automatic field discovery process. Note that there may be several other ways of adding field definitions to configuration files in addition to the methods discussed herein.

[0291] The search head 210 can apply the extraction rules derived from configuration file 1402 to event data that it receives from indexers 206. Indexers 206 may apply the extraction rules from the configuration file to events in an associated data store 208. Extraction rules can be applied to all the events in a data store, or to a subset of the events that have been filtered based on some criteria (e.g., event time stamp values, etc.). Extraction rules can be used to extract one or more values for a field from events by parsing the event data and examining the event data for one or more patterns of characters, numbers, delimiters, etc., that indicate where the field begins and, optionally, ends.

[0292] In one more embodiments, the extraction rule in configuration file 712 will also need to define the type or set of events that the rule applies to. Because the raw record data store will contain events from multiple heterogeneous sources, multiple events may contain the same fields in different locations because of discrepancies in the format of the data generated by the various sources. Furthermore, certain events may not contain a particular field at all. For example, event 719 also contains “clientip” field, however, the “clientip” field is in a different format from events 713-715. To address the discrepancies in the format and content of the different types of events, the configuration file will also need to specify the set of events that an extraction rule applies to, e.g., extraction rule 716 specifies a rule for

filtering by the type of event and contains a regular expression for parsing out the field value. Accordingly, each extraction rule will pertain to only a particular type of event. If a particular field, e.g., “clientip” occurs in multiple events, each of those types of events would need its own corresponding extraction rule in the configuration file **712** and each of the extraction rules would comprise a different regular expression to parse out the associated field value. The most common way to categorize events is by source type because events generated by a particular source can have the same format.

[0293] The field extraction rules stored in configuration file **712** perform search-time field extractions. For example, for a query that requests a list of events with source type “access_combined” where the “clientip” field equals “127.0.0.1,” the query search engine would first locate the configuration file **712** to retrieve extraction rule **716** that would allow it to extract values associated with the “clientip” field from the event data **720** “where the source type is “access_combined. After the “clientip” field has been extracted from all the events comprising the “clientip” field where the source type is “access_combined,” the query search engine can then execute the field criteria by performing the compare operation to filter out the events where the “clientip” field equals “127.0.0.1.” In the example shown in FIG. **7B**, events **713-715** would be returned in response to the user query. In this manner, the search engine can service queries containing field criteria in addition to queries containing keyword criteria (as explained above).

[0294] The configuration file can be created during indexing. It may either be manually created by the user or automatically generated with certain predetermined field extraction rules. As discussed above, the events may be distributed across several indexers, wherein each indexer may be responsible for storing and searching a subset of the events contained in a corresponding data store. In a distributed indexer system, each indexer would need to maintain a local copy of the configuration file that is synchronized periodically across the various indexers.

[0295] The ability to add schema to the configuration file at search time results in increased efficiency. A user can create new fields at search time and simply add field definitions to the configuration file. As a user learns more about the data in the events, the user can continue to refine the late-binding schema by adding new fields, deleting fields, or modifying the field extraction rules in the configuration file for use the next time the schema is used by the system. Because the data intake and query system maintains the underlying raw data and uses late-binding schema for searching the raw data, it enables a user to continue investigating and learn valuable insights about the raw data long after data ingestion time.

[0296] The ability to add multiple field definitions to the configuration file at search time also results in increased flexibility. For example, multiple field definitions can be added to the configuration file to capture the same field across events generated by different source types. This allows the data intake and query system to search and correlate data across heterogeneous sources flexibly and efficiently.

[0297] Further, by providing the field definitions for the queried fields at search time, the configuration file **712** allows the record data store **712** to be field searchable. In other words, the raw record data store **712** can be searched

using keywords as well as fields, wherein the fields are searchable name/value pairings that distinguish one event from another and can be defined in configuration file **1402** using extraction rules. In comparison to a search containing field names, a keyword search does not need the configuration file and can search the event data directly as shown in FIG. **7B**.

[0298] It should also be noted that any events filtered out by performing a search-time field extraction using a configuration file can be further processed by directing the results of the filtering step to a processing step using a pipelined search language. Using the prior example, a user could pipeline the results of the compare step to an aggregate function by asking the query search engine to count the number of events where the “clientip” field equals “127.0.0.1.”

2.11. Example Search Screen

[0299] FIG. **8A** is an interface diagram of an example user interface for a search screen **800**, in accordance with example embodiments. Search screen **800** includes a search bar **802** that accepts user input in the form of a search string. It also includes a time range picker **812** that enables the user to specify a time range for the search. For historical searches (e.g., searches based on a particular historical time range), the user can select a specific time range, or alternatively a relative time range, such as “today,” “yesterday” or “last week.” For real-time searches (e.g., searches whose results are based on data received in real-time), the user can select the size of a preceding time window to search for real-time events. Search screen **800** also initially displays a “data summary” dialog as is illustrated in FIG. **8B** that enables the user to select different sources for the events, such as by selecting specific hosts and log files.

[0300] After the search is executed, the search screen **800** in FIG. **8A** can display the results through search results tabs **804**, wherein search results tabs **804** includes: an “events tab” that displays various information about events returned by the search; a “statistics tab” that displays statistics about the search results; and a “visualization tab” that displays various visualizations of the search results. The events tab illustrated in FIG. **8A** displays a timeline graph **805** that graphically illustrates the number of events that occurred in one-hour intervals over the selected time range. The events tab also displays an events list **808** that enables a user to view the machine data in each of the returned events.

[0301] The events tab additionally displays a sidebar that is an interactive field picker **806**. The field picker **806** may be displayed to a user in response to the search being executed and allows the user to further analyze the search results based on the fields in the events of the search results. The field picker **806** includes field names that reference fields present in the events in the search results. The field picker may display any Selected Fields **820** that a user has pre-selected for display (e.g., host, source, sourcetype) and may also display any Interesting Fields **822** that the system determines may be interesting to the user based on pre-specified criteria (e.g., action, bytes, categoryid, clientip, date_hour, date_mday, date_minute, etc.). The field picker also provides an option to display field names for all the fields present in the events of the search results using the All Fields control **824**.

[0302] Each field name in the field picker **806** has a value type identifier to the left of the field name, such as value type

identifier **826**. A value type identifier identifies the type of value for the respective field, such as an “a” for fields that include literal values or a “#” for fields that include numerical values.

[0303] Each field name in the field picker also has a unique value count to the right of the field name, such as unique value count **828**. The unique value count indicates the number of unique values for the respective field in the events of the search results.

[0304] Each field name is selectable to view the events in the search results that have the field referenced by that field name. For example, a user can select the “host” field name, and the events shown in the events list **808** will be updated with events in the search results that have the field that is reference by the field name “host.”

2.12. Data Models

[0305] A data model is a hierarchically structured search-time mapping of semantic knowledge about one or more datasets. It encodes the domain knowledge used to build a variety of specialized searches of those datasets. Those searches, in turn, can be used to generate reports.

[0306] A data model is composed of one or more “objects” (or “data model objects”) that define or otherwise correspond to a specific set of data. An object is defined by constraints and attributes. An object’s constraints are search criteria that define the set of events to be operated on by running a search having that search criteria at the time the data model is selected. An object’s attributes are the set of fields to be exposed for operating on that set of events generated by the search criteria.

[0307] Objects in data models can be arranged hierarchically in parent/child relationships. Each child object represents a subset of the dataset covered by its parent object. The top-level objects in data models are collectively referred to as “root objects.”

[0308] Child objects have inheritance. Child objects inherit constraints and attributes from their parent objects and may have additional constraints and attributes of their own. Child objects provide a way of filtering events from parent objects. Because a child object may provide an additional constraint in addition to the constraints it has inherited from its parent object, the dataset it represents may be a subset of the dataset that its parent represents. For example, a first data model object may define a broad set of data pertaining to e-mail activity generally, and another data model object may define specific datasets within the broad dataset, such as a subset of the e-mail data pertaining specifically to e-mails sent. For example, a user can simply select an “e-mail activity” data model object to access a dataset relating to e-mails generally (e.g., sent or received), or select an “e-mails sent” data model object (or data sub-model object) to access a dataset relating to e-mails sent.

[0309] Because a data model object is defined by its constraints (e.g., a set of search criteria) and attributes (e.g., a set of fields), a data model object can be used to quickly search data to identify a set of events and to identify a set of fields to be associated with the set of events. For example, an “e-mails sent” data model object may specify a search for events relating to e-mails that have been sent, and specify a set of fields that are associated with the events. Thus, a user can retrieve and use the “e-mails sent” data model object to quickly search source data for events relating to sent e-mails,

and may be provided with a listing of the set of fields relevant to the events in a user interface screen.

[0310] Examples of data models can include electronic mail, authentication, databases, intrusion detection, malware, application state, alerts, compute inventory, network sessions, network traffic, performance, audits, updates, vulnerabilities, etc. Data models and their objects can be designed by knowledge managers in an organization, and they can enable downstream users to quickly focus on a specific set of data. A user iteratively applies a model development tool (not shown in FIG. **8A**) to prepare a query that defines a subset of events and assigns an object name to that subset. A child subset is created by further limiting a query that generated a parent subset.

[0311] Data definitions in associated schemas can be taken from the common information model (CIM) or can be devised for a particular schema and optionally added to the CIM. Child objects inherit fields from parents and can include fields not present in parents. A model developer can select fewer extraction rules than are available for the sources returned by the query that defines events belonging to a model. Selecting a limited set of extraction rules can be a tool for simplifying and focusing the data model, while allowing a user flexibility to explore the data subset. Development of a data model is further explained in U.S. Pat. Nos. 8,788,525 and 8,788,526, both entitled “DATA MODEL FOR MACHINE DATA FOR SEMANTIC SEARCH”, both issued on 22 Jul. 2014, U.S. Pat. No. 8,983,994, entitled “GENERATION OF A DATA MODEL FOR SEARCHING MACHINE DATA”, issued on 17 Mar. 2015, U.S. Pat. No. 9,128,980, entitled “GENERATION OF A DATA MODEL APPLIED TO QUERIES”, issued on 8 Sep. 2015, and U.S. Pat. No. 9,589,012, entitled “GENERATION OF A DATA MODEL APPLIED TO OBJECT QUERIES”, issued on 7 Mar. 2017, each of which is hereby incorporated by reference in its entirety for all purposes.

[0312] A data model can also include reports. One or more report formats can be associated with a particular data model and be made available to run against the data model. A user can use child objects to design reports with object datasets that already have extraneous data pre-filtered out. In some embodiments, the data intake and query system **108** provides the user with the ability to produce reports (e.g., a table, chart, visualization, etc.) without having to enter SPL, SQL, or other query language terms into a search screen. Data models are used as the basis for the search feature.

[0313] Data models may be selected in a report generation interface. The report generator supports drag-and-drop organization of fields to be summarized in a report. When a model is selected, the fields with available extraction rules are made available for use in the report. The user may refine and/or filter search results to produce more precise reports. The user may select some fields for organizing the report and select other fields for providing detail according to the report organization. For example, “region” and “salesperson” are fields used for organizing the report and sales data can be summarized (subtotaled and totaled) within this organization. The report generator allows the user to specify one or more fields within events and apply statistical analysis on values extracted from the specified one or more fields. The report generator may aggregate search results across sets of events and generate statistics based on aggregated search results. Building reports using the report generation interface is further explained in U.S. patent application Ser. No.

14/503,335, entitled "GENERATING REPORTS FROM UNSTRUCTURED DATA", filed on 30 Sep. 2014, and which is hereby incorporated by reference in its entirety for all purposes. Data visualizations also can be generated in a variety of formats, by reference to the data model. Reports, data visualizations, and data model objects can be saved and associated with the data model for future use. The data model object may be used to perform searches of other data.

[0314] FIGS. 9-15 are interface diagrams of example report generation user interfaces, in accordance with example embodiments. The report generation process may be driven by a predefined data model object, such as a data model object defined and/or saved via a reporting application or a data model object obtained from another source. A user can load a saved data model object using a report editor. For example, the initial search query and fields used to drive the report editor may be obtained from a data model object. The data model object that is used to drive a report generation process may define a search and a set of fields. Upon loading of the data model object, the report generation process may enable a user to use the fields (e.g., the fields defined by the data model object) to define criteria for a report (e.g., filters, split rows/columns, aggregates, etc.) and the search may be used to identify events (e.g., to identify events responsive to the search) used to generate the report. That is, for example, if a data model object is selected to drive a report editor, the graphical user interface of the report editor may enable a user to define reporting criteria for the report using the fields associated with the selected data model object, and the events used to generate the report may be constrained to the events that match, or otherwise satisfy, the search constraints of the selected data model object.

[0315] The selection of a data model object for use in driving a report generation may be facilitated by a data model object selection interface. FIG. 9 illustrates an example interactive data model selection graphical user interface 900 of a report editor that displays a listing of available data models 901. The user may select one of the data models 902.

[0316] FIG. 10 illustrates an example data model object selection graphical user interface 1000 that displays available data objects 1001 for the selected data object model 902. The user may select one of the displayed data model objects 1002 for use in driving the report generation process.

[0317] Once a data model object is selected by the user, a user interface screen 1100 shown in FIG. 11A may display an interactive listing of automatic field identification options 1101 based on the selected data model object. For example, a user may select one of the three illustrated options (e.g., the "All Fields" option 1102, the "Selected Fields" option 1103, or the "Coverage" option (e.g., fields with at least a specified % of coverage) 1104). If the user selects the "All Fields" option 1102, all of the fields identified from the events that were returned in response to an initial search query may be selected. That is, for example, all of the fields of the identified data model object fields may be selected. If the user selects the "Selected Fields" option 1103, only the fields from the fields of the identified data model object fields that are selected by the user may be used. If the user selects the "Coverage" option 1104, only the fields of the identified data model object fields meeting a specified coverage criteria may be selected. A percent coverage may refer to the percentage of events returned by the initial search query that a given field appears in. Thus, for example, if an object

dataset includes 10,000 events returned in response to an initial search query, and the "avg_age" field appears in 854 of those 10,000 events, then the "avg_age" field would have a coverage of 8.54% for that object dataset. If, for example, the user selects the "Coverage" option and specifies a coverage value of 2%, only fields having a coverage value equal to or greater than 2% may be selected. The number of fields corresponding to each selectable option may be displayed in association with each option. For example, "97" displayed next to the "All Fields" option 1102 indicates that 97 fields will be selected if the "All Fields" option is selected. The "3" displayed next to the "Selected Fields" option 1103 indicates that 3 of the 97 fields will be selected if the "Selected Fields" option is selected. The "49" displayed next to the "Coverage" option 1104 indicates that 49 of the 97 fields (e.g., the 49 fields having a coverage of 2% or greater) will be selected if the "Coverage" option is selected. The number of fields corresponding to the "Coverage" option may be dynamically updated based on the specified percent of coverage.

[0318] FIG. 11B illustrates an example graphical user interface screen 1105 displaying the reporting application's "Report Editor" page. The screen may display interactive elements for defining various elements of a report. For example, the page includes a "Filters" element 1106, a "Split Rows" element 1107, a "Split Columns" element 1108, and a "Column Values" element 1109. The page may include a list of search results 1111. In this example, the Split Rows element 1107 is expanded, revealing a listing of fields 1110 that can be used to define additional criteria (e.g., reporting criteria). The listing of fields 1110 may correspond to the selected fields. That is, the listing of fields 1110 may list only the fields previously selected, either automatically and/or manually by a user. FIG. 11C illustrates a formatting dialogue 1112 that may be displayed upon selecting a field from the listing of fields 1110. The dialogue can be used to format the display of the results of the selection (e.g., label the column for the selected field to be displayed as "component").

[0319] FIG. 11D illustrates an example graphical user interface screen 1105 including a table of results 1113 based on the selected criteria including splitting the rows by the "component" field. A column 1114 having an associated count for each component listed in the table may be displayed that indicates an aggregate count of the number of times that the particular field-value pair (e.g., the value in a row for a particular field, such as the value "BucketMover" for the field "component") occurs in the set of events responsive to the initial search query.

[0320] FIG. 12 illustrates an example graphical user interface screen 1200 that allows the user to filter search results and to perform statistical analysis on values extracted from specific fields in the set of events. In this example, the top ten product names ranked by price are selected as a filter 1201 that causes the display of the ten most popular products sorted by price. Each row is displayed by product name and price 1202. This results in each product displayed in a column labeled "product name" along with an associated price in a column labeled "price" 1206. Statistical analysis of other fields in the events associated with the ten most popular products have been specified as column values 1203. A count of the number of successful purchases for each product is displayed in column 1204. These statistics may be produced by filtering the search results by the

product name, finding all occurrences of a successful purchase in a field within the events and generating a total of the number of occurrences. A sum of the total sales is displayed in column **1205**, which is a result of the multiplication of the price and the number of successful purchases for each product.

[**0321**] The reporting application allows the user to create graphical visualizations of the statistics generated for a report. For example, FIG. **13** illustrates an example graphical user interface **1300** that displays a set of components and associated statistics **1301**. The reporting application allows the user to select a visualization of the statistics in a graph (e.g., bar chart, scatter plot, area chart, line chart, pie chart, radial gauge, marker gauge, filler gauge, etc.), where the format of the graph may be selected using the user interface controls **1302** along the left panel of the user interface **1300**. FIG. **14** illustrates an example of a bar chart visualization **1400** of an aspect of the statistical data **1301**. FIG. **15** illustrates a scatter plot visualization **1500** of an aspect of the statistical data **1301**.

2.13. Acceleration Technique

[**0322**] The above-described system provides significant flexibility by enabling a user to analyze massive quantities of minimally-processed data “on the fly” at search time using a late-binding schema, instead of storing pre-specified portions of the data in a database at ingestion time. This flexibility enables a user to see valuable insights, correlate data, and perform subsequent queries to examine interesting aspects of the data that may not have been apparent at ingestion time.

[**0323**] However, performing extraction and analysis operations at search time can involve a large amount of data and require a large number of computational operations, which can cause delays in processing the queries. Advantageously, the data intake and query system also employs a number of unique acceleration techniques that have been developed to speed up analysis operations performed at search time. These techniques include: (1) performing search operations in parallel across multiple indexers; (2) using a keyword index; (3) using a high performance analytics store; and (4) accelerating the process of generating reports. These novel techniques are described in more detail below.

[**0324**] 2.13.1. Aggregation Technique

[**0325**] To facilitate faster query processing, a query can be structured such that multiple indexers perform the query in parallel, while aggregation of search results from the multiple indexers is performed locally at the search head. For example, FIG. **16** is an example search query received from a client and executed by search peers, in accordance with example embodiments. FIG. **16** illustrates how a search query **1602** received from a client at a search head **210** can split into two phases, including: (1) subtasks **1604** (e.g., data retrieval or simple filtering) that may be performed in parallel by indexers **206** for execution, and (2) a search results aggregation operation **1606** to be executed by the search head when the results are ultimately collected from the indexers.

[**0326**] During operation, upon receiving search query **1602**, a search head **210** determines that a portion of the operations involved with the search query may be performed locally by the search head. The search head modifies search query **1602** by substituting “stats” (create aggregate statis-

tics over results sets received from the indexers at the search head) with “prestats” (create statistics by the indexer from local results set) to produce search query **1604**, and then distributes search query **1604** to distributed indexers, which are also referred to as “search peers” or “peer indexers.” Note that search queries may generally specify search criteria or operations to be performed on events that meet the search criteria. Search queries may also specify field names, as well as search criteria for the values in the fields or operations to be performed on the values in the fields. Moreover, the search head may distribute the full search query to the search peers as illustrated in FIG. **6A**, or may alternatively distribute a modified version (e.g., a more restricted version) of the search query to the search peers. In this example, the indexers are responsible for producing the results and sending them to the search head. After the indexers return the results to the search head, the search head aggregates the received results **1606** to form a single search result set. By executing the query in this manner, the system effectively distributes the computational operations across the indexers while minimizing data transfers.

[**0327**] 2.13.2. Keyword Index

[**0328**] As described above with reference to the flow charts in FIG. **5A** and FIG. **6A**, data intake and query system **108** can construct and maintain one or more keyword indices to quickly identify events containing specific keywords. This technique can greatly speed up the processing of queries involving specific keywords. As mentioned above, to build a keyword index, an indexer first identifies a set of keywords. Then, the indexer includes the identified keywords in an index, which associates each stored keyword with references to events containing that keyword, or to locations within events where that keyword is located. When an indexer subsequently receives a keyword-based query, the indexer can access the keyword index to quickly identify events containing the keyword.

[**0329**] 2.13.3. High Performance Analytics Store

[**0330**] To speed up certain types of queries, some embodiments of system **108** create a high performance analytics store, which is referred to as a “summarization table,” that contains entries for specific field-value pairs. Each of these entries keeps track of instances of a specific value in a specific field in the events and includes references to events containing the specific value in the specific field. For example, an example entry in a summarization table can keep track of occurrences of the value “94107” in a “ZIP code” field of a set of events and the entry includes references to all of the events that contain the value “94107” in the ZIP code field. This optimization technique enables the system to quickly process queries that seek to determine how many events have a particular value for a particular field. To this end, the system can examine the entry in the summarization table to count instances of the specific value in the field without having to go through the individual events or perform data extractions at search time. Also, if the system needs to process all events that have a specific field-value combination, the system can use the references in the summarization table entry to directly access the events to extract further information without having to search all of the events to find the specific field-value combination at search time.

[**0331**] In some embodiments, the system maintains a separate summarization table for each of the above-described time-specific buckets that stores events for a specific

time range. A bucket-specific summarization table includes entries for specific field-value combinations that occur in events in the specific bucket. Alternatively, the system can maintain a separate summarization table for each indexer. The indexer-specific summarization table includes entries for the events in a data store that are managed by the specific indexer. Indexer-specific summarization tables may also be bucket-specific.

[0332] The summarization table can be populated by running a periodic query that scans a set of events to find instances of a specific field-value combination, or alternatively instances of all field-value combinations for a specific field. A periodic query can be initiated by a user, or can be scheduled to occur automatically at specific time intervals. A periodic query can also be automatically launched in response to a query that asks for a specific field-value combination.

[0333] In some cases, when the summarization tables may not cover all of the events that are relevant to a query, the system can use the summarization tables to obtain partial results for the events that are covered by summarization tables, but may also have to search through other events that are not covered by the summarization tables to produce additional results. These additional results can then be combined with the partial results to produce a final set of results for the query. The summarization table and associated techniques are described in more detail in U.S. Pat. No. 8,682,925, entitled “DISTRIBUTED HIGH PERFORMANCE ANALYTICS STORE”, issued on 25 Mar. 2014, U.S. Pat. No. 9,128,985, entitled “SUPPLEMENTING A HIGH PERFORMANCE ANALYTICS STORE WITH EVALUATION OF INDIVIDUAL EVENTS TO RESPOND TO AN EVENT QUERY”, issued on 8 Sep. 2015, and U.S. patent application Ser. No. 14/815,973, entitled “GENERATING AND STORING SUMMARIZATION TABLES FOR SETS OF SEARCHABLE EVENTS”, filed on 1 Aug. 2015, each of which is hereby incorporated by reference in its entirety for all purposes.

[0334] To speed up certain types of queries, e.g., frequently encountered queries or computationally intensive queries, some embodiments of system 108 create a high performance analytics store, which is referred to as a “summarization table,” (also referred to as a “lexicon” or “inverted index”) that contains entries for specific field-value pairs. Each of these entries keeps track of instances of a specific value in a specific field in the event data and includes references to events containing the specific value in the specific field. For example, an example entry in an inverted index can keep track of occurrences of the value “94107” in a “ZIP code” field of a set of events and the entry includes references to all of the events that contain the value “94107” in the ZIP code field. Creating the inverted index data structure avoids needing to incur the computational overhead each time a statistical query needs to be run on a frequently encountered field-value pair. In order to expedite queries, in most embodiments, the search engine will employ the inverted index separate from the raw record data store to generate responses to the received queries.

[0335] Note that the term “summarization table” or “inverted index” as used herein is a data structure that may be generated by an indexer that includes at least field names and field values that have been extracted and/or indexed from event records. An inverted index may also include reference values that point to the location(s) in the field

searchable data store where the event records that include the field may be found. Also, an inverted index may be stored using well-known compression techniques to reduce its storage size.

[0336] Further, note that the term “reference value” (also referred to as a “posting value”) as used herein is a value that references the location of a source record in the field searchable data store. In some embodiments, the reference value may include additional information about each record, such as timestamps, record size, meta-data, or the like. Each reference value may be a unique identifier which may be used to access the event data directly in the field searchable data store. In some embodiments, the reference values may be ordered based on each event record’s timestamp. For example, if numbers are used as identifiers, they may be sorted so event records having a later timestamp always have a lower valued identifier than event records with an earlier timestamp, or vice-versa. Reference values are often included in inverted indexes for retrieving and/or identifying event records.

[0337] In one or more embodiments, an inverted index is generated in response to a user-initiated collection query. The term “collection query” as used herein refers to queries that include commands that generate summarization information and inverted indexes (or summarization tables) from event records stored in the field searchable data store.

[0338] Note that a collection query is a special type of query that can be user-generated and is used to create an inverted index. A collection query is not the same as a query that is used to call up or invoke a pre-existing inverted index. In one or more embodiment, a query can comprise an initial step that calls up a pre-generated inverted index on which further filtering and processing can be performed. For example, referring back to FIG. 13, a set of events generated at block 1320 by either using a “collection” query to create a new inverted index or by calling up a pre-generated inverted index. A query with several pipelined steps will start with a pre-generated index to accelerate the query.

[0339] FIG. 7C illustrates the manner in which an inverted index is created and used in accordance with the disclosed embodiments. As shown in FIG. 7C, an inverted index 722 can be created in response to a user-initiated collection query using the event data 723 stored in the raw record data store. For example, a non-limiting example of a collection query may include “collect clientip=127.0.0.1” which may result in an inverted index 722 being generated from the event data 723 as shown in FIG. 7C. Each entry in inverted index 722 includes an event reference value that references the location of a source record in the field searchable data store. The reference value may be used to access the original event record directly from the field searchable data store.

[0340] In one or more embodiments, if one or more of the queries is a collection query, the responsive indexers may generate summarization information based on the fields of the event records located in the field searchable data store. In at least one of the various embodiments, one or more of the fields used in the summarization information may be listed in the collection query and/or they may be determined based on terms included in the collection query. For example, a collection query may include an explicit list of fields to summarize. Or, in at least one of the various embodiments, a collection query may include terms or expressions that explicitly define the fields, e.g., using regex rules. In FIG. 7C, prior to running the collection query that

generates the inverted index 722, the field name “clientip” may need to be defined in a configuration file by specifying the “access_combined” source type and a regular expression rule to parse out the client IP address. Alternatively, the collection query may contain an explicit definition for the field name “clientip” which may obviate the need to reference the configuration file at search time.

[0341] In one or more embodiments, collection queries may be saved and scheduled to run periodically. These scheduled collection queries may periodically update the summarization information corresponding to the query. For example, if the collection query that generates inverted index 722 is scheduled to run periodically, one or more indexers would periodically search through the relevant buckets to update inverted index 722 with event data for any new events with the “clientip” value of “127.0.0.1.”

[0342] In some embodiments, the inverted indexes that include fields, values, and reference value (e.g., inverted index 722) for event records may be included in the summarization information provided to the user. In other embodiments, a user may not be interested in specific fields and values contained in the inverted index, but may need to perform a statistical query on the data in the inverted index. For example, referencing the example of FIG. 7C rather than viewing the fields within summarization table 722, a user may want to generate a count of all client requests from IP address “127.0.0.1.” In this case, the search engine would simply return a result of “4” rather than including details about the inverted index 722 in the information provided to the user.

[0343] The pipelined search language, e.g., SPL of the SPLUNK® ENTERPRISE system can be used to pipe the contents of an inverted index to a statistical query using the “stats” command for example. A “stats” query refers to queries that generate result sets that may produce aggregate and statistical results from event records, e.g., average, mean, max, min, rms, etc. Where sufficient information is available in an inverted index, a “stats” query may generate their result sets rapidly from the summarization information available in the inverted index rather than directly scanning event records. For example, the contents of inverted index 722 can be pipelined to a stats query, e.g., a “count” function that counts the number of entries in the inverted index and returns a value of “4.” In this way, inverted indexes may enable various stats queries to be performed absent scanning or search the event records. Accordingly, this optimization technique enables the system to quickly process queries that seek to determine how many events have a particular value for a particular field. To this end, the system can examine the entry in the inverted index to count instances of the specific value in the field without having to go through the individual events or perform data extractions at search time.

[0344] In some embodiments, the system maintains a separate inverted index for each of the above-described time-specific buckets that stores events for a specific time range. A bucket-specific inverted index includes entries for specific field-value combinations that occur in events in the specific bucket. Alternatively, the system can maintain a separate inverted index for each indexer. The indexer-specific inverted index includes entries for the events in a data store that are managed by the specific indexer. Indexer-specific inverted indexes may also be bucket-specific. In at least one or more embodiments, if one or more of the queries is a stats query, each indexer may generate a partial result set

from previously generated summarization information. The partial result sets may be returned to the search head that received the query and combined into a single result set for the query

[0345] As mentioned above, the inverted index can be populated by running a periodic query that scans a set of events to find instances of a specific field-value combination, or alternatively instances of all field-value combinations for a specific field. A periodic query can be initiated by a user, or can be scheduled to occur automatically at specific time intervals. A periodic query can also be automatically launched in response to a query that asks for a specific field-value combination. In some embodiments, if summarization information is absent from an indexer that includes responsive event records, further actions may be taken, such as, the summarization information may be generated on the fly, warnings may be provided the user, the collection query operation may be halted, the absence of summarization information may be ignored, or the like, or combination thereof.

[0346] In one or more embodiments, an inverted index may be set up to update continually. For example, the query may ask for the inverted index to update its result periodically, e.g., every hour. In such instances, the inverted index may be a dynamic data structure that is regularly updated to include information regarding incoming events.

[0347] In some cases, e.g., where a query is executed before an inverted index updates, when the inverted index may not cover all of the events that are relevant to a query, the system can use the inverted index to obtain partial results for the events that are covered by inverted index, but may also have to search through other events that are not covered by the inverted index to produce additional results on the fly. In other words, an indexer would need to search through event data on the data store to supplement the partial results. These additional results can then be combined with the partial results to produce a final set of results for the query. Note that in typical instances where an inverted index is not completely up to date, the number of events that an indexer would need to search through to supplement the results from the inverted index would be relatively small. In other words, the search to get the most recent results can be quick and efficient because only a small number of event records will be searched through to supplement the information from the inverted index. The inverted index and associated techniques are described in more detail in U.S. Pat. No. 8,682,925, entitled “DISTRIBUTED HIGH PERFORMANCE ANALYTICS STORE”, issued on 25 Mar. 2014, U.S. Pat. No. 9,128,985, entitled “SUPPLEMENTING A HIGH PERFORMANCE ANALYTICS STORE WITH EVALUATION OF INDIVIDUAL EVENTS TO RESPOND TO AN EVENT QUERY”, filed on 31 Jan. 2014, and U.S. patent application Ser. No. 14/815,973, entitled “STORAGE MEDIUM AND CONTROL DEVICE”, filed on 21 Feb. 2014, each of which is hereby incorporated by reference in its entirety.

[0348] 2.13.3.1 EXTRACTING EVENT DATA USING POSTING

[0349] In one or more embodiments, if the system needs to process all events that have a specific field-value combination, the system can use the references in the inverted index entry to directly access the events to extract further information without having to search all of the events to find the specific field-value combination at search time. In other

words, the system can use the reference values to locate the associated event data in the field searchable data store and extract further information from those events, e.g., extract further field values from the events for purposes of filtering or processing or both.

[0350] The information extracted from the event data using the reference values can be directed for further filtering or processing in a query using the pipeline search language. The pipelined search language will, in one embodiment, include syntax that can direct the initial filtering step in a query to an inverted index. In one embodiment, a user would include syntax in the query that explicitly directs the initial searching or filtering step to the inverted index.

[0351] Referencing the example in FIG. 15, if the user determines that she needs the user id fields associated with the client requests from IP address "127.0.0.1," instead of incurring the computational overhead of performing a brand new search or re-generating the inverted index with an additional field, the user can generate a query that explicitly directs or pipes the contents of the already generated inverted index 1502 to another filtering step requesting the user ids for the entries in inverted index 1502 where the server response time is greater than "0.0900" microseconds. The search engine would use the reference values stored in inverted index 722 to retrieve the event data from the field searchable data store, filter the results based on the "response time" field values and, further, extract the user id field from the resulting event data to return to the user. In the present instance, the user ids "frank" and "carlos" would be returned to the user from the generated results table 722.

[0352] In one embodiment, the same methodology can be used to pipe the contents of the inverted index to a processing step. In other words, the user is able to use the inverted index to efficiently and quickly perform aggregate functions on field values that were not part of the initially generated inverted index. For example, a user may want to determine an average object size (size of the requested gif) requested by clients from IP address "127.0.0.1." In this case, the search engine would again use the reference values stored in inverted index 722 to retrieve the event data from the field searchable data store and, further, extract the object size field values from the associated events 731, 732, 733 and 734. Once, the corresponding object sizes have been extracted (i.e. 2326, 2900, 2920, and 5000), the average can be computed and returned to the user.

[0353] In one embodiment, instead of explicitly invoking the inverted index in a user-generated query, e.g., by the use of special commands or syntax, the SPLUNK® ENTERPRISE system can be configured to automatically determine if any prior-generated inverted index can be used to expedite a user query. For example, the user's query may request the average object size (size of the requested gif) requested by clients from IP address "127.0.0.1." without any reference to or use of inverted index 722. The search engine, in this case, would automatically determine that an inverted index 722 already exists in the system that could expedite this query. In one embodiment, prior to running any search comprising a field-value pair, for example, a search engine may search through all the existing inverted indexes to determine if a pre-generated inverted index could be used to expedite the search comprising the field-value pair. Accordingly, the search engine would automatically use the pre-generated

inverted index, e.g., index 722 to generate the results without any user-involvement that directs the use of the index.

[0354] Using the reference values in an inverted index to be able to directly access the event data in the field searchable data store and extract further information from the associated event data for further filtering and processing is highly advantageous because it avoids incurring the computation overhead of regenerating the inverted index with additional fields or performing a new search.

[0355] The data intake and query system includes one or more forwarders that receive raw machine data from a variety of input data sources, and one or more indexers that process and store the data in one or more data stores. By distributing events among the indexers and data stores, the indexers can analyze events for a query in parallel. In one or more embodiments, a multiple indexer implementation of the search system would maintain a separate and respective inverted index for each of the above-described time-specific buckets that stores events for a specific time range. A bucket-specific inverted index includes entries for specific field-value combinations that occur in events in the specific bucket. As explained above, a search head would be able to correlate and synthesize data from across the various buckets and indexers.

[0356] This feature advantageously expedites searches because instead of performing a computationally intensive search in a centrally located inverted index that catalogues all the relevant events, an indexer is able to directly search an inverted index stored in a bucket associated with the time-range specified in the query. This allows the search to be performed in parallel across the various indexers. Further, if the query requests further filtering or processing to be conducted on the event data referenced by the locally stored bucket-specific inverted index, the indexer is able to simply access the event records stored in the associated bucket for further filtering and processing instead of needing to access a central repository of event records, which would dramatically add to the computational overhead.

[0357] In one embodiment, there may be multiple buckets associated with the time-range specified in a query. If the query is directed to an inverted index, or if the search engine automatically determines that using an inverted index would expedite the processing of the query, the indexers will search through each of the inverted indexes associated with the buckets for the specified time-range. This feature allows the High Performance Analytics Store to be scaled easily.

[0358] In certain instances, where a query is executed before a bucket-specific inverted index updates, when the bucket-specific inverted index may not cover all of the events that are relevant to a query, the system can use the bucket-specific inverted index to obtain partial results for the events that are covered by bucket-specific inverted index, but may also have to search through the event data in the bucket associated with the bucket-specific inverted index to produce additional results on the fly. In other words, an indexer would need to search through event data stored in the bucket (that was not yet processed by the indexer for the corresponding inverted index) to supplement the partial results from the bucket-specific inverted index.

[0359] FIG. 7D presents a flowchart illustrating how an inverted index in a pipelined search query can be used to determine a set of event data that can be further limited by filtering or processing in accordance with the disclosed embodiments.

[0360] At block 742, a query is received by a data intake and query system. In some embodiments, the query can be received as a user generated query entered into into search bar of a graphical user search interface. The search interface also includes a time range control element that enables specification of a time range for the query.

[0361] At block 744, an inverted index is retrieved. Note, that the inverted index can be retrieved in response to an explicit user search command inputted as part of the user generated query. Alternatively, the search engine can be configured to automatically use an inverted index if it determines that using the inverted index would expedite the servicing of the user generated query. Each of the entries in an inverted index keeps track of instances of a specific value in a specific field in the event data and includes references to events containing the specific value in the specific field. In order to expedite queries, in most embodiments, the search engine will employ the inverted index separate from the raw record data store to generate responses to the received queries.

[0362] At block 746, the query engine determines if the query contains further filtering and processing steps. If the query contains no further commands, then, in one embodiment, summarization information can be provided to the user at block 754.

[0363] If, however, the query does contain further filtering and processing commands, then at block 750, the query engine determines if the commands relate to further filtering or processing of the data extracted as part of the inverted index or whether the commands are directed to using the inverted index as an initial filtering step to further filter and process event data referenced by the entries in the inverted index. If the query can be completed using data already in the generated inverted index, then the further filtering or processing steps, e.g., a “count” number of records function, “average” number of records per hour etc. are performed and the results are provided to the user at block 752.

[0364] If, however, the query references fields that are not extracted in the inverted index, then the indexers will access event data pointed to by the reference values in the inverted index to retrieve any further information required at block 756. Subsequently, any further filtering or processing steps are performed on the fields extracted directly from the event data and the results are provided to the user at step 758.

[0365] 2.13.4. Accelerating Report Generation

[0366] In some embodiments, a data server system such as the data intake and query system can accelerate the process of periodically generating updated reports based on query results. To accelerate this process, a summarization engine automatically examines the query to determine whether generation of updated reports can be accelerated by creating intermediate summaries. If reports can be accelerated, the summarization engine periodically generates a summary covering data obtained during a latest non-overlapping time period. For example, where the query seeks events meeting a specified criteria, a summary for the time period includes only events within the time period that meet the specified criteria. Similarly, if the query seeks statistics calculated from the events, such as the number of events that match the specified criteria, then the summary for the time period includes the number of events in the period that match the specified criteria.

[0367] In addition to the creation of the summaries, the summarization engine schedules the periodic updating of the

report associated with the query. During each scheduled report update, the query engine determines whether intermediate summaries have been generated covering portions of the time period covered by the report update. If so, then the report is generated based on the information contained in the summaries. Also, if additional event data has been received and has not yet been summarized, and is required to generate the complete report, the query can be run on these additional events. Then, the results returned by this query on the additional events, along with the partial results obtained from the intermediate summaries, can be combined to generate the updated report. This process is repeated each time the report is updated. Alternatively, if the system stores events in buckets covering specific time ranges, then the summaries can be generated on a bucket-by-bucket basis. Note that producing intermediate summaries can save the work involved in re-running the query for previous time periods, so advantageously only the newer events needs to be processed while generating an updated report. These report acceleration techniques are described in more detail in U.S. Pat. No. 8,589,403, entitled “COMPRESSED JOURNALING IN EVENT TRACKING FILES FOR METADATA RECOVERY AND REPLICATION”, issued on 19 Nov. 2013, U.S. Pat. No. 8,412,696, entitled “REAL TIME SEARCHING AND REPORTING”, issued on 2 Apr. 2011, and U.S. Pat. Nos. 8,589,375 and 8,589,432, both also entitled “REAL TIME SEARCHING AND REPORTING”, both issued on 19 Nov. 2013, each of which is hereby incorporated by reference in its entirety for all purposes.

2.14. Security Features

[0368] The data intake and query system provides various schemas, dashboards, and visualizations that simplify developers’ tasks to create applications with additional capabilities. One such application is the an enterprise security application, such as SPLUNK® ENTERPRISE SECURITY, which performs monitoring and alerting operations and includes analytics to facilitate identifying both known and unknown security threats based on large volumes of data stored by the data intake and query system. The enterprise security application provides the security practitioner with visibility into security-relevant threats found in the enterprise infrastructure by capturing, monitoring, and reporting on data from enterprise security devices, systems, and applications. Through the use of the data intake and query system searching and reporting capabilities, the enterprise security application provides a top-down and bottom-up view of an organization’s security posture.

[0369] The enterprise security application leverages the data intake and query system search-time normalization techniques, saved searches, and correlation searches to provide visibility into security-relevant threats and activity and generate notable events for tracking. The enterprise security application enables the security practitioner to investigate and explore the data to find new or unknown threats that do not follow signature-based patterns.

[0370] Conventional Security Information and Event Management (SIEM) systems lack the infrastructure to effectively store and analyze large volumes of security-related data. Traditional SIEM systems typically use fixed schemas to extract data from pre-defined security-related fields at data ingestion time and store the extracted data in a relational database. This traditional data extraction process (and associated reduction in data size) that occurs at data

ingestion time inevitably hampers future incident investigations that may need original data to determine the root cause of a security issue, or to detect the onset of an impending security threat.

[0371] In contrast, the enterprise security application system stores large volumes of minimally-processed security-related data at ingestion time for later retrieval and analysis at search time when a live security threat is being investigated. To facilitate this data retrieval process, the enterprise security application provides pre-specified schemas for extracting relevant values from the different types of security-related events and enables a user to define such schemas.

[0372] The enterprise security application can process many types of security-related information. In general, this security-related information can include any information that can be used to identify security threats. For example, the security-related information can include network-related information, such as IP addresses, domain names, asset identifiers, network traffic volume, uniform resource locator strings, and source addresses. The process of detecting security threats for network-related information is further described in U.S. Pat. No. 8,826,434, entitled “SECURITY THREAT DETECTION BASED ON INDICATIONS IN BIG DATA OF ACCESS TO NEWLY REGISTERED DOMAINS”, issued on 2 Sep. 2014, U.S. Pat. No. 9,215,240, entitled “INVESTIGATIVE AND DYNAMIC DETECTION OF POTENTIAL SECURITY-THREAT INDICATORS FROM EVENTS IN BIG DATA”, issued on 15 Dec. 2015, U.S. Pat. No. 9,173,801, entitled “GRAPHIC DISPLAY OF SECURITY THREATS BASED ON INDICATIONS OF ACCESS TO NEWLY REGISTERED DOMAINS”, issued on 3 Nov. 2015, U.S. Pat. No. 9,248,068, entitled “SECURITY THREAT DETECTION OF NEWLY REGISTERED DOMAINS”, issued on 2 Feb. 2016, U.S. Pat. No. 9,426,172, entitled “SECURITY THREAT DETECTION USING DOMAIN NAME ACCESSES”, issued on 23 Aug. 2016, and U.S. Pat. No. 9,432,396, entitled “SECURITY THREAT DETECTION USING DOMAIN NAME REGISTRATIONS”, issued on 30 Aug. 2016, each of which is hereby incorporated by reference in its entirety for all purposes. Security-related information can also include malware infection data and system configuration information, as well as access control information, such as login/logout information and access failure notifications. The security-related information can originate from various sources within a data center, such as hosts, virtual machines, storage devices and sensors. The security-related information can also originate from various sources in a network, such as routers, switches, email servers, proxy servers, gateways, firewalls and intrusion-detection systems.

[0373] During operation, the enterprise security application facilitates detecting “notable events” that are likely to indicate a security threat. A notable event represents one or more anomalous incidents, the occurrence of which can be identified based on one or more events (e.g., time stamped portions of raw machine data) fulfilling pre-specified and/or dynamically-determined (e.g., based on machine-learning) criteria defined for that notable event. Examples of notable events include the repeated occurrence of an abnormal spike in network usage over a period of time, a single occurrence of unauthorized access to system, a host communicating with a server on a known threat list, and the like. These

notable events can be detected in a number of ways, such as: (1) a user can notice a correlation in events and can manually identify that a corresponding group of one or more events amounts to a notable event; or (2) a user can define a “correlation search” specifying criteria for a notable event, and every time one or more events satisfy the criteria, the application can indicate that the one or more events correspond to a notable event; and the like. A user can alternatively select a pre-defined correlation search provided by the application. Note that correlation searches can be run continuously or at regular intervals (e.g., every hour) to search for notable events. Upon detection, notable events can be stored in a dedicated “notable events index,” which can be subsequently accessed to generate various visualizations containing security-related information. Also, alerts can be generated to notify system operators when important notable events are discovered.

[0374] The enterprise security application provides various visualizations to aid in discovering security threats, such as a “key indicators view” that enables a user to view security metrics, such as counts of different types of notable events. For example, FIG. 17A illustrates an example key indicators view **1700** that comprises a dashboard, which can display a value **1701**, for various security-related metrics, such as malware infections **1702**. It can also display a change in a metric value **1703**, which indicates that the number of malware infections increased by 63 during the preceding interval. Key indicators view **1700** additionally displays a histogram panel **1704** that displays a histogram of notable events organized by urgency values, and a histogram of notable events organized by time intervals. This key indicators view is described in further detail in pending U.S. patent application Ser. No. 13/956,338, entitled “KEY INDICATORS VIEW”, filed on 31 Jul. 2013, and which is hereby incorporated by reference in its entirety for all purposes.

[0375] These visualizations can also include an “incident review dashboard” that enables a user to view and act on “notable events.” These notable events can include: (1) a single event of high importance, such as any activity from a known web attacker; or (2) multiple events that collectively warrant review, such as a large number of authentication failures on a host followed by a successful authentication. For example, FIG. 17B illustrates an example incident review dashboard **1710** that includes a set of incident attribute fields **1711** that, for example, enables a user to specify a time range field **1712** for the displayed events. It also includes a timeline **1713** that graphically illustrates the number of incidents that occurred in time intervals over the selected time range. It additionally displays an events list **1714** that enables a user to view a list of all of the notable events that match the criteria in the incident attributes fields **1711**. To facilitate identifying patterns among the notable events, each notable event can be associated with an urgency value (e.g., low, medium, high, critical), which is indicated in the incident review dashboard. The urgency value for a detected event can be determined based on the severity of the event and the priority of the system component associated with the event.

2.15. Data Center Monitoring

[0376] As mentioned above, the data intake and query platform provides various features that simplify the developers’ task to create various applications. One such application is a virtual machine monitoring application, such as

SPLUNK® APP FOR VMWARE® that provides operational visibility into granular performance metrics, logs, tasks and events, and topology from hosts, virtual machines and virtual centers. It empowers administrators with an accurate real-time picture of the health of the environment, proactively identifying performance and capacity bottlenecks.

[0377] Conventional data-center-monitoring systems lack the infrastructure to effectively store and analyze large volumes of machine-generated data, such as performance information and log data obtained from the data center. In conventional data-center-monitoring systems, machine-generated data is typically pre-processed prior to being stored, for example, by extracting pre-specified data items and storing them in a database to facilitate subsequent retrieval and analysis at search time. However, the rest of the data is not saved and discarded during pre-processing.

[0378] In contrast, the virtual machine monitoring application stores large volumes of minimally processed machine data, such as performance information and log data, at ingestion time for later retrieval and analysis at search time when a live performance issue is being investigated. In addition to data obtained from various log files, this performance-related information can include values for performance metrics obtained through an application programming interface (API) provided as part of the vSphere Hypervisor™ system distributed by VMware, Inc. of Palo Alto, Calif. For example, these performance metrics can include: (1) CPU-related performance metrics; (2) disk-related performance metrics; (3) memory-related performance metrics; (4) network-related performance metrics; (5) energy-usage statistics; (6) data-traffic-related performance metrics; (7) overall system availability performance metrics; (8) cluster-related performance metrics; and (9) virtual machine performance statistics. Such performance metrics are described in U.S. patent application Ser. No. 14/167,316, entitled “CORRELATION FOR USER-SELECTED TIME RANGES OF VALUES FOR PERFORMANCE METRICS OF COMPONENTS IN AN INFORMATION-TECHNOLOGY ENVIRONMENT WITH LOG DATA FROM THAT INFORMATION-TECHNOLOGY ENVIRONMENT”, filed on 29 Jan. 2014, and which is hereby incorporated by reference in its entirety for all purposes.

[0379] To facilitate retrieving information of interest from performance data and log files, the virtual machine monitoring application provides pre-specified schemas for extracting relevant values from different types of performance-related events, and also enables a user to define such schemas.

[0380] The virtual machine monitoring application additionally provides various visualizations to facilitate detecting and diagnosing the root cause of performance problems. For example, one such visualization is a “proactive monitoring tree” that enables a user to easily view and understand relationships among various factors that affect the performance of a hierarchically structured computing system. This proactive monitoring tree enables a user to easily navigate the hierarchy by selectively expanding nodes representing various entities (e.g., virtual centers or computing clusters) to view performance information for lower-level nodes associated with lower-level entities (e.g., virtual machines or host systems). Example node-expansion operations are illustrated in FIG. 17C, wherein nodes 1733 and 1734 are selectively expanded. Note that nodes 1731-1739 can be

displayed using different patterns or colors to represent different performance states, such as a critical state, a warning state, a normal state or an unknown/offline state. The ease of navigation provided by selective expansion in combination with the associated performance-state information enables a user to quickly diagnose the root cause of a performance problem. The proactive monitoring tree is described in further detail in U.S. Pat. No. 9,185,007, entitled “PROACTIVE MONITORING TREE WITH SEVERITY STATE SORTING”, issued on 10 Nov. 2015, and U.S. Pat. No. 9,426,045, also entitled “PROACTIVE MONITORING TREE WITH SEVERITY STATE SORTING”, issued on 23 Aug. 2016, each of which is hereby incorporated by reference in its entirety for all purposes.

[0381] The virtual machine monitoring application also provides a user interface that enables a user to select a specific time range and then view heterogeneous data comprising events, log data, and associated performance metrics for the selected time range. For example, the screen illustrated in FIG. 17D displays a listing of recent “tasks and events” and a listing of recent “log entries” for a selected time range above a performance-metric graph for “average CPU core utilization” for the selected time range. Note that a user is able to operate pull-down menus 1742 to selectively display different performance metric graphs for the selected time range. This enables the user to correlate trends in the performance-metric graph with corresponding event and log data to quickly determine the root cause of a performance problem. This user interface is described in more detail in U.S. patent application Ser. No. 14/167,316, entitled “CORRELATION FOR USER-SELECTED TIME RANGES OF VALUES FOR PERFORMANCE METRICS OF COMPONENTS IN AN INFORMATION-TECHNOLOGY ENVIRONMENT WITH LOG DATA FROM THAT INFORMATION-TECHNOLOGY ENVIRONMENT”, filed on 29 Jan. 2014, and which is hereby incorporated by reference in its entirety for all purposes.

2.16. IT Service Monitoring

[0382] As previously mentioned, the data intake and query platform provides various schemas, dashboards and visualizations that make it easy for developers to create applications to provide additional capabilities. One such application is an IT monitoring application, such as SPLUNK® IT SERVICE INTELLIGENCE™, which performs monitoring and alerting operations. The IT monitoring application also includes analytics to help an analyst diagnose the root cause of performance problems based on large volumes of data stored by the data intake and query system as correlated to the various services an IT organization provides (a service-centric view). This differs significantly from conventional IT monitoring systems that lack the infrastructure to effectively store and analyze large volumes of service-related events. Traditional service monitoring systems typically use fixed schemas to extract data from pre-defined fields at data ingestion time, wherein the extracted data is typically stored in a relational database. This data extraction process and associated reduction in data content that occurs at data ingestion time inevitably hampers future investigations, when all of the original data may be needed to determine the root cause of or contributing factors to a service issue.

[0383] In contrast, an IT monitoring application system stores large volumes of minimally-processed service-related data at ingestion time for later retrieval and analysis at

search time, to perform regular monitoring, or to investigate a service issue. To facilitate this data retrieval process, the IT monitoring application enables a user to define an IT operations infrastructure from the perspective of the services it provides. In this service-centric approach, a service such as corporate e-mail may be defined in terms of the entities employed to provide the service, such as host machines and network devices. Each entity is defined to include information for identifying all of the events that pertains to the entity, whether produced by the entity itself or by another machine, and considering the many various ways the entity may be identified in machine data (such as by a URL, an IP address, or machine name). The service and entity definitions can organize events around a service so that all of the events pertaining to that service can be easily identified. This capability provides a foundation for the implementation of Key Performance Indicators.

[0384] One or more Key Performance Indicators (KPI's) are defined for a service within the IT monitoring application. Each KPI measures an aspect of service performance at a point in time or over a period of time (aspect KPI's). Each KPI is defined by a search query that derives a KPI value from the machine data of events associated with the entities that provide the service. Information in the entity definitions may be used to identify the appropriate events at the time a KPI is defined or whenever a KPI value is being determined. The KPI values derived over time may be stored to build a valuable repository of current and historical performance information for the service, and the repository, itself, may be subject to search query processing. Aggregate KPIs may be defined to provide a measure of service performance calculated from a set of service aspect KPI values; this aggregate may even be taken across defined timeframes and/or across multiple services. A particular service may have an aggregate KPI derived from substantially all of the aspect KPI's of the service to indicate an overall health score for the service.

[0385] The IT monitoring application facilitates the production of meaningful aggregate KPI's through a system of KPI thresholds and state values. Different KPI definitions may produce values in different ranges, and so the same value may mean something very different from one KPI definition to another. To address this, the IT monitoring application implements a translation of individual KPI values to a common domain of "state" values. For example, a KPI range of values may be 1-100, or 50-275, while values in the state domain may be 'critical,' 'warning,' 'normal,' and 'informational'. Thresholds associated with a particular KPI definition determine ranges of values for that KPI that correspond to the various state values. In one case, KPI values 95-100 may be set to correspond to 'critical' in the state domain. KPI values from disparate KPI's can be processed uniformly once they are translated into the common state values using the thresholds. For example, "normal 80% of the time" can be applied across various KPI's. To provide meaningful aggregate KPI's, a weighting value can be assigned to each KPI so that its influence on the calculated aggregate KPI value is increased or decreased relative to the other KPI's.

[0386] One service in an IT environment often impacts, or is impacted by, another service. The IT monitoring application can reflect these dependencies. For example, a dependency relationship between a corporate e-mail service and a centralized authentication service can be reflected by record-

ing an association between their respective service definitions. The recorded associations establish a service dependency topology that informs the data or selection options presented in a GUI, for example. (The service dependency topology is like a "map" showing how services are connected based on their dependencies.) The service topology may itself be depicted in a GUI and may be interactive to allow navigation among related services.

[0387] Entity definitions in the IT monitoring application can include informational fields that can serve as metadata, implied data fields, or attributed data fields for the events identified by other aspects of the entity definition. Entity definitions in the IT monitoring application can also be created and updated by an import of tabular data (as represented in a CSV, another delimited file, or a search query result set). The import may be GUI-mediated or processed using import parameters from a GUI-based import definition process. Entity definitions in the IT monitoring application can also be associated with a service by means of a service definition rule. Processing the rule results in the matching entity definitions being associated with the service definition. The rule can be processed at creation time, and thereafter on a scheduled or on-demand basis. This allows dynamic, rule-based updates to the service definition.

[0388] During operation, the IT monitoring application can recognize notable events that may indicate a service performance problem or other situation of interest. These notable events can be recognized by a "correlation search" specifying trigger criteria for a notable event: every time KPI values satisfy the criteria, the application indicates a notable event. A severity level for the notable event may also be specified. Furthermore, when trigger criteria are satisfied, the correlation search may additionally or alternatively cause a service ticket to be created in an IT service management (ITSM) system, such as a systems available from ServiceNow, Inc., of Santa Clara, Calif.

[0389] SPLUNK® IT SERVICE INTELLIGENCE™ provides various visualizations built on its service-centric organization of events and the KPI values generated and collected. Visualizations can be particularly useful for monitoring or investigating service performance. The IT monitoring application provides a service monitoring interface suitable as the home page for ongoing IT service monitoring. The interface is appropriate for settings such as desktop use or for a wall-mounted display in a network operations center (NOC). The interface may prominently display a services health section with tiles for the aggregate KPI's indicating overall health for defined services and a general KPI section with tiles for KPI's related to individual service aspects. These tiles may display KPI information in a variety of ways, such as by being colored and ordered according to factors like the KPI state value. They also can be interactive and navigate to visualizations of more detailed KPI information.

[0390] The IT monitoring application provides a service-monitoring dashboard visualization based on a user-defined template. The template can include user-selectable widgets of varying types and styles to display KPI information. The content and the appearance of widgets can respond dynamically to changing KPI information. The KPI widgets can appear in conjunction with a background image, user drawing objects, or other visual elements, that depict the IT operations environment, for example. The KPI widgets or

other GUI elements can be interactive so as to provide navigation to visualizations of more detailed KPI information.

[0391] The IT monitoring application provides a visualization showing detailed time-series information for multiple KPI's in parallel graph lanes. The length of each lane can correspond to a uniform time range, while the width of each lane may be automatically adjusted to fit the displayed KPI data. Data within each lane may be displayed in a user selectable style, such as a line, area, or bar chart. During operation a user may select a position in the time range of the graph lanes to activate lane inspection at that point in time. Lane inspection may display an indicator for the selected time across the graph lanes and display the KPI value associated with that point in time for each of the graph lanes. The visualization may also provide navigation to an interface for defining a correlation search, using information from the visualization to pre-populate the definition.

[0392] The IT monitoring application provides a visualization for incident review showing detailed information for notable events. The incident review visualization may also show summary information for the notable events over a time frame, such as an indication of the number of notable events at each of a number of severity levels. The severity level display may be presented as a rainbow chart with the warmest color associated with the highest severity classification. The incident review visualization may also show summary information for the notable events over a time frame, such as the number of notable events occurring within segments of the time frame. The incident review visualization may display a list of notable events within the time frame ordered by any number of factors, such as time or severity. The selection of a particular notable event from the list may display detailed information about that notable event, including an identification of the correlation search that generated the notable event.

[0393] The IT monitoring application provides pre-specified schemas for extracting relevant values from the different types of service-related events. It also enables a user to define such schemas.

3.0 User Journeys

[0394] As described above, machine data can be ingested, for example by the data intake and query system **108**, and events produced based on the machine data. The events can be utilized to provide insight into complex computing systems. For example, events can be accessibly maintained in the data stores, and queries identifying a set of data and a manner of processing the data can be executed. In this way, the machine data can be investigated (e.g., poked) via differing queries, updated field definitions, and so on, to identify useful information for requesting users.

[0395] As an example of machine data in disparate computing systems may generate data in response to events, interactions, triggers, and so on. For example, a computing system may record network access events (e.g., user account logins to a computing system), user events (e.g., a computing system may monitor user activity or user behavior), service related events (e.g., as described above with respect to Section 2.16), and so on. In some cases, the disparate computing systems can record user interactions with the computing systems. For example, the machine data may include information indicative of a particular user interacting with a computing system, along with further information

describing the interaction. Further interaction with one computing system can trigger the computing system to interact with another computing system, which may generate machine data in response.

[0396] These disparate computing systems may therefore generate machine data that describes multitudes of touchpoints associated with a respective entity (e.g., a user, an object, a computing system, and so on). In this specification, a touchpoint can refer to any interaction of an entity with a computing system, or any interaction of an entity that is recorded by a computing system. For example, the entity may include a user, and a touchpoint may include the user accessing his/her user account on a particular computing system. The particular computing system, which may be a domain controller or active directory server, may generate machine data associated with the user interaction.

[0397] A second touch point may include the user account performing an action on a user device (e.g., a laptop, computer, tablet), such as causing a download of information to the user device or accessing a virtual private network (VPN). The user device may generate data associated with this second touch point. Additionally, a call received at a call center from an entity may represent a third touch point. For example, a computing system recording received calls may generate machine data in response to the call from the entity.

[0398] A combination of these touchpoints may, as an example, provide useful information related to interactions with one or more computing systems. With respect to the example of users accessing their respective user accounts, additional touchpoints may include particular types of interactions the user accounts perform, along with a touchpoint specifying that the users logged out of their respective user accounts. In this way, the touchpoints may help form a picture of a particular user's utilization of an accessed user account or interaction with various computer systems associated with the user account. For example, a time at which the particular user accessed his/her user account, along with a location from which the access occurred, can be identified from events. Similarly, the system can identify whether the particular user performed particular types of interactions, and then identify a time at which the particular user ceased accessing his/her user account.

[0399] Thus, users, or other entities, may interact with disparate computing systems as part of an ongoing process, or journey. Being able to analyze events describing these interactions, and stitching them together to generate a digestible representation of each user's journey may be beneficial to understand these interactions. For example, stitching (e.g., aggregating) events together can provide insights into specific paths typically taken by users to complete a journey. As an example, a journey may be related to processing of an application, and aggregating events may inform all the interactions (e.g., different paths) that different users have prior to their respective applications being complete. These insights may help improve future computer interactions, for example to reduce user frictions via an understanding of typical journeys.

[0400] As will be described below, a user journey may be defined that includes one or more steps. Each step can correspond to one or more events from one or more data sources. Therefore, a user journey can indicate occurrences of events across one or more disparate data sources or data systems.

[0401] In some cases, the path of a particular user across one or more steps of a user journey, or the user journey of a particular user or entity can be referred to as a journey instance. In some embodiments, a journey instance can include a path through each of the steps of a user journey, and in certain embodiments, the journey instance includes a path through a subset of the steps of a user journey. Further, in certain cases, a user journey, such as a broadly defined grouping of touchpoints, steps, or events, a particular sequence of steps or touchpoints, or a grouping of multiple particular user's journeys may also be referred to as a journey model.

[0402] A system (e.g., the data intake and query system 108) can execute queries based on the steps, and provide results (e.g., in one or more user interfaces) to reviewing users. For example, the results can indicate occurrences of touchpoints that may occur along a user journey. To relate these results to individual entities (e.g., users), for example touchpoints of a specific entity, the system can stitch events together that are related to each entity. However, as different events may include machine data generated from disparate systems, these events may not be easily relatable. For example, an event describing a first touchpoint of a user may identify the user in a first way (e.g., a name of the user), while an event describing a second touchpoint of a user may identify the user in a second way (e.g., a phone number of the user).

[0403] As will be described below, with respect to FIG. 19, one or more stitching schemes can be utilized to relate events. As described above, each step may be associated with a particular data source. For steps associated with a same data source, the events which satisfy search queries corresponding to these steps may be rapidly relatable. For example, the events from this same data source that are related to a same entity may include a portion of same information. A particular field, for example a Session ID or User ID, may include a same value for events related to a same entity. Therefore, a stitching scheme for these events may specify that events including a same value for the particular field are related to a same entity.

[0404] However, for steps associated with different data sources, the events which satisfy search queries corresponding to these steps may not be immediately relatable. A stitching scheme for these events may therefore include utilization of a lookup table that correlates events associated with different data sources. For example, and with respect to the example described above, a lookup table can correlate names of users with their phone numbers. Another stitching scheme for these events may utilize 'gluing events', which can represent intermediate events that include information associated with a first a data source and information associated with a second data source. As an example, a first computing system may trigger a second computing system, and the triggering may specify a Session ID or User ID related to an entity. The second computing system may record this specified information in machine data, and further record its Session ID or User ID. The system can execute one or more search queries to identify these gluing events, and therefore relate events that are associated with the first computing system and the second computing system.

[0405] While reference is made herein to a search query, it should be understood that search query can encompass any search of information that causes the system to determine satisfaction of particular constraints, such as whether par-

ticular values, fields, and so on, are included in events. As an example, a search query may be specified according to the Splunk Processing Language (SPL) described above.

[0406] As an example of a user journey, a user journey can include steps related to processing of a user application (e.g., application for particular network credit application, job application, and so on). For example, a first step may be associated with receipt of an application. The first step may specify a query to identify occurrences of a particular value for a field included in events. The field may be related to actions performed by users, and the particular value may reflect the action of receiving an application submitted by a user. In the example first step, the data sources may include information received from, or generated by, computing systems at which applications are received. As described above, these data sources may be specified by a user creating the user journey, or optionally these data sources may be automatically selected by the system (e.g., based on analyzing the user journey). For the example user journey, additional steps may further specify queries associated with the application's processing and/or status. Each of these additional steps may cause application (e.g., execution) of search queries on differing data sources, such that a user's application may be monitored across the data sources.

[0407] As will be described below, for example with respect to FIGS. 19-27, a user can create a user journey through efficient user interfaces that succinctly mask the complexities associated with analyzing millions, billions, and so on, of events produced from machine data of disparate computing systems. With respect to the example of an application described above, a user can indicate data sources which include events describing status information of an application. The user can then indicate how events correlate across data sources (e.g., stitching schemes as described above). For example, as described above a lookup table can be utilized to correlate information included in events that are associated with different data sources. Steps can then be defined for the user journey, and, as will be described, the search queries specified by each step can be generated via minimal user interactions with a user interface. Optionally, the search queries can be generated by the user, for example, using a query language (e.g., SPL as described above).

[0408] As will be described, at least with respect to FIG. 21, to improve efficiency and ease of creating user journeys, common field identifiers can be created and utilized across data sources. For example, a user creating a user journey can indicate that a field name specific to a first data source corresponds with a particular common field identifier. Similarly, the user can indicate that a different field name specific to a second data source also corresponds to the particular common field identifier. In this way, the user can create a user journey via a set of common field identifiers such that steps can be rapidly defined. An example common field identifier may include 'UserID', and the user can indicate that a first field (e.g., a field specifying user name) in events associated with a first data source corresponds to 'User ID'. Similarly, the user can indicate that a second field (e.g., a field specifying phone number) in events associated with a second data source similarly corresponds to 'UserID'. Therefore, the user can create steps that can be used to generate queries to be applied to events associated with different data sources, with the queries specifying the common field identifier 'UserID'.

[0409] Upon creation of a user journey, the system can execute queries defined based on information provided by steps of the journey, and relate resulting events. As will be described, at least with reference to FIGS. 29 and 30, the system can analyze events being received in real-time, or the system can analyze events previously produced and stored in data stores, including field-searchable data stores. Additionally, as described below at least with reference to FIGS. 18 and 31-36, the system, or a presentation system in communication with the system, can generate user interfaces for presentation on user devices that describe the relating.

[0410] FIG. 18 illustrates an example user interface 1800 displaying a user journey 1802. The user interface 1800 can be an example of an interactive user interface generated, at least in part, by a system (e.g., a server system, the data intake and query system 108, and so on), and which is presented on (e.g., rendered by) a user device (e.g., a laptop, a computer, a tablet, a wearable device). For example, the user interface 1800 can be presented via a webpage being presented on the user device. As another example, the webpage may be associated with a web application (e.g., executing on the data intake and query system 108) that receives user input on the user device and updates in response. Optionally, the user interface 1800 can be generated via an application (e.g., an 'app' obtained from an electronic application store) executing on a user device, and the application can receive information for presentation in the user interface 1800 from an outside system (e.g., the data intake and query system 108).

[0411] User interface 1800 includes a graphical depiction of an example user journey 1802 that includes example steps 1806A-F. As described above, a user journey includes one or more steps, with each step corresponding to one or more queries to be applied to events associated with data sources. A particular entity, such as a user or object, can be monitored as it traverses a user journey. For example, an initial event identifying an example user that satisfies one or more queries corresponding to a first step may be correlated with (e.g., related to) a second event identifying the example user satisfying queries corresponding to a second step. In this way, the example user can be determined to have traversed from the first step to the second step. Similarly, events identifying multitudes of users can be similarly monitored, and related to determine which events are associated with a same user. User interface information describing results of the relating can be presented.

[0412] FIG. 18 illustrates summary information associated with example user journey 1802. As illustrated, steps 1806A-F are graphically connected via respective visual links 1803 between the steps. These links indicate transitions between steps, for example the visual link 1803 indicates users' transitioning from step 1806A to step 1806C. Based on monitoring events for occurrences of the steps 1806A-F, user interface 1800 presents indications of a total number of users 1810 who have initiated user journey 1802, indications of a quantity of users associated with each step (e.g., visual element 1808 may represent a quantity of users, with the element 1808 optionally sized according to a number of users associated with the visual element 1808 as compared to the total number of users 1810), and so on. Additional summary information includes average times associated with each step (e.g., transition between step 1806A and step 1806B is illustrated as taking 44 minutes). In this way, a reviewing user can utilize the user interface 1800 to view

information otherwise buried inside complex machine data and events, via an easy to digest user interface 1800.

[0413] Optionally, the visual element 1808 can represent a single user. As illustrated, visual element 1808 is illustrated as transitioning between step 1806D and step 1806A. The example user journey 1802 may illustrate particular steps (e.g., major steps, for example as specified by a user), but the user journey 1802 may include additional steps not illustrated. Thus, there may be steps between the illustrated steps 1806D and 1806A. To determine the single user's location along with a visual link between step 1806D and 1806A, the system can utilize a number of remaining (e.g., uncompleted) steps between the steps 1806D, 1806A. Optionally, even without these additional steps, the system can predict that the single user is transitioning (e.g., the single user is likely to be transitioning) between the steps 1806D, 1806A, based on a time since the single user completed step 1806D. That is, the system can determine an average time from completion of step 1806D to completion of step 1806A across all users, or users with that share features similar to the single user (e.g., location, demographics, historical information, and so on). In this way, the system can model the visual element's 1808 location along a visual link based on a time since the single user completed step 1806D. For example, the system can identify an event satisfying a query corresponding to step 1806D, and utilize timestamp information included in the event.

[0414] In the example of FIG. 18, user journey 1802 describes steps towards completion of creating a user account. Initial step 1806A indicates creation of a user account, for example an event can be identified that includes machine data associated with the initial creation of the user account. The final step 1806F indicates implementation of assigned network access rights associated with the created user account. As illustrated, different paths from the initial step 1806A to the final step 1806F are included. For example, a first path can traverse steps 1806A, 1806C, 1806E, and 1806F. A second path can traverse steps 1806A, 1806B, 1806C, 1806E, and 1806F. This second path differs from the first path in that, for at least one user, user information was obtained (e.g., step 1806B). For example, one or more events specifying the example user may have indicated that user information was obtained (e.g., an event can indicate that a network call to a storage system was performed, or an event can indicate that a request for user information, such as an email, was provided, and so on). As described above, each step can correspond to, or be used to generate, one or more queries to be executed, and the executed queries for step 1806B may have identified events specific to the example user. In contrast, a different example user who traversed the first path may have had his/her user information entered at a time of user account creation in step 1806A.

[0415] As will be described in more detail below, with respect to FIG. 28, an ordering of the steps 1806 A-F, and thus a determination of the links 1803 between steps 1806A-F, can be determined by the data intake and query system 108 based on monitoring and/or relating events. For example, the data intake and query system 108 can identify occurrences of each step for a particular user, and identify a path traversing the steps based on timestamp information. Similarly, the data intake and query system 108 can determine alternate paths based on monitoring multitudes of users. In this way, the data intake and query system 108 can

operate with limited assumptions, such that all paths between steps that users take can be empirically determined. As will be described below, with respect to FIG. 22, the data intake and query system 108 can determine most-used paths, and further cluster entities (e.g., users) according to paths they traverse.

[0416] The user interface 1800 further illustrates representations of users who are transitioning between steps. For example, visual element 1808 (e.g., the visual element can be a circle, square, an arbitrary shape or polygon, and so on) can represent a particular number of users who have completed a step and are traversing to a subsequent step. Optionally, the user interface 1800 can illustrate movement of the visual elements between steps. For example, an animation of the visual elements transitioning between steps 1806A-F can be presented. Optionally, a speed associated with the movement can be based on a measure of central tendency of an amount of time a transition takes. As will be described below, the data intake and query system 108 can monitor occurrences of steps, and determine statistical information associated with the monitoring. In this way, the system 108 can determine that, for example, transitioning from step 1806A to step 1806C takes 44 minutes (e.g., a measure of central tendency of transitions can be determined to take 44 minutes).

[0417] Additionally, the user interface 1800 includes textual information 1804 associated with the user journey (e.g., "User Account Creation"). This textual information 1804 can be specified by a user creating the user journey 1802. Optionally, the textual information 1804 may be automatically generated by the data intake and query system 108 based on an analysis of included steps 1806A-F. As an example, utilizing machine learning techniques the data intake and query system 108 can analyze queries specified in the steps 1806A-F, and determine corresponding textual information that reflects the queries. For example, the system 102 can compare the queries with queries utilized in other user journeys, to determine similar user journeys. The textual information 1804 associated with these similar user journeys may be analyzed and updated via the machine learning techniques based on the specific queries of user journey 1802.

[0418] FIG. 19 illustrates an example process 1900 for creating a user journey. For convenience, the process 1900 will be described as being performed by a system of one or more computers (e.g., the data intake and query system 108).

[0419] At block 1902, the system receives information specifying data sources associated with a user journey. As described above, a user journey can utilize events associated with particular data sources. For example, a user creating the user journey may be interested in particular touchpoints (e.g., user interactions) with disparate computing systems. The user can therefore indicate data sources related to these touchpoints. For example, if a touchpoint is associated with an entity placing a call to a call center, the user creating a user journey can specify a data source that records information associated with such calls.

[0420] Optionally, as the system receives information specifying data sources, the system can utilize machine learning techniques to recommend additional data sources that may be of interest to the user. For example, if the user specifies a data source associated with a call center, the system can recommend a data source storing touchpoints (e.g., user interactions) with a front-end system. The system

may assume that the user will want to understand why a call center was called, and therefore can recommend a data source indicating specific user interactions that led to a call being placed. That is, the front-end system may record machine data describing user interactions on a web page, with the web page specifying a call number. Therefore, if a call to the call number was placed, the user creating the user journey may be interested in the user interactions with the web page which led to the call. The system can analyze prior created user journeys, and determine clusters of data sources which are generally utilized together. In this way, the system can recommend data sources to the user to increase a speed at which the user journey is created.

[0421] At block 1904, the system maps fields included in events associated with the specified data sources to common field identifiers. Each data source may include events with differing field identifiers. For example, values of identifying information included in events associated with a first data source may correspond to a different field identifier than values of identifying information included in events associated with a second data source. The system can map these different field identifiers to a same common field identifier.

[0422] As an example, and as will be described in more detail with respect to FIG. 20, a common field identifier may relate to a step. For example, a step may optionally be defined as corresponding to values of a particular field included in events. For example, field values for a field named 'action' of events associated with a particular data source may indicate user interactions. Therefore, the system can receive a mapping of the 'actions' field to a common field identifier (e.g., "Steps" as illustrated in FIG. 20).

[0423] As another example, and as will be described in more detail below with respect to FIG. 21, a common field identifier may relate to a session identifier (e.g., 'Session ID' as illustrated in FIG. 21). A session identifier can indicate a particular session of an entity, and can be utilized by a computing system to reflect interactions of the entity. For example, the computing system may generate machine data that tracks interactions of an entity using the same session identifier. To stitch events together that relate to a particular entity, the system can therefore identify all events that include a same session identifier.

[0424] At block 1906, the system obtains information indicating correlations between data sources. As described above, and as illustrated in FIGS. 24-27, stitching schemes can be utilized to relate events from same data sources, and also relate events across data sources. That is, to determine whether an entity has completed a user journey, the system may have to relate events together to identify that the entity has completed the user journey.

[0425] A user of the system can specify these stitching schemes. For example, the user can indicate that for events associated with a same data source, a particular field is to be utilized to identify related events. As described above, with respect to block 1904, a particular field may be a session identifier, and the user can specify that the session identifier field be utilized to identify related events. As another example, the user can indicate that a user identifier be utilized to relate events from a particular data source. For example, events from the particular data source may include a user name associated with an interaction. The user can therefore specify that user name be utilized to identify related events from the particular data source.

[0426] Additionally, to relate events associated with different data sources, the user can indicate stitching schemes for these different sources. As an example, and as illustrated in FIG. 24, a user interface can be presented to the user identifying the data sources selected in block 1902. The user can then specify a stitching scheme between each of the identified data sources. For example, the user can indicate that a lookup table is to be utilized between a first data source and a second data source. In this example, the user can specify a field in events associated with the first data source that are correlated with events associated with the data source via a lookup table. As another example of a stitching scheme, the user can indicate that a gluing event is to be utilized to relate events from a first data source and a second data source. In this example, the system can execute a query to identify events (e.g., gluing events) from, for example, the second data source that include a field associated with the first data source and a field associated with the second data source. Based on these identified events, identifiers associated with the first data source and second data source can be related. Further description of a gluing event is included below, with respect to FIG. 28.

[0427] The system may optionally utilize machine learning techniques to determine a stitching scheme. For example, the system can analyze field identifiers included in events associated with the selected data sources. Utilizing similarity rules (e.g., a Levenshtein distance), the system can determine that identifying information may be similarly labeled (e.g., a field identifier labeled 'processID' in a first data source may correspond with a field identifier labeled 'process_ID' or 'process identifier' in a second data source). Optionally the system can automatically select stitching schemes utilized in prior created user journeys. For example, the system can store information indicating correlations between the data sources, and can automatically utilize stitching schemes created for prior user journeys.

[0428] At block 1908, the system obtains selections of steps to be included in the user journey. As will be described below, with respect to FIG. 23, the system can present steps that are able to be selected for inclusion in the user journey. For example, the steps may have been previously created. Additionally, each step may optionally be specific to a particular data source. Therefore, the steps can correspond to values of a particular field identifier included in events associated with a particular data source. For example, and as described above, a field identifier can be associated with user interactions or touchpoints (e.g., a field identifier 'action'). The system can present common values of this field identifier as determined from the events associated with the particular data source, and the user can select one or more of these values to correspond to steps of the user journey. Subsequently, the user can select a different data source, and select values of a field identifier as corresponding to steps for this different data source.

[0429] In some cases, the system can recommend additional steps to the user based on current selections of steps. That is, the system can analyze prior created user journeys and determine clusterings of steps (e.g., steps that are commonly included in a same user journey). The system can therefore cause presentation of recommend steps, which the user can select or discard.

[0430] At block 1910, the system causes application of the created user journey. Upon selection of the steps, a user can indicate that the user journey is to be applied to events. For

example, the user journey can be applied as will be described below with respect to FIG. 29. It will be understood that fewer, more, or different steps can be included in routine 1900. For example, the system can generate the queries for each step based on the information received from the user via one or more user interfaces.

[0431] FIGS. 20-27 illustrate user interfaces associated with creation of a user journey, for example as described in FIG. 19. For example, FIG. 20 illustrates a user interface for specifying a field included in events of a particular data source (e.g., "Self-Service Portal") that is to correspond with a common field identifier associated with available steps. FIG. 21 illustrates a user interface for specifying a field included in events that is to be utilized to relate events associated with a same data source (e.g., "Self-Service Portal"). FIG. 22 illustrates a user interface for specifying information included in events that is to be stored when events satisfying a step's queries are located. For example, if a step is related to a user adding an item to a cart, FIG. 22 can be utilized to specify that for events satisfying this step, the system is to store an identification of the specific items being added. FIG. 23 illustrates a user interface for selecting steps to be included in a user journey. FIGS. 24-27 illustrate user interfaces for relating events between different data sources, for example user interfaces to specify stitching schemes.

[0432] FIG. 20 illustrates an example user interface 2000 for identifying a field identifier whose field values are to indicate potential steps of a journey in a particular data source. As described above, steps of a user journey can be created, with each step being associated with a touchpoint or user interaction. In the example illustrated in FIG. 20, a common field identifier 'Steps' 2002 can represent generic steps for a journey, and the user interface 2000 can be utilized to identify a particular field identifier from the data source fields 2004 that is mapped to the generic step of the journey. That is, field values of field identifier selected from the data source fields 2004 can be utilized to identify occurrences of steps in a journey.

[0433] In the illustrated embodiment, the user interface 2000 includes a list of data source fields 2004 of events associated with the particular data source (e.g., data source "Self-Service Portal"). A user of the user interface 2000 can indicate which field identifier from the data source fields 2004 is to be used to identify steps in a journey, e.g., the data source field 2004 whose field values correspond to steps of the user journey. In the illustrated embodiment, the user of user interface 2000 has selected field identifier 'action'. Upon selection, user interface 2000 has updated to list one or more field values 2006 associated with the selected field identifier. That is, the data intake and query system 108 identifies events associated with the particular data source, and identifies field values included in events for the field 'action'. In the illustrated embodiment, the field values for the field 'action,' include at least: Login, Logout, Addtocart, RemoveFromCart, Checkout, viewProduct, compareProduct, Download, and ReadReview. In some cases, the field values 2006 can correspond to the most common field values for the field 'action'. However, it will be understood the system can determine and display the field values 2006 using a variety of techniques.

[0434] As described in greater detail herein with reference to FIG. 23, a user can select one or more of the field values 2006 as being a step in a user journey. Further, the data

intake and query system **108** can generate, for each step, a query that identifies the field identifier ‘action’ and a respective selected value of the field identifier. In this way, if the user later selects value ‘Login’ **2008** as a step, the data intake and query system **108** can execute a query on events associated with the particular data source that causes identification of events that include the value ‘Login’ **2008** for the field ‘action’.

[**0435**] FIG. **21** illustrates another example user interface **2100** for mapping a field identifier in a particular data source (e.g., “Self-Service Portal”) to a common field identifier **2102**. User interface **2100** enables a user to map a specific field identifier **2104** of events associated with the particular data source to a common field identifier **2102**. In the example, the user is mapping the specific field identifier **2104** ‘jsessionID’ to the common field identifier **2102** ‘Session ID’. As described above, the common field identifier **2102** ‘SessionID’ can be utilized to stitch events together into a particular user’s journey. For example, the common field identifier **2102** ‘SessionID’ can be utilized to relate events associated with the particular data source. As another example, the user can map field identifiers included in other data sources selected for use with a user journey to the same common field identifier **2102**. Since field values for the common field identifier **2102** ‘SessionID’ in the various events or machine data can be unique, the data intake and query system **108** can utilize the field values for the common field identifier **2102** ‘SessionID’ of each data source to stitch events together as part of a particular user’s journey. For example, all events in a data source that have the value “WC-SH-G68” for the field “jsessionID” can be mapped together as part of a particular user’s journey.

[**0436**] In some embodiments, the common field identifier ‘User ID’ can be utilized to stitch events together. In some cases, the system can automatically map a specific field identifier **2104** from the particular data source to a common field identifier **2102**. For example, the system can automatically map the specific field identifier **2104** “_time” for the events associated with the particular data source with the common field identifier **2102** ‘Time Stamp’, and so forth.

[**0437**] FIG. **22** illustrates an example user interface **2200** for specifying information that is to be recorded for a particular step. As described above, the system can execute queries generated based on steps and obtain events satisfying the queries. In the example of FIG. **22**, a particular step **2202** is associated with a user interaction of adding a product to a cart. A user of the data intake and query system **108** may wish to record, for this particular step **2202**, information associated with the user interaction. That is, upon identifying an event satisfying a query associated with adding a product to a cart, the system **108** can record (e.g., store) relevant information included in the event (e.g., the information can be utilized to provide context).

[**0438**] Accordingly, the user interface **2200** presents field identifiers **2204** included in a data source that are associated with the particular step **2202** “Addtocart.” A user of the user interface **2200** can select one or more of the field identifiers **2204**, indicating that values of these field identifiers will be recorded. In the example of FIG. **22**, the user has selected fields ‘productID’ and ‘ProductName’. In this way, upon a determined occurrence of the particular step, the data intake and query system **108** can obtain a ‘productID’ and ‘ProductName’ associated with the occurrence. Therefore, the system **108** can identify events associated with the ‘Addto-

cart’ **2202** step, and obtain contextual information from the identified events (e.g., product id and product name).

[**0439**] In some cases, the system can automatically record other information related to the events identified in the queries, such as the field values that correspond to the common field identifiers. For example, the system can automatically record the time stamp of the events, the field value that corresponds to the field identifier of the data source that was related to the common field identifier Session ID, and so on.

[**0440**] FIG. **23** illustrates a user interface **2300** for selecting steps to be included in a user journey. As described above, with respect to FIG. **19**, multiple data sources may be selected for a user journey being created. For each of these data sources, one or more steps of the user journey may be selected. That is, each step may be associated with a user interaction or touchpoint that is specific to a respective data source.

[**0441**] User interface **2300** includes indications of five data sources **2302** selected for a user journey (Call Center IVR, Point of Sale, Mobile App, CRM, NPS Survey). A user of the user interface **2300** has selected the data source ‘Call Center IVR’ **2304**, and the system displays the steps **2306** that are available to be selected from the data source ‘Call Center IVR’ **2304** for inclusion in the user journey. In some cases, the available steps **2306** can correspond to field values of a data source field **2004**, where the field values are included in events associated with the data source ‘Call Center IVR’ **2304**. For example, with reference to FIGS. **20** and **23**, the available steps **2306** (e.g., Explore Product, Compare Product, Add Product to . . . , Remove Product, Checkout, Change profile, Add credit card) can correspond to field values of an ‘action’ field in the data source ‘Call Center IVR’ **2304**. For example, once a user selects the ‘action’ field in user interface **2000**, the available steps **2304** are obtained as field values for the selected field ‘action’. In the illustrated embodiment, a user of user interface **2300** has selected six steps **2308** for the user journey.

[**0442**] For the selected steps **2308** that are associated with the same data source **2304**, the system can relate the steps as described above with respect to FIG. **21**. That is, events satisfying these steps can include the same field value for one or more fields (e.g., the same field value for the field ‘jsessionID’), as they are all associated with the same data source **2304**. Therefore, the events can be related based on, for example, Session ID or User ID as described above. For selected events **2308** that are associated with different data sources, the system can relate the steps using a variety of technique, examples of which are described below with reference to FIGS. **24-27**.

[**0443**] FIG. **24** illustrates an example user interface **2400** for specifying correlations between data sources **2402** selected for a user journey. As described above, with respect to FIG. **19**, events associated with different data sources **2402** may include different information associated with an entity, such that determining that a first event and a second event from different data sources are associated with a same entity (e.g., user) can be difficult.

[**0444**] User interface **2400** presents a matrix **2404** specifying various combinations of the selected data sources **2402**. A user of user interface **2400** can indicate for any combination, how events associated with the combination correlate. For example, a user has specified that events associated with data source ‘Self-Service Portal’ and events

associated with data source 'CC IVR' can be correlated using a lookup table 2406. That is, to stitch events together from these data sources, the system can use a lookup table to translate between the identifying information of one to the identifying information of the other. As an example, events associated with 'Self-Service Portal' may specify a name of an entity, and events associated with 'CC IVR' may specify an address of the entity. A lookup table may therefore be utilized to translate between name and address.

[0445] FIG. 25 is a user interface 2500 illustrating a first example stitching scheme 2502. To correlate between a first data source 2504 and a second data source 2506, a user of user interface 2500 has selected the stitching scheme, 'Direct Match'. A direct match can indicate that events associated with the data sources 2504, 2506, include same identifying information, which may be found in fields having the same or a different field identifier. For example, one data source may use the field identifier 'username' for a user's full name, whereas another data source may use the field identifier 'userID' for the user's full name. Although the field identifiers are different, the field values for events in the two systems that are related can be the same.

[0446] In the illustrated embodiment, events associated with data source 2504 and events associated with data source 2506 may both include a field 'Session ID' 2508, and the field values for the events in the different data source can match. Accordingly, the user can specify the field identifiers 'Session ID' 2508 for each data source for association. Upon selection, the user interface 2500 can update with example matching values 2510 associated with each field identifier 2508, to ensure that a correct field identifier 2508 was selected. In some embodiments, when relating events based on a 'Direct Match', the system can use a variety of techniques to identify the related events. In some cases, the system can determine whether the field values based on identical matches or similar matches using fuzzy logic. For example, the system can determine that a field value in an event in one system of 'David G Smith' can be related to an event from a different data source having 'Dave Smith', 'David Smith', or David Smth', etc.

[0447] In some embodiments, the user interface 2500 can be used to identify a field identifier in different data sources that are to correspond to the common field identifier 2102. For example, a user can enter a field identifier for a field in the Self-Service Portal data source and a corresponding field identifier for a field in the Call Center IVR data source that are to be used as the common field identifiers 2102 'Session ID' for the respective data sources. The entered field identifiers can be used to correlate events from different data sources as part of the same journey.

[0448] FIG. 26 is a user interface 2600 illustrating a second example stitching scheme 2602. To correlate between a first data source 2604 and a second data source 2606, a user of user interface 2600 has selected the stitching scheme, 'Lookup Table'. As described above, a lookup table can indicate that events associated with the data sources 2604, 2606, include different field identifiers for the same or similar information. The user can specify field identifiers 2608, 2610, associated with each data source 2604, 2606, that include values specifying identifying information. That is, to relate events from these data sources 2404, 2406, a lookup table translating between values of field identifier 2608 and values of field identifier 2610 is to be utilized. The user can specify a lookup table (e.g., a network address of

a lookup table, a file address, and so on) that includes information correlating between the identifying information. The user interface 2600 can then update to specify values 2612 determined to correspond to a same entity based on the specified lookup table. In this way, a user of user interface 2600 can ensure the proper field identifiers 2608, 2610, were selected.

[0449] FIG. 27 is a user interface 2700 illustrating a third example stitching scheme 2702. To correlate between a first data source 2704 and a second data source 2706, a user of user interface 2700 has selected the stitching scheme, 'Gluing event' 2702. As described above, a gluing event can indicate that an event specifies identifying information from both the first data source 2704 and the second data source 2706. For example, a first computing system may trigger a second computing system, and the second computing system may generate machine data that includes identifying information received from the first computing system along with identifying information utilized by the second computing system. In some cases, the data intake and query system 108 can execute a query from events associated with the second data source 2706, and therefore obtain occurrences of the handoff between the first computing system and second computing system. In this way, events associated with data sources 2704, 2706, can be related to a same entity. In the illustrated embodiment, a user has identified that field values of the 'UserID' field of the 'Self-Service Portal' data source 2704 correspond to field values of the 'PreviousID' field of the 'Procurement System' data source 2706. As such, the system can identify a gluing event from the 'Self-Service Portal' data source 2704 or the 'Procurement System' data source 2706 that maps a 'UserID' from the Self-Service Portal' data source 2704 to the 'PreviousID' of the 'Procurement System' data source 2706. The field values for the UserID and PreviousID can then be used to identify steps of a journey that span the two data sources 2704, 2706.

[0450] Utilizing example FIGS. 20-27, a user can create a user journey and specify how events are to be related (e.g., events associated with a same entity). Upon creation, the data intake and query system can execute queries based on the steps of the user journey, and relate events satisfying the queries. In this way, a user's progress through the user journey can be monitored, and user interfaces describing results of the user journey can be presented to a user (e.g., as will be described below, with respect to FIGS. 31-36).

[0451] FIG. 28 illustrates a representation of steps 2802-2810 included in a user journey. As described above, steps can be included in a user journey being created. For example, a step can be selected from a pre-existing list of steps, a user can specify unique queries corresponding to a step, a step can be automatically included based on the data intake and query system's 108 analysis of steps already selected for inclusion (e.g., the system 108 can utilize machine learning techniques to recommend additional steps), and so on. These steps can be specific to particular data sources, for example search queries corresponding to the steps can be applied to events from the particular data sources.

[0452] Panel 2800 illustrates example steps 2802-2810 that have been included in an example journey. As described above with respect to FIG. 18, the steps may have no order associated with them. That is, each step may be defined, such that events satisfying associated search queries, and thus

occurrences of each step, can be located—however, an order may not be specified for the steps.

[0453] As the data intake and query system **108** relates events (e.g., executes search queries corresponding to the steps **2802-2810**, and relate the returned events), the system **108** can identify occurrences of the steps **2802-2810** that are associated with a same entity (e.g., user). For example, the system **108** can identify events that satisfy the queries associated with the steps **2802-2810**. As described above with respect to at least FIG. **5**, each event can include a timestamp. The data intake and query system **108** can therefore determine an order associated with each step, based on a respective timestamp of an event satisfying queries corresponding to the step.

[0454] Optionally, a user may specify a particular order of one or more steps, such as an initial step and a final step. For example, particular entities may traverse through a portion of the user journey, or initiate at a different step than expected. Based on information indicating an initial step and a final step, the data intake and query system **108** can therefore identify that these particular entities have not completed the user journey, or have avoided one or more initial steps.

[0455] Panel **2820** illustrates the steps **2802-2810** presented with links specifying paths traversed by users. For example, as the data intake and query system **108** relates events returned as a result of application of queries corresponding to the steps, the system **108** can determine connections between the steps **2802-2810**. These connections can therefore indicate a determined order associated with the steps **2802-2810**. For example, FIG. **28** illustrates each step along with a directed link connecting to another step. In this way, the user journey can represent a directed graph, such that differing paths can be traversed from the initial step **2802** to the final step **2810**. To determine the order associated with each path, the data intake and query system **108** can stitch together events associated with respective users that satisfy search queries corresponding to the steps **2802-2810**. Based on analyzing timestamps associated with each user's stitched together events, the data intake and query system **108** can determine an order of the steps **2802-2810** for the user.

[0456] As an example of stitching together events, the data intake and query system **108** can identify a first event satisfying search queries corresponding to step **B 2804**. Based on analysis of the first event, the data intake and query system **108** can identify an entity (e.g., user) specified in the first event (e.g., a value of a field associated with user identification can be obtained). Similarly, the data intake and query system **108** can identify additional events that satisfy search queries corresponding to step **C 2806**. The data intake and query system **108** can then stitch the first event together with one of the additional events that specifies the same entity, for example based on a stitching scheme.

[0457] In this example, the first event and the additional event may include a field that indicates the same value associated with user identification (e.g., a user name) or session identification (e.g., a process ID). While these fields may optionally have different identifiers (e.g., field names), as described above with respect to FIG. **25**, the data intake and query system **108** can store information indicating field identifiers that are to be used to stitch the events.

[0458] As another example, the first event and the additional event may include respective fields that indicate

values associated with user identification, but with values that may be different. For example, and as described above with respect to FIG. **26**, the data intake and query system **108** can utilize information (e.g., a lookup table) to correlate between values of the respective fields. As an example, a user's name or other identifier may be included in the first event, while a user's phone number may be included in the additional event. The data intake and query system **108** can determine that the first event and additional event are associated with a same user based on the utilized information.

[0459] As an additional example, the first event and the additional event may be stitched together via information included in an intermediate event (e.g., a 'gluing event', as illustrated in FIG. **27**). For example, the first event may include information specifying a user's name. The additional event may include a different identifier, and no information correlating the two may be obtained a priori (e.g., the system **108** may not have access to a lookup table as described above). However, an intermediate event may include the user's name along with the different identifier. The data intake and query system **108** can therefore determine that the first event and the additional event can be stitched together, based on the intermediate event.

[0460] As a more detailed example of a gluing event, a first event may be identified as satisfying search queries corresponding to step **A 2802**. This first event may be associated with a first data source, and the first data source may include machine data generated by a first computing system. This first computing system can generate machine data that references user names. Therefore, events produced by the data intake and query system **108** from this machine data can include user names referenced by a field. Similarly, a second event may be identified as satisfying search queries corresponding to step **B 2804**. This second event may be associated with a second, different, data source, and the second data source may include machine data generated by a second computing system. This second computing system may record interactions (e.g., touchpoints as described above) differently than the first computing system. For example, the second computing system may utilize different information to identify a user.

[0461] The first computing system may provide information to the second computing system, for example the first computing system may trigger a particular action or interaction on the second computing system. In response to the trigger, the second computing system may generate machine data specifying an identifier provided with, or determined based on, the trigger (e.g., an identifier of a user utilized by the first computing system). The generated machine data may further specify an identifier utilized by the second computing system. Therefore, this handoff between the first computing system and the second computing system may specify identifiers of a same entity (e.g., user) as used by the respective computing systems. The data intake and query system **108** can produce an event that includes this generated machine data, with a first field specifying the identifier utilized by the first computing system and a second field specifying the identifier utilized by the second computing system. Similarly, instead of user identifiers, a gluing event may utilize session or process identifiers. That is, the first computing system may include session identifiers in

machine data, and the second computing system may record these session identifiers along with its own session identifiers.

[0462] To stitch the first event and the second event together, the data intake and query system 108 can access information specifying respective field identifiers of the first field and the second field. The data intake and query system 108 can then analyze intermediate events (e.g., the system 108 can execute a query to identify ‘gluing events’ as illustrated in FIG. 27) that include both the first field and the second field. For example, the data intake and query system 108 can analyze events produced from machine data generated by the second computing system for occurrences of the intermediate events. Upon identification of an intermediate event, the data intake and query system 108 can obtain respective values of the first field and second field. Since these values correspond to a same user, or same session, the data intake and query system 108 can utilize the obtained values to stitch together the first event and second event. In this way, the data intake and query system 108 can determine that a same user completed step A 2802 and step B 2804.

[0463] Each of the stitching schemes described above, may be utilized when correlating entities across data sources. For example, a first data source may be correlated with a second data source according to the direct matching scheme. Similarly, the first data source may be correlated with a third data source according to the lookup table, or intermediate event (e.g., ‘gluing event’) schemes. For ease and efficiency of use, and as described above, a user creating a user journey can utilize a user interface to rapidly indicate the appropriate stitching scheme. For example, FIG. 24 illustrates a user interface 2400 that enables the rapid indication of stitching schemes across data sources.

[0464] Thus, since the data intake and query system 108 can monitor each entities’ (e.g., users) traversal through the user journey, the system 108 can determine one or more path’s orderings of the steps 2802-2810 as illustrated in panel 2820.

[0465] FIG. 29 is a flowchart of an example process 2900 for presenting results associated with a user journey. For convenience, the process 2900 will be described as being performed by a system of one or more computers (e.g., the data intake and query system 108).

[0466] At block 2902, the system obtains information associated with a user journey. The obtained information can relate to steps of the user journey, one or more queries performed as part of a step, field values to be extracted from events identified by the queries, etc. For example, events can be events as described above with respect to FIG. 5.

[0467] As described above, a user journey can include steps that identify relevant data from one or more data sources. In some embodiments, the system can use the information to define or generate one or more search queries to be applied to events. In certain embodiments, the system can use the information to generate one or more search queries for each step of the user journey. Accordingly, the obtained information can include a definition of the steps of the journey, such as steps A-N 2901 as illustrated in FIG. 29.

[0468] As described above, a user journey can be utilized to provide a representation of specific interactions (e.g., touchpoints) associated with entities (e.g., users). Each step may therefore correspond to search queries that cause identification of events recording these specific interactions. For

example, using the information from a step, the system may define a query that causes identification of events recording users adding an item to a cart, or removing an item from a cart. This defined query can therefore specify a particular field identifier associated with user actions, along with a specific value indicating addition, or removal, of an item from a cart. In addition, the example step may further specify one or more data sources associated with the events that satisfy the query. As an example, a particular data source may produce events recording user interactions on a front-end web page presented on user devices. For example, the events may be produced from machine data generated by a server system (e.g., a web application on the server system, a front-end module recording user interaction logs, and so on). The example step may specify that only events associated with this particular data source are to be analyzed.

[0469] Additionally, and as described above, the accessed information can indicate stitching schemes to enable correlation across data sources. For example, the user journey may optionally include steps that specify multiple data sources. To ensure that a same entity (e.g., user) is able to be monitored in each step, the accessed information can indicate particular stitching schemes between the data sources. For example, the accessed information can indicate that events associated with a first data source include a field identifier with same values as values of a different field identifier included in events associated with a second data source. In this way, the system does not require guarantees that field identifiers are utilized consistently across data sources. Similarly, utilizing a lookup table and gluing events (e.g., as described above), the system can stitch events together that include both differing field identifiers and differing values.

[0470] Optionally, in addition to one or more search queries corresponding to a step, the step can further define information included in events satisfying the search queries that is to be stored. For example, an example step may be used to generate a query that causes identification of events recording users’ adding items to their carts. As described above, this example step may correspond to a query that specifies a particular field identifier along with a value of the field identifier (e.g., a value indicating an action to add an item to a cart). The system can identify events that satisfy this query, and as will be described below with respect to block 2904, generate information indicating, at least, that a user associated with each event completed the example step. In this way, each users’ traversal through the user journey can be monitored. In addition to this generated information, the example step can specify that values of one or more additional fields are to be stored. For example, the example step can specify that values of a field associated with a product being added to a cart are to be stored. (e.g., the field can indicate values specifying a product name, a product identifier, a product SKU, and so on).

[0471] At block 2904, the system relates events returned as result of queries. As described above, the system executes the search queries based on the steps to obtain events satisfying the search queries. For example, and as illustrated in FIG. 29, the system can execute the search queries on events stored in the data stores 2905. Optionally, these data stores 2905 may be field-searchable data stores, and the system can apply a late binding schema to execute a query on the data stores 2905. In some cases, the data stores 2905 can correspond to Oracle databases, MySQL databases, and

so on. The system can then relate events returned as a result of these queries, for example to stitch the events as being associated with respective entities.

[0472] To increase efficiency and speed at which events can be returned, the system can optionally execute each step's search queries in parallel. For example, if the events are stored in data stores **2905**, the system can rapidly analyze the events according to the accessed information describing the user journey. Since each step's search queries may not be dependent on each other, that is there may be no data dependency across steps, the system can rapidly execute the search queries in parallel. For any returned event, the system can generate information specifying the satisfied step along with an identifier of an entity associated with the returned event (e.g., a user). In this way, the user's traversal through the steps can be monitored. For example, the system can return events indicating that a particular user completed the user journey. As another example, the system can return events indicating that a different user completed a portion of the steps. The system can update this generated information as new events are produced from newly received machine data. Optionally, the generated information can be an inverted index, with the inverted index referencing, for each entity, the returned events.

[0473] In certain cases, some returned events may include differing identifying information. That is, a first event returned as a result of execution of a first step's queries may include a name associated with an entity. The system can therefore generate information specifying that the entity completed the first step. Similarly, a second event returned as a result of execution of a second step's queries may include an address associated with an entity instead of the name. The system may therefore generate information specifying that an entity associated with the address completed the second step. Since the respective queries of the first step and the second step may optionally be executed in parallel, a system may be unable to stitch these two events together. However, the system can utilize a stitching scheme, for example as described in FIG. 19, to determine that the name of the entity, as included in the first event, corresponds with the address of the entity as included in the second event. For example, a lookup table may be stored in memory, such that the system can rapidly determine the correspondence. In this way, the system can stitch the first event and second event together, such that the system generates information specifying that the entity completed both the first step and the second step.

[0474] Optionally, the system may execute each step's search queries on events being received in substantially real-time. For example, disparate computing systems may generate substantially real-time machine data recording, as an example, interactions with the computing systems. The system can receive this machine data, and as described above, produce events that incorporate the machine data. As these events are produced, the system can optionally execute each step's search queries to determine whether the events satisfy any of the steps.

[0475] Optionally, as an event being received in substantially real-time is determined to satisfy a step's search queries, the event may be modified to reflect that satisfaction. For example, metadata describing completion of the step may be generated and included in the event. As an example with respect to a step of adding an item to a cart, the metadata can indicate that the step associated with an

adding an item to a cart was completed. For ease of reference, an inverted index associated with a user identified in the event can be updated to reference the event. In this way, the system can monitor and update the inverted index to determine the user's status with respect to completion of the user journey. That is, the events referenced in the inverted index can be modified to reflect respective steps that were completed. In this way, the system can access the inverted index for a particular user, and based on the references to events, rapidly identify the steps completed by the particular user.

[0476] Furthermore, an inverted index can be utilized to reference all events that indicate some, or all, user interactions (e.g., touchpoints) of each user, thereby creating a timeline of touchpoints. For example, the user interactions may be associated with steps of one or more user journeys. A user of the system may request, for example via a user interface as illustrated in FIG. 36 presented on his/her user device, that all touchpoints of a specified user be presented in the user interface. The system can therefore access the inverted index associated with the specified user and present information obtained from the referenced events. For example, the system can present times at which the touchpoints occurred (e.g., based on respective timestamps included in the events), along with information identifying the touchpoints. Similarly, and as illustrated in FIG. 27, a user of the system may request that specified touchpoints of a specified user be presented.

[0477] While relating the returned events, as described above, the system can determine statistical information associated with the steps. For example, based on timestamps included in the events, the system can determine an average (e.g., measure of central tendency) time that it takes to transition between the steps. As an example, the system can determine an average time for a user to add a product to a cart and then checkout. Alternatively, if the user removed the item from his/her cart, the system can determine an average time that the user has the product in his/her cart prior to removal. Similarly, the system can determine an average time that it takes users to complete all steps included in the user journey.

[0478] Optionally, the user journey may include differing versions, and each version may be monitored. For example, a designer may modify a web page that is presented to a first set of users, while retaining an original design of a web page that is presented to a second set of users. The designer may desire to understand whether the modified web page results in a faster average time for users to transition from adding a product to a cart, to checking out. To discriminate between the modified web page and the original web page, each event associated with the web page may be tagged as either the modified web page or the original web page. As an example, a computing system may provide machine data (e.g., log data specifying whether a user received the modified or original web page) to the system. The system can produce events from the received machine data, as described above with respect to FIG. 5, and can include a field indicating whether a user received the original or modified web page. The system can then determine statistical information associated with each version of the user journey. In this way, the designer can obtain empirical information related to his/her design choice.

[0479] At block **2906**, the system causes display of at least a portion of the results. Example user interfaces describing

results of the relating are described below, and illustrated in FIGS. 31-36. As described above, with respect to FIG. 18, these user interfaces can be presented on user devices of users. For example, the system can respond to requests from users of the system, and cause display of easy to understand information based on the requests.

[0480] FIG. 30 is a flowchart of another example process 3000 for presenting results associated with a user journey. For convenience, the process 3000 will be described as being performed by a system of one or more computers (e.g., the data intake and query system 108, a server system in communication with disparate computing systems that generate machine data).

[0481] At block 3002, the system accesses information associated with a user journey. As illustrated in FIG. 30, information describing a user journey 3001 can be accessed. Similar to the description of FIG. 29, the example user journey 3001 may include multiple steps each corresponding to one or more search queries. As will be described below, these search queries may be applied (e.g., executed) to identify events that satisfy the search queries.

[0482] The example user journey 3001 further indicates that a particular step includes one or more sub-steps. That is, the particular step is a nested user journey that defines sub-steps that are completed as part of the particular step. As illustrated, 'Step N' includes Sub-steps A-N, with each sub-step corresponding to respective search queries. Similar to a user journey, the sub-steps of a nested user journey can specify multiple data sources. That is, sub-step A may be defined as searching for machine data stored in a first data source, while sub-step N may be defined as searching for machine data stored in a second data source. In this way, a user creating a user journey can build off of prior created user journeys by incorporating them into the user journey as nested user journeys represented as single steps including sub-steps. A graphical representation of a user journey that includes a nested user journey is described below, and illustrated in FIG. 34. While a nested user journey is described with respect machine data in FIG. 30, a nested user journey may similarly be utilized with events (e.g., events as described above with respect to FIG. 29).

[0483] At block 3004, the system relates machine data returned as results of the queries generated based on the user journey. As similarly described above, with respect to FIG. 29, the system can access data stores 3005 storing the machine data and relate returned machine data (e.g., relate the machine data as being associated with respective entities). For example, the data stores 3005 can be oracle databases, MySQL databases, field-searchable data stores, and so on. Optionally, the system may generate one or more database tables for each entity identified in the returned machine data. For example, as a particular user is identified in returned machine data (e.g., associated with completion of a step), the system can generate a database table that records information included in the machine data. With respect to this example, if subsequent machine data identifies the particular user (e.g., associated with completion of a different step) is returned, the system can update the generated database table to record information included in the subsequent machine data. In this way, the system can maintain each entity's status with respect to the user journey. Optionally, the system can maintain a database table associated with each step, and can record (e.g., in respective

rows) information included in machine data returned as a result of executing search queries corresponding to the step.

[0484] With respect to the nested user journey that includes sub-steps A-N, the system can relate machine data returned as a result of executing the search queries corresponding to the sub-steps. Optionally, if all of the sub-steps are indicated as being completed for a particular entity, the system can store information indicating completion of the nested user journey. For example, the system can update a database table generated for the particular entity to indicate completion of the nested user journey. Optionally, if sub-step N is determined to be completed for the particular entity, the system can update the database table to indicate completion of the nested user journey. That is, the system may optionally assume that completion of the final sub-step indicates completion of the nested user journey. As described above, with respect to FIG. 28, steps included in a user journey may be defined without respect to order. As the system relates events or machine data, the system can identify a traversal order of the steps that each entity took. The system may therefore identify that sub-step N corresponds to a final step based on monitoring historical information associated with the nested user journey. For example, the system can determine that sub-step N corresponds to a final step. Additionally, and as described above with respect to FIG. 28, a user who creating the nested user journey may have specified that sub-step N corresponds to a final step. Therefore, the system can identify that machine data returned as a result of executing search queries corresponding to sub-step N, indicates completion of the nested user journey.

[0485] As described above with respect to FIG. 29, machine data associated with a same entity may include different identifying information. Therefore, the system can utilize one or more stitching schemes to stitch this machine data together. For example, first machine data may be returned as satisfying one or more search queries corresponding to a first step, and second machine data may be returned as satisfying search queries corresponding to a second step. As described above the first machine data and second machine data may include different values for respective fields associated with identification information. The system can utilize, for example, a database table specifying correlations between values of these respective fields to identify a particular entity that is associated with both the first and the second machine data. Optionally, a database table generated for this particular entity may be updated to include information from the first machine data and the second machine data.

[0486] At block 3006, the system causes display of at least a portion of the results. As described above, with respect to FIG. 29, the system can display results of the relating performed on the machine data. For example, the user interfaces described in FIGS. 31-36 can be examples of user interfaces presented in response to the relating.

[0487] FIG. 31 illustrates an example user interface 3100 that includes a user journey 3102 and information indicating clusters associated with the user journey. As described above, an entity may traverse through steps included in a user journey according to different paths. The system can monitor these different paths, and determine a frequency with which each of the paths is followed. Additionally, the system can determine a likelihood associated with an entity (e.g., user) following one of the paths.

[0488] As illustrated in FIG. 31, a user interface 3100 includes a user journey 3102 and steps of the user journey. As similarly described above with respect to FIG. 18, the user journey 3102 further illustrates a quantity of entities transitioning between each of the steps (e.g., as represented by visual elements 3106). On the right of the user interface 200 includes a clustering 2204 of entities along with a likelihood of any entity being included in the cluster (e.g., the likelihood can represent how common a particular path is). As described above, a cluster of entities can represent entities who traversed a same path through a user journey. As illustrated, a user of the user interface 3100 has selected the first two clusters, and in response the user interface 3100 can update the user journey 3102 to present information associated with entities of the first two clusters. For example, a quantity of the entities traversing the user journey can be presented. Additionally, an average time for transitioning between each step can be presented, with the average time being determined based on entities included in the selected clusters 3104.

[0489] Optionally, the user journey 3102 presented in user interface 3100 may include only steps that were traversed by entities included in the selected clusters 3104. For example, the presented steps may have been determined (e.g., by the data intake and query system 108) to be included in paths traversed by the entities included in the selected clusters 3104. If a user of the user interface 3100 selects one or more additional clusters (e.g., cluster 3), the user interface 3100 may update to present one or more additional steps traversed by entities in the additional clusters.

[0490] FIG. 32 illustrates an example user interface 3200 presenting summary information associated with a user journey. Based on executing queries and relating returned events, for example as described above with respect to FIG. 29, the data intake and query system 108 can determine summary information associated with each user journey. As illustrated, the system 108 has determined an average number 3202 of entities (e.g., users) who are traversing an example user journey per day. The user interface 3200 also includes statistical information related to the user journey. For example, the statistical information includes an indication of an empirically determined initial step 3204 in the user journey. Additionally, the statistical information indicates a percentage 3206 of entities who completed at least one step of the user journey, but who have since dropped out from the user journey. Major steps 3208 are illustrated, which as described above with respect to FIG. 18, can represent milestones that are to be depicted on a graphical representation of the user journey or optionally a step that is a nested user journey. Additional steps may be included between the major steps 3208.

[0491] User interface 3200 further includes a number of policy violations 3210 (e.g., "18" violations in the example). A user (e.g., a user creating the user journey) can specify particular constraints or potential occurrences that are to be monitored, and if detected, are to be indicated as a policy violation. For example, a policy violation can represent a particular step taking longer than a set amount of time to complete, or a transition between two steps (e.g., completion of both steps) taking longer than a set amount of time. As another example, a policy violation can represent a user following a particular path (e.g., a user completing a first step and then completing a second step, which this order being disfavored or other thought to be disallowed).

[0492] FIG. 33 illustrates another example user interface 3300 presenting summary information associated with a user journey. The user interface 3300 indicates real-time information associated with the user journey. For example, the user interface 3300 presents a count 3302 associated with entities traversing the user journey, along with a count associated with entities in each event. For example, to identify a count of users in a step, the data intake and query system 108 can obtain indication of a last known step for the users. Additionally, user interface 3300 includes average wait times 3304 of the user journey. As an example, a wait time 3304 can indicate an amount of time subsequent to completion of a step, that completion of a subsequent step is detected. Additionally, the user interface 3300 indicates a throughput 3306 associated with each step, with the throughput representing a number of users completing the step per unit of time (e.g., hour).

[0493] FIG. 34 illustrates an example user interface 3400 presenting a nested user journey 3404 included in a user journey 3402. As described above, a step of a user journey can include sub-steps, with the sub-steps defining a nested user journey. Nested user journeys can enable the rapid creation of user journeys through re-use of previously created user journeys. That is, a user of the data intake and query system 108 can utilize previously created steps, user journeys, and so on, as building blocks to create a new user journey.

[0494] As illustrated in FIG. 34, a user journey 3402 that includes steps is presented. Each of the steps is presented along a horizontal line representing the user journey 3402. The user interface 3405 can respond to selections of steps, and present detailed information related to the step. For example, upon selection of step 3406A, the user interface 3400 can update to indicate a time at which an entity (e.g., user 'Tula') completed the step 3406A. Additionally, the user interface 3400 can present an event or other information that was returned as a result of execution of one or more search queries corresponding to the step 3406A, or the information from the event that was stored per the user journey.

[0495] In the example of FIG. 34, a user of user interface 3400 has selected step 3406B. Upon selection, the user interface 3400 has updated to indicate the sub-steps 3408A-C included in the step 3406B. That is, step 3406B is illustrated as being a nested user journey 3404. Times at which the entity completed the sub-steps of the nested user journey 3404 are specified in user interface 3400. As described above, each of the steps shown can correspond to one or more events that were identified as a result of the system 108 executing a query. Similarly, each of the displayed steps of the journey can correspond to one or more events that were identified as a result of the system 108 executing a query.

[0496] User interface 3400 further indicates an ID 3410, which can represent a unique identifier associated with a user journey. As described above, different versions of a user journey can be created, and results from each version can be analyzed. Additionally, each user journey may be associated with a unique identifier such that it can be monitored by the data intake and query system 108. An entity 3412 is identified (e.g., user 'Tula Otten'), along with a start step 3414 and end step 3416. The start step 3414 can represent an initial step satisfied by the entity 3412, and the end step 3416 can represent a final step completed by the entity. Addition-

ally, an average time gap **3420** can be determined (e.g., an average time between completion of the steps), along with a longest gap.

[0497] FIG. 35 illustrates an example user interface **3500** indicating a path **3504** a particular entity **3502** took through steps included in a user journey, which may also be referred to herein as a journey instance. As illustrated, steps of a user journey are presented, along with indications of a time the entity **3502** took to transition between the steps. The illustrated steps represent the particular steps that the entity **3502** completed. That is, in contrast to FIG. 18 which illustrates all paths traversed by any entity for a user journey, FIG. 35 presents the specific path **3504** that entity **3502** traversed through the user journey. This path **3504** is indicated in user interface **3500**, as per the path frequency **3506** portion, as having been traversed by a particular number of all users (e.g., 25% of users). A user of the user interface **3500** can search for a particular entity, and the data intake and query system **108** can analyze its related event information (e.g., as described in, at least, FIG. 29) to present a path traversed by the searched entity.

[0498] FIG. 36 illustrates an example user interface **3600** presenting touchpoints **3602** associated with a particular entity **3604**. As described above, each step may represent a particular touchpoint of an entity with respect to disparate computing systems. For example, the touchpoint can represent a user interaction being recorded by a computing system. A timeline of touchpoints can be generated by the data intake and query system **108**, for example touchpoints across user journeys.

[0499] As illustrated, touchpoints **3602** of a particular entity **3604** are presented. These touchpoints **3602** are based on a total number of user journeys associated with the particular entity **3602** (e.g., **145** user journeys). For example, the total number can include user journeys started (e.g., the particular entity **3604** satisfied at least one step), or include user journeys completed (e.g., the particular entity **3604** completed a final step, for example as described in FIG. 28). As described above, with respect to FIG. 29, particular touchpoints (e.g., user interactions) can be specified to be monitored by the data intake and query system **108**. In this way, a timeline of the specified touchpoints can be presented.

[0500] In the example of FIG. 36, touchpoints **3602** are specified along with particular times **3606** at which the touchpoints were recorded. For example, user interface **3600** presents a visual element **3608** as representing a recorded touchpoint. A user of user interface **3600** can select the visual element **3608**, and the user interface **3600** can update to specify detailed information related to this touchpoint. For example, the user interface **3600** can present a time at which the touchpoint was recorded (e.g., an event including information related to this touchpoint can be presented).

[0501] Journey Instances and Models

[0502] As described herein, a computing system can generate machine data in response to touchpoints or interactions that it has with users, other computing systems, or other entities. The machine data may include information indicative of a particular user (or system) interacting with the computing system, along with further information describing the interaction. Furthermore, the interaction with the computing system can trigger that computing system to interact with another computing system, which may generate its own set of machine data in response.

[0503] The machine data generated by various computing systems can be ingested, for example by the data intake and query system **108**, which can produce events based on the machine data. The events can be utilized to provide insight into the complex computing system environments. For example, the events can be accessibly maintained in data stores, and queries identifying a set of data and a manner of processing the data can be executed. In this way, the machine data can be investigated (e.g., poked) via differing queries, field definitions updated, and so on, to identify useful information related to the computing systems and users.

[0504] In some cases, multiple interactions with one or more computing systems, and the machine data generated in response thereto, can be related. For example, during a single session of a user, multiple events can be generated that each relate to the user or session. In some cases, these events can be generated by one computing system or by multiple similar or heterogeneous computing systems.

[0505] A combination of these related interactions and associated machine data (or events) may be referred to herein as a journey instance. Thus, a journey instance can include one or more events or step instances that relate to a particular user, session, entity, or the like. Further, the events or step instances of the journey instance can be generated by the same or different data sources or computing systems and have the same or heterogeneous data formats. Therefore, a journey instance can indicate occurrences of events across one or more disparate data sources or data systems. This includes occurrences of events across heterogeneous data sources and/or heterogeneous data systems.

[0506] A journey instance can provide useful information related to the functioning and operation of the one or more computing systems. For example, a journey instance can provide useful information regarding how a user, system, or other entity interacts with, e.g., “contacts” or “touches,” a computer system or set of computer systems. In addition, in some cases, a journey instance may help form a picture of a particular user’s utilization of a user account or interaction with various computer systems associated with the user account. Furthermore, multiple journey instances (e.g., multiple groupings of related events or machine data), may help form a picture of the system’s utilization rate, efficiency, or help identify the cause of an error. In addition, multiple journey instances can form a picture of common interactions (and a sequence of those actions) that a computing system has with users. For example, multiple journey instances may be used to determine the most common, relatively, interactions (and a sequence of those actions), or to determine interactions that happen infrequently. In various implementations, journey instances may include information regarding time spent interacting with various computer systems.

[0507] In some cases, multiple journey instances can be used to generate a journey model. For example, in some cases, the system **108** can combine multiple journey instances to generate the journey model. The journey model can include steps that correspond to all, or a subset, of the step instances (which may be ordered temporally or otherwise) found within any one of the journey instances and can indicate the various paths that the journey instances take through the steps. Thus, while a single journey instance can indicate a particular path through a particular group of steps (based on the step instances of the journey instance), which may not be all of the steps in a set of data, the journey model

can, in some embodiments, indicate the various paths taken through any step found within the set of data. Further, the system 108 can generate multiple journey models depending on the journey instances being analyzed. In some cases, the system 108 can generate a first or primary journey model that corresponds to all of the journey instances generated from a set of data. The system 108 can generate additional journey models based on a user filtering or identifying a subset of the journey instances for review.

[0508] Moreover, where a journey instance can include a particular sequence of step instances related together based on a pivot ID, user, or entity, a journey model can include a particular number of steps (ordered or unordered) without relation to a particular pivot ID, user, or entity. In this way, a journey instance can be an instance, representation, or example of a journey model, and a step instance can be an instance, representation, or example of a step of the journey model.

[0509] In certain embodiments, a journey model can be generated by identifying one or more related steps or events with or without combining journey instances. In some cases, a user can identify certain events as steps within a journey model and/or identify certain values within events as indications of a step within a journey model. For example, a user can identify a field associated with events as a step identifier and identify each unique field value (or a selected subset of the field values) of the identified field as a step in a journey model. Similarly, if multiple fields are identified as step identifiers (across one or more data sources), the unique field values across the identified fields (or a selected subset of the field values) can be identified as steps in the journey model. In addition, in certain cases, a user may specify a preferred or expected order of the steps, which can be used to order the steps of the journey model. In some cases, one or more journey instances can be used to determine the order of steps of a journey model. Accordingly, in some embodiments, a journey model can include an ordered or unordered set of steps. Thus, the journey models can be ordered journey models or unordered journey models. The ordered journey models can include a set of steps ordered in a particular way. The unordered journey models can include a set of steps, but may not include a particular order for the steps.

[0510] As will be appreciated by one of skill in the art in light of the description above, the embodiments disclosed herein substantially increase the ability of computing systems, such as the data intake and query system, to process related data from one or more disparate data sources or computing systems that generate heterogeneous machine data. Specifically, the embodiments disclosed herein enable the data intake and query system to parse heterogeneous machine data across disparate computing systems to identify and group related events and to generate visualizations of the related machine data to facilitate understanding of the system topology and the interactions with and between disparate computing systems. The aforementioned features enable the system to reduce the computing resources used to correlate heterogeneous data across disparate computing systems. Thus, the presently disclosed embodiments represent an improvement in the functioning of such data intake and query systems. Moreover, the presently disclosed embodiments address technical problems inherent within computing systems; specifically, the limited capacity of computing systems to parse and correlate machine data from one or more disparate computing systems, as well as the

limited ability of such systems to generate visualizations of correlated data in a manner that facilitates the understanding of the underlying computing topology and interactions between and with disparate computing systems. These technical problems are addressed by the various technical solutions described herein, including the utilization of particular data structures and computing resources to identify related data across one or more disparate computing systems and particular data structures to indicate the relationship of the data. Thus, the present application represents a substantial improvement on existing data intake and query systems and computing systems in general.

[0511] Non-limiting examples of visualizations of multiple subsets of events, multiple journey instances, clusters of journey instances, or one or more journey models are shown at least in FIGS. 18, 31, 39A, 39B, 40A, 40B, and 41. Further, as a non-limiting example, a visualization of subsets of events or a journey instance, such as the visualization of a journey instance in FIG. 35, can be similar to the visualization of a journey model, but in some cases, may only show the steps and paths between steps associated with a particular user, entity, session, etc. The ability to analyze and relate individual events to generate journey instances or journey models facilitates the understanding of the complex interactions that take place across one or more computing systems, and allows visualization, analysis, and/or inferences from the journey instances and/or the data underlying the journey instances.

[0512] While identifying related data can be helpful, it can be difficult to do given the large amounts of data ingested by the data intake and query system. This can be further complicated when the related data is located across disparate data sources that store heterogeneous data. Thus, as will be discussed in more detail herein, various embodiments allow identification of related data, including in systems in which large amounts of data are ingested and/or when the related data is located across multiple or disparate data sources that may store heterogeneous data.

4.1 User Interface Overview

[0513] FIGS. 37A and 37B illustrate an example user interface for identifying one or more pivot identifiers and one or more step identifiers that can be used to identify related data (e.g., events) from a set of data and to form journey instances and/or journey models. The set of data can correspond to data identified by selecting one or more data sources and/or by executing a query.

[0514] In the illustrated embodiment, the user interface 3700 includes interface control objects 3701A-3701C, a data source section 3702, a field identifier section 3704, and a field value preview section 3706. It will be understood that the interface 3700 can include fewer or more sections, display objects, features, etc.

[0515] The interface control objects 3701A-3701C, can be used to select various portions of the user interface 3704 for display. For example, the search interface control object 3701A can be used to select an interface that includes a search bar for entering a query. Similarly, the sessionization interface control object 3701C can be used to select an interface that includes sections to indicate a time period or time constraints for the query, or for the events that can satisfy the query, or other constraints or conditions regarding the query. In the illustrated embodiment, the field mapping interface control object 3701B is selected. Based on the

selection of the field mapping interface control object 3701B, the interface 3700 displays the field identifier section 3704 and the field value preview section 3706.

[0516] The data source section 3702 can be used to select a data source for review. In some embodiments, the data source section 3702 can identify the data sources or data streams corresponding to the data that satisfies a query. For example, if the query indicates that the set of data to be processed corresponds to all data from a particular index, the data source section 3702 can identify each data source corresponding to the events in the particular index. In certain embodiments, the data source section 3702 can correspond to the data sources managed by the user or the data sources selected for review as part of generating the journey instances and/or journey models. In the illustrated, the data source Buttercup Games is selected. The data source section 3702 may allow the user to add additional data sources for review, or, in other implementations, the data source section 3702 may be populated automatically through various predetermined settings, configurations and configuration files, etc.

4.1.1 Displaying Field Identifiers

[0517] Based on a query and or a selection of a particular data source, the data intake and query system 108 can identify and display in the field identifier section 3704 the field identifiers of events from the particular data source or that satisfy the query. In some cases, to identify the field identifiers to be displayed in the field identifier section 3704, the data intake and query system 108 can consult one or more configuration files. As described in greater detail above, the data intake and query system 108 can include one or more configuration files for each data source that provides data to the data intake and query system 108. The configuration files can include field identifiers for the data received by the data intake and query system 108 from the data source. Furthermore, the configuration files can include one or more field definitions or regex rules to extract field values corresponding to the field identifiers. For example, the data intake and query system 108 can include a configuration file that includes some or all of the field identifiers for data that the data intake and query system 108 has received from the data source Buttercup Games, as well as field definitions for extracting field values corresponding to the field identifiers found in data received from the data source Buttercup Games. In other implementations, the field identifiers may be obtained using other techniques, including user input, machine-learning inferences about field identifiers, or other field identification techniques described in this and the incorporated applications.

[0518] In the illustrated embodiment, the data intake and query system 108 has identified and displays in the field identifier section 3704 a number of field identifiers corresponding to the data source Buttercup Games. For example, the data intake and query system 108 has determined that data from the data source Buttercup Games includes the fields: "ident," "items," "JSESSIONID," "method," "msg," "other," "product," "productid," "q," etc. As mentioned above, in some embodiments, the data intake and query system 108 can identify the aforementioned fields by consulting a configuration file that corresponds to the data source Buttercup Games. In certain embodiments, the data intake and query system 108 can identify the aforementioned fields based on user input, machine learning, extract-

ing the fields from the set of data, using a lookup table or other system resource that indicates fields for a particular set of data, etc.

[0519] In some cases, the field identifiers shown in the field identifier section 3704 can correspond to field identifiers of the data that satisfies a query. As mentioned above, a query can be used to identify a set of data to be processed. In some cases, the identified set of data can correspond to data from one or more data sources. The data intake and query system 108 can analyze the set of data (e.g., a group of events) that satisfies the query to identify field identifiers to display in the field identifier section 3704. In some cases, the data intake and query system 108 can use one or more configuration files to identify the field identifiers corresponding to the data that satisfies the query. Accordingly, in some embodiments, the fields "ident," "items," "JSESSIONID," "method," "msg," "other," "product," "productid," "q," can correspond to fields associated with data from multiple data sources.

[0520] Upon selection of a field identifier, the user interface 3700 can display, in the field value preview section 3706, one or more field values corresponding to the selected field identifier. In certain embodiments, the data intake and query system 108 determines that a field identifier has been selected based on user interaction with the field identifier, such as, but not limited to, hovering over, pointing to, clicking on, etc.

[0521] In the illustrated embodiment of FIG. 37A, based on a selection of the field identifier "JSESSIONID," the user interface 3700 populates the field value preview section 3706 with a list of field values for the field "JSESSIONID." In addition, the field value preview section 3706 includes a count of each displayed field value for the field "JSESSIONID," identifying the number of unique events that include the particular field value or the number of instances of the particular field value across the set of data. Similarly, in the illustrated embodiment of FIG. 37B, based on selection of the field identifier "action," the user interface 3700 populates the field value preview section 3706 with a list of field values for the field "action."

[0522] In some embodiments, the system 108 can consult one or more inverted indexes, as described in greater detail above with reference to at least FIG. 5B, to populate the field value preview section 3706 with field values and counts. For example, once a field identifier is selected from the field identifier section 3704, the system 108 can identify one or more inverted indexes (e.g., inverted index 507B) that include a field-value pair 513A that includes the selected field identifier as the field portion of the field-value pair 513A. Once the appropriate inverted index(es) is identified, the system 108 can identify the unique field values that correspond to the identified field based on the field-value pairs 513A. The identified unique field values identified from the inverted index can be displayed as the field values in the field value preview section 3706. Further, the system 108 can determine the count for the field values in the field value preview section 3706 using the inverted index(es). For example, as each field-value pair entry 513 identifies events with the field-value pair 513A, the system 108 can sum the number of events for each field-value pair entry 513 to identify the count value for each field value in the field value preview section 3706. In other implementations, the system 108 can identify the field values based on an analysis of the events (e.g., extracting field values from the events) or a

subset of the events (e.g., the first 1,000 events of a set of data), pre-processing the set of data, etc. In some embodiments, as the system 108 obtains the field values it can dynamically update the field value preview section 3706. For example the field values or counts in the field value preview section 3706 can be updated as the system 108 parses the events, inverted or keyword indexes, etc.

[0523] 4.1.2 Selecting Pivot Identifiers and Step Identifiers

[0524] In addition to displaying field identifiers in the field identifier section 3704, the user interface 3700 can enable a user to identify one or more pivot IDs, one or more step IDs, one or more attributes, etc. This can be done in a variety of ways, including, but not limited to, drop-down menus, text boxes, checks boxes, fields, etc. In the illustrated embodiments of FIGS. 37A and 37B, the user interface 3700 includes a drop-down menu 3708 that enables a user to identify a particular field identifier as an attribute, pivot ID, or a step ID. In the illustrated embodiment of FIG. 37A, the user has selected the field “JSESSIONID” and is determining whether to make the field “JSESSIONID” an attribute, pivot ID, or step ID. In the illustrated embodiment of FIG. 37B, it is shown that the user selected “JSESSIONID” as a pivot ID and is determining whether to identify “action” as an attribute, pivot ID, or step ID. With reference to the FIGS. 38-42, it will be under that “action” is selected as a step ID.

[0525] The selection status indicators 3710A-3710C, can be used to indicate whether and how many step IDs, pivot IDs, and attributes have been selected. In the illustrated embodiment of FIG. 37A, no step IDs, pivot IDs, or attributes have been selected. However, in the illustrated embodiment of FIG. 37B, one pivot ID has been selected as indicated by the pivot ID selection status indicator 3710B. Further, as shown in the FIG. 37B, the field “JSESSIONID” has been selected as the pivot ID.

[0526] As mentioned above, in some embodiments, the field identifiers displayed in the field identifier section 3704 can correspond to all of the field identifiers associated with the events in the set of data or can correspond to the field identifiers associated with the events from a one or more data sources associated with the set of data, such as the data source “Buttercup Games” as illustrated in FIGS. 37A and 37B. In embodiments where the field identifier section 3704 includes field identifiers associated with a single data source, the user interface 3700 can enable a user to select other data sources so that one or more step identifiers, pivot identifiers, and attributes, can be selected for the other data sources. For example, with reference to the illustrated embodiment of FIG. 37A, a user can select the data source “Sales Email.” In response, the field identifier section 3704 can be updated to show field identifiers corresponding to data from the data source “Sales Email.” As such, a user can use the updated field identifier section 3704 to identify one or more fields for events from the data source “Sales Email” as a pivot ID, step ID, or attribute. This process can be repeated for as many data sources that correspond to data that satisfies the query or that is part of the set of data to be used to generate the journey instances or journey models.

[0527] In embodiments, where field identifiers displayed in the field identifier section 3704 correspond to all of the field identifiers associated with the events in the set of data, the user interface 3700 can enable a user to identify one or more fields as one or more step identifiers, one or more pivot identifiers, or one or more attributes. In certain embodi-

ments, a single step ID can be selected for all data sources associated with events that satisfy the query. For example, certain fields within each data source can be associated with a universal field, and that field can be identified as the step ID.

[0528] Using one or more pivot IDs and one or more step IDs, the data intake and query system 108 can parse the set of data, or events, to identify one or more journey instances and journey models, as well as identify particular steps within the journey instances and journey models. Further, the data intake and query system 108 can display visualizations corresponding to the journey instances and journey models.

4.2 Pivot Identifiers

[0529] In some embodiments, the data intake and query system uses one or more pivot IDs to identify related events from the set of data and/or to create journey instances. In some embodiments, the data intake and query system 108 can identify related events and/or generate journey instances based on field values associated with the pivot identifier. For example, the data intake and query system 108 can identify the events from a data source that include the same field value for the field associated with the pivot ID (also referred to as the pivot ID field). The system 108 can then associate the identified events as part of a journey instance. For example, with reference to FIG. 37A, the events from the data source Buttercup Games with a field value of “SD5SLFF8ADFF4961” for the “JSESSIONID” field can be grouped as a set of events associated together as part of a journey instance. Further, the data intake and query system can generate a journey instance for each of the unique field values identified in the field value preview section 3706, which would result in at least 13 distinct journey instances.

[0530] In some embodiments, the user interface 3700 can enable an identification of a subset of the field values in the field value preview section 3706 as field values for the pivot ID. In some cases, the system can ignore deselected field values and not use them to relate events, build sets of events, or generate journey instances or journey models. For example, the user interface 3700 can include checkboxes or some other indicator to enable a user to deselect “SD5SLFF8ADFF4961” (or any other field value). Based on the deselection, the system 108 can ignore, discard, or not use events with the field value “SD5SLFF8ADFF4961” to build sets of events, journey instances, journey models, etc.

[0531] In embodiments where events from multiple data sources are to be associated together as part of a single journey instance, the data intake and query system 108 can identify a relationship between a unique field value of a field in a first data source with a unique field value of a field in a second data source. Once the relationship between the two unique field values from different data sources is identified, the data intake and query system 108 can associate the events from the first data source that have the first unique field value with the events from the second data source with the second unique field value.

[0532] Accordingly, in certain embodiments, the data intake and query system 108 can identify a journey instance for unique combinations of related field values across different data sources. As a non-limiting example, suppose events with the information identified in Table 1 are related.

TABLE 1

Field Value	Pivot ID Field	Data Source
SD5SL5FF8ADFF4961	JSESSIONID	Buttercup Games
X12245YZ	sess_ID	Sales Email
6812-TUXKE1	user_ID	Order Process Flow

[0533] Based on an identified relationship between the field values identified in Table 1, the data intake and query system **108** can generate a journey instance that includes all events from Buttercup Games that include the field value “SD5SL5FF8ADFF4961” for the field “JSESSIONID,” all events from Sales Email that include the field value “X12245YZ” for the field sess_ID, and all events from Order Process Flow that include the field value “6812-TUXKE1” for the field user_ID. In an implementation, the identified pivot ID or pivot IDs will be used to facilitate determination of relationships between field values. Specifically, in an implementation, identified pivot ID fields will be examined for field values that can be used to cross-correlate events across disparate data sets. It will be understood that the data intake and query system **108** can use a variety of techniques to generate journey instances. For example, in some embodiments, based on the Table 1 above, the data intake and query system can generate a journey instance that includes all events from any one of the data sources that includes any one of the identified field values.

[0534] By identifying intra-data source related events and inter-data source related events, the data intake and query system **108** can generate a journey instance that includes related events across one or more data sources. In some embodiments, the data intake and query system **108** identifies intra-data source related events and inter-data source related events concurrently. In certain embodiments, the data intake and query system identifies intra-data source related events before or after inter-data source related events.

[0535] As a non-limiting example and with reference to table above, the data intake and query system **108** can first separately identify the events from the data source Buttercup Games with the field value “SD5SL5FF8ADFF4961” and the events from the data source Sales Email that include the field value “X12245YZ” before interrelating the events from the data source Buttercup Games and the data source Sales Email. Alternatively, the data intake and query system **108** can concurrently identify and relate events from the same data source and from multiple data sources.

[0536] 4.2.1 Gluing Events

[0537] In some embodiments, the data intake and query system **108** can identify a relationship between two unique field values of events from different data sources based on a gluing event that includes both field values within the event. In some cases, when one computing system interacts with another computing system, one or both computing systems generate an event that includes an identifier from both computing systems. For example, if a first data source that includes a value of “1234” for a field “cust_ID” interacts with a second data source, the second data source may include an event with the value “1234,” as well as the value “ABC” for a “trackID” field. Further, the value “ABC” for the “trackID” field may be found in each event of the second data source that relate to the same user or session, and the value “1234” for the “cust_ID” field may be found in each events of the first data source that relate to the same user or session.

[0538] Accordingly, the system **108** can identify the event in the second data source that includes the value “ABC” for the “trackID” field, as well as the value “1234.” Based on the identification of this “gluing event,” the system **108** can determine that events with the value “1234” for the field “cust_ID” from the first data source are related to events with the value “ABC” for the field “trackID” from the second data source. Based on this relationship, the system **108** can generate a journey instance that includes events or steps across data sources, e.g., multiple or disparate data sources. Moreover, there may be multiple gluing events within a particular data source, which would allow data sources having no fields in common to be connected, provided that an intermediate data source (or intermediate data sources) including gluing events that linked to each of the data sources to be logically connected and searched. Further, the system **108** can use gluing events within a particular data source to identify primary and nested journey instances. For example, events in a primary journey instance can be associated based on a first pivot ID and events in a related nested journey instance can be identified based on a second pivot ID. Specifically, a first data source could share a gluing event with a second data source, and the second data source could share a gluing event with a third data source. The first data source and the third data source could then be linked and searched together, despite having no fields in common (or no fields in common capable of linking the two data sources).

[0539] In certain cases, to identify the gluing event, the system **108** can identify the field value for a pivot ID field in a first data source and then perform a search for that field value among the events from the second data source. In some embodiments, the search can be performed by analyzing the machine data of each event and/or by analyzing an inverted index or keyword index, as described herein. In embodiments where an inverted or keyword index is searched, in some cases, the system **108** can identify a field-value pair entry that includes the searched for value as the field value portion of the field-value pair or identify a token entry that includes the searched for value as a token or keyword. It will be understood that the system **108** can identify and/or search the inverted or keyword index in a variety of ways. For example, the system **108** can search for the searched for value in any location of an inverted or keyword index.

[0540] With reference to the example above, if the “cust_ID” field is identified as the pivot ID field for the first data source with a field value of “1234,” the system **108** can perform a search on the events from the second data source to identify any events with the value “1234” located within the data of the event. As mentioned, the search can include a review of the data (e.g., machine data) of each event from the second data source and/or a review of an inverted or keyword index that corresponds to the events from the second data source. With reference to searching an inverted or keyword index, the system **108** can identify an inverted or keyword index that includes information about the events from the second data source, and then identify a field-value pair entry or token entry in the inverted/keyword index that includes the value “1234.” For the field-value pair entry, the system **108** can review the value portion of a field-value pair for the value “1234.” For the keyword entry, the system **108** can review the keyword portion of the keyword entry for the value “1234.”

[0541] The identified event(s) can be used to link the value “1234” to the field value of the pivot ID field for the second data source. Once the two field values are linked, the system 108 can relate events with either field value as part of the same journey instance.

[0542] In some embodiments, when searching for a gluing event, the system 108 can limit the search to events from the second data source that include the pivot ID field for the second data source. In this way, the system 108 can exclude events from the second data source that will not have a field value that can be linked with the field value from the first data source. With reference to the example above, the system 108 can exclude from the search events from the second data source that will not have a field value that can be linked with the field value “1234” from the first data source.

[0543] In some cases, the system 108 can identify a field in one or more events from the second data source that includes the field value from the first data source. Such a field may be referred to as a linking field. For example, one or more events in the second data source may have the field value from a different computing system identified in a field “previousID.” Based on an identification of the linking field in the events from the second data source, the system 108 can tune its search for events in the second data source with a field value that matches the field value from the first data source to events from the second data source that include the identified linking field.

[0544] With continued reference to the above example, once the system 108 identifies the previousID field, it can narrow its search to those events that include a field “previousID.” In this way, rather than searching across all events from the second data source for the field value “1234,” the system 108 can limit its search to a subset of the events from the second data source (e.g., those events in the second data source that include a field “previousID”). By targeting the search in this way, the system 108 can reduce the processing overhead used to identify a gluing event.

[0545] Further, if using an inverted or keyword index to identify gluing events, the system 108 can focus or narrow its search to field-value pair entries that include the identified linking field as the field portion of a field-value pair. With reference to the example, the system 108 can tailor its search in the inverted or keyword index to field-value pair entries that include previousID as the field portion of the field-value pair.

[0546] In some cases, the system 108 can suggest certain fields as potential linking fields to the user. For example, the system can suggest to a user that fields with certain names or frequency may be useful as linking fields. For example, fields like “previousID,” “prevID,” “oldSession,” etc. may be suggested as they may be linking fields. The system 108 can obtain the list of fields using a configuration file or inverted or keyword index, as described herein. Similarly, the system 108 can identify a particular event, such as an earliest-in-time event for a journey instance, or set of related events potential gluing event(s). The fields from the potential gluing events can be suggested to a user as potential linking fields. In other implementations, machine learning techniques, e.g., training on known data sources with similarities to the data sources that are the subject of the instant search, may be used to suggest potential gluing events.

[0547] 4.3 Step Identifiers

[0548] In certain embodiments, the data intake and query system 108 uses the one or more step IDs to identify events that correspond to steps, order individual journey instances, and/or generate journey models. In some embodiments, each unique field value, or a subset thereof, for a field identified as the step ID (also referred to as a step ID field) corresponds to a step in a journey instance or journey model. Accordingly, based on the field value for the step ID field, the system 108 can determine the step to which a particular event belongs. For example, if the event includes the field value “purchase” for the step ID field “action,” the system 108 can determine that the event is a “purchase” step.

[0549] In some cases, the data intake and query system 108 can parse journey instances using the step ID to identify the individual steps within the journey instance. For example, with reference to FIG. 37B, once a particular journey instance is identified, the data intake and query system can use the field values “purchase,” “addtocart,” “view,” “changequantity,” and “remove,” (field values of the step ID field “action”) to identify individual steps within the journey instance. In some cases, the journey instance may include each of the unique field values of the step ID field, multiple instances of one or more of the field values of the step ID field, or a subset of the field values of the step ID field. For example, with continued reference to FIG. 37B, a journey instance can include zero, one, or more “purchase,” “addtocart,” “view,” “changequantity,” or “remove,” steps.

[0550] In some embodiments, the user interface 3700 can enable an identification of a subset of the field values in the field value preview section 3706 as field values for the step ID. In some cases, the system can ignore deselected field values and not use them to identify steps, categorize events, build subsets of events, or generate journey instances or journey models. For example, the user interface 3700 can include checkboxes or some other indicator to enable a user to deselect “addtocart” (or any other field value) Based on the deselection, the system 108 can ignore, discard, or not use events with the field value “addtocart” to build subsets of events journey instances, journey models, etc.

[0551] In some embodiments, multiple step IDs can be used to categorize events or build subsets of events. For example, as described herein, one step ID can be selected for one data source and a second step ID can be selected for another data source. Each step ID can identify a particular field in the data source as the step ID field.

[0552] Further, in some embodiments, the system can use a second step ID to categorize events in nested journey instances, which can be located in the same or a different data source as each other or as the events in the primary journey instance. In some cases, the nested journey instances can have a field value for a step ID field for a primary journey instance and a field value for a step ID field for the nested journey instance. In cases, where the events in the journey instance have a field value for the parent primary journey instance, the field values may be the same (indicating they are all part of the same step) or different.

[0553] Moreover, in certain embodiments, multiple events (or a subset of events) can correspond to a single step instance. For example, the system 108 can determine that to satisfy the “addtocart” step or step instance, three events need to occur. As such, the system 108 can identify the three events that make up the “addtocart” step. Based on an occurrence of the three events (ordered or unordered), the system 108 can determine that the “addtocart” step has

occurred. In such embodiments, events that make up a step instance or subset of events can be categorized by one or more step IDs (e.g., can be categorized as part of the journey instance using one step ID and categorized between each other using a second step ID) and may or may not form part of a nested journey instance.

[0554] In some cases, the system 108 can exclude one or more events using the step ID. In some cases, if a particular event does not include a step ID (e.g., does not include the field identified by the step ID, does not include a field value corresponding to the field identified by the step ID, or includes an excluded field value for the step ID), the data intake and query system 108 can discard the particular event as not part of a journey instance. For example, a gluing event may include a field value for a pivot ID field, but may not include a field value for a step ID field. As such, it may be discarded from a journey instance (but still used by the system 108 to identify related events across different systems or related events from nested journey instances).

[0555] Furthermore, the step ID can be used to generate the journey model. For example, the field values (or a subset thereof) of the step ID field can be identified as steps within a journey model. In certain cases, some or all of the journey instances identified from the set of data can be used to form a journey model (e.g., by combining the journey instances or identifying journey model's step order from the journey instances). Thus, where a single journey instance may include a subset of the field values of the step ID field, a journey model can include all of the field values for the step ID field or all of the field values for the step ID field found within any single journey instance. Furthermore, the journey model can identify the different paths between its steps or the steps of the different journey instances.

[0556] In some embodiments, the data intake and query system can use a timestamp associated with each event or step to identify and order the steps of a journey instance. For example, based on a timestamp for a "view" step that is earlier in time than the timestamp for a "purchase" step, the system 108 can determine that the "view" step precedes the "purchase" step for the journey instance. If there are not intervening timestamps from related steps, the system 108 can determine that the "view" step immediately precedes the "purchase" step. In certain embodiments, such as when steps are taken in a particular order, the step ID can be used to identify the order. For example, if a "login" step is required before a "view" step, then the system 108 can determine the order of the steps based on their identification. In other implementations, the journey instance may be ordered using other techniques, such as analyzing the underlying data or metadata that makes up the steps of the journey instance.

[0557] In certain embodiments, the data intake and query system 108 can identify and order a journey instance without the use of a step ID. For example, the data intake and query system 108 can identify related events using one or more pivot IDs, and can order the related events as journey instances based on timestamps associated with the identified related events.

[0558] Although reference in the above examples is made to parsing journey instances/models to identify steps within them, it will be understood that the data intake and query system 108 can parse events to identify steps using one or more step IDs and then interrelate the steps into journey instances using one or more pivot IDs, or concurrently identify journey instances and steps. For example, it will be

understood that the one or more pivot IDs can be selected before, after, or concurrently with the one or more step IDs. In some embodiments, based on a selection of the one or more pivot IDs prior to one or more step IDs, the data intake and query system can identify journey instances from the events. Upon selection of one or more step of IDs, the data intake and query system 108 can then parse the journey instances to identify one or more steps within them. In certain embodiments, based on a selection of one or more step IDs prior to one or more pivot IDs, the data intake and query system 108 can identify events that correspond to steps. Upon selection of one or more pivot IDs, the data intake and query system can parse the events identified as steps to identify journey instances.

[0559] 4.4 Attributes

[0560] The attributes can be used to track, categorize, or group events, subsets of events, journey instances, or journey models. In some cases, when the user selects a field as an attribute, the system 108 can track the field values for the selected field as the system generate the journey instances or models. For example, with reference to FIG. 37A, if the field "method" is selected as an attribute and includes field values of "email," "phone," "SMS," "FTP," and "instant message," the system 108 can track which step instances or events in the journey instances include the different field values.

[0561] Using the field values of the attribute field, the system 108 can filter, group, sort, visualize, or otherwise manipulate the journey instances or models. For example, the system 108 can build one or more journey instances or journey models using only events that include the field value "SMS," or some other subset of field values, for the attribute field. Similarly, the system can build a journey model with journey instances that only include events with the field value "phone" for the attribute field or generate visualizations of journey instances that include an event with the field value "email" for the "method" field. As yet another example, the system can group or sort journey instances or journey models based on the field value for the attribute field. Thus, one or more fields identified as one or more attributes can enable the system to manipulate subsets of events, journey instances, or journey models in a variety of ways. In this way, the system 108 can facilitate the understanding of the machine data and the interactions within the computing system.

[0562] 4.5 Journey Summarization Overview

[0563] Based on the selection of one or more pivot IDs and one or more step IDs and the processing of the events of the set of data, the data intake and query system 108 can identify and organize journey instances. As discussed herein, in some embodiments, the data intake and query system 108 can identify a path through a journey instance based on timestamps associated with the events of the journey instance. For example, the data intake and query system 108 can order the step instances of the journey instance in chronological order and show paths between the step instances. As mentioned, in some cases, a journey instance may include multiple step instances of the same step (e.g., system recording that a user is interacting with a computer system in the same way multiple times, or is iteratively going through a set or subset of interactions with a computer system) or pass through each step instance of the journey instance once.

[0564] In some embodiments, the journey instances can be used to form a journey model. For example, a group of journey instances can be combined to form the journey

model. In some cases, some or all of the identified journey instances for a set of data can be combined to form the journey model. For example, the journey model may be based on only those journey instances that include a certain number of step instances or a particular order of step instances. In addition, the journey model can indicate the various pathways between its different steps as taken by the individual journey instances. Furthermore, the data intake and query system **108** can determine various analytics associated with the journey model, such as, but not limited to, common paths through the steps of the journey model, average time between each step, average length of time of a journey instance, most common steps in a journey, etc. The system **108** can display visualizations of the journey instances, journey models, and/or associated analytics to facilitate the understanding of relationships between events, data sources, and computing systems.

[0565] Using the pivot ID and step ID, the system **108** can more efficiently (e.g., using less computing resources) identify related events and an ordering of those events to generate or build journey instances or journey models. Using the journey instances and the journey model, the data intake and query system **108** can more efficiently identify relationships between events across one more heterogeneous data systems and facilitate the understanding of the complex interactions with the various data sources. Furthermore, based on the identification of the one or more pivot IDs in one or more step IDs, the data intake and query system can more efficiently process the events to identify related events and typical journeys through the related events.

[0566] FIG. **38** is a diagram illustrating an example user interface **3800** displaying an embodiment of a journey summarization. In the illustrated embodiment, the user interface **3800** includes a data source section **3702** and a journey overview section **3802**. The journey overview section **3802** can include analytics of the events, steps, one or more journey instances, or one or more journey models. For example, in the illustrated embodiment, the journey overview section **3802** includes a total journey instances section **3804**, total events section **3806**, timing parameters **3808A**, **3808B**, journey instance distributions graphic **3810**, and a step analytics section **3812**. It will be understood that the journey overview section **3802** can include fewer or more analytics and information associated with the events, journey instances, or journey model(s), as desired. For example, the user interface **3800** can include portions of events of one or more journey instances, identify common pathways through one or more journey models, etc.

[0567] The total journey instances section **3804** can indicate the total number of journey instances identified from the analyzed events or set of data. As discussed above, in some cases, the total number of journey instances can correspond to a total number of unique field values for a pivot ID field, or a total number of unique combinations of related field values for multiple pivot ID fields across one or more data sources.

[0568] The total events section **3806** can indicate the total number of events analyzed in order to form the journey instances. In some cases, all of the events can be included in a journey instance. However in certain cases some of the events may be excluded from a journey instance. For example, an event from a data source may not include a field identifier that corresponds to the selected pivot ID field(s) or step ID field(s), or may include a field value that was

excluded from a pivot ID field or step ID field. Such an event may not be included in a journey instance.

[0569] The timing parameters sections **3808A**, **3808B**, can indicate certain parameters used to identify journey instances. For example, with reference to FIG. **37A**, a user can select the sessionization interface control object **3701C** to identify time limits to identify journey instances or to identify one or more additional command or constraints for the set of data. Based on the indicated time limits, the data intake and query system **108** can determine when a journey instance is supposed to end. For example, in the illustrated embodiment of FIG. **38**, a max time limit of one hour has been set. Accordingly, in some cases, the data intake and query system **108** can determine that if two events include the same field value for the pivot ID field but are separated by more than one hour, then they correspond to different journey instances. In some cases, the data intake and query system **108** can use the timing parameters to determine when the journey instance has terminated. For example, if no event with a matching field value for a pivot ID field has a timestamp within one hour of the latest-in-time event of a journey instance (e.g., based on a timestamp associated with the events of the journey instance), then the data intake and query system **108** can determine that the identified latest-in-time event is the last event for the journey instance.

[0570] The journey instance length distribution graphic **3810** can be used to graphically illustrate the quantity of journey instances of a particular length or having a particular number of step instances. In some cases, the journey instance length distribution graphic **3810** can group journey instances with the same number of step instances together and display the number of journey instances with that particular number of step instances. For example, in the illustrated embodiment, the largest share of journey instances have one step instance and there are progressively fewer journey instances for each additional step instance (e.g., there are approximately 1,000 journey instances with two or three journey instances, approximately 550 journey instances with six step instances, etc.). It will be understood that additional graphics can be used to illustrate information about the journey instances, journey models, or events, as desired.

[0571] The step analytics section **3812** can identify the steps of one or more journey model or step instances of one or more journey instances as well as various analytics associated with each. In the illustrated embodiment, the step analytics section **3812** identifies a count, start percentage, and end percentage for each step. The count can correspond to the number of journey instances that include that a step instance that corresponds to the particular step and/or the number of instances of that step found within the events (e.g., one step may occur multiple times within a single journey instance). The start percentage and end percentage can indicate the percentage of journey instances that include a step instance that corresponds to that particular step as the first or last step (e.g., number of journey instances that include a step instance that corresponds to the step as the first or last step instance/the total number of journey instances), respectively, or the percentage of times that the particular step is the first or last step instance in a journey instance (e.g., the number of time that the step is found as the first or last step instance of a journey instance/the total number of instances of that step), respectively. It will be understood that fewer or more analytics can be displayed as

part of the step analytics section **3812**. For example, the steps analytics section **3812** can include information about common orders or relationships between steps, the number of instances of a particular order of steps, average time between steps, average time on a particular step, number of journey instances that started with a step instance that corresponds to that step, number of journey instances that ended with a step instance that corresponds to that step, number (and identification) of steps that occurred before or after that step for one or more journey instances, most/least common steps (and identification) that occurred before/after that step, number of journey instances that include a step instance that corresponds to that step more than once, number of journey instances that include a threshold number of step instances that correspond to that (or visited that step more or less than a particular number of times), number of journey instances that visited that include a step instance that corresponds to the step but does not include a step instance that corresponds to a particular different step, number of journey instances that include a step instance that corresponds to step directly before or after a particular step, any of the foregoing metrics applied to a number of journey instances or users that meet a particular attribute, etc.

4.5 Journey Visualizations

[0572] FIGS. **39A**, **39B**, **40A**, **40B**, **41**, and **42** are diagrams illustrating an example user interface **3900** displaying embodiments of journey summarizations, which can include, but are not limited to visualizations of events, subsets of events, journey instances, journey models, or a listing of related events, journey instances, or journey models. In the illustrated embodiments of FIGS. **39A**, **39B**, **40A**, **40B**, and **41** the journey summarization corresponds to a visualization of one or more journey instances, clusters of journey instances, or one or more journey models **3908**, **3910**, **4002**, **4006**, and **4102**, respectively. For simplicity, reference will be made to journey visualizations **3908**, **3910**, **4002**, **4006**, and **4102**. In the illustrated embodiments of FIG. **42**, the journey summarization corresponds to a listing of journey instances.

[0573] In the illustrated embodiments of FIGS. **39A**, **39B**, **40A**, **40B**, **41**, and **42**, the user interface **3900** includes a display area **3902**, summarization selection objects **3904A**, **3904B**, **3904C**, and control selection objects **3906A**, **3906B**, **3906C**, **3906D**. In certain embodiments, the user can navigate to the user interface **3900** by selecting the Explore display object **3814**, illustrated in FIG. **38**. However, it will be understood that a user can navigate to the user interface **3900** using a variety of methods.

[0574] The summarization selection objects **3904A**, **3904B**, **3904C** can be used to select a visualization for the summarization. Although only three summarization selection objects are shown, it will be understood that fewer or more summarization selection objects can be used to provide different visualizations for the summarization.

[0575] In certain embodiments, selection of the list summarization selection object **3904A** can result in the display of one or more lists of events, journey instances, or journey models. In some embodiments, selection of the flow chart summarization selection object **3904B**, can result in the display of one or more flow charts corresponding to one or more related events, journey instances, or journey models. Furthermore, in some cases, selection of the metrics summarization selection object **3904C** can result in the display

of a summarization that includes one or more metrics associated with the journey instances, events, or journey models generated by the data intake and query system **108**, such as but not limited to a completion rate (number of percentage of journey instances or models that started with a particular step instance or step and ended with a particular step instance or step), time to completion (average time of the journey instances that were completed, average time for all journey instance, or a subset, etc.), or other analytics described herein. Accordingly, the summarization selection objects **3904A-3904C** can be used to select various summarizations to aid a user in visualizing the journey instances or journey models generated from the events analyzed by the data intake and query system **108**.

[0576] With reference to the illustrated embodiments of FIGS. **39A**, **39B**, **40A**, **40B**, and **41**, the flowchart summarization selection object **3904B** is selected, which results in the display of the journey visualizations **3908**, **3910**, **4002**, **4006**, **4102**, respectively, in the display area **3902**. In the illustrated embodiment of FIG. **42**, the list summarization selection object **3904A** is selected, which results in the display of a listing of the journey instances in the display area **3902**.

[0577] 4.6.1 Control Selection

[0578] The control selection objects **3906A-3906D** can be used to select different controls for display in the summarization control area **3912**. The displayed controls can be used to modify the summarization displayed in the display area **3902**. Although only four control selection objects are shown, it will be understood that fewer or more control selection objects can be used to provide additional controls or to further modify the visualizations for the summarization.

[0579] In some embodiments, selection of the list steps control object **3906A** can result in the summarization control area **3912** displaying the steps identified in one or more journey instances or one or more journey models. In certain embodiments, selection of the filter control object **3906B** can result in the summarization control area **3912** displaying one or more controls that enable a user to set certain filters on the journey instances used to generate one or more journey models. In some cases, selection of the clustering control object **3906C** can result in the summarization control area **3912** displaying one or more controls that enable a user to view journey models formed from similar journey instances, such as journey instances that include the same steps and/or the same order of steps, etc., or to view clusters of journey instances. In certain cases, selection of the settings control object **3906D** can result in the summarization control area **3912** displaying one or more controls that enable a user to modify one or more settings of the journey instances, journey models, or data sources, whose events are used to generate the journey instances and models.

[0580] Using the controls displayed in the summarization control area **3912**, a user can manipulate the view of the various journey instances generated by the data intake and query system **108**. Further, based on the particular settings or controls selected from the summarization control area **3912**, the data intake and query system **108** can generate and display one or more journey visualizations based on the journey instances that satisfy the conditions selected by the controls in the summarization control area **3912**.

[0581] 4.6.2 Journey Model Visualization

[0582] In the illustrated embodiment of FIGS. 39A and 39B, a list steps control object 3906A is selected, which results in the summarization control area 3912 displaying steps identified in the journey instances that correspond to the journey visualizations 3908, 3910 displayed in the display area 3902. In addition, the summarization control area 3912 enables the user to select or deselect certain steps. Based on the selected steps, the data intake and query system can generate a journey visualization 3908 that corresponds to journey instances or one or more journey models that include the selected steps. In some cases, the data intake and query system 108 can exclude any journey instances that include a deselected step from being used to generate the journey visualization.

[0583] In the illustrated embodiment of FIG. 39A, all displayed steps (e.g., addtocart, changequantity, purchase, remove, view) are selected. As a result, the journey visualization 3908 corresponds to the journey instances or journey model(s) that include any one of the displayed steps. However, it will be understood that that the system 108 can generate the journey visualization 3908 in a variety of ways. For example, in some embodiments, the system 108 can generate the journey visualization 3908 using only the journey instances or journey model(s) that include each and every step identified in the summarization control area 3912, etc.

[0584] In the illustrated embodiment of FIG. 39B, some of the displayed steps (addtocart, purchase, remove) are deselected. As a result, the journey visualization 3910 corresponds to journey instances or journey model(s) that include any one of the selected steps. As mentioned, in some embodiments, the system 108 excludes any journey instances or model(s) that include a deselected step from being used to generate the journey visualization 3910, even if the journey instance or model includes one or more of the selected steps. However, it will be understood that that the system 108 can generate the journey visualization 3908 in a variety of ways. For example, in some embodiments, the system 108 can generate the journey visualization 3908 using the journey instances or model(s) that include any one of the steps selected from the summarization control area 3912, etc.

[0585] In addition to the steps of the journey instances, the journey visualizations 3908, 3910 can include start/end nodes. The start/end nodes may or may not correspond to one or more step instances of a journey instance or steps of a journey model. In certain embodiments, the system 108 can use the start/end nodes to indicate which steps or step instances are first or last in a journey model or journey instance, respectively. For example, arrows from the start node can indicate which step or step instances is the first step or step instance of a journey model or journey instances, respectively (e.g., node corresponding to a step or step instance pointed to from the start node). Similarly, arrows to the end node can indicate which step or step instance is the last step or step instance of a journey model or journey instances, respectively (e.g., nodes corresponding to a step or step instance from which an arrow that points to the end node originate).

[0586] In the illustrated embodiments of FIGS. 39A and 39B, the journey visualizations 3908, 3910 are shown as a semi-circle or ring with the step nodes of the journey visualization being spaced along the arc of the semi-circle.

In this way, the system 108 can make it easier to observe the various paths between the step nodes. In some cases, the system 108 can generate the visualization such that the step nodes are equally spaced along the arc of the semi-circle. In such embodiments, if additional step nodes are to be displayed, the system 108 can automatically arrange the step nodes along the arc. In some embodiments, the step node closest to the start node corresponds to the step that is most frequently identified as the first step or step instance of a journey model or journey instance, respectively. In certain embodiments, the step node closest to the start node corresponds to the step that is identified for being displayed in that location. Although, illustrated as a semi-circle or ring, it will be understood that the journey visualizations 3908, 3910 can be displayed in a variety of formats, such as a full circle, line, triangle, square, rectangle, or other shape, etc. In various implementations, the journey instances or model(s) may have their steps (or step instances) ordered by time, as previously discussed. In such implementations, the journey visualizations 3908, 3910, may roughly flow from an origin point to an ending point (e.g., top-to-bottom or bottom-to-top with top/bottom being earliest in time and bottom/top being latest in time, left-to-right or right-to-left with left/right being earliest in time and right/left being latest in time), however even within such an exemplary visualization, some steps may not follow that strict placement, e.g., to improve readability.

[0587] In some embodiments, individual steps that appear in more journey instances relative to other steps may appear along a first arc and steps that appear in fewer journey instances relative to other steps may appear along a second arc. In some embodiments the first or second arc can be closer to a “center” of the semi-circle, such that distance from the center in the visualization may roughly correspond to frequency of appearance of that step in the various journey instances. Those skilled in the art will appreciate that other, similar adaptations to the visualizations are also contemplated here. For example, more than three arcs can be used or different lines can be used. As another example, the system can use highlights, colorization, or patterns to indicate the frequency with which steps appear in step instances, etc.

[0588] With continued reference to the journey visualizations 3908, 3910, various relationships between the steps in the journey model or steps instances in the journey instances can be identified. For example, journey visualizations 3908, 3910 can include edges (e.g., lines, arrows, etc.) between different step nodes. The edges can indicate the traversal from one step to another step and/or identify which step preceded another step in a journey model (or step instances in a journey instance). In some embodiments, the system 108 can determine the traversal from one step or step instance to another step or step instance based on a timestamp associated with an event that corresponds to a step or step instance. For example, the system 108 can determine that a journey instance traversed from a purchase step instance to a view step instance based on a timestamp associated with an event that corresponds to the purchase step instance that immediately precedes (relative to any other steps in the journey instance) a timestamp associated with an event that corresponds to the view step instance. As shown in the illustrated embodiment of journey visualization 3908, in some instances a step node can be immediately

preceded by the same type of step node, or steps may be repeatedly traversed as part of a journey model or instance.

[0589] In addition, characteristics of the edges of a journey visualization can indicate the frequency of a particular traversal or progression. For example, if a majority of journey instances indicate a traversal or progression from the addtocart step to the purchase step, and a minority of journey instances indicate a traversal from the addtocart step to the remove step, the journey visualization can indicate this relationship by making an arrow from the addtocart step node to the purchase step node more pronounced than an arrow from the addtocart step node to the remove step node. In some cases, the more pronounced edge can be thicker, darker, or have a different pattern (e.g., solid vs. dashed) or color than a less pronounced edge. As such, more pronounced edges between steps nodes can indicate a greater frequency of a particular traversal than less pronounced edges between step nodes.

[0590] It will be understood that the edges can be configured to convey information as desired. For example, less pronounced edges can indicate that a particular traversal is more common, etc. Accordingly, the journey visualization **3908** can communicate significant amounts of information to a user about the underlying events, data sources, and computing systems, including, but not limited to, the step instances of journey instances, steps of a journey model, order of steps/step instances, frequency of traversals between steps/step instances, starting steps/step instances and ending steps/step instances, etc. In other implementations, not shown here, numeric representations of information regarding the underlying events, e.g., the frequency of traversals between steps/step instances, may be shown within or in proximity to the various steps/step instances. In still other implementations, those numeric representations may be hidden until some interaction with the step node in the visualization, e.g., selection of that step node or zooming in on that step node.

[0591] It will be understood that the journey visualization can be displayed in a variety of ways. In some cases, more common steps can be shown as part of a first ring and less common steps can be shown as part of a second ring, such as an outer or inner ring relative to the first ring. In this way, the system **108** can communicate to a user a relationship between the various steps of the journey model. For example, the system **108** can identify steps that are found within a threshold number or percentage of journey instances as part of a first ring and identify steps that are not found within a threshold number or percentage of journey instances as part of a second ring. In some cases, the threshold number can vary depending on the total number of journey instances. In certain embodiments, the threshold number can depend on a percentile. For example, steps found in at least 30% of the journey instances can form part of a first ring and steps found in less than 30% of the journey instances can form part of a second ring. Additional rings can be used as desired.

[0592] In certain embodiments, sub-journeys or nested journeys can be displayed as part of a second ring. For example, if the step changequantity initiates a number of sub-processes or steps (also referred to as dependent steps), then the dependent steps can be shown as a loop next to the changequantity step. In this way, the journey visualization **3908** can indicate to a user steps related to nested journeys, etc. In some cases, the journey visualization can hide or

group dependent steps together until a user interacts with the parent step (e.g., step that lead to or relates to the nested journey). With reference to the example above, based on an interaction of the user with the changequantity step node, the journey visualization can display step nodes corresponding to the dependent steps related to the changequantity step.

[0593] In some embodiments, the user interface **3900** can enable a user to move the steps of the journey visualization **3908** in order to more readily view relationships. For example, it may be difficult to see which steps precede other steps, but by moving a step, the connections thereto from different steps may become more visible.

[0594] 4.6.3 Clusters of Journey Instances

[0595] With reference to FIGS. **40A** and **40B**, a cluster control object **3906C** is selected, which results in the summarization control area **3912** displaying information regarding various clusters of journey instances, and enabling a user to select the clusters as a journey visualization.

[0596] The clusters can correspond to one or more journey instances that include a particular grouping of steps and/or a particular order of steps. For example, some journey instances may include traversal through multiple steps, whereas other journey instances may include traversal through only one step. The data intake and query system **108** can analyze the identified journey instances to determine how many or what percentage of journey instances are similar. The data intake and query system **108** can group or cluster the similar journey instances together and provide information about the clusters to a user.

[0597] In the illustrated embodiments of FIGS. **40A** and **40B**, the data intake and query system **108** has identified multiple clusters of journey instances. Information about five of the identified clusters is displayed in the summarization control area **3912**. The displayed information about the clusters **4004A-4004E** can include an identification of the different clusters, analytics about the different clusters, and/or an indication of the steps included in the different clusters, etc.

[0598] In the illustrated embodiments of FIG. **40A**, **40B**, the displayed information about a first cluster **4004A** indicates that the journey instances in that cluster make up 9% of the journey instances generated from the set of data, and further indicates that the first cluster includes a single step. Accordingly, the journey instances that form part of the first cluster include a step instance corresponding to the same step.

[0599] The displayed information about the third cluster **4004C** indicates that the journey instances in the third cluster make up 4% of the journey instances generated from the set of data. The displayed information **4004C** further indicates the steps identified in the journey instances of the third cluster, as well as an order of the steps. In some embodiments, the order of steps indicates the order of steps for all journey instances of the third cluster. In certain embodiments, the order of steps indicates a common or most common order of step instances for journey instances of the third cluster. Accordingly, in some embodiments, the journey instances that form part of the third cluster include step instances of the same steps, as well as the same order of steps. In certain embodiments, the journey instances that form part of the third cluster include the step instances of the same steps, but not necessarily the same order of steps.

[0600] In some embodiments, to indicate the steps and/or order of steps for journey instances of a particular cluster,

the summarization control area **3912** can include an indicator, such as a graphic, name, etc., for each step. In certain cases, each distinct step can be uniquely identified, such as by color, shading, pattern, word, etc. Thus, by looking at the summarization control area **3912**, a user can identify which steps are found in the journey instances of a particular cluster, and in some cases, the order of those steps. In the illustrated embodiment of FIG. **40A**, the summarization control area **3912** includes a distinct box for each step. Further, the box is patterned after the box used for the step nodes in the journey visualization **4002**.

[0601] Similarly, displayed information **4004B**, **4004D**, **4004E** is included for the second, fourth, and fifth clusters, indicating a percentage of the journey instances that make the respective cluster and identifying at least the steps found in each cluster. It will be understood that the displayed information **4004A-4004E** can include less or more information about the clusters. For example, the displayed information **4004A-4004E** can indicate a total number of journey instances in each cluster, display information about each and every cluster, etc.

[0602] As mentioned, the user interface **3900** enables the user to select a cluster in order to display a journey model associated with the cluster. In the illustrated embodiment of FIG. **40A**, the display information **4004A** corresponding to the first cluster has been selected. In response, the user interface displays a journey visualization **4002** that corresponds to the selected cluster. In some embodiments, the data intake and query system **108** generates a journey model based on the selection of a cluster. In certain cases, the data intake and query system **108** can generate the journey model by combining the journey instances that form the cluster. As illustrated, the journey visualization **4002** includes a single step node “view.” As such, a single arrow goes to the “view” step node from the start node and a single arrow goes to the end node from the “view” step node.

[0603] In the illustrated embodiment of FIG. **40B**, the display information **4004D** which corresponds to the fourth cluster is selected. In response, the system **108** aggregates the information about the clusters corresponding to display information **4004A-4004D** and displays a journey visualization based on the aggregate information. For example, the journey visualization **4006** can demonstrate the various paths found in 21% (sum of journey instances of the first four clusters) of the journey instances generated from the set of data.

[0604] With reference to the illustrated embodiment, 9% of the journey instances include a “view” step instance, 5% of the journey instances include an “addtocart” step instance, 4% of the journey instances include “addtocart,” “purchase,” “purchase” step instances (in that order), and 3% include “addtocart,” “purchase,” step instances (in that order). Based on the selection of the display information **4004D**, the system **108** generate and displays the journey visualization **4006** that shows the paths for the journey instances of the different clusters.

[0605] Further, as “addtocart” is the most frequent first step of the combined clusters (e.g., it makes up the first step in 12% of the journey instances or >50% of the selected journey instances), the system **108** includes an indication that “addtocart” is the most frequent first step using a solid line, whereas a dashed line to the “view” step node is used to indicate that the “view” step occurs less frequently as the first step. Similarly, the journey visualization **4006** uses

different weights or patterns to indicate the frequency of transitions between the steps corresponding to the step nodes (other indications of frequency can be used as desired). As mentioned herein, in some cases, the journey visualization **4006** can include multiple arcs or paths and include more frequent steps on a first arc or path and less frequent steps on a second arc or path.

[0606] In some embodiments, the system **108** can use the clusters or selected clusters to generate one or more journey models (ordered or unordered). For example, the journey visualization **4006** can correspond to an unordered journey model that includes the steps “view,” “addtocart,” and “purchase.” Thus, the journey visualization can illustrate the various paths that journey instances take through the steps of the unordered journey model.

[0607] In certain embodiments, the journey visualization **4006** can illustrate multiple ordered journey models. For example, the system can generate one journey model based on the first cluster of journey instances (ordered journey model with the sequence “view”), a second journey model based on the second cluster of journey instances (ordered journey model with the sequence “addtocart”), a third journey model based on the third cluster of journey instances (ordered journey model with the sequence of steps “addtocart,” “purchase,” “purchase”), and a fourth journey model based on the fourth cluster of journey instances (ordered journey model with the sequence of steps “addtocart,” “purchase”). Thus, the journey visualization **4006** can illustrate the various paths of four journey models.

[0608] 4.6.4 Filtering Journey Instances

[0609] In the illustrated embodiment of FIG. **41**, a filter control object **3906B** is selected, which results in the summarization control area **3912** displaying various filter controls **4104A**, **4104B**, **4104C** that enable a user to filter journey instances or models used to generate the journey visualization **4102**. Although only three filter controls are shown, it will be understood that fewer or more filter controls can be included as desired.

[0610] The filter controls **4104A-4104C** can be implemented as fields, drop-down menus, check boxes, etc., as desired. In the illustrated embodiment, the filter controls **4104A**, **4104C** are implemented as fields and the filter control **4104B** is implemented as a drop-down menu.

[0611] The filter controls **4104A**, **4104C** can be used to identify one or more steps used to filter the journey instances or models. For example, in the illustrated embodiment of FIG. **41**, the user has entered “view” and “purchase” to indicate that the journey instances or models are to be filtered based on some relationship between the view step and purchase step. In some embodiments, as a user types in the filter controls **4104A**, **4104C**, the data intake and query system can provide a list of the steps that can be selected. For example, as the user types “view,” the user interface **3900** can display “purchase,” “addtocart,” “view,” “changequantity,” and “remove,” to enable a user to identify the steps associated with the events/journey model.

[0612] The filter control **4104B** can be used to identify the type of relationship between the selected steps that is to be used to filter the journey instances. In the illustrated embodiment of FIG. **41**, the user has selected the relationship “eventually followed by,” to indicate that the journey instances that include a “view” step instance (or journey models with a “view” step) that is eventually followed by (e.g., intervening steps are ok) a “purchase” step instance (or

journey models with a “view” step) are to be used to generate the journey visualization **4102**. It will be understood that additional or different controls can be used to identify a relationship between the steps identified in filter controls **4104A**, **4104C**. For example, the identified relationship can include, but is not limited to, “immediately followed by” or “immediately preceded by” indicating that a particular step is to immediately follow or precede another step with no intervening steps, “ends with” or “start with” indicating that a journey instance is to end or begin with a particular step, respectively, or “passes through” indicating that a journey instance is to include a particular step and/or the particular step is not to be found at the beginning or end of the journey instance. In some embodiments, the data intake and query system can filter out journey instances that do not satisfy the requirements of the filter controls **4104A-4104C**. Additionally, multiple filters, or multi-step filters, although not pictured in the visualization of FIG. **41**, can be used. For example, the filters could include a particular sequence of three or more steps/step instances, transition between steps/step instances within a threshold amount of time, etc. As such, the journey model and corresponding visualization **4102** can be formed from a subset of the total journey instances generated by the data intake and query system **108** from the set of data.

[0613] 4.6.5 List Display of Journey Instances

[0614] Similar to FIG. **41**, in the illustrated embodiment of FIG. **42**, the filter control object **3906B** is selected, which results in the summarization control area **3912** displaying various controls **4104A**, **4104B**, **4104C** that enable a user to filter journey instances or journey models. As described in greater detail above with reference to FIG. **41**, the filter controls **4104A-4104C** can be used to filter journey instances for the display area **3902** and journey model.

[0615] However, differing from FIG. **41**, in the illustrated embodiment of FIG. **42**, the list summarization selection object **3904A** is selected, which results in the display area **3912** displaying a listing of information related to journey instances that can be used to generate one or more journey models.

[0616] In the illustrated embodiment, the listing includes a pivot ID column **4202**, start time column **4204**, end time column **4206**, total duration column **4208**, event count column **4210**, and a sequence column **4212**, as well as journey instance rows **4214A-4214H** (generically referred to as journey instance row **4214**) for each journey instance. It will be understood that the information displayed can include fewer, more, or different information, as desired. For example, the information displayed can include, but is not limited to, an identification of similar journey instances or clusters of journey instances, etc.

[0617] The pivot ID column **4202** can identify the field value of the pivot ID field used to identify the journey instances. With reference to FIGS. **37A** and **37B**, it will be noted that some of the field values displayed in the pivot ID column **4202** correspond to some of the field values displayed in the field value preview section **3706** of FIGS. **37A** and **37B**. Further, as shown, each row in the pivot ID column **4202** includes a unique value. As discussed previously, the field values can be used to identify related events. In some embodiments, such as when multiple data sources are used, the pivot ID column **4202** can include the combination of field values from the different data sources used to generate a particular journey instance. In certain embodiments, when

multiple data sources are used, multiple pivot ID columns **4202** can be included, with each column displaying a pivot ID associated with the particular journey instance.

[0618] The start time field **4204**, end time column **4206**, and total duration **4208**, can indicate the start time, end time, and total duration, respectively, of a particular journey instance. The event count column **4210** can indicate the total number of events or step instances in a journey instance or total number of unique events or step instances in a journey instance. As mentioned, in some cases, some steps may be repeated in a journey instance (e.g., multiple step instances corresponding to the same step). Thus, the total number of events or step instances in a journey instance may be different from the total number of unique events or steps in a journey instance.

[0619] The sequence column **4212** can indicate a particular sequence of a journey instance. For example, the sequence column **4212** can identify the first and last steps or step instances of a journey instance, as well as the sequence of steps between the first and last steps. In some embodiments, each step can be uniquely identified, such as by, using a different color or pattern. For example, with reference to the steps identified on FIG. **39A**, the “addtocart” step can be colored yellow, the “purchase” step can be colored maroon, the “view” step can be colored orange, the “changequantity” step can be colored gray. In such embodiments, the sequence column **4212** can use the unique identification of the steps to indicate the particular sequence between steps of a particular journey instance. For example, with reference to journey instance row **4214A**, the sequence column can include an orange block, yellow block, and maroon block indicating that the sequence for the three events/steps in that journey instance was “view,” “addtocart,” and “purchase.” Furthermore, in some embodiments, the sequence column **4212** can indicate whether certain steps are repeated within a particular journey instance, as illustrated in journey instance row **4214E**.

[0620] It will be understood that a variety of user interfaces can be used to display journey visualizations in a myriad of ways. For example, it will be understood that any one of the user interfaces described above with reference to FIGS. **18** and **31-26** can be used to display the journey instances, clusters of journey instances, nested journey instances, or journey models generated by the data intake and query system **108**.

4.7 Journey Instance and Model Flows

[0621] FIG. **43** is a flow diagram illustrating an embodiment of a routine **4300** implemented by one or more computing devices in a networked computer environment **100** for enabling identification of one or more pivot identifiers and/or one or more step identifiers. For example, the routine **4300** can be implemented by a client device **102**, host device **104**, and/or any one, or any combination, of the components of the data intake and query system **108**. However, for simplicity, reference below is made to the system **108** performing the various steps of the routine **4300**.

[0622] At block **4302**, the system executes a query. The query can include one more commands or filters to identify a set of data, which can include events. For example, the query can identify one or more time constraints or time ranges, one or more data sources, one or more fields or field values, etc. Based on the filters or commands in the query, the system can identify events that satisfy the filters or

commands. For example, if the query identifies one or more data sources, the system can identify a set of data from the one or more data source and/or exclude data or events from data sources not identified by the query. Similarly, the system can, using the query, identify a set of data that satisfies one or more time constraints or ranges, or identify events with a particular field or field value. In some embodiments, the system can receive the query via one or more user interfaces. In certain embodiments, the query is in search processing language, or can be generated based on a selection of one or more icons in a user interface. In some embodiments the query can be based on a data stream identified by user. The data stream can include events from one or more data sources, etc.

[0623] As described herein, the events of the set of data can include raw machine data associated with a timestamp. In some embodiments, the events can be derived from or based on machine data and be associated with heterogeneous data source having heterogeneous formats. In certain embodiments, the events can include performance information for metrics information.

[0624] At block 4304, the system obtains or extracts fields. The fields can be obtained or extracted based on the set of data or the events in the set of data identified from the query. In some embodiments, the obtained fields can correspond to fields in the events or to fields associated with the events. For example, in some cases, the events themselves may not include fields or field identifiers. As a non-limiting example, the events may only include data and/or a timestamp or only include raw machine data associated with a timestamp. Accordingly, in some embodiments, fields related to the events can be obtained or extracted from one or more files associated with the events, such as one or more configuration files.

[0625] As described herein, the configuration files can relate to one or more data sources and identify field definitions for events associated with those data sources. For example, data coming from a particular source may have a particular format (and data from different source may have different heterogeneous formats), and field definitions in the configuration files, can identify how to extract field values for different fields from the data of a particular data source. Accordingly, based on an identification of the data sources associated with the set of data, the system can identify one or more configuration files. The system can then parse the configuration files to identify field definitions and field identifiers for fields associated with the set of data. In some cases, the system can identify the data sources associated with the set of data based on input received from a user or based on an analysis of the events and/or inverted or keyword indexes associated with the set of data.

[0626] Although described above with reference to using configuration files to obtain fields associated with the set of data, it will be understood that the system can identify the fields in a variety of ways. For example, the system can use a lookup table that relates events of a set of data to fields associated with the events or set of data. In some cases, the events or set of data can include the fields and the system can obtain the fields from the events or the set of data itself, etc.

[0627] At block 4306, the system populates a graphical user interface. As described herein, the system can generate and cause the display of a graphical user interface for a user. Some non-limiting examples of graphical user interfaces that can be generated are described herein with reference to

FIGS. 37A and 37B. As described herein, the user interface can include various sections. For example, the user interface can include a data source section, a field identifier section, a preview field value section, etc.

[0628] In certain embodiments, the data source section of the user interface can include identifiers for data source(s) and/or stream(s) associated with the set of data or events. In some cases, the system interface can enable a user to add new data sources or data streams. Further, in certain cases, upon selection of a particular data source or stream, the user interface can update the field identifier section to identify fields associated with data from the selected data source, etc.

[0629] In some embodiments, a field identifier section of the user interface can include field identifiers that correspond to the fields associated with the set of data. As described herein, the field identifiers can be associated with the data sources related to the set of data. Further, the user interface can include one or more interface objects to enable the selection of the field identifiers by a user. For example, the user interface can include checkboxes, drop down menus, fillable fields, etc.

[0630] In some embodiments, the preview field value section of the user interface can identify field values associated with one or more of the field identifier in the field identifier section. In some cases, the user interface can include field values corresponding to a field identifier selected from the field identifier section. In certain embodiments, the preview field value section can also include a count for each field value displayed therein indicating the number of events that include the respective field value.

[0631] The system can identify the field values for the preview field value section in a variety of ways. In some embodiments, the system can identify the field values based on an analysis of the set of data. For example, the system can parse events in the set of data to identify field values found therein. In some embodiments, the system can analyze a subset of the set of data or a subset of the events and identify the field values found in the subset of data or events. As the system analyzes the set of data or events, it can update the preview field value section with additional field values or updated counts, etc.

[0632] In certain embodiments the system can identify the field values based on one or more inverted or keyword indexes associated with the set of data or events. As discussed in greater detail herein, the system can include one or more inverted or keyword indexes that identify field-value pairs for data and/or events processed or stored by the system. Specifically, the inverted or keyword indexes can identify particular fields for the data and/or events, as well as field values in the data and/or events that correspond to the fields. The inverted or keyword indexes can also identify which events have a particular field-value pair.

[0633] Accordingly, using the identification of the events from the set of data, the system can analyze one or more inverted or keyword indexes that includes information about the events from the set of data to identify field values for the preview field value section. Specifically, the system can identify the inverted or keyword indexes that include field-value pair entries that identify the events of the set of data. For each event identified as part of a field-value pair entry, the system can ascertain the field value for the event from the field-value pair of the field-value pair entry. The identified field values can then be added to the preview field value section of the user interface.

[0634] Furthermore, in some cases, the system can use the inverted or keyword indexes to execute the query. As such, during the execution of the query, the system can identify the inverted or keyword indexes used to execute the query and refer back to them to identify the field values for the preview field value section.

[0635] The user interface can include additional graphical indicators as desired. In some cases, the user interface can indicate the number of fields identified as a pivot identifier, step identifier, attribute, etc. Further, the user interface can provide graphical indicators that enable a user to enter a query or one or more commands for the query, etc.

[0636] At block 4308, the system enables identification of one or more pivot identifiers and one or more step identifiers. For example, via the user interface, the system can enable a user to identify one or more pivot identifiers and/or one or more step identifiers used to process the set of data or events.

[0637] As described herein, the pivot identifiers can be used to relate different events or generate or build sets of events. In some cases, one or more events are related based on a pivot identifier to form at least part of a journey instance. In some cases, the system enables identification of one or more pivot identifiers based one or more drop down menus, check boxes, fillable fields, etc. For example, the user interface can enable a user to identify a particular field identifier (and its corresponding field) from the field identifier section as a pivot identifier.

[0638] Further, in certain embodiments the system suggests certain fields as possible field identifiers. In some cases, the system suggests fields based on a name or identifier for that field, the frequency with which it appears in the set of data, or the field values of a field. For example, the system can identify the fields associated with the set of data and identified names or field identifiers that have been used in the past as a pivot identifier.

[0639] In certain cases, the system can determine that fields like "sessionID," "userID," or others that appear to indicate an identifier are frequently used as pivot identifiers. As such, the system can use fuzzy logic to suggest fields with a name or identifier that is the same as or similar to fields used for pivot identifiers in the past, fields identified in the system as ID fields, or fields identified in the system as useful fields for identifying related events.

[0640] In some cases, the system can identify the top 10, 50, or 100, etc. field identifiers frequently used as a pivot identifier. The system can then use fuzzy logic to compare the identified top field identifiers with the field identifiers associated with the set of data. Field identifiers associated with the set of data that are similar to or match the top field identifiers can be suggested for use as a pivot identifier. In some cases, the system can make suggestions based on the user. For example, the system can identify the top 10, 50, or 100, etc. field identifiers typically selected by a particular user and suggest a field identifier associated with the set of data based on the identified top field identifiers of the user as described above.

[0641] In some embodiments, the system can suggest a field identifier based on its frequency within the set of data. For example, the system can identify the fields that are found in the most, least, or threshold number events of the set of data and suggest those fields as pivot identifiers.

[0642] In certain embodiments, the system can suggest field identifiers based on the field values of the field. In some

cases, if the system determines that the number of unique field values for a particular field satisfies a threshold number, then the system can recommend the field as a pivot identifier. For example, if the system determines that from a set of 1,000 events there are one hundred unique field values, then the system may recommend the field as a pivot ID. However, if the system determines that there are 950 unique field values for the set of 1,000 events, the system may determine not to suggest the field as a pivot identifier. However, it will be understood that the threshold for the number of unique field values or whether to recommend fields based on the fields being greater than or less than the threshold can be adjusted as desired.

[0643] In some embodiments, the system can determine the threshold based on a percentage of the events in the set of data. For example, the system can determine that for every 5, 10, or 20 events there should be a unique field value (e.g., the number of unique field values divided by the total number of events should be 5%, 10%, or 20%). Fields that have a quantity of unique field values that are closer to the threshold or target can be given a higher ranking and be more likely to be suggested by the system as potential pivot identifiers than fields that have a quantity of unique field values that are farther away from the threshold or target.

[0644] Similarly, if the system determines that the number of events that have the same field value satisfies a threshold, then the system can recommend the field as a pivot identifier. For example, if one field value is found in 50% of the events, then the system may rate the field lower than for a set of events that has a field value in <1%, 2%, or 5% of the events. Accordingly, the system can use information about the set of data itself and/or the user to suggest pivot identifiers.

[0645] In certain embodiments, the system can rank fields based on one or more criteria to determine which fields to suggest as pivot identifiers. As described above, the criteria can be based on any one or any combination of field name or identifier, field frequency in the set of data, number of unique field values, etc.

[0646] In certain embodiments, the step identifiers can be used to categorize the different events or group sets of events into subsets of events. For example, the system can use the step identifiers to group events into a particular step or step instance. In some cases, events similarly categorized based on a step identifier can correspond to the same step of a journey model, but may relate to different journey instances, e.g., because one or more field values identified as pivot IDs are not the same, or because other fields, field values, or other data is not the same. In some cases, the system enables identification of one or more step identifiers based one or more drop down menus, check boxes, fillable fields, etc. For example, the user interface can enable a user to identify a particular field identifier (and its corresponding field) from the field identifier section as a step identifier.

[0647] In some embodiments, the system can use all of the unique field values of the field that corresponds to the step identifier (or step ID field) as different steps. In certain embodiments, the system can enable a user to deselect one or more field values as steps. In such embodiments, events that include a deselected field value may not be included as part of journey models or instances even though they include a field value for the step ID field. In this way a user can identify the field values that are relevant for grouping and categorizing the events.

[0648] Similar to the pivot identifiers, the system can suggest one or more step identifiers. As discussed above, the system can suggest fields as step identifiers based on field identifiers, number of unique field values, and/or number of events that have a particular field value. However, in some embodiments, the thresholds for suggesting fields as step identifiers may be different than for suggesting fields as pivot identifiers. In some cases, the threshold for number of unique field values may be higher than the threshold for the number of unique field values for a pivot ID field (or vice versa). Similarly, in certain cases, the threshold for the number of number of events with the same field value for a step ID may be lower than the threshold for the number of events with the same field value for a pivot ID (or vice versa). For example, it may be desirable to have fewer unique steps compared to the number of unique journey instances (or vice versa).

[0649] Further, in some embodiments, the system can compare the number of unique field values for the step ID field with the number of unique field values for the pivot ID field and make suggestions accordingly. For example, if the number of unique field values for the step ID field is greater than the number of unique values for the pivot ID field (or vice versa), the system can suggest that either the pivot ID or step ID be changed. It will be understood that the system can use a variety of techniques to suggest fields as pivot IDs, step IDs, and the like.

[0650] The system can use fewer, more, or different blocks as part of routine 4300, or perform the blocks of routine 4300 in a different order or concurrently. For example, in some embodiments, the system may not generate a graphical user interface. In such embodiments, a user can communicate selections of step identifier(s) or pivot identifier(s) via email, command line, etc. Further, any of the steps described herein with reference to routine 4300 can be combined with one or more steps described herein with reference to routines 4400 and 4500.

[0651] In certain embodiments, the user interface can enable a user to select fields for attributes, enter a query, enter filters for the query, etc. In some embodiments, based on a selection of a field as an attribute, the system can track the field values for the identified field in each event and display commands for the user to filter, sort, or process journey instances based on the attribute field.

[0652] In some embodiments, the system can use the identified pivot identifier(s) and step identifier(s) to generate or build sets or subsets of events, journey instances, clusters of journey instances, and/or journey models. For example, the system can use the pivot identifiers to identify events that are part of a particular journey instance and use the step identifier(s) to group the events into subsets of events or as step instances of the journey instance. As another example, the system can use the step identifiers to identify steps of an unordered journey model, and use the pivot identifiers to identify an ordered journey model.

[0653] Furthermore, in certain embodiments, the system can generate visualizations based on the identified pivot identifier(s) and step identifier(s). For example, the system can build sets of events, subsets of events, journey models, and/or journey instances, and display visualizations of them, as described in greater detail herein. Further, the visualizations can include indications of an ordering of, transitions between, or progression through, step instances of one or more journey instances or steps of a journey model.

[0654] FIG. 44 is a flow diagram illustrating an embodiment of a routine 4400 implemented by one or more computing devices in a networked computer environment 100 for generating a journey instance or model. For example, the routine 4400 can be implemented by a client device 102, host device 104, and/or any one, or a combination, of the components of the data intake and query system 108. However, for simplicity, reference below is made to the system 108 performing the various steps of the routine 4400.

[0655] At block 4402, the system identifies a set of data, which can include events. As described herein the system can identify the set of data based on the execution of a query as described in greater detail above at least with reference to block 4302 of FIG. 43.

[0656] At block 4404, the system receives one or more pivot identifiers. As described herein, in some embodiments, the system can receive one or more pivot identifiers via a user interface. However, it will be understood that the system can receive the pivot identifier in a variety of ways. The pivot identifier(s) can be used to relate, identify, or otherwise associate sets of events. As described herein, in some cases, the pivot identifier can correspond to a field associated with the set of data or events of the set of data. The system can use the field, or pivot ID field, to identify the sets of events. For example, the system can relate events with the same field value for the pivot ID field as a set of events.

[0657] In some embodiments, the system can identify a set of events based on multiple pivot identifiers. In some cases, the set of events identified based on multiple pivot identifiers can correspond to events from multiple data sources. For example, the system can identify a first group of events from a first data source that have a first field value for a first pivot ID field and the second group of events from second data source that have a second field value for the second pivot ID field. Based on one or more gluing events that include the first field value and the second field value, the system can identify a relationship between the first field value and the second field value. Based on the identified relationship between the first field value and the second field value, the system can relate the first group of events and the second group of events as a set of events. In some embodiments, multiple gluing events in a particular data source can be used to relate events that do not have a gluing event in common or are not otherwise relatable. For example, a first gluing event can be used to relate events in Group A and Group B and a second gluing event can be used to relate events in Group B and Group C. As such, events in Group A and Group C can be related without a gluing event that links them directly. The different groups of events may correspond to events from the same, similar, or heterogeneous data sources.

[0658] In some cases, the one or more gluing events can be found in the first group of events or the second group of events. Further, in some instances, a gluing event may have the first field value in a location corresponding to the first field, and may have the second field value in a location that does not correspond to the second field (or may not have the second field). Accordingly, in some instances, the system can perform a search on the event or consult a keyword entry of an inverted or keyword index to identify the second field value in the gluing event.

[0659] In certain cases, multiple pivot identifiers can be used to identify a set of events and a nested set of events that are interrelated. For example, the system can identify a first group of events that have a first field value for a first pivot ID field and a second group of events that have a second field value for a second pivot ID field. In some cases, events in the first group may also have the second field value for the second pivot ID field and/or events in the second group may also have the first field value for the first pivot ID field. Further, the events in the first group and the events in the second group may be associated with the same data source.

[0660] In some cases, the events of the second group may occur as a result of the occurrence of an event in the first group. For example the occurrence of a particular event may spawn one or more sub processes that results in one or more events (also referred to as dependent events), which can be identified using a separate pivot ID. The dependent events may or may not include the same field value for the first pivot ID field, and may also share the same field value for a different pivot ID field.

[0661] Based on one or more gluing events that include the first field value and the second field value, the system can identify relationship between the first field value and second field value. Based on the identified relationship, the system can relate the first group of events with the second group of events as a set of events. Further, based on an identification of a relationship between the dependent events and the parent event, the system can determine that the second group of events corresponds to a nested set of events or a nested journey instance.

[0662] At block 4406, the system receives one or more step identifiers. As described herein, in some embodiments, the system can receive one or more step identifiers via a user interface. However, it will be understood that the system can receive the step identifier in a variety of ways.

[0663] The step identifier(s) can be used to categorize events as one or more steps or step instances and/or group the sets of events as one or more subsets of events. As described herein, in some cases, the step identifier can correspond to a field associated with the set of data or events. The system can use the field to categorize the events and/or group events in a set of events into one or more subsets of events. In some cases, the system can use the step identifier to identify a journey model or to identify steps of a journey model. In certain embodiments, the identified steps can form an unordered journey model. Further, in some cases, based on user input or based on one or more journey instances, the system can build an ordered journey model from the unordered journey model.

[0664] As described herein, in some cases, the field values of the step ID field can be used to identify events as steps or step instances. In some embodiments, each unique field value of a step ID field can be identified as a separate step. In certain embodiments, a subset of the field values of the step ID field can be identified as separate steps. For example, a step ID field may have twenty unique field values, but the system may use fewer than the twenty unique field values to identify different steps or step instances. As described herein, in some cases, the system can exclude certain field values of the step ID field for use as steps based on input received from a user or based on an analysis of the field values of the step ID field.

[0665] As described herein, in certain embodiments, the system can use multiple step identifiers to categorize events

and/or group events in a set of events into subsets of events. For example, as described above with reference to pivot identifiers, multiple step identifiers can be used to group sets of events that come from multiple data sources into subsets of events. For example, in some cases, the system can receive a step identifier for each data source. In this way, the system can identify a field in events from each data source to categorize the events from the data source. In certain embodiments, one step identifier can be used for multiple data sources. For example, fields from different data sources used to categorize the events into steps can have the same or a similar field identifier. In such embodiments, the step identifier can identify the common field between the different data sources as the step ID field.

[0666] Further, similar to the pivot identifiers, the system can receive multiple step identifiers for a particular data source. In such embodiments, the system can use the step identifiers to identify events that are part of a nested set of events or nested journey instance. For example, events that are part of a nested set of events can include a different field that can be used to categorize them apart from the field used to categorize other steps that are part of the set of events. Accordingly, using a first step ID field to categorize events in the set of events and a second step ID field to categorize events in the nested set of events, the system can identify the events in a journey instance, as well as the events in a nested journey instance.

[0667] In some cases, the system can group multiple events together as part of the same step. Thus, a subset of the events of a journey instance can include one or more events. For example, if the system determines that multiple events are related to a “purchase” action, the system can group the events together as part of a “purchase” step. In some cases, the system can determine that multiple events are part of the same step based on the one or more pivot ID fields, step ID fields, or timestamps. For example, the multiple events related to the “purchase” step may all have the “purchase” as the field value for the step ID field, may all have a field value for the pivot ID field that matches the other events in the journey instance, and/or may all have iterative timestamps (e.g., no other events of the set of events fall between the events related to the “purchase” action). However, the events grouped together as part of the “purchase” step may have a field value for a second pivot ID field that matches each other. In this way, the system can identify the events as part of the journey instance and also group them together as part of a subset of steps or a single step.

[0668] Further, in some cases, the system can determine that a particular step has not occurred until a certain events are observed. With reference to the example above, the system can determine that a “purchase” action is not complete until it receives three events with particular step IDs. Accordingly, the system can group the three events as a subset of events or a step instance.

[0669] At block 4408, the system identifies or builds a journey. The journey can correspond to one or more journey instances and/or one or more journey models. As described herein, the system can identify journey instances and journey models in a variety of ways.

[0670] In some cases, to identify a journey instance, the system identifies a set of events based on the one or more pivot identifiers, groups the set of events into one or more subsets of events based on the one or more step identifiers, and orders the subset of events. In certain cases, the system

identifies step instances or subsets of events from a set of data based on the one or more step identifiers, and then relates the step instances or subset of events based on the one or more pivot identifiers. Accordingly, in certain embodiments, the pivot identifier(s) are used to identify related events or set of events and the step identifier(s) are used to categorize the related events into step instances or subsets of events.

[0671] In addition, as described herein the subset of events or step instances can be ordered based on a timestamp or other information associated with the events. The system can order the events before, after, or concurrently with identifying the related events or sets of data and identifying the step instances or subsets of events.

[0672] In some cases, the set of events can be based on the step identifier. For example, if an event includes a field value for a pivot ID field, but does not include a step ID field, field value for a step ID field, or includes an excluded field value for the step ID field, the system can exclude the event from the set of events.

[0673] As described herein, in some embodiments, events in a journey instance include a common field value or have the same field value for a field associated with or identified by a pivot identifier. Furthermore, when multiple journey instances are generated, each journey instance can correspond to a unique field value for the pivot ID field.

[0674] In certain embodiments, such as when multiple pivot identifiers are used, events in a journey instance can include at least one field value from a group of related field values. Each of the field values in the group of related field values can be associated with a different pivot identifier. In some cases, the system can use one or more gluing events to identify and form the group of related field values.

[0675] As described herein, in some instances, multiple events may correspond to a subset of events or a single step instance. For example, multiple events may be generated for a single action, such as a purchase. The system can identify the events generated for the single action and group them together as a subset of events or a step instance. In some embodiments, these related events may correspond to a nested journey instance.

[0676] As mentioned above, the system can categorize an event as any one of a plurality of steps or a step instance. In some cases, the system can determine the number of steps for a set of data based on a field associated with a step identifier. In some cases, each unique field value for the field associated with the step identifier can be identified as a step. In certain cases, as described herein, a subset of the unique field values of the step ID field can be identified as a step. Based on the field value for the step ID field in the event, the system can identify an event or subset of events as a particular step instance.

[0677] As discussed, as part of generating a journey instance, the system can identify an ordering of the subset of events or step instances. In some cases, the ordering can be based on a timestamp associated with each event or step instance. For example, the step instance with the earliest-in-time timestamp can be identified as the first step instance in the journey instance and the step instance with the latest-in-time time stamp can be identified as the last step instance in the journey instance, and so on. The ordered related events, ordered subset of events, or ordered steps instances can correspond to a journey instance.

[0678] Similarly, the system can identify a progression through the set of events, subset of events, or step instances based on the time stamp. For example, if a timestamp of Event1 is :33 and the timestamp of a Event2 is :56, and there are no events in the set of events with a timestamp between :33 and :56, the system can determine that the journey instance progressed from Event1 to Event2. However, if the timestamp of Event10 is :45 (and no other events between :33 and :56), then the system can determine that the journey instance progressed from Event1 to Event10 to Event2.

[0679] In addition to journey instances, the system can also generate one or more journey models. The journey models can include ordered journey models or unordered journey models. An ordered journey model can correspond to a certain number of steps in a particular order, and an unordered journey model can correspond to a certain number of steps without any particular order. Accordingly, in some embodiments a journey instance can be a representation or an example of an ordered or unordered journey model.

[0680] In some embodiments, the journey models can be built or generated based one or more journey instances or one or more ordered subsets of events. For example, one or more journey instances that include the same steps and the same order of steps can be combined to form an ordered journey model. Similarly journey instances that include the same steps but in different orders can be combined to form an unordered journey model. Furthermore, in some cases multiple journey instances with different steps and different orders of steps can be combined to form a journey model. For example, the system can identify steps for a journey model based on the different step instances used to form the journey model. The system can also identify journey instances that follow different paths through the steps of the journey model. The journey model generated from the journey instances can show all of the different paths through the identified steps of the journey model. In such embodiments, the various journey instances may have different steps and different orders of those steps, however, each journey instance can traverse through at least one step of the journey model.

[0681] In certain embodiments, a journey model can be built based on field values of one or more step ID fields. For example, the system can identify one or more field values of a step ID field as steps of an unordered journey model. In some cases, the system can generate an ordered journey model from the unordered model based on one or more timestamps, one or more pivot identifiers, and/or one or more journey instances or sets of events.

[0682] The system can use fewer, more, or different blocks as part of routine 4400, or perform the blocks of routine 4400 in a different order or concurrently. For example, the routine 4400 can include a block between blocks 4404 and 4406 for generating or building a set of events and/or include a block between blocks 4406 and 4408 for grouping the set of events into one or more subset of events. Further, any of the steps described herein with reference to routine 4400 can be combined with one or more steps described herein with reference to routines 4300 and 4500.

[0683] In some embodiments, as part of routine 4400, the system can identify clusters of journey instances. Each cluster of journey instances can correspond to journey instances that follow the same path through the same steps.

In some embodiments, a cluster of journey instances can correspond to an ordered journey model.

[0684] In certain embodiments, the system can generate one or more journeys without the one or more step identifiers. For example, based on the one or more pivot identifiers the system can identify related events, which can correspond to a journey instance. Further, in such embodiments, the system can order the events in the journey instance based on a timestamp associated with each event of the journey instance.

[0685] In some embodiments, the system can generate one or more journeys without the one or more pivot identifiers. For example, based on the one or more step identifiers the system can categorize the events of the set of data, which can correspond to a journey model. Accordingly, based on the one or more pivot identifiers, the system can identify the steps of a journey model.

[0686] In certain embodiments, as part of routine **4400**, the system can generate and display visualizations of the journeys. As mentioned, the journeys can correspond to journey instances or journey models. Accordingly, the system can generate and display visualizations of one or more journey instances and/or one or more journey models. Furthermore, the visualizations can identify progressions through the set of events, subset of events, journey instances, or journey models.

[0687] FIG. **45** is a flow diagram illustrating an embodiment of a routine **4500** implemented by one or more computing devices in a networked computer environment **100** for analyzing journey instances. For example, the routine **4500** can be implemented by a client device **102**, host device **104**, and/or any one, or any combination, of the components of the data intake and query system **108**. However, for simplicity, reference below is made to the system **108** performing the various steps of the routine **4500**.

[0688] At block **4502**, the system accesses journey instances. As described herein, in some embodiments, each journey instance can include one or more step instances, and each step instance can correspond to one or more events of a set of data. The step instances of the journey instances or subsets of events can be ordered. Further, the journey instances can be generated based on one or more pivot identifiers, one or more step identifiers, and/or one or more timestamps. The journey instances can be stored in memory or on disk. In some embodiments, to access the journey instances, the system can access a file that identifies particular events of a journey instance and an order of those particular events. In certain embodiments, this information can be stored in a relational database. In some embodiments, the file can include an identifier for each of the particular events. In this way, the system can reduce the memory required to store the journey instances.

[0689] Further, in certain embodiments, the events of a particular journey instance can correspond to events from one or more data sources. The data sources can be heterogeneous data sources that have heterogeneous data formats. In some embodiments, a journey instance can include a nested journey instance. For example, as described herein, the occurrence of one event can spawn one or more sub processes that generate one or more events. The dependent events can be related to each other as part of a nested journey instance and can be related to a larger or primary journey instance.

[0690] At block **4504**, the system analyzes the plurality of journey instances to generate a summary. In some embodiments, the summary can correspond to a single journey instance or multiple journey instances. In certain embodiments, the summary can correspond to one or more journey models or one or more clusters of journey instances.

[0691] The summary can include various analytics about the journey instances or journey models. For example, as described herein, the summary can indicate the number of journey instances built from a set of data, the number of events in the set of data, the identity of steps in a journey model, a sequence of the step instances in the journey instances, a sequence of steps in a cluster of journey instances or ordered journey model, a percentage of journey instances that represent or are an example of different ordered or unordered journey models, an indication of the frequency of steps across the different journey instances, an indication of the placement of the different steps across the different journey instances (e.g., first, last, etc.), time limits of the set of data, a distribution of the lengths of the journey instances or number of events in the different journey instances, average time of the journey instances, average time on each step of the journey instances, etc.

[0692] At block **4506**, the system generates a visualization. In some embodiments, the visualization can correspond to one or more journey instances or one or more journey models. In some embodiments, the visualization can correspond to multiple journey instances, or a cluster of journey instances, that include the same path through the same steps or an ordered journey model. In such cases, the journey instances can include step instances that correspond to the same steps of a journey model and that have the same order as an ordered journey model.

[0693] In certain embodiments, the visualization can correspond to multiple journey instances that have different paths through the same or different steps. For example, the visualization can include all journey instances for a set of data or all different paths between steps of a journey model based on the set of data. In some cases, one group of the journey instances may include one set of steps from the journey model and another group may include different steps, non-overlapping from the journey model.

[0694] In some embodiments, the visualization can include a numerical or non-numerical indication of the number or percentage of journey instances that include a particular order of step instances or include a particular passage between two or more step instances, or a particular passage to or from a particular step or step instance. In some cases, the visualization can include lines or arrows between different steps that are traversed by a journey instance. In some cases the errors or lines can be sized differently depending on the frequency or the number of journey instances that include a particular passage between two steps. For example, the visualization can include a larger or thicker arrow or line indicating a larger percentage or number of journey instances including a particular traversal compared to a smaller or thinner line or arrow. In some cases, the visualization can use different colors to indicate the frequency or number of journey instances that include a particular traversal. In this way, the visualization can facilitate the understanding of the topology of the system and/or the interactions between different data sources.

[0695] In some embodiments, the system can include information about each journey instance. For example, the

visualization can identify field values for the different journey instances, or the field used as the pivot identifier. In certain cases, the visualization can identify a duration for each journey instance, a number of events in a particular journey instance, and/or a sequence of events for a particular journey instance.

[0696] In certain embodiments, the visualization can include a summary of the journey instances identified from a set of data, the number of events identified from the set of data, the number of unique steps in the set of data, timing requirements used to generate the journey instances or process the set of data. In some embodiments the visualization can include one or more graphics indicating a distribution of the number of events in the journey instances.

[0697] In certain embodiments, a user interface can include various controls to modify the visualization. For example, the controls can enable a user to filter journey instances based on a particular step, a particular order or sequence of steps, particular transition between steps, a particular first step, a particular last step, etc. Furthermore, in some embodiments, the user interface can include various controls to view visualizations of clusters of journey instances, journey models, or journey instances with the same steps and same sequence of steps, etc. In some cases, the user interface can include controls to modify the visualization to identify one or more journey models derived from or built based on different journey instances.

[0698] In some embodiments, the visualization can include multiple nodes along an arc, such as a circle, semi-circle, or half-moon. Some or all of the nodes can correspond to a step or step instance. In some embodiments, the nodes are ordered based on timestamps associated with the corresponding step instance. For example, nodes corresponding to steps that are earliest in time for a journey instance or model can be closer to an origin point (e.g., top, bottom, side, etc.) and nodes later in time can be progressively closer to an end point and can be located along an arc length between the origin point and end point. In certain embodiments, the steps are ordered based on frequency of transitions. For example, the first node can correspond to the node that is most frequently the first node in a journey, the second node can correspond to the step that is most frequently traversed to from the first node, and so forth. In addition, the visualization can include indications that identify transitions between the different nodes of the arc. In some implementations, the visualization may be manipulated by the user, to allow the user to move, position, zoom, and/or focus on elements of the visualization, e.g., nodes and paths. In some implementations, the visualization may include numeric representations of data underlying the visualization, e.g., corresponding to journey models, journey instances, or data underlying the respective journey instances, individually or in aggregate.

[0699] In some cases, the visualization can include multiple arcs. The first arc can correspond to steps that occur at least a threshold number of times. The second arc can correspond to steps that occur less than a threshold number of times.

[0700] Further, in some embodiments, the first arc can correspond to steps of a journey instance, and the second arc can correspond to steps of a nested journey instance. In some cases, the nodes of the second arc can be positioned proximate the node that corresponds to the step of the journey instance that is related to the nested journey instance. For

example, if the nodes for the nested journey correspond to dependent events, then they can be positioned proximate the node that caused them to occur.

[0701] The system can use fewer, more, or different blocks as part of routine 4500, or perform the blocks of routine 4500 in a different order or concurrently. Further, any of the steps described herein with reference to routine 4500 can be combined with one or more steps described herein with reference to routines 4300 and 4400. For example, in some embodiments, the routine 4500 can include receiving one or more pivot identifiers and/or one or more step identifiers, generating the journey instances and models, etc.

4.8 Additional Journey Visualizations

[0702] FIG. 46 is a diagram illustrating an embodiment of a journey visualization 4600 that can be displayed in the display area 3902 or otherwise included in the user interface 3900 or displayed. As described herein, the system 108 can generate a variety of journey visualizations to indicate relationships between events and topologies. Accordingly, the journey visualization 4600 represents an embodiment of the journey visualizations that can be generated by the system 108.

[0703] In the illustrated embodiment, the journey visualization 4600 indicates a relationship between data sources and the events/steps/step instances of one or more journey instances or one or more journey models. For example, the system 108 can group the events/steps/step instances based on their data source and display a traversal through the steps across the different data sources. In the illustrated embodiment, the journey visualization 4600 includes data source indicators 4602, 4604, 4606 indicative of the data sources or streams associated with one or more journey instances or journey models, nodes A, B, C, D, E indicative of the events, steps, or step instances associated with the one or more journey instances or journey models, as well as a progression between the events, steps, or step instances of the one or more journey instances or journey models.

[0704] As a non-limiting example, suppose journey visualization 4600 represents a particular journey instance, the nodes A, B, C, D, E represent the steps instance of the journey instance, and the data source indicators 4602, 4604, 4606 indicate the data sources related to the journey instance. With reference to the example, the journey visualization 4600 indicates that the journey instance includes five step instances A, B, C, D, E across three data sources 4602, 4604, 4606. Further, the journey visualization 4600 indicates the progression through the step instances based on their placement, with step instances that occurred earlier in time being located higher in the journey visualization than step instances that occurred later in time. In the illustrated embodiment, the journey instance began with the step instance A, and progressed through step instances B, C, and D, and ended with step instance E. It will be understood that the step instances can be placed in any configuration to indicate an order (e.g., bottom-top, left-right, right-left, font size, color, pattern, etc.)

[0705] In addition, the journey visualization 4600 identifies the data sources related to each event. Specifically, the journey visualization indicates that step instance A is related to or came from data source 4602, steps B and D are related to data source 4604 and step instances C and E are related to data source 4606.

[0706] The journey visualization 4600 also includes indications of the traversal of the journey instance between the different data sources. In addition, in the illustrated embodiment, the journey visualization provides one indicator for traversals in one direction of the data sources (e.g., data source 4602→data source 4604 and data source 4604→data source 4606) and a different indicator for traversal in the opposite direction (e.g., data source 4606-4604, etc.).

[0707] Although the example identified was with reference to step instances and a journey instance, it will be understood that the journey visualization 4600 can also be used to illustrate the relationship between events of a journey instance or steps or events of one or more journey models, etc. In some embodiments, they journey visualization can indicate the traversals between the events or steps for multiple journey models or journey instances. For example, similar to the journey visualizations 3908, 3910, 4006, and 4102, the journey visualization 4600 can include multiple lines (same or different pattern) between the various nodes A, B, C, D, E. Further different patterns or weights of the lines can indicate different relationships (e.g., frequency or number of transitions, etc.) between the underlying steps, step instance, or events, as described herein.

[0708] FIG. 47 is a diagram illustrating an embodiment of a journey visualization 4700 that can be displayed in the display area 3902 and step selection controls 4702 that can be displayed in the summarization control area 3912 of the user interface 3900, or otherwise included in a user interface or displayed. As described herein, the system 108 can generate a variety of journey visualizations to indicate relationships between events and topologies. Accordingly, the journey visualization 4700 represents an embodiment of the journey visualizations that can be generated by the system 108 to indicate a relationship between an event/step/step instance with other events/steps/step instance of one or more journey instances or models.

[0709] For simplicity, reference will be made to an indication of a relationship of an anchor step with other steps of a one or more ordered journey models, however, it will be understood that, depending on the embodiment, step instances or events can be used instead of steps and that journey instance(s) can be used in place of the journey models. With the above in mind, in the illustrated embodiment, the journey visualization 4700 includes various nodes indicative of steps associated with different ordered journey models. Further, the illustrated embodiment includes step selection control 4702 to select various steps of an unordered journey model.

[0710] In the illustrated embodiment a step (step 5) corresponding to node 5 has been selected as an anchor step. Based on the selection, the system 108 generates the journey visualization 4700 to indicate the relationship between step 5 and the other steps of various ordered journey models. To illustrate the relationship between step 5 and the other steps, the journey visualization 4700 includes columns 4704A, 4704B, 4704C, 4704D, 4704E, with each column indicating a distance from the anchor step. In the illustrated embodiment, node 5, corresponding to step 5, is placed in column 4704D. Thus, nodes in column 4704E indicate steps that occur one step after step 5 in one or more journey models or after step 5 with no intervening steps in that particular journey model. Nodes in column 4704C indicate steps that occur one step before step 5 in one or more journey models or before step 5 with no intervening steps in that particular

journey model. Thus, nodes in column 4704B and 4704A indicate steps that occur two and three steps, respectively before step 5 in one or more journey models or before step 5 with one or two intervening steps, respectively, in that particular journey model.

[0711] By selecting steps 3 and 8, which correspond to nodes 3 and 8, in addition to step 5, the system 108 can filter out journey models that do not include any of steps 3, 5, or 8, journey models that do not include steps 3 and 5 or steps 3 and 8, or journey models that do not include steps 3, 5, and 8. Accordingly, the journey visualization 4700 can show paths of journey models that include different combinations of step 5 with other steps, such as steps 3, and 8.

[0712] In the illustrated embodiment, the journey visualization 4700 shows the paths of journey models that have steps 3 and 5 or that have steps 5 and 8. Solid lines indicate paths between steps of ordered journey models that include steps 8 and 5 (step 8 occurring three steps before step 5) and steps between ordered journey models that step 3 and step 5 (step 3 occurring one step before step 5 for one or more journey models). Thus, as seen in the journey visualization 4700 at least two ordered journey models includes steps 3 and 5 and a step that precedes step 3 (e.g., the nodes in column 4704B that connect to node 3 indicate steps in different ordered journey models that also include steps 3 and 5). Similarly, journey models with steps 5 and 3 or steps 5 and 8 only include two different paths after step 5 (e.g., the nodes in column 4704E indicate two steps that come after step five in any of the journey models).

[0713] The journey visualization 4700 can further indicate additional paths of journey models through step 5, but that do not include steps 3 or 8. In the illustrated embodiment, the journey visualization indicates these additional paths through step 5 using dashed lines and dashed circles. For example, at least three journey models include step 5, but does not include step 3 or 8 (e.g., the dashed node in column 4704C with a dashed line to node 5 and the blank dashed nodes in column 4704A with dashed lines to the solid node in column 4704B). In some embodiments, the dashed circle for node 8 can indicate that step 8 does not occur in the same ordered journey models as step 3.

[0714] It will be understood that a variety of visualizations can be used to indicate the relationship between the steps of the journey models. Further, as indicated above, the visualization 4700 is not limited to steps and journey models, but can indicate relationship between events of journey instances or journey models or relationships between step instances of journey instances.

[0715] FIG. 48 is a diagram illustrating an embodiment of a journey visualization 4800 that can be displayed in the display area 3902 and event selection controls 4802 that can be displayed in the summarization control area 3912 of the user interface 3900, or otherwise included in a user interface or displayed. As described herein, the system 108 can generate a variety of journey visualizations to indicate relationships between events and topologies. Accordingly, the journey visualization 4800 represents an embodiment of the journey visualizations that can be generated by the system 108 to indicate a relationship between a parent event/step/step instances and dependent events/steps/step instances.

[0716] For simplicity, reference will be made to an indication of a relationship of a parent event with dependent events of a journey instance, however, it will be understood

that, depending on the embodiment, step instances or steps can be used instead of events and that journey model(s) can be used in place of the journey instance. With the above in mind, in the illustrated embodiment, the journey visualization 4800 includes various nodes indicative of events associated with a journey instance. Further, the illustrated embodiment includes event selection control 4802 to select various events of an unordered journey model.

[0717] In the illustrated embodiment, an event (event 5) corresponding to node 5 has been selected from a various events of a journey instance. Based on the selection, the system 108 generates the journey visualization 4800 to indicate the relationship between parent event 5 and dependent events (from the same or different data sources as each other and the parent event) of the journey instance, or nested journey instances. To illustrate the relationship between the parent event 5 and the dependent events, the journey visualization 4800 includes rows 4804A, 4804B, 4804C, 4804D, 4804E, with each row indicating a distance from or relationship to the parent event, or indicating a distinct nested journey instance related to event 5.

[0718] In addition, the journey visualization indicates a timing relationship between the various events, with nodes corresponding to events occurring earlier in time located farther to the left of nodes corresponding to events occurring later in time (e.g., event related to node C occurs approximately 60 second before the event corresponding to node F).

[0719] In the illustrated embodiment, parent node 5, corresponding to parent event 5, is placed in column 4804A. Connecting lines from node 5 to nodes A and B can indicate that events corresponding to events A and are generated based on the occurrence of event 5, or are dependent events. Similarly, the lines between nodes C and D and between nodes E and F can indicate that the events corresponding to nodes D and F are dependent events (or occurred based on the occurrence of) of the events corresponding to nodes C and E, respectively. In some embodiments, all of the events corresponding to the nodes in the different rows 4804B, 4804C, 4804D, 4804E can be identified as dependent events.

[0720] Furthermore, nodes in the different rows can correspond to different nested journey instances that relate to the parent or primary journey instance. For example, nodes in row 4804B can indicate nodes in a first nested journey instance, nodes in row 4804C can indicate nodes in a second nested journey instance, nodes in row 4804D can indicate nodes in a third nested journey instance, and nodes in row 4804E can indicate nodes in a fourth nested journey instance. As such, the journey visualization 4800 can indicate that four nested journey instances are related to event 5.

[0721] As described herein, events of a nested journey instance can be identified and/or categorized based one or more step identifiers and/or one or more pivot identifiers. For example, the events of the nested journey instance indicated by row 4804B can be related based on a first pivot identifier or a common field value for a first pivot identifier field. Similarly, the events of the nested journey instances indicated by rows 4804C, 4804D, and 4804E can be related based on respective pivot identifiers or respective common field values for respective pivot identifier fields. In addition, one or more of the events in each of the nested journey instances can include a field value that matches the field value of event 5 for the pivot ID field.

[0722] In some instances, gluing events can be identified to interrelate the different nested journey instances with the

event 5. In some cases, an arrow between nodes can identify a gluing event. For example, the arrows to nodes A, B, D, and F can indicate that those nodes correspond to gluing events. As also described herein, in some cases, multiple gluing events can be used to relate a nested journey instance to the primary journey instance without the presence of a single event that includes the field value for the pivot ID of the primary journey instance and the field value for the pivot ID of the nested journey instance. For example, a first gluing event can be used to identify the relationship between event 5 and the events of the nested journey instance corresponding to row 4804B and a second gluing event can be used to identify the relationship between the events of the nested journey instance corresponding to row 4804B and the events of the nested journey instance corresponding to row 4804C. However, there may not be a gluing event that explicitly identifies the relationship between event 5 and the events of the nested journey instance corresponding to row 4804C. Notwithstanding, the system 108 can determine that the events of the nested journey instance corresponding to row 4804C are related to event 5 based on the two aforementioned gluing events. In this way, the system 108 can relate the events of the nested journey instance corresponding to row 4804C to event 5 without a gluing event that explicitly relates them.

[0723] Furthermore, as described herein, the different events of each journey instance can be categorized based on one or more step IDs. For example, the event corresponding to node A can have a first field value for a first step ID field and the event corresponding to node C can have a second field value for the second step ID. Similarly, events corresponding to nodes B and E can have different field values for the same step ID field. In this way, the system can categorize the different events in the nested journeys with different steps. Although discussed above with reference to a step ID for each nested journey instance, in some cases, a single step ID can be used for all the nested journey instance and the primary journey instance. Further, in some cases multiple events in the same nested journey can have the same field value for the step ID indicating that a particular step was repeated at a later point in time.

[0724] It will be understood that a variety of visualizations can be used to indicate the relationship between the event 5 and events of related nested journey instances. Further, as indicated above, the visualization 4800 is not limited to events and a journey instance, but can indicate relationships between step instances of journey instances with dependent step instances or between events or steps of journey models with dependent events or steps of journey models.

[0725] Any or all of the features and functions described above can be combined with each other, except to the extent it may be otherwise stated above or to the extent that any such embodiments may be incompatible by virtue of their function or structure, as will be apparent to persons of ordinary skill in the art. Unless contrary to physical possibility, it is envisioned that (i) the methods/steps described herein may be performed in any sequence and/or in any combination, and (ii) the components of respective embodiments may be combined in any manner.

[0726] Although the subject matter has been described in language specific to structural features and/or acts, it is to be understood that the subject matter defined in the appended claims is not necessarily limited to the specific features or acts described above. Rather, the specific features and acts

described above are disclosed as examples of implementing the claims, and other equivalent features and acts are intended to be within the scope of the claims.

[0727] Conditional language, such as, among others, “can,” “could,” “might,” or “may,” unless specifically stated otherwise, or otherwise understood within the context as used, is generally intended to convey that certain embodiments include, while other embodiments do not include, certain features, elements and/or steps. Thus, such conditional language is not generally intended to imply that features, elements and/or steps are in any way required for one or more embodiments or that one or more embodiments necessarily include logic for deciding, with or without user input or prompting, whether these features, elements and/or steps are included or are to be performed in any particular embodiment.

[0728] Unless the context clearly requires otherwise, throughout the description and the claims, the words “comprise,” “comprising,” and the like are to be construed in an inclusive sense, as opposed to an exclusive or exhaustive sense, i.e., in the sense of “including, but not limited to.” As used herein, the terms “connected,” “coupled,” or any variant thereof means any connection or coupling, either direct or indirect, between two or more elements; the coupling or connection between the elements can be physical, logical, or a combination thereof. Additionally, the words “herein,” “above,” “below,” and words of similar import, when used in this application, refer to this application as a whole and not to any particular portions of this application. Where the context permits, words using the singular or plural number may also include the plural or singular number respectively. The word “or” in reference to a list of two or more items, covers all of the following interpretations of the word: any one of the items in the list, all of the items in the list, and any combination of the items in the list. Likewise the term “and/or” in reference to a list of two or more items, covers all of the following interpretations of the word: any one of the items in the list, all of the items in the list, and any combination of the items in the list.

[0729] Conjunctive language such as the phrase “at least one of X, Y and Z,” unless specifically stated otherwise, is otherwise understood with the context as used in general to convey that an item, term, etc. may be either X, Y or Z, or any combination thereof. Thus, such conjunctive language is not generally intended to imply that certain embodiments require at least one of X, at least one of Y and at least one of Z to each be present. Further, use of the phrase “at least one of X, Y or Z” as used in general is to convey that an item, term, etc. may be either X, Y or Z, or any combination thereof.

[0730] In some embodiments, certain operations, acts, events, or functions of any of the algorithms described herein can be performed in a different sequence, can be added, merged, or left out altogether (e.g., not all are necessary for the practice of the algorithms). In certain embodiments, operations, acts, functions, or events can be performed concurrently, e.g., through multi-threaded processing, interrupt processing, or multiple processors or processor cores or on other parallel architectures, rather than sequentially.

[0731] Systems and modules described herein may comprise software, firmware, hardware, or any combination(s) of software, firmware, or hardware suitable for the purposes described. Software and other modules may reside and

execute on servers, workstations, personal computers, computerized tablets, PDAs, and other computing devices suitable for the purposes described herein. Software and other modules may be accessible via local computer memory, via a network, via a browser, or via other means suitable for the purposes described herein. Data structures described herein may comprise computer files, variables, programming arrays, programming structures, or any electronic information storage schemes or methods, or any combinations thereof, suitable for the purposes described herein. User interface elements described herein may comprise elements from graphical user interfaces, interactive voice response, command line interfaces, and other suitable interfaces.

[0732] Further, processing of the various components of the illustrated systems can be distributed across multiple machines, networks, and other computing resources. Two or more components of a system can be combined into fewer components. Various components of the illustrated systems can be implemented in one or more virtual machines, rather than in dedicated computer hardware systems and/or computing devices. Likewise, the data repositories shown can represent physical and/or logical data storage, including, e.g., storage area networks or other distributed storage systems. Moreover, in some embodiments the connections between the components shown represent possible paths of data flow, rather than actual connections between hardware. While some examples of possible connections are shown, any of the subset of the components shown can communicate with any other subset of components in various implementations.

[0733] Embodiments are also described above with reference to flow chart illustrations and/or block diagrams of methods, apparatus (systems) and computer program products. Each block of the flow chart illustrations and/or block diagrams, and combinations of blocks in the flow chart illustrations and/or block diagrams, may be implemented by computer program instructions. Such instructions may be provided to a processor of a general purpose computer, special purpose computer, specially-equipped computer (e.g., comprising a high-performance database server, a graphics subsystem, etc.) or other programmable data processing apparatus to produce a machine, such that the instructions, which execute via the processor(s) of the computer or other programmable data processing apparatus, create means for implementing the acts specified in the flow chart and/or block diagram block or blocks. These computer program instructions may also be stored in a non-transitory computer-readable memory that can direct a computer or other programmable data processing apparatus to operate in a particular manner, such that the instructions stored in the computer-readable memory produce an article of manufacture including instruction means which implement the acts specified in the flow chart and/or block diagram block or blocks. The computer program instructions may also be loaded to a computing device or other programmable data processing apparatus to cause operations to be performed on the computing device or other programmable apparatus to produce a computer implemented process such that the instructions which execute on the computing device or other programmable apparatus provide steps for implementing the acts specified in the flow chart and/or block diagram block or blocks.

[0734] Any patents and applications and other references noted above, including any that may be listed in accompa-

nying filing papers, are incorporated herein by reference. Aspects of the invention can be modified, if necessary, to employ the systems, functions, and concepts of the various references described above to provide yet further implementations of the invention. These and other changes can be made to the invention in light of the above Detailed Description. While the above description describes certain examples of the invention, and describes the best mode contemplated, no matter how detailed the above appears in text, the invention can be practiced in many ways. Details of the system may vary considerably in its specific implementation, while still being encompassed by the invention disclosed herein. As noted above, particular terminology used when describing certain features or aspects of the invention should not be taken to imply that the terminology is being redefined herein to be restricted to any specific characteristics, features, or aspects of the invention with which that terminology is associated. In general, the terms used in the following claims should not be construed to limit the invention to the specific examples disclosed in the specification, unless the above Detailed Description section explicitly defines such terms. Accordingly, the actual scope of the invention encompasses not only the disclosed examples, but also all equivalent ways of practicing or implementing the invention under the claims.

[0735] To reduce the number of claims, certain aspects of the invention are presented below in certain claim forms, but the applicant contemplates other aspects of the invention in any number of claim forms. For example, while only one aspect of the invention is recited as a means-plus-function claim under 35 U.S.C. sec. 112(f) (AIA), other aspects may likewise be embodied as a means-plus-function claim, or in other forms, such as being embodied in a computer-readable medium. Any claims intended to be treated under 35 U.S.C. § 112(f) will begin with the words “means for,” but use of the term “for” in any other context is not intended to invoke treatment under 35 U.S.C. § 112(f). Accordingly, the applicant reserves the right to pursue additional claims after filing this application, in either this application or in a continuing application.

What is claimed is:

1. A method, comprising:
 - causing display of a user interface that includes a plurality of field identifiers associated with a plurality of events that satisfy a query, each event of the plurality of events comprising raw machine data associated with a time stamp;
 - receiving at least one pivot identifier;
 - generating a set of events from the plurality of events based on the at least one pivot identifier;
 - receiving a step identifier;
 - grouping the set of events into one or more subsets of events based on the step identifier, wherein each subset of events represents a step instance; and
 - building a journey instance based on an ordering of the one or more step instances that represent the one or more subsets of events.
2. The method of claim 1, wherein the plurality of field identifiers correspond to fields identified from one or more configuration files associated with the plurality of events.
3. The method of claim 1, further comprising:
 - accessing one or more configuration files associated with the plurality of events; and

identifying a plurality of field definitions in the one or more configuration files, wherein the plurality of field identifiers included in the user interface are based on the plurality of field definitions in the one or more configuration files.

4. The method of claim 1, wherein the plurality of field identifiers correspond to fields identified from one or more configuration files associated with the plurality of events, the method further comprising enabling identification, via the user interface, of one or more fields corresponding to the plurality of field identifiers as the at least one pivot identifier, the step identifier, or an attribute.

5. The method of claim 1, further comprising:

enabling, via a selection of one or more field identifiers of the plurality of field identifiers, selection of one or more fields associated with the plurality of events as the at least one pivot identifier or the step identifier; and based on a selection of a field identifier of the one or more field, causing display of a plurality of field values for a field associated with the field identifier.

6. The method of claim 1, further comprising:

enabling, via a selection of one or more field identifiers of the plurality of field identifiers, selection of one or more fields associated with the plurality of events as the at least one pivot identifier or the step identifier; and identifying a plurality of field values for a field associated with a selected field identifier based on an inverted index associated with the plurality of events; and causing display, on the user interface, of at least a portion of the plurality of field values.

7. The method of claim 1, further comprising causing display of a visualization of the journey instance, wherein the visualization indicates the ordering of the one or more step instances of the journey instance.

8. The method of claim 1, further comprising causing display of a visualization of the journey instance, wherein the visualization indicates a transition between the one or more step instances of the journey instance.

9. The method of claim 1, wherein the set of events is a first set of events and the journey instance is a first journey instance, the method further comprising:

building a plurality of journey instances including the first journey instance based on a plurality of sets of events including the first set of events; and causing display of a visualization of one or more of the plurality of journey instances.

10. The method of claim 1, wherein the set of events is a first set of events and the journey instance is a first journey instance, the method further comprising:

building a plurality of journey instances including the first journey instance based on a plurality of sets of events including the first set of events; filtering the plurality of journey instances based on an identification within one or more of the plurality of journey instances of at least one of a particular step instance, a particular transition to or from the particular step instance, or the particular transition to or from the particular step instance within a particular amount, to generate a filtered group of journey instances; and causing display of a visualization of one or more of the filtered group of journey instances.

11. The method of claim 1, wherein the set of events is a first set of events and the journey instance is a first journey instance, the method further comprising:

- building a plurality of journey instances including the first journey instance based on a plurality of sets of events including the first set of events;
- filtering the plurality of journey instances based on an identification of a particular sequence of step instances within one or more of the plurality of journey instances to generate a filtered group of journey instances, wherein each journey instance in the filtered group of journey instances comprises the same step instances and the same sequence of the same step instances; and causing display of a visualization of one or more of the filtered group of journey instances.
- 12.** The method of claim 1, wherein the set of events is a first set of events and the journey instance is a first journey instance, the method further comprising:
- building a plurality of journey instances including the first journey instance based on a plurality of sets of events including the first set of events; and
 - building a journey model based on the plurality of journey instances.
- 13.** The method of claim 1, wherein the set of events is a first set of events and the journey instance is a first journey instance, the method further comprising:
- building a plurality of journey instances including the first journey instance based on a plurality of sets of events including the first set of events;
 - building a journey model based on the plurality of journey instances; and
 - causing display of a visualization of the journey model, wherein the visualization indicates transitions between steps of the journey model, the steps corresponding to the one or more step instances of one or more of the plurality of journey instances.
- 14.** The method of claim 1, wherein the set of events is a first set of events and the journey instance is a first journey instance, the method further comprising:
- building a plurality of journey instances including the first journey instance based on a plurality of sets of events including the first set of events;
 - filtering the plurality of journey instances based on an identification of a particular step instance within one or more of the plurality of journey instances to generate a filtered group of journey instances; and
 - building a journey model based on the filtered group of journey instances.
- 15.** The method of claim 1, wherein the set of events is a first set of events and the journey instance is a first journey instance, the method further comprising:
- building a plurality of journey instances including the first journey instance based on a plurality of sets of events including the first set of events;
 - receiving an identification of a particular step instance within one or more of the plurality of journey instances;
 - filtering the plurality of journey instances based on an identification of one or more step instances that occur after the particular step instance to generate a filtered group of journey instances; and
 - building a journey model based on the filtered group of journey instances
- 16.** The method of claim 1, wherein the set of events is a first set of events and the journey instance is a first journey instance, the method further comprising:
- building a plurality of journey instances including the first journey instance based on a plurality of sets of events including the first set of events;
 - receiving an identification of a particular step instance within one or more of the plurality of journey instances;
 - filtering the plurality of journey instances based on an identification of one or more step instances that occur before the particular step instance to generate a filtered group of journey instances; and
 - building a journey model based on the filtered group of journey instances
- 17.** The method of claim 1, wherein the set of events is a first set of events and the journey instance is a first journey instance, the method further comprising:
- building a plurality of journey instances including the first journey instance based on a plurality of sets of events including the first set of events;
 - receiving an identification of a particular step instance within one or more of the plurality of journey instances;
 - filtering the plurality of journey instances based on an identification of one or more journey instances that end with the particular step instance to generate a filtered group of journey instances; and
 - building a journey model based on the filtered group of journey instances.
- 18.** The method of claim 1, wherein the set of events is a first set of events and the journey instance is a first journey instance, the method further comprising:
- building a plurality of journey instances including the first journey instance based on a plurality of sets of events including the first set of events;
 - receiving an identification of a particular step instance within one or more of the plurality of journey instances;
 - filtering the plurality of journey instances based on an identification of one or more journey instances that begin with the particular step instance to generate a filtered group of journey instances; and
 - building a journey model based on the filtered group of journey instances.
- 19.** The method of claim 1, wherein the set of events is a first set of events and the journey instance is a first journey instance, the method further comprising building a plurality of journey instances including the first journey instance based on a plurality of sets of events including the first set of events;
- identifying a particular set of step instances that have a particular frequency within the plurality of journey instances;
 - filtering the plurality of journey instances based on an identification of one or more journey instances that include the particular set of step instances to generate a filtered group of journey instances; and
 - building a journey model based on the filtered group of journey instances.
- 20.** The method of claim 1, wherein the set of events is a first set of events and the journey instance is a first journey instance, the method further comprising:
- building a plurality of journey instances including the first journey instance based on a plurality of sets of events including the first set of events;
 - filtering the plurality of journey instances based on an identification of a particular transition between two or

- more step instances within one or more of the plurality of journey instances to generate a filtered group of journey instances; and
 building a journey model based on the filtered group of journey instances.
- 21.** The method of claim 1, wherein the set of events is a first set of events and the journey instance is a first journey instance, the method further comprising:
 building a plurality of journey instances including the first journey instance based on a plurality of sets of events including the first set of events;
 filtering the plurality of journey instances based on an identification of a particular transition between two or more step instances within a particular amount of time within one or more of the plurality of journey instances to generate a filtered group of journey instances; and
 building a journey model based on the filtered group of journey instances.
- 22.** The method of claim 1,
 wherein generating a set of events from the plurality of events based on the at least one pivot identifier comprises generating a plurality of sets of events from the plurality of events based on the at least one pivot identifier,
 wherein grouping the set of events into one or more subsets of events based on the step identifier comprises, grouping each set of events of the plurality of sets of events into one or more subsets of events based on the step identifier,
 wherein building a journey instance based on an ordering of the one or more subsets of events comprises building, for each set of events of the plurality of sets of events, a journey instance based on an ordering of the one or more subsets of events of the each set of events, the method further comprising:
 building a journey model based on the plurality of journey instances.
- 23.** The method of claim 1,
 wherein generating a set of events from the plurality of events based on the at least one pivot identifier comprises generating a plurality of sets of events from the plurality of events based on the at least one pivot identifier,
 wherein grouping the set of events into one or more subsets of events based on the step identifier comprises, grouping each set of events of the plurality of sets of events into one or more subsets of events based on the step identifier,
 wherein building a journey instance based on an ordering of the one or more subsets of events comprises building, for each set of events of the plurality of sets of events, a journey instance based on an ordering of the one or more subsets of events of the each set of events, the method further comprising:
 building a journey model based on the plurality of journey instances; and
- causing display of a visualization of the journey model, wherein the visualization indicates one or more transitions between steps of the journey model, the steps corresponding to the one or more step instances of one or more of the plurality of journey instances.
- 24.** The method of claim 1, wherein the plurality of events are associated with a plurality of heterogeneous data sources, and wherein the plurality of heterogeneous data sources comprise heterogeneous data formats.
- 25.** The method of claim 1, wherein each event of the set of events comprises the same field value for a field associated with the at least one pivot identifier.
- 26.** The method of claim 1, wherein the ordering of the one or more subsets of events is based on a time stamp associated with the one or more subsets of events.
- 27.** The method of claim 1, wherein generating the set of events is further based on the step identifier.
- 28.** The method of claim 1, wherein the user interface includes a plurality of field values for a field associated with at least one of the step identifier or the pivot identifier.
- 29.** A computing system, comprising:
 one or more processing devices configured to:
 cause display of a user interface that includes a plurality of field identifiers associated with a plurality of events that satisfy a query, each event of the plurality of events comprising raw machine data associated with a time stamp;
 receive at least one pivot identifier;
 generate a set of events from the plurality of events based on the at least one pivot identifier;
 receive a step identifier;
 group the set of events into one or more subsets of events based on the step identifier, wherein each subset of events represents a step instance; and
 build a journey instance based on an ordering of the one or more step instances that represent the one or more subsets of events.
- 30.** Non-transitory computer readable media comprising computer-executable instructions that, when executed by a computing system, cause the computing system to:
 cause display of a user interface that includes a plurality of field identifiers associated with a plurality of events that satisfy a query, each event of the plurality of events comprising raw machine data associated with a time stamp;
 receive at least one pivot identifier;
 generate a set of events from the plurality of events based on the at least one pivot identifier;
 receive a step identifier;
 group the set of events into one or more subsets of events based on the step identifier, wherein each subset of events represents a step instance; and
 build a journey instance based on an ordering of the one or more step instances that represent the one or more subsets of events.

* * * * *