



(19) **United States**

(12) **Patent Application Publication**
Lin et al.

(10) **Pub. No.: US 2020/0294948 A1**

(43) **Pub. Date: Sep. 17, 2020**

(54) **FLIP CHIP PACKAGE UTILIZING TRACE BUMP TRACE INTERCONNECTION**

(71) Applicant: **MEDIATEK INC.**, Hsin-Chu (TW)

(72) Inventors: **Tzu-Hung Lin**, Hsinchu City (TW);
Thomas Matthew Gregorich, San Diego, CA (US)

(21) Appl. No.: **16/888,845**

(22) Filed: **May 31, 2020**

Related U.S. Application Data

- (63) Continuation of application No. 16/439,707, filed on Jun. 13, 2019, now Pat. No. 10,707,183, which is a continuation of application No. 13/753,537, filed on Jan. 30, 2013, now Pat. No. 10,354,970, which is a continuation of application No. 13/110,932, filed on May 19, 2011, now Pat. No. 8,390,119.
- (60) Provisional application No. 61/371,291, filed on Aug. 6, 2010.

Publication Classification

- (51) **Int. Cl.**
H01L 23/00 (2006.01)
H01L 23/498 (2006.01)
- (52) **U.S. Cl.**
CPC *H01L 24/17* (2013.01); *H01L 23/49838* (2013.01); *H01L 24/05* (2013.01); *H01L 21/563* (2013.01); *H01L 24/16* (2013.01); *H01L 2224/0401* (2013.01); *H01L 24/13* (2013.01)

(57) **ABSTRACT**

A flip chip package includes a substrate having a die attach surface, and a die mounted on the die attach surface with an active surface of the die facing the substrate. The die includes a base, a passivation layer overlying the base, a topmost metal layer overlying the passivation, and a stress buffering layer overlying the topmost metal layer, wherein at least two openings are disposed in the stress buffering layer to expose portions of the topmost metal layer. The die is interconnected to the substrate through a plurality of conductive pillar bumps on the active surface. At least one of the conductive pillar bumps is electrically connected to one of the exposed portions of the topmost metal layer through one of the at least two openings.

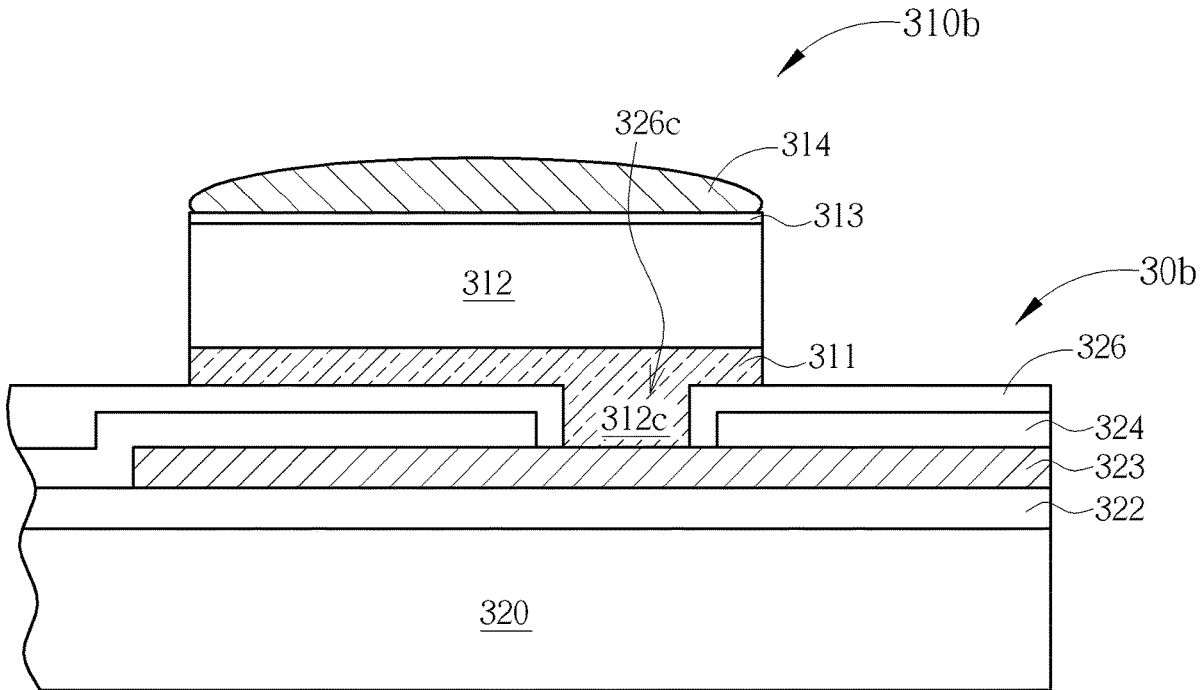

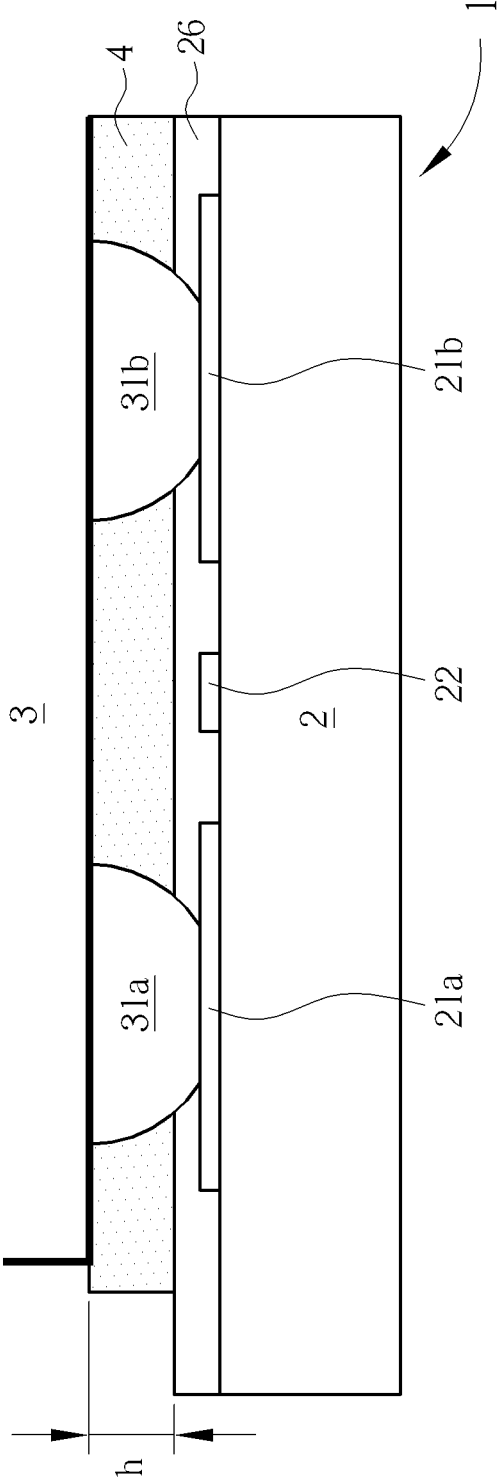

FIG. 1 RELATED ART

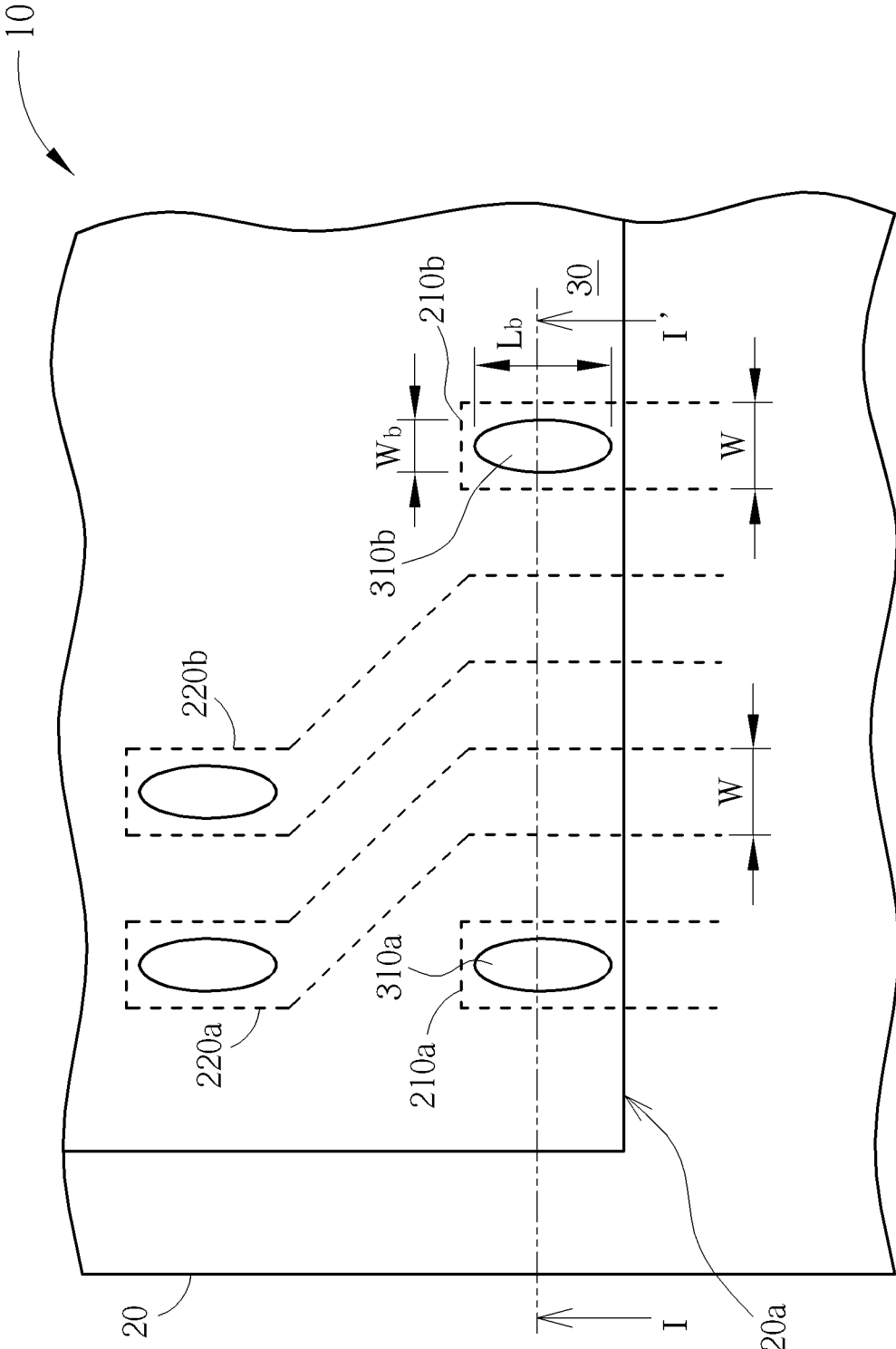

FIG. 2

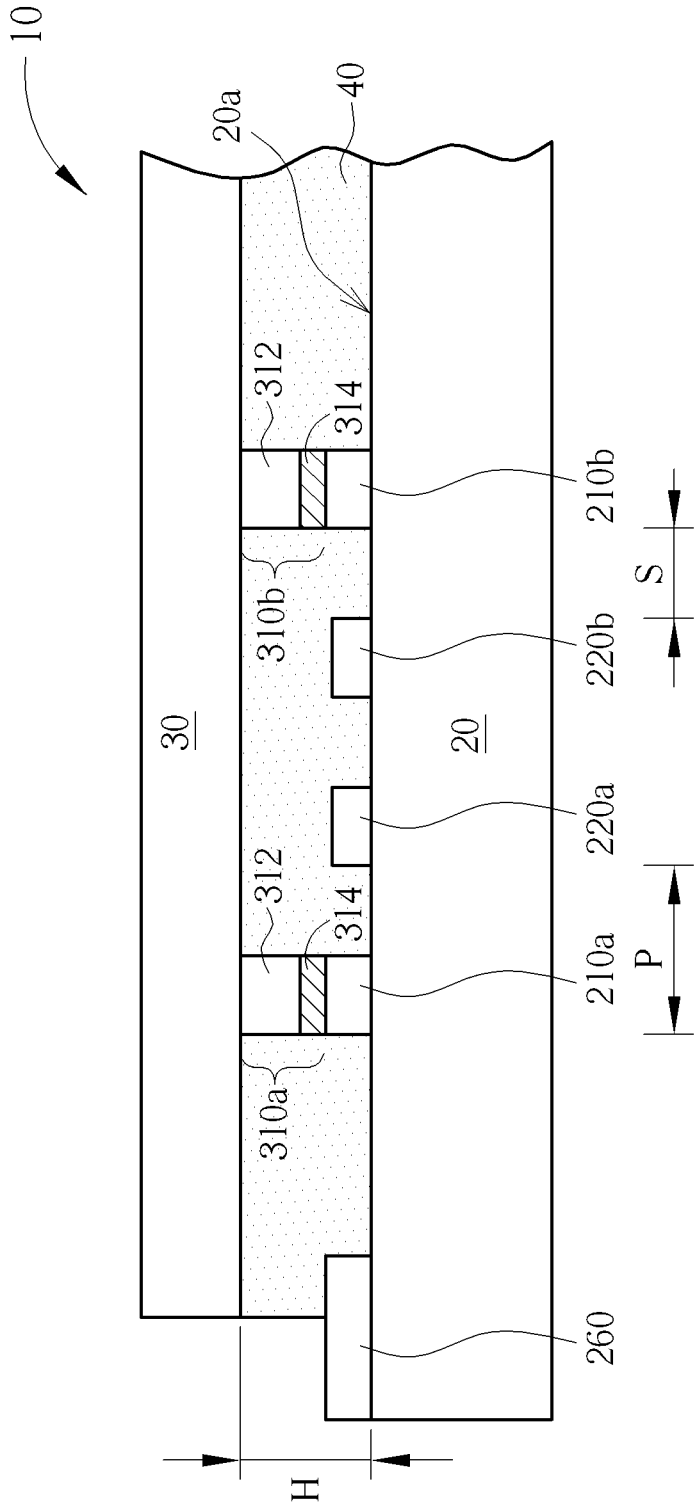

FIG. 3

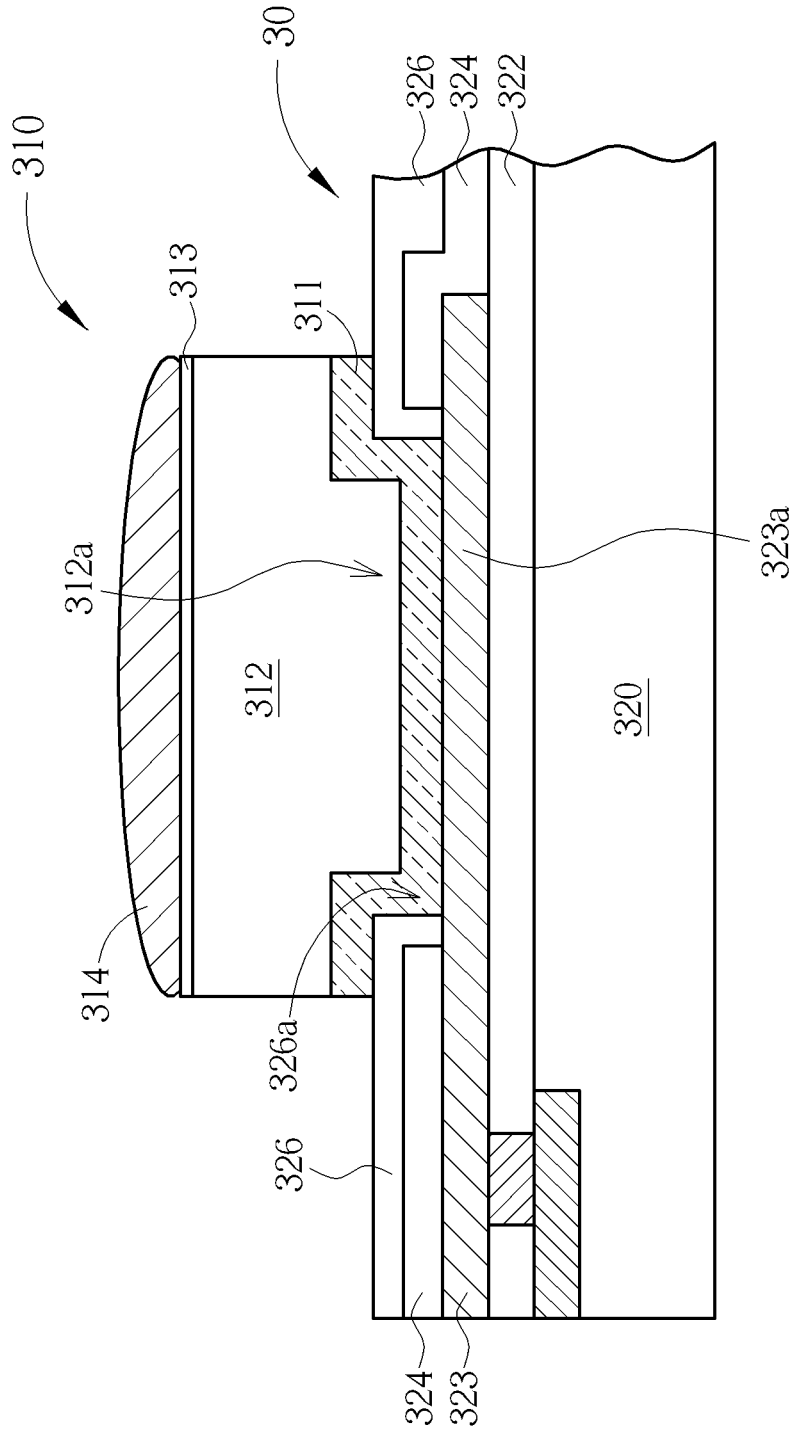

FIG. 4

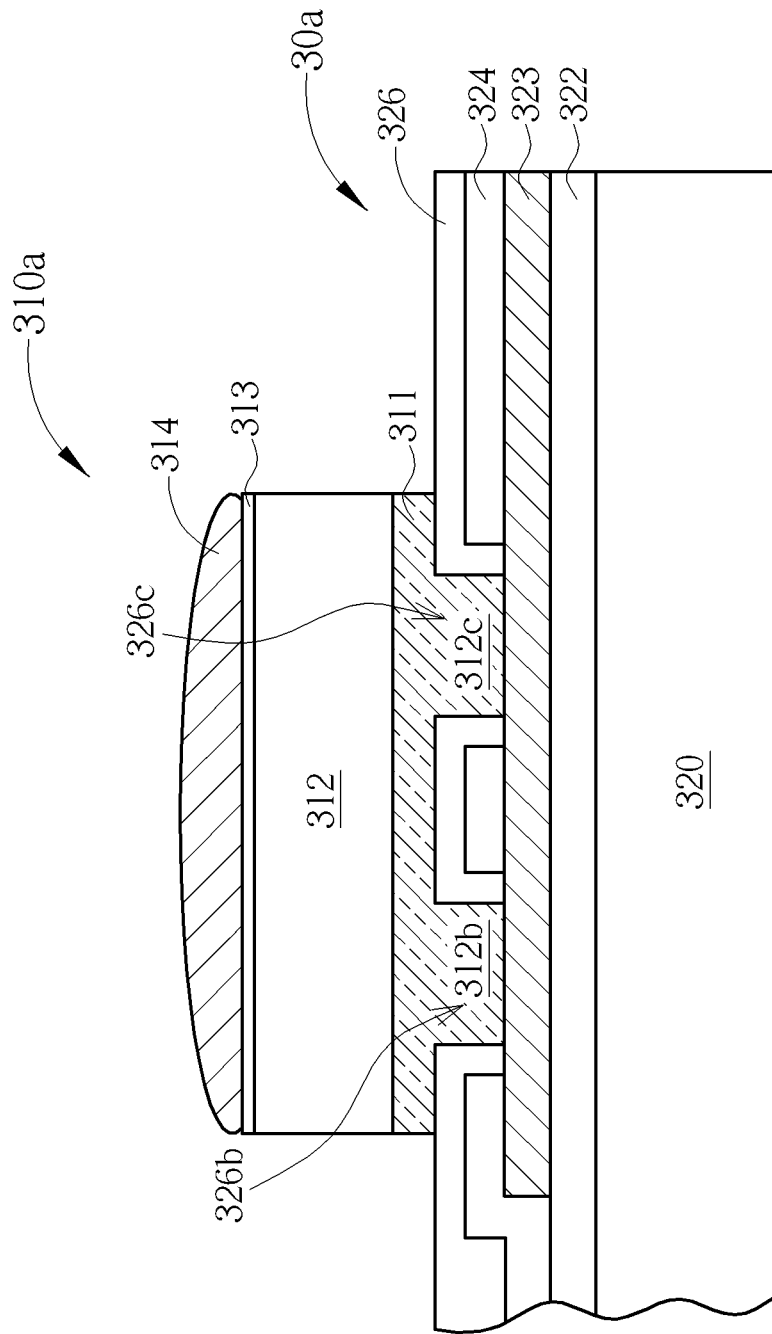

FIG. 5

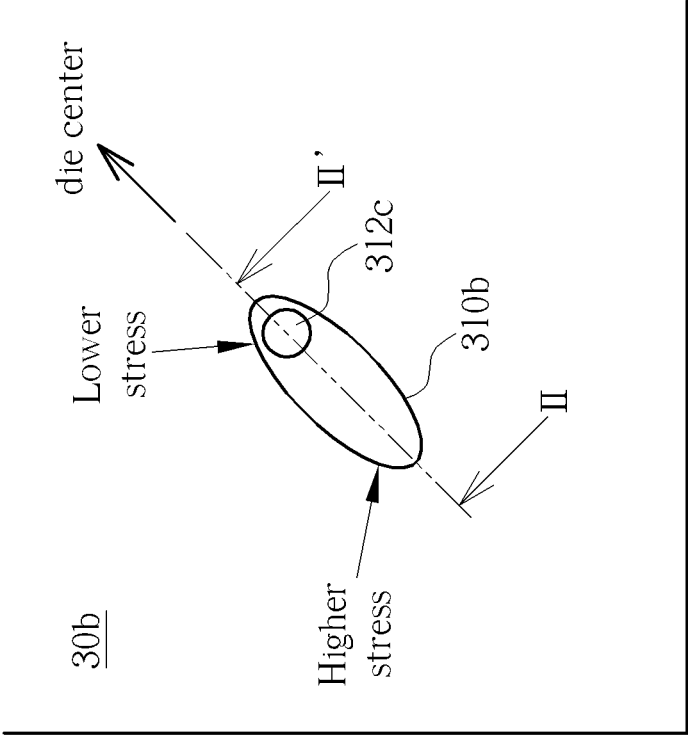

FIG. 6

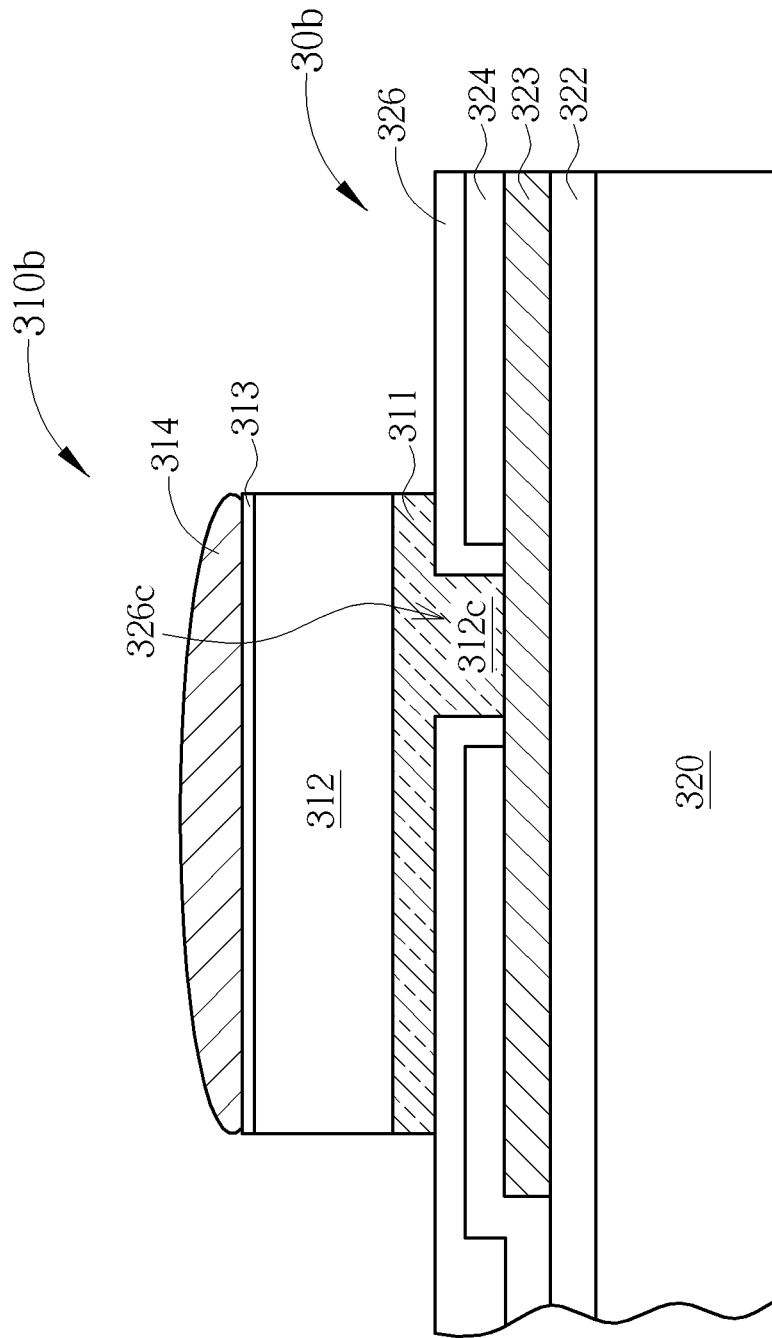

FIG. 7

FLIP CHIP PACKAGE UTILIZING TRACE BUMP TRACE INTERCONNECTION

CROSS REFERENCE TO RELATED APPLICATION

[0001] This is a continuation application of U.S. application Ser. No. 16/439,707, filed Jun. 13, 2019. U.S. application Ser. No. 16/439,707 is a continuation of U.S. application Ser. No. 13/753,537 filed Jan. 30, 2013, which itself is a continuation of U.S. application Ser. No. 13/110,932 filed May 19, 2011, which claims the benefit of U.S. provisional application No. 61/371,291 filed Aug. 6, 2010, which are all hereby incorporated herein by reference in their entireties.

BACKGROUND

1. Field of the Invention

[0002] The present invention relates generally to flip chip technology. More particularly, the present invention relates to a flip chip package utilizing trace bump trace (TBT) interconnection.

2. Description of the Prior Art

[0003] In order to ensure miniaturization and multi-functionality of electronic products or communication devices, semiconductor packages are required to be of small in size, multi-pin connection, high speed, and high functionality. Increased Input-Output (I/O) pin count combined with increased demands for high performance ICs has led to the development of flip chip packages.

[0004] Flip-chip technology uses bumps on chip to interconnect the package media such as package substrate. The flip-chip is bonded face down to the package substrate through the shortest path. These technologies can be applied not only to single-chip packaging, but also to higher or integrated levels of packaging in which the packages are larger and to more sophisticated substrates that accommodate several chips to form larger functional units. The flip-chip technique, using an area array, has the advantage of achieving the higher density of interconnection to the device and a very low inductance interconnection to the package.

[0005] FIG. 1 shows a portion of a conventional flip chip package in a diagrammatic sectional view. As shown in FIG. 1, the conventional flip chip package 1 is made by using a “bump-on-capture pad” (BOC) interconnect scheme. At least two adjacent capture pads 21a and 21b and a metal trace 22 are disposed on a die attach surface of the package substrate 2. A solder mask 26 covers the die attach surface of the package substrate 2. The solder mask 26 has solder mask defined (SMD) openings corresponding to the capture pads 21a and 21b for confining the flow of solder during the interconnection process.

[0006] Interconnection solder bumps 31a and 31b disposed on the active side of the die 3 are joined to the exposed capture pads 21a and 21b respectively. After performing the reflow of the interconnection solder bumps 31a and 31b, an underfill material 4 is typically introduced into the gap with stand-off height h between the substrate 2 and the die 3 to mechanically stabilizing the interconnects.

[0007] One drawback of the above-described prior art is that there is considerable loss of routing space on the top layer of package substrate 2. This is because the width or diameter of the capture pad is typically about the same as the

ball (or bump) diameter, and can be as much as two to four times wider than the trace (or lead) width. Another drawback of the above-described prior art is that the small stand-off height between the die and the package substrate limits the process window, reliability and throughput when performing underfill process in the flip chip assembly flow.

SUMMARY

[0008] It is one object of the invention to provide an improved flip chip package utilizing novel trace bump trace (TBT) interconnection, which is capable of lowering the cost in substrate and widening the process window for flip chip assembly flow.

[0009] To these ends, according to one aspect of the present invention, there is provided a flip chip package including a substrate having a die attach surface, and a die mounted on the die attach surface with an active surface of the die facing the substrate. The die includes a base, a passivation layer overlying the base, a topmost metal layer overlying the passivation, and a stress buffering layer overlying the topmost metal layer, wherein at least two openings are disposed in the stress buffering layer to expose portions of the topmost metal layer. The die is interconnected to the substrate through a plurality of conductive pillar bumps on the active surface. At least one of the conductive pillar bumps is electrically connected to one of the exposed portions of the topmost metal layer through one of the at least two openings.

[0010] According to some embodiments, the at least one of the plurality of conductive pillar bumps has a bump width that is substantially equal to or smaller than a line width of a trace on the die attach surface of the substrate.

[0011] According to some embodiments, the at least one of the plurality of conductive pillar bumps is directly bonded to the trace.

[0012] According to some embodiments, the at least one of the plurality of conductive pillar bumps is oval-shaped from a plan view.

[0013] According to some embodiments, the at least one of the plurality of conductive pillar bumps is composed of a metal stack comprising an UBM layer, a conductive layer, and a solder cap.

[0014] According to some embodiments, the conductive layer has a thickness between 30 μm and 60 μm .

[0015] According to some embodiments, the solder cap has a thickness between 10 μm and 40 μm .

[0016] According to some embodiments, the at least one of the plurality of conductive pillar bumps further comprises a nickel layer between the conductive layer and the solder cap.

[0017] According to some embodiments, the die has a bump pitch between 120 μm and 180 μm .

[0018] According to some embodiments, at least one of the plurality of conductive pillar bumps has a bump orientation that is directed to a center of the die.

[0019] According to some embodiments, the flip chip package further includes an underfill between the die and the substrate.

[0020] According to some embodiments, the underfill comprises capillary underfill (CUF), molded underfill (MUF) or a combination thereof.

[0021] Another aspect of the invention provides a flip chip package including a substrate having a die attach surface, and a die mounted on the die attach surface with an active

surface of the die facing the substrate. The die includes a base, a passivation layer overlying the base, a topmost metal layer overlying the passivation, and a stress buffering layer overlying the topmost metal layer. At least two openings are disposed in the stress buffering layer to expose portions of the topmost metal layer. The die is interconnected to the substrate through a plurality of conductive pillar bumps on the active surface. At least one of the plurality of conductive pillar bumps has an integral plug disposed within one of the at least two openings and on a side closer to a die center.

[0022] According to some embodiments, the at least one of the plurality of conductive pillar bumps has a bump length that is at least two times greater than the line width of the trace.

[0023] According to some embodiments, the at least one of the plurality of conductive pillar bumps is oval-shaped from a plan view.

[0024] According to some embodiments, the at least one of the plurality of conductive pillar bumps is composed of a metal stack comprising an UBM layer, a conductive layer, and a solder cap.

[0025] According to some embodiments, the at least one of the plurality of conductive pillar bumps further comprises a nickel layer between the conductive layer and the solder cap.

[0026] According to some embodiments, the at least one of the plurality of conductive pillar bumps has a bump orientation that is directed to a center of the die.

[0027] According to some embodiments, the flip chip package further includes an underfill between the die and the substrate.

[0028] Another aspect of the invention provides a flip chip package including a substrate having a die attach surface, and a die mounted on the die attach surface with an active surface of the die facing the substrate. The die includes a base, a passivation layer overlying the base, a topmost metal layer overlying the passivation, and a stress buffering layer overlying the topmost metal layer wherein at least one opening is disposed in the stress buffering layer to expose a portion of the topmost metal layer. The opening is disposed on a side closer to a die center. The die is interconnected to the substrate through a plurality of conductive pillar bumps on the active surface. The plurality of conductive pillar bumps is electrically connected to the exposed portion of the topmost metal layer through the opening.

[0029] These and other objectives of the present invention will no doubt become obvious to those of ordinary skill in the art after reading the following detailed description of the preferred embodiment that is illustrated in the various figures and drawings.

BRIEF DESCRIPTION OF THE DRAWINGS

[0030] The accompanying drawings are included to provide a further understanding of the invention, and are incorporated in and constitute a part of this specification. The drawings illustrate embodiments of the invention and, together with the description, serve to explain the principles of the invention. In the drawings:

[0031] FIG. 1 is a schematic, cross-sectional diagram showing a portion of a conventional flip chip package utilizing solder ball interconnection;

[0032] FIG. 2 is a plan view showing a portion of a flip chip package in accordance with one embodiment of this invention;

[0033] FIG. 3 is a partial sectional view taken along line I-I' in FIG. 2;

[0034] FIG. 4 is a schematic, cross-sectional diagram showing the detailed structure of the copper pillar bump on the active surface of the die according to one embodiment of this invention;

[0035] FIG. 5 is a schematic, cross-sectional diagram showing the detailed structure of the copper pillar bump on the active surface of the die according to another embodiment of this invention;

[0036] FIG. 6 is a plan view of an exemplary copper pillar bump on the active surface of the die in accordance with still another embodiment of this invention; and

[0037] FIG. 7 is a schematic, cross-sectional view of the exemplary copper pillar bump taken along line II-II' in FIG. 6.

[0038] It should be noted that all the figures are diagrammatic. Relative dimensions and proportions of parts of the drawings have been shown exaggerated or reduced in size, for the sake of clarity and convenience in the drawings. The same reference signs are generally used to refer to corresponding or similar features in modified and different embodiments.

DETAILED DESCRIPTION

[0039] In the following detailed description of the invention, reference is made to the accompanying drawings which form a part hereof, and in which is shown, by way of illustration, specific embodiments in which the invention may be practiced. These embodiments are described in sufficient detail to enable those skilled in the art to practice the invention. Other embodiments may be utilized and structural, logical, and electrical changes may be made without departing from the scope of the present invention.

[0040] Please refer to FIG. 2 and FIG. 3. FIG. 2 is a plan view showing a portion of a flip chip package in accordance with one embodiment of this invention. FIG. 3 is a partial sectional view taken along line I-I' in FIG. 2. As shown in FIG. 2 and FIG. 3, the flip chip package 10 comprises a package substrate 20 having a die attach surface 20a. A plurality of traces 210a, 210b, 220a and 220b, which are indicated by dotted lines in FIG. 2, are disposed on the die attach surface 20a of the package substrate 20. According to the embodiment, at least one of the traces 210a, 210b, 220a and 220b may have a line width W between 10 μm and 40 μm , such as 25 μm and trace pitch P between 30 μm and 70 μm , such as 50 μm . According to the embodiment, the space S between two adjacent traces is between 10 μm and 40 μm , such as 25 μm .

[0041] The die attach surface 20a can be covered with a solder mask 260. According to the embodiment, the solder mask 260 can be composed of photosensitive material and can be patterned by photolithographic methods to partially expose the traces 210a, 210b, 220a and 220b and a portion of the die attach surface 20a. For example, the solder mask 260 within a predetermined open area that is directly under the die 30 may be removed to form an open solder mask or open solder resist configuration such that the traces 210a, 210b, 220a and 220b are exposed within the predetermined open area.

[0042] A semiconductor die or die 30 is mounted on the die attach surface 20a of the package substrate 20 with the active surface of the die 30 facing the package substrate 20. The circuitry of the die 30 is interconnected to the circuitry

of the package substrate **20** via a novel trace bump trace (TBT) interconnection scheme. The TBT interconnection scheme features a plurality of lathy copper pillar bumps **310a** and **310b** disposed on the active surface of the die **30**. At least one of the copper pillar bumps **310a** and **310b** may be composed of a metal stack comprising an UBM (under bump metallurgy) layer such as a sputtered UBM layer (not explicitly shown), a copper layer **312** such as a plated copper layer **312**, and a solder cap **314**. The detailed structure of copper pillar bumps **310a** and **310b** will be discussed later.

[0043] According to this embodiment, the copper pillar bumps **310a** and **310b** can be oval-shaped from a plan view, as can be best seen in FIG. 2. According to the embodiment, at least one of the copper pillar bumps **310a** and **310b**, when viewed from above, may have a rounded and slightly elongated outline extending along the fine trace. According to the embodiment, the bump width W_b of at least one of the copper pillar bumps, for example, the copper pillar bump **310b**, is substantially equal to or smaller than the line width W of the trace, such as trace **210b**, on the package substrate **20**. In one embodiment, the bump length L_b of at least one of the copper pillar bumps, for example, the copper pillar bump **310b**, may be at least two times greater than the line width W of the trace. By way of example, at least one of the copper pillar bumps **310a** and **310b** may have a bump width W_b between 10 μm and 40 μm , such as 25 μm and a bump length L_b between 40 μm and 80 μm , such as 60 μm . According to the embodiment, the die **30** may have a bump pitch between 120 μm and 180 μm , such as 150 μm .

[0044] Referring to FIG. 3, the copper pillar bumps **310a** and **310b** correspond to the traces **210a** and **210b** on the die attach surface **20a** respectively. During the flip chip assembly, the two copper pillar bumps **310a** and **310b**, for example, are bonded onto the traces **210a** and **210b**, respectively. Due to the small size of the copper pillar bumps **310a** and **310b**, the stress is reduced, the bump-to-trace space is increased and the problem of bump-to-trace bridging can be effectively avoided. Furthermore, an increased routing space can be obtained. After the reflowing process, an underfill material or underfill **40** can be introduced into the gap between the die **30** and the package substrate **20** with an increased stand-off height H . The increased stand-off height H facilitates the underfill process. According to the embodiment, the underfill **40** may be capillary underfill (CUF), molded underfill (MUF) or a combination thereof.

[0045] FIG. 4 is a schematic, cross-sectional diagram showing the detailed structure of the copper pillar bump on the active surface of the die according to one embodiment of this invention. The sectional view of the copper pillar bump is taken along the lengthwise direction of the copper pillar bump. As shown in FIG. 4, the die **30** may include a base **320**, a first passivation layer **322** overlying the base **320**, a topmost metal layer **323** overlying the first passivation layer **322**, a second passivation layer **324** covering the topmost metal layer **323** and the first passivation layer **322**, and a stress buffering layer **326** overlying the second passivation layer **324**. The term "overlying" can mean, but is not limited to, "on" or "over". According to the embodiment, the base **320** may include but not limited to a semiconductor substrate, circuit elements fabricated on a main surface of the semiconductor substrate, inter-layer dielectric (ILD) layers and interconnection. The first passivation layer **322** may comprise but not limited to silicon nitride, silicon oxide, silicon oxynitride or any combination thereof. The second

passivation layer **324** may comprise but not limited to silicon nitride, silicon oxide, silicon oxynitride or any combination thereof. The stress buffering layer **326** may comprise but not limited to polyimide, polybenzoxazole (PBO) or a combination thereof. The topmost metal layer **323** may comprise but not limited to aluminum, copper or alloys thereof. The stress buffering layer **326** may include the second passivation layer **324**.

[0046] An opening **326a** can be formed in the stress buffering layer **326** to expose at least a portion of the topmost metal layer **323**. The opening **326a** can be of any shape. According to the embodiment, the opening **326** may be a lathy, oval-shaped opening elongating along the lengthwise direction of the copper pillar bump. An UBM layer **311** can be formed on the exposed topmost metal layer **323** within the opening **326a**. The UBM layer **311** may also extend onto a top surface of the stress buffering layer **326**. According to the embodiment, the UBM layer **311** may be formed by sputtering methods and may comprise titanium, copper or a combination thereof. For example, the UBM layer **311** may include a titanium layer having a thickness between 500 angstroms and 1500 angstroms such as 1000 angstroms and a copper layer having a thickness between 3000 angstroms and 7000 angstroms such as 5000 angstroms. A copper layer **312** such as an electroplated copper layer can be formed on the UBM layer **311**. According to the embodiment, the copper layer **312** may have a thickness between 30 μm and 60 μm , such as 45 μm . The opening **326** can be filled with the copper layer **312** and the UBM layer **311**, and the copper layer **312** and the UBM layer **311** within the opening **326** may form an integral plug **312a** that electrically couples the copper pillar bump **310** with the underlying topmost metal layer **323**. A solder cap **314** having a thickness between 10 μm and 40 μm , such as 25 μm can be formed on the copper layer **312**. A nickel layer **313** having a thickness between 1 μm and 5 μm , such as 3 μm may be formed between the copper layer **312** and the solder cap **314**. The copper layer, such as copper layer **312**, may be a part of a re-distribution layer (RDL) or may be fabricated concurrently with the RDL.

[0047] FIG. 5 is a schematic, cross-sectional diagram showing the detailed structure of the copper pillar bump on the active surface of the die according to another embodiment of this invention. Likewise, the sectional view of the copper pillar bump is taken along the lengthwise direction of the copper pillar bump. As shown in FIG. 5, the die **30a** may include a base **320**, a first passivation layer **322** overlying the base **320**, a topmost metal layer **323** overlying the first passivation layer **322**, a second passivation layer **324** covering the topmost metal layer **323** and the first passivation layer **322**, and a stress buffering layer **326** overlying the second passivation layer **324**. According to the embodiment, the base **320** may include but not limited to a semiconductor substrate, circuit elements fabricated on a main surface of the semiconductor substrate, inter-layer dielectric (ILD) layers and interconnection. Two openings **326b** and **326c** can be formed in the stress buffering layer **326** to expose portions of the topmost metal layer **323**. The openings **326b** and **326c** can be of any shape. An UBM layer **311** can be formed on the exposed topmost metal layer **323** within the openings **326b** and **326c**. The UBM layer **311** may fill the openings **326b** and **326c** and may extend onto a top surface of the stress buffering layer **326**. According to the embodiment, the UBM layer **311** may be formed by sputtering

methods and may comprise titanium, copper or a combination thereof. The UBM layer 311 may include a titanium layer having a thickness between 500 angstroms and 1500 angstroms such as 1000 angstroms and a copper layer having a thickness between 3000 angstroms and 7000 angstroms such as 5000 angstroms. A copper layer 312 such as an electroplated copper layer 312 can be formed on the UBM layer 311. At least the UBM layer 311 within the openings 326b and 326c may form dual integral plugs 312b and 312c that electrically couple the copper pillar bump 310a with the underlying topmost metal layer 323. A solder cap 314 can be formed on the copper layer 312. A nickel layer 313 may be formed between the copper layer 312 and the solder cap 314.

[0048] The bump orientation is another feature of the invention. FIG. 6 is a plan view showing an exemplary bump orientation on the active surface of the die in accordance with still another embodiment of this invention, and FIG. 7 is a schematic, cross-sectional view of the exemplary copper pillar bump taken along line II-IF in FIG. 6, wherein like numeral numbers designate like regions, layers or elements. FIG. 6 is a partial view of a die corner and only one bump is shown for the sake of simplicity. As shown in FIG. 6, the copper pillar bump 310b in this embodiment is oval-shaped from a plan view and has a rounded and slightly elongated outline extending along the lengthwise direction of the bump. In this embodiment, the lengthwise direction, namely the bump orientation, of the copper pillar bump 310b is directed to the center of the die 30b. According to the embodiment, the copper pillar bump 310b has an asymmetric plug configuration along the lengthwise direction of the bump. More specifically, an integral plug 312c is disposed on the lower stress side as indicated by the arrow, while on the higher stress side that is farther away from the die center, no plug is provided.

[0049] The detailed structure of the asymmetric plug configuration of the copper pillar bump 310b on the die 30b can be seen in FIG. 7. As shown in FIG. 7, likewise, the die 30b comprises a base 320, a first passivation layer 322 overlying the base 320, a topmost metal layer 323 overlying the first passivation layer 322, a second passivation layer 324 covering the topmost metal layer 323 and the first passivation layer 322, and a stress buffering layer 326 overlying the second passivation layer 324. According to the embodiment, the base 320 may include but not limited to a semiconductor substrate, circuit elements fabricated on a main surface of the semiconductor substrate, inter-layer dielectric (ILD) layers and interconnection. One opening 326c is formed on the lower stress side, i.e., the side that is closer to the die center, in the stress buffering layer 326 to expose a portion of the topmost metal layer 323. The opening 326c can be of any shape. An UBM layer 311 can be formed on the exposed topmost metal layer 323 within the opening 326c. The UBM layer 311 may fill the opening 326c and may extend onto a top surface of the stress buffering layer 326. According to the embodiment, the UBM layer 311 may be formed by sputtering methods and may comprise titanium, copper or a combination thereof. The UBM layer 311 may include a titanium layer having a thickness between 500 angstroms and 1500 angstroms such as 1000 angstroms and a copper layer having a thickness between 3000 angstroms and 7000 angstroms such as 5000 angstroms. A copper layer 312 such as an electroplated copper layer can be formed on the UBM layer 311. At least the UBM layer 311 within the opening

326c may form an integral plug 312c that electrically couples the copper pillar bump 310b with the underlying topmost metal layer 323. A solder cap 314 can be formed on the copper layer 312. A nickel layer 313 may be formed between the copper layer 312 and the solder cap 314. Since the integrity of the stress buffering layer 326 on the higher stress side, i.e., the side that is farther away from the die center, is not damaged by the plug and via opening, the underlying extra-low k (ELK) dielectric or ultra-low k (ULK) dielectric in the base 320 can be effectively protected against the stress due to, for example, thermal expansion or wafer warpage. It is another advantage to use such bump orientation as depicted in FIG. 6 and FIG. 7 because a better routing ability can be obtained. With such orientation, the space between two adjacent bumps can be increased such that more traces can pass therethrough.

[0050] Those skilled in the art will readily observe that numerous modifications and alterations of the device and method may be made while retaining the teachings of the invention. Accordingly, the above disclosure should be construed as limited only by the metes and bounds of the appended claims.

What is claimed is:

1. A flip chip package, comprising:

- a substrate having a die attach surface; and
- a die mounted on the die attach surface with an active surface of the die facing the substrate, wherein the die comprises:
 - a base;
 - a passivation layer overlying the base;
 - a topmost metal layer overlying the passivation layer; and
 - a stress buffering layer overlying the topmost metal layer, wherein at least two openings are disposed in the stress buffering layer to expose portions of the topmost metal layer,

wherein the die is interconnected to the substrate through a plurality of conductive pillar bumps on the active surface, and at least one of the conductive pillar bumps is electrically connected to one of the exposed portions of the topmost metal layer through one of the at least two openings.

2. The flip chip package according to claim 1, wherein the at least one of the plurality of conductive pillar bumps has a bump width that is substantially equal to or smaller than a line width of a trace on the die attach surface of the substrate.

3. The flip chip package according to claim 2, wherein the at least one of the plurality of conductive pillar bumps is directly bonded to the trace.

4. The flip chip package according to claim 1, wherein the at least one of the plurality of conductive pillar bumps is oval-shaped from a plan view.

5. The flip chip package according to claim 1, wherein the at least one of the plurality of conductive pillar bumps is composed of a metal stack comprising an UBM layer, a conductive layer, and a solder cap.

6. The flip chip package according to claim 5, wherein the conductive layer has a thickness between 30 μm and 60 μm .

7. The flip chip package according to claim 5, wherein the solder cap has a thickness between 10 μm and 40 μm .

8. The flip chip package according to claim 5, wherein the at least one of the plurality of conductive pillar bumps further comprises a nickel layer between the conductive layer and the solder cap.

9. The flip chip package according to claim 1 wherein the die has a bump pitch between 120 μm and 180 μm .

10. The flip chip package according to claim 1, wherein at least one of the plurality of conductive pillar bumps has a bump orientation that is directed to a center of the die.

11. The flip chip package according to claim 1, further comprising an underfill between the die and the substrate.

12. The flip chip package according to claim 11, wherein the underfill comprises capillary underfill (CUF), molded underfill (MUF) or a combination thereof.

13. A flip chip package, comprising:

a substrate having a die attach surface; and

a die mounted on the die attach surface with an active surface of the die facing the substrate, wherein the die comprises:

a base;

a passivation layer overlying the base;

a topmost metal layer overlying the passivation layer; and

a stress buffering layer overlying the topmost metal layer, wherein at least two openings are disposed in the stress buffering layer to expose portions of the topmost metal layer,

wherein the die is interconnected to the substrate through a plurality of conductive pillar bumps on the active surface, and at least one of the plurality of conductive pillar bumps has an integral plug disposed within one of the at least two openings and on a side closer to a die center.

14. The flip chip package according to claim 13, wherein the at least one of the plurality of conductive pillar bumps has a bump length that is at least two times greater than the line width of the trace.

15. The flip chip package according to claim 13, wherein the at least one of the plurality of conductive pillar bumps is oval-shaped from a plan view.

16. The flip chip package according to claim 13, wherein the at least one of the plurality of conductive pillar bumps is composed of a metal stack comprising an UBM layer, a conductive layer, and a solder cap.

17. The flip chip package according to claim 16, wherein the at least one of the plurality of conductive pillar bumps further comprises a nickel layer between the conductive layer and the solder cap.

18. The flip chip package according to claim 13, wherein the at least one of the plurality of conductive pillar bumps has a bump orientation that is directed to a center of the die.

19. The flip chip package according to claim 13 further comprising an underfill between the die and the substrate.

20. A flip chip package, comprising:

a substrate having a die attach surface; and

a die mounted on the die attach surface with an active surface of the die facing the substrate, wherein the die comprises:

a base;

a passivation layer overlying the base;

a topmost metal layer overlying the passivation layer; and

a stress buffering layer overlying the topmost metal layer wherein at least one opening is disposed in the stress buffering layer to expose a portion of the topmost metal layer, wherein the opening is disposed on a side closer to a die center, wherein the die is interconnected to the substrate through a plurality of conductive pillar bumps on the active surface, and the plurality of conductive pillar bumps is electrically connected to the exposed portion of the topmost metal layer through the opening.

* * * * *