



US 20210265728A1

(19) **United States**

(12) **Patent Application Publication**
Thomas et al.

(10) **Pub. No.: US 2021/0265728 A1**

(43) **Pub. Date: Aug. 26, 2021**

(54) **REMOTE ELECTRONIC TILT BASE
STATION ANTENNAS HAVING ADJUSTABLE
RET LINKAGES**

Publication Classification

(71) Applicant: **CommScope Technologies LLC**,
Hickory, NC (US)

(51) **Int. Cl.**
H01Q 3/32 (2006.01)
H01Q 9/28 (2006.01)
H01Q 5/48 (2006.01)
H01Q 25/00 (2006.01)
H01Q 1/24 (2006.01)

(72) Inventors: **Sean Gregory Thomas**, McKinney, TX
(US); **Chongli Yang**, Suzhou, Jiangsu
(CN); **Guomin Ding**, Suzhou, Jiangsu
(CN); **Junfeng Yu**, Suzhou, Jiangsu
(CN); **Zhaohui Liu**, Suzhou, Jiangsu
(CN)

(52) **U.S. Cl.**
CPC *H01Q 3/32* (2013.01); *H01Q 9/285*
(2013.01); *H01Q 1/246* (2013.01); *H01Q*
25/001 (2013.01); *H01Q 5/48* (2015.01)

(21) Appl. No.: **17/252,332**

(57) **ABSTRACT**

(22) PCT Filed: **Jun. 27, 2019**

(86) PCT No.: **PCT/US2019/039377**

§ 371 (c)(1),

(2) Date: **Dec. 15, 2020**

Related U.S. Application Data

(60) Provisional application No. 62/696,996, filed on Jul.
12, 2018.

A base station antenna includes a remote electronic tilt (“RET”) actuator, a phase shifter having a moveable element and a mechanical linkage extending between the RET actuator and the phase shifter. The mechanical linkage includes an adjustable RET linkage that has a first link that has a first connection element, a second link that has a second connection element and a connecting member that includes at least a third link. The adjustable RET linkage includes at least a first hinge and a second hinge.

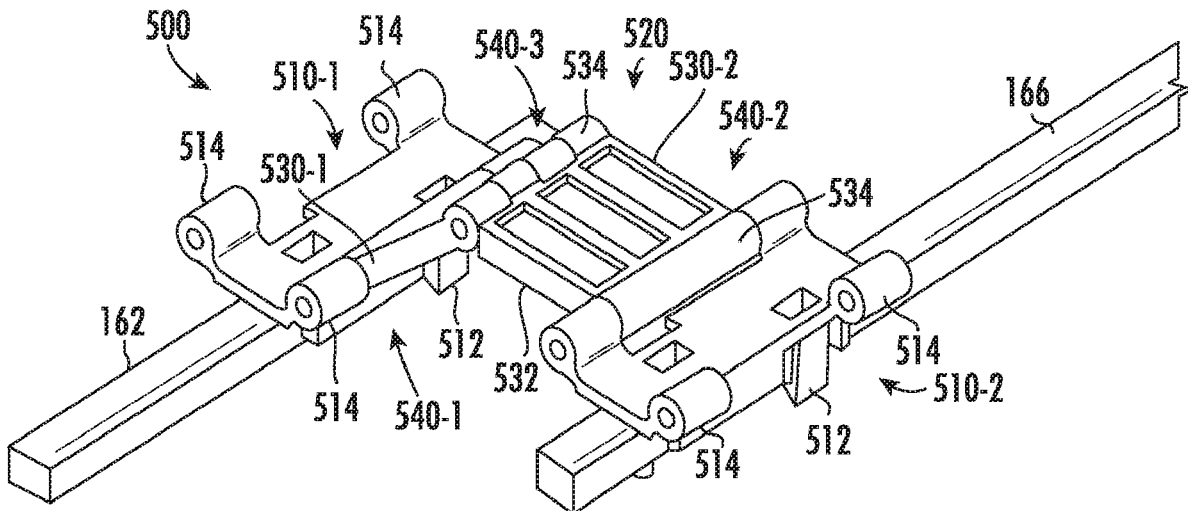

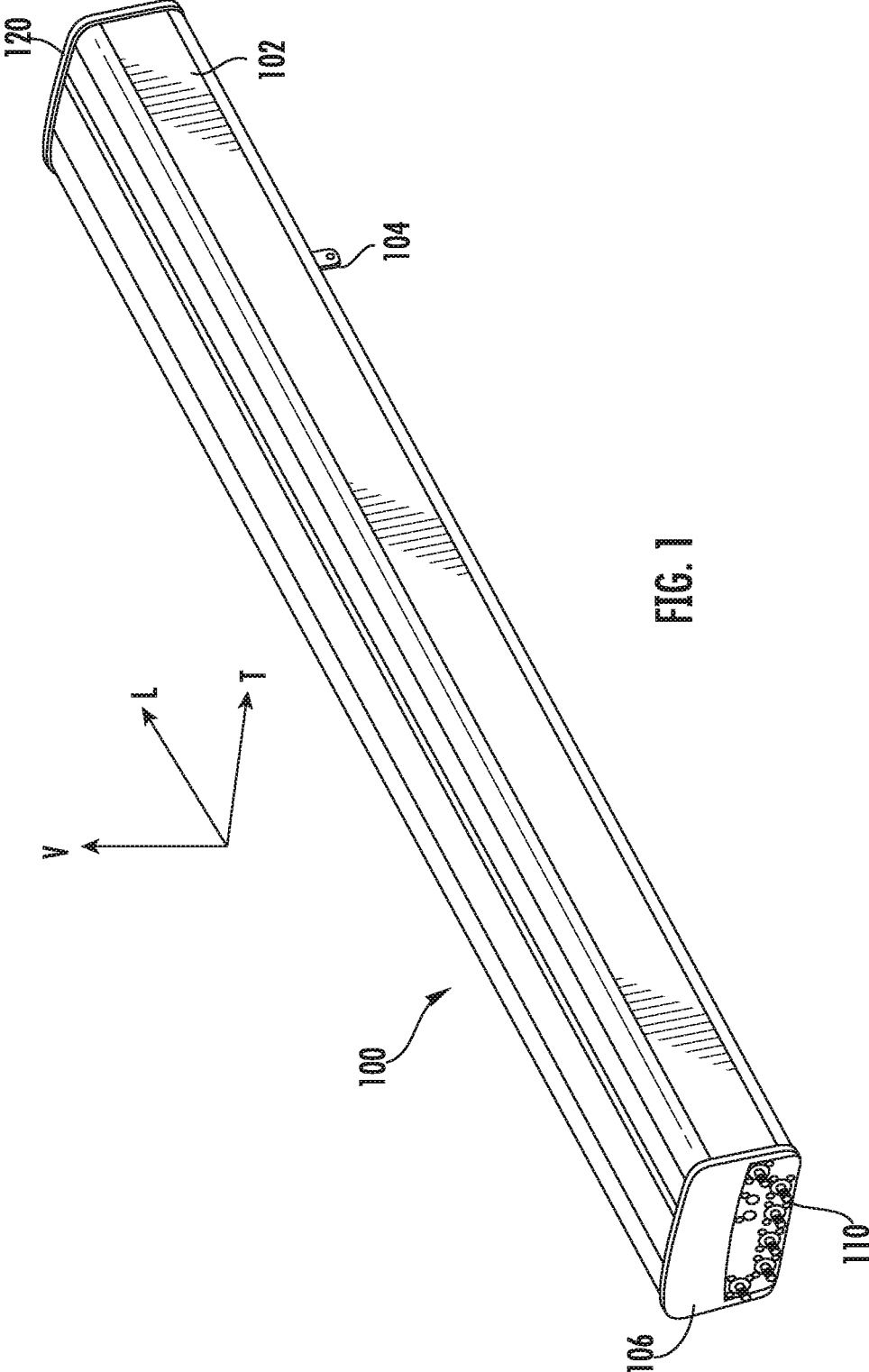

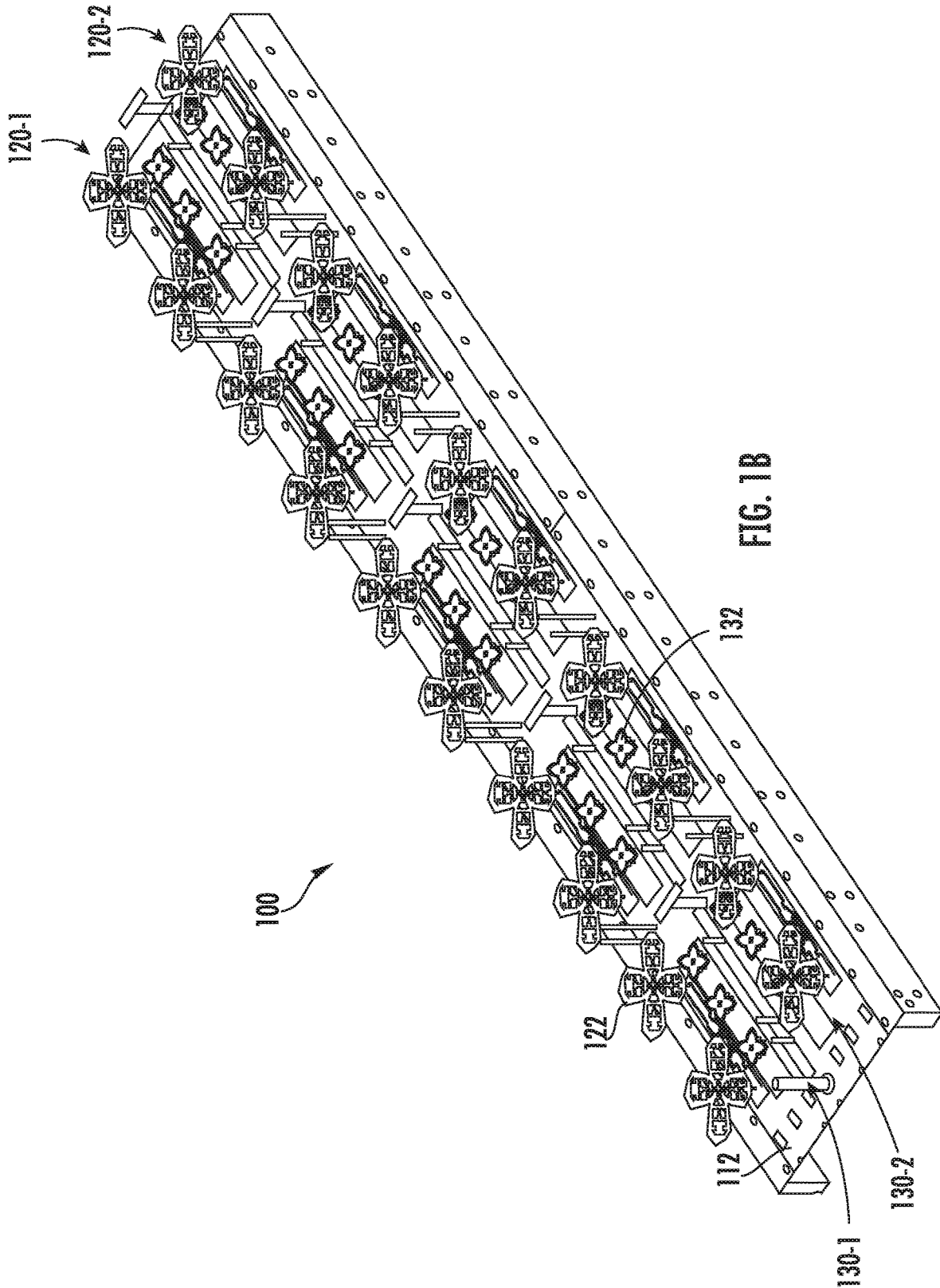

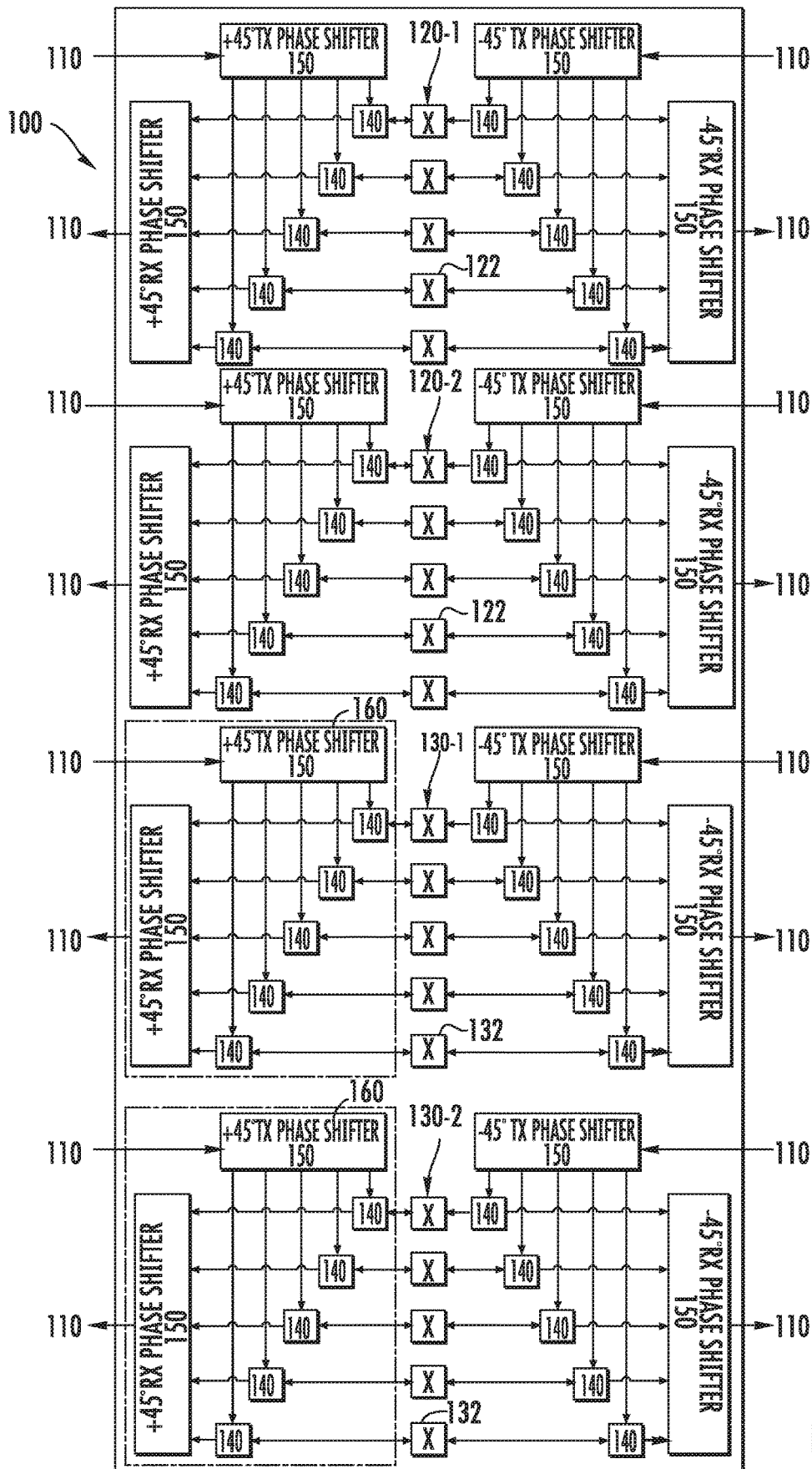

FIG. 2

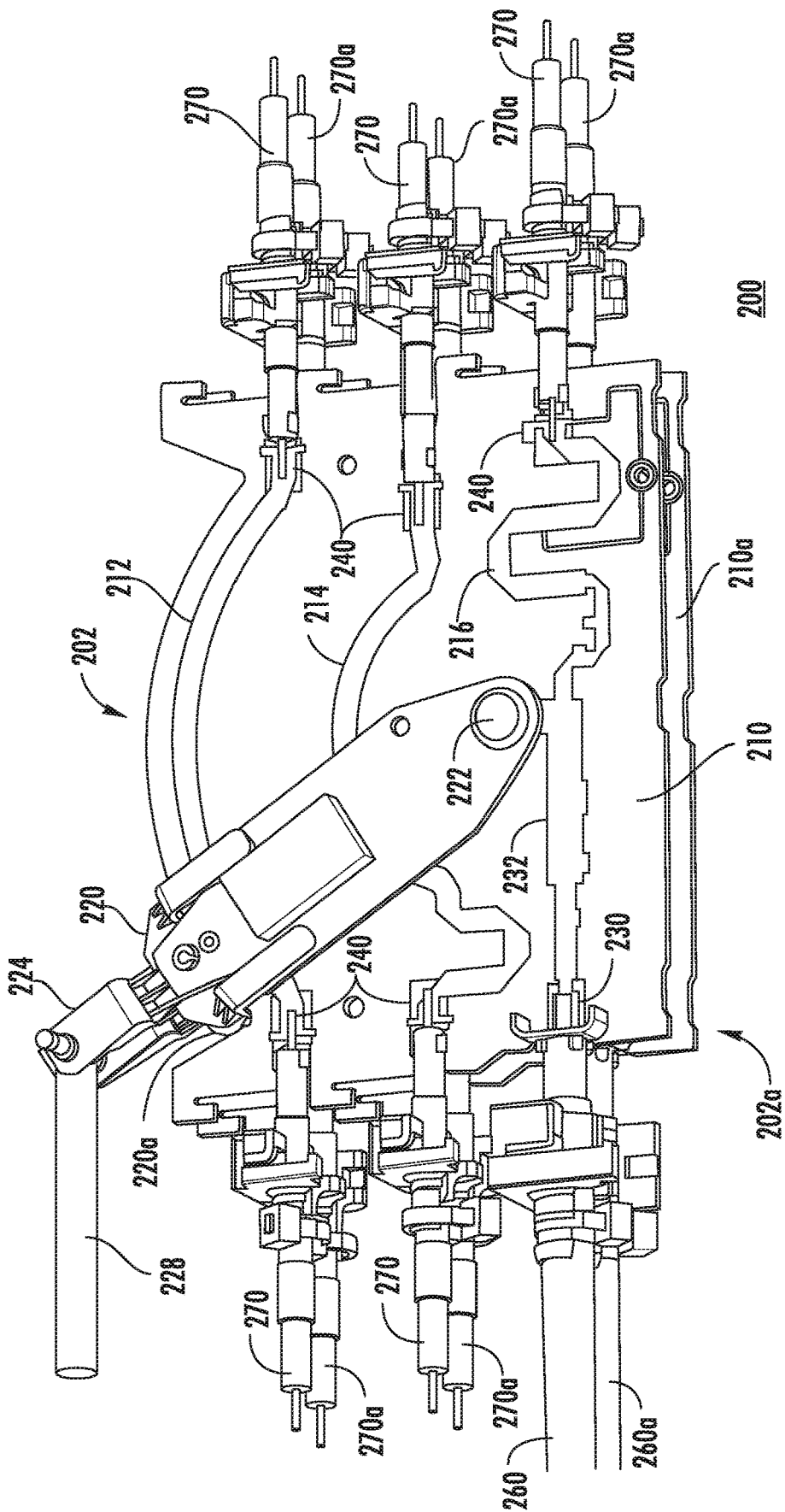

FIG. 3

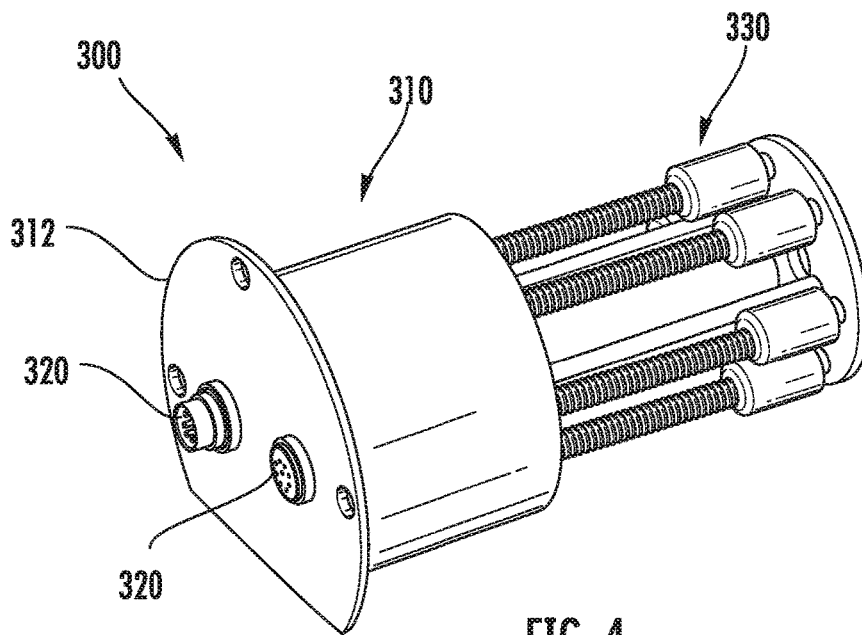

FIG. 4

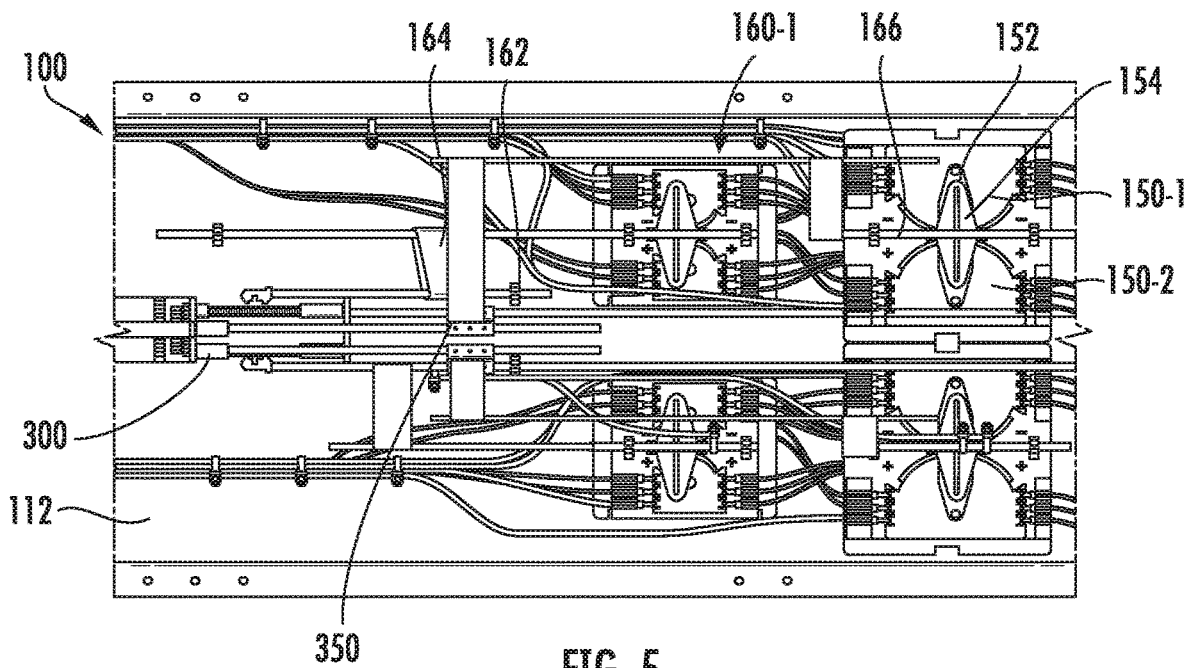

FIG. 5

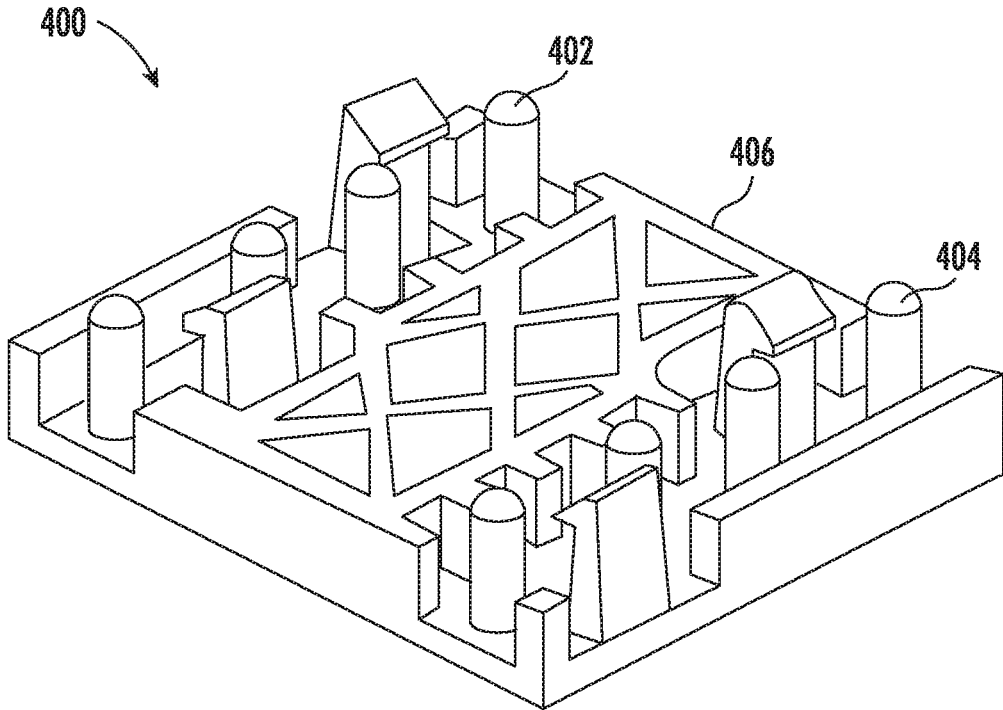

FIG. 6A

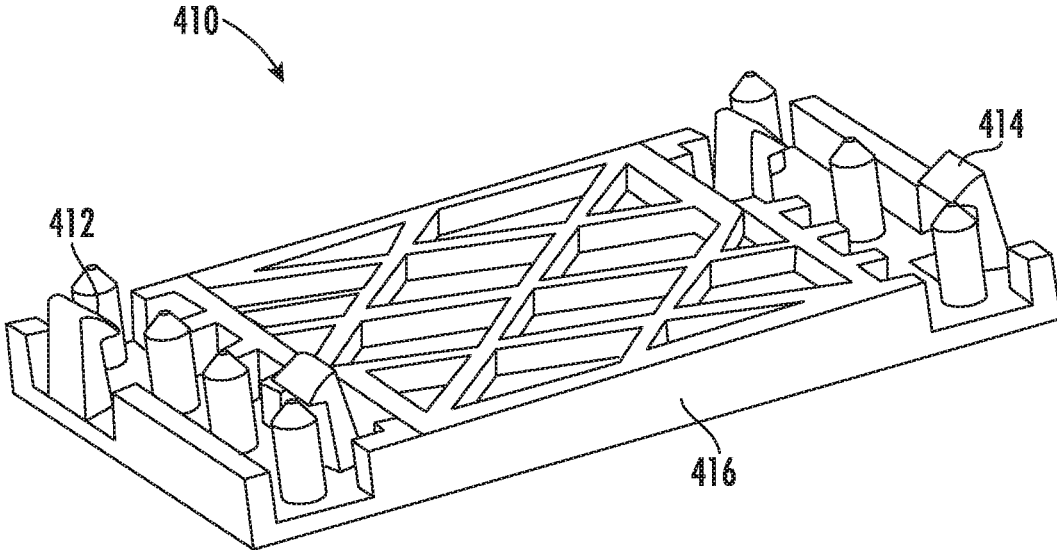

FIG. 6B

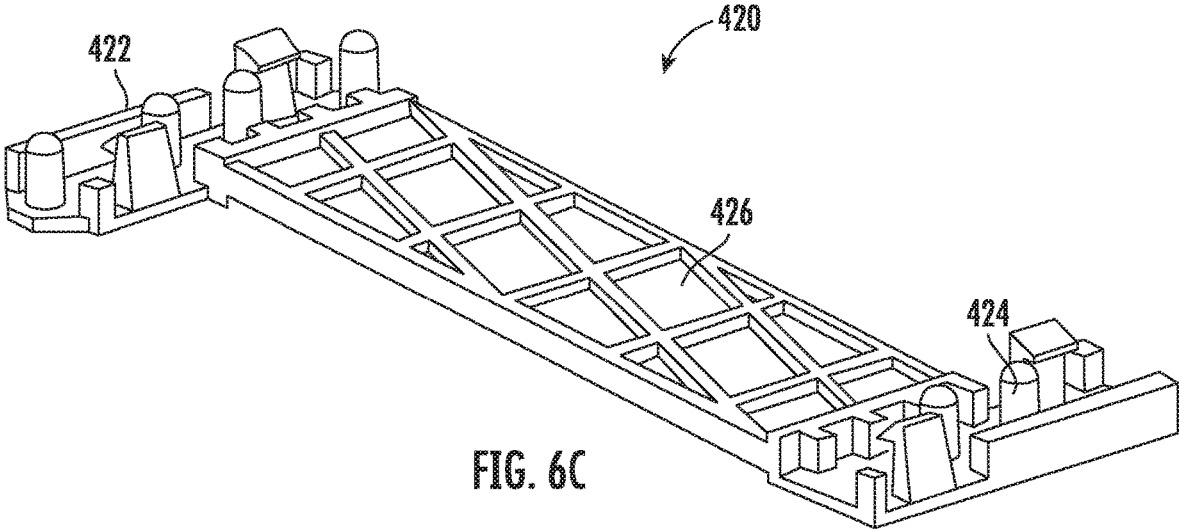

FIG. 6C

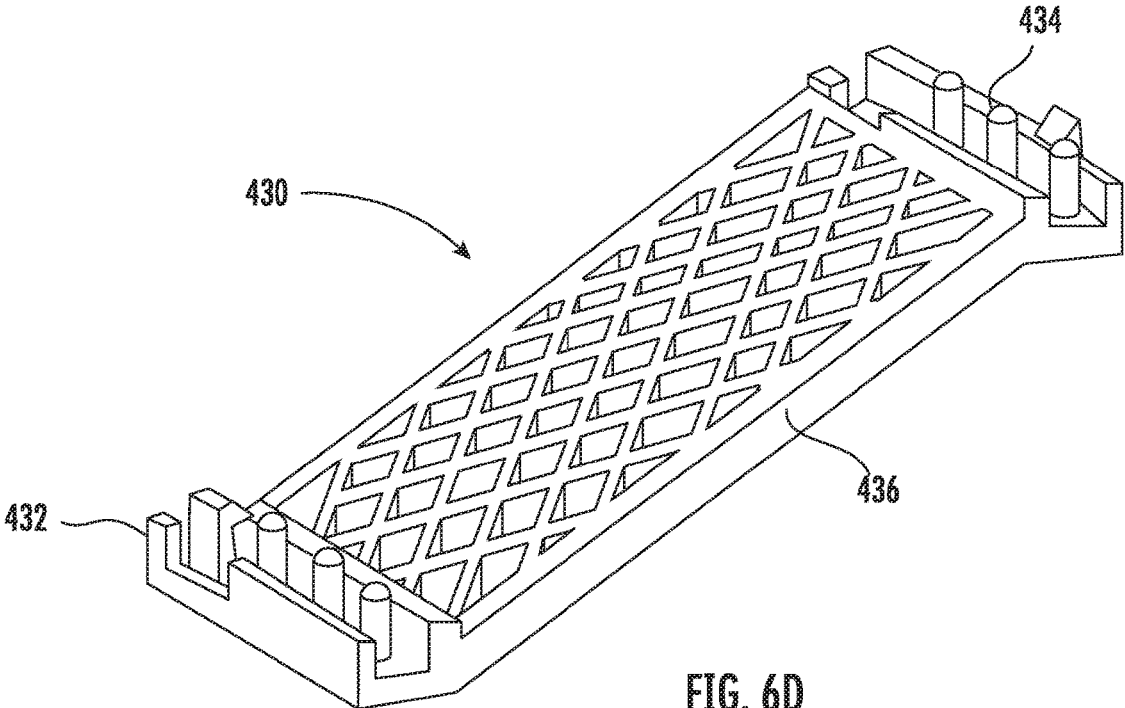

FIG. 6D

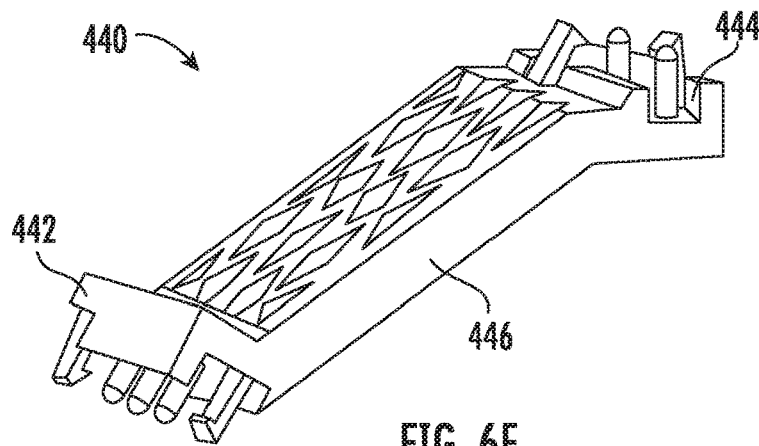

FIG. 6E

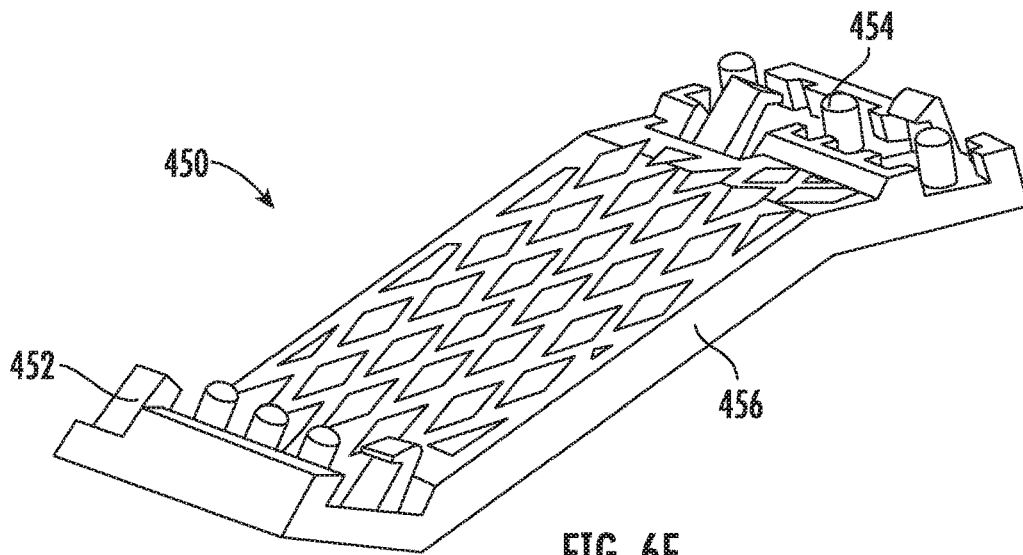

FIG. 6F

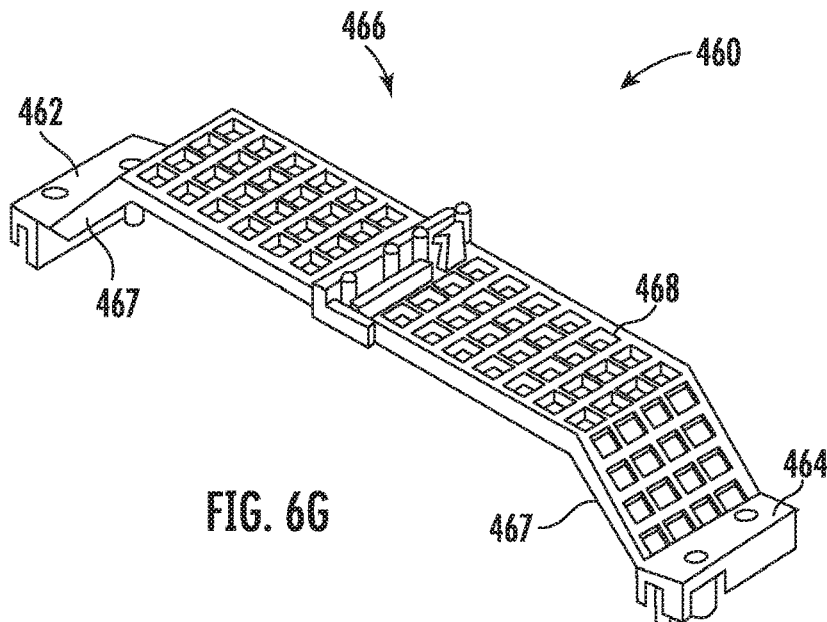

FIG. 6G

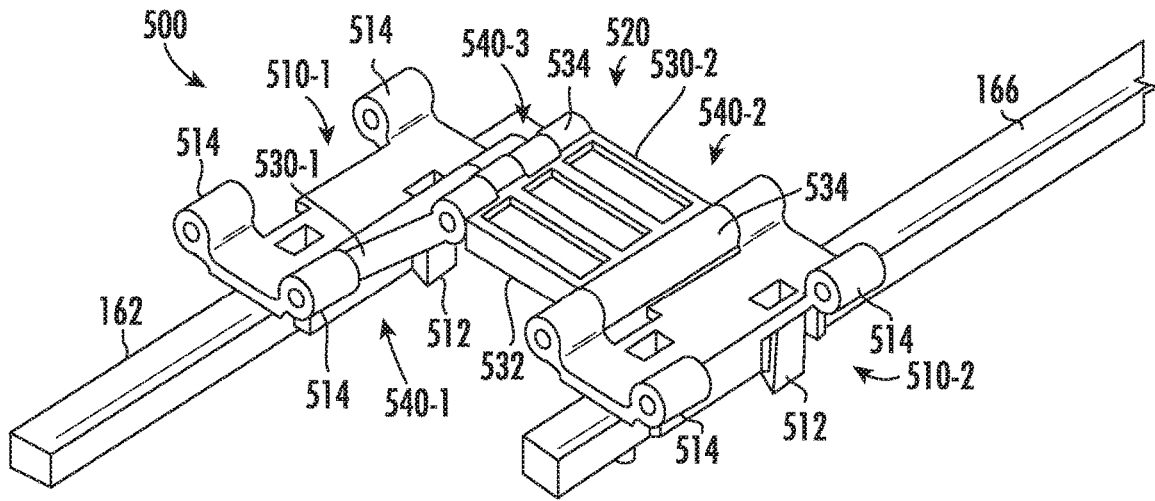

FIG. 7

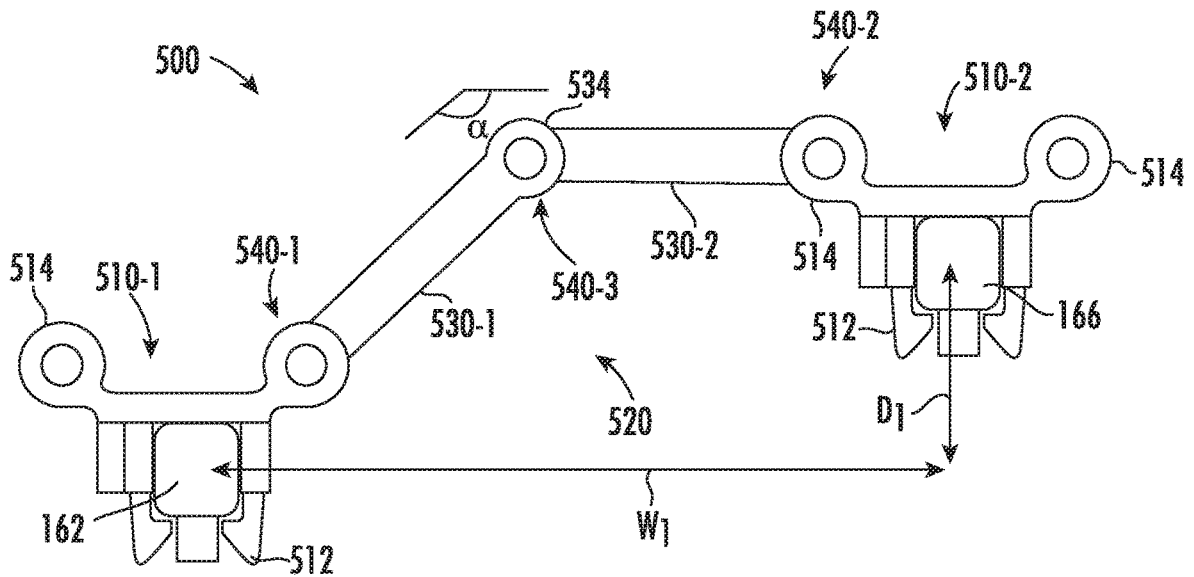

FIG. 8A

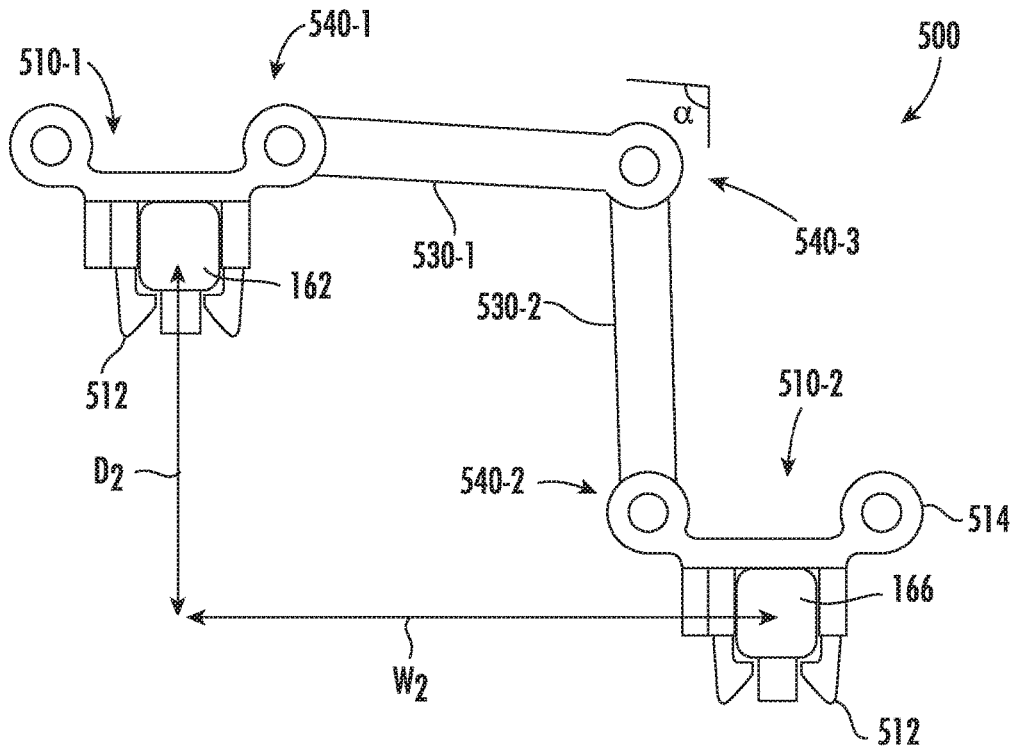

FIG. 8B

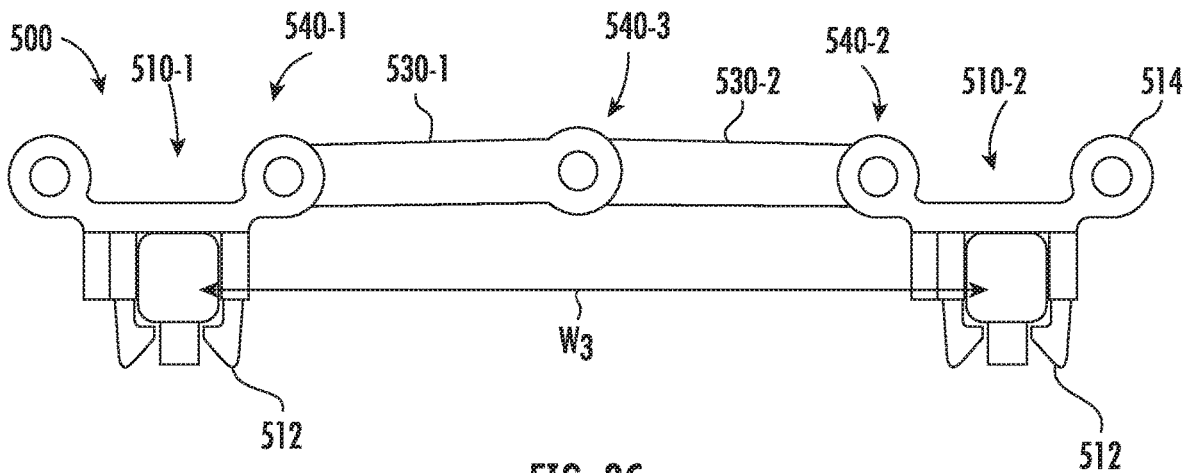
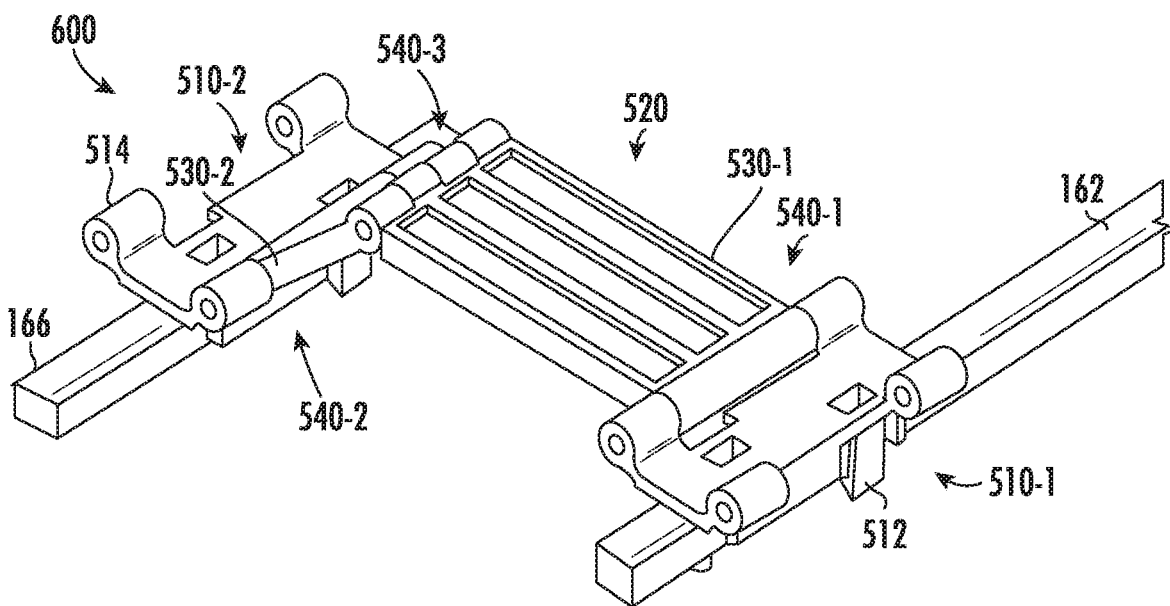
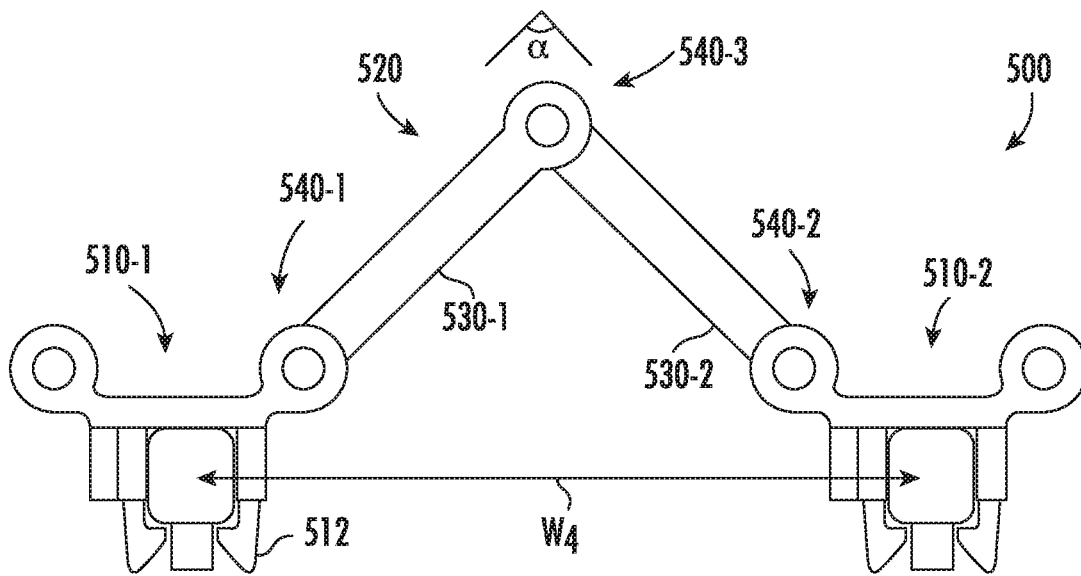

FIG. 8C



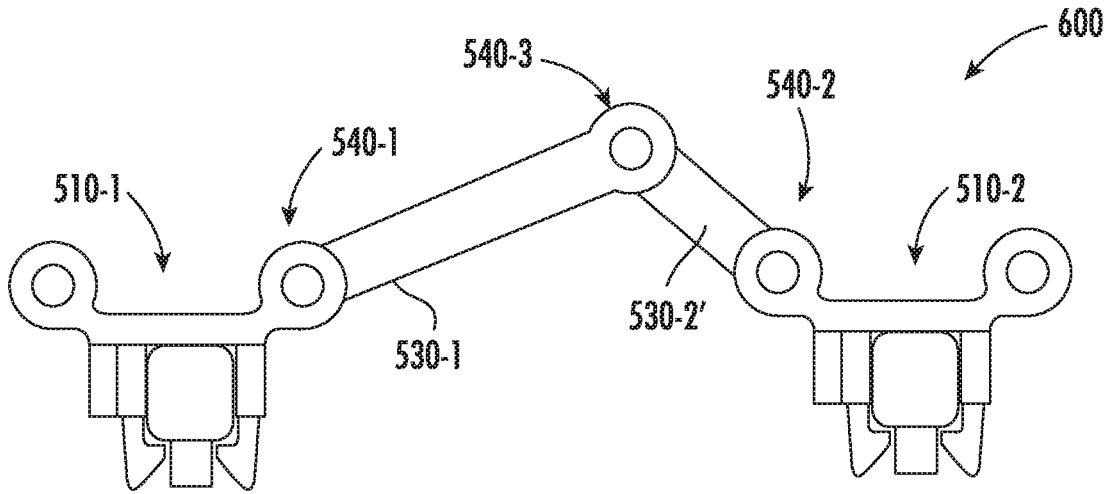

FIG. 9B

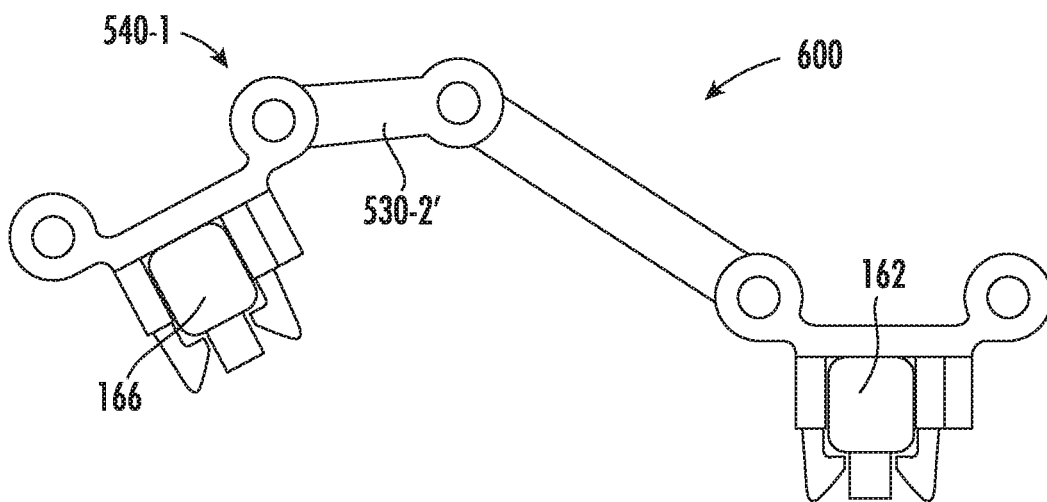

FIG. 10A

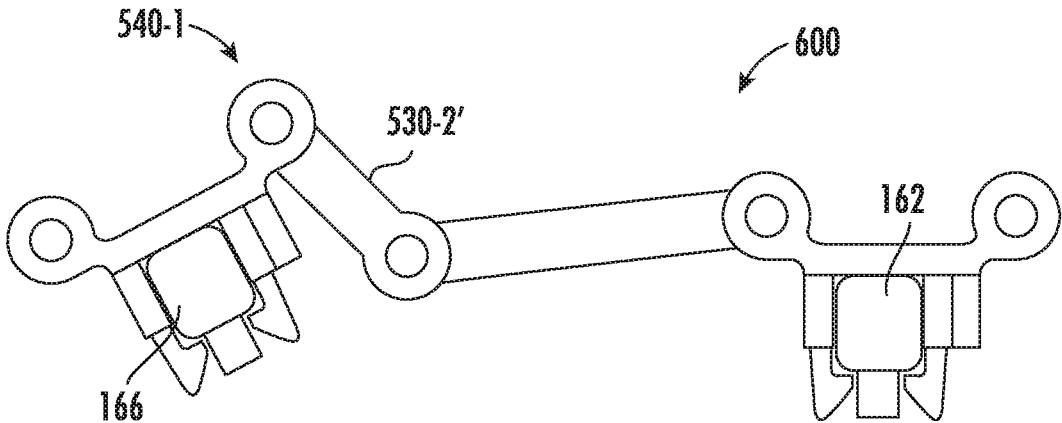

FIG. 10B

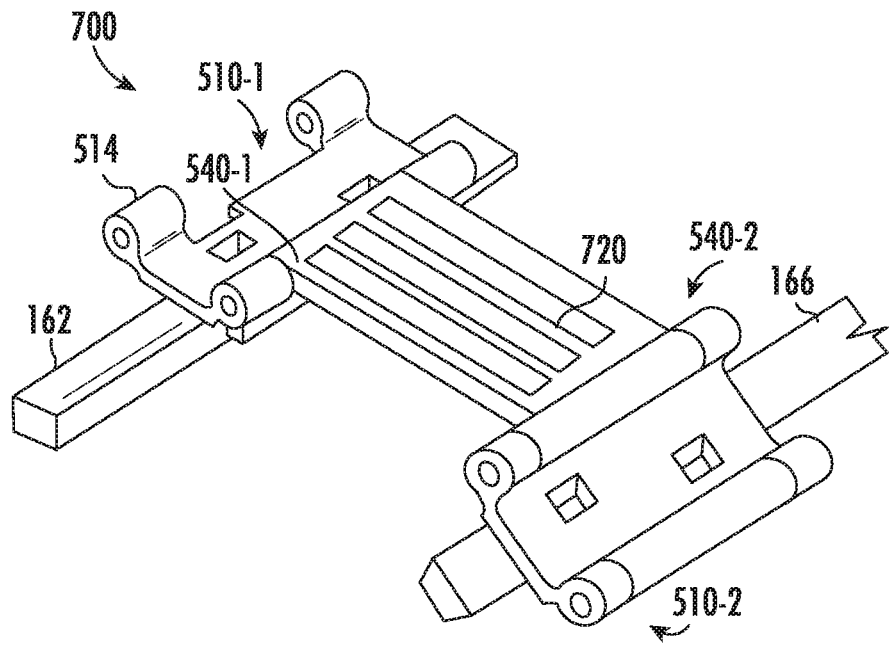
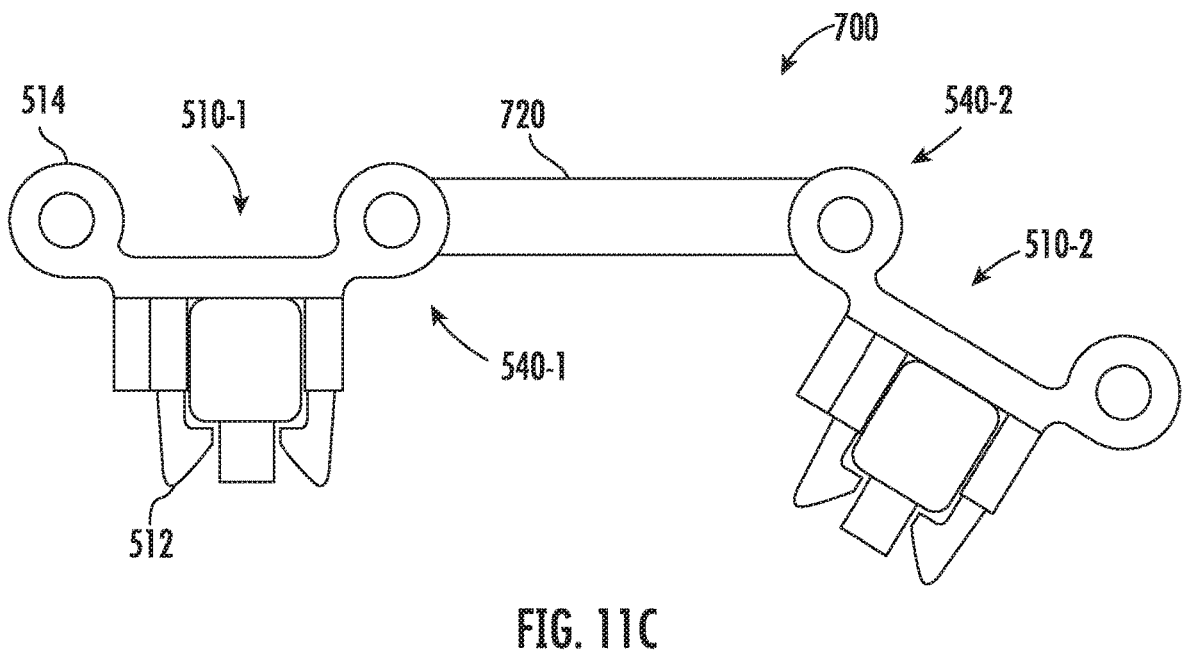
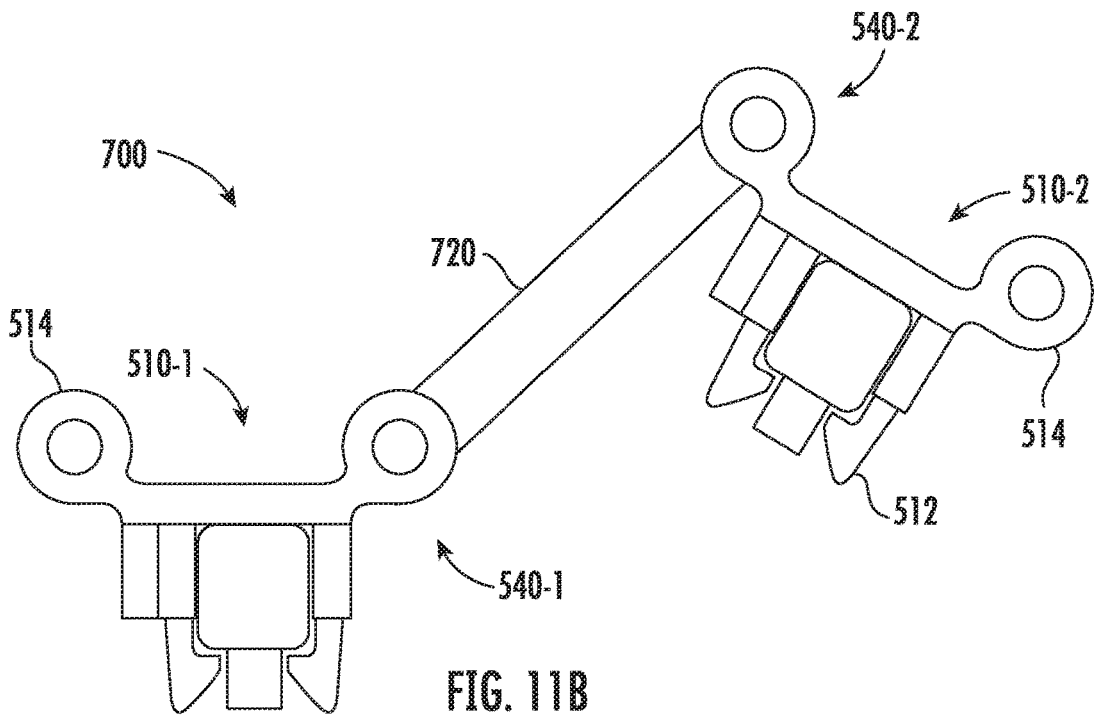

FIG. 11A



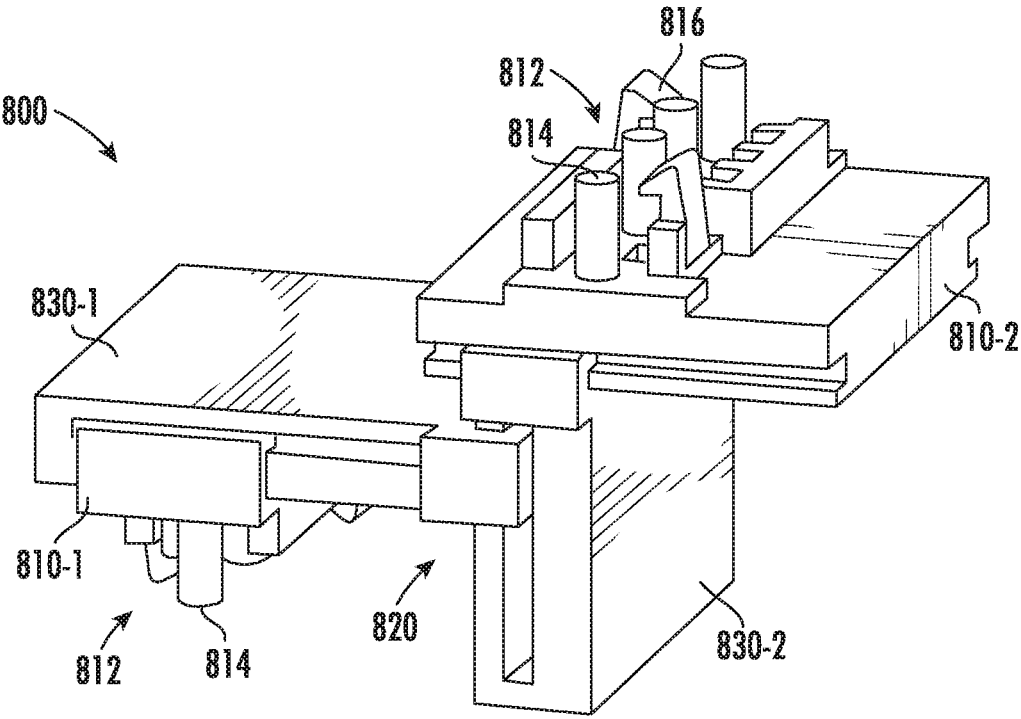

FIG. 12A

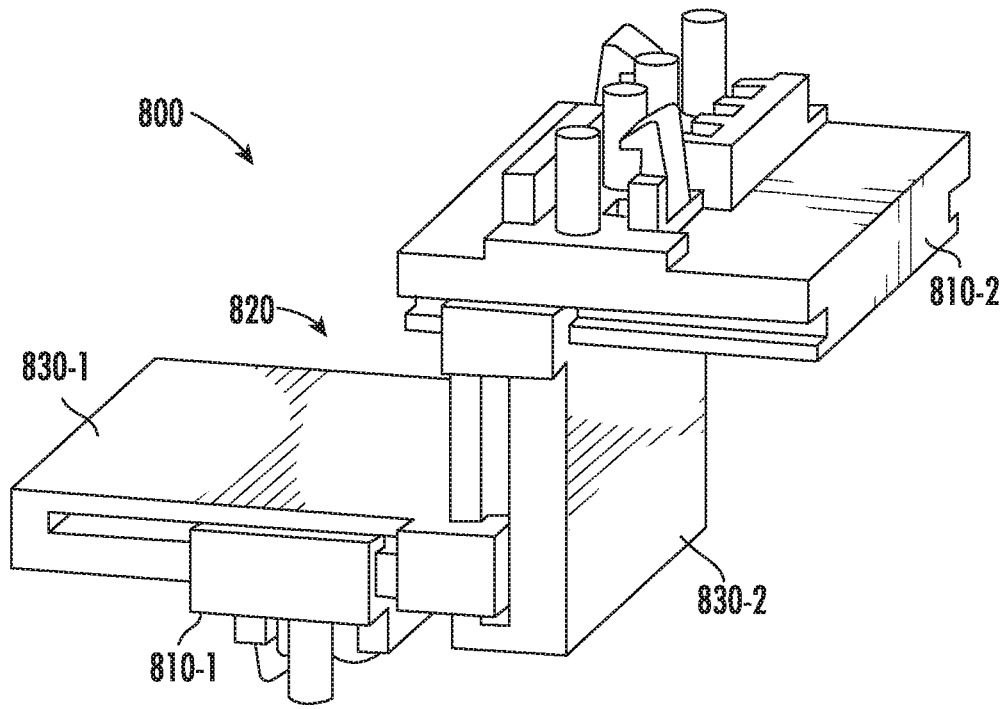

FIG. 12B

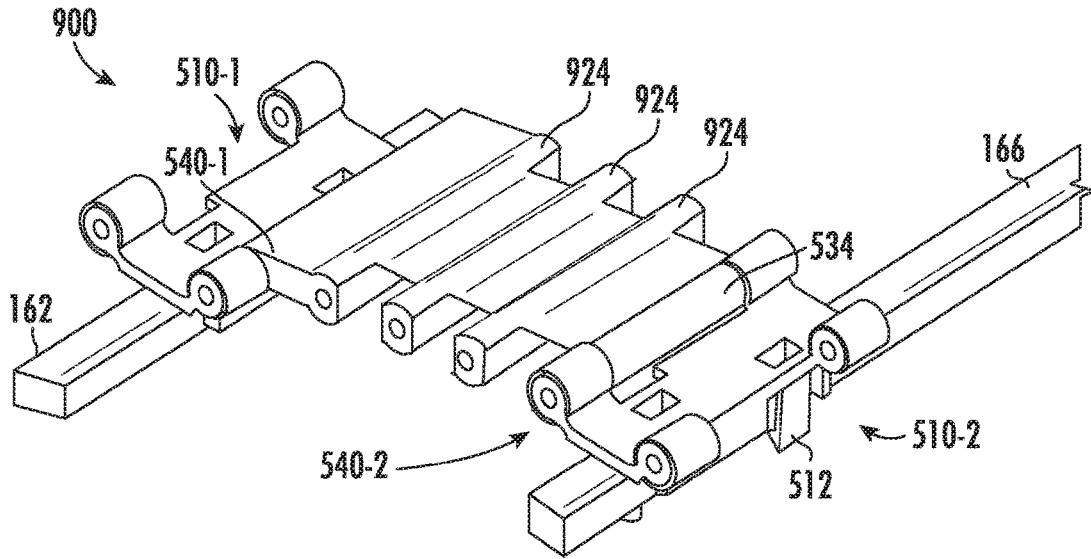

FIG. 13A

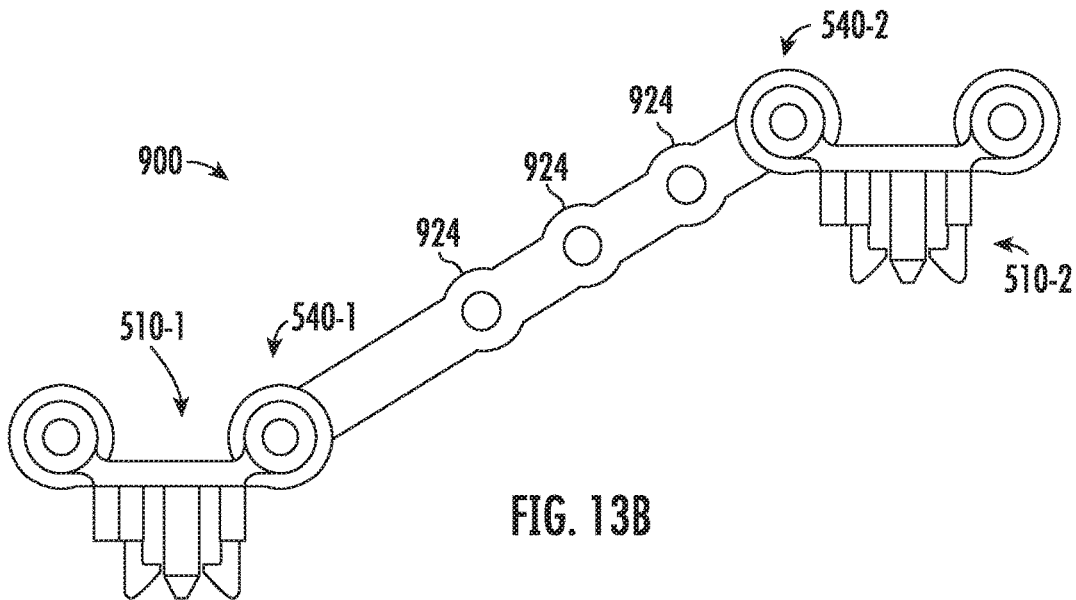
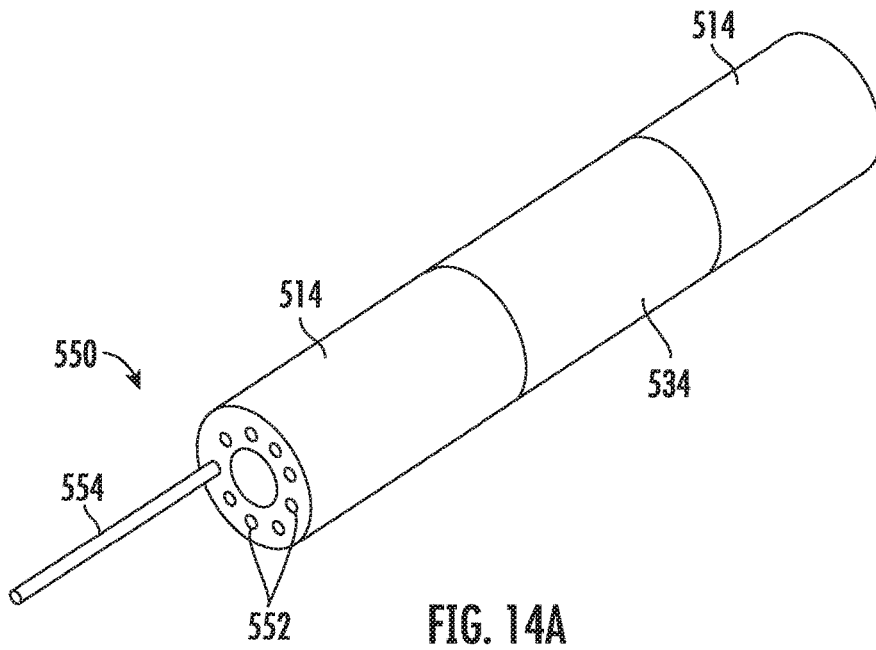
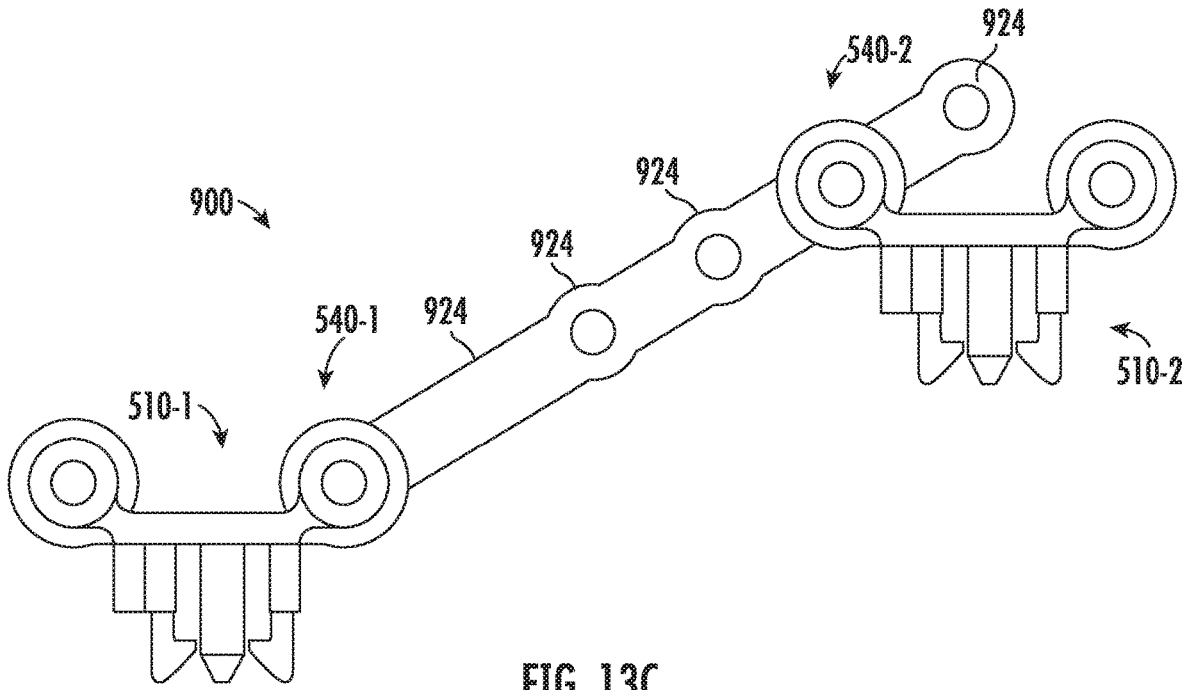
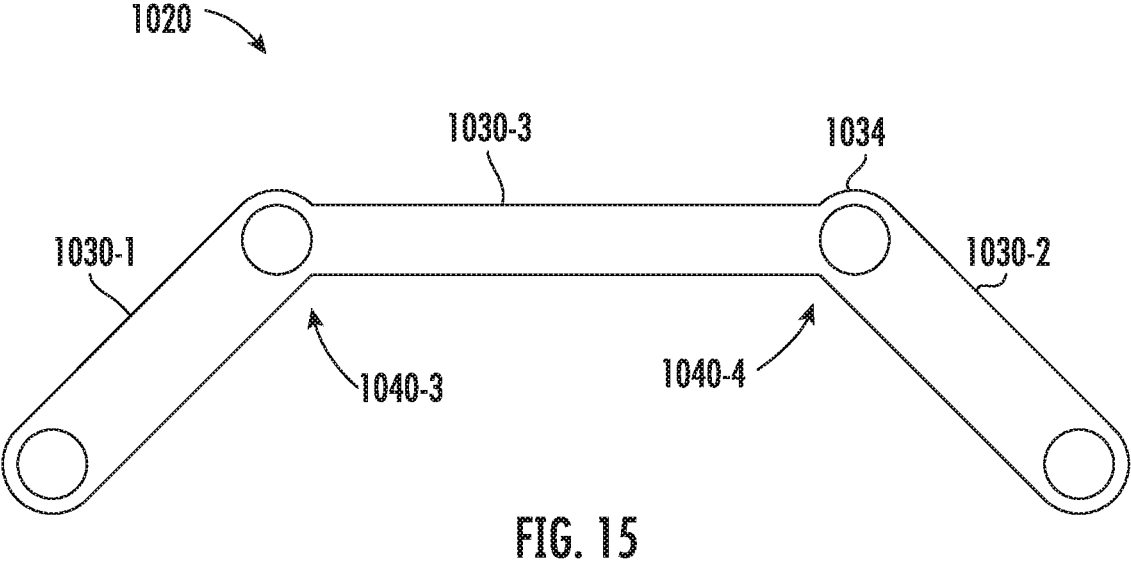
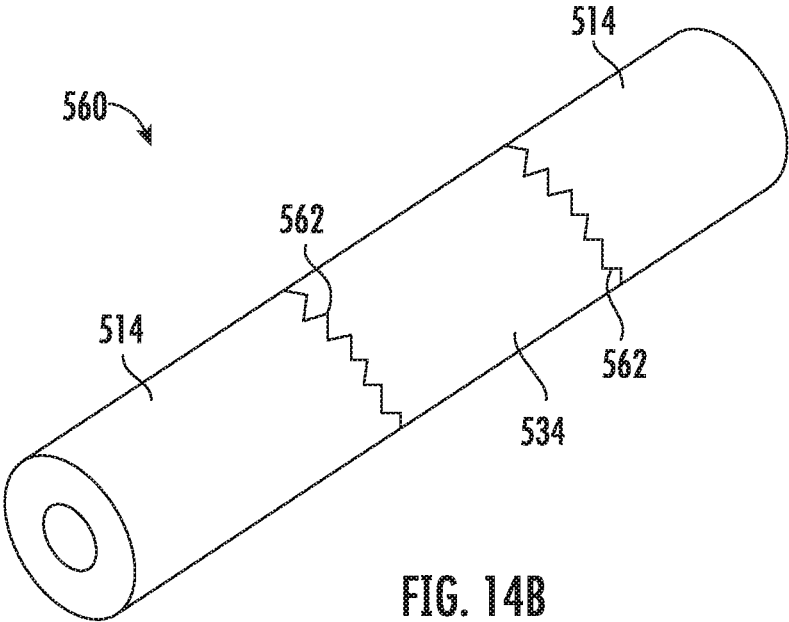

FIG. 13B





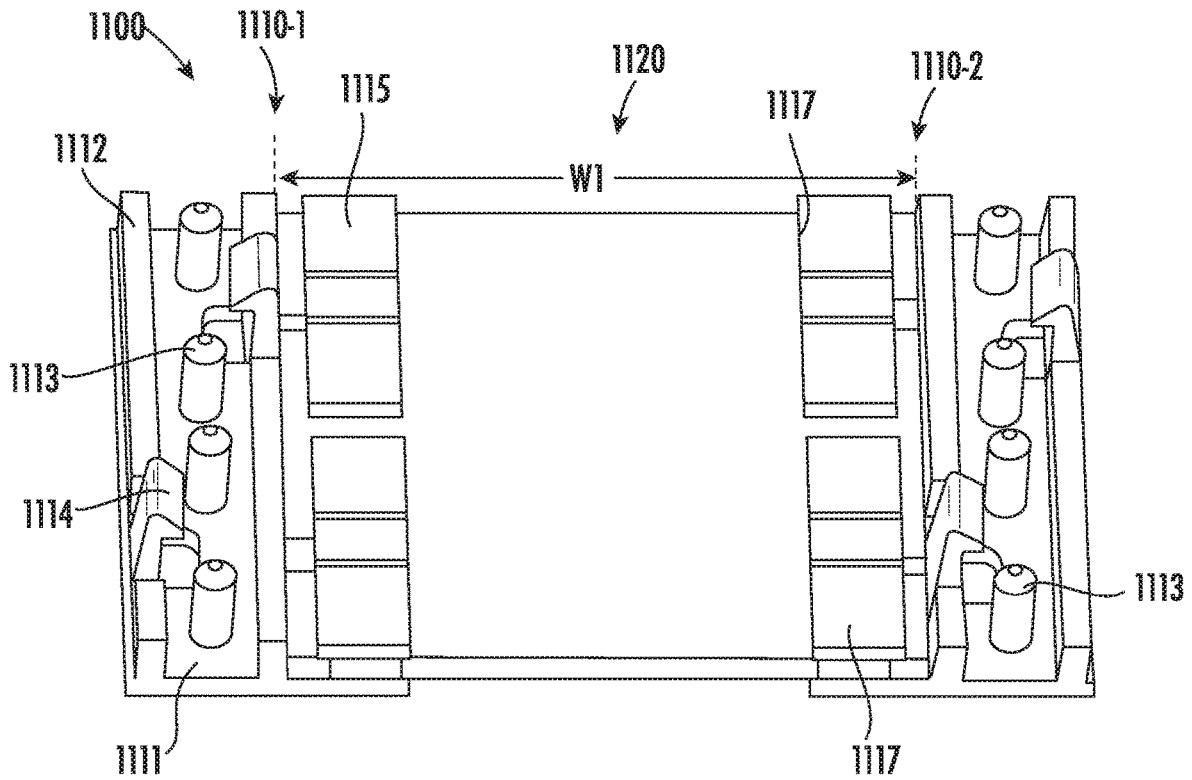

FIG. 16A

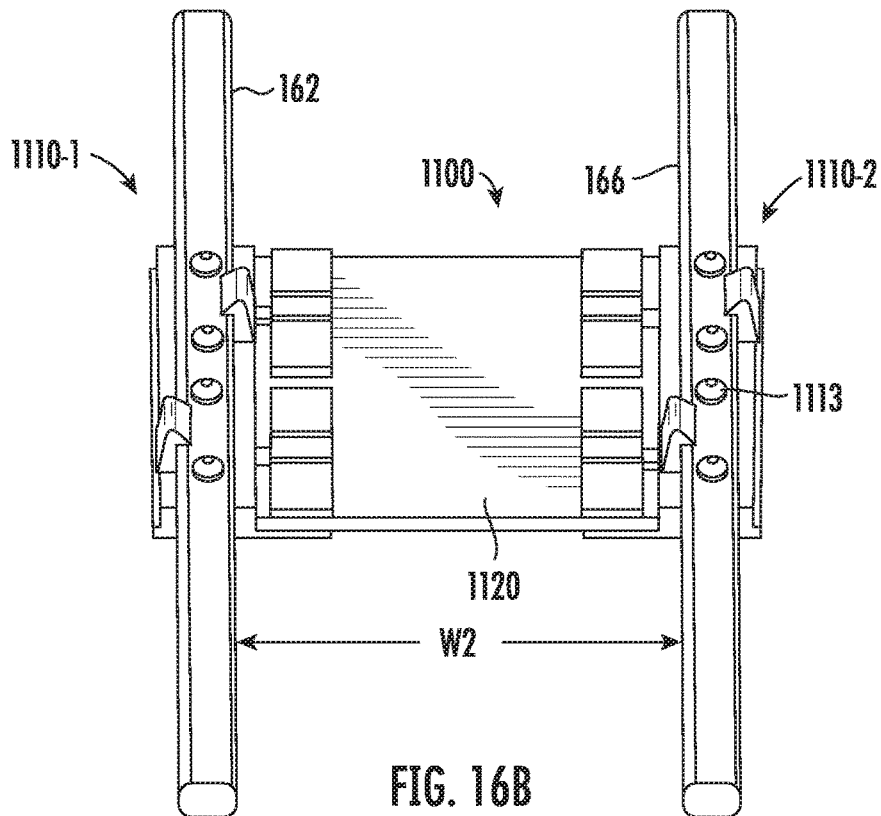

FIG. 16B

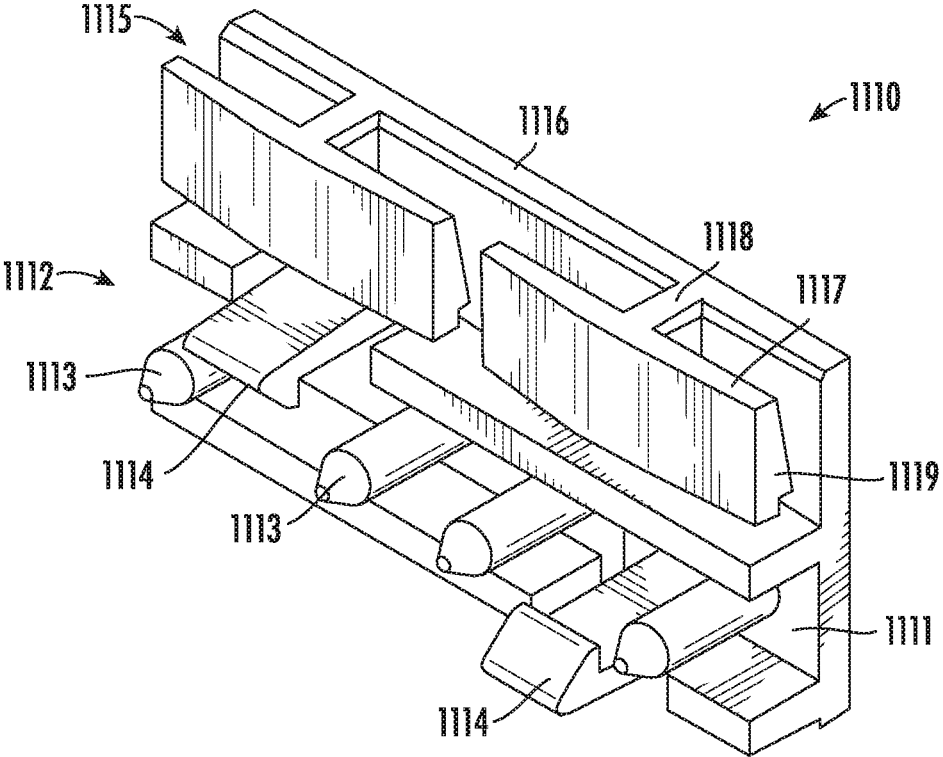

FIG. 17A

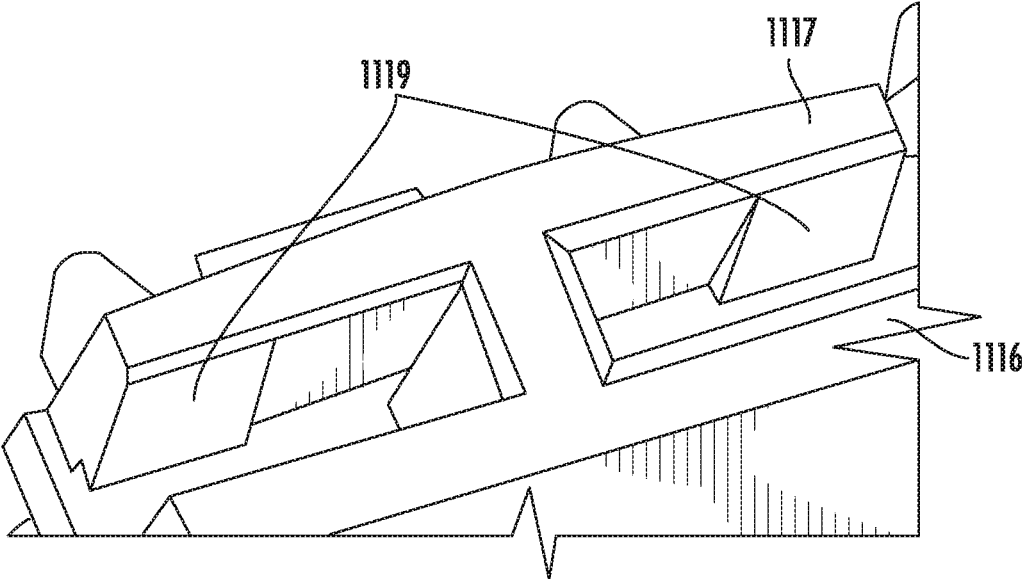

FIG. 17B

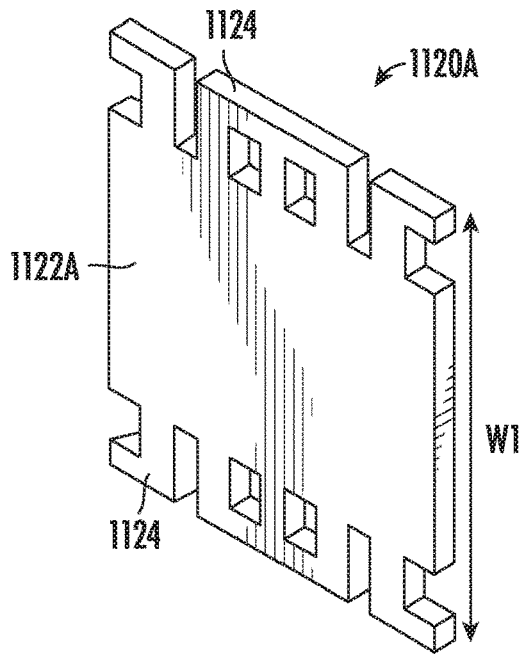

FIG. 18A

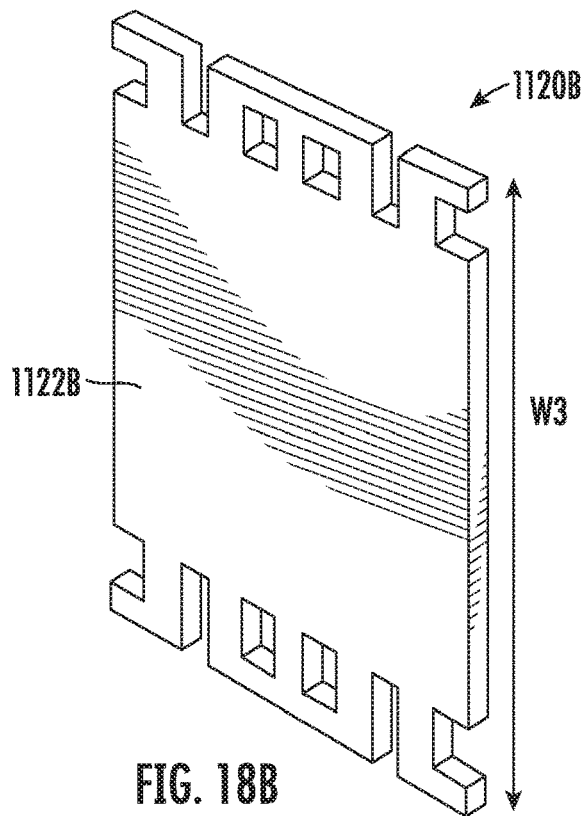

FIG. 18B

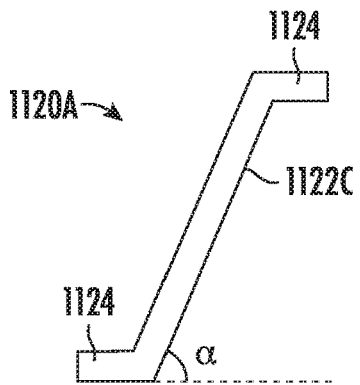

FIG. 18C

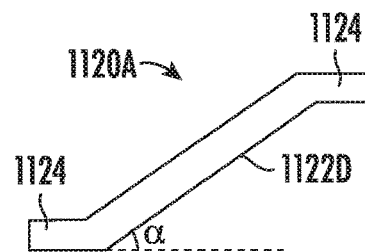

FIG. 18D

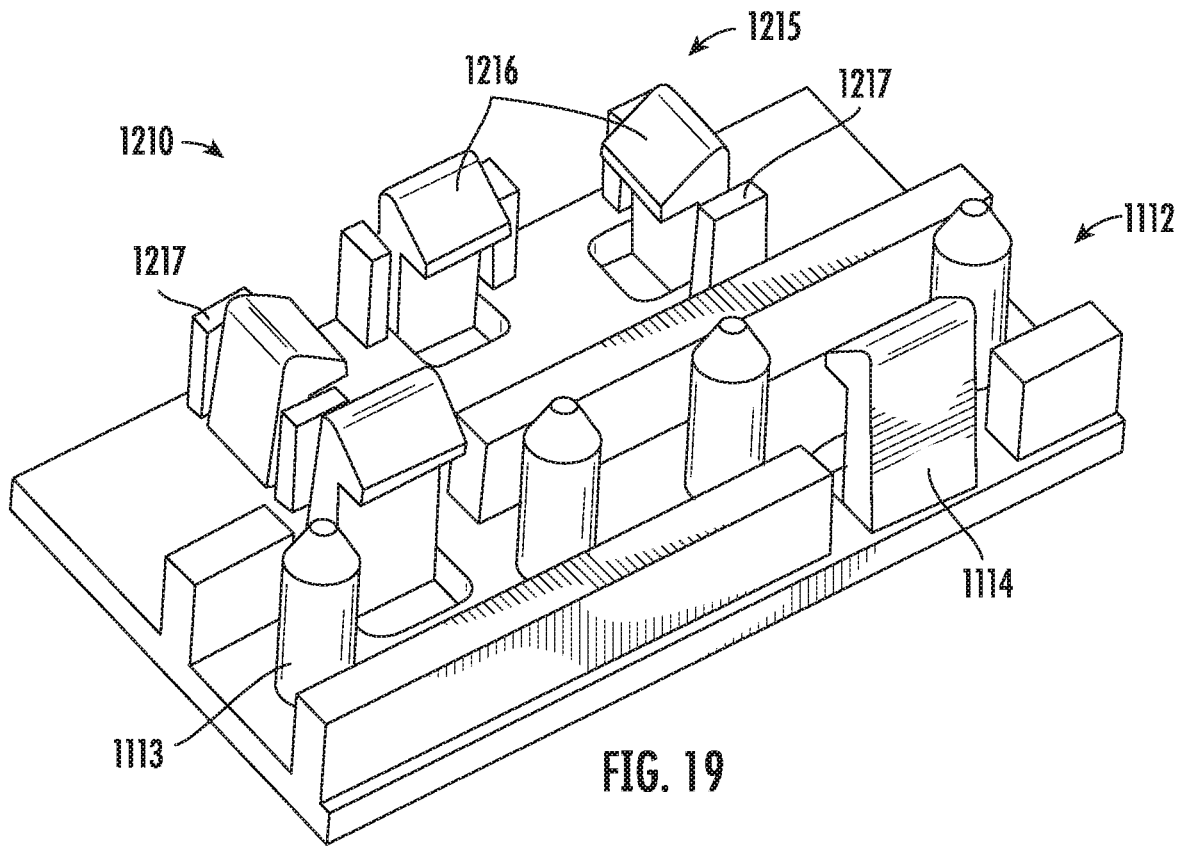

FIG. 19

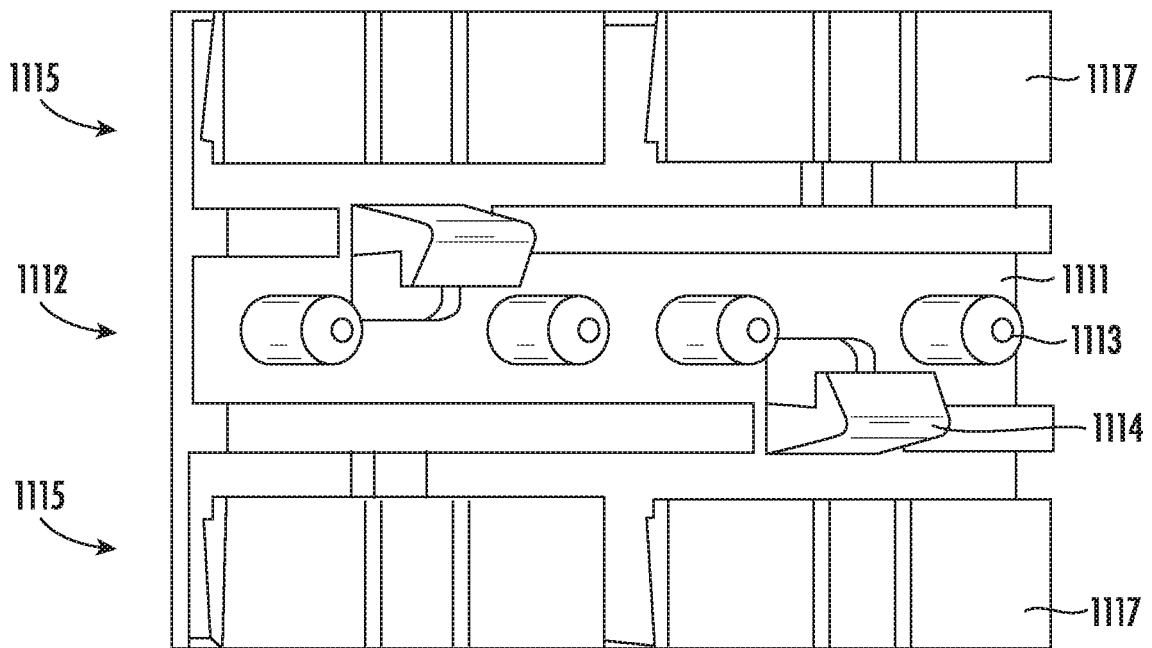

FIG. 20

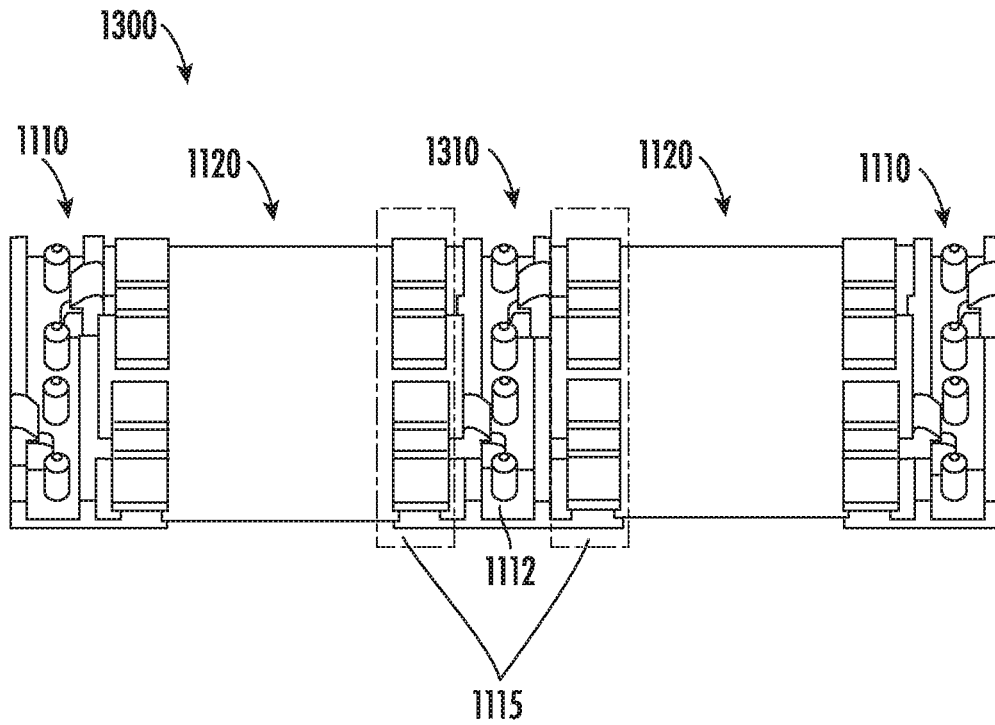

FIG. 21A

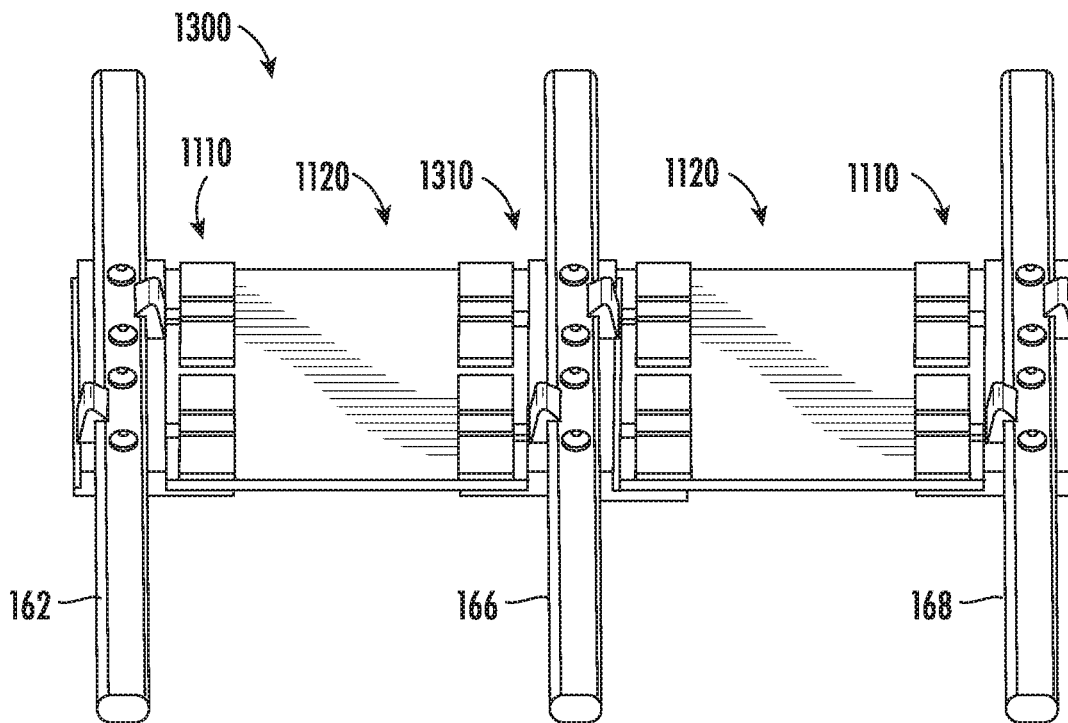

FIG. 21B

**REMOTE ELECTRONIC TILT BASE
STATION ANTENNAS HAVING ADJUSTABLE
RET LINKAGES**

CROSS-REFERENCE TO RELATED
APPLICATION

[0001] The present application claims priority under 35 U.S.C. § 119 to U.S. Provisional Application Ser. No. 62/696,996, filed Jul. 12, 2018, the entire content of which is incorporated herein by reference as if set forth fully herein.

FIELD OF THE INVENTION

[0002] The present invention relates to communication systems and, in particular, to base station antennas having remote electronic tilt capabilities.

BACKGROUND

[0003] Cellular communications systems are used to provide wireless communications to fixed and mobile subscribers. A cellular communications system may include a plurality of base stations that each provide wireless cellular service for a specified coverage area that is typically referred to as a “cell.” Each base station may include one or more base station antennas that are used to transmit radio frequency (“RF”) signals to, and receive RF signals from, the subscribers that are within the cell served by the base station.

[0004] Base station antennas are directional devices that can concentrate the RF energy that is transmitted in or received from certain directions. The “gain” of a base station antenna in a given direction is a measure of the ability of the antenna to concentrate the RF energy in that direction. The “radiation pattern” of a base station antenna—which is also referred to as an “antenna beam”—is a compilation of the gain of the antenna across all different directions. Each antenna beam may be designed to service a pre-defined coverage area such as the cell or a portion thereof that is referred to as a “sector.” Each antenna beam may be designed to have minimum gain levels throughout the pre-defined coverage area, and to have much lower gain levels outside of the coverage area to reduce interference between neighboring cells/sectors. Base station antennas typically comprise a linear array of radiating elements such as patch, dipole or crossed dipole radiating elements. Many base station antennas now include multiple linear arrays of radiating elements, each of which generates its own antenna beam.

[0005] Early base station antennas generated antenna beams having fixed shapes, meaning that once a base station antenna was installed, its antenna beam(s) could not be changed unless a technician physically reconfigured the antenna. Many modern base station antennas now have antenna beams that can be electronically reconfigured from a remote location. The most common way in which an antenna beam may be reconfigured electronically is to change the pointing direction of the antenna beam (i.e., the direction in which the antenna beam has the highest gain), which is referred to as electronically “steering” the antenna beam. An antenna beam may be steered horizontally in the azimuth plane and/or vertically in the elevation plane. An antenna beam can be electronically steered by transmitting control signals to the antenna that cause the antenna to alter the phases of the sub-components of the RF signals that are

transmitted and received by the individual radiating elements of the linear array that generates the antenna beam. Most modern base station antennas are configured so that the elevation or “tilt” angle of the antenna beams generated by the antenna can be electronically altered. Such antennas are commonly referred to as remote electronic tilt (“RET”) antennas.

[0006] In order to electronically change the down tilt angle of an antenna beam generated by a linear array of radiating elements, a phase taper may be applied across the radiating elements of the array. Such a phase taper may be applied by adjusting the settings on a phase shifter that is positioned along the RF transmission path between a radio and the individual radiating elements of the linear array. One widely-used type of phase shifter is an electromechanical “wiper” phase shifter that includes a main printed circuit board and a “wiper” printed circuit board that may be rotated above the main printed circuit board. Such wiper phase shifters typically divide an input RF signal that is received at the main printed circuit board into a plurality of sub-components, and then couple at least some of these sub-components to the wiper printed circuit board. The sub-components of the RF signal may be coupled from the wiper printed circuit board back to the main printed circuit board along a plurality of arc-shaped traces, where each arc has a different diameter. Each end of each arc-shaped trace may be connected to a respective sub-group of radiating elements that includes at least one radiating element. By physically (mechanically) rotating the wiper printed circuit board above the main printed circuit board, the locations where the sub-components of the RF signal couple back to the main printed circuit board may be changed, which thus changes the lengths of the transmission paths from the phase shifter to the respective sub-groups of radiating elements. The changes in these path lengths result in changes in the phases of the respective sub-components of the RF signal, and since the arcs have different radii, the phase changes along the different paths will be different. Typically, the phase taper is applied by applying positive phase shifts of various magnitudes (e.g., $+X^\circ$, $+2X^\circ$ and $+3X^\circ$) to some of the sub-components of the RF signal and by applying negative phase shifts of the same magnitudes (e.g., $-X^\circ$, $-2X^\circ$ and $-3X^\circ$) to additional of the sub-components of the RF signal. Exemplary phase shifters of this variety are discussed in U.S. Pat. No. 7,907,096 to Timofeev, the disclosure of which is hereby incorporated herein in its entirety. The wiper printed circuit board is typically moved using an electromechanical actuator such as a DC motor that is connected to the wiper printed circuit board via a mechanical linkage. These actuators are often referred to as “RET actuators.” Both individual RET actuators that drive a single mechanical linkage and “multi-RET actuators” that have a plurality of output members that drive a plurality or respective mechanical linkages are commonly used in base station antennas.

SUMMARY

[0007] Pursuant to embodiments of the present invention, base station antennas are provided that include a RET actuator, a phase shifter having a moveable element, and a mechanical linkage extending between the RET actuator and the phase shifter. The mechanical linkage includes an adjustable RET linkage that has a first link that has a first connection element, a second link that has a second connection element and a connecting member that includes at

least a third link. The adjustable RET linkage includes at least a first hinge and a second hinge.

[0008] In some embodiments, the first hinge may connect the first link to the connecting member and/or the second hinge may connect the second link to the connecting member.

[0009] In some embodiments, the connection member may include the third link and a fourth link that is connected to the third link via a third hinge. In such embodiments, the first hinge may connect the first link to the third link and the second hinge may connect the second link to the fourth link. In some embodiments, the third link and the fourth link may have different sizes.

[0010] In some embodiments, the first connection element may be attached to a first RET rod of the mechanical linkage and the second connection element may be attached to a second RET rod of the mechanical linkage.

[0011] Pursuant to further embodiments of the present invention, base station antennas are provided that include a RET actuator, a phase shifter having a moveable element, and a mechanical linkage extending between the RET actuator and the phase shifter. The mechanical linkage includes a first RET rod, a second RET rod and an adjustable RET linkage that connects the first RET rod to the second RET rod. The adjustable RET linkage includes a first connection element that connects to the first RET rod and a second connection element that connects to the second RET rod. The adjustable RET linkage is configured so that a distance between the first connection element and the second connection element is adjustable.

[0012] In some embodiments, the adjustable RET linkage may include at least one hinge.

[0013] In some embodiments, the adjustable RET linkage may include a locking element.

[0014] In some embodiments, the adjustable RET linkage may be a multi-piece adjustable RET linkage that includes a first link and a second link that are configured to slide relative to one another.

[0015] In some embodiments, the adjustable RET linkage may be configured so that the distance between the first connection element and the second connection element is adjustable by at least 10 millimeters.

[0016] In some embodiments, the adjustable RET linkage may be a multi-piece adjustable RET linkage that includes a first link that is configured to attach to the first RET rod and a second link that is configured to attach to the second RET rod. In such embodiments, the adjustable RET linkage may include at least one additional link that is coupled between the first link and the second link. The first link may include a first annular receptacle and a second annular receptacle that is not collinear with the first annular receptacle.

[0017] In some embodiments, the adjustable RET linkage may include at least two hinges.

[0018] In some embodiments, the first connection element may be rotatable with respect to the second connection element.

[0019] In some embodiments, the adjustable RET linkage may be a multi-piece adjustable RET linkage that includes a first link and a second link that is configured to move relative to the first link.

[0020] In some embodiments, the adjustable RET linkage may be a multi-piece adjustable RET linkage that includes a first link that includes the first connection element, a second link that includes the second connection element,

and third and fourth links that are connected between the first and second links. The third link and the fourth link may have different lengths in some embodiments.

[0021] In some embodiments, the first link may be connected to the third link by a first hinge, the third link may be connected to the fourth link by a second hinge, and the fourth link may be connected to the second link by a third hinge.

[0022] In some embodiments, the mechanical linkage may be configured to move the moveable element of the phase shifter in response to movement of the RET actuator.

[0023] In some embodiments, the adjustable RET linkage may comprise a multi-part RET linkage that includes a first piece that is mounted on the first RET rod, a second piece that is mounted on the second RET rod, and a third piece that connects the first piece to the second piece, wherein dimensions of the third piece are selected based at least in part on a distance between the first RET rod and the second RET rod in at least one of a width direction and a depth direction of the base station antenna. In some embodiments, the first and second pieces are plastic pieces and the third piece is a metal piece. For example, the third piece may be formed of stamped sheet metal. In some embodiments, the third piece may have mating features on opposed ends thereof that are configured to mate with corresponding mating features on the respective first and second pieces. In some embodiments, the third piece may be connected to the first piece by a snap-fit or snap-in connection.

[0024] Pursuant to further embodiments of the present invention, base station antennas are provided that include a RET actuator, a phase shifter having a moveable element, and a mechanical linkage extending between the RET actuator and the phase shifter. The mechanical linkage includes a first RET rod and an adjustable RET linkage that connects to the first RET rod, the adjustable RET linkage including a first link and a second link that is configured to move relative to the first link.

[0025] In some embodiments, the adjustable RET linkage may include at least one hinge.

[0026] In some embodiments, the adjustable RET linkage may include a locking element.

[0027] In some embodiments, the first link and the second link may be configured to slide relative to one another.

[0028] In some embodiments, the adjustable RET linkage may include a first connection element that connects to the first RET rod and a second connection element, and a distance between the first connection element and the second connection element may be adjustable.

[0029] In some embodiments, the first connection element may be rotatable with respect to the second connection element.

[0030] In some embodiments, the adjustable RET linkage may include at least one additional link that is coupled between the first link and the second link.

[0031] In some embodiments, the adjustable RET linkage may include at least two hinges.

[0032] In some embodiments, the adjustable RET linkage may further include a third link and a fourth link that are connected between the first and second links.

[0033] In some embodiments, the third link and the fourth link may have different lengths.

[0034] In some embodiments, the first link may be connected to the third link by a first hinge, the third link may be

connected to the fourth link by a second hinge, and the fourth link may be connected to the second link by a third hinge.

[0035] In some embodiments, the mechanical linkage may be configured to move the moveable element of the phase shifter in response to movement of the RET actuator.

[0036] Pursuant to further embodiments of the present invention, base station antennas are provided that include a RET actuator, a phase shifter having a moveable element, and a mechanical linkage extending between the RET actuator and the phase shifter. The mechanical linkage includes a first RET rod, a second RET rod and an adjustable RET linkage that connects the first RET rod to the second RET rod. The adjustable RET linkage includes a first connection element that connects to the first RET rod and a second connection element that connects to the second RET rod. The first connection element is rotatable with respect to the second connection element.

[0037] In some embodiments, the adjustable RET linkage may include at least one hinge.

[0038] In some embodiments, the adjustable RET linkage may further include a locking element.

[0039] In some embodiments, the adjustable RET linkage may comprise a multi-piece adjustable RET linkage that includes a first link and a second link that are configured to slide relative to one another.

[0040] In some embodiments, the adjustable RET linkage may include at least three links and at least two hinges.

[0041] Pursuant to further embodiments of the present invention, base station antennas are provided that include a RET actuator, a phase shifter having a moveable element, and a mechanical linkage extending between the RET actuator and the phase shifter. The mechanical linkage includes a first RET rod, a second RET rod and a multi-piece RET linkage that includes a first piece that is mounted on the first RET rod, a second piece that is mounted on the second RET rod, and a third piece that is directly connected to the first piece. The dimensions of the third piece are selected based at least in part on a distance between the first RET rod and the second RET rod in at least one of a width direction and a depth direction of the base station antenna.

[0042] In some embodiments, the third piece may also be directly connected to the second piece, while in other embodiments the third piece may be indirectly connected to the second piece. In some embodiments, the first and second pieces may be plastic pieces and the third piece may be a sheet metal piece. In some embodiments, the third piece may have mating features on opposed ends thereof that are configured to mate with corresponding mating features on the respective first and second pieces via, for example, snap-fit or snap-in connect.

BRIEF DESCRIPTION OF THE DRAWINGS

[0043] FIG. 1A is a perspective view of an example base station antenna according to embodiments of the present invention.

[0044] FIG. 1B is a perspective view of the base station antenna of FIG. 1A with the radome thereof removed.

[0045] FIG. 2 is a schematic block diagram illustrating the electrical connections between various of the components of the base station antenna of FIGS. 1A-1B.

[0046] FIG. 3 is a front perspective view of a pair of electromechanical phase shifters that may be included in the base station antenna of FIGS. 1A-1B.

[0047] FIG. 4 is perspective view of a multi-RET actuator that may be included in the base station antenna of FIGS. 1A-1B.

[0048] FIG. 5 is a rear view of a portion of the base station antenna of FIGS. 1A-1B that shows how mechanical linkages are used to connect the output members of the multi-RET actuator of FIG. 4 to respective ones of the phase shifters illustrated in FIGS. 2 and 3.

[0049] FIGS. 6A-6G are perspective views of examples of conventional RET linkages.

[0050] FIG. 7 is a perspective view of an adjustable RET linkage according to embodiments of the present invention.

[0051] FIGS. 8A-8D are side views illustrating how the adjustable RET linkage of FIG. 7 may be configured to connect to elements of a mechanical linkage that are spaced apart from each other by different distances.

[0052] FIGS. 9A and 9B are a perspective view and a side view, respectively, of an adjustable RET linkage according to further embodiments of the present invention that includes connecting members that have links of different lengths.

[0053] FIGS. 10A and 10B are side views illustrating how the adjustable RET linkages according to embodiments of the present invention may be configured to connect to elements of a mechanical linkage at different angles.

[0054] FIG. 11A is a perspective view illustrating an adjustable RET linkage according to further embodiments of the present invention that includes a single-piece connecting member.

[0055] FIGS. 11B and 11C are side views of the adjustable RET linkage of FIG. 11A.

[0056] FIGS. 12A and 12B are perspective views of an adjustable RET linkage according to further embodiments of the present invention that includes links that slide relative to one another.

[0057] FIG. 13A is a perspective view of an adjustable RET linkage according to still further embodiments of the present invention.

[0058] FIGS. 13B and 13C are side views of the adjustable RET linkage of FIG. 13A.

[0059] FIGS. 14A and 14B are schematic perspective views illustrating two example locking mechanisms that may be included on the adjustable RET linkages according to embodiments of the present invention.

[0060] FIG. 15 is a schematic side view of a connecting member that may be used in adjustable RET linkages according to further embodiments of the present invention.

[0061] FIG. 16A is a perspective view of an adjustable RET linkage according to yet additional embodiments of the present invention.

[0062] FIG. 16B is a perspective view illustrating how the adjustable RET linkage of FIG. 16A may be used to connect two RET rods.

[0063] FIG. 17A is a perspective view of a standardized part of the adjustable RET linkage of FIG. 16.

[0064] FIG. 17B is an enlarged perspective view of an end portion of the standardized part of FIG. 17A.

[0065] FIGS. 18A and 18B are perspective views of two example changeable parts that may be used to form the adjustable RET linkage of FIG. 16.

[0066] FIGS. 18C and 18D are side views of two additional example changeable parts that may be used to form the adjustable RET linkage of FIG. 16.

[0067] FIG. 19 is a perspective view of an alternative standardized part for the adjustable RET linkage of FIG. 16.

[0068] FIG. 20 is a perspective view of a standardized part of an adjustable RET linkage according to embodiments of the present invention that may be used to connect more than two RET rods together.

[0069] FIG. 21A is a perspective view of an adjustable RET linkage according to embodiments of the present invention that includes the standardized part of FIG. 20.

[0070] FIG. 21B is a perspective view illustrating how the adjustable RET linkage of FIG. 21A may be used to connect two RET rods

DETAILED DESCRIPTION

[0071] Modern base station antennas often include two, three or more linear arrays of radiating elements, where each linear array has an electronically adjustable down tilt. The linear arrays typically include cross-polarized radiating elements, and a separate phase shifter is provided for electronically adjusting the down tilt of the antenna beam for each polarization, so that the antenna may include twice as many phase shifters as linear arrays. Moreover, in many antennas, separate transmit and receive phase shifters are provided so that the transmit and receive radiation patterns may be independently adjusted. This again doubles the number of phase shifters. Thus, it is not uncommon for a base station antenna to have eight, twelve or more phase shifters for applying remote electronic down tilts to the linear arrays. As described above, RET actuators are provided in the antenna that are used to adjust the phase shifters. While the same downtilt is typically applied to the phase shifters for the two different polarizations, allowing a single RET actuator and a single mechanical linkage to be used to adjust the phase shifters for both polarizations, modern base station antennas still often include four, six or more RET actuators (or, alternatively, one or two multi-RET actuators) and associated mechanical linkages.

[0072] In order to change the downtilt angle of an antenna beam generated by a linear array on a base station antenna, a control signal may be transmitted to the antenna that causes a RET actuator associated with the linear array to generate a desired amount of movement in an output member thereof. The movement may comprise, for example, linear movement or rotational movement. A mechanical linkage is used to translate the movement of the output member of the RET actuator to movement of a moveable element of a phase shifter (e.g., a wiper arm) associated with the linear array. Accordingly, each mechanical linkage may extend between the output member of the RET actuator and the moveable element of the phase shifter.

[0073] Typically, a mechanical linkage may comprise a series of longitudinally-extending plastic or fiberglass RET rods that are connected by RET linkages that extend in the width and/or depth directions of the antenna. The RET linkages connect the RET rods to each other and/or to the RET actuator or the phase shifter. Multiple RET rods are often used because the output member of a RET actuator is often not aligned with the input member of an associated phase shifter in either or both the width or depth directions. Thus, for example, a RET linkage may be used to connect a first RET rod that is attached to the output member of a RET actuator to a second RET rod that is attached to the input member of a phase shifter in situations where the first and second RET rods are not aligned in either or both the

width and depth directions. RET linkages may also or alternatively be used to connect a RET rod to the output member of a RET actuator and/or to an input member of a phase shifter. RET linkages can also be used to route a mechanical linkage around other components of the base station antenna that may be interposed along a direct path between the output member of the RET actuator and the input member of the associated phase shifter. The RET linkages may thus be used to form “jogs” in the mechanical linkage for either or both alignment and/or routing purposes. In many cases, three or even four RET rods may be included within a single mechanical linkage, thereby requiring multiple RET linkages for a single mechanical linkage. Moreover, the size and shape required for each RET linkage tends to vary. As such, a single base station antenna will typically require at least three or four (and often many more) different RET linkage designs, thereby increasing the parts count for the antenna.

[0074] Pursuant to embodiments of the present invention, base station antennas are provided that include mechanical linkages having adjustable RET linkages that can dramatically reduce the number of RET linkages that a particular base station antenna manufacturer need maintain in inventory. The adjustable RET linkages according to embodiments of the present invention may include a first link that is configured to connect to a first RET rod and a second link that is configured to connect to a second RET rod. The adjustable RET linkages may further include a connecting member that connects the first link to the second link. The connecting member may include one or more additional links.

[0075] In some embodiments, the adjustable RET linkages may include a first hinged connection between the first link and the connecting member and/or a second hinged connection between the second link and the connecting member. In addition, in some cases, the connecting member may include one or more hinged connections between distinct links thereof. These hinged connections may allow the adjustable RET linkage to span a range of different distances in the width and depth directions so that the same mechanical linkage may be used to connect elements that are spaced apart from each other by different distances or which are arranged with respect to each other at different orientations. As a result, a small number of different adjustable RET linkages may be used to connect RET rods that are spaced apart from each other at different distances and/or at different orientations. This may allow antenna manufacturers to hold fewer parts in inventory and may avoid the need to design and fabricate new RET linkages each time a new antenna is designed.

[0076] In other embodiments of the present invention, the adjustable RET linkage may include one or more sliding connections. In these embodiments, the first link may be connected to either the second link or to a connecting member by a sliding connection. The second link may also be connected to the connecting member by a sliding connection. Alternatively or additionally, the connecting member may include a sliding connection between two links thereof that allow a length of the connecting member (e.g., in the width direction) to be varied. The sliding connections may be set using locking mechanisms so that the adjustable RET linkage spans desired distances in the width and depth directions.

[0077] In additional embodiments, adjustable RET linkages are provided that include a first link that is configured to connect to a first RET rod, a second link that is configured to connect to a second RET rod, and a connecting member that has multiple attachment points for attaching to the first and/or second links. The first link may be connected to the connecting member by a first hinged connection and the second link may be connected to the connecting member by a second hinged connection. By selecting different of the attachment points, the length of the connecting member may be adjusted.

[0078] It will also be appreciated that the above embodiments may be combined in any manner. For example, an adjustable RET linkage may be provided that has any or all of a hinged connection, a sliding connection and a connecting member with multiple attachment points.

[0079] The adjustable RET linkages according to embodiments of the present invention may greatly reduce the number of RET linkages that a base station antenna manufacturer need design and develop. In addition, since the adjustable RET linkages may connect two RET rods that are spaced apart by a range of distances, the need to design new RET linkages to accommodate different RET rod configurations in new antenna designs may be greatly reduced.

[0080] Pursuant to further embodiments of the present invention, adjustable RET linkages are provided that are formed using two standardized parts and a selected one of a plurality of changeable parts. The standardized parts may comprise, for example, injection molded plastic parts that all have the same design that are each configured to be mounted on a RET rod of a base station antenna. The standardized parts may be used across a wide variety of different base station antenna designs, and hence may be manufactured in very high volumes. The changeable parts may be changeable connection members that extend between and connect two standardized parts so that the adjustable RET linkage will connect two RET rods together. A wide variety of different changeable connection members may be provided that are configured to span different distances in the width and depth directions of the antennas (and in the longitudinal direction as well in some cases), and the appropriate changeable connection member for any given adjustable RET linkage may be selected based at least in part on the distance between the RET rods that are to be joined in the width and depth directions. The changeable connection members may, for example, be metal parts that are stamped and/or bent from sheet metal and that have connection features at their opposed ends that allow each changeable connection member to be connected to two different standardized parts.

[0081] Embodiments of the present invention will now be discussed in greater detail with reference to the drawings. In some cases, two-part reference numerals are used in the drawings. Herein, elements having such two-part reference numerals may be referred to individually by their full reference numeral (e.g., linear array 120-2) and may be referred to collectively by the first part of their reference numerals (e.g., the linear arrays 120).

[0082] FIG. 1A is a perspective view of a RET base station antenna 100 according to embodiments of the present invention. FIG. 1B is a perspective view of the base station antenna 100 with the radome removed to show the four linear arrays of radiating elements that are included in antenna 100.

[0083] As shown in FIG. 1A, the RET antenna 100 includes a radome 102, a mounting bracket 104, and a bottom end cap 106. A plurality of input/output ports 110 are mounted in the end cap 106. Coaxial cables (not shown) may be connected between the input/output ports 110 and the RF ports on one or more radios (not shown). These coaxial cables may carry RF signals between the radios and the base station antenna 100. The input/output ports 110 may also include control ports that carry control signals to the base station antenna 100 from a controller that is located remotely from base station antenna 100. These control signals may include control signals for electronically changing the tilt angle of the antenna beams generated by the base station antenna 100.

[0084] For ease of reference, FIG. 1A includes a coordinate system that defines the length (L), width (W) and depth (D) axes (or directions) of the base station antenna 100 that will be discussed throughout the application. The length axis may also be referred to as the longitudinal axis.

[0085] FIG. 1B is a perspective view of the base station antenna of FIG. 1A with the radome 102 removed. As shown in FIG. 1B, the base station antenna 100 includes two linear arrays 120-1, 120-2 of low-band radiating elements 122 (i.e., radiating elements that transmit and receive signals in a lower frequency band) and two linear arrays 130-1, 130-2 of high-band radiating elements 132 (i.e., radiating elements that transmit and receive signals in a higher frequency band). Each of the low-band radiating elements 122 is implemented as a cross-polarized radiating element that includes a first dipole that is oriented at an angle of -45° with respect to the azimuth plane and a second dipole that is oriented at an angle of $+45^\circ$ with respect to the azimuth plane. Similarly, each of the high-band radiating elements 132 is implemented as a cross-polarized radiating element that includes a first dipole that is oriented at an angle of -45° with respect to the azimuth plane and a second dipole that is oriented at an angle of $+45^\circ$ with respect to the azimuth plane. Since cross-polarized radiating elements are provided, each linear array 120-1, 120-2, 130-1, 130-2 will generate two antenna beams, namely a first antenna beam generated by the -45° dipoles and a second antenna beam generated by the $+45^\circ$ dipoles. The radiating elements 122, 132 extend forwardly from a backplane 112 with may comprise, for example, a sheet of metal that serves as a ground plane for the radiating elements 122, 132.

[0086] FIG. 2 is a schematic block diagram illustrating various additional components of the RET antenna 100 and the electrical connections therebetween. It should be noted that FIG. 2 does not show the actual location of the various elements on the antenna 100, but instead is drawn to merely show the electrical transmission paths between the various elements.

[0087] As shown in FIG. 2, each input/output port 110 may be connected to a phase shifter 150. The base station antenna 100 performs duplexing between the transmit and receive sub-bands for each linear array 120, 130 within the antenna (which allows different downtilts to be applied to the transmit and receive sub-bands), and hence each linear array 120, 130 includes both a transmit (input) port 110 and a receive (output) port 110. A first end of each transmit port 110 may be connected to the transmit port of a radio (not shown) such as a remote radio head. The other end of each transmit port 110 is coupled to a transmit phase shifter 150. Likewise, a first end of each receive port 110 may be

connected to the receive port of a radio (not shown), and the other end of each receive port **110** is coupled to a receive phase shifter **150**. Two transmit ports, two receive ports, two transmit phase shifters and two receive phase shifters are provided for each linear array **120**, **130** to handle the two different polarizations.

[0088] Each transmit phase shifter **150** divides an RF signal input thereto into five sub-components, and applies a phase taper to these sub-components that sets the tilt (elevation) angle of the antenna beam generated by an associated linear array **120**, **130** of radiating elements **122**, **132**. The five outputs of each transmit phase shifter **150** are coupled to five respective duplexers **140** that pass the sub-components of the RF signal output by the transmit phase shifter **150** to five respective sub-arrays of radiating elements **122**, **132**. In the example antenna **100** shown in FIGS. 1A, 1B and 2, each low-band linear array **120** includes ten low-band radiating elements **122** that are grouped as five sub-arrays of two radiating elements **122** each. Each high-band linear array **130** includes fifteen high-band radiating elements **132** that are grouped as five sub-arrays of three radiating elements **132** each.

[0089] Each sub-array of radiating elements passes received RF signals to a respective one of the duplexers **140**, which in turn route those received RF signals to the respective inputs of an associated receive phase shifter **150**. The receive phase shifter **150** applies a phase taper to each received RF signal input thereto that sets the tilt angle for the receive antenna beam and then combines the received RF signals into a composite RF signal. The output of each receive phase shifter **150** is coupled to a respective receive port **110**.

[0090] While FIGS. 1B and 2 show an antenna having two linear arrays **120** of ten low-band radiating elements **122** each and two linear arrays **130** of fifteen high-band radiating elements **132** each, it will be appreciated that the number of linear arrays **120**, **130** and the number of radiating elements **122**, **132** included in each of the linear array **120**, **130** may be varied. It will also be appreciated that duplexing may be done in the radios instead of in the antenna **100**, that the number(s) of radiating elements **122**, **132** per sub-array may be varied, that different types of radiating elements may be used (including single polarization radiating elements) and that numerous other changes may be made to the base station antenna **100** without departing from the scope of the present invention.

[0091] As can be seen from FIG. 2, the base station antenna **100** may include a total of sixteen phase shifters **150**. While the two transmit phase shifters **150** for each linear array **120**, **130** (i.e., one transmit phase shifter **150** for each polarization) may not need to be controlled independently (and the same is true with respect to the two receive phase shifters **150** for each linear array **120**, **130**), there still are eight sets of two phase shifters **150** that should be independently controllable. Accordingly, eight mechanical linkages may be required to connect the eight sets of phase shifters **150** to respective RET actuators.

[0092] Each phase shifter **150** shown in FIG. 2 may be implemented, for example, as a rotating wiper phase shifter. The phase shifts imparted by a phase shifter **150** to each sub-component of an RF signal may be controlled by a mechanical positioning system that physically changes the position of the rotating wiper of each phase shifter **150**, as will be explained with reference to FIG. 3. It will be

appreciated that other types of phase shifters may be used instead of rotating wiper phase shifters such as, for example, trombone phase shifters, sliding dielectric phase shifters and the like.

[0093] Referring to FIG. 3, a dual rotating wiper phase shifter assembly **200** is illustrated that may be used to implement, for example, two of the phase shifters **150** of FIG. 2. The dual rotating wiper phase shifter assembly **200** includes first and second phase shifters **202**, **202a**. In the description of FIG. 3 that follows it is assumed that the two phase shifters **202**, **202a** are each transmit phase shifters that have one input and five outputs. It will be appreciated that if the phase shifters **202**, **202a** are instead used as receive phase shifters then the terminology changes, because when used as receive phase shifters there are five inputs and a single output.

[0094] As shown in FIG. 3, the dual phase shifter **200** includes first and second main (stationary) printed circuit boards **210**, **210a** that are arranged back-to-back as well as first and second rotatable wiper printed circuit boards **220**, **220a** (wiper printed circuit board **220a** is barely visible in the view of FIG. 3) that are rotatably mounted on the respective main printed circuit boards **210**, **210a**. The wiper printed circuit boards **220**, **220a** may be pivotally mounted on the respective main printed circuit boards **210**, **210a** via a pivot pin **222**. The wiper printed circuit boards **220**, **220a** may be joined together at their distal ends via a bracket **224**.

[0095] The position of each rotatable wiper printed circuit board **220**, **220a** above its respective main printed circuit board **210**, **210a** is controlled by the position of a drive shaft **228** (partially shown in FIG. 3), the end of which may constitute one end of a mechanical linkage. The other end of the mechanical linkage (not shown) may be coupled to an output member of a RET actuator.

[0096] Each main printed circuit board **210**, **210a** includes transmission line traces **212**, **214**. The transmission line traces **212**, **214** are generally arcuate. In some cases the arcuate transmission line traces **212**, **214** may be disposed in a serpentine pattern to achieve a longer effective length. In the example illustrated in FIG. 3, there are two arcuate transmission line traces **212**, **214** per main printed circuit board **210**, **210a** (the traces on printed circuit board **210a** are not visible in FIG. 3), with the first arcuate transmission line trace **212** being disposed along an outer circumference of each printed circuit board **210**, **210a**, and the second arcuate transmission line trace **214** being disposed on a shorter radius concentrically within the outer transmission line trace **212**. A third transmission line trace **216** on each main printed circuit board **210**, **210a** connects an input pad **230** on each main printed circuit board **210**, **210a** to an output pad **240** that is not subjected to an adjustable phase shift.

[0097] The main printed circuit board **210** includes one or more input traces **232** leading from the input pad **230** near an edge of the main printed circuit board **210** to the position where the pivot pin **222** is located. RF signals on the input trace **232** are coupled to a transmission line trace (not visible in FIG. 3) on the wiper printed circuit board **220**, typically via a capacitive connection. The transmission line trace on the wiper printed circuit board **220** may split into two secondary transmission line traces (not shown). The RF signals are capacitively coupled from the secondary transmission line traces on the wiper printed circuit board **220** to the transmission line traces **212**, **214** on the main printed circuit board. Each end of each transmission line trace **212**,

214 may be coupled to a respective output pad 240. A coaxial cable 260 or other RF transmission line component may be connected to input pad 230. A respective coaxial cable 270 or other RF transmission line component may be connected to each respective output pad 240. As the wiper printed circuit board 220 moves, an electrical path length from the input pad 230 of phase shifter 202 to each output pad 240 changes. For example, as the wiper printed circuit board 220 moves to the left it shortens the electrical length of the path from the input pad 230 to the output pad 240 connected to the left side of transmission line trace 212 (which connects to a first sub-array of radiating elements), while the electrical length from the input pad 230 to the output pad 240 connected to the right side of transmission line trace 212 (which connects to a second sub-array of radiating elements) increases by a corresponding amount. These changes in path lengths result in phase shifts to the signals received at the output pads 240 connected to transmission line trace 212 relative to, for example, the output pad 240 connected to transmission line trace 216.

[0098] The second phase shifter 202a may be identical to the first phase shifter 202. As shown in FIG. 3, the rotating wiper printed circuit board 220a of phase shifter 202a may be controlled by the same drive shaft 228 as the rotating wiper printed circuit board 220 of phase shifter 202.

[0099] As noted above, a RET actuator is used to drive the moveable element of a phase shifter 150. FIG. 4 is a perspective view of an example RET actuator that may be used in the base station antennas according to embodiments of the present invention. The RET actuator 300 is a multi-RET actuator that includes multiple output members that can drive multiple respective mechanical linkages.

[0100] As shown in FIG. 4, the multi-RET actuator 300 includes a housing 310 and a pair of connectors 320 that are mounted so as to extend through the housing 310. The connectors 320 may connect to communications cables that may be used to deliver control signals from a base station control system to the multi-RET actuator 300.

[0101] The multi-RET actuator 300 further includes eight generally parallel worm gear shafts 340 that extend along respective parallel axes (only four of the worm gear shafts 340 are visible in FIG. 4). The worm gear shafts 340 are rotatably mounted in the housing 310. A drive motor (not shown) may be mounted in the housing 310 that may be used to rotate a selected one of the worm gear shafts 340. Various selection mechanisms may also be mounted within the housing 310 that may be used to select one of the worm gear shafts 340 so that the drive motor is operatively connected to the selected worm gear shaft 340.

[0102] An internally threaded piston 350 is mounted on each worm gear shaft 340 and is configured (e.g., via threads) to move axially relative to the worm gear shaft 340 upon rotation of the worm gear shaft 340. Each piston 350 may be connected to a mechanical linkage (not shown) that connects the piston 350 to a moveable element on one or more phase shifters of the antenna, such that axial movement of the piston 350 can be used to apply a phase taper to the sub-components of RF signals that are transmitted and received through a linear array of the antenna. Each piston 350 may be moved in either direction along its associated worm gear shaft 340 by changing the direction of rotation of the worm gear shaft 340.

[0103] FIG. 5 is a rear view of a portion of the base station antenna 100 that shows how mechanical linkages 160 are

used to connect the output members of the RET actuator 300 (i.e., the pistons 350) to moveable elements of respective pairs of phase shifters 150. In FIG. 5, only a few of the elements have been given reference numerals to simplify the drawing (e.g., only one of the mechanical linkages and two of the phase shifters are given reference numerals).

[0104] As shown in FIG. 5, a multi-RET actuator 300 is mounted in the antenna 100 behind the backplane 112. Eight pairs of phase shifters 150 are also mounted rearwardly of the backplane 112 (only four pairs of phase shifters are visible in FIG. 5). Since the base station antenna 100 has linear arrays 120, 130 that are formed of dual-polarized radiating elements 122, 132, the phase shifters 150 are mounted in pairs since the phase shifter 150 for each polarization will be adjusted the same amount. In FIG. 5, phase shifters 150-1 and 150-2 are used to adjust the phase tapers applied to the first and second polarization radiators of the radiating elements 122 of linear array 120-1.

[0105] As is further shown in FIG. 5, a plurality of mechanical linkages 160 are provided that connect each output member 350 of the multi-RET actuator 300 to a respective pair of phase shifters 150. For example, mechanical linkage 160-1 is connected between one of the pistons 350 of RET actuator 300 and a slider 154 of the phase shifter assembly that engages and rotationally moves the respective wiper arms 152 of phase shifters 150-1 and 150-2. As shown in FIG. 5, the mechanical linkage 160-1 includes a first RET rod 162 that is attached to the piston 350 of multi-RET actuator 300, a second RET rod 166, a first RET linkage 164 that connects the first RET rod 162 to the second RET rod 166, and the slider 154 that engages the wiper arms 152 of the phase shifters 150-1, 150-2. The RET rods 162, 166 may comprise, for example, generally rigid fiberglass longitudinally-extending rods. The other three mechanical linkages 160 shown in FIG. 5 include similar combinations of RET rods 162, 166 and RET linkages 164. The RET rods 162, 166 typically extend in a longitudinal direction of the antenna 100, while the RET linkages 164 typically extend along the width and/or depth axes to connect two RET rods 162, 166 together, and/or to connect a RET rod 162, 166 to an output member of the RET actuator or to a moveable element of a phase shifter assembly such as the slider 154 that engages the wiper arms 152. Each mechanical linkage 160 is used to transfer a linear movement of the output member 350 of the RET actuator 300 to a slider 154, although in other embodiments rotational movement may be transferred by the mechanical linkage.

[0106] As can be seen from FIG. 5, the mechanical linkages 160 typically include multiple RET rods 162, 166 and/or multiple RET linkages 164 because the output members of the RET actuator(s) 350 are typically not longitudinally aligned with the moveable elements 152, 154 of the phase shifters 150. Offsets or "jogs" along the width and/or depth axes may also be required in a mechanical linkage 160 in order to route the mechanical linkage 160 around other elements in the antenna 100. Moreover, each RET linkage 164 typically spans different distances in the width and/or depth directions as compared to other ones of the RET linkages 164. As a result, a base station antenna manufacturer may need to manufacture and maintain in inventory a wide variety of different RET linkages 164.

[0107] For example, FIGS. 6A-6G are perspective views of conventional RET linkages that are designed to span different widths and/or depths. In particular, FIGS. 6A and

6B illustrate RET linkages that span different widths with no change in depth. As shown in FIG. 6A, a conventional RET linkage 400 includes a first connection element 402, a second connection element 404 and a connecting member 406 that connects the first connection element 402 to the second connection element 404. FIG. 6B shows a similar conventional RET linkage 410 that includes a first connection element 412, a second connection element 414 and a connecting member 416, with the only significant difference between the RET linkages 400 and 410 is that RET linkage 410 has a longer connecting member 416 than the connecting member 406 of RET linkage 400, so that RET linkage 410 can be used to connect two elements of a mechanical linkage 160 that are spaced farther apart in the width direction. RET linkages 400 and 410 are designed to connect elements of a mechanical linkage 160 (e.g., first and second RET rods 162, 166) that are spaced apart from each other in the width direction but at the same depth behind the backplane 112.

[0108] FIGS. 6C and 6D illustrate conventional RET linkages that are used to connect two elements of a mechanical linkage that are spaced apart in both the width and depth directions. The RET linkage 420 shown in FIG. 6C includes a first connection element 422, a second connection element 424 and a connecting member 426. The connecting member 426 extends at an acute angle between the first and second connecting elements 422, 424, thereby configuring the RET linkage 420 to connect two elements of a mechanical linkage 160 that are spaced apart in both the width and depth directions. The RET linkage 430 shown in FIG. 6D includes a similar design, having a first connection element 432, a second connection element 434 and a connecting member 436. The RET linkage 430 is designed to connect two elements of a mechanical linkage 160 that are spaced apart by a relatively large distance in the depth direction.

[0109] RET rods such as RET rods 162, 166 in FIG. 5 often have generally square or rectangular cross-sections. Moreover, in many cases, different RET rods 162, 166 in a mechanical linkage 160 may be angularly rotated with respect to one another. For example, when a RET rod 166 having a generally rectangular cross-section is attached to a phase shifter 150, typically a side of the RET rod 162, 166 will be coplanar with the backplane 112 of the antenna 100. However, when a multi-RET actuator such as the multi-RET actuator 300 of FIG. 4 is used that has output members 350 that are arranged along the circumference of a cylinder, at least some of the RET rods 162 that attach to the output members of the RET actuator 300 may be angled with respect to the backplane 112 of the antenna 100. As a result, a RET linkage 164 that is designed to connect these two different types of RET rods 162, 166 may require first and second connection elements that are at different angular rotations. Examples of such RET linkages are shown in FIGS. 6E and 6F.

[0110] In particular, as shown in FIG. 6E, a conventional RET linkage 440 includes a first connection element 442, a second connection element 444 and a connecting member 446. The first and second connection elements 442, 444 have different angular rotations, and thus the RET linkage 440 is designed to connect two RET rods 162, 166 that have different angular rotations. FIG. 6F illustrates a conventional RET linkage 450 that includes a first connection element 452, a second connection element 454 and a connecting

member 456 that has a similar design to RET linkage 440 but which accommodates a different angular rotation.

[0111] Finally, in some instances, RET linkages may be designed to avoid other stationary elements in an antenna. For example, FIG. 6G illustrates a conventional RET linkage 460 that includes a first connection element 462, a second connection element 464 and a connecting member 466. The connecting member 466 includes a pair of ramps 467 that are connected by a planar segment 468. The ramps 467 may be used to change the depth of the planar segment 468 so that the connecting member 466 may not run into another element of a base station antenna (not shown) when a mechanical linkage that includes RET linkage 460 moves during normal operation.

[0112] FIG. 7 is a perspective view of an adjustable RET linkage 500 according to embodiments of the present invention. As shown in FIG. 7 the adjustable RET linkage 500 includes a first link 510-1 that has a first connection element 512 that connects to a first RET rod 162, a second link 510-2 that has a second connection element 512 that connects to a second RET rod 166, and a connecting member 520 that connects the first link 510-1 to the second link 510-2. In the embodiment of FIG. 7, the connecting member 520 comprises a pair of links 530-1, 530-2 that are pivotally connected to each other. As can also be seen in FIG. 7, the first link 510-1 is pivotally connected to the one end of the connecting member 520 and the second link 510-2 is pivotally connected to the other end of the connecting member 520. Thus, the adjustable RET linkage 500 pivots in three different locations which allows the adjustable RET linkage 500 to span a wide range of distances in the width and depth directions. The adjustable RET linkage 500 also includes locking mechanisms (discussed below) that can be used to lock each pivotal connection in a respective configuration so that after the adjustable RET linkage 500 has been adjusted to connect two elements (e.g., RET rods 162, 166) of a mechanical linkage 160, the three pivoting connections may be fixed so that the adjustable RET linkage 500 is transformed into a rigid element that efficiently transfers force between the two elements of a mechanical linkage 160.

[0113] As shown in FIG. 7, the first and second links 510-1, 510-2 may be identical in some embodiments. The first connection element 512 extends downwardly from the first link 510-1 and may be used to mount the first link 510-1 on the first RET rod 162. In the depicted embodiment, the connection elements 512 each comprise a series of posts that are received within corresponding cylindrical holes in respective first and second RET rods 162, 166 (not shown in FIGS. 12A-12B) along with a pair of snap clips that hold the respective RET rods 162, 166 in place with the posts inserted into the holes in the RET rods 162, 166. It will be appreciated, however, that any of a wide variety of connection elements may be used such as posts, screws, hook and link fasteners, recesses, and the like. The connection elements 512 may comprise male connection elements that mate with female connection elements on the RET rods, female connection elements that mate with male connection elements on the RET rods, a combination of male and female connection elements and/or connection elements that are neither male nor female in character.

[0114] The first link 510-1 further includes one or more annular receptacles 514. In the depicted embodiment, the first link 510-1 includes a first pair of spaced apart and longitudinally-aligned annular receptacles 514 that extend

upwardly from a first side of the first link **510-1** and a second pair of spaced apart and longitudinally-aligned annular receptacles **514** that extend upwardly from a second side of the first link **510-1** that is opposite the first side. One of the pairs of annular receptacles **514** may comprise part of a first hinge **540-1**, as will be discussed below. By providing one or more annular receptacles **514** on each side of the first link **510-1**, the first hinge **540-1** may be formed to extend from either side of the first link **510-1**. The second link **510-2** may be identical to the first link **510-1**, and hence further description thereof will be omitted.

[0115] The connecting member **520** includes a third link **530-1** and a fourth link **530-2**. The third and fourth links **530-1**, **530-2** may each extend in the width and/or depth directions. In the depicted embodiment, the third and fourth links **530-1** and **530-2** may be identical to each other. Each link **530-1**, **530-2** includes a planar segment **532** and one or more annular receptacles **534**. In the depicted embodiment, each link **530** includes a first annular receptacle **534** that extends from a first side of the planar segment **532** and second and third annular receptacles **534** that are arranged as a pair of spaced apart and longitudinally-aligned annular receptacles **534** that extend from a second side of each link **530**. The first annular receptacle **534** on the third link **530-1** may, together with one of the pairs of annular receptacles **514** included on the first link **510-1**, form the first hinge **540-1** that provides the pivotal connection between the first link **510-1** and the third link **530-1**. The first annular receptacle **534** on the fourth link **530-2** may, together with one of the pairs of annular receptacles **514** included on the second link **510-2**, form a second hinge **540-2** that provides the pivotal connection between the second link **510-2** and the fourth link **530-2**. The pairs of annular receptacles **534** on the third and fourth links **530** are intermeshed to form a third hinge **540-3** that provides the pivotal connection between the third link **530-1** and the fourth link **530-2**. While not visible in FIG. 7, it will be appreciated that a bolt or rod may be inserted through the annular receptacles **514**, **535** that form each of the first through third hinges **540-1** through **540-3**.

[0116] The adjustable RET linkage **500** may further include locking mechanisms that may be used to lock the first through third hinges **540-1** through **540-3** in place so that each hinge **540** becomes fixed once the adjustable RET linkage **500** has been installed on two members **162**, **166** of a mechanical linkage **160**. Any appropriate locking mechanism may be used. As one simple example, an adhesive such as glue could be used to fix each hinge **540** at a desired angle. FIG. 14A illustrates another locking mechanism **550** in which slots **552** are formed through the sidewalls of the annular receptacles **514**, **534** that form each hinge **540**. A pin **554** may be inserted through the slots **552** of the annular receptacles **514**, **534** to render the hinge **540** formed thereby immobile. FIG. 14B illustrates yet another locking mechanism **560** in which mating teeth **562** are formed along the edges of adjacent annular receptacles **514**, **534**. These teeth **562** may increase the force necessary to rotate each hinge **540** so that the hinge **540** will effectively remain locked in a desired position. Numerous other suitable locking mechanisms will be apparent to those of skill in the art.

[0117] The first through third hinged connections **540-1** through **540-3** allow the adjustable RET linkage **500** to be fixed to extend for any of a range of different widths and/or different depths. This allows the adjustable RET linkage **500**

to be used to connect two RET rods that are spaced apart by any distance in the width and/or depths directions within this range, as is shown in FIGS. 8A-8D.

[0118] In particular, as shown in FIGS. 8A and 8B, the three hinged connections **540-1** through **540-3** allow the adjustable RET linkage **500** to span a range of different distances in the width and depth directions between two RET rods **162**, **166**. FIG. 8A illustrates an example where the first RET rod **162** is located farther behind the backplane **112** than the second RET rod **166**. FIG. 8B illustrates an example where the first RET rod **162** is located closer to the backplane **112** than the second RET rod **166**. FIGS. 8A and 8B also illustrate how the hinges **540-1** through **540-3** allow the adjustable RET linkage **500** to span different widths. For example, in FIG. 8A, the adjustable RET linkage **500** is configured to connect first and second RET rods **162**, **166** that are separated by a distance **W1** in the width direction and a distance **D1** in the depth direction, while in FIG. 8B the adjustable RET linkage **500** is configured to connect first and second RET rods **162**, **166** that are separated by a distance **W2** in the width direction that is less than distance **W1** and a distance **D2** in the depth direction that is greater than distance **D1**.

[0119] FIGS. 8C and 8D similarly show how the adjustable RET linkage **500** may be used to connect first and second RET rods **162**, **166** that are at the same depth behind the backplane and separated by a third distance **W3** in the width direction or may alternatively be used to connect first and second RET rods **162**, **166** that are at the same depth behind the backplane and separated by a fourth distance **W4** in the width direction that is less than distance **W3**.

[0120] As can best be seen in FIGS. 8A and 8B, the distance in the width direction spanned by the adjustable RET linkage **500** may be increased by increasing the angle α defined by the third and fourth links **530-1**, **530-2** that are connected by the third hinge **540-3**. The distance in the width direction spanned by the adjustable RET linkage **500** may also be increased by changing the angle defined by the first hinge **540-1** and/or by changing the angle defined by the second hinge **540-2**. Likewise the distance in the depth direction spanned by the adjustable RET linkage **500** may be increased by increasing any or all of the above-referenced angles.

[0121] As can best be seen in FIG. 8D, in some cases the adjustable RET linkage **500** may be set so that the angle α is relatively small. As the angle α decreases, the overall height of the adjustable RET linkage **500** itself increases. This may be problematic in some antenna designs where the adjustable RET linkage **500** needs to be located a small distance from the backplane or some other element within the antenna. FIGS. 9A and 9B are a perspective view and a side view, respectively, of an adjustable RET linkage **600** according to further embodiments of the present invention that extends a smaller distance in the depth direction.

[0122] As shown in FIGS. 9A and 9B, according to further embodiments of the present invention, an adjustable RET linkage **600** is provided that may be identical to the adjustable RET linkage **500** except that the length of at least one of the third and fourth links **530-1**, **530-2** of adjustable RET linkage **500** may be replaced with a different part in adjustable RET linkage **600**. In particular, as shown in FIGS. 9A-9B, if one of the two identical links **530-1**, **530-2** of adjustable RET linkage **500** is replaced with a shorter link **530-2'**, the overall height of the adjustable RET linkage **500**

when configured to span a first distance in the width direction may be reduced. The use of the shorter link **530-2'**, however, may reduce the range of distances in the width and depth directions that can be spanned by the adjustable RET linkage **600**.

[0123] Referring next to FIG. **10A**, it can be seen that the adjustable RET linkages according to embodiments of the present invention also provide flexibility with respect to the rotational angle of the first and second links. For example, in antennas that use multi-RET actuators that have a cylindrical design such as the multi-RET actuator **300** of FIG. **4**, different RET rods **162**, **166** in a mechanical linkage **160** may have different angular rotations. If a conventional mechanical linkage is used in such antennas, it typically is necessary to design the mechanical linkage to have RET linkages with connection members that extend at appropriate rotational angles to mate with the RET rods **162**, **166**. This further increases the number of conventional RET linkages that must be designed and maintained in inventory. In contrast, FIG. **10A** illustrates how the first hinge on the adjustable RET linkage **600** of FIGS. **9A-9B** may be rotated so that the first connection element **512** on the first link **510-1** may be positioned at a wide range of rotational angles for attachment to a RET rod **162** or other member of a mechanical linkage **160**. While not shown in FIGS. **10A** and **10B**, the same flexibility is provided for the second link **510-2**, and the adjustable RET linkage **500** of FIGS. **7-8D** can similarly accommodate a wide range of angular rotations. FIG. **10B** illustrates how the fourth link **530-2'** may be positioned downwardly instead of upwardly in order to accommodate clearance requirements in the antenna.

[0124] While the adjustable RET linkage **500** of FIG. **7** includes a two-piece connecting member **520**, it will be appreciated that other designs are possible. For example, FIGS. **11A-11C** illustrate an adjustable RET linkage **700** according to embodiments of the present invention that includes a single-piece connecting member **720**. The adjustable RET linkage **700** may have less flexibility for spanning different spacing and angular offsets, but may be sufficient for many applications and may be simpler and cheaper to manufacture. In other embodiments (not shown), the connecting members may include more than two links.

[0125] While the adjustable RET linkages **500**, **600** and **700** each use hinges that provide pivotable connections between the different links, it will be appreciated that embodiments of the present invention are not limited thereto. For example, FIGS. **12A** and **12B** illustrate an adjustable RET linkage **800** according to further embodiments of the present invention that includes sliding links that may be used to accommodate different distances in the width and depth directions between RET rods or other elements of a mechanical linkage. As shown in FIGS. **12A-12B**, the adjustable RET linkage **800** includes a first link **810-1** that has a first connection element **812** mounted thereon and a second link **810-2** that has a second connection element **812** mounted thereon. In the depicted embodiment, the connection elements **812** each comprise a series of posts **814** that are received within corresponding cylindrical holes in respective first and second RET rods **162**, **166** (not shown in FIGS. **12A-12B**) along with a pair of snap clips **816** that hold the respective RET rods **162**, **166** in place with the posts **814** inserted into the holes in the RET rods **162**, **166**. It will be appreciated, however, that any of a wide variety of connection elements may be used.

[0126] The adjustable RET linkage **800** further includes a connecting member **820** that connects the first link **810-1** to the second link **810-2**. In the embodiment of FIGS. **12A-12B**, the connecting member **820** comprises third and fourth links **830-1**, **830-2** that are slidably connected to each other. As can also be seen in FIGS. **12A** and **12B**, the first link **810-1** is slidably connected to the third link **830-1** and the second link **810-2** is slidably connected to the fourth link **830-2**. Thus, the adjustable RET linkage **800** includes two links that can slide in the width direction plus a third link that can slide in the depth direction which allows the adjustable RET linkage **800** to span a wide range of distances in the width and depth directions. The adjustable RET linkage **800** also includes locking mechanisms (not shown) that can be used to lock each slidable link in place. Glue or epoxy are possible locking mechanisms, as are pin-and-slot or saw-tooth locking mechanisms as discussed above with reference to the adjustable RET linkage **500**. The connections elements **812** may be any suitable mechanism for connecting the adjustable RET linkage **800** to a RET rod or other element of a mechanical linkage.

[0127] Pursuant to still further embodiments of the present invention, adjustable RET linkages are provided that have selectable positions so that the RET linkage may be pre-adjusted when assembled to have a desired span. FIG. **13A** is a perspective view of one such adjustable RET linkage **900**. FIGS. **13B** and **13C** are side views of the adjustable RET linkage **900**.

[0128] As shown, the adjustable RET linkage **900** includes a single-link connecting member **920** that may be identical to the single link connecting member **720** of adjustable RET linkage **700**, except that the connecting member **900** includes several additional annular receptacles **924** that extend through central portions of the connecting member **920**. As shown in FIGS. **13B** and **13C**, the inclusion of the additional annular receptacles **924** allows the connecting member **920** to effectively be shortened or lengthened by selecting the annular receptacle that is used to form the second hinge **940-2**.

[0129] FIG. **15** is a schematic side view of a connecting member **1020** that may be used in adjustable RET linkages according to further embodiments of the present invention. As shown in FIG. **15**, the connecting member **1020** includes three links **1030-1** through **1030-3** and two hinged connections **1040-1** and **1040-2**. This allows the connecting member to have the shape of the conventional connecting member **460** illustrated in FIG. **6G**.

[0130] It will also be appreciated that a base station antenna manufacturer may stock a small number of parts that can be used to form many different adjustable RET linkages that may be sufficient to support numerous lines of base station antennas. For example, a base station antenna manufacturer might stock each of the different pieces necessary to form the adjustable RET linkage **500** of FIG. **7**, along with a few additional connecting member links that have different lengths (such as link **530-2'** of FIGS. **9A**, **9B**), a few links having the design of connecting member **920** of FIGS. **13A-13C** and a few links (of different lengths) having the design of link **1030-3** of FIG. **15**. This small number of parts could be used to form adjustable RET linkages that could span almost any necessary distance in the width and depth directions by varying the links included in the RET linkage and the number of links/hinged connections used.

[0131] It will be appreciated that the above embodiments are intended as examples only, and that a wide variety of different embodiments fall within the scope of the present invention. It will also be appreciated that any of the above embodiments may be combined. For example, adjustable RET linkages may be provided that include both sliding links and pivoting links. It will also be appreciated that the connecting members may include more than two links, and that the three or more connecting links may be connected by hinged and/or sliding connections. Such a design may be particularly advantageous when the RET linkage needs to have a shape similar to that shown in FIG. 6G in order to avoid running into other structures within the antenna.

[0132] Pursuant to further embodiments of the present invention, adjustable RET linkages are provided that are formed from one or more standardized parts and one or more of a plurality of changeable parts. For example, two standardized parts and one of the plurality of changeable parts may be interconnected to form the adjustable RET linkage. These RET linkages are “adjustable” in the sense that different changeable parts may be interconnected with the standardized parts in order to adjust the distances spanned by the RET linkage in, for example, the width and/or depth directions of the base station antenna. The standardized parts may comprise parts that are configured for connection to a RET rod, while the changeable parts may comprise parts that are configured to span different distances in the width and/or depth directions. A changeable part may be used to connect two standardized parts together. The standardized and changeable parts may include mating features that allow each changeable part to readily be interconnected between a pair of standardized parts to form the adjustable RET linkage.

[0133] FIG. 16A is a perspective view of an example embodiment of an adjustable RET linkage 1100 according to embodiments of the present invention that is formed by interconnecting standardized and changeable parts. FIG. 16B is a perspective view illustrating how the adjustable RET linkage 1100 of FIG. 16A may be used to connect two RET rods. FIG. 17A is a perspective view of a standardized part that is included in the adjustable RET linkage 1100 of FIGS. 16A-16B. FIG. 17B is an enlarged perspective view of an end portion of the standardized part of FIG. 17A. FIGS. 18A and 18B are perspective views of two example changeable parts that may be used to form the adjustable RET linkage 1100 of FIGS. 16A-16B, while FIGS. 18C and 18D are side views of two additional example changeable parts that may be used to form the adjustable RET linkage 1100 of FIGS. 16A-16B.

[0134] As shown in FIGS. 16A-16B the adjustable RET linkage 1100 includes a first standardized part 1110-1 that connects to a first RET rod 162, a second standardized part 1110-2 that connects to a second RET rod 166, and a changeable connecting member 1120 that connects the first standardized part 1110-1 to the second standardized part 1110-2. In FIG. 16A, the adjustable RET linkage 1100 is depicted prior to attachment of the first and second standard parts 1110-1, 1110-2 to the respective first and second RET rods 162, 166 in order to better show the adjustable RET linkage 1100. The first and second standardized parts 1110-1, 1110-2 may be identical in some embodiments such that only a single standardized part design may be required in some cases. Since the first and second standardized parts 1110-1, 1110-2 have the same design in the embodiment of

FIGS. 16A-16B, they will be described together below as a generic standardized part 1110 with reference to FIGS. 17A and 17B.

[0135] Referring to FIGS. 16A-16B and 17A, each standardized part 1110 includes a first connection element 1112 that is used to connect the standardized part 1110 to a RET rod and a second connection element 1115 that is used to connect the standardized part 1110 to a selected one of a plurality of changeable connecting members 1120. The first connection element 1112 comprises a recess 1111, a plurality of posts 1113 and a pair of snap clips 1114. The recess 1111 extends along the longitudinal direction of the RET rod to which the standardized part 1110 is to be attached, and may be sized so that the RET rod may be received within the recess 1111 and the walls of the recess 1111 may prevent relative lateral movement of the RET rod with respect to the standardized part 1110. The posts 1113 are mounted in the base of the recess 1111 and are sized to be received within corresponding holes in the RET rod. The posts 1113, when received within the corresponding holes in the RET rod, may prevent longitudinal movement of the standardized part 1110 relative to the RET rod received therein. The snap clips 1114 extend from the base of the recess 1111 and are designed to prevent vertical movement of the standardized part 1110 relative to the RET rod. The first connection element 1112 may allow the standardized part to be easily snapped onto a RET rod and, once in place, the standardized part 1110 will remain in a fixed position relative to the RET rod. While FIGS. 16A-16B and 17A illustrate one example first connection element 1112, it will be appreciated that any of a wide variety of first connection elements may be used such as, for example, any suitable combination of one or more posts, screws, hook and link fasteners, recesses, and the like. The connection elements 1112 may comprise male connection elements that mate with female connection elements on the RET rods, female connection elements that mate with male connection elements on the RET rods, a combination of male and female connection elements and/or connection elements that are neither male nor female in character.

[0136] The second connection element 1115 is used to connect the standardized part 1110 to a selected one of a plurality of changeable connecting members 1120. The second connection element 1115 comprises a bottom plate 1116, one or more top plates 1117, and one or more supports 1118 that connect the bottom plate 1116 and top plates 1117 and maintain the plates 1116, 1117 in a spaced-apart relationship. The space between the bottom plate 1116 and the top plate(s) 1117 may be sized to receive a third connection element 1124 (described below) of the selected one of the plurality of changeable connecting members 1120. The third connection element 1124 of the changeable connecting member 1120 may snap-in to the space between the bottom plate 1116 and the top plate(s) 1117.

[0137] As can be seen best in FIG. 17B, several detents 1119 may be provided, for example, on the bottom surfaces of one or more of the top plates 1117 and may prevent the changeable connecting member 1120 from disconnecting from the standardized part 1110 once the changeable connecting member 1120 is snapped into the second connection element 1115. The bottom and top plates 1116 and 1117 may prevent vertical movement (i.e., movement in the depth direction of the antenna) of the changeable connecting member 1120 relative to the standardized part 1110, and the support 1118 may prevent longitudinal movement of the

changeable connecting member **1120** relative to the standardized part **1110**. The detents **1119** may prevent lateral movement (i.e., movement in the width direction of the antenna) of the changeable connecting member **1120** relative to the standardized part **1110**.

[0138] Referring to FIG. **18A**, a changeable connecting member **1120A** is illustrated that may connect the first standardized part **1110-1** to the second standardized part **1110-2**. The changeable connecting member **1120A** comprises a connecting piece **1122A** that traverses a desired distance in the, for example, the width and depth directions. In the depicted embodiment, the connecting piece **1122A** comprises a flat plate-like structure that extends for a desired distance **W1** in the width direction and that does not extend (other than the thickness of the plate-like structure) in the depth direction. The connecting member **1120A** further comprises a pair of third connection elements **1124** that are formed at opposed ends of the connecting piece **1122A**. In the depicted embodiment, each third connection element **1124** comprises a series of slots and/or holes that are formed along the edges of the plate-like connecting piece **1122A**. As discussed above, each third connection element **1124** mates with a second connection element **1115** of a respective standardized part **1110** in order to interconnect the changeable connecting member **1120A** with a pair of standardized parts **1110** in order to form the adjustable RET linkage **1100**.

[0139] As shown in FIGS. **16A-16B**, when the adjustable RET linkage **1100** includes the particular changeable connecting member **1120A** shown in FIG. **18A**, the adjustable RET linkage **1100** may be used to connect two RET rods that are at the same depth from a reference plane within the base station antenna and that are spaced apart in the width direction by a distance **W2** in the width direction which is slightly greater than the distance **W1** in the width direction.

[0140] FIGS. **18B-18D** illustrate three additional changeable connecting members **1120B**, **1120C**, **1120D** that may be used in place of changeable connecting member **1120A** so that the adjustable RET linkage **1100** may be adjusted to span different distances in the width and/or depth directions. For example, referring to FIG. **18B**, it can be seen that the changeable connecting member **1120B** is identical to the changeable connecting member **1120A** except that the changeable connecting member **1120B** has a connecting piece **1122B** that extends for a distance **W3** in the width direction that is greater than the distance **W2** in the width direction. Thus, in order to connect two RET rods that are spaced farther apart in the width direction than the RET rods **162**, **166** shown in FIG. **16B**, changeable connecting member **1120B** may be used to form the RET linkage **1100** instead of changeable connecting member **1120A**.

[0141] The changeable connecting members **1120C** and **1120D** shown in FIGS. **18C** and **18D**, respectively, are designed to allow the adjustable RET linkage **1100** to connect RET rods that are offset in both the width and depth directions. The width of the connecting members **1120C**, **1120D** in the width direction and the angle α at which the connecting members **1120C**, **1120D** extend with respect to the depth direction may be set so that the adjustable RET linkage **1100** may span any desired distances in the width and depth directions.

[0142] FIG. **19** is a perspective view of an alternative standardized part **1210** for the adjustable RET linkage of FIGS. **16A-16B**. As can be seen by comparing FIG. **19** to FIG. **17A**, the standardized part **1210** is similar to the

standardized part **1110**, and may include a first connection element **1112** that is used to connect the standardized part **1210** to a RET rod and a second connection element **1215** that is used to connect the standardized part **1210** to a selected one of a plurality of changeable connecting members **1220**. The first connection element **1112** is identical to the first connection element **1112** of adjustable RET linkage **1100**, and hence further description thereof will be omitted. The second connection element **1215** comprises three snap clips **1216** as well as six strength members **1217**. Two strength members **1217** are positioned on opposed sides of each of the three snap clips **1216**.

[0143] While not shown in the drawings, two of the standardized parts **1210** of FIG. **19** may be used in conjunction with a plurality of changeable connecting members (not shown) to form an adjustable RET linkage according to further embodiments of the present invention. The two standardized parts **1210** may connect to a respective pair of RET rods and opposed ends of a selected one of the plurality of changeable connecting members that is sized to span the gap between the two standardized parts **1210** may be connected to the respective standardized parts **1210** by inserting the opposed ends of the selected changeable connecting member into the second connection elements **1215** of the standardized parts **1210**. The opposed ends of the changeable connecting member (not shown) may include slots, openings or the like that are configured to receive the snap clips **1216** so that the changeable connecting member will be firmly connected to each standardized part **1210**. The three snap clips **1216** are arranged in to prevent the longitudinal and/or lateral movement of the changeable connecting member relative to the standardized part **1210**. The projections on the distal ends of the snap clips **1216** may prevent vertical movement of the changeable connecting member relative to the standardized part **1210**.

[0144] FIG. **20** is a perspective view of a standardized part **1310** that has two second connection elements and a first connection element. The standardized part **1310** may be used in an adjustable RET linkage according to further embodiments of the present invention that connects more than two RET rods together. FIG. **21A** is a perspective view of an adjustable RET linkage **1300** according to embodiments of the present invention that includes the standardized part **1310** of FIG. **20**. FIG. **21B** is a perspective view illustrating how the adjustable RET linkage **1300** of FIG. **21A** may be used to connect three RET rods together.

[0145] As shown in FIG. **20**, the standardized part **1310** is similar to the standardized part **1110** discussed above with reference to FIGS. **17A-17B**, except that the standardized part **1310** includes two second connection elements **1115** that are positioned on each side of a first connection element **1112**. This arrangement allows the standardized part **1310** to connect to two different changeable connecting members **1120**, which may each have the same design or which may have different designs.

[0146] As shown in FIGS. **21A** and **21B**, the standardized part **1310** may be used in an adjustable RET linkage **1300** that includes, for example, two standardized parts **1110**, two changeable connecting members **1120**, and a standardized part **1310**. Each standardized part **1110**, **1310** may be mounted on a respective RET rod (see FIG. **21B**), and hence the adjustable RET linkage **1300** may be used to connect three RET rods **162**, **166**, **168** together. While not shown in the drawings, it will readily be appreciated that additional

standardized parts **1310** and changeable connecting members **1120** may be added so that the adjustable RET linkage **1300** may be used to connect more than three RET rods. As the standardized parts **1110** and the various changeable connecting members **1120** have been discussed in detail above, further description thereof will be omitted here.

[0147] The standardized parts (e.g., **1110**, **1210**, **1310**) of the adjustable RET linkages according to embodiments of the present invention that exhibit adjustability through the selection of one of a plurality of changeable parts. The standardized parts may be molded plastic parts in some embodiments. Since only one or a few different standardized part designs may be required, the standardized parts may be manufactured using one or a small number of molds and hence may be fabricated in large numbers at very low cost. In some embodiments, the changeable connecting members may be formed of sheet metal by stamping and (when necessary) bending processes. This may allow a large number of different changeable connecting member designs to be fabricated quickly and at relatively low cost. In other embodiments, the changeable connecting members may be formed of plastic or other materials. Thus, by forming the adjustable RET linkages using both standardized parts and a selected one of a plurality of changeable connecting member designs, adjustable RET linkages may be provided that are inexpensive to manufacture and easy to assemble using, for example, snap-in or snap-fit connections.

[0148] The present invention has been described above with reference to the accompanying drawings. The invention is not limited to the illustrated embodiments; rather, these embodiments are intended to fully and completely disclose the invention to those skilled in this art. In the drawings, like numbers refer to like elements throughout. Thicknesses and dimensions of some components may be exaggerated for clarity.

[0149] Spatially relative terms, such as “under”, “below”, “lower”, “over”, “upper”, “top”, “bottom” and the like, may be used herein for ease of description to describe one element or feature’s relationship to another element(s) or feature(s) as illustrated in the figures. It will be understood that the spatially relative terms are intended to encompass different orientations of the device in use or operation in addition to the orientation depicted in the figures. For example, if the device in the figures is turned over, elements described as “under” or “beneath” other elements or features would then be oriented “over” the other elements or features. Thus, the exemplary term “under” can encompass both an orientation of over and under. The device may be otherwise oriented (rotated 90 degrees or at other orientations) and the spatially relative descriptors used herein interpreted accordingly.

[0150] Herein, the terms “attached”, “connected”, “inter-connected”, “contacting”, “mounted” and the like can mean either direct or indirect attachment or contact between elements, unless stated otherwise.

[0151] Well-known functions or constructions may not be described in detail for brevity and/or clarity. As used herein the expression “and/or” includes any and all combinations of one or more of the associated listed items.

[0152] The terminology used herein is for the purpose of describing particular embodiments only and is not intended to be limiting of the invention. As used herein, the singular forms “a”, “an” and “the” are intended to include the plural forms as well, unless the context clearly indicates otherwise.

It will be further understood that the terms “comprises”, “comprising”, “includes” and/or “including” when used in this specification, specify the presence of stated features, operations, elements, and/or components, but do not preclude the presence or addition of one or more other features, operations, elements, components, and/or groups thereof.

1. A base station antenna, comprising:
 - a remote electronic tilt (“RET”) actuator;
 - a phase shifter having a moveable element; and
 - a mechanical linkage extending between the RET actuator and the phase shifter, the mechanical linkage including an adjustable RET linkage that includes a first link that has a first connection element, a second link that has a second connection element and a connecting member that includes at least a third link, wherein the adjustable RET linkage includes at least a first hinge and a second hinge.
2. The base station antenna of claim 1, wherein the first hinge connects the first link to the connecting member.
3. The base station antenna of claim 2, wherein the second hinge connects the second link to the connecting member.
4. The base station antenna of claim 1, wherein the connection member includes the third link and a fourth link that is connected to the third link via a third hinge.
- 5-6. (canceled)
7. The base station antenna of claim 1, wherein the first connection element is attached to a first RET rod of the mechanical linkage.
8. (canceled)
9. A base station antenna, comprising:
 - a remote electronic tilt (“RET”) actuator;
 - a phase shifter having a moveable element; and
 - a mechanical linkage extending between the RET actuator and the phase shifter, the mechanical linkage including a first RET rod, a second RET rod and an adjustable RET linkage that connects the first RET rod to the second RET rod, the adjustable RET linkage including a first connection element that connects to the first RET rod and a second connection element that connects to the second RET rod, wherein the adjustable RET linkage is configured so that a distance between the first connection element and the second connection element is adjustable.
10. The base station antenna of claim 9, wherein the adjustable RET linkage includes at least one hinge.
11. (canceled)
12. The base station antenna of claim 9, wherein the adjustable RET linkage comprises a multi-piece adjustable RET linkage that includes a first link and a second link that are configured to slide relative to one another.
- 13-16. (canceled)
17. The base station antenna of claim 9, wherein the adjustable RET linkage includes at least two hinges.
- 18-19. (canceled)
20. The base station antenna of claim 9, wherein the adjustable RET linkage comprises a multi-piece adjustable RET linkage that includes a first link that includes the first connection element, a second link that includes the second connection element, and third and fourth links that are connected between the first and second links.
21. (canceled)
22. The base station antenna of claim 20, wherein the first link is connected to the third link by a first hinge, the third

link is connected to the fourth link by a second hinge, and the fourth link is connected to the second link by a third hinge.

23. (canceled)

24. A base station antenna, comprising:
a remote electronic tilt (“RET”) actuator;
a phase shifter having a moveable element; and
a mechanical linkage extending between the RET actuator and the phase shifter, the mechanical linkage including a first RET rod and an adjustable RET linkage that connects to the first RET rod, the adjustable RET linkage including a first link and a second link that is configured to move relative to the first link.

25. The base station antenna of claim **24**, wherein the adjustable RET linkage includes at least one hinge.

26. (canceled)

27. The base station antenna of claim **24**, wherein the first link and the second link are configured to slide relative to one another.

28. The base station antenna of claim **24**, wherein the adjustable RET linkage includes a first connection element that connects to the first RET rod and a second connection element, and wherein a distance between the first connection element and the second connection element is adjustable.

29. The base station antenna of claim **28**, wherein the first connection element is rotatable with respect to the second connection element.

30. The base station antenna of claim **24**, wherein the adjustable RET linkage includes at least one additional link that is coupled between the first link and the second link.

31-34. (canceled)

35. The base station antenna of claim **24**, wherein the mechanical linkage is configured to move the moveable element of the phase shifter in response to movement of the RET actuator.

36. A base station antenna, comprising:

a remote electronic tilt (“RET”) actuator;
a phase shifter having a moveable element; and
a mechanical linkage extending between the RET actuator and the phase shifter, the mechanical linkage including a first RET rod, a second RET rod and an adjustable RET linkage that connects the first RET rod to the second RET rod, the adjustable RET linkage including a first connection element that connects to the first RET rod and a second connection element that connects to the second RET rod, wherein the first connection element is rotatable with respect to the second connection element.

37-39. (canceled)

40. The base station antenna of claim **36**, wherein the adjustable RET linkage includes at least three links and at least two hinges. **41-53.** (canceled)

* * * * *