

(19)



(11)

EP 4 365 644 A2

(12)

EUROPEAN PATENT APPLICATION

(43) Date of publication:
08.05.2024 Bulletin 2024/19

(51) International Patent Classification (IPC):
G02B 1/04 (2006.01)

(21) Application number: **24163088.8**

(52) Cooperative Patent Classification (CPC):
**G02C 7/108; B29D 11/00009; B32B 7/12;
B32B 27/08; B32B 27/18; B32B 27/365;
B32B 27/40; G02C 7/10; B29D 11/00634;
B29D 11/0073; B32B 2250/02; B32B 2250/03;
B32B 2250/24; B32B 2307/21; B32B 2307/40;**

(22) Date of filing: **29.09.2016**

(Cont.)

(84) Designated Contracting States:
**AL AT BE BG CH CY CZ DE DK EE ES FI FR GB
GR HR HU IE IS IT LI LT LU LV MC MK MT NL NO
PL PT RO RS SE SI SK SM TR**

- **BLACKER, Richard**
Lino Lakes (US)
- **KISSEL, David J**
Andover (US)
- **OLUND, David**
Stanchfield (US)

(30) Priority: **29.09.2015 US 201562234543 P**

(62) Document number(s) of the earlier application(s) in accordance with Art. 76 EPC:
16852641.6 / 3 356 881

(74) Representative: **KIPA AB**
Drottninggatan 11
252 21 Helsingborg (SE)

(71) Applicant: **HOYA OPTICAL LABS OF AMERICA, INC**
Lewisville TX 75057 (US)

Remarks:

This application was filed on 13-03-2024 as a divisional application to the application mentioned under INID code 62.

(72) Inventors:
• **NAHM, Steven Harold**
Minneapolis (US)

(54) **UV AND HIGH ENERGY VISIBLE ABSORBING OPHTHALMIC LENSES**

(57) An ophthalmic lens operable to protect the eye from harmful ultraviolet and high energy visible wave-

lengths of light and methods for producing the same.

EP 4 365 644 A2

(52) Cooperative Patent Classification (CPC): (Cont.)
B32B 2307/4026; B32B 2307/412; B32B 2307/42;
B32B 2307/71; B32B 2307/73; B32B 2307/732;
B32B 2551/00; G02C 2202/16

Description

RELATED APPLICATIONS

5 **[0001]** This application claims priority to U.S. Provisional Application Serial No. 62/234,543 filed September 29, 2015, entitled UV and High Energy Visible Absorbing Ophthalmic Lenses, which is hereby incorporated herein by reference in its entirety.

FIELD OF THE INVENTION

10 **[0002]** The present invention relates to light absorbing filters, e.g. optical films, laminates, and lenses, and more particularly, to optical filters that absorb harmful ultraviolet and/or high energy visible light.

BACKGROUND OF THE INVENTION

15 **[0003]** It is known in the art to use additives to absorb harmful wavelengths of light, including UV light with wavelengths between 280nm and 380nm under ANSI standards and 400nm under other (AUS/NZ) standards. More recently, it has become apparent that HEV (high energy visible) light which is characterized as having wavelengths from 400nm up to 500nm, also poses possible damage threats to living tissues or the eyes. This light range has also been attributed to other biological factors such as impacts on circadian rhythms.

20 **[0004]** As the absorbed wavelengths of light begin to ingress upon the visible light wavelengths, the result is a visible coloration that under most circumstances is undesirable and due to the blocking of predominantly blue wavelengths, results in a yellow colour or transmission through the absorbing article.

25 **[0005]** In general terms, the lower the wavelength of the light, the higher the energy of the photon, and so the greater the possible cellular damage. Light in these wavelengths carries sufficient energy to break chemical bonds, causing damage to the substrates that absorb this light. These substrates can be of biological origin or other so called organic materials, the latter being defined as compounds consisting predominately of carbon based materials such as synthetic polymers used ubiquitously to make articles of commercial value.

30 **[0006]** When bonds within inanimate substrates are broken, the primary effect is characterized as a loss of mechanical properties or a change in colour. When bonds within living biological tissue are broken, the tissue damage manifests in a degradation or loss of function that can include lesions and burns, damage to genetic material, degradation of vision, and so forth, effects generally leading to decline of the organism's health and potentially shortening its life.

35 **[0007]** The same types of additives that find use in protection of non-living materials can also be effective in protection of living tissue. For example, materials known as sunscreens are widely sold as lotions and creams for topical application to exposed skin tissue, absorbing the harmful rays from the sun and protecting the exposed skin tissue from damage.

40 **[0008]** Compounds most useful in protection against harmful UV and HEV radiation strongly absorb light in these damaging wavelengths, and typically contain one or more structural features with extended π -electron clouds, more accurately described as compounds with formal unsaturation or multiple bonds between individual adjacent atoms alternately separated by single bonds between adjacent atoms. Generic structures meeting this broad description generally contain so-called aromatic groups, the parent structure being represented by benzene. Other arrays of atoms can serve as the basis for their structures, including extended linear or cyclic arrays of alternating carbon to carbon double and single bonds, particularly where one or more carbon atoms is replaced by a heteroatom such as nitrogen, oxygen or sulphur. The wavelengths absorbed by these structures can be tuned by the number, type, and arrangement of the constituent atoms, including adjoined (fused) rings and the presence of substituent heteroatoms not involved in the extended system of multiple bonds, which atoms possess unshared (lone or non-bonding) pairs of electrons. Such heteroatoms include but are not limited to nitrogen, oxygen and sulfur, and halogens, particularly chlorine.

45 **[0009]** The most useful structures for UV and HEV absorption have a mechanism whereby they can harmlessly "dump" the energy they absorb from the incident light by a reversible transformation of the electronic excited state formed (by light absorption) as heat through atomic motion, more correctly, through transfer of a neutral hydrogen atom (H) or a proton (H⁺), from one bonding partner to another, for example between oxygen and nitrogen appropriately arrayed in space, by a process known as tautomerization, a formal rearrangement of atoms and electrons through shifting of single and double bonds. An example of such tautomerization is shown in Fig. 1

50 **[0010]** In the above example, the hydrogen atom transfers from the oxygen atom in the ground state to the neighbouring nitrogen atom in the excited state, accompanied by a shift of π -electrons, and back again with liberation of heat and resulting in no net change to the original structure. Such hydrogen atom transfers or migrations are thought to occur because of increased acidity of the group containing the hydrogen atom in the excited state, such that the basicity of the neighboring heteroatom is strong enough to abstract the hydrogen atom or proton to form a new neutral structure, which may also be represented as one in which there are neighbouring opposite charges in the structure, also called a

betaine. Other structures can be drawn where the hydrogen atom transfers in the opposite sense from a nitrogen atom in the ground state to an oxygen atom in the excited state and between two appropriately positioned oxygen or nitrogen atoms.

5 [0011] Other structures are known where the likely energy conversion is accomplished by breaking of a double bond to form two adjacent stabilized radicals, allowing "free" rotation of the newly generated single bond between these two adjacent free radical centers, with ultimate reformation of the double bond and again, with no net change to the molecular structure. An example of such reaction is shown in Fig. 2.

10 [0012] Such materials can be used separately or in combination with an array of different substituents around the structure, which substituents are selected on the basis of their ability to modify the wavelengths of light absorbed, the stability of the excited state intermediates, and their effects on the solubility or compatibility of the resultant ground state structures in or with the media in which they are dissolved. There is a wide range of commercially available compounds possessing these key reversible structural characteristics, sold as stabilizing additives.

15 [0013] However, there is a need in the ophthalmic field for optimization of eye protection against harmful UV and HEV light in eye wear that is cosmetically acceptable or desirable and, hence, commercially successful.

OBJECTS AND SUMMARY OF THE INVENTION

20 [0014] The present invention provides for the optimization of eye protection against harmful UV and HEV light in eye wear that is cosmetically acceptable or desirable. These objectives are, in part, achieved through providing an ophthalmic article comprising a light absorbing layer having a weight percent of a light absorbing compound in the range of 0.1 to 10 and a transmittance of no more than 50 percent of light having wavelengths of up to 443 nm.

25 [0015] In certain embodiments of the present invention, the light absorbing layer has a weigh percent of a light absorbing compound of up to 3 or of up to 1. In certain embodiments of the present invention, the light absorbing layer has a thickness of greater than 1 mm or 0.01 to 1 mm. In certain embodiments of the present invention, the light absorbing layer has a transmittance of no more than 50 percent of light having wavelengths of up to 410 nm. In certain embodiments of the present invention, the light absorbing layer is a monolithic film, an adhesive layer of a laminate, a component of a composite ophthalmic lens, a thermoplastic resin, or a curable composition.

30 [0016] These objectives are, in part, further achieved through providing a method for forming an ophthalmic article comprising: determining a target transmittance of light below a wavelength of 450 nm for the ophthalmic article; determining a target range of thickness of the ophthalmic article; adding a weight percent of a light absorbing compound to a medium based upon the target transmittance, the target range of thickness, and a target CIE color coordinate for the ophthalmic article; and forming the ophthalmic article with medium containing the light absorbing compound.

35 [0017] In certain embodiments of the present invention, the determining a target transmittance comprises determining a target transmittance of less than 50 percent or determining a transmittance of not more than 50 percent of light having a wavelength of up to 410 nm. In certain embodiments of the present invention, determining a target range of thickness comprises determining a thickness of greater than 1 mm or a thickness in the range of 0.01 to 1 mm. In certain embodiments of the present invention, the adding a weight percent of a light absorbing compound to a medium comprises adding a weigh percent of the light absorbing compound in the range of 1 to 10. In certain embodiments of the present invention, the forming the ophthalmic article comprises forming the ophthalmic article through injection molding of a molten thermoplastic, forming the ophthalmic article through curing of a curable composition, or forming of a composite ophthalmic article having a layer of the medium containing the light absorbing compound.

BRIEF DESCRIPTION OF THE DRAWINGS

45 [0018] These and other aspects, features and advantages of which embodiments of the invention are capable of will be apparent and elucidated from the following description of embodiments of the present invention, reference being made to the accompanying drawings, in which

50 Fig. 1 is a diagram showing a chemical transformation of a light absorbing compound.

Fig. 2 is a diagram showing a chemical transformation of a light absorbing compound.

55 Fig. 3 is a graph showing percent transmittance of different media containing various concentrations of a light absorbing compound according to certain embodiments of the present invention.

Fig. 4 is a partial cross-sectional view of an optical article according to certain embodiments of the present invention.

Fig. 5 is a partial cross-sectional view of an optical article according to certain embodiments of the present invention.

Fig. 6 is a partial cross-sectional view of an optical article according to certain embodiments of the present invention.

Fig. 7 is a partial cross-sectional view of an optical article according to certain embodiments of the present invention.

5 Fig. 8 is a partial cross-sectional view of an optical article according to certain embodiments of the present invention.

Fig. 9 is a partial cross-sectional view of an optical article according to certain embodiments of the present invention.

10 Fig. 10 is a graph showing percent transmittance of laminates containing various concentrations of a light absorbing compound according to certain embodiments of the present invention.

Fig. 11 is a graph showing percent transmittance of laminates containing various concentrations of light absorbing compounds according to certain embodiments of the present invention.

15 Fig. 12 is a graph showing percent transmittance of laminates containing various concentrations of light absorbing compounds according to certain embodiments of the present invention.

20 Fig. 13 is a graph showing percent transmittance of light for laminates containing a light absorbing compound and for lenses employing the same according to certain embodiments of the present invention.

Fig. 14 is a table showing certain optical characteristics of laminates containing a light absorbing compound and for lenses employing the same according to certain embodiments of the present invention.

25 Fig. 15 is a partial cross-sectional view of an optical article according to certain embodiments of the present invention.

Fig. 16 is a partial cross-sectional view of an optical article according to certain embodiments of the present invention.

DESCRIPTION OF EMBODIMENTS

30 **[0019]** Specific embodiments of the invention will now be described with reference to the accompanying drawings. This invention may, however, be embodied in many different forms and should not be construed as limited to the embodiments set forth herein; rather, these embodiments are provided so that this disclosure will be thorough and complete, and will fully convey the scope of the invention to those skilled in the art. The terminology used in the detailed description of the embodiments illustrated in the accompanying drawings is not intended to be limiting of the invention.
35 In the drawings, like numbers refer to like elements.

[0020] Generally speaking, the present invention relates to eye health and protection of the human eye through absorbance of harmful ultraviolet (UV) and/or high energy visible (HEV, i.e. blue) light by additives present in the lens materials of construction, including as components within an adhesive layer in a laminate contained within a composite lens, as components within a monolithic sheet used by itself or as part of a laminate or non-laminate structure within a composite lens, added to thermoplastic pellets from which lenses are molded, or added to a curable composition, for example, a thermoset liquid or UV cured monomer compositions or a curable polyurethane based composition, from which lenses are cast. The present invention further relates to light absorbing filters to block damaging photons, while maintaining a good cosmetic appearance with low levels of coloration (or yellowness).

40 **[0021]** In certain embodiments, light absorbing filters according to the present invention include an absorbing compound, or compounds employed in combination, of the first class of materials described above, i.e. materials subject to tautomerization in which a hydrogen atom transfers from an oxygen atom in a ground state to a neighbouring nitrogen atom in an excited state. For example, compounds which function by the hydrogen atom transfer mechanism include hydroxyphenyl benzotriazoles, exemplified by 2-(3'-tert-butyl-2'-hydroxy-5'-methylphenyl)-5-chlorobenzotriazole (CAS #: 3896-11-5), available commercially as Tinuvin 326 or Omnistab 326; or pyrrolo[3,4-f]benzotriazole-5,7(2H,6H)-dione, 6-butyl-2-[2-hydroxy-3-(1-methyl-1-phenylethyl)-5-(1,1,3,3-tetramethylbutyl)phenyl]- (CAS# 945857-19-2) available commercially as Tinuvin CarboProtect; hydroxyphenyl triazines exemplified by 2-(4,6-diphenyl-1,3,5-triazin-2-yl)-5-[(hexyl)oxy]-phenol, (CAS# 147315-50-2) available commercially as Tinuvin 1577; or the mixture of 2-[4-[2-hydroxy-3-tridecyl (and dodecyl) oxypropyl]oxy]-2-hydroxyphenyl]-4,6-bis(2,4-dimethylphenyl)-1,3,5-triazine (CAS# 153519-44-9) available commercially as Tinuvin 400; and hydroxybenzophenones exemplified by 2-hydroxy-4-octyloxybenzophenone (CAS# 1843-05-6) available commercially as Uvinul 3008; or 2,2'-dihydroxy-4,4'-dimethoxy benzophenone (CAS# 131-54-4) available commercially as Uvinul D49 and Cyasorb UV.

55 **[0022]** In certain embodiments, light absorbing filters according to the present invention include an absorbing compound, or compounds employed in combination, of the second class of materials described above, i.e. materials subject

to the breaking of a double bond to form two adjacent stabilized radicals. Two principle examples of materials of this second class that function by formation of two adjacent stabilized free radical centers from a carbon to carbon double bond allowing the resultant single bond to dissipate energy through rotation, known as diaryl cyanoacrylates include ethyl-2-cyano-3,3-diphenylacrylate (CAS# 5232-99-5) commercially available as Uvinul 3035; and 1,3-bis-[(2'-cyano-3',3'-diphenylacryloyl)oxy]-2,2-bis-[[[(2'-cyano-3',3'-diphenylacryloyl)oxy]methyl]-propane (CAS# 178671-58-4) commercially available as Uvinul 3030. This second class of materials tends to absorb shorter wavelength (higher energy) light than the first class of hydrogen atom transfer light absorbers.

[0023] The UV/visible spectrum used to characterize the absorbing properties of molecules is acquired at a fixed path length (1 or 10 mm) and at low molar concentrations (in the range of 10^{-4} to 10^{-6} moles/liter, depending on the molar extinction coefficient) of the absorber dissolved in a solvent that is transparent in the wavelength region of interest. For organic absorbers of the present invention, the solvent employed is, for example but not limited to, an alcohol (e.g. ethanol), an ether (e.g. tetrahydrofuran), a glycol ether (e.g. propylene glycol monomethyl ether), or a hydrocarbon (e.g. cyclohexane) solvent.

[0024] It has been determined that while the efficacy of light absorbance principally depends on an absorber's molecular structure, the efficacy of light absorbance also strongly relates (1) to the absorber's concentration in the medium in which it is dissolved or dispersed and (2) to the light path length through which it is expected to operate. For example, with respect to a given structure, a longer light path length (at a fixed concentration) results in a lower percentage of transmitted incident light. Analogously, a higher concentration of absorber (at a fixed path length) also results in a lower percentage of transmitted incident light. This behavior falls into two regimes, a linear relationship at low concentrations and/or short path lengths, and a nonlinear relationship at high concentrations and/or long path lengths (Beer-Lambert Law; more absorber or a longer path results in lower light transmittance but additional amounts or increased path lengths absorb less than predicted by the line generated at low concentration or short path lengths).

[0025] Accordingly, in certain embodiments of the present invention, depending on the technical or commercial application and amount of incident light and wavelength region desired to be removed (filtered out), the concentration of the absorber employed is optimized. For example, in a (transparent) coating (generally limited to less than or equal to 10 microns thick), where the path length is very short, a higher concentration of absorber is required to remove the same amount of incident light than is required for a transparent body of macroscopic thickness (millimeters). It has been found that this concentration is difficult to predict because of the nonlinearity of the absorbing behavior.

[0026] This is shown in Fig. 3 which provides a comparison of the behaviour of different concentrations of absorber in GEPM solution, propylene glycol monomethyl ether, having a 1 mm light path to different concentrations of absorber behaviour in a polyurethane laminating adhesive having a 41 μm path. The absorber in GEPM solution results were adjusted to simulate a polycarbonate film in the laminate structure. In other words, the concentration of the absorber in the GEPM solution was adjusted up or down as required by the different absorbers' molar extinction coefficients to absorb the target amount of light below the target cut-off wavelength in the 1 mm path length to observe their spectra and permit estimation of the amount of absorber required in the application.

[0027] The laminate samples shown in Fig. 3 were formed of a standard commercial solvent-borne two-part polyurethane formulation into which absorber was added at levels estimated from their solution behaviour at much longer path lengths prior to casting and lamination. The adhesive layer was approximately 41 micrometres in thickness and was supported by polycarbonate film.

[0028] As shown in Fig. 3, the absorbance is so strong that as the concentration of the absorber increases, the lower, left shoulder of transmittance shifts farther into the HEV wavelengths, i.e. as concentrations of the absorber increase, so does absorbance of HEV wavelengths. Consequently, in certain embodiments, the effective amounts of the light absorbers employed depends on the manner of application of the absorber within the lens e.g. application as a microns thick laminating adhesive or coating layer, as a fractional millimeter thick monolithic film forming one part of a laminate structure, or as the multi-millimeter thick bulk lens molding material.

[0029] The transmittance shift into the HEV wavelengths is significant because, in certain applications of the present invention, the objective is to achieve a lens with maximum transmission and minimum residual color in transmission while also achieving a degree of UV and HEV light blocking. In certain embodiments, the transmittance should be as close as possible to the resin without the introduction of the absorber, for example, approximately less than 80 percent. However, exact values depend upon the thickness of material and are often approximately less than 90 percent for ophthalmic lenses. A residual color of the ophthalmic article can be expressed by color coordinates (x,y,Y or $L^*a^*b^*$) but, in view of the above objectives, it can be more meaningful to evaluate the optical articles of the present invention in terms of the transmitted yellow index of the lens (YI [1925 C/2]).

[0030] The effect of the absorber is to selectively remove portions of the UV and blue spectrum. A consequence of doing this is to increase the appearance of yellow in the lens color. Yellow color is often associated with aging or degradation of objects and is therefore found to be aesthetically displeasing. Hence, in certain embodiments, optical articles according to the present invention have yellow indices of preferably less than 3 but no more than 16. At values below 3, the yellow will not be noticed by most observers. In contrast, values above 16 will be found objectionable by

most observers. The acceptance between 3 and 16 will depend on the application and viewing conditions.

[0031] The broad range of light absorber structures useful in this invention have different characteristic molar extinction coefficients (a measure of their light absorbing efficiencies). Hence, specification of a generically useful absorber amount by weight percent of composition may seem substantially high in some cases. In certain embodiments, selection of an absorber and the absorber's appropriateness in a given location (related to path length and amount required to absorb the desired amount of light) is optimized. Therefore, the relative phrase "amount sufficient to provide the desired effect" may be more suitable in some cases. For example, the terms λ_{50} , λ_{10} , λ_5 and λ_1 , defined as the wavelength at which transmittance is 50, 10, 5, and 1 percent, respectively, of the incident light at the stated wavelength, can be more useful. Table 1 below numerically expresses certain of the data employed to generate the graph of Fig. 3 according to this scheme (to the nearest whole nm).

Table 1

Tinuvin CarboProtect GEPM Solutions; 1.0mm Path Length				Tinuvin CarboProtect PU Laminates; 41 μ m Path Length			
λ , (nm)	0.1wt%	0.2wt%	0.4wt%	λ (nm)	1.0wt%	2.0wt%	4.0wt%
λ_{50}	422	428	433	λ_{50}	419	425	431
λ_{10}	408	416	423	λ_{10}	397	411	419
λ_5	403	413	420	λ_5	385	407	415
λ_1	392	407	416	λ_1	n/a	396	410

[0032] In certain embodiments, as shown in Fig. 4, a light-absorbing laminate or monolithic film 10 according to the present invention is placed into a mold cavity and a composite lens 12 is formed via injection molding of a molten thermoplastic resin 14 into the mold cavity containing the light-absorbing laminate or monolithic sheet. Detailed descriptions of exemplary injection molding processes are provided in the U.S. Pat. Nos. 5,757,459; 5,856,860; 5,827,614; 6,328,446; 6,814,896; 7,048,997; and 8,029,705, which are hereby incorporated herein by reference in their entireties.

[0033] In another embodiment, as shown in Fig. 5, a light-absorbing laminate or monolithic film 10 according to the present invention is placed into a mold cavity and a composite lens 18 is formed via casting, wherein the mold cavity containing the laminate or monolithic film is filled with a curable composition 16, for example a composition employing a liquid monomer mixture or a urethane based prepolymer composition (e.g. Trivex, PPG; CAS# 97-23-4), followed by curing of the composition to produce the composite lens 12. Detailed descriptions of exemplary casting processes are provided in the U.S. Pat. Nos. 7,858,001 and 8,367,211, which are hereby incorporated herein by reference in their entireties.

[0034] In another embodiment of the present invention, a light-absorbing compound(s) is added to, mixed with, or otherwise combined with thermoplastic pellets used for injection molding a lens 20 (Fig. 6) or a portion of a curable composition 22, for example a composition employing a liquid monomer mixture or a urethane based prepolymer composition (e.g. Trivex, PPG) used for casting a lens (Fig. 7).

[0035] In certain embodiments of the present invention, as shown in Fig. 8, light absorbing material or materials or compounds are added to, mixed with, or otherwise combined with a liquid applied hard coating 26 that is applied to the molded or cast lens 24.

[0036] In certain embodiments of the present invention, as shown in Fig. 9, a light-absorbing compound(s) is added to, mixed with, or otherwise combined with a carrier composition, e.g. a polyurethane adhesive carrier, that is employed to form a light absorbing layer 30 and the light absorbing layer 30 is laminated between to transparent monolithic films 32, e.g. between two polycarbonate films, to form a light absorbing laminate 34.

[0037] There are no limitations placed on the number of absorbers that can be used together, nor their locations when used in combination in composite lenses. Thus, different absorbing materials may be added to the adhesive in a laminate and the lens body material, analogous to Figure 4 for injection molded composite lenses (and correspondingly for cast composite lenses as shown in Figure 5). Likewise, the laminate may contain different absorbing materials in the adhesive and in the films laminated together, as well as in the body of the composite lens formed by injection molding or casting.

[0038] In certain embodiments of the present invention, an UV/HEV activated (photochromic) dye or dyes are employed in a photochromic adhesive layer 40 within a laminate 42 and one or more UV/HEV light absorbers is employed in a monolithic film 44 of the laminate structure on a side 46 opposite from the incident light, adjacent to the body of the lens, closest to the observer's eye behind the lens or ophthalmic article. Fig. 15 shows a composite lens 12 formed of such a photochromic, light-absorbing laminate 42 via injection molding of a molten thermoplastic resin 14 into the mold cavity containing the light-absorbing laminate 42. Fig. 16 shows a composite lens 18 formed of a photochromic, light-absorbing

laminates 42 via casting, wherein the mold cavity containing the laminates 42 is filled with a curable composition 16, for example a composition employing a liquid monomer mixture or a urethane based prepolymer composition (e.g. Trivex, PPG; CAS# 97-23-4), followed by curing of the composition to produce the composite lens 18.

5 [0039] In certain embodiments, an ophthalmic lens according to the present invention absorbs up to 99.9% of all light at wavelengths less than 440 nm.

[0040] In certain embodiments, an ophthalmic lens according to the present invention absorbs up to 99.9% of all light at wavelengths less than 420 nm.

[0041] In certain embodiments, an ophthalmic lens according to the present invention absorbs up to 99.9% of all light at wavelengths less than 400 nm.

10 [0042] In certain embodiments, an ophthalmic lens according to the present invention absorbs up to 99.9% of all light at wavelengths less than 440, 420, or 400 nm. The light is absorbed by additives present in a component of the lens construction, including (1) as a component within an adhesive layer in a laminate contained within a composite lens; (2) as a component within a monolithic sheet or film employed by itself or alone within a composite lens; (3) as a component within a monolithic sheet or film employed as part of a laminate structure contained within a composite lens; (4) as a component added to thermoplastic pellets from which lenses are molded; and/or (5) as a component added to thermoset or curable compositions, for example a composition employing a liquid monomer mixture or a urethane based prepolymer composition (e.g. Trivex, PPG) from which lenses are cast. Detailed descriptions of adhesive layers in laminates are provided in the U.S. Pat. Nos. 8,906,183; 8,298,671; 9,163,108; 9,081,130; and 9,440,019, which are hereby incorporated herein by reference in their entireties.

20 [0043] In certain embodiments, a laminate or a monolithic film according to the present invention absorbs up to 99.9% of all light at wavelengths less than 440, 420, or 400 nm, and the inventive light-absorbing laminate or monolithic film is placed into a mold cavity and a composite lens is formed through injection molding of a molten thermoplastic resin into the mold cavity containing the light-absorbing laminate or monolithic film.

25 [0044] In certain embodiments, a laminate or monolithic film according to the present invention absorbs up to 99.9% of all light at wavelengths less than 440, 420, or 400 nm, and the inventive light-absorbing laminate or the monolithic film is placed into a mold cavity and a composite lens is formed through casting wherein the mold cavity containing the laminate or monolithic film is filled with a curable composition, for example a composition employing a liquid monomer mixture or a urethane based prepolymer composition (e.g. Trivex, PPG), followed by curing of the curable composition to produce the composite lens.

30 [0045] In certain embodiments, an ophthalmic lens according to the present invention absorbs up to 99.9% of all light at wavelengths less than 440, 420, or 400 nm, wherein the thermoplastic pellets used for injection molding or the liquid thermoset or curable composition, for example a composition employing a liquid monomer mixture or a urethane based prepolymer composition (e.g. Trivex, PPG), used for casting the lenses contains the light-absorbing compounds.

35 [0046] In certain embodiments of the present invention the light absorbing material or materials employed to form any of the above-described light-absorbing laminate, monolithic film, and/or ophthalmic lens are absorbers which reversibly transfer hydrogen atoms or protons in the excited state to a neighboring heteroatom.

[0047] In certain embodiments of the present invention the light absorbing material or materials employed to form any of the above-described light-absorbing laminate, monolithic film, and/or ophthalmic lens are absorbers which reversibly transfer hydrogen atoms or protons in the excited state to a neighboring heteroatom wherein the hydrogen atom or proton is transferred to oxygen or nitrogen.

40 [0048] In certain embodiments of the present invention the light absorbing material or materials employed to form any of the above-described light-absorbing laminate, monolithic film, and/or ophthalmic lens are absorbers used at a weight percent of up to one in a transparent material having an optical path length greater than 1 mm.

45 [0049] In certain embodiments of the present invention the light absorbing material or materials employed to form any of the above-described light-absorbing laminate, monolithic film, and/or ophthalmic lens are absorbers used at a weight percent of up to three in a transparent material having an optical path length in the range of 0.1 mm and 1 mm.

[0050] In certain embodiments of the present invention the light absorbing material or materials employed to form any of the above-described light-absorbing laminate, monolithic film, and/or ophthalmic lens are absorbers used at a weight percent of up to ten in a transparent material having an optical path length in the range of 0.01 mm and 0.1 mm.

50 [0051] In certain embodiments, the light-absorbing laminate, monolithic film, and/or ophthalmic lens of the present invention employ additional functional properties, including but not limited to, coloration, tinting, hard coating, polarization, photochromism, electrochromism, UV absorption, narrow band filtering, easy-cleaning, hydrophobicity, and anti-static. Such functional properties are imparted through a coating or surface treatment of the inventive light absorbing laminate or monolithic film employed alone or as structure contained within a composite lens and/or ophthalmic lens. Alternatively, such functional properties are imparted as a component within an adhesive or protective layer of the laminate; as a component within the monolithic sheet or film; as a component added to thermoplastic pellets from which lenses are molded; and/or as a component added to curable compositions, for example a composition employing a liquid monomer mixture or a urethane based prepolymer composition (e.g. Trivex, PPG), from which lenses are cast.

[0052] As used herein, the term curable composition or compositions includes, but is not limited to, compositions curable through application of thermal energy, UV radiation, electron beam, x-ray, gamma-ray, microwave, and/or radio frequency.

[0053] In certain embodiments of the present invention, a combination of one or more of the above-described embodiments is employed to absorb an amount of light desired in a spectral region required to meet lens performance specifications.

EXAMPLES

[0054] General Procedure: A two-part solvent-borne polyurethane laminating adhesive was prepared from solutions comprising an isocyanate prepolymer, a polyol, a crosslinker and one or more absorbers at various concentrations. The absorbing adhesive solutions were cast onto a release liner at a wet film thickness sufficient to produce a 41 micrometre, plus or minus 2 micrometres, dry adhesive layer and dried for a time and temperature sufficient to remove the volatile solvent (tetrahydrofuran, THF) to less than or equal to 100 mg/m². The dried adhesive layer was transferred to a first polycarbonate optical film and then laminated to a second polycarbonate optical film to make a three-layer laminate structure. The laminates' absorbing characteristics were observed using a UV-vis spectrophotometer (Hunter, Agilent or Perkin-Elmer). Some of the laminates were used to fabricate composite lenses by injection molding using thermoplastic polycarbonate resin pellets.

Example 1:

[0055] Tinuvin 326 (BASF) was dissolved in THF and added to the two-part solvent borne polyurethane adhesive solution in amounts sufficient to produce adhesive solutions containing a weight percent of 6, 7, and 8, based on final dried adhesive solids, cast onto release liners, dried, and laminated to produce the experimental laminates. Portions of these laminates were placed into a UV-vis spectrophotometer for spectral characterization, as shown in Fig. 10 and summarized below in Table 2.

Table 2.

Tinuvin 326; 41µm Laminates			
λ (nm)	6%	7%	8%
λ₅₀	410	411	412
λ₁₀	401	402	403
λ₅	399	400	401
λ₁	395	397	398

Example 2:

[0056] Similar to Example 1, THF solutions containing both Tinuvin 326 and Tinuvin CarboProtect (BASF) were added to the two-part adhesive to provide the absorbers in the amounts indicated based on the dried adhesive solids, which adhesive solutions were cast onto release liners, dried, and laminated to produce experimental laminates with a dried adhesive layer of 41 micrometres. Portions of these laminates were placed into a UV-vis spectrophotometer for spectral characterization, as shown in Fig. 11 and summarized below in Table 3.

Table 3.

5% Tinuvin 326+CarboProtect; 41µm Laminates				
λ (nm)	0.1wt%	0.2wt%	0.3wt%	0.4wt %
λ₅₀	410	412	413	414
λ₁₀	401	402	402	403
λ₅	399	399	400	400
λ₁	395	395	396	396

Example 3:

[0057] Similar to Example 1, THF solutions containing Tinuvin CarboProtect ("TCBP"; BASF), Eusorb 390 ("UV390"; a proprietary heterocyclic styrene derivative, Eutec) or Eusorb 1990 ("UV1990"; a proprietary acrylic ester derivative, Eutec) were added to the two-part adhesive to provide all the absorbers at a weight percent of 2, based on the dried adhesive solids. These adhesive solutions were cast onto release liners, dried, and laminated to produce experimental laminates with a dried adhesive layer of 41 micrometers. Portions of these laminates were placed into a UV-vis spectrophotometer for spectral characterization, as shown in Fig. 12 and summarized below in Table 4.

Table 4.

Different Absorbers, 41 μm Laminates			
λ (nm)	UV390	UV1990	TCBP
λ ₅₀	443	434	426
λ ₁₀	434	423	412
λ ₅	432	420	408
λ ₁	427	415	398

Example 4:

[0058] Similar to Example 1, a THF solution containing Tinuvin 326 (BASF) was added to the two-part adhesive to provide the absorber at a weight percent of 6, based on the dried adhesive solids. The adhesive solution was cast onto release liners, dried, and laminated to produce experimental laminates with a dried adhesive layer of 41 micrometers. Wafers were punched from some of the laminates, which were placed into molds and fabricated as composite lenses. Laminates and lenses were characterized by UV-vis spectra, with the results shown in Figs. 13 and 14 and below in Table 5.

Table 5.

Averages of 14 Pieces		
λ (nm)	Laminate	Lens
λ ₅₀	410	410
λ ₁₀	401	402
λ ₅	399	400
λ ₁	395	397

[0059] Although the invention has been described in terms of particular embodiments and applications, one of ordinary skill in the art, in light of this teaching, can generate additional embodiments and modifications without departing from the spirit of or exceeding the scope of the claimed invention. Accordingly, it is to be understood that the drawings and descriptions herein are proffered by way of example to facilitate comprehension of the invention and should not be construed to limit the scope thereof.

Examples

[0060]

1. An ophthalmic article comprising:
a light absorbing layer having a weight percent of a light absorbing compound in the range of 0.1 to 10 and a transmittance of no more than 50 percent of light having wavelengths of up to 443 nm.
2. The ophthalmic article of example 1 wherein the light absorbing layer has a weight percent of a light absorbing compound of up to 3.

EP 4 365 644 A2

3. The ophthalmic article of example 1 wherein the light absorbing layer has a weight percent of a light absorbing compound of up to 1.
- 5 4. The ophthalmic article of example 1 wherein the light absorbing layer has a thickness of greater than 1 mm.
5. The ophthalmic article of example 1 wherein the light absorbing layer has a thickness in the range of 0.01 to 1 mm.
- 10 6. The ophthalmic article of example 1 wherein the light absorbing layer has a transmittance of no more than 50 percent of light having wavelengths of up to 410 nm.
7. The ophthalmic article of example 1 wherein the light absorbing layer is a monolithic film.
8. The ophthalmic article of example 1 wherein the light absorbing layer is an adhesive layer of a laminate.
- 15 9. The ophthalmic article of example 1 wherein the light absorbing layer is a component of a composite ophthalmic lens.
10. The ophthalmic article of example 1 wherein the light absorbing layer comprises a thermoplastic resin.
- 20 11. The ophthalmic article of example 1 wherein the light absorbing layer comprises a curable composition.
12. A method for forming an ophthalmic article comprising:
- 25 determining a target transmittance of light below a wavelength of 450 nm for the ophthalmic article;
- determining a target range of thickness of the ophthalmic article;
- adding a weight percent of a light absorbing compound to a medium based upon the target transmittance, the target range of thickness, and a target yellowness index for the ophthalmic article; and
- 30 forming the ophthalmic article with medium containing the light absorbing compound.
13. The method for forming an ophthalmic article of example 12 wherein the determining a target transmittance comprises determining a target transmittance of less than 50 percent.
- 35 14. The method for forming an ophthalmic article of example 12 wherein the determining a target transmittance comprises determining a transmittance of not more than 50 percent of light wavelengths of up to 410 nm.
15. The method for forming an ophthalmic article of example 12 wherein the determining a target range of thickness comprises determining a thickness of greater than 1 mm.
- 40 16. The method for forming an ophthalmic article of example 12 wherein the determining a target range of thickness comprises determining a thickness in the range of 0.01 to 1 mm.
- 45 17. The method for forming an ophthalmic article of example 12 wherein the adding a weight percent of a light absorbing compound to a medium comprises adding a weight percent of the light absorbing compound in the range of 0.1 to 10.
18. The method for forming an ophthalmic article of example 12 wherein the forming the ophthalmic article comprises forming the ophthalmic article through injection molding of a molten thermoplastic.
- 50 19. The method for forming an ophthalmic article of example 12 wherein the forming the ophthalmic article comprises forming the ophthalmic article through curing of a curable composition.
- 55 20. The method for forming an ophthalmic article of example 12 wherein the forming the ophthalmic article comprises forming a composite ophthalmic article having a layer of the medium containing the light absorbing compound.

Claims

1. A method of forming a light absorbing laminate of an eyeglass lens comprising:

5 forming an adhesive layer containing one or more light absorbers;
laminating a first optical film to a first side of said adhesive layer and a second optical film to a second side of
said adhesive layer to form a multi-layered structure of said light absorbing laminate,
placing said multi-layered structure of said light absorbing laminate into a mold to form an eyeglass lens and
thereby obtaining a relationship between a thickness of said light absorbing laminate and a weight percent of
10 said one or more light absorbers to achieve at least a transmittance value in a range of 1 to 50 percent for
wavelengths in a range of up to 443 nm for said light absorbing laminate.

2. The method of claim 1, wherein forming said adhesive layer containing one or more light absorbers further comprises:

15 forming a first solution by dissolving an isocyanate prepolymer, a polyol, a crosslinker in a solvent and adding
a second solution of one or more light absorbers in said solvent into said first solution to form a polyurethane
based adhesive solution containing one or more light absorbers;
casting said polyurethane based adhesive solution onto a release liner and thereby forming a wet film; and
drying said wet film for a specific time and at a specific temperature to remove said solvent and thus forming
20 said polyurethane based adhesive layer.

3. The method of any of claims 1 to 2, wherein said first optical film and said second optical film further comprises a polycarbonate optical film.

25 4. The method of any of claims 1 to 3, wherein obtaining said relationship between said thickness of said light absorbing
laminate and said weight percent of said one or more light absorbers comprises adding said weight percent in a
range of 0.1 to 0.4 of said one or more light absorbers and forming said thickness of 1.0 mm of said light absorbing
laminate.

30 5. The method of any of claims 1 to 4, wherein obtaining said relationship between said thickness of said light absorbing
laminate and said weight percent of said one or more light absorbers comprises adding said weight percent in a
range of 2-8 of said one or more light absorbers and forming said thicknesses of 0.041 mm of said light absorbing
laminate.

35 6. The method of claim 4, wherein obtaining said relationship between said thickness of said light absorbing laminate
and said weight percent of said one or more light absorbers comprises adding said weight percent of 0.1 of said
one or more light absorbers, forming said thickness of 1.0 mm of said light absorbing laminate, and obtaining the
transmittance value in the range of 1 to 50 percent in a range of 392 nm to 422 nm.

40 7. The method of claim 4, wherein obtaining said relationship between said thickness of said light absorbing laminate
and said weight percent of said one or more light absorbers comprises adding said weight percent of 0.2 of said
one or more light absorbers, forming said thickness of 1.0 mm of said light absorbing laminate, and obtaining the
transmittance value in the range of 1 to 50 percent in a range of 407 nm to 428 nm.

45 8. The method of claim 4, wherein obtaining said relationship between said thickness of said light absorbing laminate
and said weight percent of said one or more light absorbers comprises adding said weight percent of 0.4 of said
one or more light absorbers, forming said thickness of 1.0 mm of said light absorbing laminate, and obtaining the
transmittance value in the range of 1 to 50 percent in a range of 416 nm to 433 nm.

50 9. The method of claim 5, wherein obtaining said relationship between said thickness of said light absorbing laminate
and said weight percent of said one or more light absorbers comprises adding said weight percent of 2 of said one
or more light absorbers, forming said thickness of 0.041 mm of said light absorbing laminate, and obtaining the
transmittance value in the range of 1 to 50 percent in a range of 398 nm to 443 nm.

55 10. The method of claim 5, wherein obtaining said relationship between said thickness of said light absorbing laminate
and said weight percent of said one or more light absorbers comprises adding said weight percent of 6 of said one
or more light absorbers, forming said thickness of 0.041 mm of said light absorbing laminate, and obtaining the
transmittance value in the range of 1 to 50 percent in a range of 395 nm to 410 nm.

5
11. The method of claim 5, wherein obtaining said relationship between said thickness of said light absorbing laminate and said weight percent of said one or more light absorbers comprises adding said weight percent of 7 of said one or more light absorbers, forming said thickness of 0.041 mm of said light absorbing laminate, and obtaining the transmittance value in the range of 1 to 50 percent in a range of 397 nm to 411 nm.

10
12. The method of claim 5, wherein obtaining said relationship between said thickness of said light absorbing laminate and said weight percent of said one or more light absorbers comprises adding said weight percent of 8 of said one or more light absorbers, forming said thickness of 0.041 mm of said light absorbing laminate, and obtaining the transmittance value in the range of 1 to 50 percent in a range of 398 nm to 412 nm.

15
13. The method of claim 2, wherein drying said wet film further comprises removing said solvent to less than or equal to 100 mg/m².

20
14. The method of claim 13, wherein drying said wet film further comprises removing tetrahydrofuran to less than or equal to 100 mg/m².

25
30
35
40
45
50
55
15. The method for forming an eyeglass lens of any of claims 1 to 14, wherein said forming of said eyeglass lens comprises forming said eyeglass lens through injection molding of a molten thermoplastic.

Fig. 1

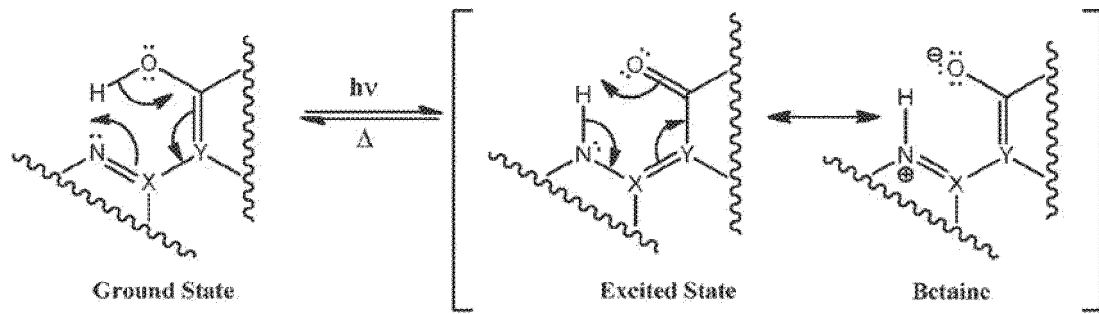

Fig. 2

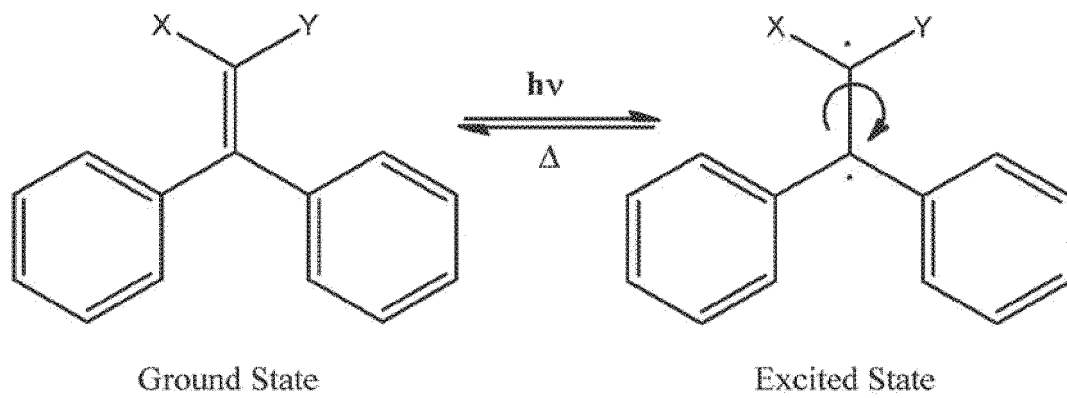

Fig. 3

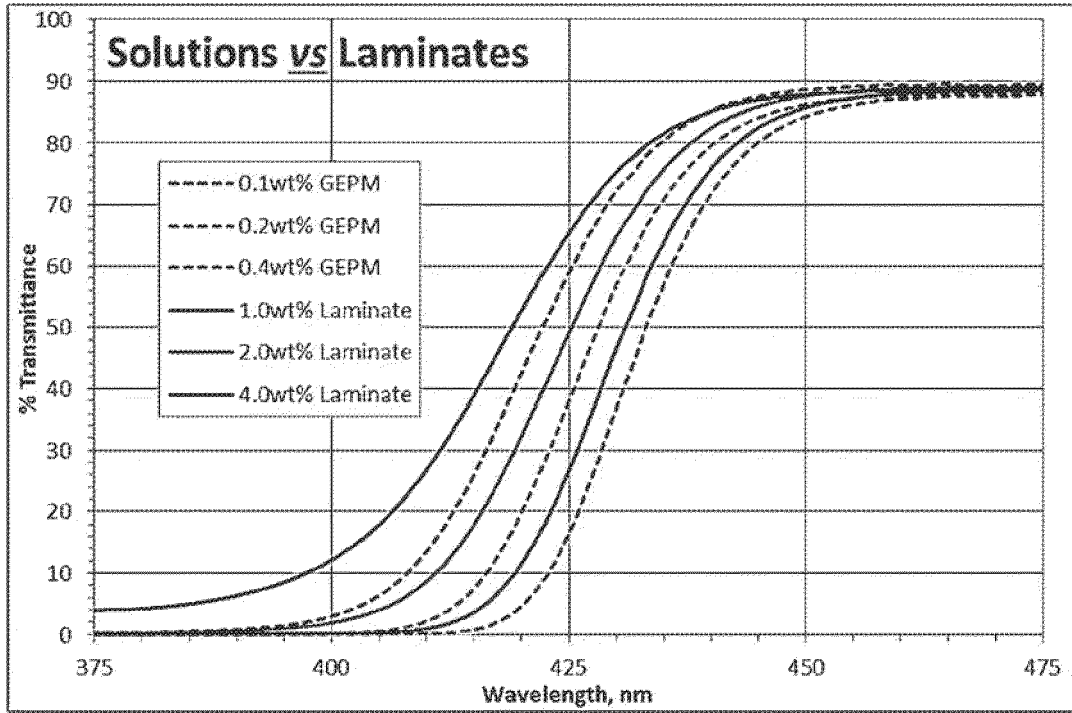

Fig. 4

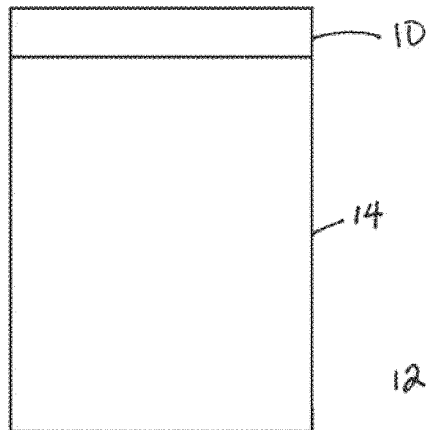

Fig. 5

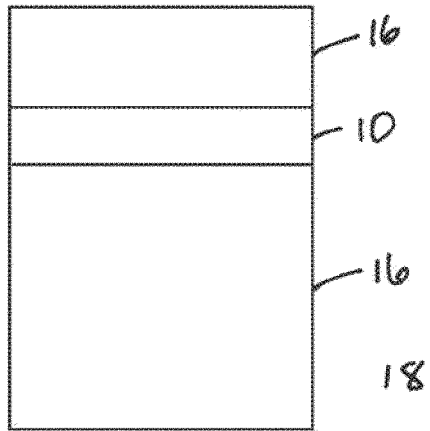

Fig. 6

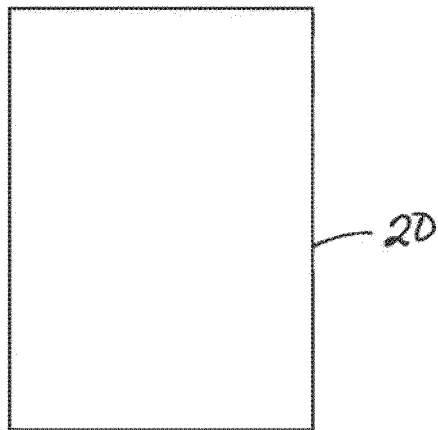

Fig. 7

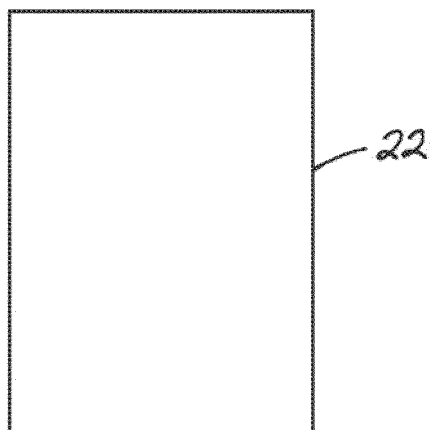

Fig. 8

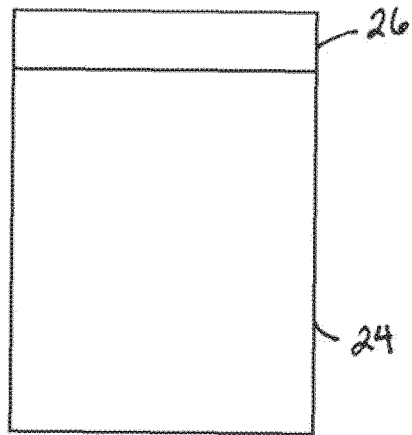

Fig. 9

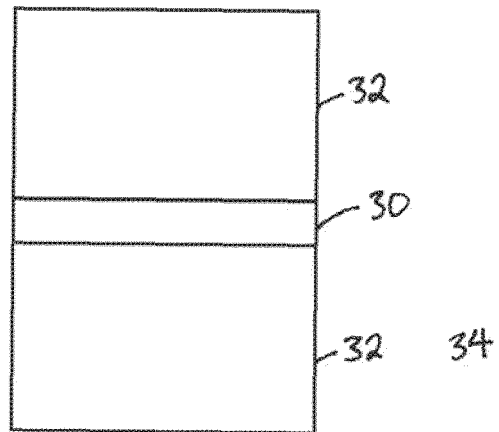

Fig. 10

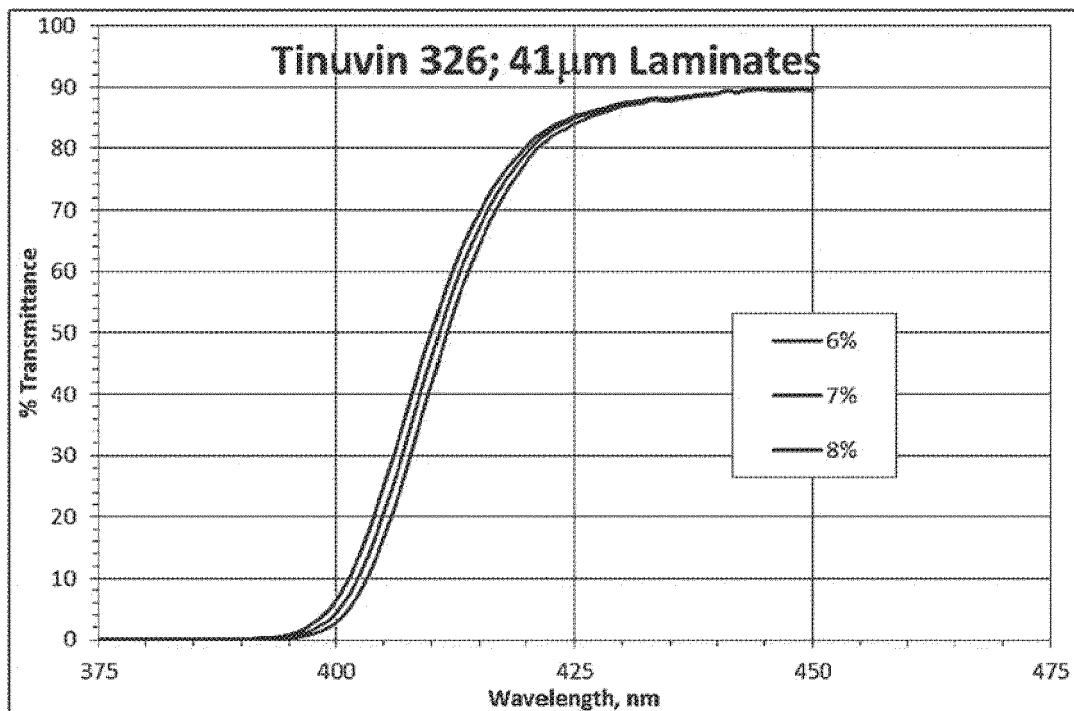

Fig. 11

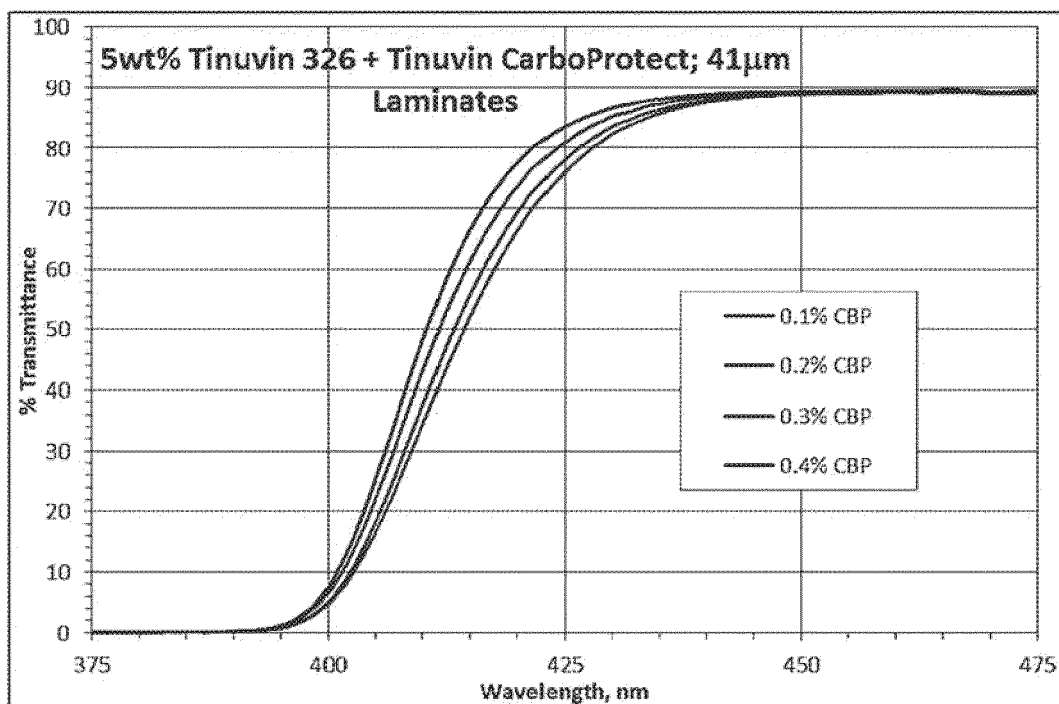

Fig. 12

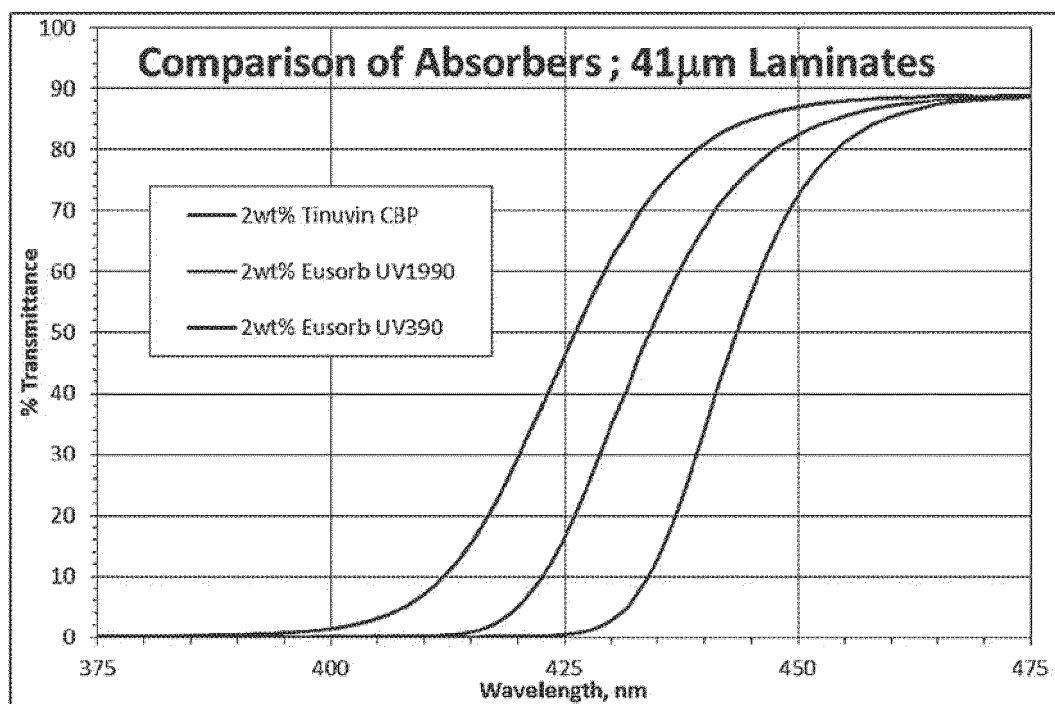

Fig. 13

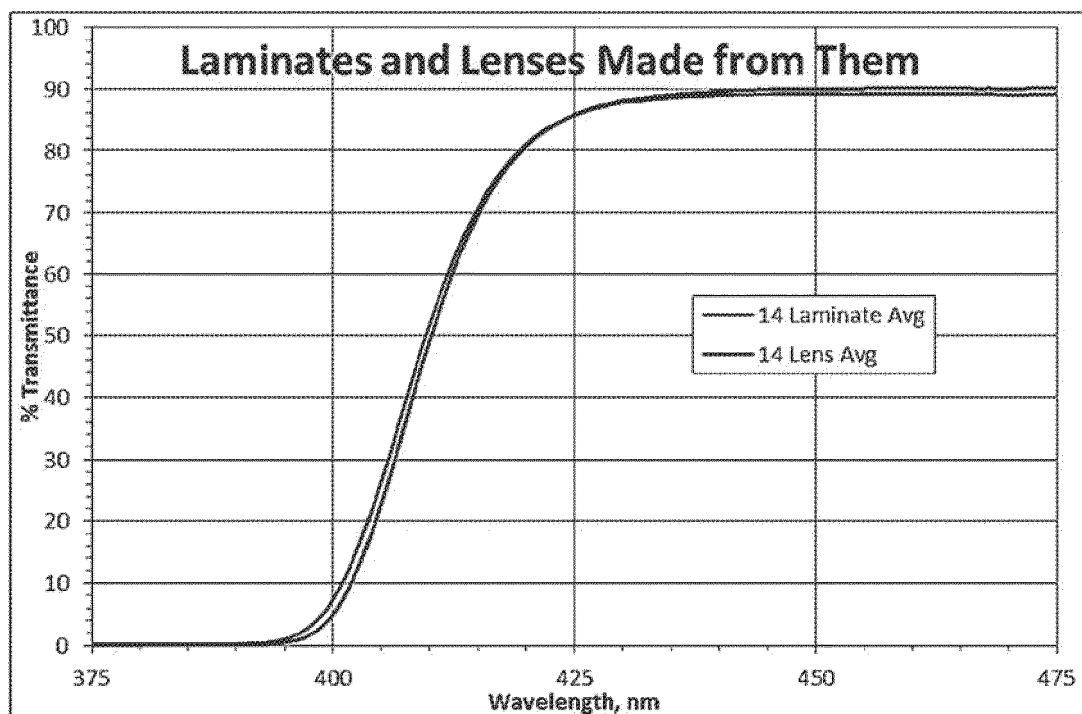

Fig. 14

λ , nm	UVB %T		UVA %T		HEV %T		AS/NZS 1067:2003		% T ₄₀₀		Blue Light %T		BLB		EPF		Luminous		L*			a*			b*			YI			Chromaticity Coordinates		
	280-315	315-400	380-500	280-400	400	400-500	100/BL %T	380-500	380-780	2*/ASTM D65			D1925			D65 X			D65 Y														
Wafers	0.01	0.01	67.13	Pass	7.23	85.61	1.17	1.17	89.75	95.83	-0.36	1.52	2.58	0.315	0.332																		
Lenses	0.02	0.01	65.28	Pass	1.60	84.79	1.18	1.18	90.06	96.01	-0.92	1.74	2.50	0.315	0.333																		

Fig. 15

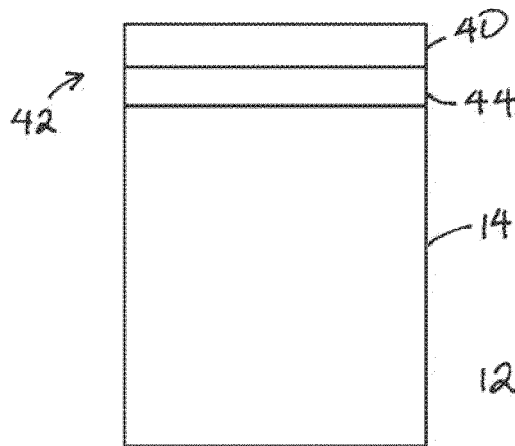
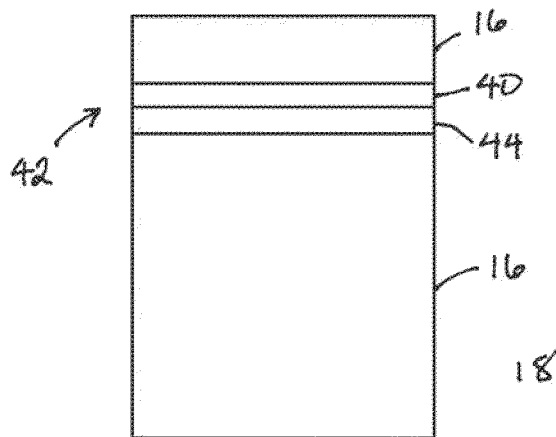

Fig. 16



REFERENCES CITED IN THE DESCRIPTION

This list of references cited by the applicant is for the reader's convenience only. It does not form part of the European patent document. Even though great care has been taken in compiling the references, errors or omissions cannot be excluded and the EPO disclaims all liability in this regard.

Patent documents cited in the description

- US 62234543 [0001]
- US 5757459 A [0032]
- US 5856860 A [0032]
- US 5827614 A [0032]
- US 6328446 B [0032]
- US 6814896 B [0032]
- US 7048997 B [0032]
- US 8029705 B [0032]
- US 7858001 B [0033]
- US 8367211 B [0033]
- US 8906183 B [0042]
- US 8298671 B [0042]
- US 9163108 B [0042]
- US 9081130 B [0042]
- US 9440019 B [0042]

Non-patent literature cited in the description

- CHEMICAL ABSTRACTS, 3896-11-5 [0021]
- CHEMICAL ABSTRACTS, 945857-19-2 [0021]
- CHEMICAL ABSTRACTS, 147315-50-2 [0021]
- CHEMICAL ABSTRACTS, 153519-44-9 [0021]
- CHEMICAL ABSTRACTS, 1843-05-6 [0021]
- CHEMICAL ABSTRACTS, 131-54-4 [0021]
- CHEMICAL ABSTRACTS, 5232-99-5 [0022]
- CHEMICAL ABSTRACTS, 178671-58-4 [0022]
- CHEMICAL ABSTRACTS, 97-23-4 [0033] [0038]