



US 20170312825A1

(19) **United States**

(12) **Patent Application Publication**
FANDREI, II

(10) **Pub. No.: US 2017/0312825 A1**

(43) **Pub. Date: Nov. 2, 2017**

(54) **NEAR-NET SHAPE SHIELD AND FABRICATION PROCESSES**

C23C 4/04 (2006.01)

C23C 4/00 (2006.01)

F01D 5/28 (2006.01)

(71) Applicant: **GENERAL ELECTRIC COMPANY**,
Schenectady, NY (US)

B23K 101/00 (2006.01)

B23K 103/02 (2006.01)

B23K 103/08 (2006.01)

(72) Inventor: **Theodore William FANDREI, II**,
Latham, NY (US)

B23K 103/18 (2006.01)

B23K 103/18 (2006.01)

(21) Appl. No.: **15/651,329**

(52) **U.S. Cl.**

CPC *B22F 7/06* (2013.01); *F01D 5/288*

(22) Filed: **Jul. 17, 2017**

(2013.01); *B23K 1/0018* (2013.01); *B23K*

9/167 (2013.01); *B23K 10/02* (2013.01); *B23K*

15/0046 (2013.01); *B23K 26/32* (2013.01);

B23P 15/04 (2013.01); *F01D 5/286* (2013.01);

F01D 5/28 (2013.01); *C23C 28/00* (2013.01);

C23C 24/08 (2013.01); *C23C 24/06* (2013.01);

C23C 24/02 (2013.01); *C23C 24/00* (2013.01);

C23C 6/00 (2013.01); *C23C 4/04* (2013.01);

C23C 4/00 (2013.01); *B23K 2201/001*

(2013.01); *B23K 2203/02* (2013.01); *B23K*

2203/08 (2013.01); *B23K 2203/18* (2013.01);

B22F 2998/10 (2013.01); *B23K 2203/26*

(2015.10); *F05D 2300/175* (2013.01)

Related U.S. Application Data

(62) Division of application No. 13/630,644, filed on Sep. 28, 2012, now Pat. No. 9,737,933.

Publication Classification

(51) **Int. Cl.**

B22F 7/06 (2006.01)

B23K 1/00 (2006.01)

B23K 9/167 (2006.01)

B23K 10/02 (2006.01)

B23K 15/00 (2006.01)

B23K 26/32 (2014.01)

B23P 15/04 (2006.01)

F01D 5/28 (2006.01)

F01D 5/28 (2006.01)

C23C 28/00 (2006.01)

C23C 24/08 (2006.01)

C23C 24/06 (2006.01)

C23C 24/02 (2006.01)

C23C 24/00 (2006.01)

C23C 6/00 (2006.01)

(57)

ABSTRACT

A process of fabricating a shield, a process of preparing a component, and an erosion shield are disclosed. The process of fabricating the shield includes forming a near-net shape shield. The near-net shape shield includes a nickel-based layer and an erosion-resistant alloy layer. The nickel-based layer is configured to facilitate secure attachment of the near-net shaped to a component. The process of preparing the component includes securing a near-net shape shield to a substrate of a component.

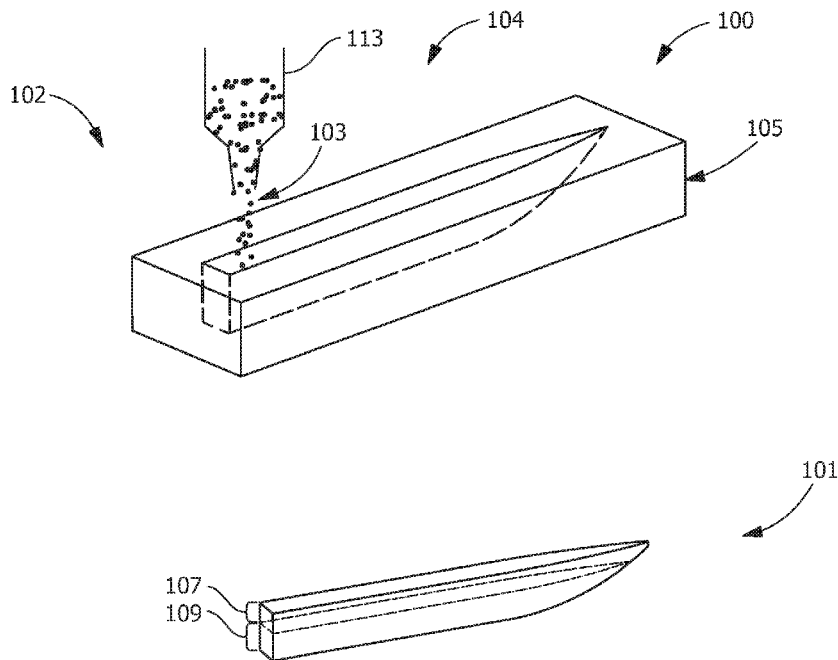

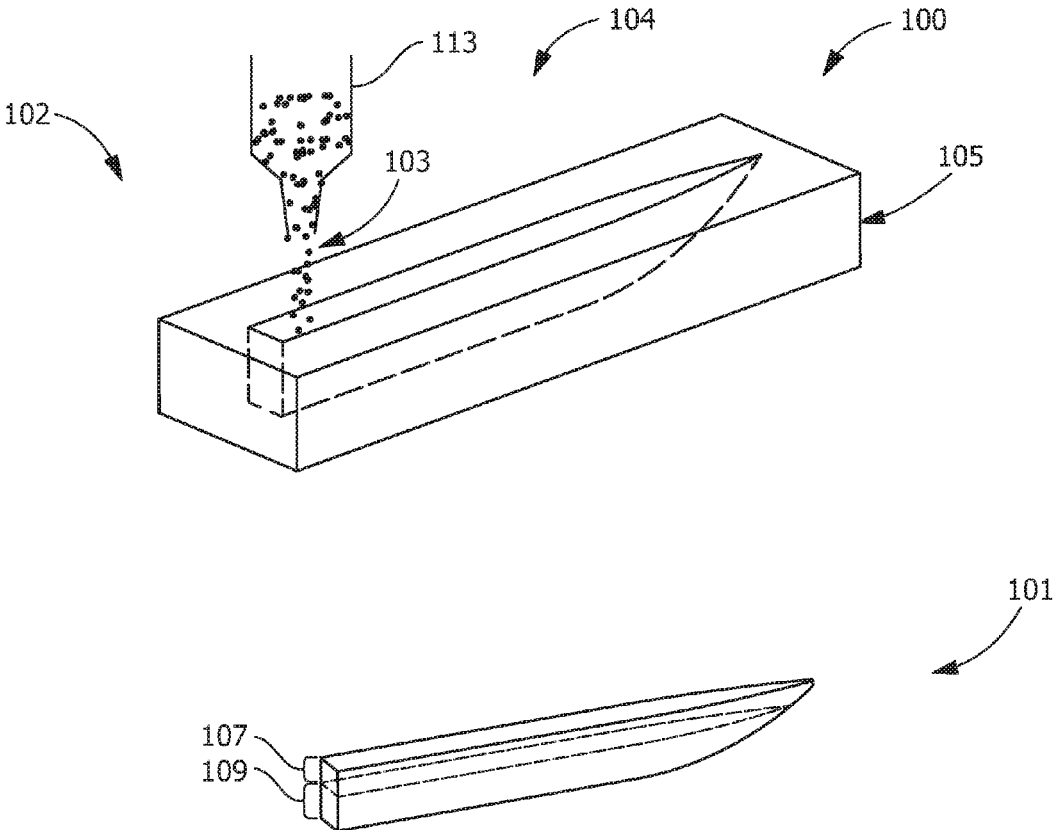

FIG. 1

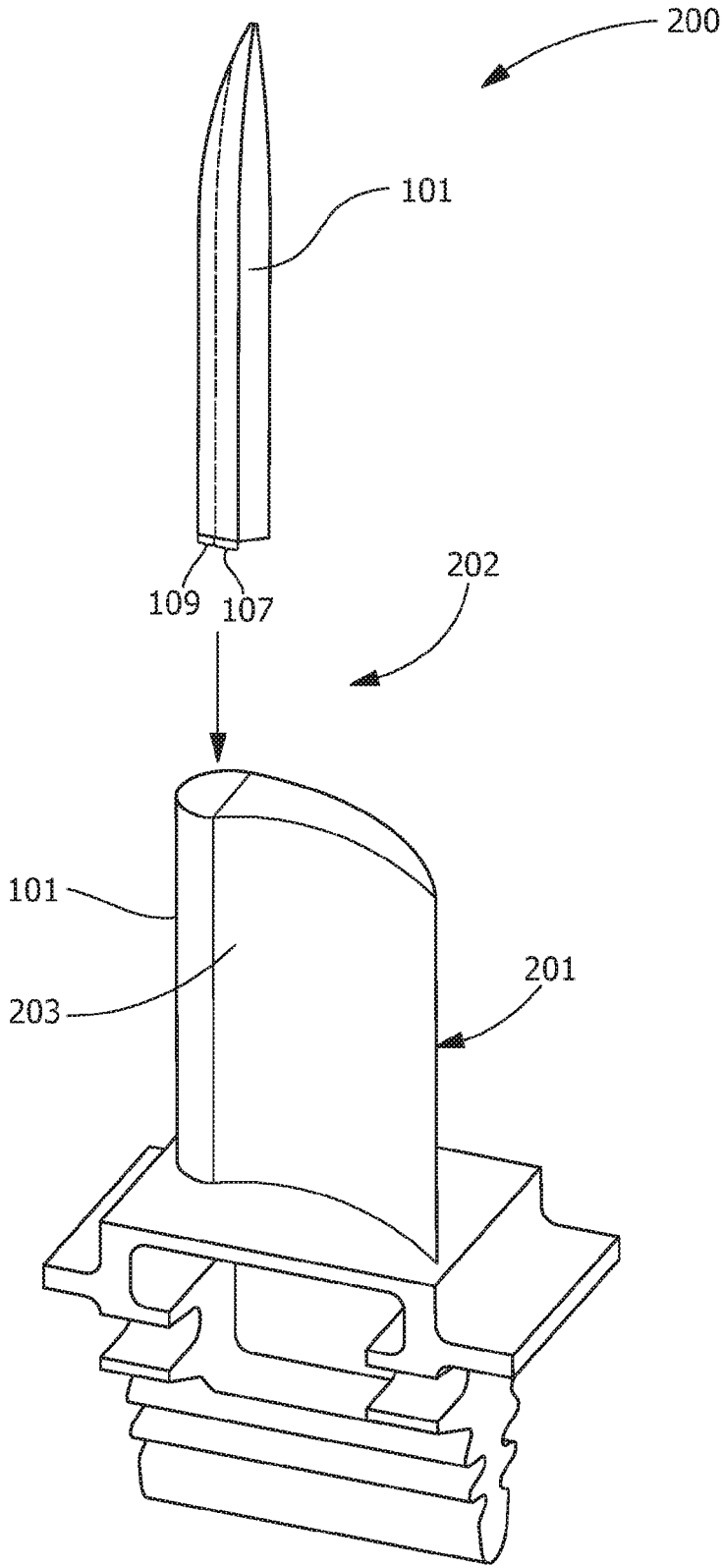

FIG. 2

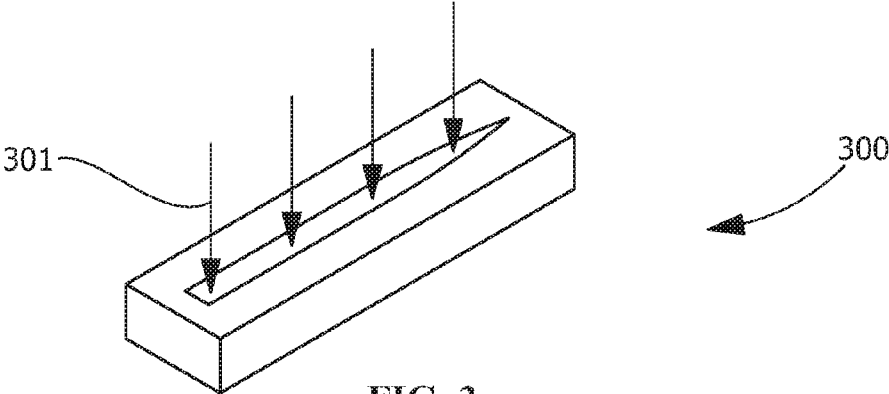

FIG. 3

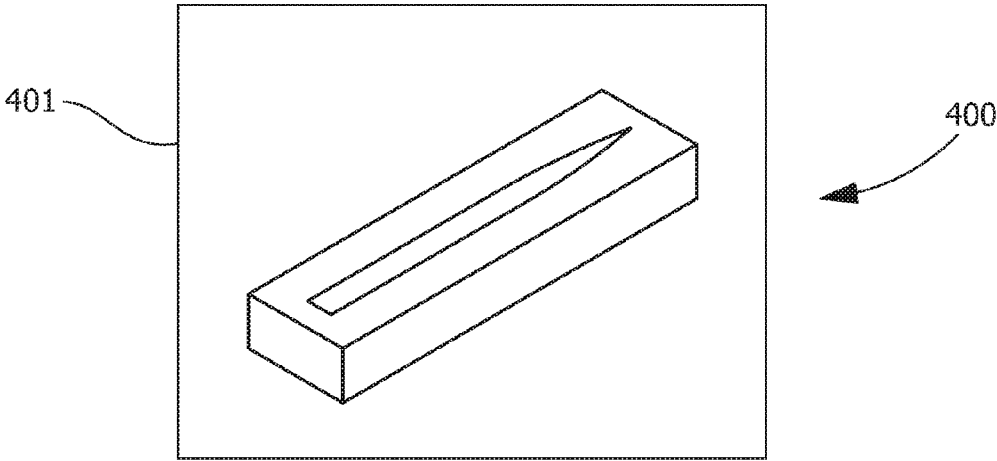

FIG. 4

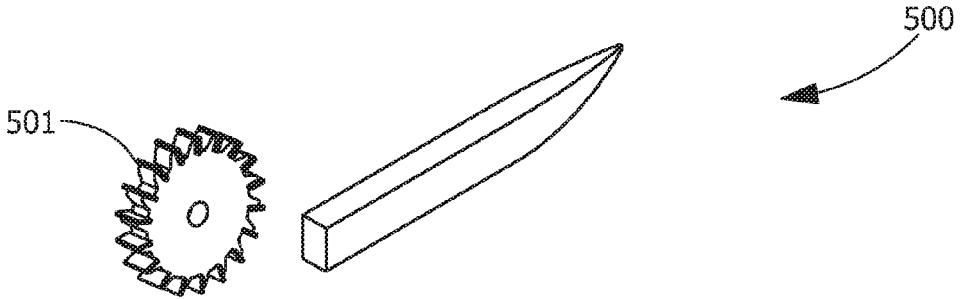

FIG. 5

NEAR-NET SHAPE SHIELD AND FABRICATION PROCESSES

CROSS-REFERENCE TO RELATED APPLICATIONS

[0001] This application is a divisional of U.S. Utility application Ser. No. 13/630,644, filed on Sep. 28, 2012, and entitled "PROCESS OF FABRICATING A SHIELD AND PROCESS OF PREPARING A COMPONENT", the disclosure of which is hereby incorporated by reference in its entirety.

FIELD OF THE INVENTION

[0002] The present invention is directed to processes of fabricating and preparing manufactured components and to manufactured components. More specifically, the present invention is directed to protection of iron-based and nickel-based substrates.

BACKGROUND OF THE INVENTION

[0003] Components in power generation systems, such as the turbine rotor blades and the turbine stator blades, are used in turbine equipment and can be exposed to an erosive environment, resulting in erosion caused by water droplets, for example, in steam and/or by fine dust from oxide scale. In particular, water droplets can cause erosion of rear-stage turbine blades, where such water droplets are mixed with the steam for turbine driving. Erosion of turbine blades is problematic because it results in blade thinning and fatigue breakdown of the blade brought about by erosion.

[0004] Various erosion preventative measures have been implemented to try to increase the durability of turbine components against erosion. One of these preventative measures involves methods that use low heat-input build-up welding with a high energy-density heat source, such as laser beams to build up a plurality of single layers on the turbine component.

[0005] Known build-up welding techniques take a significant amount of time to produce the desired erosion protection layer. Another problem with using such build-up techniques is that the erosion layer must also be machined after formation to the desired blade geometry, increasing processing steps and time in manufacturing, thereby increasing costs.

[0006] Some build-up welding techniques use STELLITE®, a cobalt-chromium alloy available from Deloro Stellite Holdings Corporation of Goshen, Ind. Use of STELLITE® can cause several undesirable features, such as, forming a complex carbon dilution layer, creating issues for welding operations, causing cracking under high-temperatures along build-up welded portions, creating a need for significant machining to get to a desired component size/geometry, or combinations thereof.

[0007] Another preventative measure is to use an erosion shield, for example, including STELLITE®. The erosion shield is secured to the turbine component and protects the component from erosion. Materials for such erosion shields are provided in wrought condition, requiring processing and/or machining to achieve desired sizes and/or geometries. Such processing and/or machining is especially expensive for complex shapes, such as turbine blades or airfoils.

[0008] A process of producing or fabricating a shield, a process of preparing a component, and an erosion shield that do not suffer from one or more of the above drawbacks would be desirable in the art.

BRIEF DESCRIPTION OF THE INVENTION

[0009] In an exemplary embodiment, a process of fabricating a shield includes forming a near-net shape shield. The near-net shape shield includes a nickel-based layer and an erosion-resistant alloy layer. The nickel-based layer is configured facilitate secure attachment of the near-net shaped to a component.

[0010] In another exemplary embodiment, a process of preparing a component includes securing a near-net shape shield to a substrate of a component. The near-net shape shield comprises a nickel-based layer and an erosion-resistant alloy layer positioned at least partially on the nickel-based layer.

[0011] In another exemplary embodiment, a near-net shape shield includes a nickel-based layer and an erosion-resistant alloy layer positioned at least partially on the nickel-base layer. The near-net shape shield is configured to be positioned on a turbine component.

[0012] Other features and advantages of the present invention will be apparent from the following more detailed description of the preferred embodiment, taken in conjunction with the accompanying drawings which illustrate, by way of example, the principles of the invention.

BRIEF DESCRIPTION OF THE DRAWINGS

[0013] FIG. 1 is a perspective schematic view of an exemplary fabrication process to produce an exemplary erosion shield according to the disclosure.

[0014] FIG. 2 is a perspective schematic view of an exemplary preparation process to produce an exemplary turbine component according to the disclosure.

[0015] FIG. 3 is a perspective schematic view of a pressing step in an exemplary fabrication process to produce an exemplary erosion shield according to the disclosure.

[0016] FIG. 4 is a perspective schematic view of a sintering step in an exemplary fabrication process to produce an exemplary erosion shield according to the disclosure.

[0017] FIG. 5 is a perspective schematic view of a finishing step in an exemplary fabrication process to produce an exemplary erosion shield according to the disclosure.

[0018] Wherever possible, the same reference numbers will be used throughout the drawings to represent the same parts.

DETAILED DESCRIPTION OF THE INVENTION

[0019] Provided is an exemplary process of fabricating a shield, a process of preparing a component, and an erosion shield. Embodiments of the present disclosure permit lower cost production of components and/or erosion shields, permit production of more reproducible turbine components and/or erosion shields, permit production within narrower tolerances/specifications, permit cost-effective production of complex-shaped components and/or shields (for example, those having cavities, non-parallel surfaces, round/curved surfaces, angled surfaces, protrusions, gaps, or other difficult to form shapes/geometries), reduce or eliminate processing, machining, and/or finishing, permit production of near-net

shape or net shape components and/or erosion shields, permit use of materials that are more readily available than those required by other techniques, permit an increase in production rates/speed, permit use of materials that are not available in wrought form, or combinations thereof.

[0020] FIG. 1 represents an embodiment of a fabrication process **100** for fabricating an erosion shield **101**. The fabrication process **100** includes forming (step **102**) the shield **101** as a near-net shape shield. As used herein, the phrase “near-net” refers to being of a geometry and size requiring little or no machining and processing. In a further embodiment, the shield **101** is a net shape shield. As used herein, the phrase “net” refers to being of a geometry and size requiring no machining and processing.

[0021] The shield **101** includes any suitable geometric features capable of being formed by use of a die **105**. Suitable geometric features include, but are not limited to, cavities, non-parallel surfaces, round/curved surfaces, angled surfaces, protrusions, gaps, or other difficult to form shapes/geometries. In one embodiment, the geometric features of the shield **101** substantially correspond or completely correspond with all or a portion of a component **201** (see FIG. 2) to be protected by the shield **101**.

[0022] Referring to FIG. 1, in one embodiment, the forming (step **102**) of the shield **101** includes positioning/applying (step **104**) material **103** into the die **105**. The die **105** includes any suitable geometry capable of forming the geometric features of the shield **101** and containing the material **103**. The material **103** is positioned/applied (step **104**) in the die **105**, for example, by an applicator **113** spraying (such as, thermal spraying and/or cold spraying), die casting, pouring, dripping, flowing, any suitable other application technique, or a combination thereof. In further embodiments, as shown in FIG. 3, the forming (step **102**) of the shield **101** includes pressing (step **300**) by application of force **301** and/or pressure, for example, to densify the material **103**, and/or sintering (step **400**), for example as shown in FIG. 4, to achieve a predetermined density, such as fully dense making the shield **101**. In a further embodiment, the sintering (step **400**) is performed within a furnace **401**, for example, at a temperature of between about 1450° F. and about 2100° F. In one embodiment, the pressing (**300**) includes compression of more than one layer of the shield **101**, for example, a nickel-based layer **107** (which may be referred to as a shim) and an erosion-resistant layer **109**. In a further embodiment, the sintering (step **400**) is under pressure, as well as being at the temperature, for example, as hot pressing or hot isostatic pressing.

[0023] Further embodiments include finishing (step **500**), for example as shown in FIG. 5, with a tool **501**, such as by machining, sanding, grit-blasting, cutting, treating, coating, or a combination thereof. Alternate embodiments are devoid of finishing and/or machining, sanding, grit-blasting, cutting, treating, coating, or a combination thereof.

[0024] The material **103** used in the forming (step **102**) corresponds to the nickel-based layer **107** and the erosion-resistant alloy layer **109** of the shield **101**. The erosion-resistant alloy layer **109** is positioned at least partially on the nickel-based layer **107**. In further embodiments, one or more additional nickel-based layers are present and/or one or more additional erosion-resistant alloy layers are present. In one embodiment, a first portion of the material **103** used in the forming (step **102**) is a nickel-based powder metal or alloy used for forming the nickel-based layer **107** and a

second portion of the material **103** is an erosion-resistant alloy for forming the erosion-resistant alloy layer **109**. Suitable erosion-resistant alloys include cobalt-based alloys, chromium-based alloys, tungsten-based alloy, chromium carbide materials, or combinations thereof. In one embodiment, the erosion-resistant alloy is a member of the STELLITE® family of alloys.

[0025] The nickel-based layer **107** is any suitable thickness capable of conferring desired properties. For example, in one embodiment, the thickness of the nickel-based layer **107** is selected to provide a sufficient transition between a substrate **203** (see FIG. 2) of the component **201** (see FIG. 2) and the erosion-resistant alloy layer **109**, thereby reducing or eliminating delamination, fatigue, welding difficulties, crack propagation, and/or other undesirable effects. For example, in one embodiment, the nickel-based layer **107** provides a barrier limiting carbon migration between the substrate **203** and higher carbon material in the erosion-resistant alloy layer **109**, thereby reducing or eliminating weakening of a weld or heat affected zone. Suitable thicknesses of the nickel-based layer **107** include, but are not limited to, between about 10 mils and about 200 mils, between about 10 mils and about 100 mils, between about 10 mils and about 50 mils, between about 10 mils and about 20 mils, between about 50 mils and about 100 mils, between about 50 mils and about 150 mils, between about 50 mils and about 200 mils, between about 100 mils and about 150 mils, between about 100 mils and about 200 mils, between about 150 mils and about 200 mils, up to about 50 mils, up to about 100 mils, up to about 150 mils, up to about 200 mils, greater than about 10 mils, greater than about 20 mils, greater than about 50 mils, greater than about 100 mils, greater than about 150 mils, at about 10 mils, at about 20 mils, at about 50 mils, at about 100 mils, at about 150 mils, at about 200 mils, or any suitable combination, sub-combination, range, or sub-range thereof.

[0026] The erosion-resistant alloy layer **109** is any suitable thickness conferring desired properties. In one embodiment, the thickness of the erosion-resistant alloy layer **109** is selected to confer a sufficient wear resistance and/or erosion-resistance, for example, over a predetermined life of a specific component/use. Suitable thicknesses of the erosion-resistant alloy layer **109** include, but are not limited to, between about 200 mils and about 500 mils, between about 200 mils and about 300 mils, between about 200 mils and about 400 mils, between about 300 mils and about 400 mils, between about 300 mils and about 500 mils, between about 400 mils and about 500 mils, up to about 200 mils, up to about 300 mils, up to about 400 mils, up to about 500 mils, greater than about 200 mils, greater than about 300 mils, greater than about 400 mils, at about 200 mils, at about 300 mils, at about 400 mils, at about 500 mils, or any suitable combination, sub-combination, range, or sub-range thereof.

[0027] FIG. 2 represents an embodiment of a preparation process **200** for preparing the component **201**, such as a turbine component. Suitable components capable of being protected by the shield **101** include, but are not limited to, a blade or airfoil, a nozzle, a valve, a diaphragm, a bucket, a rotor, or a combination thereof.

[0028] The preparation process **200** for preparing the component **201** includes securing (step **202**) the shield **101** to the substrate **203** of the component **201**. In one embodiment, the substrate **203** is an iron-based or nickel-based alloy. One suitable alloy has a composition, by weight, of

about 0.15% carbon, about 1.00% manganese, about 0.50% silicon, between about 11.5% and about 13.0% chromium, about 0.04% phosphorus, about 0.03% sulfur, and a balance of iron. Another suitable alloy has a composition, by weight, of about 0.14% carbon, about 0.80% manganese, about 0.015% phosphorous, about 0.010% sulfur, about 0.2% silicon, about 11.5% chromium, about 2.5% nickel, about 1.6% molybdenum about 0.3% vanadium, about 0.03% nitrogen and a balance of iron. Another suitable alloy has a composition, by weight, of about 0.050% carbon, between about 14.0% and about 16.0% chromium, between about 1.25% and about 1.75% copper, about 1.0% manganese, between about 0.50% and about 1.0% molybdenum, between about 5.0% and about 7.0% nickel, about 0.30% phosphorus, about 1.0% silicon, about 0.030% sulfur, and a balance of iron. In one embodiment, the securing (step 202) includes positioning the shield 101 onto the substrate 203 opposite the erosion-resistant alloy layer 109. In one embodiment, the securing (step 202) is by a technique selected from the group consisting of brazing, laser welding, electron beam welding, plasma welding, tungsten inert gas welding, and combinations thereof.

[0029] While the invention has been described with reference to a preferred embodiment, it will be understood by those skilled in the art that various changes may be made and equivalents may be substituted for elements thereof without departing from the scope of the invention. In addition, many modifications may be made to adapt a particular situation or material to the teachings of the invention without departing from the essential scope thereof. Therefore, it is intended that the invention not be limited to the particular embodiment disclosed as the best mode contemplated for carrying out this invention, but that the invention will include all embodiments falling within the scope of the appended claims.

What is claimed is:

1. A near-net shape shield, comprising:
 - a nickel-based layer; and
 - an erosion-resistant alloy layer positioned at least partially on the nickel-based layer;
 - the near-net shape shield having a near-net shape with a geometry and a size requiring little or no machining or processing after the near-net shape is formed within a die;
 - wherein, prior to attachment to a turbine component, the near-net shape shield is configured to be positioned on a surface of the turbine component; and
 - wherein the geometry of the near-net shape shield comprises at least one feature selected from the group consisting of cavities, protrusions, gaps, and combinations thereof.
2. The near-net shape shield of claim 1, wherein the at least one feature corresponds with at least a portion of the surface of the turbine component.
3. The near-net shape shield of claim 1, wherein the turbine component comprises an iron-based or nickel-based substrate positioned on at least a portion of the nickel-based layer of the near-net shape shield.
4. The near-net shape shield of claim 3, wherein the turbine component is a turbine blade.
5. The near-net shape shield of claim 3, wherein the erosion-resistant alloy layer is a cobalt-based alloy, a chromium-based alloy, a tungsten-based alloy, or a combination thereof.

6. The near-net shape shield of claim 1, wherein the nickel-based layer has a thickness of between about 10 mils and about 200 mils.

7. The near-net shape shield of claim 1, wherein the erosion-resistant alloy layer has a thickness of between about 200 mils and about 500 mils.

8. The near-net shape shield of claim 1, wherein the near-net shape requires no machining or processing after forming the near-net shape shield within the die.

9. A fabrication process comprising:

securing a near-net shape shield to a substrate of a component;

wherein the near net shape shield comprises a nickel-based layer and an erosion-resistant alloy layer positioned at least partially on the nickel-based layer;

wherein the near-net shape shield has a near-net shape with a geometry and a size requiring little or no machining or processing after the near-net shape is formed;

wherein, prior to attachment to the substrate of the component, the near-net shape shield is configured to be positioned on the substrate of the component; and

wherein the geometry of the near-net shape shield comprises at least one feature selected from the group consisting of cavities, protrusions, gaps, and combinations thereof.

10. The fabrication process of claim 9, wherein the securing is by a technique selected from the group consisting of brazing, laser welding, electron beam welding, plasma welding, tungsten inert gas welding, and combinations thereof.

11. The fabrication process of claim 9, wherein the at least one feature corresponds with at least a portion of the substrate of the component.

12. The fabrication process of claim 9 further comprising forming the near-net shape shield to the near-net shape within a die.

13. The fabrication process of claim 9, wherein the near-net shape requires no machining or processing after forming the near-net shape shield within the die.

14. The fabrication process of claim 9, wherein the at least one feature corresponds with at least a portion of the component.

15. The fabrication process of claim 9, wherein the component comprises an iron-based or nickel-based substrate positioned on at least a portion of the nickel-based layer of the near-net shape shield.

16. The fabrication process of claim 9, wherein the component is a turbine blade.

17. A fabrication process comprising:

forming a shield to a net shape within a die, the net shape including a geometry and size requiring no machining or processing after forming the shield within the die and corresponding to a surface of a component to be protected by the shield and configured to be attached to the surface of the component;

wherein the shield includes a nickel-based layer and an erosion-resistant alloy layer positioned at least partially on the nickel-based layer; and

wherein the geometry of the near-net shape shield comprises at least one feature selected from the group consisting of cavities, protrusions, gaps, and combinations thereof.

18. The fabrication process of claim **17**, wherein the at least one feature corresponds with at least a portion of the surface of the component.

19. The fabrication process of claim **17** further comprising securing the shield to the surface of the component.

20. The fabrication process of claim **99**, wherein the securing is by a technique selected from the group consisting of brazing, laser welding, electron beam welding, plasma welding, tungsten inert gas welding, and combinations thereof.

* * * * *