



US 20240154337A1

(19) **United States**

(12) **Patent Application Publication**
Villarreal et al.

(10) **Pub. No.: US 2024/0154337 A1**

(43) **Pub. Date: May 9, 2024**

(54) **METHOD OF CONNECTING ELECTRICAL COMPONENTS**

Publication Classification

(71) Applicant: **Cadwell Laboratories, Inc.**,
Kennewick, WA (US)

(51) **Int. Cl.**
H01R 13/11 (2006.01)
H01R 13/24 (2006.01)
H01R 13/52 (2006.01)

(72) Inventors: **Richard A. Villarreal**, West Richland,
WA (US); **David Lee Jepsen**,
Kennewick, WA (US)

(52) **U.S. Cl.**
CPC *H01R 13/111* (2013.01); *H01R 13/2485*
(2013.01); *H01R 13/5202* (2013.01); *H01R*
2107/00 (2013.01)

(21) Appl. No.: **18/479,083**

(57) **ABSTRACT**

(22) Filed: **Oct. 1, 2023**

A connector receptacle for connecting with a corresponding connector plug coupled with electrodes being used for performing EMG procedure on a patient is provided. The receptacle includes a first ball bearing pressing against a first end of a housing of the plug and, preferably, a second ball bearing pressing against a first end of the housing of the plug when the plug is connected to the receptacle for exerting a retention force against the plug. The first and the second ball bearings are pressed against the first and the second ends respectively by using a spring force generated, for example, by a retention band.

Related U.S. Application Data

(63) Continuation of application No. 17/445,800, filed on Aug. 24, 2021, now Pat. No. 11,777,243, which is a continuation of application No. 16/747,748, filed on Jan. 21, 2020, now Pat. No. 11,128,076.

(60) Provisional application No. 62/794,884, filed on Jan. 21, 2019.

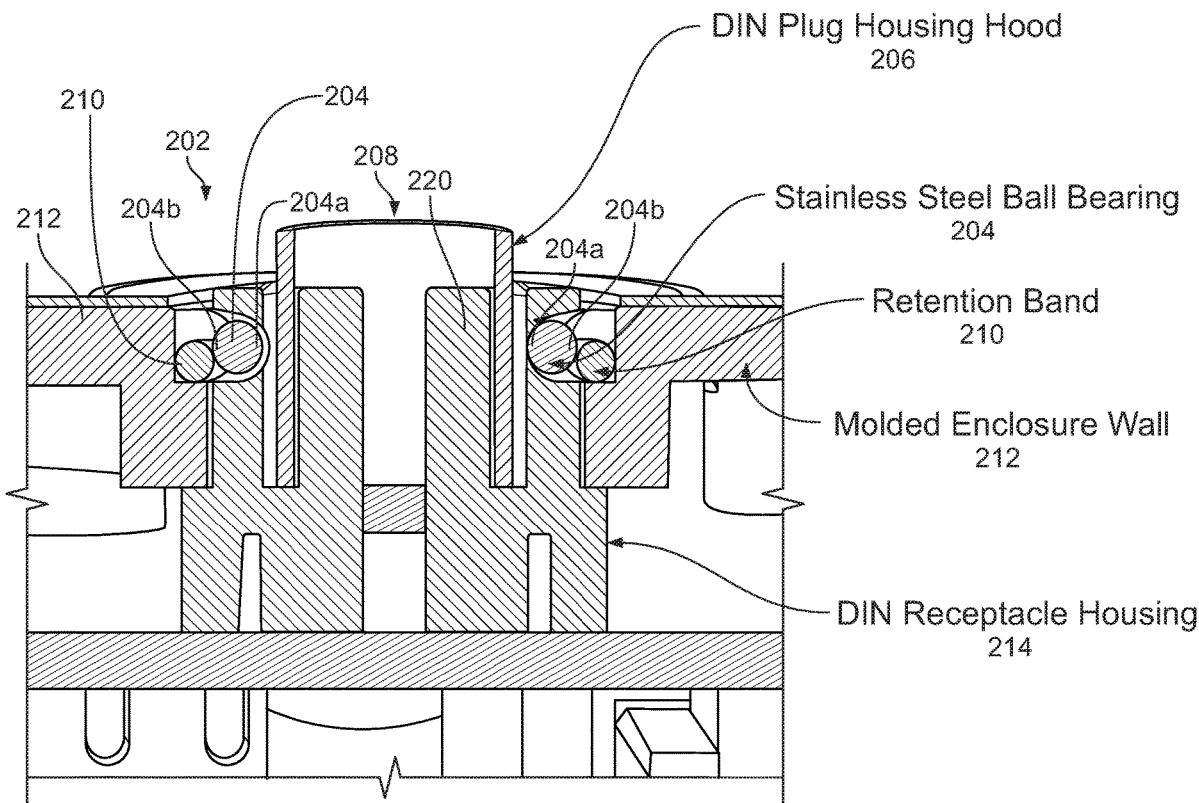

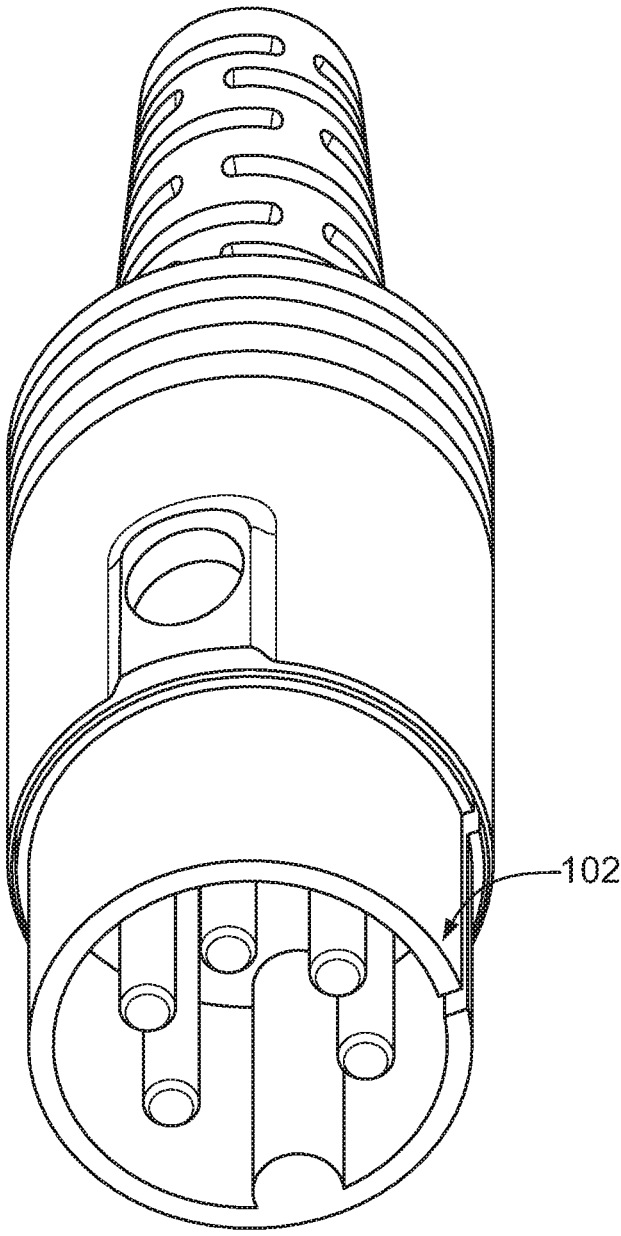

FIG. 1A
(Prior Art)

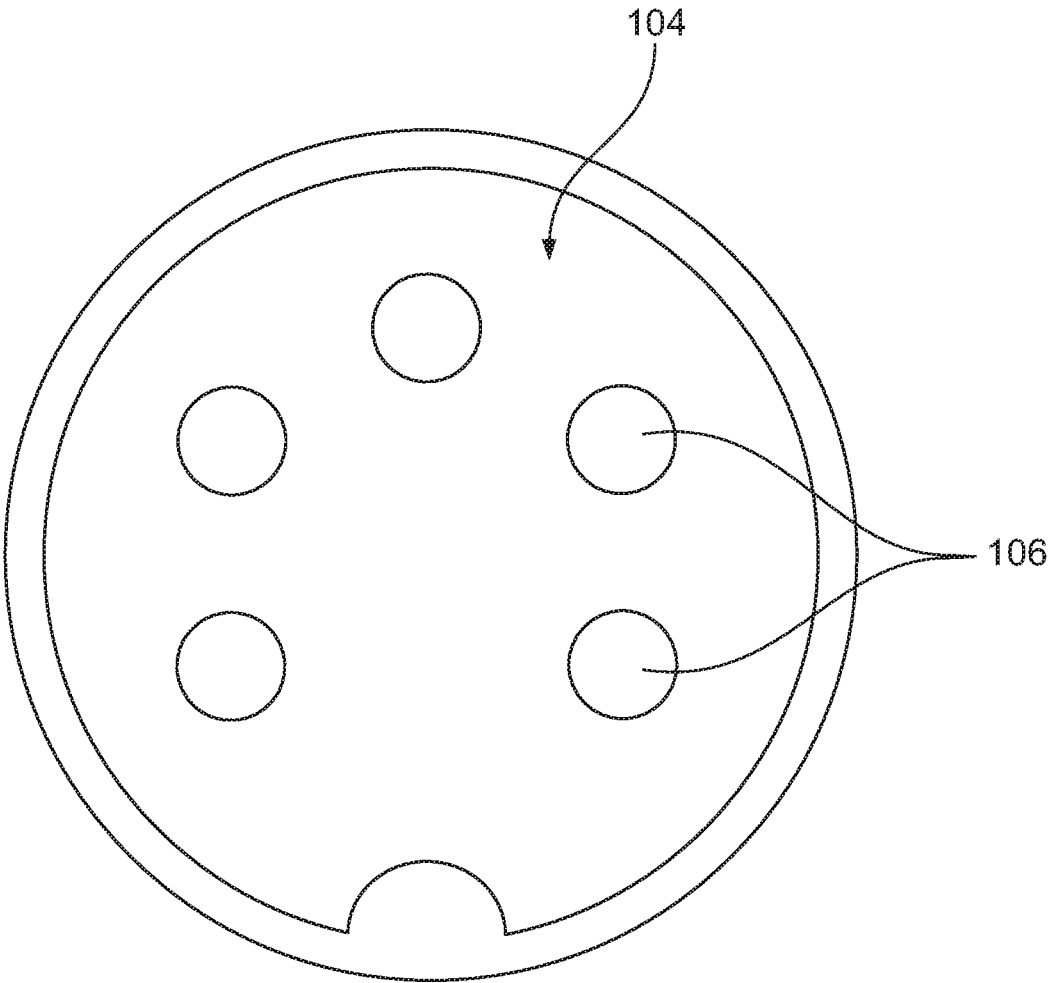

FIG. 1B
(Prior Art)

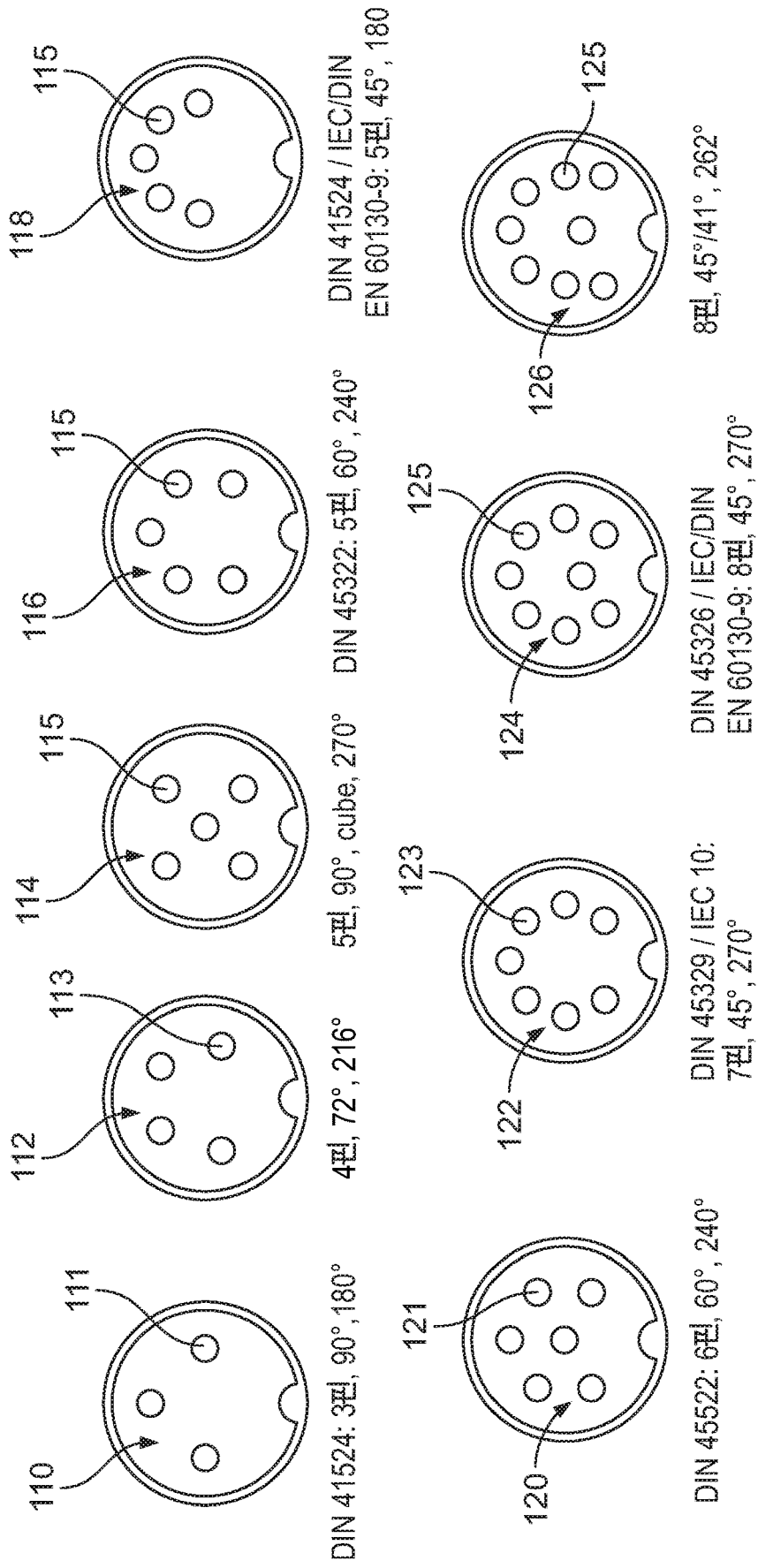

FIG. 1C
(Prior Art)

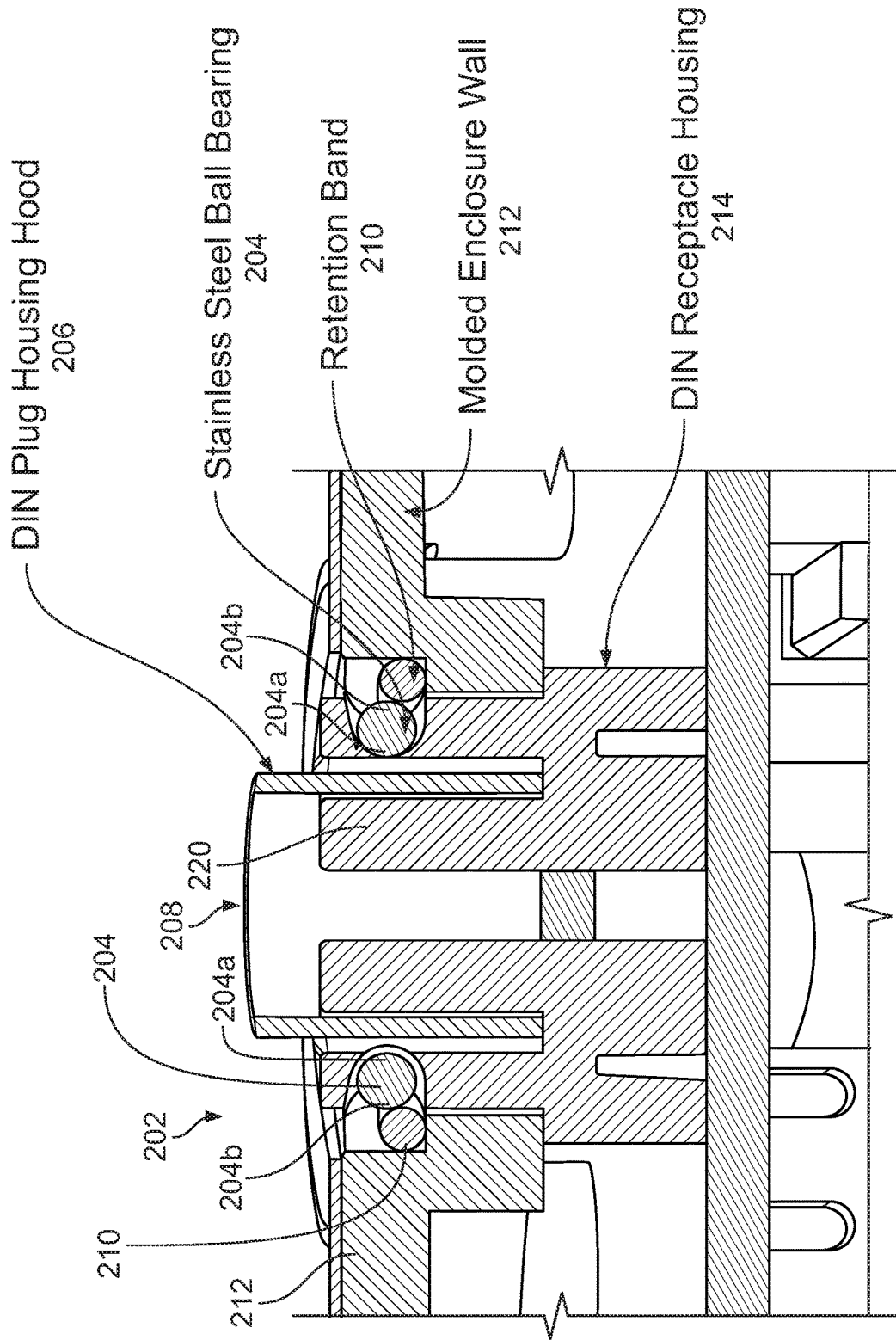

FIG. 2A

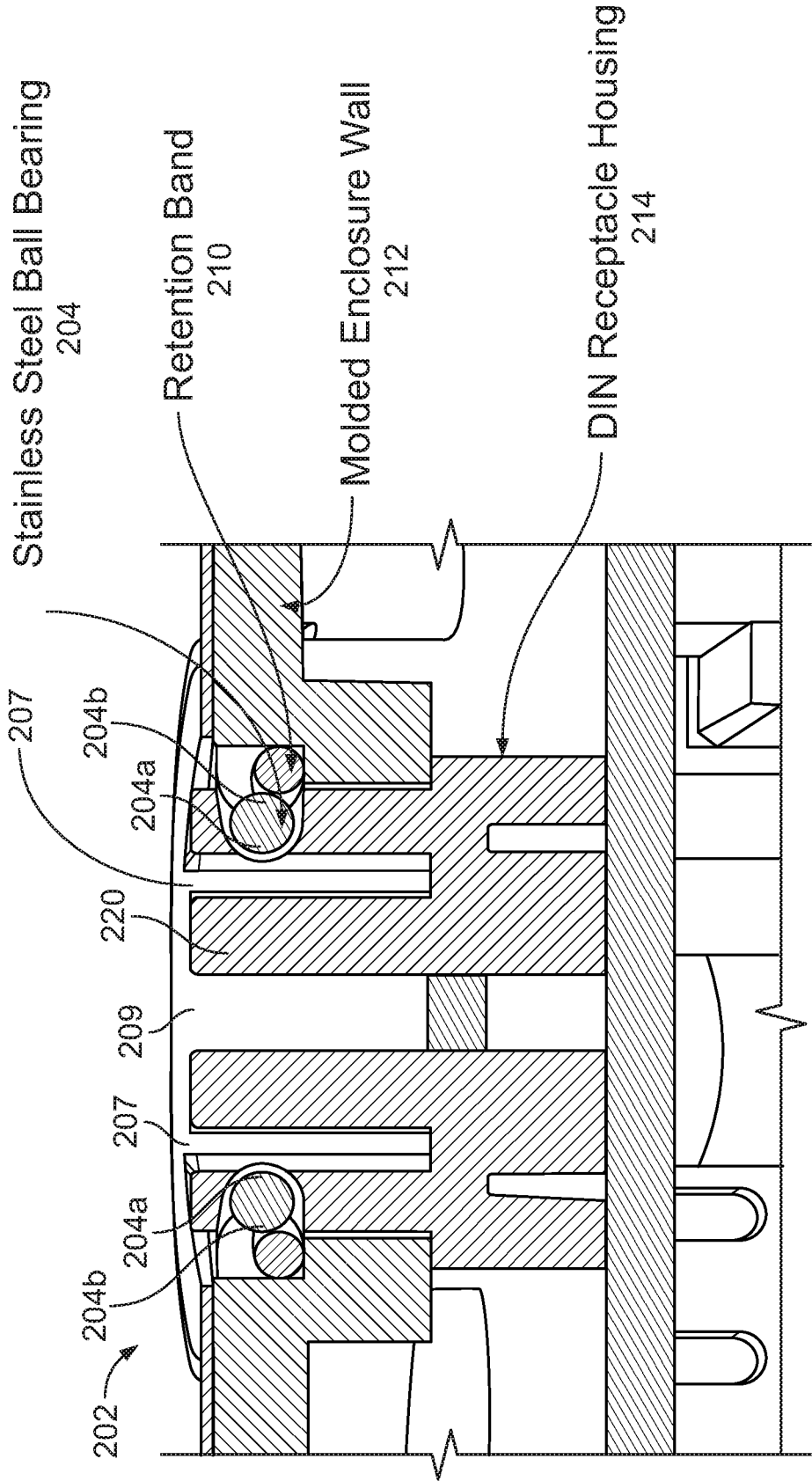

FIG. 2B

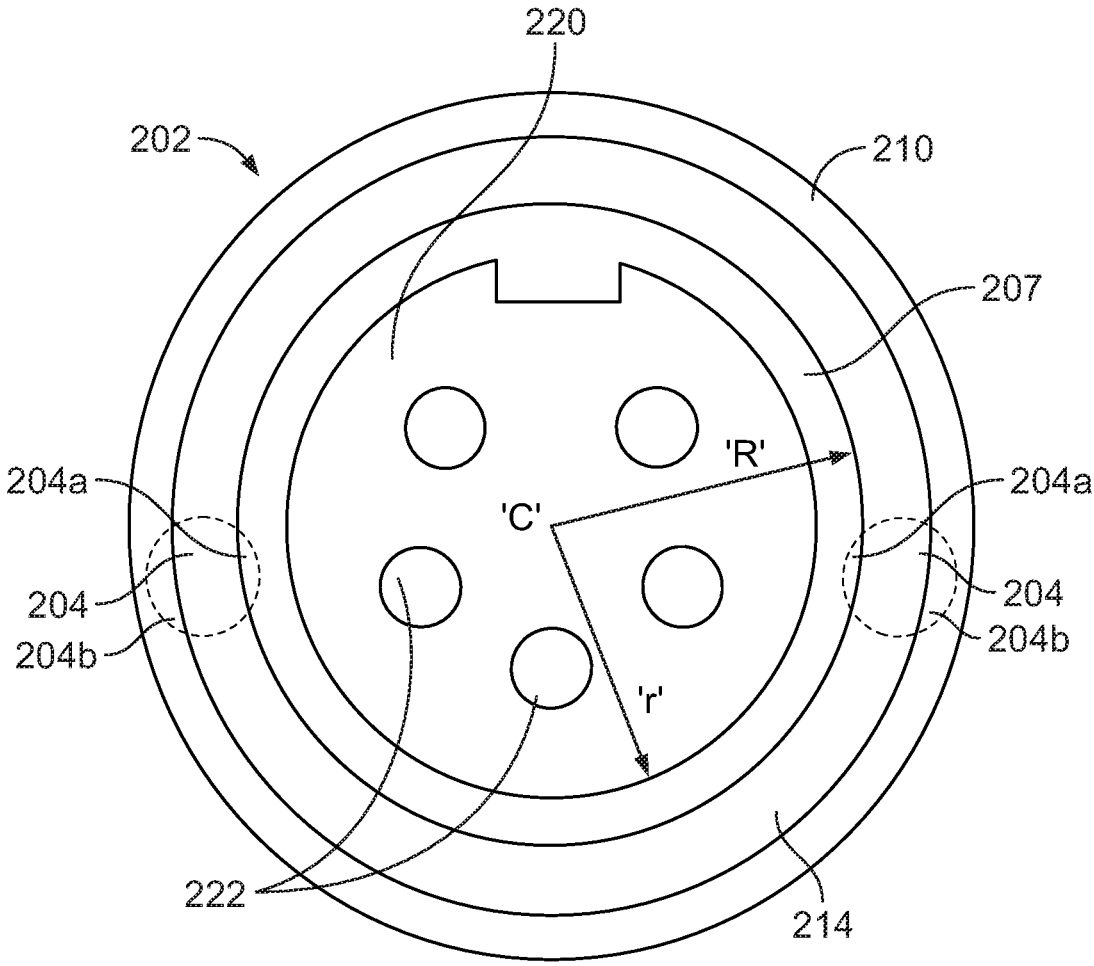

FIG. 2C

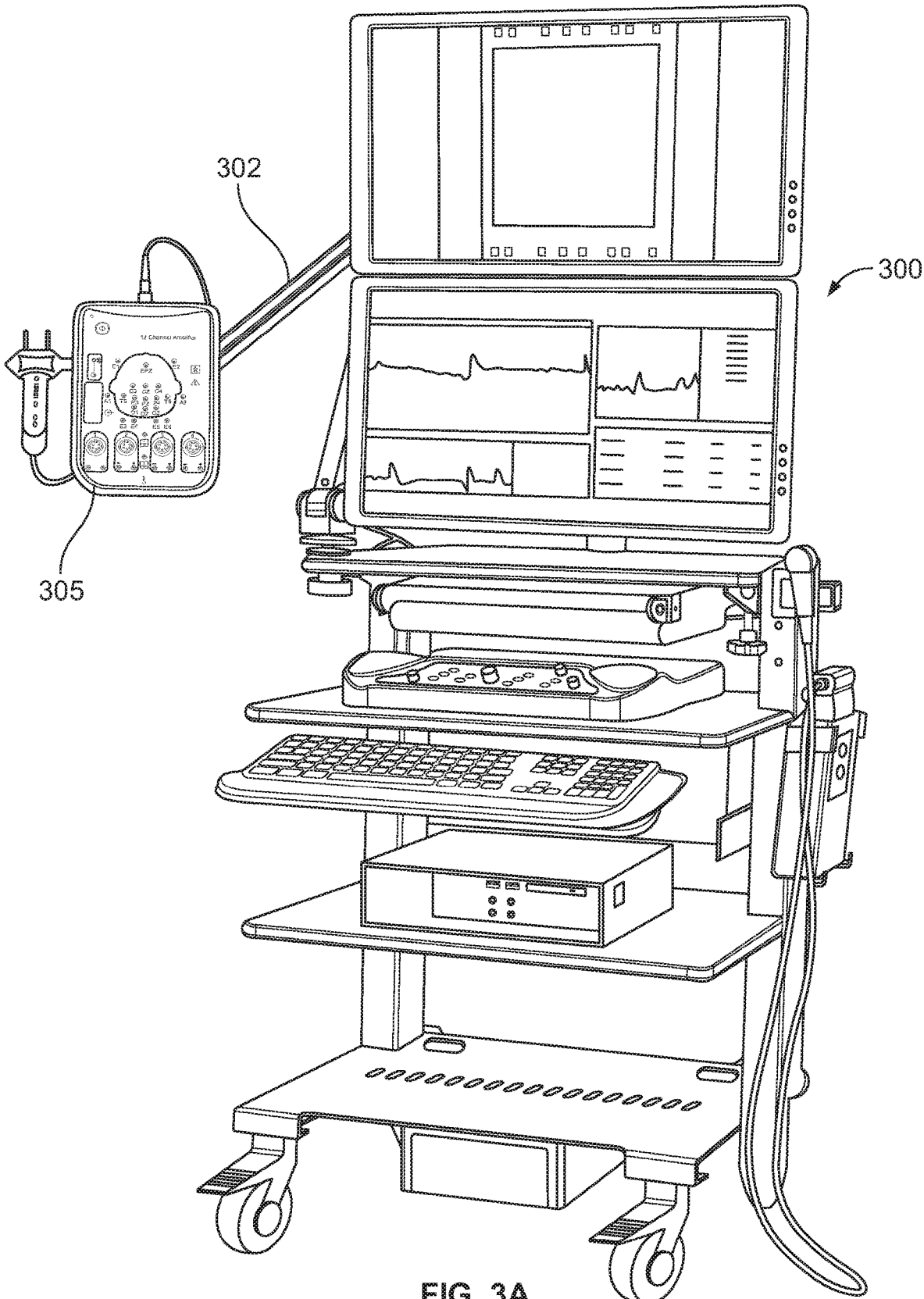

FIG. 3A

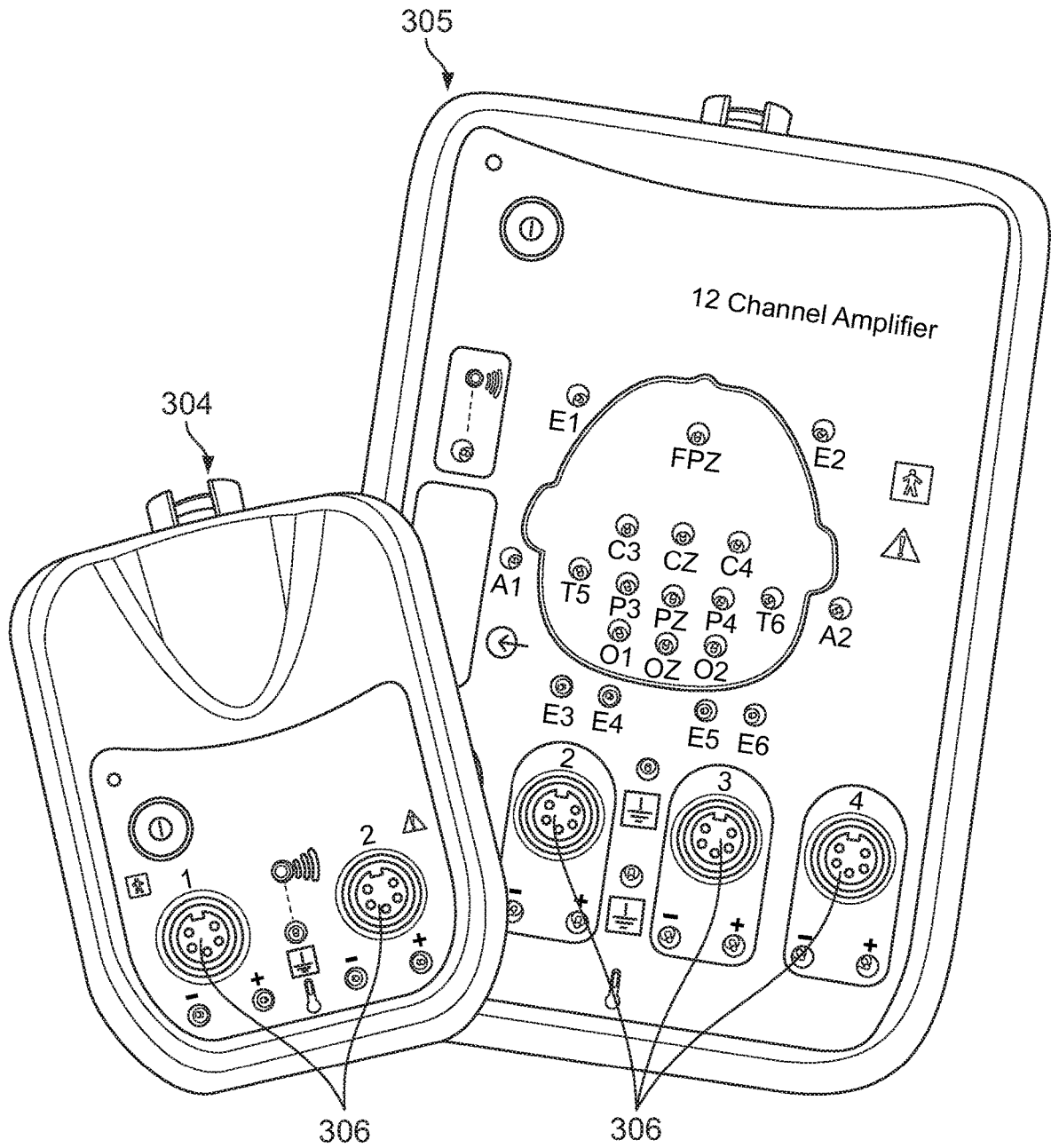

FIG. 3B

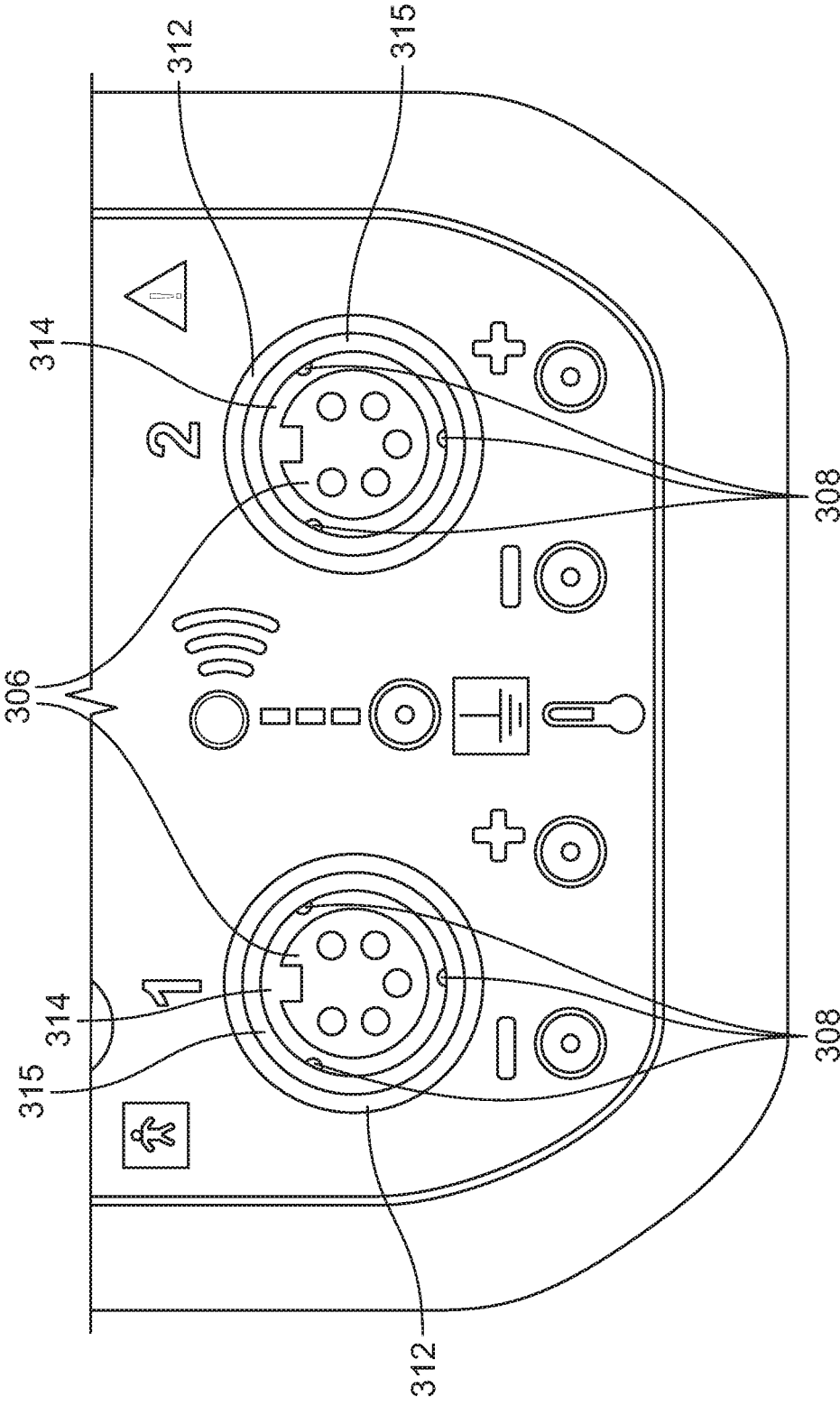

FIG. 3C

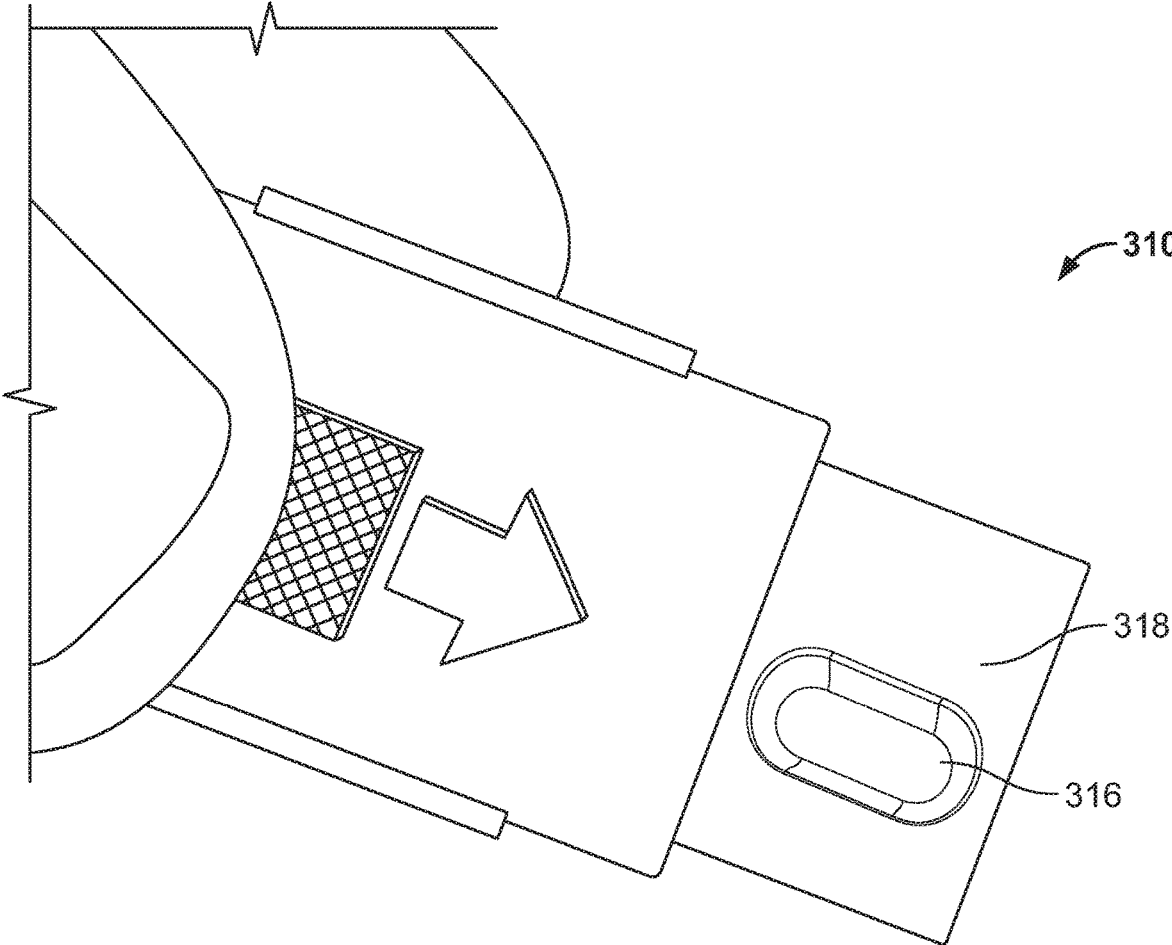

FIG. 3D

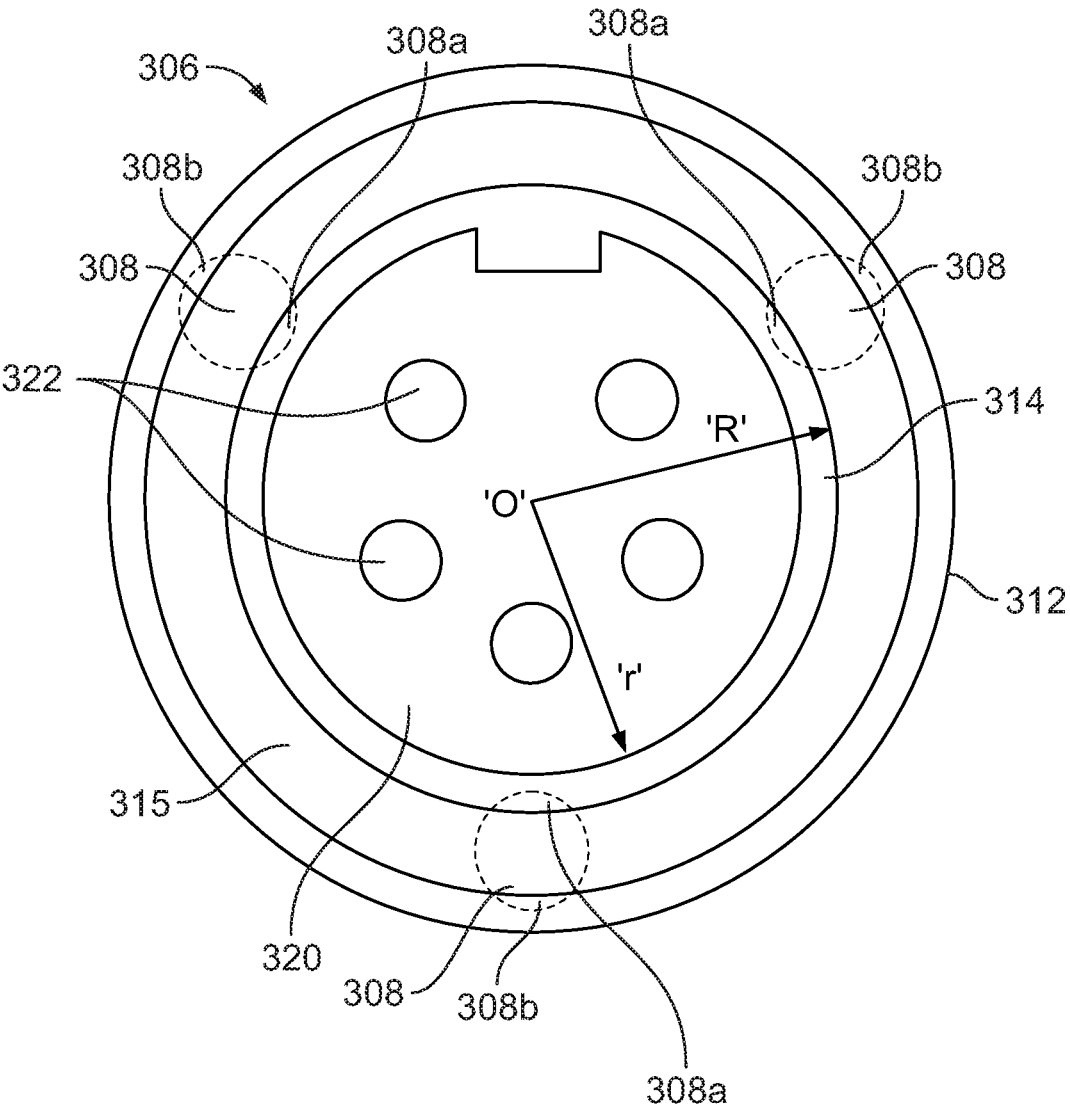

FIG. 3E

METHOD OF CONNECTING ELECTRICAL COMPONENTS

CROSS-REFERENCE

[0001] The present application is a continuation application of U.S. patent application Ser. No. 17/445,800, entitled "Connector Receptacle with Improved Mating Retention and Release" and filed on Aug. 24, 2021, which is a continuation application of U.S. patent application Ser. No. 16/747,748, entitled "Connector Receptacle", filed on Jan. 21, 2020, and issued as U.S. Pat. No. 11,128,076 on Sep. 21, 2021, which relies on U.S. Patent Provisional Application No. 62/794,884, of the same title and filed on Jan. 21, 2019, for priority, both of which are herein incorporated by reference in their entirety.

FIELD

[0002] The present specification generally relates to female DIN receptacles, and particularly to a resilient circular female DIN receptacle configured to maintain mating retention and withstand a high number of mating cycles.

BACKGROUND

[0003] Electrophysiological methods, such as electroencephalography (EEG), electromyography (EMG), and evoked potentials, measure the functional integrity of certain neural structures (e.g., nerves, spinal cord and parts of the brain). Neurodiagnostics is the use of electrophysiological methods, such as electroencephalography (EEG), electromyography (EMG), and evoked potentials (EP), to diagnose the functional integrity of certain neural structures (e.g., nerves, spinal cord and parts of the brain) to assess disease states and determine potential therapy or treatment. With EMG and EPs, a neurologist typically utilizes electrodes applied to the patient near the nerves being assessed. These electrodes used are in many forms including needles, metal disks, and conductive pads. Each of these electrodes is coupled to a wire lead which, in turn, is connected to an amplifier for amplification of the EMG or EP electrical signals. The wire leads are usually coupled with standard connectors comprising a male plug which fits into a corresponding female receptacle for connecting with the control unit of monitoring equipment, such as, for example, EMG monitoring equipment. The electrical activity pattern captured by various electrodes is analyzed using standard algorithms to localize or spot the portion of brain which is responsible for causing the specific ailment.

[0004] During a typical EMG and EP study, the electrodes are connected and disconnected many times, thus requiring a connector that can withstand many mating cycles. After many mating cycles, the connector must maintain reliable electrical connectivity and mating force. An appropriate mating force is necessary since a low mating force may result in the connector being pulled out of the amplifier during the EMG or EP study.

[0005] The standard Deutsches Institut für Normung (DIN) connector, for example, a 45322 DIN connector (5 position circular), is a default standard connector used in EMG equipment. Both recording and stimulating electrodes may terminate with male DIN connector plugs. During the course of a patient examination, the connector may be mated/unmated multiple times. The number of mating cycles on a daily basis may exceed 20 depending on the

application. Commercially available circular female DIN connector receptacles are typically rated for 1000 mating cycles.

[0006] Current methods of securing a DIN connector are not suitable for use with an EMG or EP instrument. These methods include spring fingers and some sort of latching mechanism. Spring fingers have limited mating cycles below what is required for EMG/EP instruments. Latching mechanisms for DIN connectors are not desirable for the following reasons: requires a non-standard DIN plug that would limit the possibility of available electrodes, add cost to the electrode, and require more effort, such as twisting or pressing, to remove the DIN plug from the amplifier.

[0007] FIG. 1A illustrates a standard prior art circular male DIN plug, such as a male DIN 45322 plug. FIG. 1B illustrates a prior art female DIN receptacle for the male DIN plug shown in FIG. 1A. In order to enable connection, male DIN plug 102 and female DIN receptacle 104 are mated by fitting the male DIN plug 102 into female DIN receptacle 104. Removing the male DIN plug 102 from the female DIN receptacle 104 results in un-mating or breaking the connection. Beyond 1000 cycles of mating/un-mating, the female DIN receptacle 104 may experience poor electrical contact and retention force of the male DIN connector plug 102.

[0008] The retention force of commercially available DIN receptacles relies on the friction between the DIN plug prong and the DIN receptacle pin socket. One type of pin socket is tulip shaped. The poor retention force is due to an elasticity and/or mechanical breakdown of the tulip shaped contacts 106 in the female DIN receptacle 104. The tulip shaped contacts 106 are subject to distortion after repeated mating cycles. Thus, for a female DIN receptacle that is rated for 1000 cycles, the receptacle starts losing its electric contact and retention force after 50 days of use in EMG equipment. Another type of pin socket is a circular contact. Certain variations of the circular contact have superior electrical contact with high mating cycles. However, the retention force of the circular contact is low. Low retention force of the female DIN receptacle is problematic since the electrode may disconnect from the EMG equipment as the electrode is moved about the patient during the examination.

[0009] FIG. 1C illustrates a plurality of standard prior art circular female DIN receptacles. FIG. 1C depicts:

[0010] A first female DIN receptacle 110, also referred to as a DIN 41524 receptacle, having three contacts 111, each configured to receive a pin;

[0011] A second female DIN receptacle 112 having four contacts 113, each configured to receive a pin;

[0012] A third female DIN receptacle 114, also referred to as a DIN 45327 receptacle, having five contacts 115, each configured to receive a pin and further configured with a central contact surrounded by four equidistant contacts;

[0013] A fourth female DIN receptacle 116, also referred to as a DIN 45322, having five contacts 115, each configured to receive a pin and further configured with a central contact positioned between two right and two left contacts placed in parallel;

[0014] A fifth female DIN receptacle 118, also referred to as a DIN 41524 receptacle, having five contacts 115, each configured to receive a pin and further configured in an arc;

[0015] A sixth female DIN receptacle **120**, also referred to as a DIN 45522 receptacle, having six contacts **121**, each configured to receive a pin;

[0016] A seventh female DIN receptacle **122**, also referred to as a DIN 45329 receptacle, having seven contacts **123**;

[0017] An eighth female DIN receptacle **124**, also referred to as a DIN 45326 receptacle, having eight contacts **125** as shown in FIG. 1C; and

[0018] A ninth female DIN receptacle **126** having eight contacts **125** as shown in FIG. 1C.

[0019] U.S. Pat. No. 4,284,313, assigned to ITT Corporation, discloses a detachable electrical connector in which “a resilient hood on the receptacle connector member surrounds the forward portion of the plug connector member. Lugs on the plug connector member snap into recesses in the hood to latch the connector members together. The hood is connected to the body of the receptacle member by longitudinally extending ribs. In one embodiment of the invention, the hood is circular and is rotated to ride up over the latching lugs to release the lugs from the recesses, thereby allowing the connector members to be disengaged.”

[0020] U.S. Pat. No. 4,842,555, assigned to AMP Incorporated, discloses a surface mounted electrical connector which “has a metal shield (**12**) having a front plate (**28**) with a circular opening (**30**) for receiving a shielded socket (**18**) of a mating connector (**20**), to allow it to mate with a plug portion (**16**) of the surface mounted connector (**10**). Spring fingers (**34**) project from the edge (**32**) of the opening (**30**) for engaging shielding (**19**) of the mating connector (**20**). Between a pair of the fingers (**34**) there also projects from the edge (**32**), a latching finger (**80**) which is shorter than the spring fingers (**34**), for latching behind a depressable protuberance (**90**) on the socket (**18**). When the plug portion (**16**) is to be mated with the socket (**18**), a flexible arm (**98**) in the socket (**18**), which carries the protuberance (**90**) is supported by a support bar (**88**) which is stiffly resilient. During mating, the protuberance (**90**) displaces the latching finger (**80**) and latches behind its free end (**84**). A sleeve (**100**) on the mating connector (**20**) can be pulled to withdraw the support bar (**98**) so that the protuberance can slide under the latching finger (**80**) to allow the connectors (**10** and **20**) to be unmated.”

[0021] U.S. Pat. No. 5,035,650, assigned to AMP Incorporated, discloses “a dielectric housing (**4**) of a circular, shielded DIN electrical connector (**2**) [which] comprises a central block (**26**) with terminal receiving cavities (**18**) extending axially therethrough and which cooperates with a hood (**30**) and a base (**28**) of the housing (**4**) to define a circular chamber receiving a circular, stamped and formed metal shield (**8**). The shield (**8**) has projecting therefrom a uniplanar latch arm (**80**) having a head (**81**) which latches positively against a latching shoulder (**88**) in a slot in the base. The latch arm (**80**) is deflected in its own plane by a cam surface in the slot as the latch arm (**80**) is inserted therinto and then resiles to allow the head (**81**) to latch against the shoulder (**88**).”

[0022] U.S. Pat. No. 5,871,371, assigned to The Whitaker Corporation, discloses “an electrical connector for providing connection for a plurality of coaxial cable disposed in a shielded cable. The connector includes a contact housing having a plurality of signal and ground contacts mounted therein. The contact housing has an outer periphery. The signal and ground contacts are disposed about the outer

periphery of the contact housing. The signal and ground contacts each have contact sections and connection sections for forming an electrical connection with the signal and ground from a coaxial cable.”

[0023] U.S. Pat. No. 6,183,293, assigned to ITT Manufacturing, Inc., discloses an “electrical connector for mounting in an opening (**2**) of a wall (**3**), [which] includes a connector element (**4**) having a bayonet threaded shaft (**7**) that projects into the opening and a clamp element (**5**) with a nut part that can be threaded onto the threaded shaft until shoulders on the two elements abut the wall, where the connector includes a latching mechanism (**40**) that prevents loosening of the clamp member. The latching mechanism includes a holder ring (**54**) on the connector element, that lies within a latch ring (**50**) on the clamp element. The latch ring has inwardly-extending projections (**42**, **44**), while the holder ring carries at least one latch member (**14**). When the clamping member is tightened on the connector element, the distal end (**15a**) of the latch member readily rides over the projections. However, when the clamping member begins to loosen, the distal end resists such loosening.”

[0024] U.S. Pat. No. 9,088,103, assigned to Omnetics Connector Corporation, discloses an “apparatus and system for securing a mated connector pair with a latch. The latch is a unitary elongate body configured to receive the mated connector pair. The latch may include a spring member and an internal passageway configured to receive a miniature circular connector. The latch may include a wire retainer feature to secure the latch to a wire harness.”

[0025] The prior art does not address the need for greater retention force between the plug and receptacle of a DIN connector without the use of a latching mechanism. The prior art also does not provide a DIN connector that does not deteriorate by repeated mating cycles of its plug and receptacle.

[0026] Hence, there is a need for a DIN connector receptacle with an improved rating of multiples of 1000 cycles, which is compatible with the standard DIN connector plug to consistently provide a reliable connection over thousands of uses. There is also a need for an improved DIN receptacle which is not worn out by repeated mating and un-mating cycles and is corrosion resistant. Since receptacles comprising spring leaf type clips tend to flatten out after repeated cycles, which results in loss of retention force, there is also a need for a receptacle design which would support multiple mating cycles without loss of retention with standard DIN plugs and with no cost increase for the DIN plug.

SUMMARY

[0027] The following embodiments and aspects thereof are described and illustrated in conjunction with systems, tools and methods, which are meant to be exemplary and illustrative, not limiting in scope.

[0028] In some embodiments, the present specification discloses a receptacle configured to receive a plug comprising a plurality of pins, wherein the receptacle comprises a first housing having a circular enclosure wall defined by an exterior surface and an interior surface, wherein the interior surface of the enclosure wall encircles an interior space of the first housing, wherein the circular enclosure wall comprises at least one cavity; a plug receiver having an exterior surface and positioned within the interior space of the first housing, wherein the interior surface of the wall circumferentially surrounds the exterior surface of the plug receiver

and is separated from the exterior surface of the plug receiver by a circular gap, and wherein the plug receiver comprises a plurality of connectors each configured to receive one of the plurality of pins of the plug; a first protrusion member positioned in the at least one cavity within the circular enclosure wall; and a retention band circumferentially positioned around the interior space and in physical communication with the circular enclosure wall, wherein the retention band is configured to physically force the first protrusion member out of the at least one cavity and into the circular gap.

[0029] Optionally, the first protrusion member is a ball bearing.

[0030] Optionally, the retention band is positioned within a groove extending circumferentially around the interior surface of the enclosure wall.

[0031] Optionally, the receptacle is a female DIN connector receptacle.

[0032] Optionally, the plug is a male DIN connector plug.

[0033] Optionally, the first protrusion member is a ball bearing and wherein the ball bearing is made of stainless steel.

[0034] Optionally, the receptacle is configured to connect EMG electrodes with an EMG control system via an amplifier.

[0035] Optionally, the at least one cavity comprises a first cavity and a second cavity and further comprising a second protrusion member positioned in the second cavity, separate and distinct from the first cavity, within the circular enclosure wall.

[0036] Optionally, the retention band is configured to physically force the second protrusion member out of the second cavity and further into the circular gap.

[0037] Optionally, the first protrusion member and the second protrusion member are positioned 180 degrees from each other on opposite sides of the circular enclosure wall.

[0038] Optionally, the first protrusion member is a ball bearing, the second protrusion member is a ball bearing, and both the first protrusion member and second protrusion member are configured to be pressed against an outside surface of the plug by a spring force provided by the retention band.

[0039] Optionally, the first housing and the plug receptacle are molded.

[0040] Optionally, the retention band is an O-ring having a durometer rating in a range of 50 to 90 Shore.

[0041] Optionally, the receptacle further comprises a second protrusion member positioned in a second cavity, separate and distinct from the at least one cavity, within the circular enclosure wall and a third protrusion member positioned in a third cavity, separate and distinct from the second cavity and the at least one cavity, within the circular enclosure wall.

[0042] Optionally, the retention band is an O-ring having a durometer rating in a range of 50 to 90 Shore.

[0043] Optionally, the retention band is configured to physically force the second protrusion member out of the second cavity and further into the circular gap and to physically force the third protrusion member out of the third cavity and further into the circular gap.

[0044] Optionally, the first protrusion member, the second protrusion member, and the third protrusion member are positioned 120 degrees from each other circumferentially around the circular enclosure wall.

[0045] In some embodiments, the present specification discloses a female receptacle configured to connect to a male plug, wherein the female receptacle comprises a first circular housing circumferentially surrounding a plug receptacle, wherein an internal surface of the first circular housing is separated from the plug receptacle by a circular gap and wherein the plug receptacle comprises a plurality of hollow connector spaces each configured to receive a pin of the male plug, the female receptacle further comprising: a first state wherein a first protrusion member is configured to be positioned in a first cavity within the first circular housing and a retention band is configured to be circumferentially positioned around a surface of the first circular housing and physically force the first protrusion member out of the first cavity and further into the circular gap by a first distance; and a second state wherein the first protrusion member is configured to be positioned in the first cavity within the first circular housing and the retention band is configured to be circumferentially positioned around the surface of the first circular housing and physically force the first protrusion member out of the first cavity and further into the circular gap by a second distance, wherein the second distance is less than the first distance and wherein the second state is achieved by inserting the male plug into the female receptacle.

[0046] Optionally, the first protrusion member is a ball bearing.

[0047] Optionally, the female receptacle further comprises a second cavity, separate and distinct from the first cavity, in the first circular housing and a second protrusion member positioned in the second cavity within the circular enclosure wall.

[0048] Optionally, the retention band is configured to physically force the second protrusion member out of the second cavity and further into the circular gap.

[0049] In some embodiments, the present specification discloses a connector receptacle for connecting with a corresponding connector plug coupled with electrodes being used for performing EMG procedure on a patient, the receptacle comprising: a first ball bearing pressing against a first end of a housing of the plug and a second ball bearing pressing against a first end of the housing of the plug when the plug is connected to the receptacle for exerting a retention force against the plug, wherein the first and the second ball bearings are pressed against the first and the second ends respectively by using a spring force.

[0050] Optionally, the connector receptacle comprises a high mating cycle circular DIN connector receptacle.

[0051] Optionally, said receptacle is compatible with a DIN connector plug.

[0052] Optionally, the first and the second ball bearings are made of stainless steel.

[0053] Optionally, the spring force is provided by at least one retention band.

[0054] Optionally, the retention band comprises a high durometer and low compression set O-ring.

[0055] Optionally, the retention band exerts a compression force against the first and the second ball bearings, the compression force being transmitted to the housing of the plug for retaining the plug within the receptacle.

[0056] Optionally, the spring force is provided by using a circular spring.

[0057] Optionally, the spring force is provided by winding a circular spring around a center portion of the receptacle for pushing the first and the second ball bearings against the housing of the plug.

[0058] Optionally, the spring force is provided by using a coiled spring to push the ball bearings inwards towards the housing of the plug when the plug is connected to the receptacle.

[0059] Optionally, the receptacle comprises a molded enclosure encompassing a housing of the receptacle.

[0060] The aforementioned and other embodiments of the present specification shall be described in greater depth in the drawings and detailed description provided below.

BRIEF DESCRIPTION OF THE DRAWINGS

[0061] These and other features and advantages of the present specification will be appreciated, as they become better understood by reference to the following detailed description when considered in connection with the accompanying drawings, wherein:

[0062] FIG. 1A illustrates a standard prior art male DIN plug;

[0063] FIG. 1B illustrates a prior art female DIN receptacle for the male DIN plug shown in FIG. 1A;

[0064] FIG. 1C illustrates a plurality of standard prior art circular female DIN receptacles;

[0065] FIG. 2A illustrates a cross sectional diagram of a female DIN receptacle coupled with a corresponding male DIN plug, in accordance with an embodiment of the present specification;

[0066] FIG. 2B illustrates a cross sectional diagram of the female DIN receptacle of FIG. 2A without the male DIN plug, in accordance with an embodiment of the present specification;

[0067] FIG. 2C is a top view cross sectional diagrammatical representation of the female DIN receptacle of FIG. 2B;

[0068] FIG. 3A illustrates equipment comprising an amplifier for performing an EMG procedure on a patient; and

[0069] FIG. 3B illustrates amplifiers comprising female DIN receptacles, in accordance with an embodiment of the present specification;

[0070] FIG. 3C illustrates a close up view of the female DIN receptacles of the amplifier shown in FIG. 3B;

[0071] FIG. 3D illustrates a prior art male DIN plug that may be coupled with the male DIN receptacle of FIG. 3C, in accordance with an embodiment of the present specification; and

[0072] FIG. 3E is a top view cross sectional diagrammatical representation of a female DIN receptacle of FIG. 3C comprising 3 ball bearings, in accordance with an embodiment of the present specification.

DETAILED DESCRIPTION

[0073] In an embodiment, the present specification provides a high mating cycle circular female DIN connector receptacle. In some embodiments, the circular female DIN receptacle comprises one or more curved or beveled components which press against a housing hood of a corresponding compatible male DIN plug, generating friction for obtaining a greater retention force than that demonstrated by the prior art DIN connectors/receptacles. In various embodiments, the curved or beveled components comprise stainless

steel ball bearings. The greater retention force inhibits premature disengagement between a male DIN plug and female DIN receptacle.

[0074] In embodiments, the female DIN receptacle of the present specification can be used with any standard male DIN connector and is compatible with standardized male DIN plugs. In an embodiment, the female DIN receptacle of the present specification is used in amplifiers (2 and 12 channels) being used in conjunction with EMG equipment.

[0075] The present specification is directed towards multiple embodiments. The following disclosure is provided in order to enable a person having ordinary skill in the art to practice the invention. Language used in this specification should not be interpreted as a general disavowal of any one specific embodiment or used to limit the claims beyond the meaning of the terms used therein. The general principles defined herein may be applied to other embodiments and applications without departing from the spirit and scope of the invention. Also, the terminology and phraseology used is for the purpose of describing exemplary embodiments and should not be considered limiting. Thus, the present invention is to be accorded the widest scope encompassing numerous alternatives, modifications and equivalents consistent with the principles and features disclosed. For purpose of clarity, details relating to technical material that is known in the technical fields related to the invention have not been described in detail so as not to unnecessarily obscure the present invention. In the description and claims of the application, each of the words “comprise” “include” and “have”, and forms thereof, are not necessarily limited to members in a list with which the words may be associated.

[0076] It should be noted herein that any feature or component described in association with a specific embodiment may be used and implemented with any other embodiment unless clearly indicated otherwise.

[0077] FIG. 2A illustrates a cross sectional diagram of a female DIN connector receptacle **202** coupled with a corresponding male DIN plug **208**, in accordance with an embodiment of the present specification. FIG. 2B illustrates a cross sectional diagram of the female DIN connector receptacle **202** of FIG. 2A without the male DIN plug **208**, in accordance with an embodiment of the present specification. FIG. 2C is a top view cross sectional diagrammatical representation of the female DIN receptacle of FIG. 2B.

[0078] Referring to FIGS. 2A, 2B and 2C, the female DIN receptacle **202** comprises a circular housing **214** circumferentially surrounding a plug receptacle **220**. The plug receptacle **220** comprises a plurality of connectors **222** each of which is configured to receive a corresponding pin of the male DIN plug **208**. In embodiments, an internal surface of the circular housing **214** is separated from the plug receptacle **220** by a circular gap, well or cavity **207**. In some embodiments, the circular housing and the plug receptacle are molded such that they are connected with a gap incorporated therein, as described above.

[0079] In some embodiments, the female DIN receptacle **202** further comprises first and second protrusion members **204** positioned, respectively, in first and second gaps, spaces or notches within the circular housing **214**. In some embodiments, the first and second protrusion members **204** are positioned 180 degrees from each other (that is, diametrically opposite) around the circular housing **214**. In some

embodiments, the first protrusion member is a ball bearing. In some embodiments, the first and second protrusion members **204** are ball bearings.

[0080] As shown in FIGS. 2A, 2B and 2C, in some embodiments, the first and second protrusion members **204** are ball bearings which press against a housing hood **206** of the corresponding male DIN plug **208**, from two opposing sides, when the male DIN plug **208** and the female DIN receptacle **202** are mated. While two ball bearings **204** are depicted in FIG. 2A, one or more ball bearings, such as 2, 3, 4, 5, 6, 7, 8 or more distributed evenly around the circular housing **214** of the female DIN receptacle **202**, may be used in various embodiments of the present specification. In an embodiment, the ball bearings **204** are made out of stainless steel. In other embodiments, ball bearings of other suitable materials may also be used such as, but not limited to, chrome steel and ceramic (silicon nitride (Si_3N_4)).

[0081] In various embodiments, the ball bearings **204** are pressed against the housing hood **206** by using a spring force. Referring to FIG. 2B, the housing hood (**206** of FIG. 2A) of the male DIN plug **208** is inserted into the circular gap **207** for mating/connecting with the female DIN receptacle **202**. Also depicted is an opening **209** in the female DIN receptacle **202** for receiving a prong of the male DIN plug **208**.

[0082] In an embodiment, the spring force is achieved by using a circular retention band or an elastomeric O-ring **210**, wherein the retention band **210** presses against each of the ball bearings **204**. The circular retention band **210** is circumferentially positioned around an outside surface of the circular housing **214**. The retention band **210** is configured to physically force the first and second protrusion members **204** out of their respective first and second gaps and further into the circular gap **207**. In some embodiments, when the male DIN plug **208** is not inserted into the female DIN receptacle **202**, both the first and second protrusion members **204** are configured to be pressed against an outside surface of the plug receptacle **220** by the spring force provided by the retention band **210**. In some embodiments, when the male DIN plug **208** is inserted into the female DIN receptacle **202**, both the first and second protrusion members **204** are configured to be pressed against a surface of the male DIN plug **208**, such as the housing hood **206**, by the spring force provided by the retention band **210**.

[0083] As can be seen in FIGS. 2A, 2B and 2C, the ball bearings **204** contact the retention band **210** on one end and extend into the gap **207** on the other end to contact the housing hood **206** of the male DIN plug **208** (once inserted) for a secure fit. A first portion **204a** of the ball bearings **204** extends into the gap **207** to contact the housing hood **206** of the connector plug **208** when inserted, while a second portion **204b** of the ball bearings, opposite the first portion **204a**, contacts the compressible retention band **210**. When the housing hood **206** of the male DIN plug **208** is inserted into the female DIN receptacle **202**, the elastomeric retention band **210** applies pressure to the second portion **204b** of the ball bearings, causing the ball bearings to move laterally such that the first portion **204a** of the ball bearings contacts and applies a force to the housing hood **206**, providing a more secure connection between the male DIN plug **208** and female DIN receptacle **202**.

[0084] As shown in FIG. 2C, the circular gap **207** has an outer radius 'It' and an inner radius 'r' such that a width 'w' of the circular gap **207** is. In embodiments, the female DIN

receptacle **202** has a first state and a second state. In the first state, the ball bearings **204** are positioned within the circular gap **207** such that X % of the width 'w' of the circular gap **207** comprises a ball bearing. In the second state, the ball bearings **204** are positioned within the circular gap **207** such that Y % of the width 'w' of the circular gap **207** comprises a ball bearing. In embodiments, Y % is less than X % when the first state corresponds to the male DIN plug **208** not being inserted into the female DIN receptacle **202** whereas the second state corresponds to the housing hood **206** of the male DIN plug **208** being inserted into the female DIN receptacle **202**. Thus, in the first state the ball bearings are skewed radially towards a center 'C' of the female DIN receptacle **202** (as a result of being pushed by the retention band **210**) causing the ball bearings to occupy a higher percentage (X %) of the width 'w' of the circular gap **207**. However, in the second state the ball bearings are pushed radially away from the center 'C', by the inserted hood **206**, against the retention band **210** causing the ball bearings to occupy a lesser percentage (Y %) of the width 'w' of the circular gap **207**.

[0085] Stated differently, in the first state, the retention band **210** physically forces the first and second protrusion members **204** out of the respective first and second gaps and further into the circular gap **207** by a first distance. In the second state the retention band **210** physically force the first and second protrusion members **204** out of the respective first and second gaps and further into the circular gap **207** by a second distance. The second distance is less than the first distance when the second state is achieved by the male DIN plug **208** being inserted into the female DIN receptacle **202**.

[0086] In some embodiments, the retention band **210** has a durometer rating in a range of 50-90 Shore. In an embodiment, the retention band **210** is a high durometer and low compression set O-ring for providing the spring force for pressing the ball bearings **204** against the housing hood **206** of the male DIN plug **208**. The retention band **210** is placed in close contact with a ball bearing **204** in order to enable the retention band to press against the ball bearing, thereby creating friction and generating a large retention force between the male DIN plug **208** and the receptacle **202**. In some embodiments, approximately 3.68 lbs of force is required to remove a seated male DIN plug **208** from the female DIN receptacle **202**, compared to approximately 1.96 lbs of force in the prior art. The retention band **210** is contained within a molded enclosure wall **212** of the female DIN receptacle **202**, which also encloses a housing **214** of the female DIN receptacle **202**, in order to further enable the retention band **210** to exert a compression force rather than being allowed to expand as the ball bearings **204** are forced out of the gap **207** by the male DIN plug housing hood **206** during disconnection/un-mating.

[0087] In another embodiment, a circular spring may be used to generate friction between the ball bearings **204** and the male DIN plug housing hood **206**. The circular spring wraps around a center portion or plug receptacle **220** of the female DIN receptacle **202** and presses the ball bearing inward. In other words, a spring force is provided by wounding a circular spring around the center portion or plug receptacle **220** of the female DIN receptacle **202** for pushing

the first and the second ball bearings **204** against the housing of the male DIN plug **208**. In yet another embodiment, a coiled spring may be used to directly push the ball bearings **204** inward, for generating a retention force between the female DIN receptacle **202** and the male DIN plug **208**. Thus, in this embodiment, a spring force is provided by using a coiled spring to push the ball bearings **204** inwards towards the housing of the male DIN plug **208** when the male DIN plug **208** is connected to the female DIN receptacle **202**.

[0088] FIG. 3A illustrates an equipment cart **300** comprising an amplifier **305** for performing an EMG procedure on a patient. FIG. 3B illustrates amplifiers **304**, **305** comprising female DIN connector receptacles **306**, in accordance with an embodiment of the present specification. Referring to FIGS. 3A and 3B, the EMG equipment cart **300** comprises a mobile arm **302** holding the amplifier **305** comprising female DIN connector receptacles **306** for connecting with male DIN connector plugs (not shown in FIGS. 3A, 3B) coupled with electrodes (not shown in FIG. 3A, 3B) being used to monitor a patient's neural activity.

[0089] FIG. 3C illustrates a close-up view of the female DIN receptacles **306** of the amplifier **304** shown in FIG. 3B. FIG. 3D illustrates a male DIN plug **310** that may be coupled with any one of the female DIN receptacles **306** of FIG. 3C, in accordance with an embodiment of the present specification. FIG. 3E is a top view cross sectional diagrammatical representation of the female DIN receptacle **306** of FIG. 3C comprising first, second and third protrusion members **308**, in accordance with an embodiment of the present specification.

[0090] Referring to FIGS. 3C, 3D and 3E, each of the female DIN receptacles **306** comprises a circular housing **315** circumferentially surrounding a plug receptacle **320**. The plug receptacle **320** comprises a plurality of hollow connector volumes **322** each of which is configured to receive a corresponding pin of the male DIN plug **310**. In embodiments, an internal surface of the circular housing **315** is separated from the plug receptacle **320** by a circular gap, well or cavity **314**. In some embodiments, the circular housing and the plug receptacle are molded.

[0091] In some embodiments, each of the female DIN receptacles **306** further comprises first, second and third protrusion members **308** positioned, respectively, in first, second and third gaps, spaces or notches within the circular housing **315**. In some embodiments, the first, second and third protrusion members **308** are positioned 120 degrees from each other around the circular housing **315**. In some embodiments, the first, second and third protrusion members **308** are ball bearings.

[0092] In some embodiments, the first, second and third ball bearings **308** press against a housing hood **318** of the corresponding male DIN plug **310** when the male DIN plug **310** and the female DIN receptacle **306** are mated.

[0093] In an embodiment, a spring force is achieved by using a circular retention band or an elastomeric O-ring **312**, wherein the retention band **312** presses against each of the ball bearings **308**. The circular retention band **312** is circumferentially positioned around an outside surface of the circular housing **315**. The retention band **312** is configured to physically force the first, second and third protrusion members **308** out of their respective first, second and third gaps and further into the circular gap **314**. In some embodiments, when the male DIN plug **310** is not inserted into the

female DIN receptacle **306**, the first, second and third protrusion members **308** are configured to be pressed against an outside surface of the plug receptacle **320** by the spring force provided by the retention band **312**.

[0094] As shown in FIG. 3E, the circular gap **314** has an outer radius 'It' and an inner radius 'r' such that a width 'w' of the circular gap **314** is. In embodiments, each of the female DIN receptacles **306** has a first state and a second state. In the first state, the ball bearings **308** are positioned within the circular gap **314** such that X % of the width 'w' of the circular gap **314** comprises a ball bearing. In the second state, the ball bearings **308** are positioned within the circular gap **314** such that Y % of the width 'w' of the circular gap **314** comprises a ball bearing. In embodiments, Y % is less than X % when the first state corresponds to the male DIN plug **310** not being inserted into the female DIN receptacle **306** whereas the second state corresponds to the housing hood **318** of the male DIN plug **310** being inserted into the female DIN receptacle **306**. Thus, in the first state the ball bearings are skewed radially towards a center '0' of the female DIN receptacle **306** (as a result of being pushed by the retention band **312**) causing the ball bearings **308** to occupy a higher percentage (X %) of the width 'w' of the circular gap **314**. However, in the second state the ball bearings **308** are pushed radially away from the center '0', by the inserted hood **318**, against the retention band **312** causing the ball bearings **308** to occupy a lesser percentage (Y %) of the width 'w' of the circular gap **314**.

[0095] Stated differently, in the first state the retention band **312** physically forces the first, second and third protrusion members **308** out of the respective first, second and third gaps and further into the circular gap **314** by a first distance. In the second state the retention band **312** physically forces the first, second and third protrusion members **308** out of the respective first, second and third gaps and further into the circular gap **314** by a second distance. The second distance is less than the first distance when the second state is achieved by the male DIN plug **310** being inserted into the female DIN receptacle **306**.

[0096] In an embodiment, the ball bearings **308** are positioned approximately 1-3 mm from a top/opening surface of the female DIN receptacle **306**. The proximity of the ball bearings **308** to the top/opening surface of the female DIN receptacle **306** allows the user to start the connector engagement process with no physical resistance. When the male DIN plug **310** is not seated in the female DIN receptacle **306**, the ball bearings **308** are pushed-in toward the center '0' of the female DIN receptacle **306** (laterally), by the retention band **312**, into the circular gap or space **314** configured to receive the housing hood or shell **318** of the male DIN plug **310**.

[0097] Referring to FIGS. 3D and 3E, and similarly to the embodiment pictured in FIGS. 2A-2C, a first portion **308a** (proximal to the center '0' of the female DIN receptacle **306**) of the ball bearings **308** extends into the gap **314** to contact the housing hood **318** of the male DIN plug **310** when inserted, while a second portion **308b** (distal from the center '0' of the female DIN receptacle **306**) of the ball bearings **308**, opposite the first portion **308a**, contacts the compressible retention band **312**. When the housing hood **318** of the male DIN plug **310** is inserted into the female DIN receptacle **306**, the elastomeric retention band **312** applies pressure to the second portion **308b** of the ball bearings **308**, causing the ball bearings **308** to move laterally such that the

first portion **308a** of the ball bearings **308** contacts and applies a force to the housing hood **318**, providing a more secure connection between the male DIN plug **310** and the female DIN receptacle **306**.

[0098] In embodiments, the retention band **312** is stretched when positioned within the female DIN receptacle **306**, so that it is in a tense state. In some embodiments, a dimensional relationship exists between a diameter of the ball bearing **308** and the size of the gap/opening **314** in the female DIN receptacle **306** and/or the housing hood or shell **318** of the male DIN plug **310** (outer circular portion of the male DIN plug **310** that inserts into the female DIN receptacle **306**) to ensure that the male DIN plug **310** seats properly and securely within the female DIN receptacle **306**. The diameter of the ball bearing **308** is designed such that it is not too large or small. Too large of a diameter will not allow the ball bearing **308** to be pushed aside as the male DIN plug **310** is inserted and too small of a diameter will not allow the ball bearing **308** to cause friction/resistance to hold the male DIN plug **310** in place. In an embodiment, the male DIN plug **310** comprises a dip/recess **316** to accommodate the ball bearing **308** so that the male DIN plug **310** 'clicks' into place when seated in the female DIN receptacle **306** when the ball bearings **308** mate with the recess **316**.

[0099] In various embodiments, the number of ball bearings and/or durometer rating of the retention band may be changed to modulate the force required to remove the male DIN plug from the male DIN receptacle.

[0100] The above examples are merely illustrative of the many applications of the system of present specification. Although only a few embodiments of the present specification have been described herein, it should be understood that the present specification might be embodied in many other specific forms without departing from the spirit or scope of the specification. Therefore, the present examples and embodiments are to be considered as illustrative and not restrictive, and the specification may be modified within the scope of the appended claims.

1-20. (canceled)

21. A method of connecting a first electrical component to a second electrical component and detaching the first electrical component from the second electrical component, wherein the second electrical component has an end comprising a receptacle configured to receive an end of the first electrical component, comprising:

obtaining the first electrical component and the second electrical component;

aligning the end of the first electrical component with the receptacle of the second electrical component;

inserting the end of the first electrical component into the receptacle thereby causing a first protrusion member positioned at least partially in a space within the receptacle to move; and

removing the end of the first electrical component from the receptacle thereby causing the first protrusion member and a second member to move with respect to said space, wherein the second member is configured to cause the first protrusion member to be automatically moved at least partially outside said space when the end of the first electrical component is removed from said receptacle.

22. The method of claim **21**, wherein the receptacle comprises a housing defined by an exterior surface and an

interior surface and wherein the space is positioned between the exterior surface and the interior surface.

23. The method of claim **22**, wherein the second member is positioned circumferentially around the interior surface.

24. The method of claim **22**, wherein the second member is configured to physically force the first protrusion member out of the space.

25. The method of claim **22**, wherein the second member is positioned within a groove extending around the interior surface of the housing.

26. The method of claim **25**, wherein the second member is a retention band and the first protrusion member is a ball bearing.

27. The method of claim **22**, wherein the space comprises a first cavity and a second cavity, wherein the second cavity is separate and distinct from the first cavity, wherein the first protrusion member is positioned at least partially in the first cavity and a second protrusion member is positioned at least partially in the second cavity.

28. The method of claim **27**, wherein the second member is configured to physically force the second protrusion member out of the second cavity.

29. The method of claim **27**, wherein the first protrusion member and the second protrusion member are positioned 180 degrees from each other on opposite sides of the housing.

30. The method of claim **27**, wherein the first protrusion member is a ball bearing, the second protrusion member is a ball bearing, and both the first protrusion member and second protrusion member are configured to be pressed against an outside surface of the end of the first electrical component by a spring force provided by the second member.

31. The method of claim **22**, wherein the space comprises a first cavity, a second cavity separate and distinct from the first cavity, and a third cavity separate and distinct from the first cavity and the second cavity, wherein the first protrusion member is positioned at least partially in the first cavity, a second protrusion member is positioned at least partially in the second cavity, and a third protrusion member is positioned at least partially in the third cavity.

32. The method of claim **31**, wherein the second member is configured to physically force the second protrusion member out of the second cavity and the third protrusion member out of the third cavity.

33. The method of claim **32**, wherein the first protrusion member, the second protrusion member, and the third protrusion member are positioned 120 degrees from each other circumferentially around the housing.

34. The method of claim **21**, wherein the end of the first electrical component comprises a plug comprising a plurality of pins and wherein the receptacle of the second component comprises a plurality of connectors each configured to receive one of the plurality of pins of the plug.

35. The method of claim **21**, wherein the receptacle is a female DIN connector receptacle.

36. The method of claim **32**, wherein the end of the first electrical component is a male DIN connector plug.

37. The method of claim **21**, wherein the receptacle is configured to connect EMG electrodes with an EMG control system via an amplifier.

38. The method of claim **21**, wherein the second member is a retention band and the first protrusion member is a ball bearing.

39. The method of claim **21**, wherein the receptacle is molded.

40. The method of claim **21**, wherein the second member is an O-ring having a durometer rating in a range of 50 to 90 Shore.

* * * * *