



US 20180310971A1

(19) **United States**

(12) **Patent Application Publication**  
**NARDINI**

(10) **Pub. No.: US 2018/0310971 A1**

(43) **Pub. Date: Nov. 1, 2018**

(54) **SELF CENTERING FEATURE FOR AN INTRAMEDULLARY NAIL**

*A61B 17/68* (2006.01)

*A61B 17/17* (2006.01)

(71) Applicant: **DePuy Synthes Products, Inc.**,  
Raynham, MA (US)

(52) **U.S. Cl.**

CPC ..... *A61B 17/8057* (2013.01); *A61B 17/8052*  
(2013.01); *A61B 17/7233* (2013.01); *A61B*  
*17/7241* (2013.01); *A61B 17/863* (2013.01);  
*A61B 17/68* (2013.01); *A61B 17/1725*  
(2013.01); *A61B 17/725* (2013.01)

(72) Inventor: **Reto NARDINI**, Oberdorf (CH)

(21) Appl. No.: **16/026,933**

(22) Filed: **Jul. 3, 2018**

(57)

**ABSTRACT**

An intramedullary nail includes a body sized and shaped for insertion into a medullary canal of a bone and extending along a longitudinal axis from a proximal end to a distal end and a channel extending through the body along the longitudinal axis in combination with a locking hole extending laterally through the body along a central axis and in communication with the channel, the locking hole defined by a first opening extending through a first portion of a wall of the nail and a second opening extending through a second portion of the wall substantially opposing the first portion, the first opening being elongated in a lateral direction relative to the longitudinal axis of the nail and the second opening including a coupling element configured to lock a portion of a bone fixation element therein.

**Related U.S. Application Data**

(62) Division of application No. 13/647,834, filed on Oct. 9, 2012, now Pat. No. 10,039,582.

(60) Provisional application No. 61/577,991, filed on Dec. 20, 2011.

**Publication Classification**

(51) **Int. Cl.**

*A61B 17/80* (2006.01)

*A61B 17/72* (2006.01)

*A61B 17/86* (2006.01)

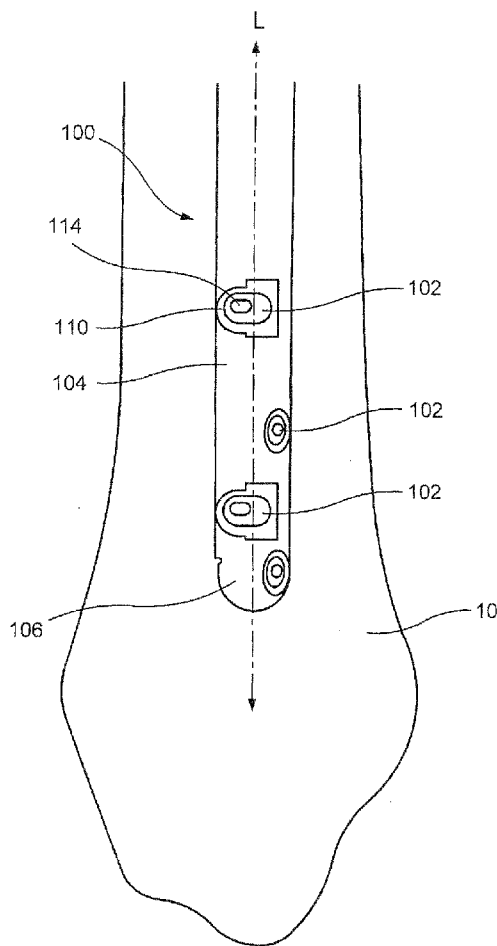

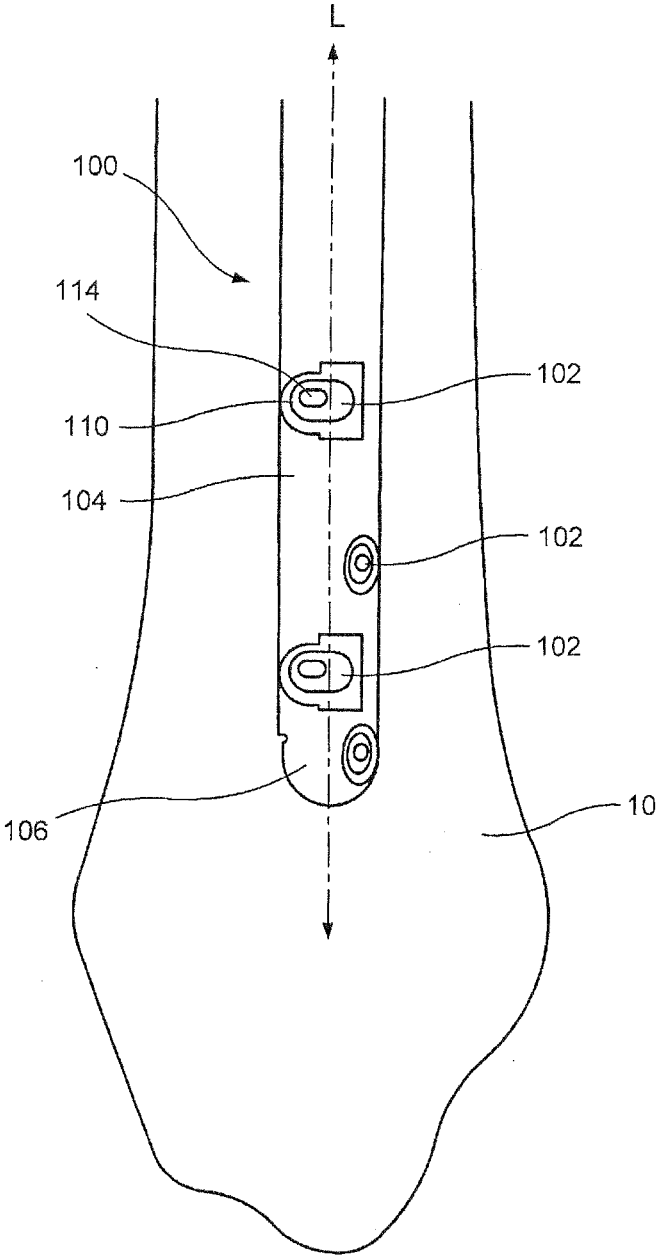

FIG. 1

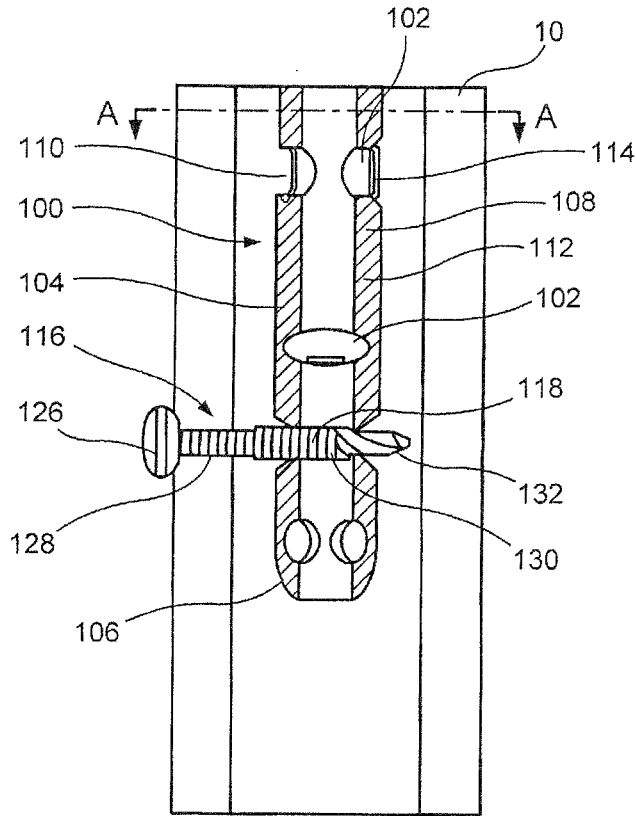

FIG. 2

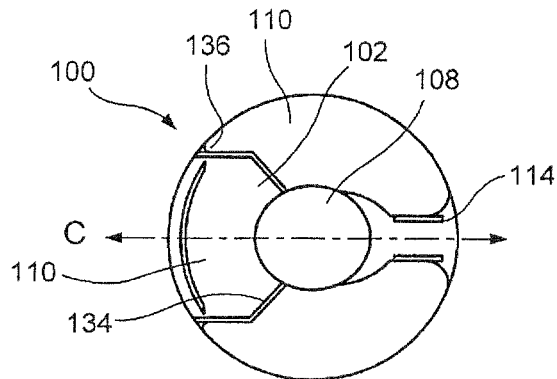

FIG. 3

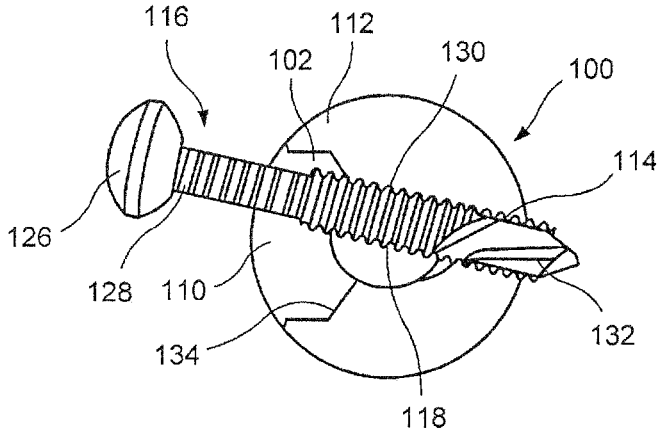

FIG. 4

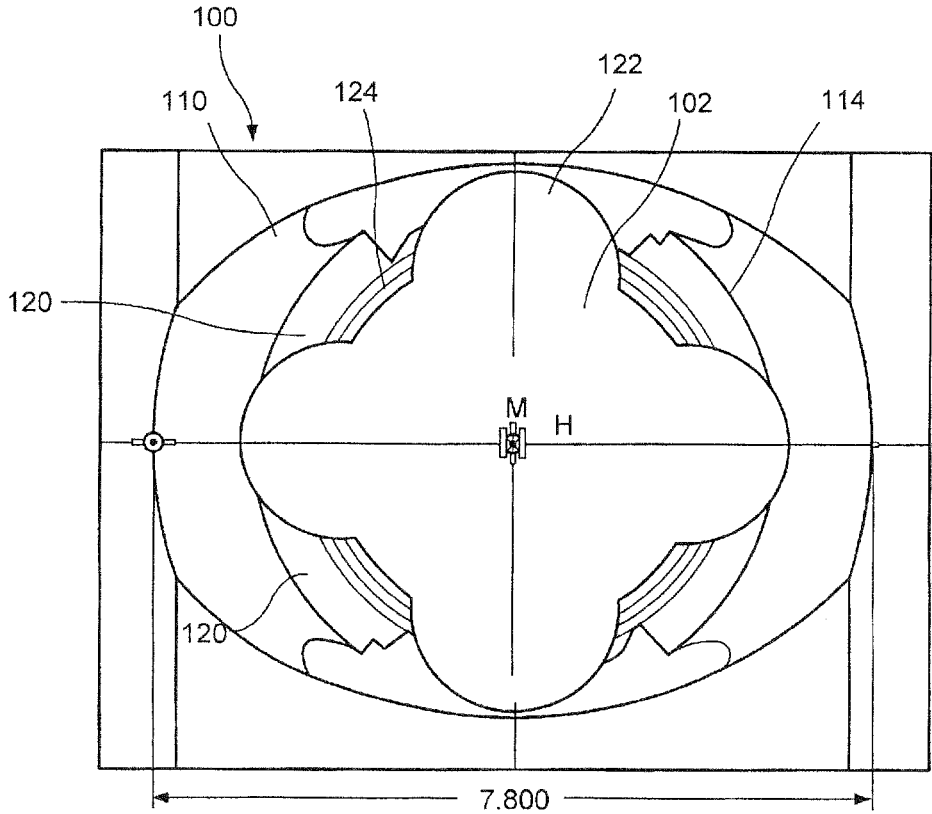

FIG. 5

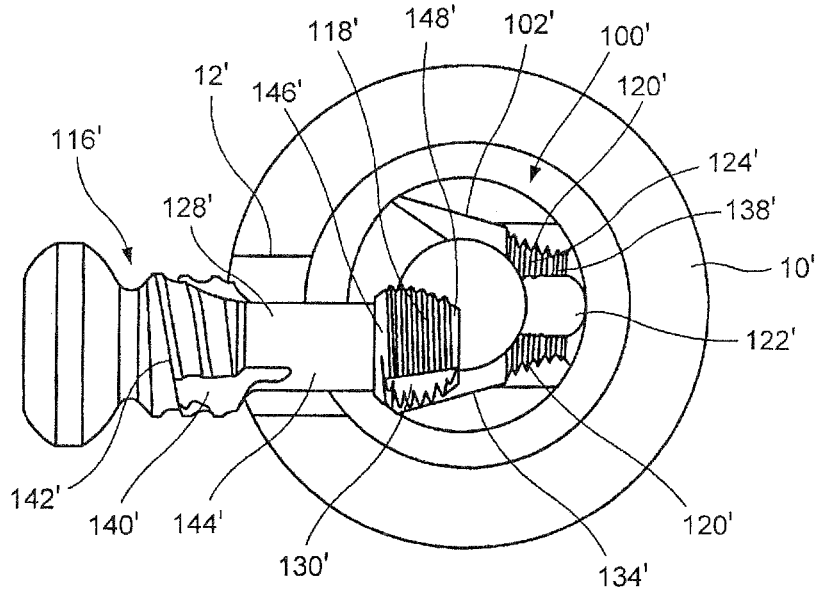

FIG. 6

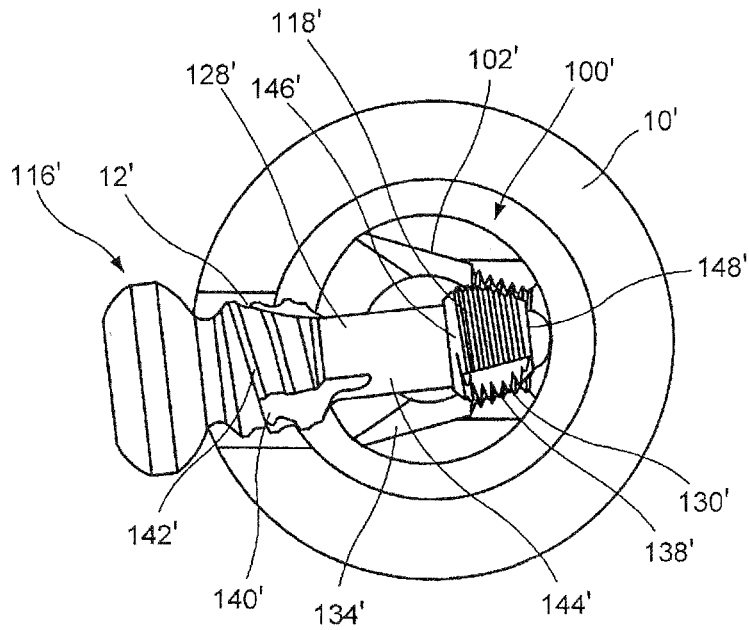

FIG. 7

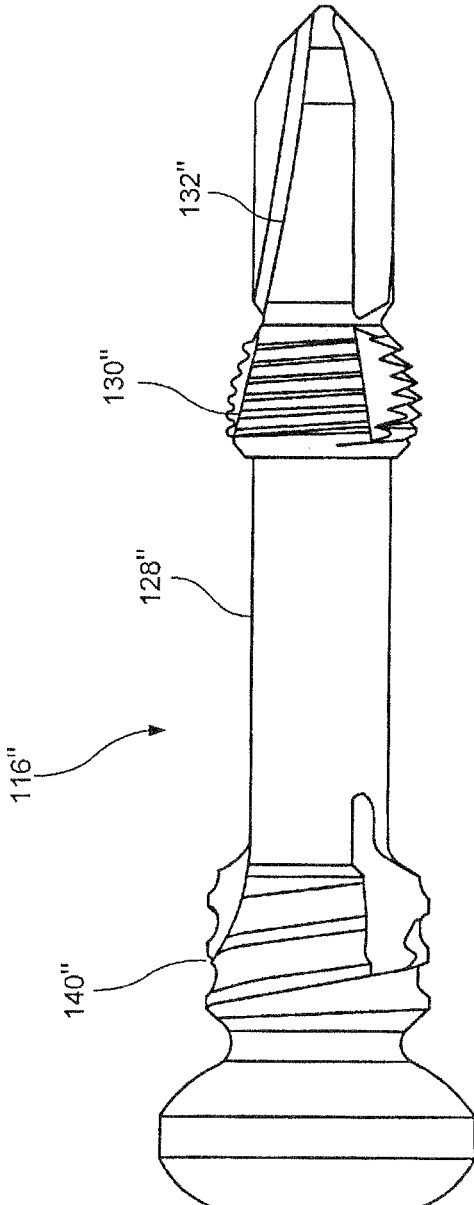

FIG. 8

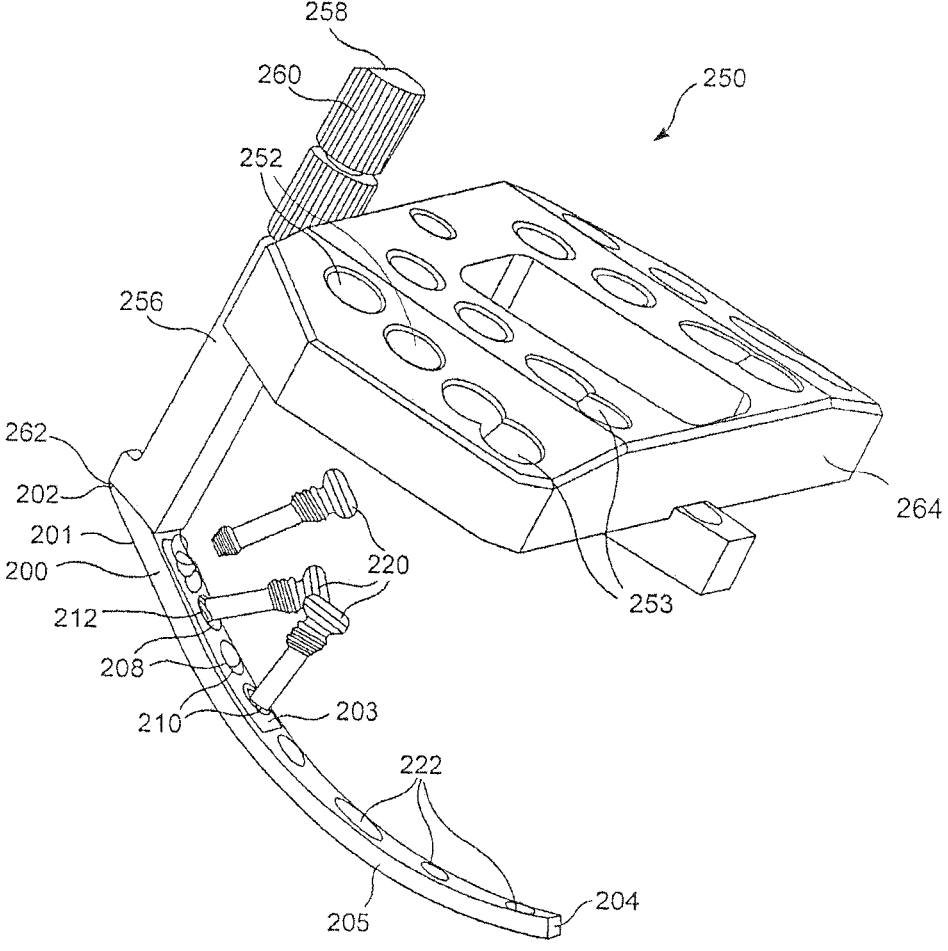

FIG. 9

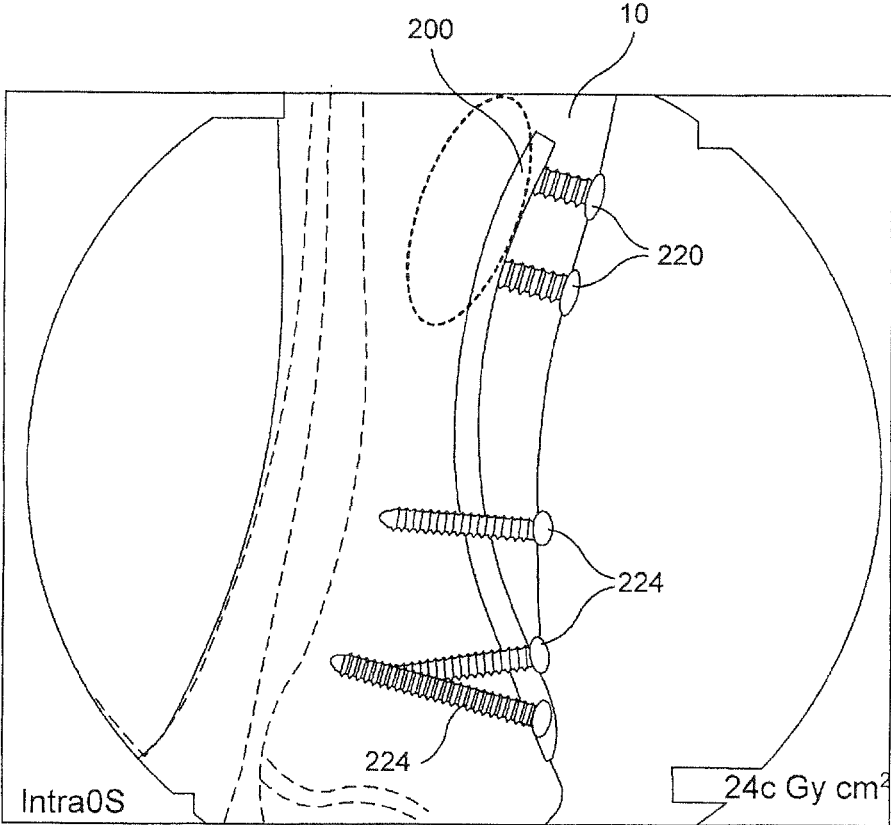

FIG. 10



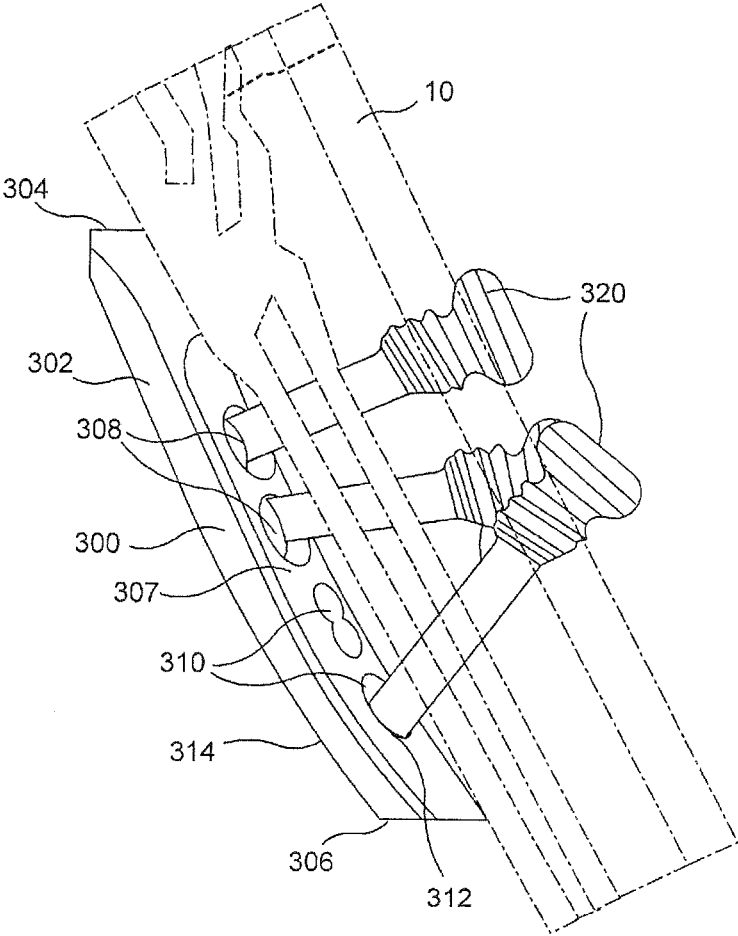

FIG. 11

## SELF CENTERING FEATURE FOR AN INTRAMEDULLARY NAIL

### PRIORITY CLAIM

[0001] The present application claims priority to U.S. Provisional Application Ser. No. 61/577,991 entitled "Self Centering Feature for an Intramedullary Nail" filed on Dec. 20, 2011, the entire disclosure of which is incorporated herein by reference.

### BACKGROUND

[0002] Intramedullary nails are inserted into the medullary canals of long bones to stabilize these bones (e.g., to fix fractures thereof) and may include locking holes extending laterally through distal and proximal portions thereof to fix a nail at a desired position within the bone. An aiming arm may be attached to a proximal end of an intramedullary nail to aid in locating positions of the proximal and distal locking holes to guide the drilling of holes through the bone to permit the insertion of locking screws into the locking holes. Due to the natural curvature of the medullary canal, however, an intramedullary nail may bend as it is inserted moving distal locking holes out of alignment with the aiming holes in the aiming arm.

### SUMMARY OF THE INVENTION

[0003] The present invention is directed to an intramedullary nail, comprising a body sized and shaped for insertion into a medullary canal of a bone and extending along a longitudinal axis from a proximal end to a distal end and a channel extending through the body along the longitudinal axis in combination with a locking hole extending laterally through the body along a central axis and in communication with the channel, the locking hole defined by a first opening extending through a first portion of a wall of the nail and a second opening extending through a second portion of the wall substantially opposing the first portion, the first opening being elongated in a lateral direction relative to the longitudinal axis of the nail and the second opening including a coupling element configured to lock a portion of a bone fixation element therein.

### BRIEF DESCRIPTION OF THE DRAWINGS

[0004] FIG. 1 shows a side view of a distal portion of an intramedullary nail according to an exemplary embodiment of the present invention;

[0005] FIG. 2 shows a longitudinal cross-sectional view of the distal portion of the intramedullary nail of FIG. 1;

[0006] FIG. 3 shows a lateral cross-sectional view of the intramedullary nail of FIG. 1, along line A-A;

[0007] FIG. 4 shows a lateral cross-sectional view of the intramedullary nail of FIG. 1, along line A-A, with a bone fixation element extending through a locking hole thereof;

[0008] FIG. 5 shows an enlarged side view of the distal portion of the intramedullary device of FIG. 1;

[0009] FIG. 6 shows a lateral cross-sectional view of an intramedullary nail and a bone fixation element being inserted into a locking hole thereof according to a further embodiment of the present invention;

[0010] FIG. 7 shows a lateral cross-sectional view of the intramedullary nail of FIG. 6, with the bone fixation element engaging the locking hole;

[0011] FIG. 8 shows a side view of a bone fixation element according to another embodiment of the present invention;

[0012] FIG. 9 shows a side view of an intramedullary plate according to another embodiment of the invention;

[0013] FIG. 10 shows a cross-sectional view of the intramedullary plate of FIG. 9 after implantation into a bone; and

[0014] FIG. 11 shows a partial see-through view of a bone plate according to yet another embodiment of the invention.

### DETAILED DESCRIPTION

[0015] The present invention may be further understood with reference to the following description and the appended drawings, wherein like elements are referred to with the same reference numerals. The present invention relates to the stabilization of bones and, in particular, to the stabilization of a long bone (e.g., a fractured bone) using an intramedullary nail. Exemplary embodiments of the present invention describe an intramedullary nail including a distal locking hole configured such that a bone fixation element may be inserted therethrough even when the nail is bent as a result of insertion in a medullary canal of a bone. In particular, a first one of the distal locking hole extends along a central axis from a first opening in a near wall of the intramedullary nail to a second opening in a far wall. The first opening is laterally elongated so that a bone fixation element may be inserted through the locking hole at an angle with respect to the central axis. It should be noted that the terms "proximal" and "distal" as used herein, are intended to refer to a direction toward (proximal) and away from (distal) a user of the device.

[0016] An intramedullary nail **100** according to an exemplary embodiment of the present invention shown in FIGS. 1-5 comprises a locking hole **102** extending through a distal portion **104** thereof. The intramedullary nail **100** is sized and shaped for insertion in to a medullary canal of a bone **10** and extends along a longitudinal axis **L** from a proximal end (not shown) to a distal end **106** with a channel **108** extending therethrough along the longitudinal axis **L**. The locking hole **102** extends laterally through the distal portion **104** along a central axis **C** which, in an exemplary embodiment, is substantially perpendicular to the longitudinal axis **L**. The locking hole **102** extends from a first opening **110** in a first portion of a wall **112** (e.g., along a near wall) of the nail **100** to a second opening **114** in a second portion of the wall **112** (e.g., along a far wall) substantially diametrically opposed to the first portion of the wall **112**. The first and second openings **110**, **114** are sized and shaped to permit a bone fixation element **116** to be inserted therethrough, from the first opening **110** to the second opening **114**, at an angle with respect to the central axis **C** such that the bone fixation element **116** may be inserted therethrough even when the bone fixation element **116** is inserted misaligned with the central axis **C** due, for example, to bending of the nail **100** as it conforms to the shape of the bone into which it has been inserted. In particular, the first opening **110** is elongated in a direction transverse to the longitudinal axis **L** of the nail **100** to permit the bone fixation element **116** to be inserted therethrough even when it is angled with respect to the central axis **C**. The second opening **114** is configured to engage a portion of the bone fixation element **116** therein. When the intramedullary nail **100** is bent laterally with respect to the longitudinal axis of the nail **100**, as it conforms to the path of the medullary canal, the user may rely on the

aiming hole in the aiming handle to drill a hole and insert the bone fixation element **116** so long as the axis of the aiming hole passes through the elongated portion of the first opening **110**. That is, as the deformation of the nail **100** moves the first opening **110** substantially laterally the position of the first opening **110** along the longitudinal axis of the nail **100** is known and the elongated shape of the first opening **110** compensates for the lateral misalignment.

[0017] It will be understood by those of skill in the art that a conventional aiming arm or any other known aiming device/method may be utilized to determine a position of the locking hole **102** along a length of the nail **100**. For example, a conventional aiming arm end of the nail **100** includes at least one aiming hole extending therethrough (and, preferably, one aiming hole for each bone fixation element to be inserted laterally through the nail **100**). The aiming hole is positioned to be precisely aligned with the locking hole **102** prior to distortion of the nail **100** during insertion into a bone **10**. As the bending of the distal portion **104** of the nail **100** is substantially lateral with respect to the longitudinal axis of the nail **100**, the aiming hole still substantially indicates a position of the locking hole **102** along a length of the nail **100** even after the nail **100** has been inserted into the bone **10**. A hole corresponding in position and direction to the aiming hole drilled into a near cortex of the bone **10** permits the bone fixation element **116** to be inserted into the locking hole **102** via the corresponding hole in the bone **10**. The corresponding hole in the bone **10** may be overdrilled (e.g., drilled such that a diameter thereof is slightly larger than a desired diameter of the bone fixation element) to increase the chance of the bone fixation element **116** finding the elongated first opening **110**.

[0018] The first opening **110** is elongated in a direction substantially perpendicular to the longitudinal axis **L** such that the bone fixation element **116** may be inserted therethrough even when the distal portion **104** of the nail **100** is bent. The first opening **110** according to this embodiment of the invention also includes a sharp edge **136** to facilitate cutting through any bone-ingrowth if, in the future, the intramedullary nail **100** must be removed from the bone **10**. The first opening **110** may also include an angled interior surface **134** angled to guide a bone fixation element **116** inserted into the first opening **110** toward the second opening **114**. The first opening **110** is sized to provide a desired range of possible movement of the bone fixation element therein. For example, a first opening **110** having a width (e.g., a distance between lateral ends) of approximately 7.8 mm will permit a bone fixation element **116** to be inserted therethrough within a range of about 7 mm.

[0019] The second opening **114** is sized, shaped and configured to receive and lock a portion of the bone fixation element **116**. The second opening **114** according to this embodiment includes a coupling element permitting a portion of the bone fixation element **116** to be locked therein even when the bone fixation element **116** extends therethrough at an angle with respect to the central axis **C**. The second opening **114** may, for example, be configured as a variable angle hole which engages threads **118** of the bone fixation element **116** even when the bone fixation element **116** is angled with respect to the central axis **C**. For example, the second opening **114** may include a plurality of columns **120** separated from one another about a circumference of the opening **114** and extending radially inward therefrom. Each of the columns **120** is separated from adjacent columns via

scalloped portions **122** which extend radially outward therefrom. In one exemplary embodiment, the columns **120** are spaced substantially equidistantly from one another about a circumference of the second opening **114**. The columns **120** include protrusions **124** such as, for example, threads or spikes, extending therefrom to engage the threading **118** of the bone fixation element **116**. Each of the columns **120** according to this embodiment includes a surface curving and/or tapering radially inward permitting the protrusions **124** to engage the threads **118** while the bone fixation element **116** is inserted along an axis at any angle (within a permitted range of angulation) relative to the central axis **C** of the locking hole **102**. For example, the bone fixation element **116** may be inserted through the locking hole **102** at an angle up to 15° relative to the central axis **C**.

[0020] In one particular embodiment, as shown in FIGS. 6-7, protrusions **124'** are formed in columns **120'** along a second opening **114'** of a locking hole **102'**. The protrusions **124'** are formed as parts of a thread **138'** which, if connected across scalloped portions **122'** of the second opening **114'**, would form a single helical thread **138'** extending thereabout. Thus, as described above, a bone fixation element **116'** may be inserted through the locking hole **102'** at an angle relative to a central axis **C'** thereof. In particular, an enlarged distal portion **130'** of the bone fixation element **116'** may contact an angled surface **134'** of the first opening **110'** such that the distal portion **130'** of the bone fixation element **116'** is guided toward the second opening such that threading **118'** therealong engages the thread **138'** of the second opening **114'**.

[0021] Although the exemplary embodiment specifically describes a variable angle hole, it will be understood by those of skill in the art that the second opening **114** and/or bone fixation element **116** may include coupling elements other than the variable angle hole described above so long as the coupling element permits the bone fixation element **116** to extend therethrough at an angle with respect to the central axis **C**. For example, in another embodiment, the bone fixation **116** may be cannulated such that a wire may be received therein. The wire may include an enlarged distal end such that when the wire is pulled proximally relative to the bone fixation element **116**, the enlarged distal end is received within the cannulation, causing a portion of the bone fixation element **116** to expand radially outward and engage an inner surface of the locking hole **102**.

[0022] In one embodiment, as shown in FIGS. 2 and 4, the bone fixation element **116** includes a head portion **126** and a shaft **128** extending distally therefrom. The shaft **128** includes an enlarged distal portion **130** with a self-drilling tip **132** at a distal end thereof and threading **118** extending therealong. The self-drilling tip **132** may include blades extending therealong for cutting a bone as it is inserted into the bone. A length of the bone fixation element **116** is selected so that the threading **118** along the enlarged distal portion **130** engages the coupling element (e.g., protrusions **124** of a variable angle hole) of the second opening **114**. Thus, the bone fixation element **116** provides monocortical fixation of the intramedullary nail **100** such that it may be desired to utilize at least three bone fixation elements **116** to fix the intramedullary nail **100** to the bone **10**.

[0023] Thus, the intramedullary nail **100** may include a plurality of locking holes **102** extending through the distal portion **104** spaced apart from one another along a length of the nail **100** and angled with respect to one another about the

longitudinal axis L. In a preferred embodiment, the intramedullary nail 100 may include at least three locking holes 102 extending through the distal portion 104. Each of the locking holes 102 is configured to receive a bone fixation element 116, as described above.

[0024] In cases in which a hole is drilled in the bone, the self-drilling tip 132 is not required. In another embodiment, as shown in FIGS. 6 and 7, a bone fixation element 116' may be substantially similar to the bone fixation element 116 except that it does not include the self-drilling tip 132 and further includes an enlarged proximal portion 140' along a shaft 128' thereof in addition to an enlarged distal portion 130'. The enlarged distal portion 130' tapers from a proximal end 146' to a distal end 148' thereof and may have a curved exterior surface such that threads 118' extending therealong engage the protrusions 124' as the bone fixation element 116' is inserted through the locking hole 102' at an angle relative to the central axis C'. The enlarged proximal portion 140' is sized to engage a hole 12' drilled in a bone 10' and includes threading 142' therealong for engaging the drilled hole. The enlarged proximal portion 140' is separated from the enlarged distal portion 130' along the shaft 128' via an unthreaded middle portion 144' having a smaller diameter than both the proximal and distal portions 140', 130'. Although the bone fixation element 116' is specifically shown and described as being inserted into the locking hole 102, it will be understood by those of skill in the art that either of the bone fixation elements 116, 116' may be utilized for either of the holes 102, 102'.

[0025] In another embodiment, as shown in FIG. 8, a bone fixation element 116" is substantially similar to the bone fixation elements 116' described above, comprising a shaft 128" including a threaded proximal portion 140" separated from a threaded distal portion 130" by an unthreaded middle portion 144". The bone fixation element 116", however, also comprises a self-drilling tip 132" substantially similar to the self-drilling tip 132 of the bone fixation element 116. The self-drilling tip 132" may include blades extending therealong for cutting a bone as it is inserted into the bone. It will be understood by those of skill in the art that the bone fixation element 116" may be utilized in either of the locking holes 102, 102' described above.

[0026] According to an exemplary surgical technique of the present invention, an intramedullary nail 100 is inserted into the medullary canal of the bone 10. A conventional aiming arm or other aiming device is coupled to the nail 100 to facilitate the locating of the locking hole 102 (i.e., an axis of an aiming hole extends along the central axis C). Using the aiming hole as a guide, a hole is drilled into the near cortex of the bone 10 and the bone fixation element 116 is inserted into the corresponding hole in the bone 10 and into the enlarged first opening 110. As the bone fixation element 116 is inserted through the locking hole 102, a distal end thereof contacts the angled interior surface 134 such that the bone fixation element 116 is guided through the second opening 114 at an angle relative to the central axis C, within the permitted range of angulation. The threading 118 along the enlarged portion 130 engages the protrusions 124, or other coupling element, of the second opening 114, fixing the bone fixation element within the locking hole 102. The above-described process may be repeated for each of the remaining locking holes 102 extending through the nail 100. As discussed above, either of the bone fixation elements

116', 116" may be inserted into the locking hole 102 in place of the bone fixation element 116.

[0027] FIGS. 9-10 depict an intramedullary bone plate 200 according to another embodiment of the invention. The intramedullary bone plate 200 is formed substantially similarly to the intramedullary nail 100 except as noted below. The intramedullary plate 200 is sized and shaped for insertion into a medullary canal of a bone 10 and extends along an arcuate path from a proximal end 202 to a distal end 204. However, unlike the intramedullary nail 100, a cross-sectional shape of the intramedullary plate 200 is substantially rectangular, with substantially smooth edges to minimize trauma to the bone, as those skilled in the art will understand. It is noted, however, that other cross-sectional shapes are envisioned within the scope of the invention. The proximal end 202 is configured to removably engage an aiming arm 250 to aid in insertion of bone fixation elements 220 into the intramedullary plate 200, as will be described in greater detail later on. Specifically, the proximal end 202 may include an opening (not shown) configured to permit insertion of a threaded locking mechanism 256 extending through a handle 254 of the aiming arm 250. Specifically, the handle 256 extends from a first end 258 having a knob 260 connected to an elongated shaft (not shown) to a second end 262 having an opening (not shown) configured for alignment with the proximal opening (not shown) of the plate 200. In an operative configuration, the second end 262 is aligned with the proximal opening (not shown) of the plate 200 and rotated to cause the shaft (not shown) to extend out of the second end 262 and into the proximal opening. At least a portion of the shaft (not shown) may be threaded to engage corresponding threads of the proximal opening (not shown). It is noted, however, that other engagement means are envisioned within the scope of the invention, including, but not limited to a friction-fit engagement.

[0028] A proximal portion 201 of the intramedullary plate 200 is fitted with an insert 203 having a plurality of locking holes 208 extending therethrough. Specifically, the insert 203 is positioned over a recess (not shown) formed on a side wall of the plate 200, the recess having a thickness smaller than a thickness of the plate 200. The insert 203 is dimensioned so that, when positioned over the recess, an outer wall of the insert 203 lies flush with an outer wall of the plate 200, as shown in FIG. 9. Thus, the locking holes 208 extending through the insert 203 terminate at the plate 200 so that the bone fixation element 220 inserted therethrough does not extend through the plate 200 and out of an opposing wall thereof. Rather, the locking holes 208 are closed at their distal ends by a wall of the plate 200. Each of the locking holes 208 extends from a first opening 210 in a first portion of a wall 212 (e.g., along a near wall) to a second opening (not shown) terminating within the bone plate 200. As those skilled in the art will understand, this configuration prevents a bone fixation element 220 inserted through the locking hole 208 from extending through the intramedullary plate 200 and entering the far cortex. The locking hole 208 includes threading configured to threadedly engage threading 118, 118', 130" of the bone fixation element 220, as described in greater detail in earlier embodiments. The insert 203 may be integrally formed with the plate 200 or may be attached thereto using any known attachment means.

[0029] In an alternate embodiment, each of the locking holes 208 may extend along a locking hole axis C substantially perpendicular to a longitudinal axis of the intramed-

ullary plate **200** at the point at which the hole **208** passes through the plate **200** (i.e., a line tangent to the arc of the plate **200** at the hole **208**). Each of the first openings **210** and the second openings (not shown) is sized and shaped to permit a bone fixation element **220** to be inserted therethrough at an angle with respect to the central axis **C** such that the bone fixation element **220** may be inserted therethrough even if the bone fixation element **220** is misaligned with the central axis **C**.

**[0030]** The bone fixation element **220** is formed substantially similarly to the bone fixation element **116'** described earlier. A length of the bone fixation element **220** is selected to precisely correspond to a distance from the near cortex to the second opening (not shown) after implantation. The first opening **210** is elongated in a direction transverse to the longitudinal axis **L** of the plate **200** to permit the bone fixation element **220** to be inserted therethrough even when angled with respect to the central axis **C**. The second opening (not shown) is configured to engage a portion of the bone fixation element **220** therein. The second opening (not shown) is substantially similar to the second opening **114** and is sized, shaped and configured to receive and lock a portion of the bone fixation element **220**. Specifically, the second opening **114** includes a coupling element permitting a portion of the bone fixation element **220** to be locked therein even when the bone fixation element **220** extends therethrough at an angle with respect to the central axis **C**. The second opening (not shown) may, for example, be configured as a variable angle hole which engages threads **118** of the bone fixation element **220** or may include a plurality of columns separated of ridges from one another about a circumference of the second opening by scalloped portions which extend radially outward therefrom, as described in greater detail in earlier embodiments. In this embodiment, a guide plate **262** of the aiming arm **250** may also comprise a variable angle hole **253** to aid in alignment with the indicated locking hole **208**.

**[0031]** The intramedullary plate **200** may also comprise a plurality of additional locking holes **222** in a distal portion **205** thereof. The locking holes **222** are arranged at various angles relative to one another and have geometries selected to permit engagement thereof with bone fixation screws **224**. The locking holes **222** may be substantially similar to any of the locking holes **102**, **208** disclosed herein.

**[0032]** According to an exemplary surgical technique of the present invention, the intramedullary plate **200** is inserted into the medullary canal of the bone **10**. The aiming arm **250** is coupled to the plate **200** to facilitate locating the locking holes **208**. Using the aiming holes **252**, **253** as a guide, a hole is drilled into the near cortex of the bone **10** and the bone fixation element **220** is inserted into the corresponding hole in the bone **10** and into the enlarged first opening **210**. A bone fixation element **220** having a length corresponding to a distance from the near cortex of the bone to the second opening (not shown) of a selected locking hole **208** is inserted through the locking hole **208**, a distal end thereof contacting an angled interior surface of the locking hole **208** (not shown) such that the bone fixation element **220** is guided to the second opening (not shown) at an angle relative to the central axis **C**, within the permitted range of angulation. The above-described process may be repeated for each of the remaining locking holes **208** extending through the plate **200**. The plate **200** according to the invention is configured so that, when bent laterally with

respect to the longitudinal axis **L** as it conforms to the path of the medullary canal, the user may rely on the aiming hole **252**, **253** in the aiming arm **250** to drill a hole and insert the bone fixation element **220** so long as the axis of the aiming hole **252**, **253** passes through the elongated portion of the first opening **210**. The exemplary plate **200** according to the invention is particularly suited for insertion into the distal tibia which has a substantially oval cross-section. The substantially rectangular cross-sectional shape of the plate **200** is therefore well-suited for insertion into the distal tibia. The bone fixation element **220** is inserted into the locking hole **208** until a distal end thereof contacts the proximal portion **201** of the bone plate **200**, wherein the distal end may be substantially blunt and/or angled to maximize a contacting surface are thereof with the proximal portion **201**. Insertion of the bone fixation elements **220** against the intramedullary plate **200** also provides a stable interface therewith. Furthermore, by locking the bone fixation element **220** relative to the intramedullary plate **200**, there is no possibility of the bone fixation element **220** damaging soft tissue, organs, etc. at an opposing wall of the bone, as may be experienced with certain bicortical systems.

**[0033]** FIG. **11** depicts a device according to another embodiment of the invention and includes a bone plate **300** configured for placement over the far cortex in combination with bone fixation elements **320** inserted through the near cortex. The bone plate **300** includes an elongate body **302** extending from a first end **304** to a second end **306**, dimensions thereof being selected to conform to the requirements of a particular procedure. An insert **307** is positioned over a proximal portion of the bone plate **300** and includes a plurality of locking holes **308** extending therethrough from a first opening **310** on a first wall **312** positioned over the far cortex in an operative configuration to a second opening (not shown) on a second wall (not shown) positioned over the proximal portion of the bone plate **300**. Similar to the bone plate **200**, the insert **307** prevents the bone fixation element **320** inserted through the locking hole **308** from exiting out of the plate **300** and into the body. That is, a second wall **314** of the bone plate **300** is substantially smooth with no openings. The locking holes **308** are substantially similar to the locking holes **102**, **208** described earlier and are dimensioned to lockingly engage threads of the bone fixation element **320** even when the bone fixation element **320** is angled with respect to a central axis **C** thereof. Thus, the bone fixation elements **320** inserted through the insert **307** are prevented from being inserted through the proximal portion of the bone plate **300**. The bone fixation element **320** is also formed substantially similar to the bone fixation elements **116**, **220** described above.

**[0034]** In accordance with an exemplary surgical technique according to the invention, the first wall **312** is positioned over the far cortex of a target portion of the bone via a minimally invasive incision and provisionally secured thereto using a method known in the art. An imaging technique known in the art may then be used to aid in insertion of bone fixation elements **320** into the near cortex and through the bone to align with a selected one of the locking holes **308**. When treating smaller bones (e.g., bones of the hand, etc.), a surgeon or other user may have direct access to the near cortex and may manually guide the insertion of the bone fixation elements **320** into the bone. As described in greater detail earlier, a length of each of the bone fixation elements **320** is determined prior to insertion

conforming to a total distance from the near cortex to the second opening (not shown) of the locking hole **308**. The bone fixation element **320** is then inserted into the bone until a head thereof is seated over the bone and threads (not shown) provided at a distal end thereof lockingly engage threads of the locking hole **308**. As those skilled in the art will understand, not having the bone plate **300** placed on the near cortex prevents disturbance thereof after implantation given the thin layer of soft tissue covering the near cortex. This thin layer of tissue over the near cortex prevents the placement of a conventional bone plate and screw thereover. The exemplary system and method of the invention provides increased freedom in plate and screw placement and further biomechanically optimizes plate placement to a region having the least lever arm.

**[0035]** It will be apparent to those skilled in the art that various modifications and variations can be made in the structure and the methodology of the present invention without departing from the spirit or scope of the invention. Thus, it is intended that the present invention cover the modifications and variations of this invention provided that they come within the scope of the appended claims and their equivalents.

**1-30.** (canceled)

**31.** A bone screw, comprising:

a head; and

a shaft extending distally from the head along a longitudinal axis, the shaft including an enlarged distal portion with a threading extending thereabout to engage an opening of a bone fixation device at an angle within a permitted range of angulations relative to a central axis of the opening.

**32.** The bone screw of claim **31**, wherein the shaft includes an enlarged proximal portion separated from the enlarged distal portion by an unthreaded middle portion having a smaller diameter than the enlarged proximal and distal portions, the enlarged proximal portion having a threading extending thereabout to engage a hole drilled in a bone.

**33.** The bone screw of claim **31**, further comprising a self-drilling tip extending distally from the enlarged distal portion.

**34.** The bone screw of claim **31**, wherein the enlarged distal portion one of tapers from a proximal end to a distal end thereof and includes a curved exterior surface.

**35.** A bone plate, comprising:

a body sized and shaped for placement over a target portion of a bone and extending along a longitudinal axis from a proximal end to a distal end; and

a locking hole extending laterally through the body along a central axis, the locking hole defined by a first opening extending through a first portion of a wall of the nail and a second opening extending through a second portion of the wall substantially opposing the first portion, the first opening being elongated in a lateral direction relative to the longitudinal axis of the nail and the second opening including a coupling element configured to lock a portion of a bone fixation element therein.

**36.** The bone plate of claim **35**, wherein the locking hole extends through an insert provided on a first wall of the body, the insert being configured so the locking hole is only open at the first opening.

**37.** The bone plate of claim **35**, wherein the central axis of the locking hole is substantially perpendicular to the longitudinal axis of the nail.

**38.** The bone plate of claim **35**, wherein the first opening includes an interior surface angled to guide a bone fixation element toward the second opening.

**39.** The bone plate of claim **35**, wherein the first opening is elongated substantially perpendicularly of the longitudinal axis.

**40.** The bone plate of claim **35**, wherein the second opening is a variable angle hole including a plurality of columns separated from one another and extending radially inward, the columns including protrusions extending therealong to engage a threading along a bone fixation element that is inserted through the locking hole at an angle within a permitted range of angulations relative to the central axis.

**41.** A method for treating a bone, comprising:

positioning a bone plate over a target portion of a far cortex of a bone, the bone plate including a body extending along a longitudinal axis from a proximal end to a distal end and having a locking hole extending laterally therethrough along a central axis, the locking hole defined by a first opening extending through a first portion of a wall of the nail and a second opening extending through a second portion of the wall substantially opposing the first portion, the first opening being elongated in a lateral direction relative to the longitudinal axis of the nail and the second opening including a coupling element configured to lock a portion of a bone fixation element therein;

drilling a hole into a near cortex of the bone to correspond to a position of the locking hole; and

inserting a bone fixation element through the hole in the near cortex of the bone and into the first opening such that a threaded portion of the first bone fixation element is guided into the second opening to engage the coupling element and lock the bone fixation element therein at an angle within a permitted range of angulations relative to the central axis.

**42.** The method of claim **41**, wherein the bone fixation element is guided into the second opening via an angled interior surface of the first opening.

**43.** A system for bone fixation, comprising:

a plate body sized and shaped for placement at a first target location of a bone, the plate body extending along a longitudinal axis from a proximal end to a distal end; and

a locking hole extending laterally through the body along a central axis;

a bone fixation element including a head, a shaft and a threaded portion, the bone fixation element being insertable through a second target location of the bone separated from the first target location and aligned with the central axis so that the threaded portion engages threading of the locking hole at the first target location.

**44.** The system of claim **43**, wherein the locking hole is defined by a first opening extending through a first portion of a wall of the nail and a second opening extending through a second portion of the wall substantially opposing the first portion, the first opening being elongated in a lateral direction relative to the longitudinal axis of the nail and the second opening including a coupling element configured to lock a portion of a bone fixation element therein.

45. The system of claim 43, wherein the first target location is a medullary canal and the plate is an intramedullary plate.

46. The system of claim 43, wherein the first target location is the far cortex.

\* \* \* \* \*