



(19) **United States**

(12) **Patent Application Publication**
Powers et al.

(10) **Pub. No.: US 2018/0311488 A1**

(43) **Pub. Date: Nov. 1, 2018**

(54) **ASSEMBLIES FOR IDENTIFYING A POWER INJECTABLE ACCESS PORT**

A61M 39/00 (2006.01)

A61M 5/32 (2006.01)

A61M 5/158 (2006.01)

A61M 5/162 (2006.01)

(71) Applicant: **Bard Peripheral Vascular, Inc.**,
Tempe, AZ (US)

(52) **U.S. Cl.**

CPC . *A61M 39/0208* (2013.01); *A61M 2039/0238* (2013.01); *A61B 6/481* (2013.01); *A61M 5/007* (2013.01); *A61M 39/04* (2013.01); *A61M 2039/0063* (2013.01); *A61M 2039/0054* (2013.01); *A61M 2039/0045* (2013.01); *A61M 2039/0009* (2013.01); *A61M 2005/325* (2013.01); *A61M 2005/1581* (2013.01); *A61M 5/3273* (2013.01); *A61M 5/162* (2013.01); *A61M 5/158* (2013.01); *A61M 2039/0072* (2013.01); *A61M 2039/0205* (2013.01); *Y10T 428/139* (2015.01); *A61M 2205/32* (2013.01); *A61B 6/12* (2013.01)

(72) Inventors: **Kelly B. Powers**, North Salt Lake, UT (US); **Jim C. Beasley**, Houston, TX (US); **Guy T. Rome**, Herriman, UT (US)

(21) Appl. No.: **16/029,103**

(22) Filed: **Jul. 6, 2018**

Related U.S. Application Data

(62) Division of application No. 14/748,917, filed on Jun. 24, 2015, now Pat. No. 10,016,585, which is a division of application No. 14/455,660, filed on Aug. 8, 2014, now Pat. No. 9,937,337, which is a division of application No. 12/419,854, filed on Apr. 7, 2009, now Pat. No. 8,805,478, which is a division of application No. 11/380,124, filed on Apr. 25, 2006, now Pat. No. 8,545,460.

(60) Provisional application No. 60/737,466, filed on Nov. 15, 2005, provisional application No. 60/675,309, filed on Apr. 27, 2005.

Publication Classification

(51) **Int. Cl.**

A61M 39/02 (2006.01)

A61B 6/12 (2006.01)

A61B 6/00 (2006.01)

A61M 5/00 (2006.01)

A61M 39/04 (2006.01)

(57)

ABSTRACT

A method of power injecting a contrast medium into a patient, including obtaining a power-injectable access port suitable for power injection. The power injectable access port includes a housing defining a reservoir, and a septum. The septum may include a self-sealing material, and a radiopaque material. The radiopaque material may form a selected pattern when an x-ray is taken through the septum for identifying the power-injectable access port as being suitable for power injection. The power-injectable access port may be structured for accommodating a pressure developed within the reservoir of at least 35 psi, and may be designed to accommodate a fluid flow rate of at least 1 milliliter per second. After implanting the power-injectable access port in the patient, the method may include imaging the power-injectable access port and confirming via the selected pattern in the septum that the power-injectable access port is suitable for injecting the contrast medium.

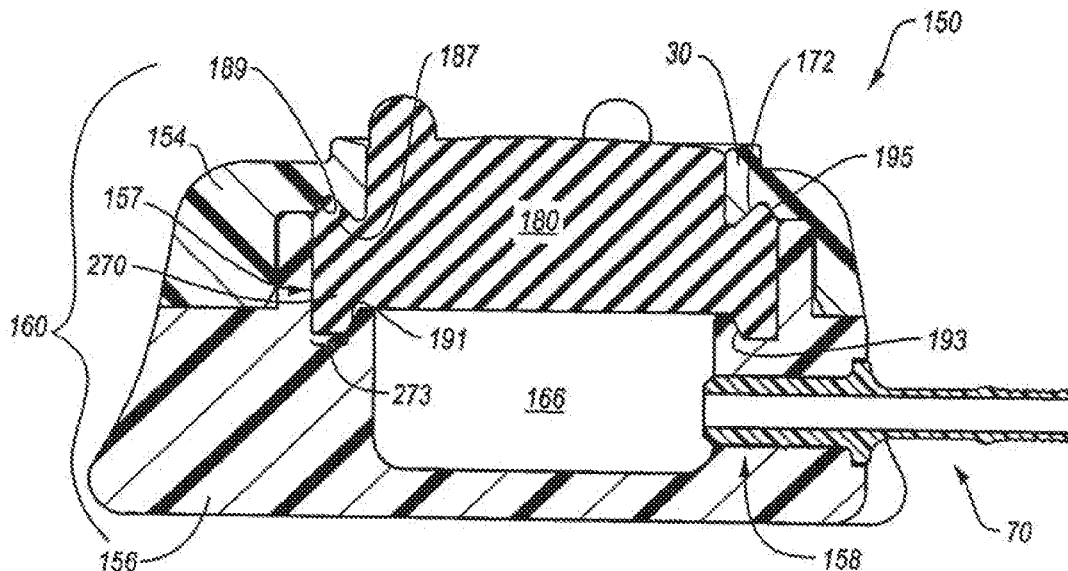

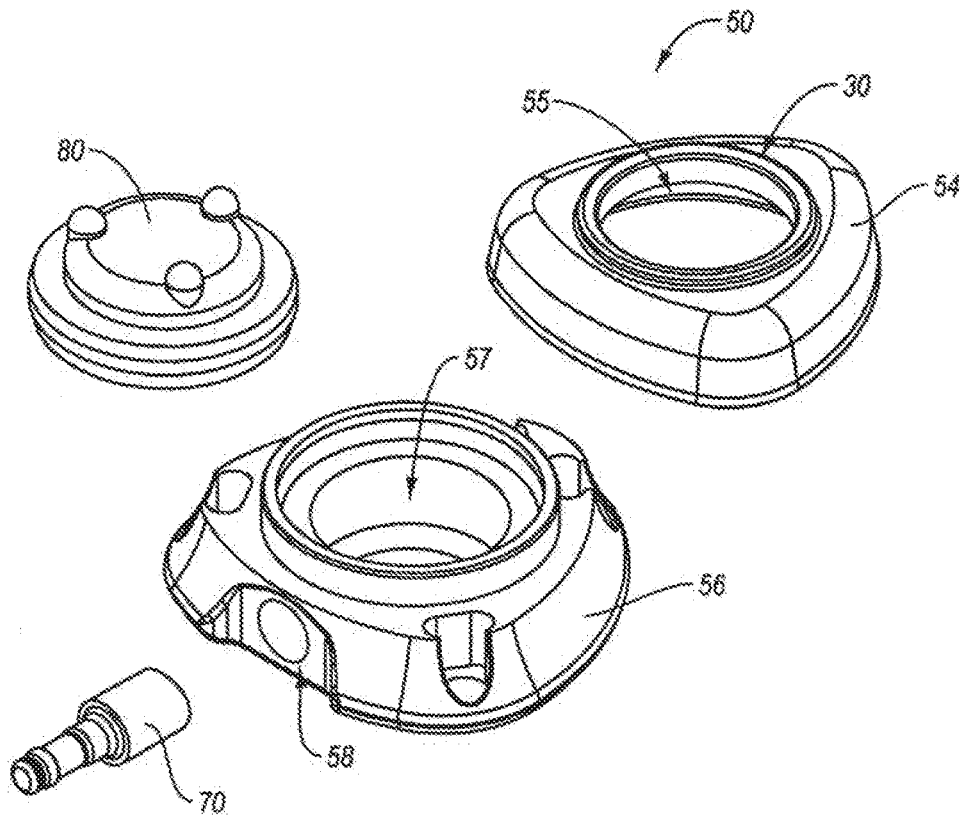

FIG. 1

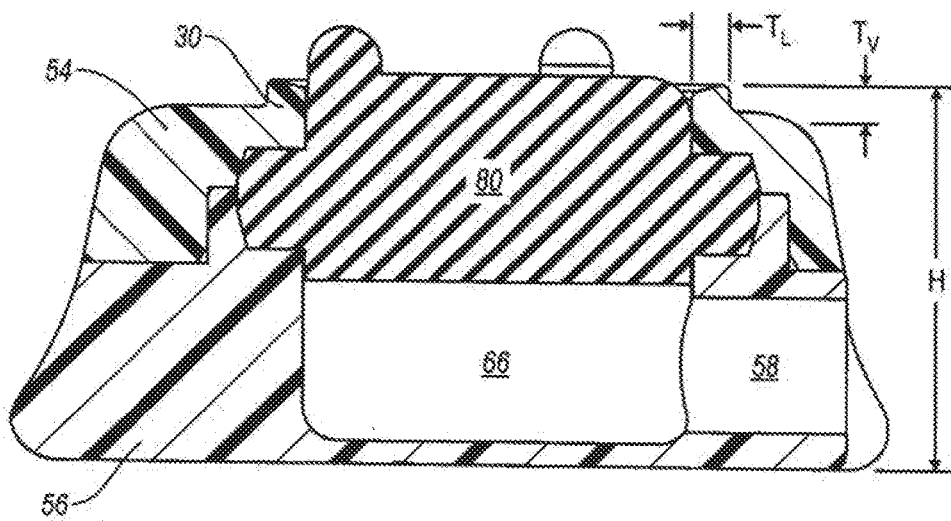

FIG. 2

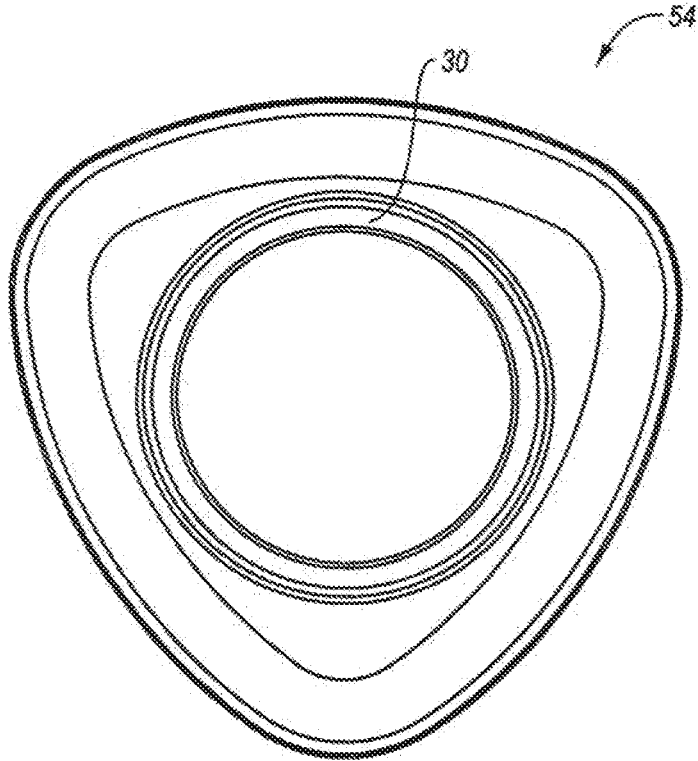

FIG. 3

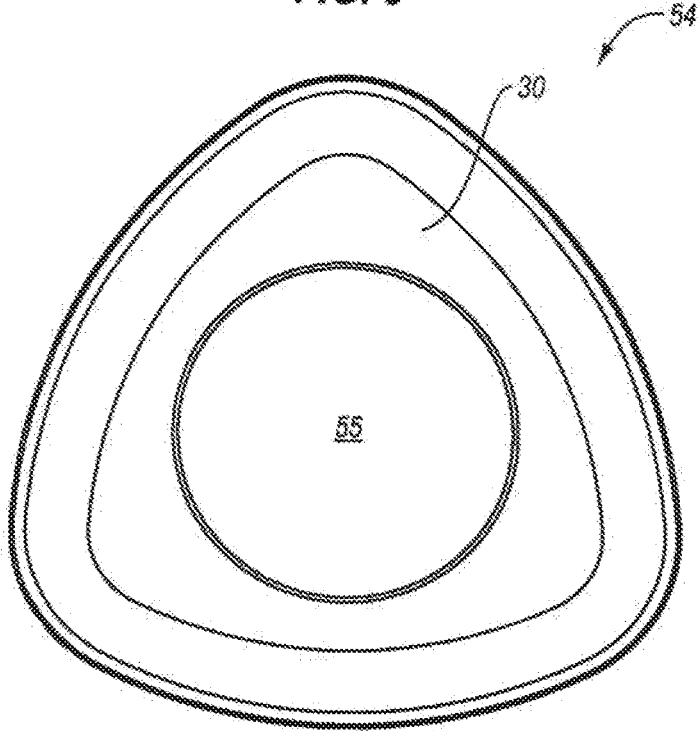

FIG. 4

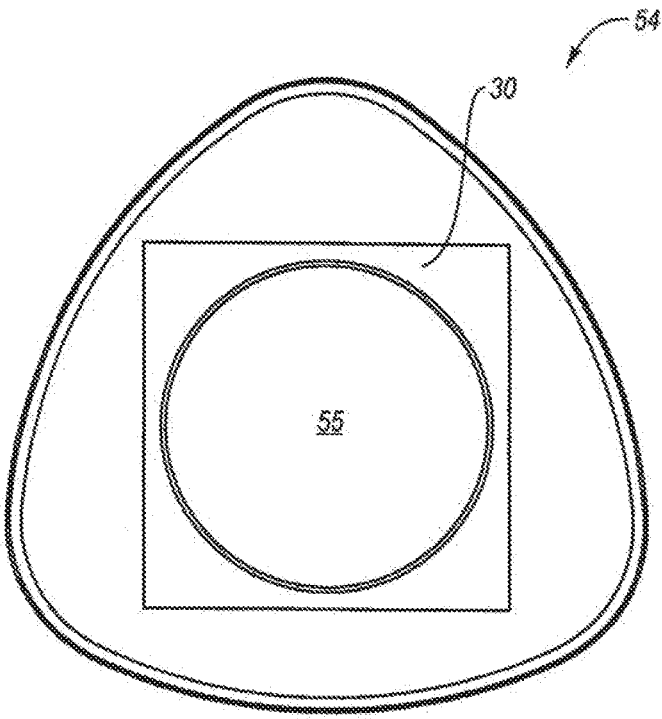

FIG. 5

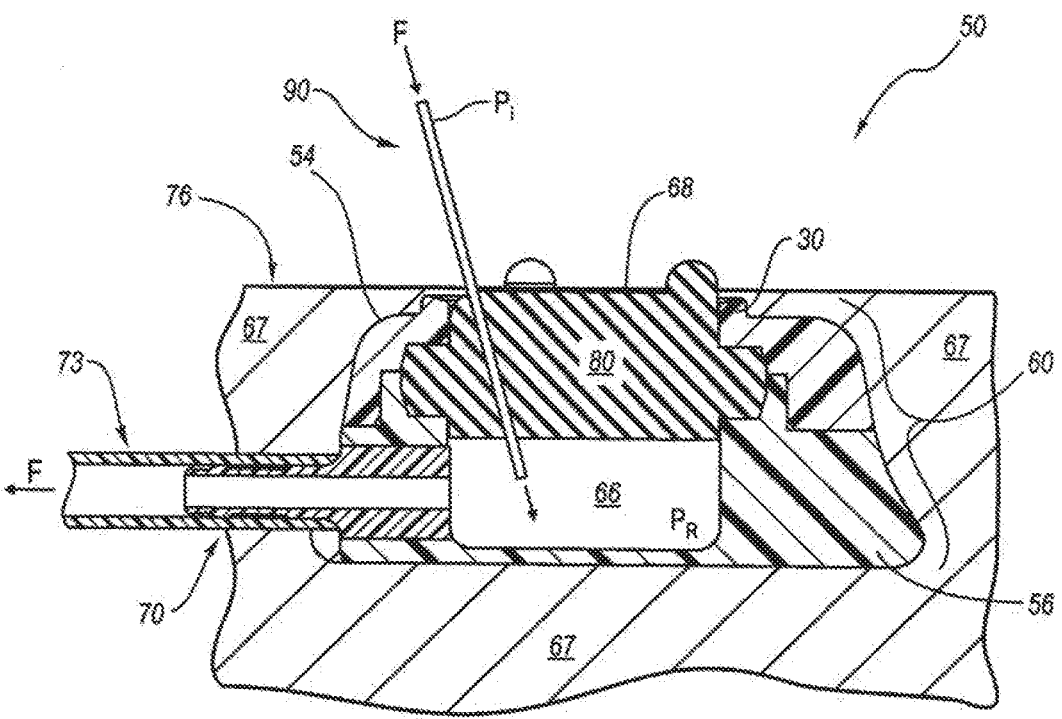

FIG. 6

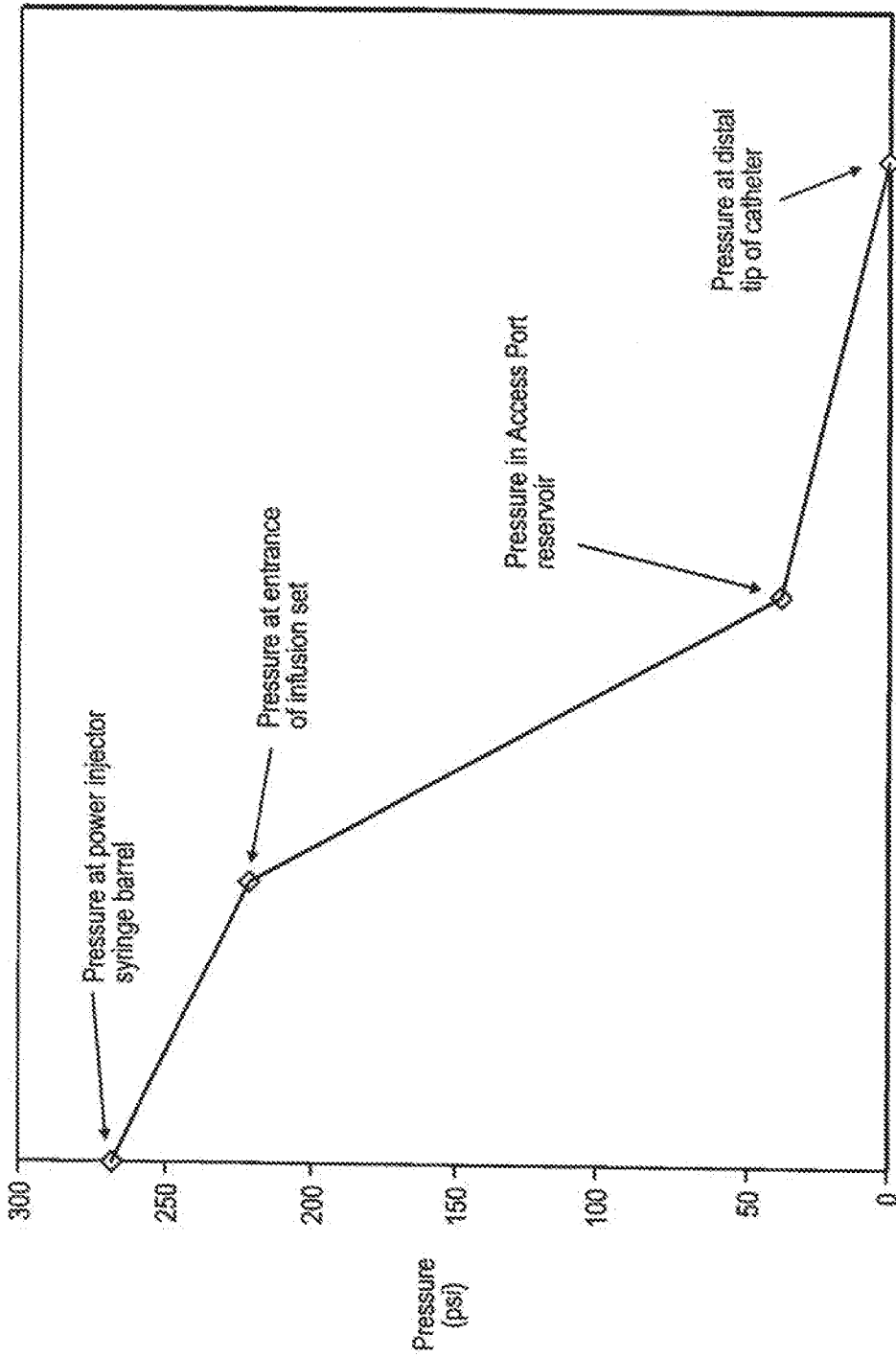

FIG. 7

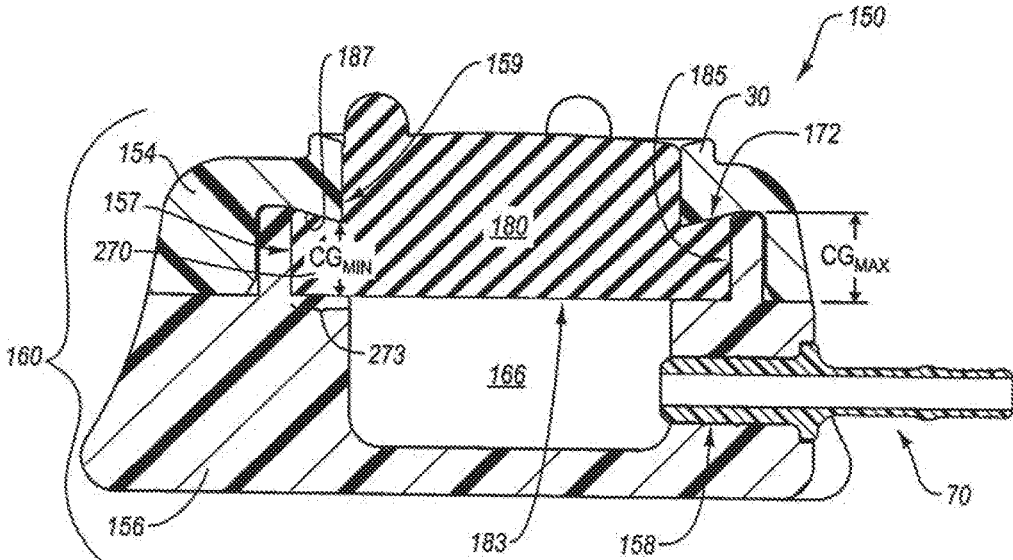

FIG. 8

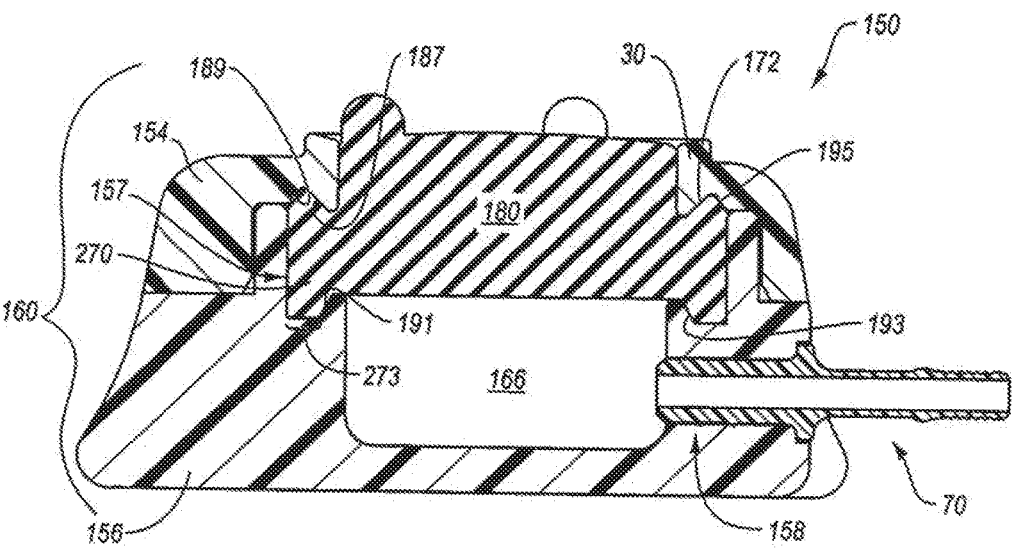

FIG. 9

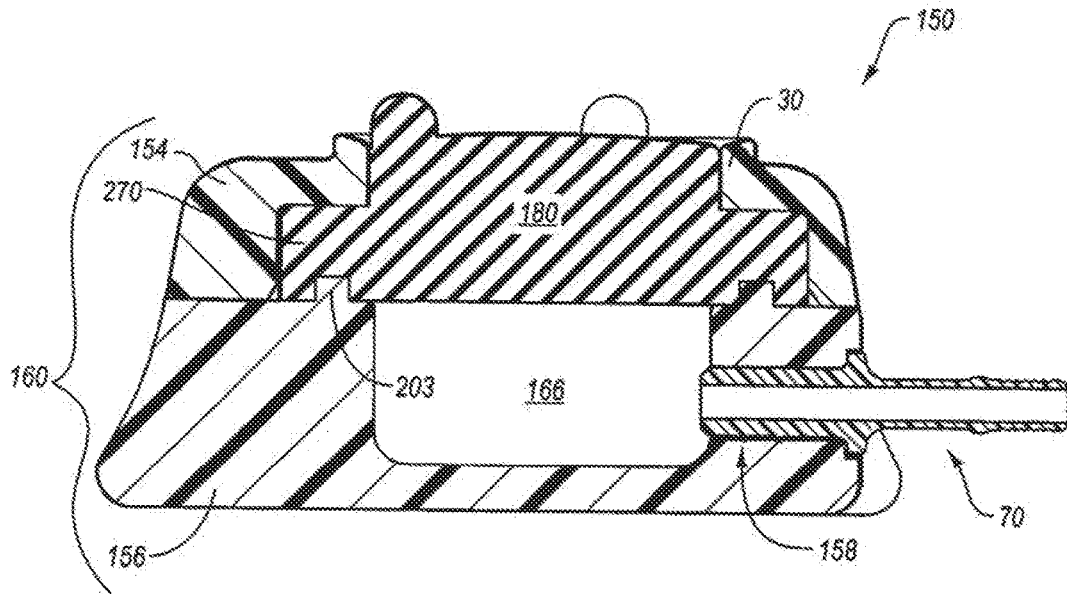

FIG. 10

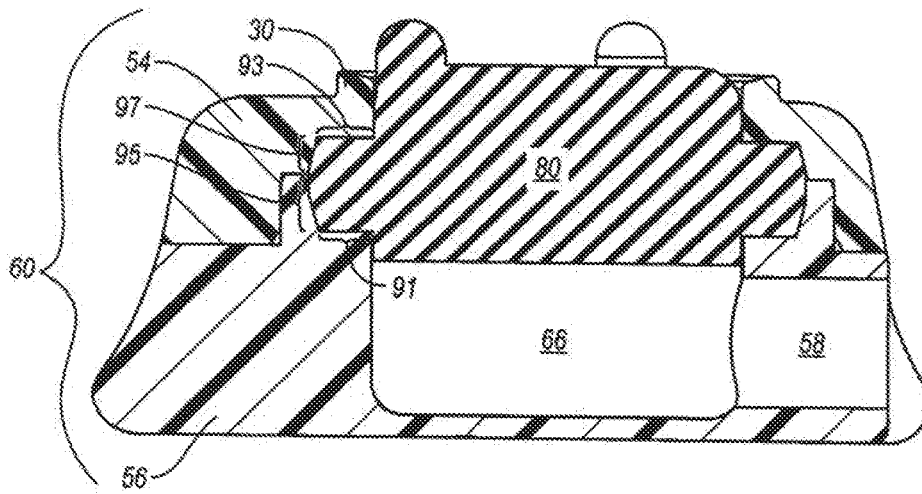

FIG. 11

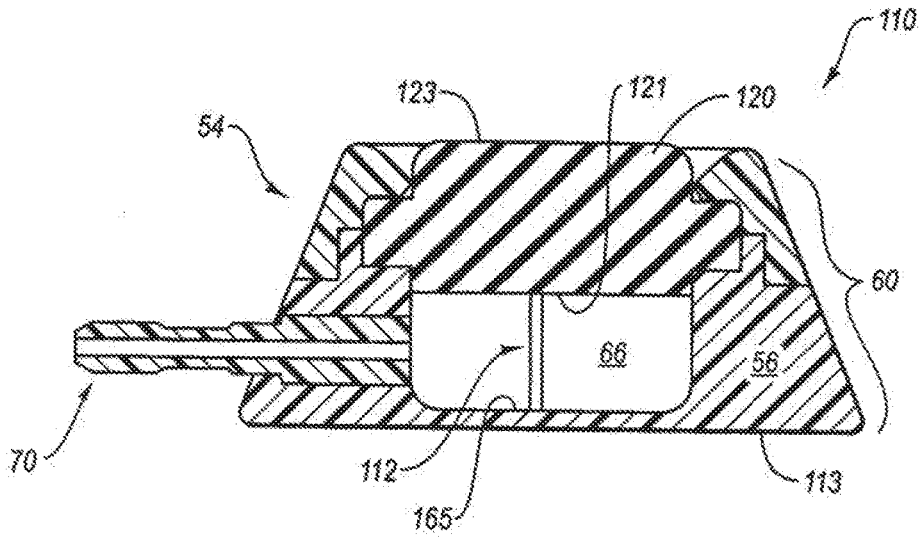

FIG. 12

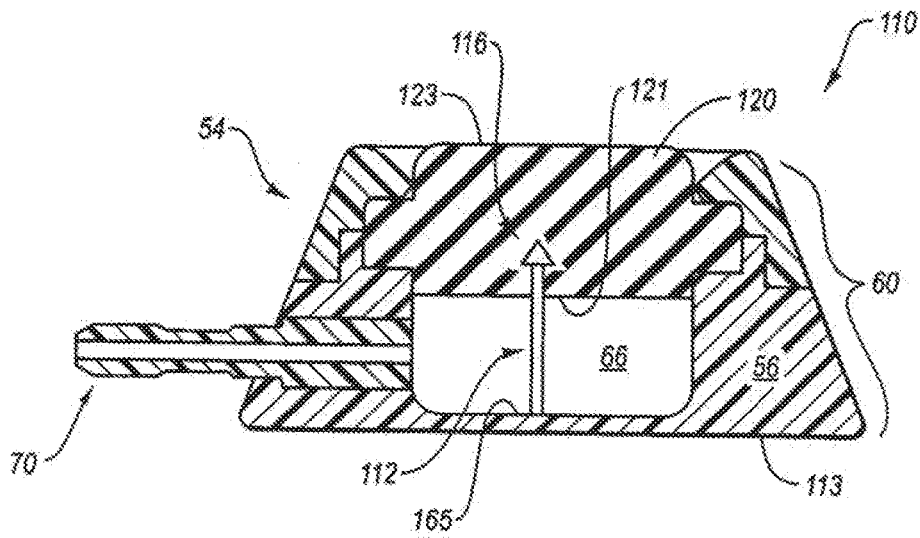

FIG. 13

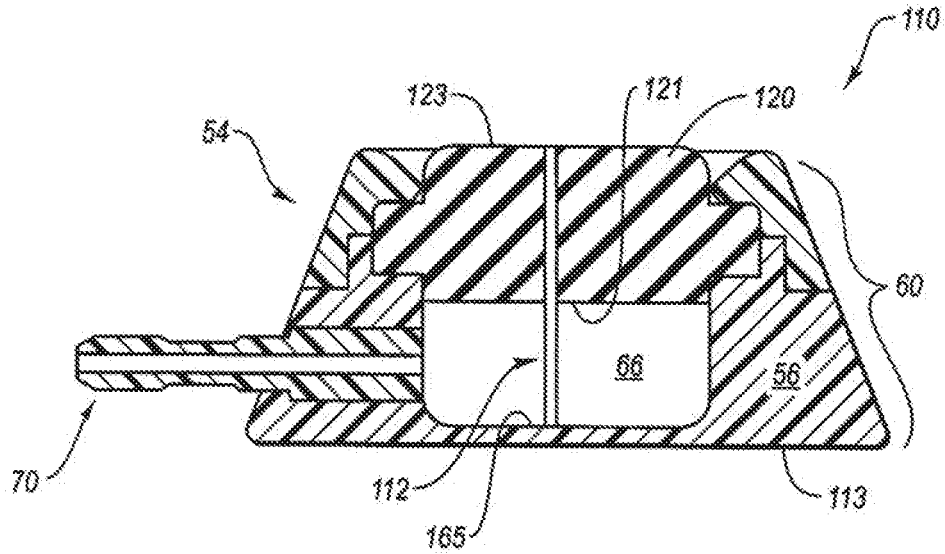

FIG. 14

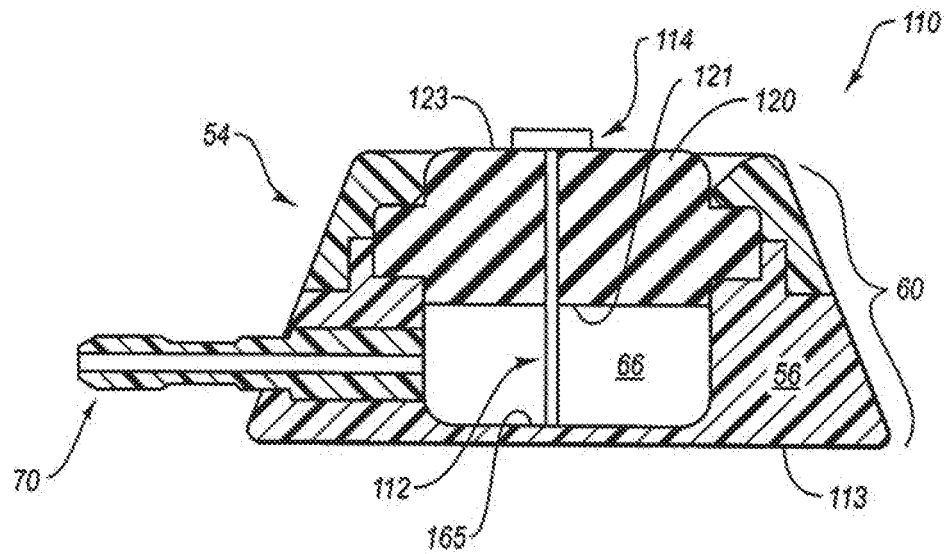

FIG. 15

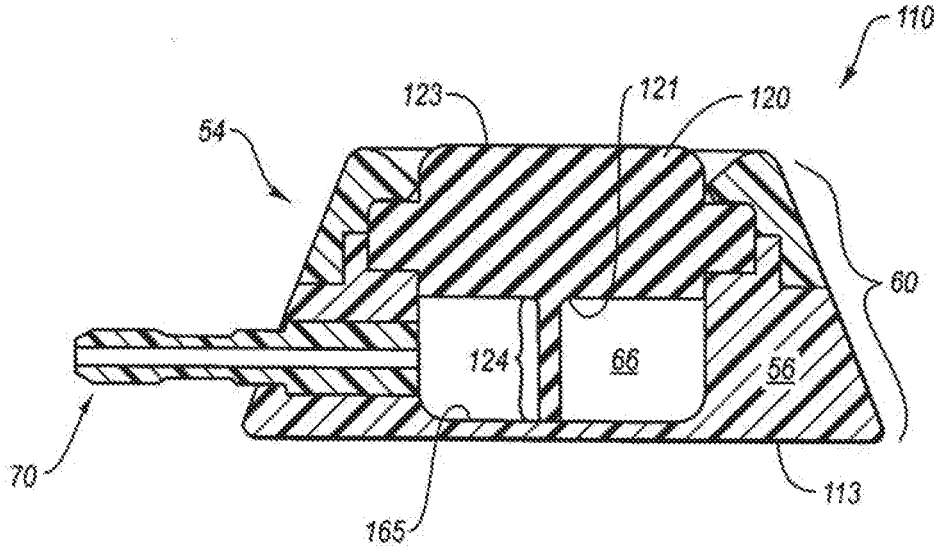

FIG. 16

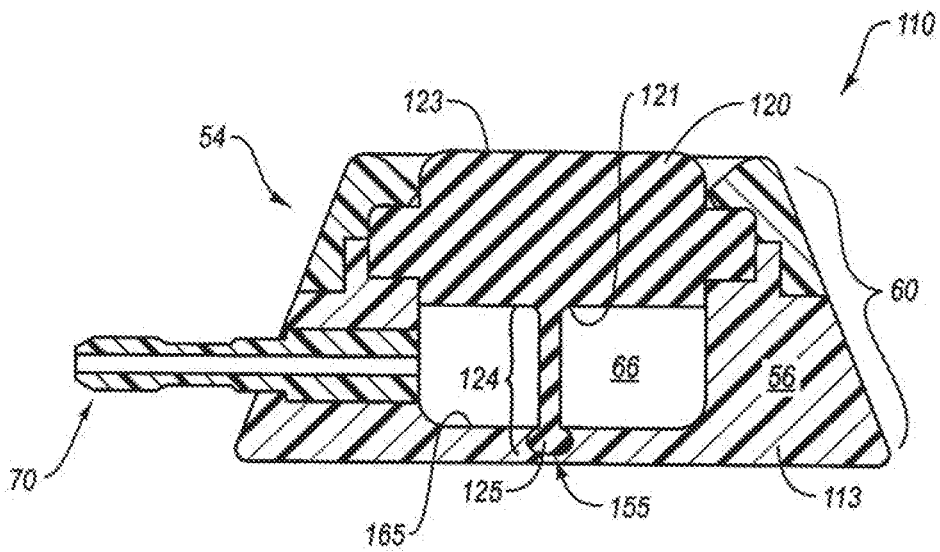

FIG. 17

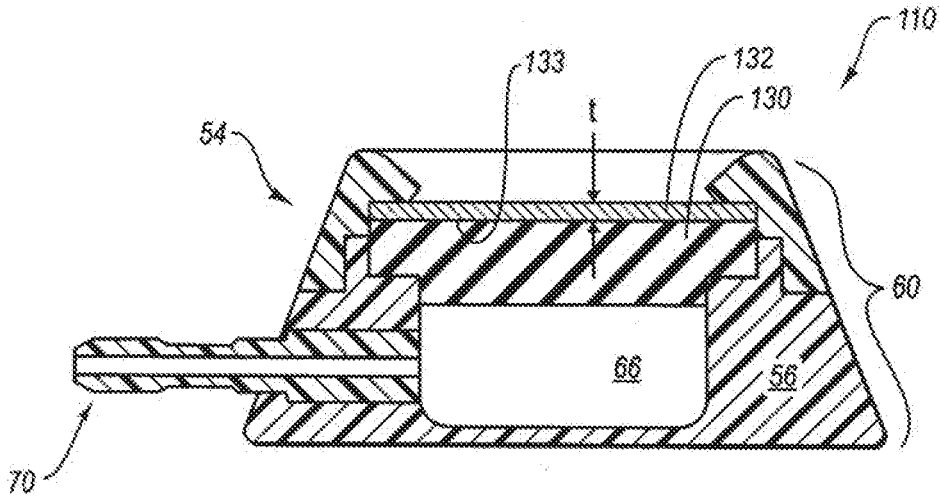

FIG. 18

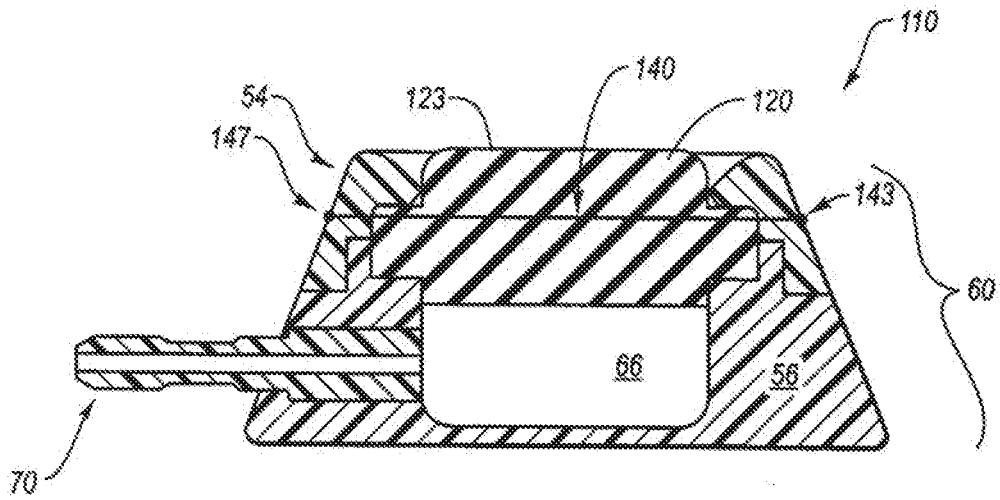

FIG. 19

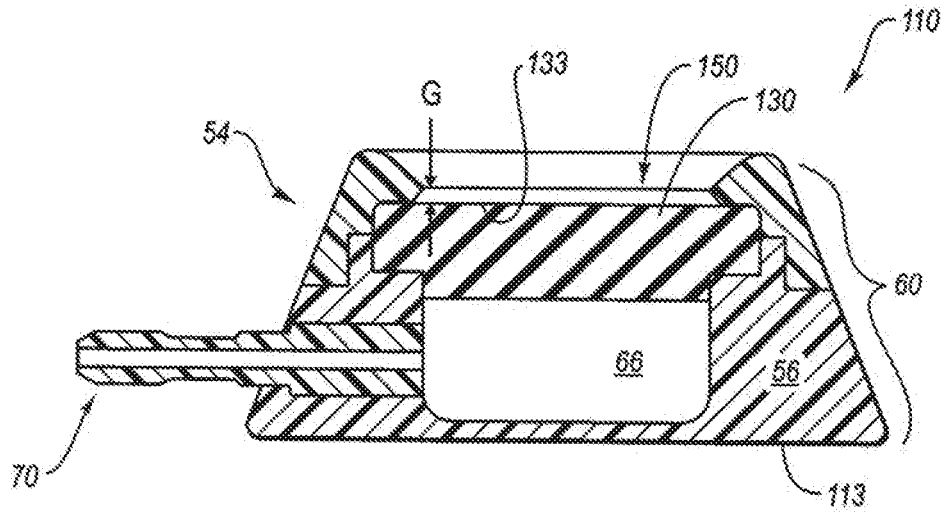

FIG. 20

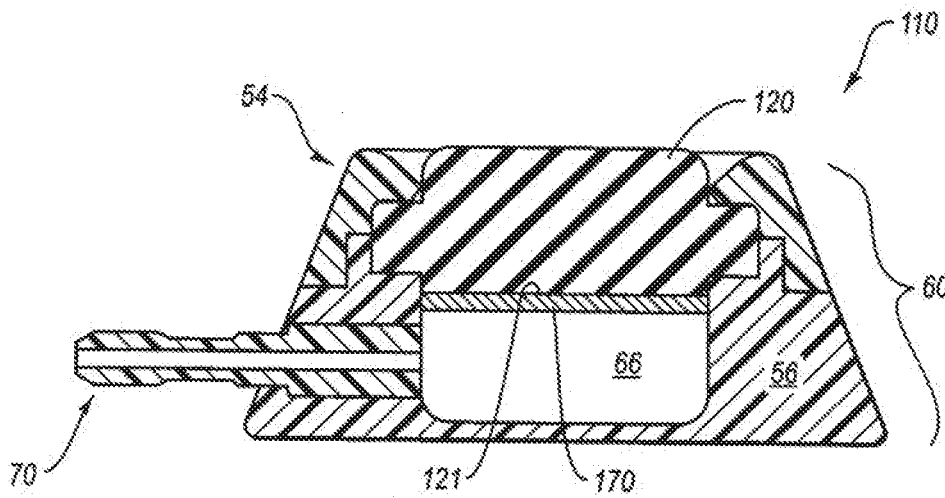

FIG. 21

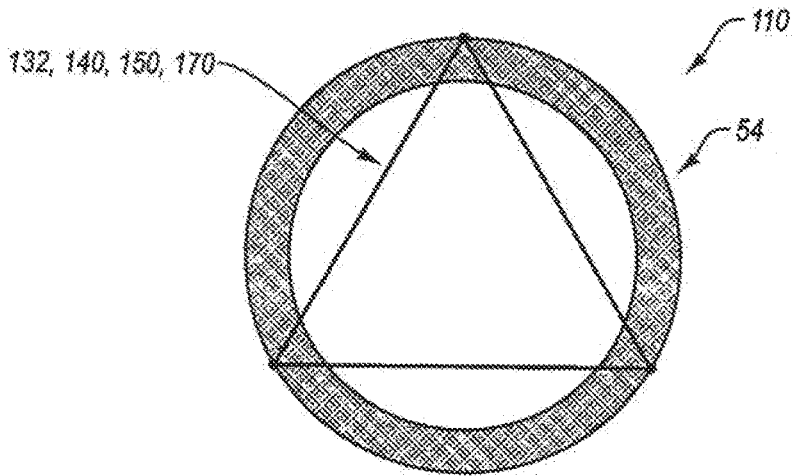

FIG. 22

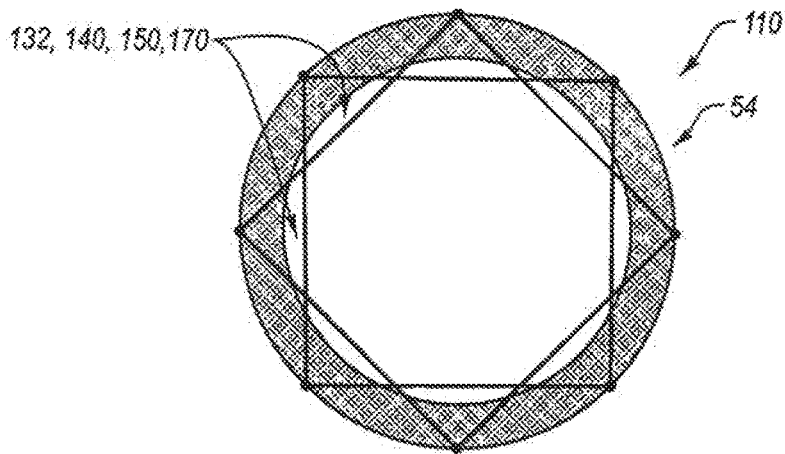

FIG. 23

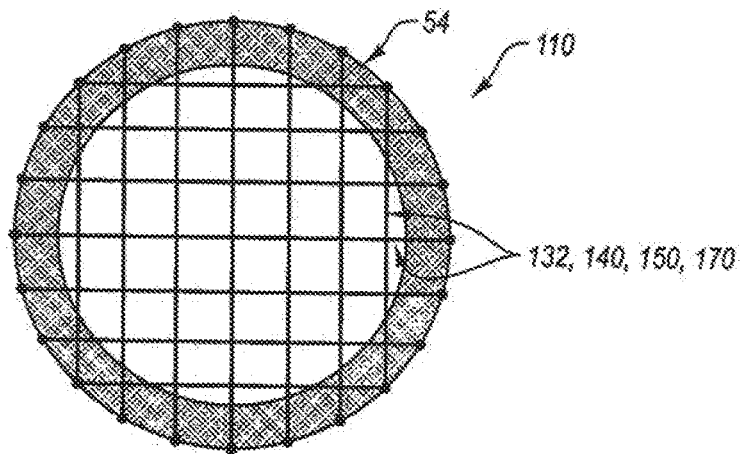

FIG. 24

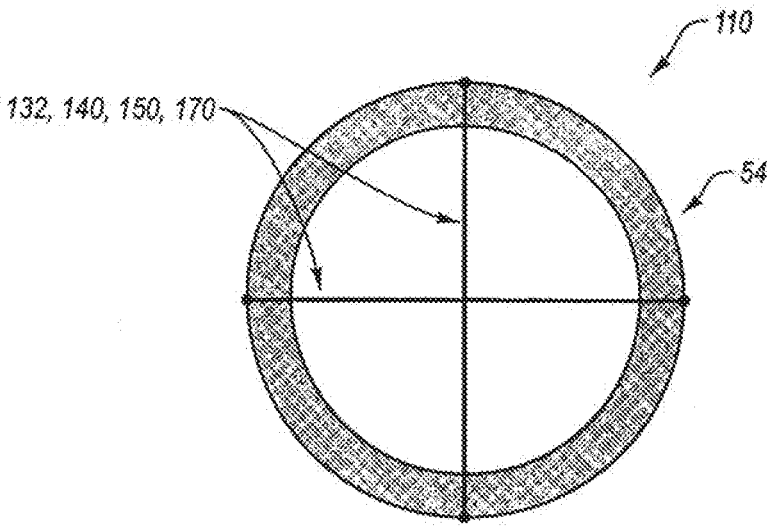

FIG. 25

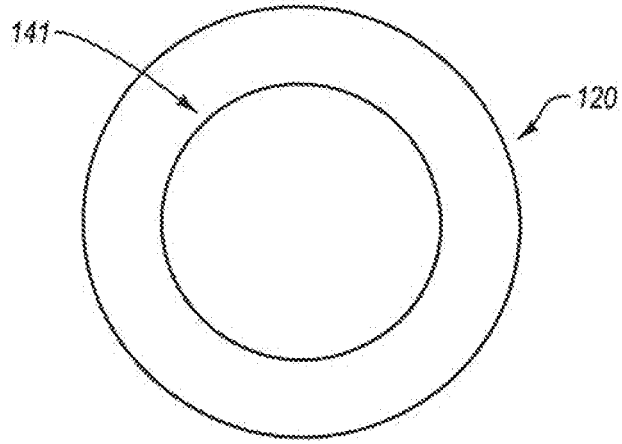

FIG. 26

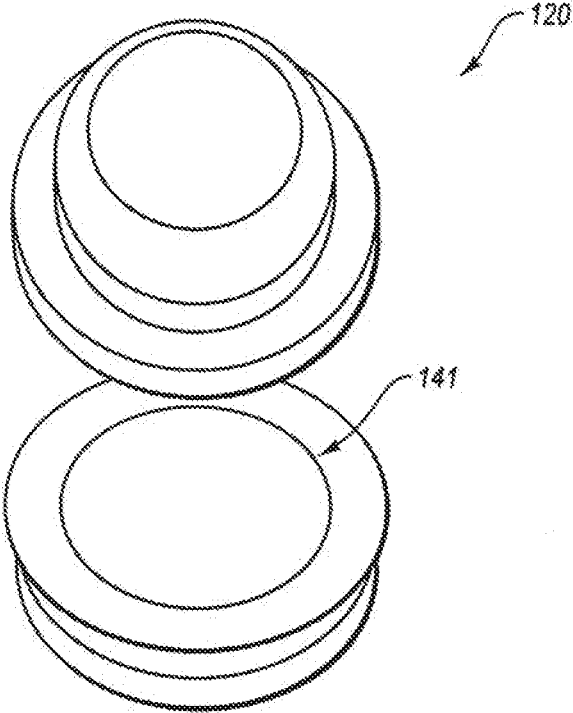

FIG. 27

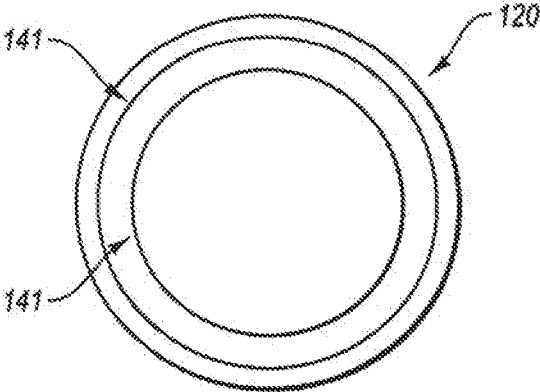

FIG. 28

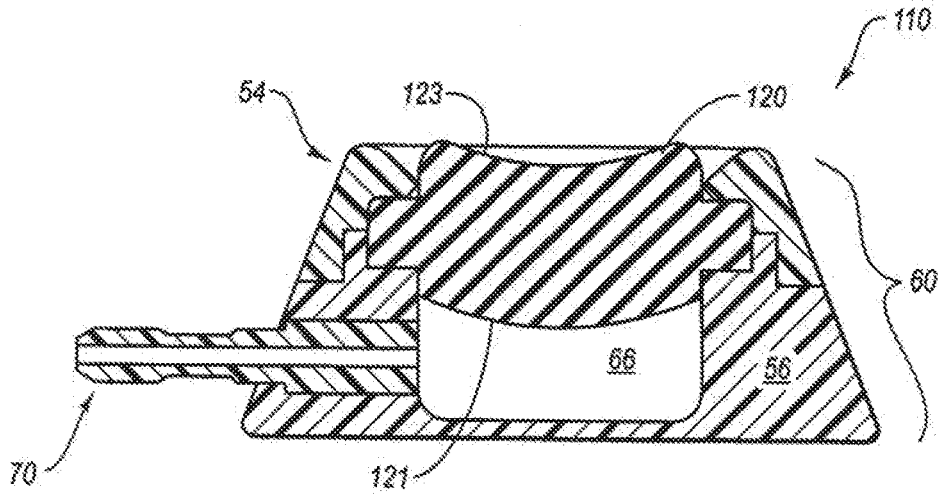

FIG. 29

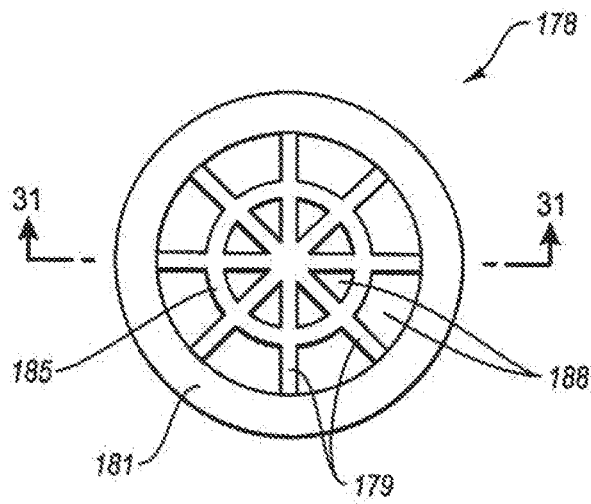

FIG. 30

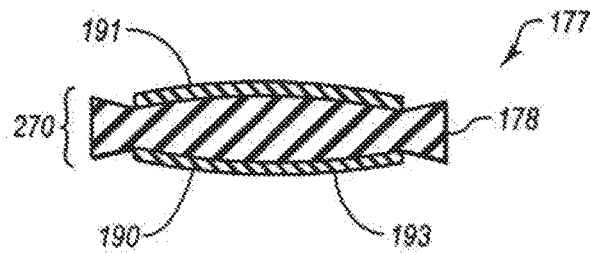

FIG. 31

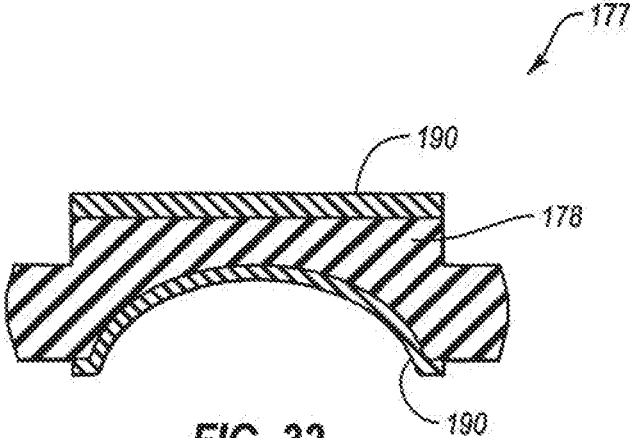

FIG. 32

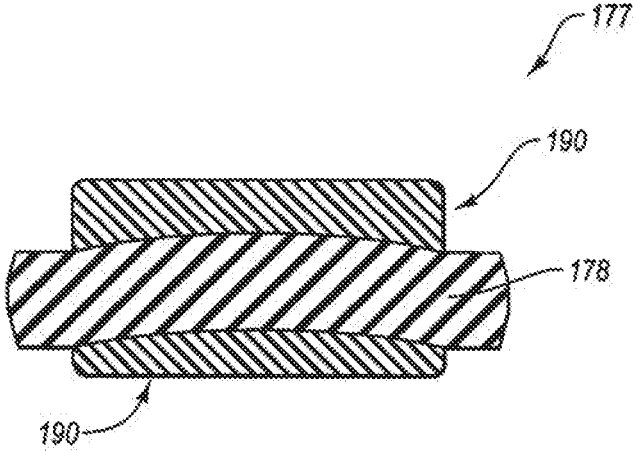

FIG. 33

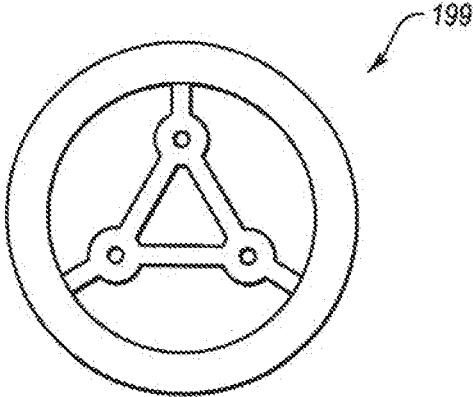

FIG. 34

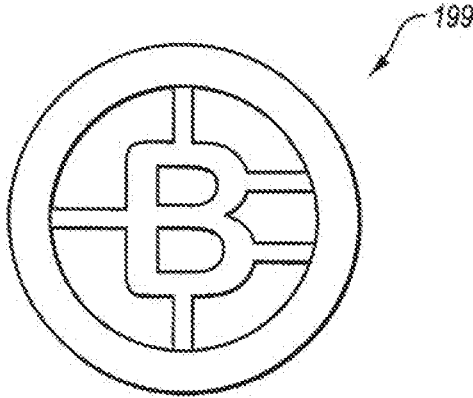

FIG. 35

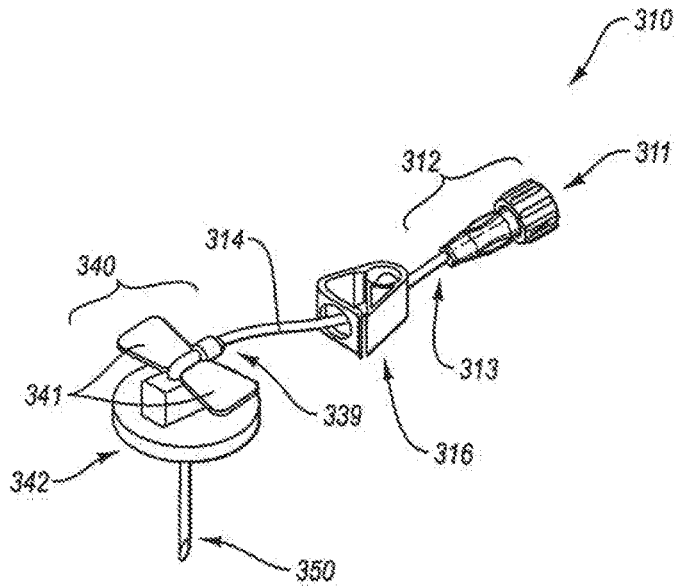

FIG. 36

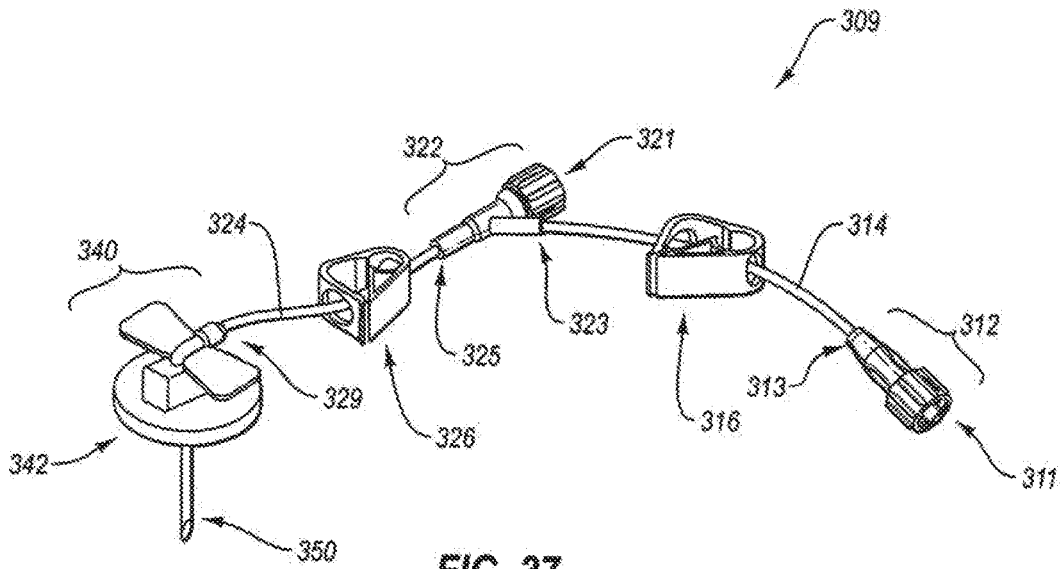

FIG. 37

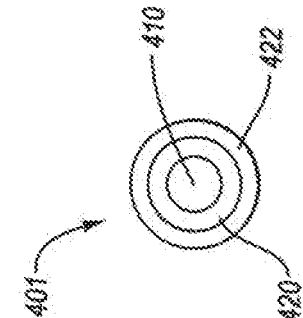

FIG. 39

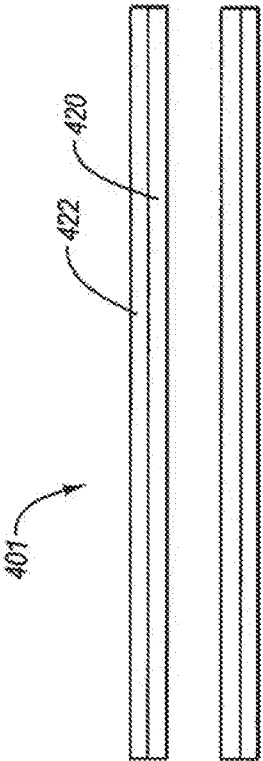

FIG. 38

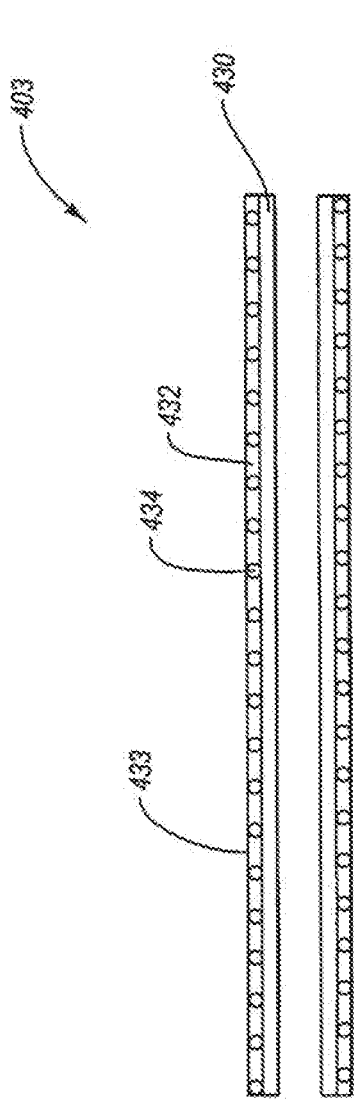

FIG. 40

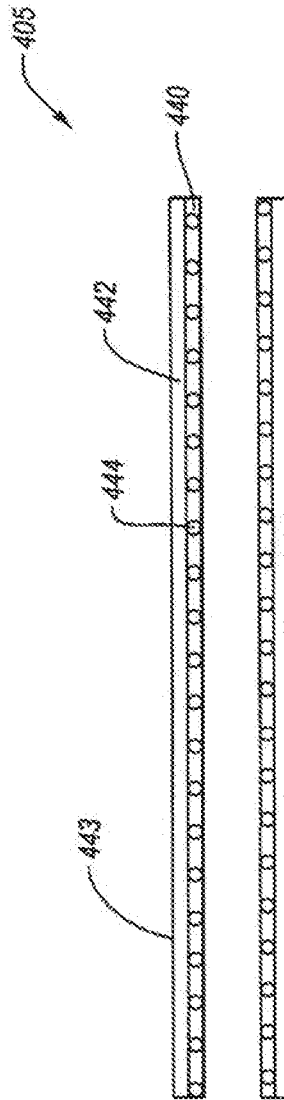

FIG. 41

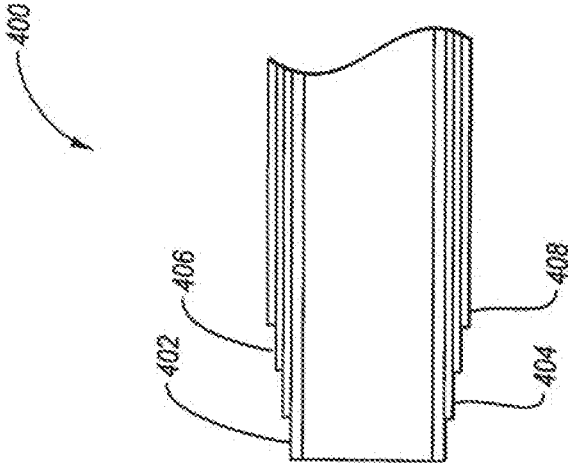

FIG. 43

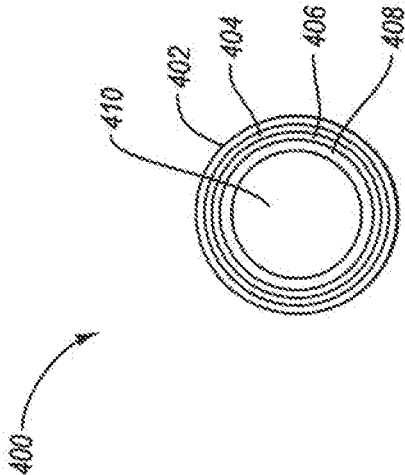

FIG. 42

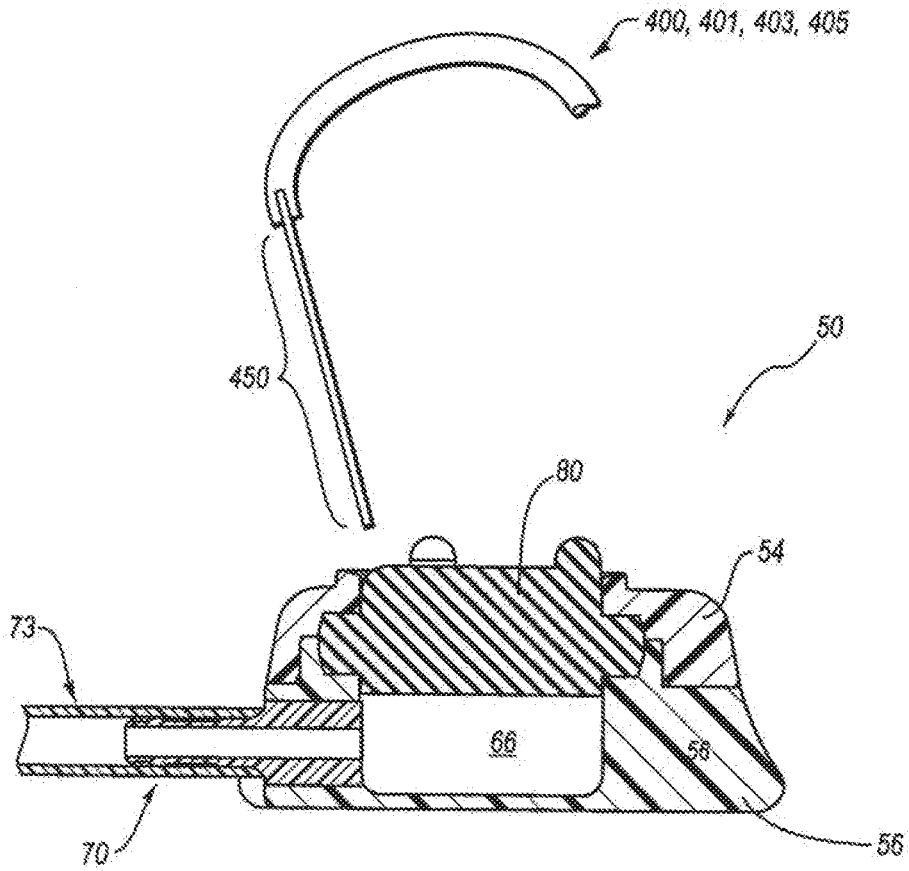

FIG. 44

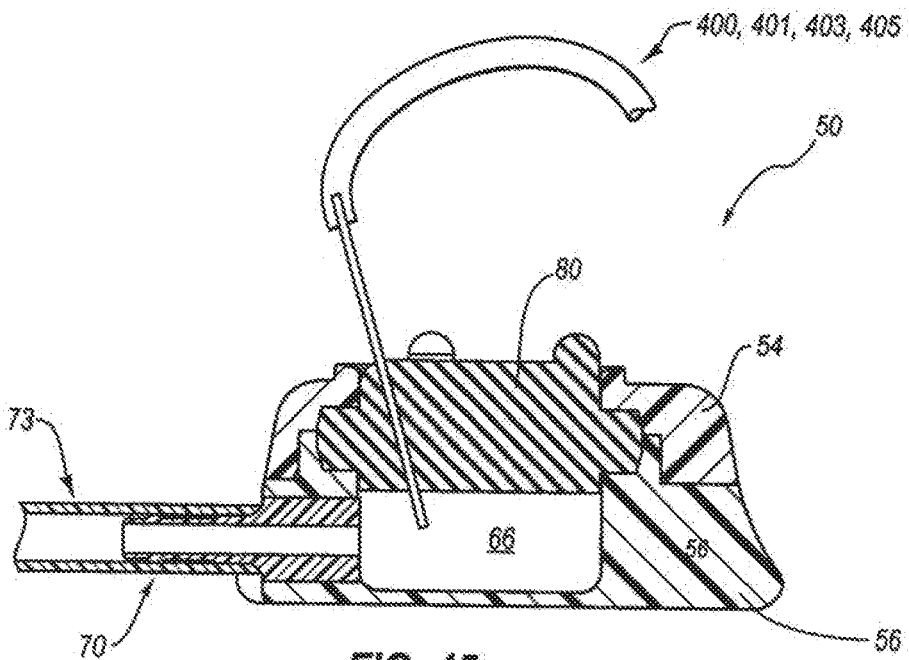

FIG. 45

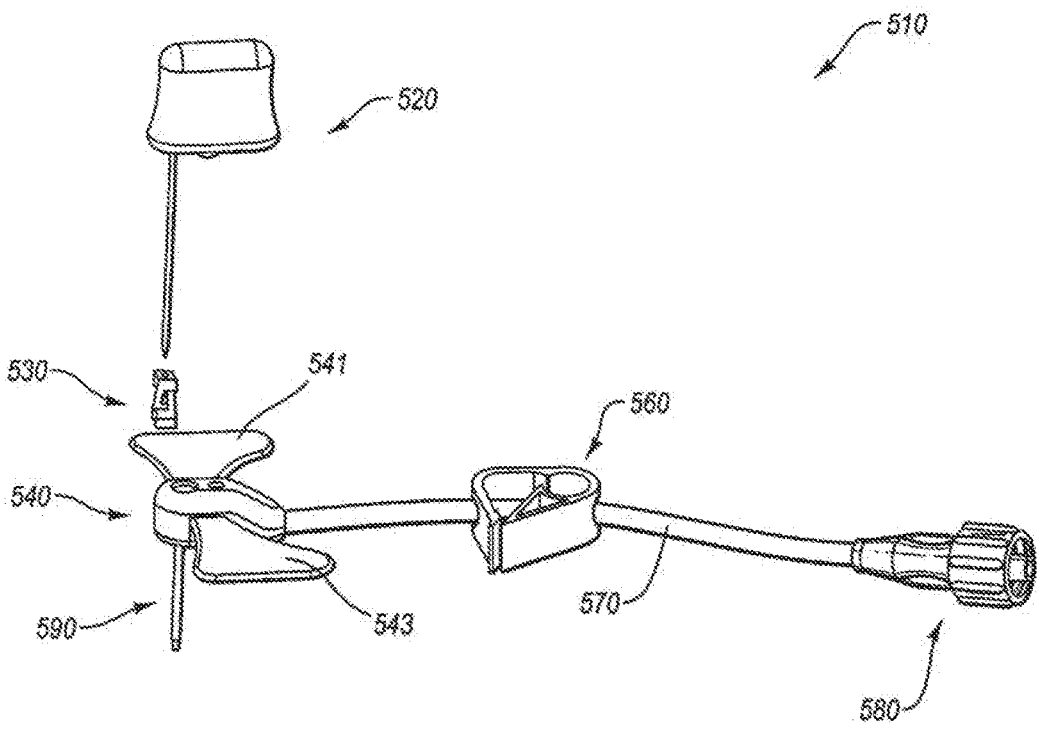

FIG. 46

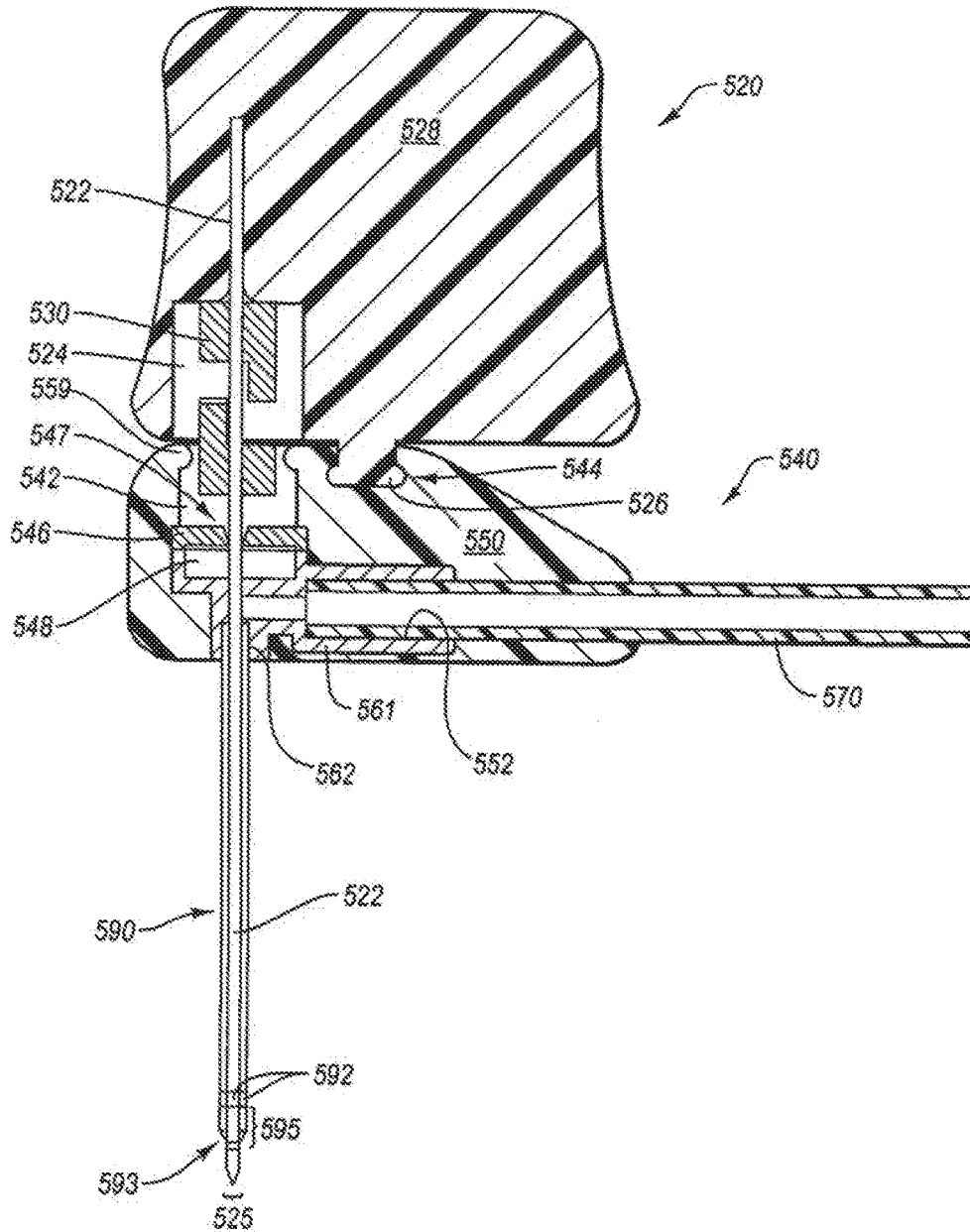

FIG. 47

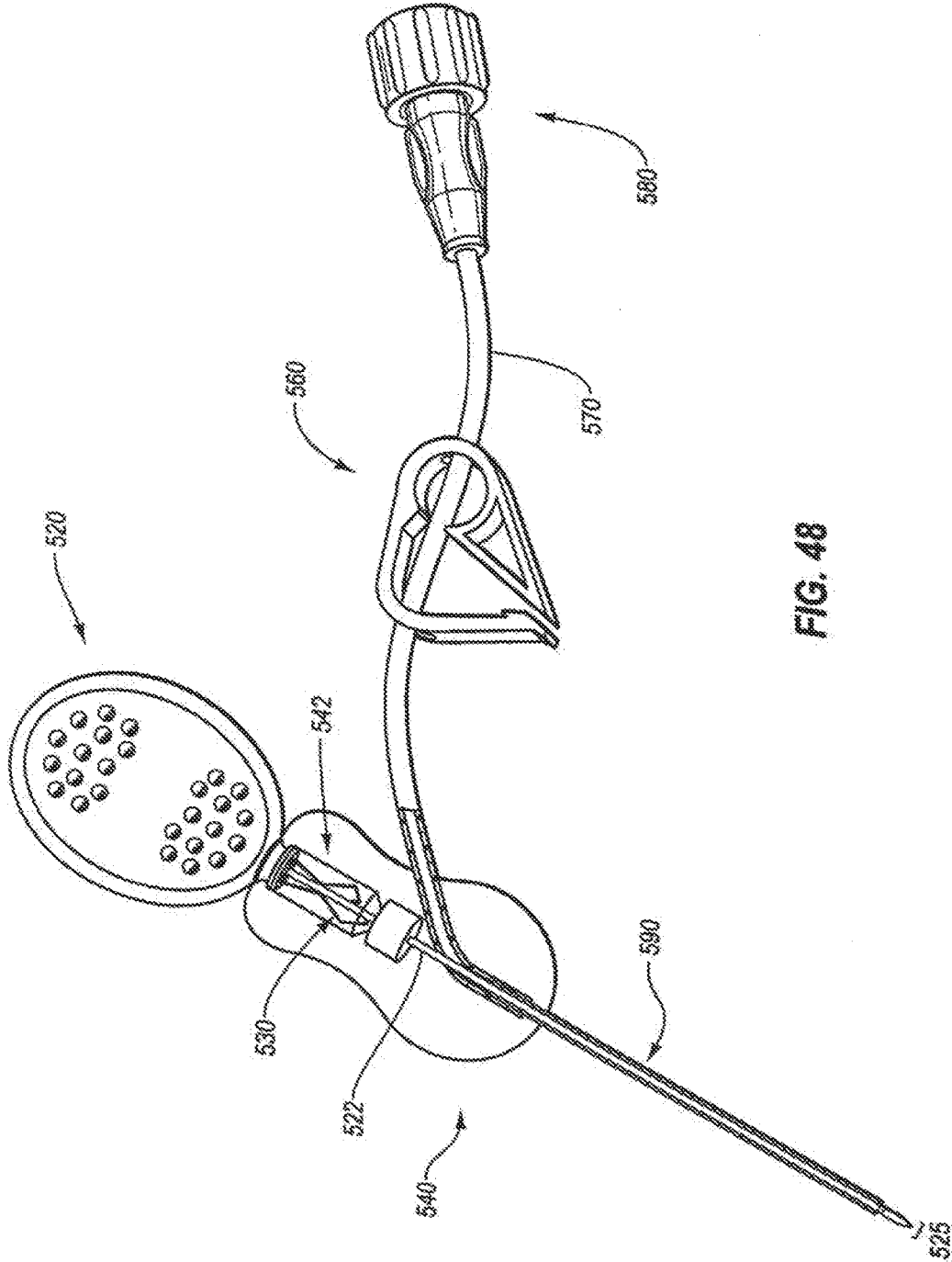

FIG. 48

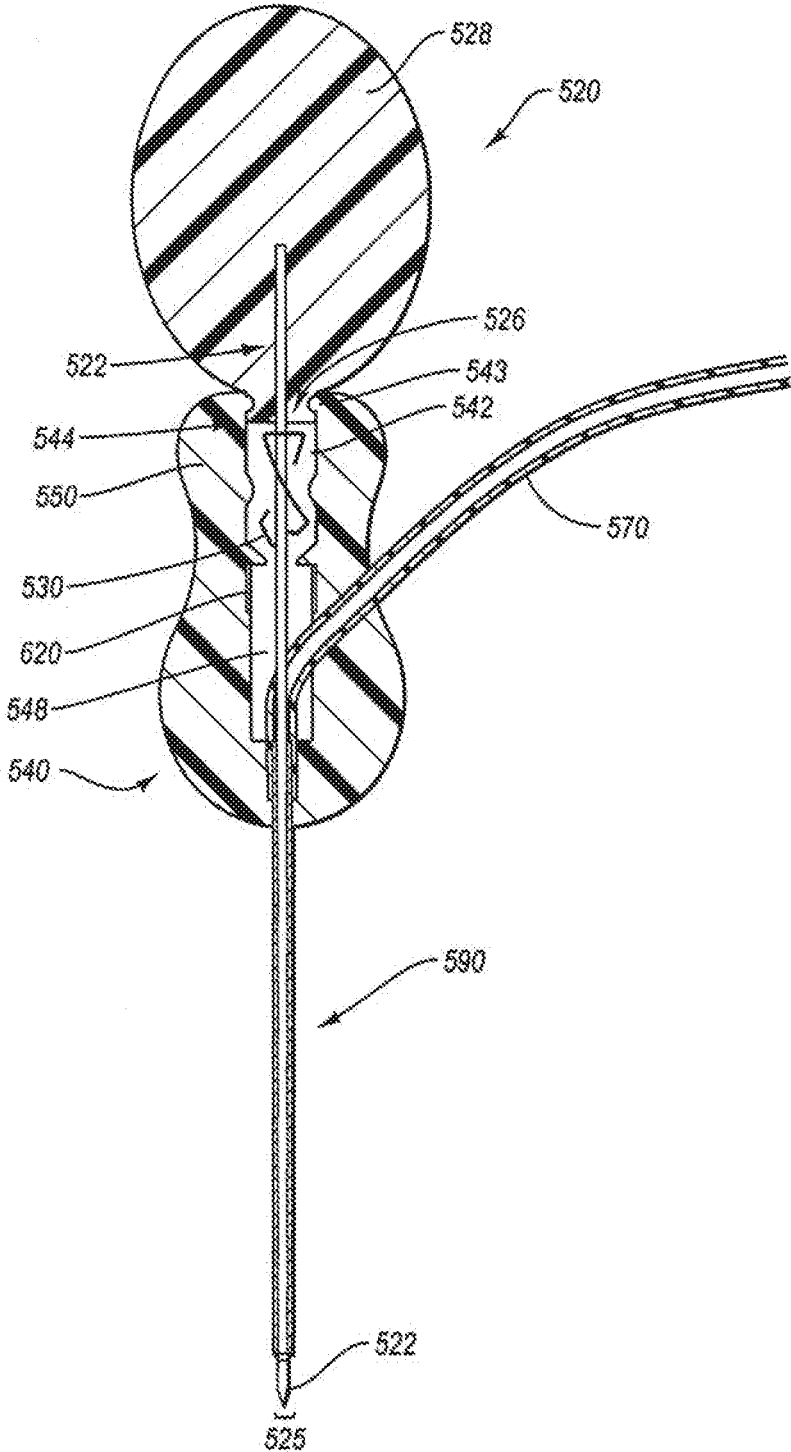

FIG. 49

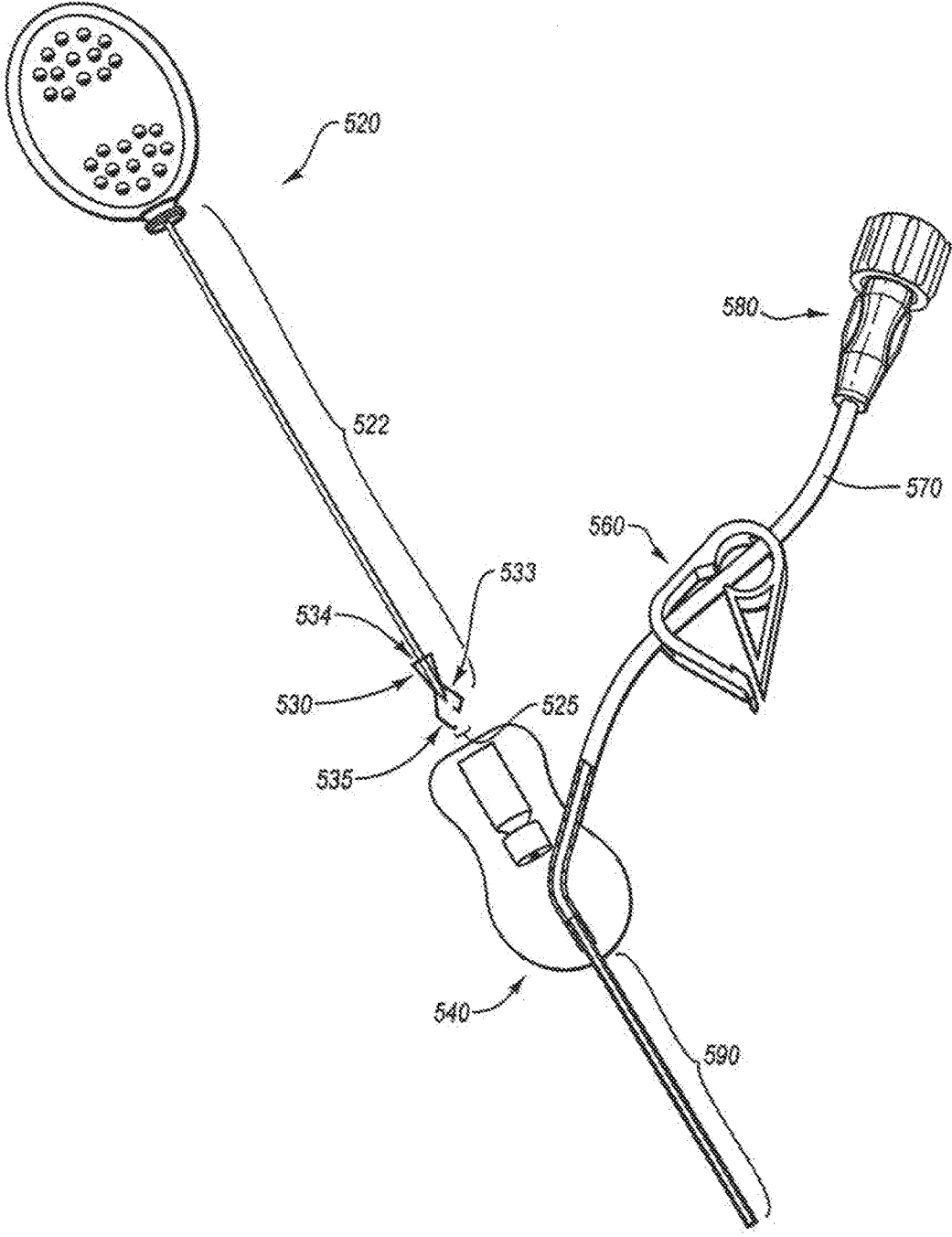

FIG. 50

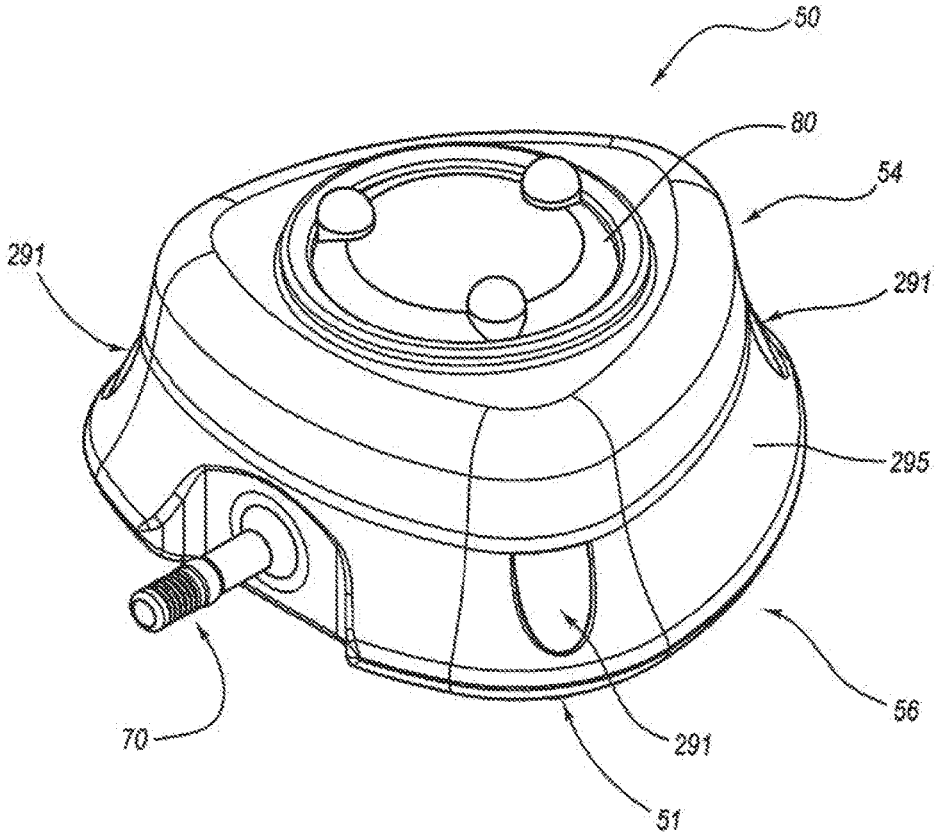

FIG. 51

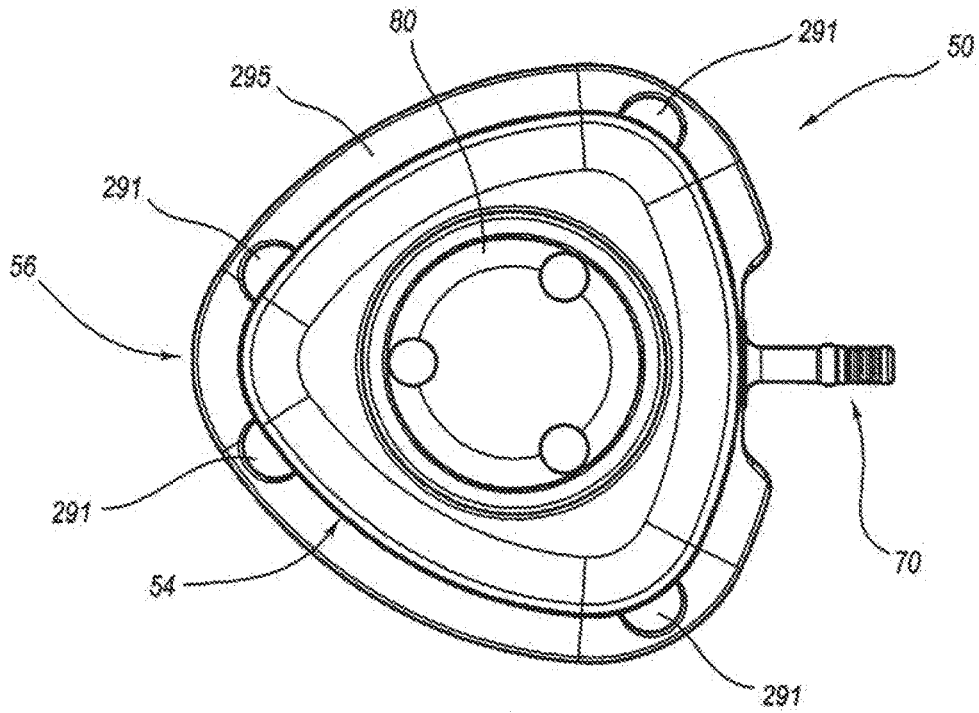

FIG. 52

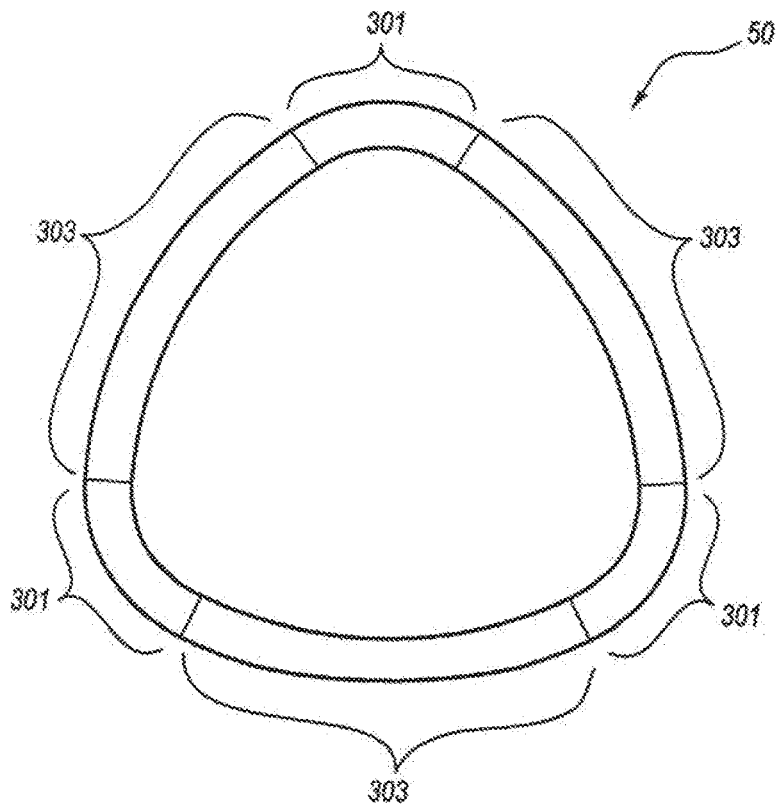

FIG. 53

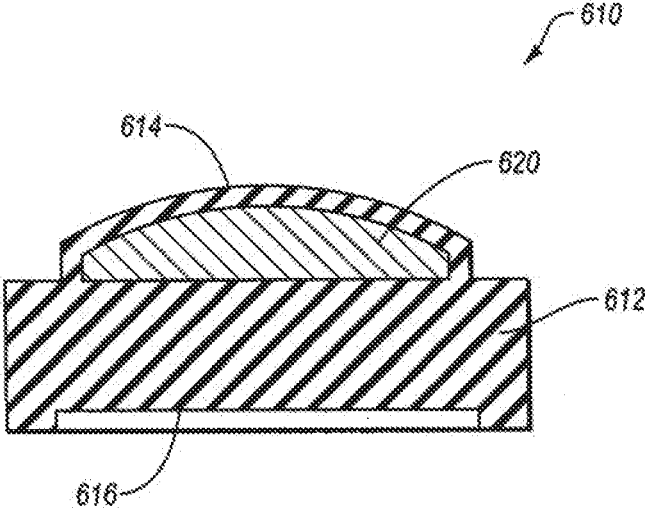

FIG. 54

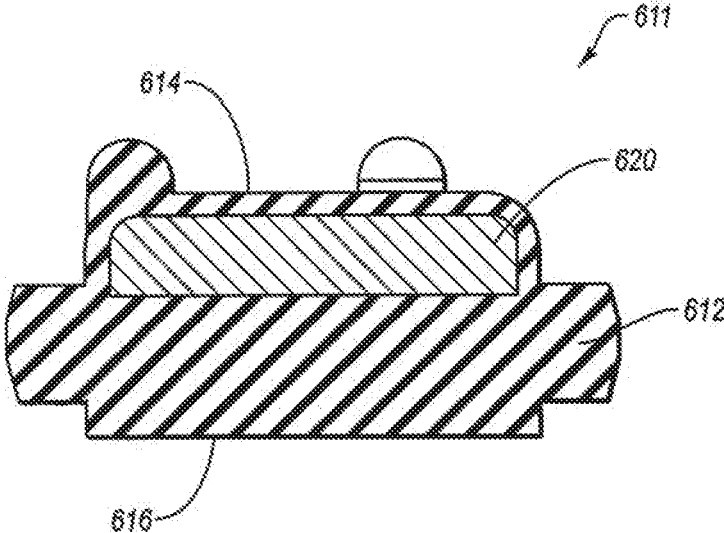

FIG. 55

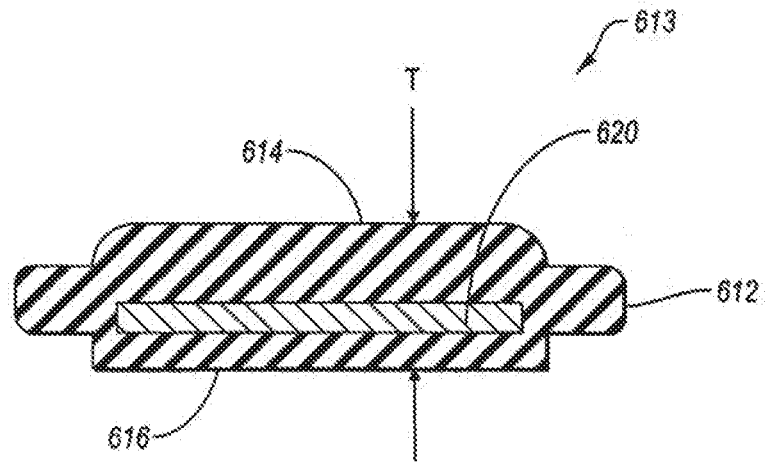

FIG. 56

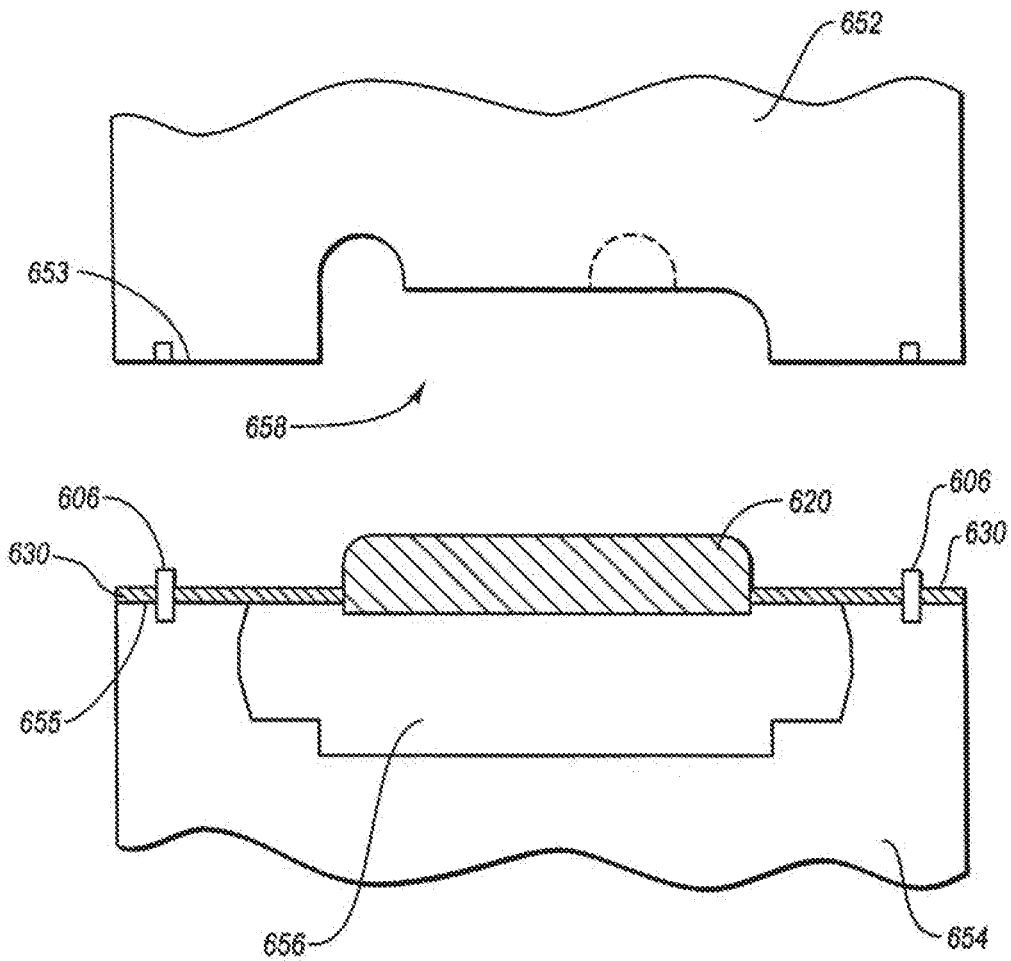

FIG. 57

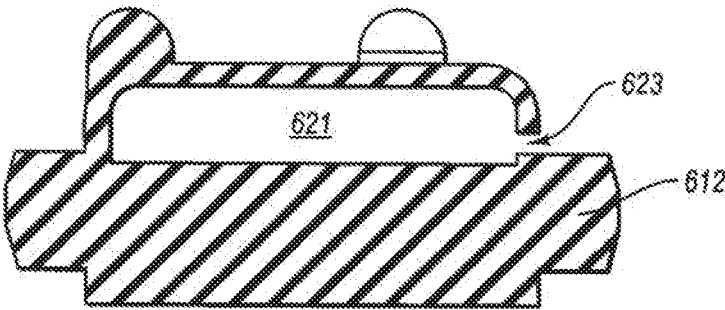

FIG. 58

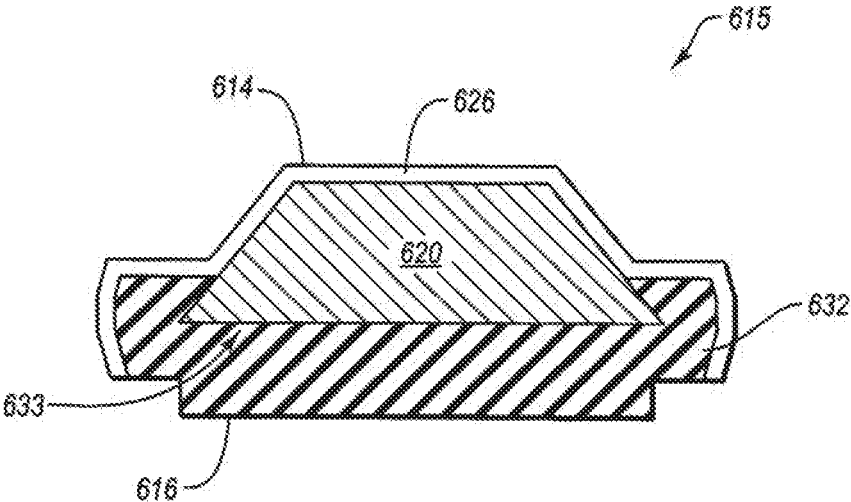

FIG. 59

ASSEMBLIES FOR IDENTIFYING A POWER INJECTABLE ACCESS PORT

CROSS-REFERENCE TO RELATED APPLICATIONS

[0001] This application is a division of U.S. patent application Ser. No. 14/748,917, filed Jun. 24, 2015, now U.S. patent Ser. No. 10/016,585, which is a division of U.S. patent application Ser. No. 14/455,660, filed Aug. 8, 2014, now U.S. Pat. No. 9,937,337, which is a division of U.S. patent application Ser. No. 12/419,854, filed Apr. 7, 2009, now U.S. Pat. No. 8,805,478, which is a division of U.S. patent application Ser. No. 11/380,124, filed Apr. 25, 2006, now U.S. Pat. No. 8,545,460, which claims the benefit of priority to U.S. Provisional Patent Application No. 60/737,466, filed Nov. 15, 2005, and to U.S. Provisional Patent Application No. 60/675,309, filed Apr. 27, 2005, each of which applications is hereby incorporated by reference in its entirety into this application.

BACKGROUND

[0002] A wide variety of medical procedures require infusion of a fluid into a patient. For example, vascular imaging technologies may require use of a contrast media that is injected into the patient. More specifically, computed tomography (CT) is an imaging technology that utilizes a contrast media and may be employed for the noninvasive evaluation and assessment of a vascular system (i.e., CT angiography or CTA). Multidetector computed tomography (MDCT) is one specific type of CT that may be utilized for CTA. For proper imaging of a vascular system via CT, intravenous contrast media injection protocols are coordinated and selected for the anatomic area of interest.

[0003] More particularly, conventionally, a so-called "power injector" system may be employed for injecting contrast media at a high pressure into a peripherally inserted intravenous (IV) line. For example, such power injectors or injection systems may be commercially available from Medrad, Inc., a subsidiary of Schering AG, Germany and may be marketed as STELLANT® injection systems. Because CT procedures are often defined in terms of a desired flow rate of contrast media, such power injection systems are, in general, controllable by selecting a desired flow rate. Accordingly, such power injection systems may develop pressure (within the maximum pressure capability of the power injection system) as is necessary to maintain the selected flow rate. Accordingly, as may be appreciated, obstructions in the IV lines or use of IV lines that are not structured to withstand the pressures of a desired injection rate may cause the power injector to generate a pressure that exceeds a suitable pressure limit for the IV line. After intravenous injection, a bolus of contrast material, may flow within the vascular system of the patient to the right side of the heart, through the lungs, into the left side of the heart, and through the remaining circulatory system. After the bolus of contrast media is injected into the patient, portions of the contrast media may remain in the right side of the heart. Thus, the overall effectiveness of contrast enhancement may depend on a multitude of factors. For example, a patient's characteristics (e.g., body size; circulation, including cardiac output and circulating volume, and renal function), the contrast characteristics (e.g., volume, injection rate, iodine concentration, etc.), and the CT technique (e.g.,

access and route of administration, scan delay, scan speed, and injection pattern) may each influence the overall degree of contrast enhancement.

[0004] By way of background, conventionally, relatively long scan times have been accompanied by relatively long contrast media delivery times. However, because scan times continue to decrease, relatively fast delivery of contrast media may be desired. Explaining further, in coronary CTA, a large enough volume of contrast material must be administered at a sufficiently high rate to reach and maintain a suitable concentration throughout a selected scan time (e.g., a 15 second scan time), and within a selected region of the anatomy (e.g., an axial scan distance of 20 cm, which may include the left ventricle and outflow tract). It also may be desirable that contrast density values are sufficient to facilitate the segmentation techniques used in multidimensional post-processing. A typical contrast media used in coronary CTA may have an iodine density of about 300 milligrams per milliliter to about 350 milligrams per milliliter. Also, since contrast media may be radioactive, reducing the overall quantity of contrast media required to perform an imaging process may be advantageous.

[0005] The pressure required for contrast injection depends on many factors, including flow rate, contrast viscosity, configuration of infusion tubing, such as tube diameter and length, and any obstruction or restriction to flow (e.g., kinks, curves, fittings, compression). As mentioned above, to maintain the flow rate required for a CT or Mill study, a power injector may generate high pressures. Ruptures can occur when the injection pressure exceeds the tolerance of the vascular access device(s). Other problems may occur due to timing errors between the scan and the contrast. In order to maximize the rapid scanning capacity of the newer vascular imaging devices, the starting of the scanning process can be delayed a predetermined amount of time after injection of the contrast media has begun. If the scan starts too early, just as the contrast is arriving at the heart, arteries can appear smaller than they really are when the image is post-processed. On the other hand, if scanning is delayed too long, image artifacts can arise from diluted contrast in the cardiac veins. The window of opportunity for optimal scans may be very small, because contrast media circulates quickly through cardiac arteries and into cardiac veins.

[0006] Some diagnostic or medical procedures may advantageously employ a subcutaneous vascular access port for introducing a fluid into the vasculature of a patient. Access portals, or ports, provide a convenient method to repeatedly deliver medicants to remote areas of the body without utilizing surgical procedures. The port is implantable within the body, and permits the infusion of medications, parenteral solutions, blood products, contrast media, or other fluids. Additionally, the port may be used to aspirate blood from the patient. Such access ports typically include a cannula-impenetrable housing which encloses one or more fluid cavities or reservoirs and defines for each such fluid cavity an access aperture communicating through the housing. A cannula-penetrable septum is positioned adjacent to and seals each access aperture. An outlet stem communicates with one or more of the fluid cavities for dispensing medication therefrom to a predetermined location in the body of the patient through an implanted catheter attached to the access port. Once the access port and the catheter have been implanted beneath the skin of a patient, quantities of fluid,

such as medication, blood, etc., may be dispensed through one such fluid cavity by, for example, a cannula (e.g., a needle), passed through the skin of the patient and penetrating the septum into one of the respective fluid cavities. This medication is directed through the distal end of the catheter to an entry point into the venous system of the body of the patient. Further, blood may be aspirated through the subcutaneous access port. Thus, use of an access port may allow for vascular access without needle sticks into the vasculature of a patient.

[0007] However, conventional access ports and attendant infusion systems have not been suitable for performing power injection.

[0008] Particularly, the use of power injection systems in combination with conventional vascular access ports has achieved less than ideal results. Thus, it may be appreciated that vascular access ports for infusion systems and infusion-related apparatuses structured for performing power injection may be advantageous.

SUMMARY

[0009] One aspect of the instant disclosure relates to a method of flowing fluid through an access port. More particularly, a vascular access port may be provided and a fluid may be caused to flow through the access port at a rate of at least about 1 milliliter per second.

[0010] A further aspect of the instant disclosure relates to a method of flowing fluid through an infusion set. For example, an infusion set may be provided and a fluid may be flowed through the infusion set at a rate of at least about 1 milliliter per second.

[0011] Another aspect of the instant disclosure relates to an access port for providing subcutaneous access to a patient. Specifically, an access port may comprise a housing defining an aperture for capturing a septum, wherein the housing and septum define a reservoir. In addition, the septum may include a tenon region wherein the housing of the access port defines a complimentary mortise region structured for accepting at least a portion of the tenon region of the septum. Optionally, the housing may include a ring structure proximate to at least a portion of a side periphery of the septum.

[0012] An additional aspect of the instant disclosure relates to an access port for providing subcutaneous access to a patient. In one embodiment, an access port may comprise a housing defining an aperture for capturing a septum, the housing and septum defining a reservoir. In addition, the housing and septum may be structured for accommodating a flow rate through the reservoir of at least about 1 milliliter per second. In another embodiment, an access port may include a housing and septum, as described above, wherein the housing and the septum are structured for accommodating a pressure developed within the reservoir of at least about 35 psi.

[0013] Yet another aspect of the instant disclosure relates to an infusion set for use in subcutaneously accessing a patient. For example, in one embodiment, an infusion set may comprise a tubing section defining a lumen and a cannula in fluid communication with the lumen of the tubing section. Also, the cannula may be configured for insertion through a septum of an access port, and the tubing section and the cannula may be structured for allowing a fluid to flow at a rate of at least about 1 milliliter per second. Optionally the cannula may be configured for puncturing a

septum of an access port and the tubing section and the cannula may be structured for accommodating a pressure of at least about 400 psi. For example, the tubing section and the cannula may be structured for accommodating a pressure of about 600 psi.

[0014] A further aspect of the instant disclosure relates to infusion tubing for use in accessing a vascular system of a patient. In one embodiment, infusion tubing may comprise a plurality of layers, wherein the tubing is structured for accommodating a fluid flow rate of at least about 1 milliliter per second. In another embodiment, infusion tubing may comprise a plurality of layers, wherein at least one layer of the plurality of layers extends beyond at least another of the plurality of layers and is structured for forming a cannula for puncturing a septum of an access port. In yet an additional embodiment, an infusion set for use in subcutaneously accessing a patient may comprise a tubing section defining a lumen and a cannula in fluid communication with the lumen of the tubing section, wherein the cannula is configured for insertion through a septum of an access port. Additionally, the tubing section and cannula may be structured for accommodating a pressure of at least about 400 psi.

[0015] Another aspect of the instant disclosure relates to a method of identifying an access port as being suitable for power injection. More specifically, an access port including a septum may be provided. Further, the access port may be identified as being suitable for power injection.

[0016] Yet a further aspect of the instant disclosure relates to an access port for providing subcutaneous access to a patient. Particularly, an access port may comprise a housing configured for capturing a septum, the septum configured for inserting a cannula therethrough and into a reservoir defined within the housing and at least one structural element configured for resisting deformation of the septum in response to a pressure developed within the reservoir.

[0017] In an additional aspect of the instant disclosure, a method of operation of an access port may comprise providing a housing configured for capturing a septum, the septum configured for inserting a cannula (which can include a needle, a Huber needle, a trocar with an associated cannula, or any combination thereof) therethrough and into a reservoir defined within the housing, and developing a pressure within the reservoir of the housing. Further, such a method may comprise limiting deformation of the septum in response to the pressure developed within the reservoir.

[0018] In addition, one aspect of the instant disclosure relates to a septum comprising a gel or a viscous liquid. For example, in one embodiment, a septum for assembly with a housing to form an access port for providing subcutaneous access to a patient may comprise a body including an upper surface and a lower surface and at least one gel region positioned generally between the upper surface and the lower surface. Another embodiment may comprise a septum for assembly with a housing to form an access port for providing subcutaneous access to a patient may comprise a body, a layer formed over at least a portion of the body, and a gel region positioned at least partially between the layer and the body.

[0019] The above-described infusion apparatuses and related methods may be beneficially employed for effecting or facilitating power injection processes. For instance, such methods and apparatuses may be employed for infusing a fluid (e.g., a contrast media) at a rate of between about 1 milliliter per second and about 5 milliliters per second.

[0020] Features from any of the above mentioned embodiments may be used in combination with one another in accordance with the instant disclosure. In addition, other features and advantages of the instant disclosure will become apparent to those of ordinary skill in the art through consideration of the ensuing description, the accompanying drawings, and the appended claims.

BRIEF DESCRIPTION OF THE DRAWINGS

[0021] Advantages of the instant disclosure will become apparent upon review of the following detailed description and drawings, which illustrate representations (not necessarily drawn to scale) of various aspects of the instant disclosure, wherein:

[0022] FIG. 1 shows an exploded, perspective view of an access port according to the instant disclosure;

[0023] FIG. 2 shows a schematic, side cross-sectional view of the access port shown in FIG. 1;

[0024] FIG. 3 shows a schematic, top elevation view of a cap including a ring feature as shown in FIGS. 1 and 2;

[0025] FIG. 4 shows a schematic, top elevation view of another embodiment of a cap including a ring feature;

[0026] FIG. 5 shows a schematic, top elevation view of a further embodiment of a cap including a ring feature;

[0027] FIG. 6 shows a schematic, side cross-sectional view of an implanted access port with a cannula extending through the septum of the access port;

[0028] FIG. 7 shows a graph depicting pressures at selected regions within an infusion system for a given flow rate;

[0029] FIG. 8 shows a schematic, side cross-sectional view of an access port including a septum with a tenon region and a housing with a mortise region;

[0030] FIG. 9 shows a schematic, side cross-sectional view of another embodiment of an access port including a septum with a tenon region and a housing defining a mortise region;

[0031] FIG. 10 shows a schematic, side cross-sectional view of a further embodiment of an access port including a tenon region and a housing defining a mortise region;

[0032] FIG. 11 shows a schematic, side cross-sectional view of an access port, wherein at least a portion of a side periphery of the septum is affixed to the housing;

[0033] FIG. 12 shows a schematic, side cross-sectional view of an access port including a structural element extending between the septum and the housing;

[0034] FIG. 13 shows a schematic, side cross-sectional view of an access port including a structural element with a barbed end positioned within the septum;

[0035] FIG. 14 shows a schematic, side cross-sectional view of an access port including a structural element extending between an upper surface of the septum and the housing;

[0036] FIG. 15 shows a schematic, side cross-sectional view of an access port as shown in FIG. 14 and also including a support element positioned adjacent to an upper surface of the septum;

[0037] FIG. 16 shows a schematic, side cross-sectional view of an access port including a septum with an extension leg that extends to the housing;

[0038] FIG. 17 shows a schematic, side cross-sectional view of an access port including a septum with an extension leg comprising an enlarged end that couples to a recessed form in the housing;

[0039] FIG. 18 shows a schematic, side cross-sectional view of an access port including a septum in a structural element positioned adjacent to an upper surface of the septum;

[0040] FIG. 19 shows a schematic, side cross-sectional view of an access port including a septum and a structural element extending laterally through the septum;

[0041] FIG. 20 shows a schematic, side cross-sectional view of an access port including a septum and a structural element positioned proximate to an upper surface of the septum;

[0042] FIG. 21 shows a schematic, side cross-sectional view of an access port including a septum and a structural element positioned proximate to a lower surface of the septum;

[0043] FIG. 22 shows a partial, top elevation view of an access port, as shown in FIGS. 18-21, wherein structural elements are arranged in a generally triangular pattern;

[0044] FIG. 23 shows a partial, top elevation view of an access port, as shown in FIGS. 18-21, wherein structural elements are arranged in two generally rectangular patterns;

[0045] FIG. 24 shows a partial, top elevation view of an access port, as shown in FIGS. 18-21, wherein structural elements are arranged in a first plurality of substantially parallel lines and a second plurality of substantially parallel lines;

[0046] FIG. 25 shows a partial, top elevation view of an access port as shown in FIGS. 18-21, wherein structural elements are arranged as two intersecting substantially straight members;

[0047] FIG. 26 shows a partial, top elevation view of a septum including a structural element positioned within the septum;

[0048] FIG. 27 shows a perspective view of a sectioned septum, as shown in FIG. 26;

[0049] FIG. 28 shows a partial, top elevation view of a septum including a plurality of structural elements;

[0050] FIG. 29 shows a schematic, side cross-sectional view of an access port including a septum exhibiting curvature;

[0051] FIG. 30 shows a top elevation view of one embodiment of a septum frame;

[0052] FIG. 31 shows a schematic, side cross-sectional view of one embodiment of a septum including the frame shown in FIG. 30 and another material at least partially surrounding the frame;

[0053] FIG. 32 shows a schematic, side cross-sectional view of another embodiment of a septum including a frame that is at least partially surrounded by another material;

[0054] FIG. 33 shows a schematic, side cross-sectional view of yet an additional embodiment of a septum including a frame that is at least partially surrounded by another material;

[0055] FIGS. 34 and 35 show a respective schematic view of different patterns that may be generated by radiopaque material comprising a septum;

[0056] FIG. 36 shows a perspective view of one embodiment of an infusion set according to the instant disclosure;

[0057] FIG. 37 shows a perspective view of another embodiment of an infusion set according to the instant disclosure;

[0058] FIGS. 38 and 39 show a side cross-sectional view and an end cross-sectional view of one embodiment of tubing including an inner layer and an outer layer;

[0059] FIG. 40 shows a schematic, side cross-sectional view of tubing including an inner layer, an outer layer, and at least one reinforcing element;

[0060] FIG. 41 shows a schematic, side cross-sectional view of another embodiment of tubing including an inner layer, an outer layer, and at least one reinforcing element;

[0061] FIGS. 42 and 43 show an end cross-sectional view and a schematic, side cross-sectional view, respectively, of tubing including four layers;

[0062] FIGS. 44 and 45 show schematic, side cross-sectional views of a tubing section including a plurality of layers, wherein at least one layer of the plurality of layers extends from a distal end of the tubing to form a slender hollow region for insertion through a septum of an access port;

[0063] FIG. 46 shows a perspective view of one embodiment of an infusion system configured for inserting a flexible catheter through a septum of an access port;

[0064] FIG. 47 shows a schematic, partial, side cross-sectional view of the infusion system shown in FIG. 46;

[0065] FIG. 48 shows a perspective view of another embodiment of an infusion system configured for inserting a flexible catheter through a septum of an access port;

[0066] FIG. 49 shows a schematic, partial, side cross-sectional view of the infusion system shown in FIG. 48;

[0067] FIG. 50 shows a perspective view of the infusion system shown in FIG. 48, wherein the insertion assembly is removed from the hub;

[0068] FIG. 51 shows a perspective view of one embodiment of an access port according to the instant disclosure;

[0069] FIG. 52 shows a top elevation view of the access port shown in FIG. 51;

[0070] FIG. 53 shows a simplified representation of a transverse cross-section of the access port shown in FIGS. 51 and 52;

[0071] FIG. 54 shows a schematic, side cross-sectional view of one embodiment of a septum including at least one gel region;

[0072] FIG. 55 shows a schematic, side cross-sectional view of another embodiment of a septum including at least one gel region;

[0073] FIG. 56 shows a schematic, side cross-sectional view of a further embodiment of a septum including at least one gel region;

[0074] FIG. 57 shows a side cross-sectional view of a first mold and a second mold, wherein a gel region is positioned between the first mold and the second mold;

[0075] FIG. 58 shows a schematic, side cross-sectional view of an embodiment of a septum including at least one chamber to capture a gel; and

[0076] FIG. 59 shows a schematic, side cross-sectional view of an additional embodiment of a septum including at least one gel region.

DETAILED DESCRIPTION

[0077] One aspect of the instant disclosure relates to vascular access ports. More particularly, in one embodiment, the instant disclosure contemplates that a vascular access port may be structured for accommodating a fluid flow rate of at least about 1 milliliter per second. Further, the instant disclosure contemplates that a vascular access port may be structured to withstand at least about 180 pounds per square inch (psi) of pressure developed within the reservoir defined by the septum and the access port housing. In one embodi-

ment, an access port may be structured for operating within a range of pressures of about 80 psi to about 180 psi. Such an access port may be advantageous for use in infusing a fluid into a patient (e.g., infusing contrast media into a patient for CT or MR imaging).

[0078] Generally, an access port may comprise a housing that captures a septum that may be repeatedly pierced or punctured with a hollow slender element (e.g., a cannula, or needle), which can include a Huber needle, a trocar with a circumferentially disposed cannula, or any other suitable access mechanism, without limitation. The words “cannula” or “needle,” as used herein, encompass any slender element (e.g., a cannula, a needle, a trocar, with a circumferentially disposed cannula, etc.) as known in the art or described herein, without limitation. Such a septum may comprise a material (e.g., silicone) that seals, under suitable compression, passages formed by puncturing the septum with such an access mechanism. Thus, the septum may be at least partially compressed to facilitate closure of passages formed by puncturing the septum with the access mechanism. The instant disclosure contemplates that the housing and septum may be structured so that a flow rate from the reservoir of the access port may be at least about 1 milliliter per second without damaging the housing or septum or compromising the structural integrity of the reservoir (e.g., causing the septum to become separated from the housing).

[0079] In one embodiment, an access port may comprise a cap and base which define, in combination, a housing in which a septum may be positioned to form a reservoir. For example, FIGS. 1 and 2 show, respectively, an exploded perspective view and a side cross-sectional view of an access port 50 including a base 56, a cap 54, a septum 80, and an outlet stem 70. As shown in FIGS. 1 and 2, cap 54 and base 56, may be configured for capturing a septum 80 between cap 54 and 56. Generally, cap 54 and base 56 may collectively form a housing 60 for capturing septum 80 and at least partially defining reservoir 66. Explaining further, cap 54 may include an aperture 55 through which a portion of septum 80 may extend and base 56 may include a recess 57 configured to accept at least a portion of septum 80. Thus, a portion of septum 80 may be placed within recess 57 of base 56 and aperture 55 of cap 54 may be positioned about septum 80 to collectively define a reservoir 66 within access port 50, the reservoir 66 being in fluid communication with a lumen of outlet stem 70. In other embodiments, a plurality of reservoirs may be collectively defined by a housing and at least one septum, without limitation. For example, any access port known in the art including a plurality of reservoirs (or one reservoir) may include any aspects) of the instant disclosure, without limitation. As shown in FIG. 1, a portion of outlet stem 70 may be positioned within and coupled to an aperture 58 formed within base 56.

[0080] Although FIG. 1 shows that access port 50 may include an outlet stem 70, other embodiments of access port 50 may not include an outlet stem 70. Therefore, FIG. 2 shows access port 50 without an outlet stem 70. Put another way, the instant disclosure contemplates that access port 50 may, optionally, include an outlet stem 70 or may be otherwise configured. For instance, in one embodiment, outlet stem 70 may be formed as a part of with base 56, if desired. In another embodiment, a catheter may be operably coupled to the access port 50 (e.g., to aperture 58) without outlet stem 70. In yet a further embodiment, access port 50 may simply include at least one outlet passage (e.g., aperture

58) in fluid communication with the reservoir 66 and extending through the housing 60 and structured for allowing fluid flow through, if desired. As shown in FIG. 2, a portion of septum 80 may be positioned between cap 54 and base 56 and may be configured to withstand, without damage or deforming to an extent that compromises the reservoir 66 (i.e., blowing out), a selected magnitude of pressure developed within reservoir 66.

[0081] For example, as shown in FIGS. 1 and 2, cap 54 may optionally include a circumferential ring structure 30 that is formed adjacent to a side periphery of septum 80. Ring structure 30 may be structured to inhibit deformation of the cap 56 in response to a pressure developed within reservoir 66 of access port 50. As shown in FIG. 3, in a top elevation view of cap 54, ring structure 30 may be generally circular. Further, ring structure 30 may be substantially congruent to a side peripheral shape of septum 80 or may exhibit a different shape than the side periphery of septum 80. In addition, the size of ring structure 30 may be selected to provide a selected rigidity to a region of cap 54 adjacent to of aperture 55 of cap 54. Such a configuration may inhibit deformation of the cap 54 in response to pressure developed within reservoir 66. For example, as shown in FIG. 2, a lateral thickness T_L , vertical thickness T_V , or both may be selected for providing a selected rigidity to a region of cap 54 adjacent to a periphery of septum 80 (i.e., adjacent to aperture 55). In one embodiment, the overall height H (FIG. 2) of access port 50 may be less than about 0.600 inches.

[0082] In other embodiments, ring structure 30 may be generally rectangular, generally triangular, generally oval, generally polygonal, or of another geometrical shape, without limitation. For example, FIG. 4 shows a top elevation view of a ring structure 30 that is generally triangular. Further, FIG. 5 shows a generally rectangular ring structure 30.

[0083] Explaining further, housing 60 of access port 50 may comprise a biocompatible material such as polysulfone, titanium, or any other suitably biocompatible material. Thus, cap 54 and base 56 may couple to one another generally along a mating line and may be secured or affixed to one another. More particularly, in one embodiment, both cap 54 and base 56 may comprise titanium and may be welded, brazed, soldered, or otherwise affixed to one another. Such a configuration may provide suitable mechanical strength for capturing septum 80 between cap 54 and base 56. Optionally, cap 54 and base 56 may be coupled to one another by at least one fastening element (e.g., at least one bolt, at least one screw, at least one rivet, etc.), at least one adhesive, or a combination of such coupling mechanisms. Similarly, in one embodiment, outlet stem 70 and base 56 may each comprise titanium and may be welded or otherwise bonded or coupled to one another.

[0084] In further detail, FIG. 6 shows an access port 50 implanted within a patient 67. In one embodiment, sutures may be used to affix the access port 50 within the patient 67, if desired. After the housing 60 is implanted in a patient 67, the upper surface of the septum 80 may be generally flush or aligned with the surface of the skin surface 76 of the patient 67 and may be repeatedly punctured for creating a percutaneous passageway from the exterior of the skin of the patient into the reservoir 66. The outlet stem 70 may create a fluid-communicative passageway extending from the reservoir 66 and through the outlet stem 70, catheter 73, and into the interior of the patient 67. Generally, catheter 73 may

be coupled to the outlet stem 70 for fluid communication with the reservoir 66 and for conducting fluid to a desired remote location from the reservoir 66 and within patient 67. In one embodiment, catheter 73 may extend from the access port 50 to at least partially within a vena cava of the patient. Such a configuration may allow for infusion of a contrast media proximate to the heart of a patient. Because such a contrast media may be harmful (e.g., radioactive or otherwise injurious) infusion directly into a vena cava of a patient may reduce an overall quantity of contrast media required to perform a selected imaging procedure.

[0085] As shown in FIG. 6, a cannula 90 may be inserted through the septum 80 and fluid may be injected into the reservoir 66. For example, fluid may be injected into reservoir 66 at a rate that causes pressure (i.e., a positive pressure) to be developed within reservoir 66. For example, a positive pressure, labeled "PR" in FIG. 6, may develop within reservoir 66 and may act upon the portion of septum 80 defining, in part, reservoir 66. Such a pressure PR acting on a portion of septum 80 may develop force upon the septum 80. Likewise, force may be developed on surfaces of the base 56 that are acted upon by pressure PR. In one embodiment, cap 54 may be coupled to base 56 and structured to suitably position septum 80 and couple septum 80 to housing 60 against force applied to the septum 80. Therefore, the septum 80, cap 54, and base 56 may be structured for accommodating attendant forces developed by pressure PR. In one embodiment, access port 50 may be structured for accommodating (without damage) a pressure PR of at least about 185 psi with reservoir 66. In another embodiment, access port 50 may be structured for accommodating (i.e., without damage) a range of pressures of about 37 psi to about 65 psi with reservoir 66.

[0086] In further detail, during power injection, a fluid flow F may be caused to flow through cannula 90. A fluid flow rate (depicted in FIG. 6 by arrows labeled "F") may be at least about 1 milliliter per second. In another embodiment, a fluid flow rate F may be between about 1 milliliter per second to about 5 milliliters per second. During power injection, a pressure P_i may be developed within cannula 90 may be at least about 30 psi. Accordingly, cannula 90 may be structured to withstand the forces associated with the above-discussed pressure, flow rate, or both. As discussed in further detail below, the cannula may comprise a portion of an infusion set (e.g., a safety winged infusion set (SWIS)) or another infusion system configured for use with an access port and a power injection system, without limitation.

[0087] More particularly, FIG. 7 shows a graph depicting pressure measurements at different locations within an infusion system including an infusion set (as discussed in greater detail below) in fluid communication with an access port during infusion of a fluid at a rate of 5 milliliters per second. As shown in FIG. 7, a pressure generally within a syringe barrel of a power injector may be about 265 psi. Further, a pressure generally at the entrance of an infusion set may be about 225 psi and a pressure generally within a reservoir of an access port may be about 40 psi. Thus, the pressure drop through an infusion set may be about 185 psi. As shown in FIG. 7, a pressure generally at the distal end of a catheter extending from the access port may be about 0 psi. Many factors may influence a pressure (and a pressure drop) developed within an infusion system (e.g., infusion set, access port, etc.) during flow of a fluid through the infusion system, such as, for example, fluid viscosity, tubing inner

diameter (i.e., lumen cross-sectional size), length of the flow path, and flow rate. Accordingly, as will be appreciated by the above discussion of the access port 50 shown in FIGS. 1-3, such access port 50 may be structured to accommodate a selected flow rate and associated pressure PR developed within reservoir 66 of access port 50.

[0088] In another embodiment, the septum, housing, or both may be structured to mechanically secure or constrain at least a portion of the septum. For example, in one embodiment, the septum may include at least one coupling feature configured to mate or couple with a complementary coupling feature included by the housing. For example, male and female features (e.g., without limitation, ribs, flanges, interlocking features, tenon and mortise type features, tongue-in-groove features, T-slot features, dovetail features, snap-fit features, tabs and slots or other coupling features as known in the art) may comprise the at least one coupling feature included by the septum and the at least one complementary feature included by the housing, without limitation. “Tenon,” as used herein, means a projecting member for at least partial insertion into a mortise to make a joint. “Mortise,” as used herein, means a recess, hole, groove, or slot formed within a material for receiving at least a portion of a tenon to make a joint.

[0089] Generally, in one embodiment, the septum may include at least one tenon region (i.e., at least one coupling feature) for coupling to a complementary mortise region formed by the housing. Thus, the housing may include a recess (i.e., at least one complementary feature) for accepting at least a portion of the tenon region of the septum. For example, FIG. 8 shows a side cross-sectional view of one embodiment of a septum 180 including a tenon region 270. Particularly, tenon region 270 includes tapered surface 187 of septum 180, which may increase in height (i.e., from lower surface 183 of septum 180) along an increasing radial direction (i.e., relative to a radial distance from a central axis of septum 180; that is, in a direction from rim 159 of cap 154 toward side surface 157 of base 156). Thus, as shown in FIG. 8, a height CG_{MIN} of septum 180 (measured at a radially innermost extent of tenon region 270) is less than a height CG_{MAX} of septum 180 (at a radially outermost extent of tenon region 270). Further, tenon region 270 may be a continuous peripheral feature (i.e., an annular feature) of septum 180 or may comprise one or more circumferentially separate regions, without limitation. Further, as shown in FIG. 8, housing 160 (including cap 154 and base 156) may generally define a complementary mortise region (e.g., a circumferentially extending recess) for accepting at least a portion of tenon region 270. More particularly, a complementary mortise region may be defined by side surface 157 of base 156, lower flange surface 273 of base 156, and tapered surface 172 of cap 154. Such a configuration may secure, capture, or retain a portion of tenon region 270 of septum 180 within the mortise region of housing 160 even if a selected maximum pressure is developed within reservoir 166 of access port 150.

[0090] In another embodiment, an access port may comprise a septum including a tenon region including a plurality of tapered surfaces. For example, FIG. 9 shows a schematic side cross-sectional view of a septum 180 including a tenon region 270 comprising tapered surface 187, tapered surface 189, and tapered surface 191. Further, as shown in FIG. 9, housing 160 may generally define a complementary mortise region tapered recess for accepting at least a portion of tenon

region 270. More particularly, a complementary mortise region may be defined within housing 160 by side surface 157 of base 156, lower flange surface 273 of base 156, tapered surface 172 of cap 154, tapered surface 193 of base 156, and tapered surface 195 of cap 154. Such a configuration may secure, capture, or retain at least some of tenon portion 270 of septum 180 within a tapered recess of housing 160 even if a selected maximum pressure is developed within reservoir 166 of access port 150.

[0091] In summary, it should be understood that a portion of a septum may comprise, generally, at least one tenon region for coupling with a complementary mortise region formed in a housing. In another embodiment, generally, at least a portion of a housing may comprise a tenon for coupling with a complementary mortise formed in a septum. As described above, a tenon region and a complementary mortise region may comprise one or more tapered surfaces. In another embodiment, a tenon region and complementary mortise region may comprise a T-slot or other nontapered geometry, without limitation. For example, FIG. 10 shows a schematic, side cross-sectional view of one embodiment of an access port 150 comprising a septum 180 including a tenon region 270. Further, a complementary mortise region may be defined within housing 160 for accepting at least a portion of tenon region 270. As shown in FIG. 10, a mortise region may be at least partially defined by an annular extension or protrusion 203 of base 156. Such a configuration may secure, capture, or retain at least a portion of tenon region 270 of septum 180 within housing 160 and suitably seal reservoir 166 even if an anticipated maximum pressure is developed within reservoir 166. It should be further understood that any of the tenon region and mortise region embodiments shown in FIGS. 8-10 may be described in terms of extensions, ridges, protrusions, recesses, grooves, slots, etc., without limitation.

[0092] A further aspect contemplated by the instant disclosure relates to coupling or affixing at least a portion of a peripheral region of a septum to a housing. Such a configuration may maintain the integrity of the access port during use of the access port for infusing a fluid at a flow rate of at least about 1 milliliter per second. For example, in one embodiment, at least a portion of a side periphery of a septum may be affixed to at least a portion of a housing. FIG. 11 shows a side cross-sectional view of an access port 50 wherein at least a portion of a periphery of septum 80 adjacent to housing 60 is affixed to one or both of cap 54 and base 56 adjacent to septum 80. More particularly, as shown in FIG. 11, a periphery of septum 80 (adjacent to cap 54 and base 56) may include upper side region 97, upper annular region 93, lower annular region 91, and lower side region 95. Thus, in one embodiment, an adhesive, (e.g., glue, epoxy, cement, tape, or any other adhesive as known in the art) may affix at least a portion of one or more of upper side region 97, upper annular region 93, lower annular region 91, and lower side region 95 to the cap 54 or base 56, respectively. Such a configuration may secure septum 80 to housing 60 and may provide a relatively robust access port 50 suitable for power injection. It should further be appreciated that affixing at least a portion of a peripheral region of a septum may encompass affixing at least a portion of a tenon region (of either a septum or housing) to a mortise region (of either a housing or septum), without limitation.

[0093] As described above, septum deformation is a design consideration with respect to performing power

injection via an access port. Further, one aspect of the instant disclosure relates to a septum that is structurally reinforced or otherwise limited against deformation exceeding a selected magnitude. More specifically, the instant disclosure contemplates that at least one structural element may be configured to inhibit or limit deformation of a septum of an access port in response to pressure developed within a chamber or reservoir of the access port. Some embodiments of an access port including at least one structural element for limiting deformation of a septum are disclosed in U.S. Patent Application No. 60/737,466, filed Nov. 15, 2005, the disclosure of which is incorporated, in its entirety, by this reference. Any of the access ports encompassed by U.S. Patent Application No. 60/737,466 may be structured for power injection.

[0094] In one embodiment, the instant disclosure contemplates that a septum may be structurally coupled to a housing nonperipherally. Put another way, one aspect of the instant disclosure relates to coupling a nonperipheral portion of a septum to a housing of an access port. For example, FIG. 12 shows one embodiment of an access port 110 according to the instant disclosure including a cap 54 and a base 56 that capture a septum 120 to form a reservoir 66. Optionally, cap 54 may include a ring feature proximate to a periphery of the septum, as described above. In addition, outlet stem 70 may allow for fluid communication with reservoir 66 to perform infusion or fluid sampling processes. As shown in FIG. 12, a structural element 112 may extend between septum 120 and housing 60. More particularly, structural element 112 extends generally from lower surface 121 of septum 120 to upper surface 165 of base 56. Thus, if pressure (positive/negative) is developed within reservoir 66, structural element 112 may inhibit deflection or deformation of lower surface 121 of septum 120 toward or away from upper surface 165 of base 56. Generally, a structural element may inhibit deformation of a septum in relation to one or more selected directions (i.e., either toward or away from upper surface 165 of base 56).

[0095] Generally, a structural element (e.g., structural element 112) may comprise any of the following: at least one wire, at least one pin or columnar element, or at least one filament, without limitation. Such a structural element may comprise titanium, steel (e.g., stainless steel), polymers (e.g., DELRIN®, nylon, polyester, KEVLAR®, polytetrafluoroethylene (PTFE) (expanded or nonexpanded), polyurethane, etc.), or other materials as known in the art. In other embodiments, a structural element may comprise a composite, such as a fiber-reinforced matrix. In one embodiment, a structural element may comprise fibers (glass, carbon, etc.) dispersed or aligned within a silicone matrix.

[0096] Further, structural element 112 may be coupled to septum 120 by an adhesive, welding, snap-fitting, molding the septum 120 about a portion of the structural element 112, otherwise imbedding a portion of structural element 112 within septum 120, or as otherwise suitable. Similarly, structural element 112 may be coupled to base 56 by an adhesive, welding, or imbedding a portion of structural element 112 within base 56. It may also be appreciated that, optionally, structural element 112 may exhibit a modulus of elasticity that exceeds a modulus of elasticity of septum 120. Such a configuration may allow for structural element 112 to resist deformation of septum 120 in response to a pressure developed within reservoir 66 (e.g., during a “power injection” process).

[0097] FIG. 13 shows a schematic cross-sectional view of an access port 110 according to the instant disclosure including another embodiment of structural element 112. Particularly, as shown in FIG. 13, structural element 112 may include a barbed end 116, which is positioned at least partially within septum 120. Such a configuration may couple structural element 112 to septum 120 and may resist against deformation of the septum 120 in response to pressure developed within reservoir 166. Furthermore, as shown in FIG. 13, the barbed end 116 of structural element 112 may, optionally, be pointed. Further, the point of barbed end 116 may be oriented toward upper surface 123 of septum 120. Such a structure may deflect a cannula that is inserted through septum 120 and contacts barbed end 116 so that the cannula is directed away from structural element 112. Optionally, in another embodiment, structural element 112 may extend through base 56 and may be affixed to lower surface 113 of base 56.

[0098] In another embodiment of an access port, a structural element may extend through a septum. For example, FIG. 14 shows a schematic, side cross-sectional view of an access port 110 including a structural element 112 that extends from lower surface 121 of septum 120 to upper surface 123 of septum 120. As shown in FIG. 14, structural element 112 may also extend to upper surface 165 of base 56, to mechanically couple septum 120 to housing 60. Optionally, structural element 112 may include at least one barb, which may be positioned within septum 120 and configured for coupling septum 120 to housing 60. In addition, structural element 112 may be affixed, if desired, to at least one of upper surface 123 and lower surface 121 of septum 120. As may be appreciated, it may be advantageous for upper surface 123 of septum 120 to be mechanically coupled to housing 60 to resist deformation of septum 120 in response to a pressure developed within reservoir 66.

[0099] The instant disclosure further contemplates that a structural element may be employed in combination with a support element extending over a selected area of the upper surface of the septum. Such a support element may be positioned adjacent to an upper surface of a septum and may be configured to contact the upper surface of the septum with a selected surface area (e.g., when the septum deforms). For example, FIG. 15 shows a schematic, side cross-sectional view of an access port 110 including a structural element 112 that extends from housing 60 to an upper surface 123 of septum 120. Furthermore, structural element 112 is coupled to a support element 114, which is positioned adjacent to upper surface 123 of septum 120. Such a configuration may provide a selected amount of contact area between support element 114 and upper surface 123 of septum 120. Such a selected contact area between support element 114 and septum 120 may reduce otherwise undesirably high stresses within septum 120 when a pressure develops within reservoir 66 by distributing such stresses over a selected area or region of septum 120. In addition, support element 114 may be observable (e.g., visually or by palpation) and, therefore, may be avoided when inserting a cannula through septum 120. Additionally, the support element 114 can be used to identify the port 110 as being power injectable.

[0100] In another embodiment of an access port, a structural element may comprise a portion of a septum affixed to a housing of an access port to resist deformation of the septum. For example, FIG. 16 shows a schematic, side cross-sectional view of an access port 110 including a

septum 120, which comprises an extension leg 124 (i.e., a structural element) that is coupled to housing 60. More particularly, as shown in FIG. 16, extension leg 124 may extend generally from lower surface 121 of septum 120 to upper surface 165 of base 56. Extension leg 124 may abut and may be affixed to upper surface 165 of base 56. Such a configuration may resist against deformation of septum 120 in response to pressure developed within reservoir 166. In one embodiment, extension leg 124 may be substantially centered (i.e., positioned generally at a centroid of lower surface 121) with respect to lower surface 121 of septum 120. Substantially centering extension leg 124 with respect to lower surface 121 of septum 120 may limit deformation of lower surface 121 of septum 120 to a greater extent than other positions of extension leg 124 may limit deformation of lower surface 121 of septum 120. Additionally, it should be appreciated that while FIG. 16 shows one extension leg 124, the instant disclosure contemplates that at least one extension leg (i.e., one or more extension legs) may extend from or be coupled to septum 120, without limitation. In another embodiment, at least one extension leg may be coupled to a housing of an access port by an interference fit or a so-called “snap-fit.” More particularly, as shown in FIG. 17, extension leg 124 includes a bulbous or rounded end 125 that is configured to fit within a recess 155 formed in base 56. Recess 155 may comprise an opening formed in upper surface 165 of base 56 that is smaller than a maximum lateral dimension of rounded end 125, so that rounded end 125 may be forced through such an opening and “snap” into a portion of recess 155. Optionally, extension leg 124 may be affixed (e.g., adhesively affixed, welded, pinned, or affixed by other suitable methods) to recess 155 formed in base 56. Such a configuration may couple septum 120 to base 60 of access port 110 and may resist or limit deformation of septum 120 in response to pressure developed within reservoir 66.

[0101] Another aspect of the instant disclosure contemplates that at least a portion of an upper surface of a septum may be constrained or limited in its deformation. In one embodiment, at least one structural element may be positioned upon or adjacent to an upper surface of a septum to limit deformation of the septum in a direction toward the structural element. Put another way, at least one structural element may extend laterally upon or adjacent to at least a portion of an upper surface of a septum. For example, FIG. 18 shows a schematic, side cross-sectional view of an access port 110 including a septum 130 and a structural element 132 positioned adjacent to an upper surface 133 of septum 130. Optionally, structural element 132 may be bonded or affixed to upper surface 133 of septum 130. Structural element 132 may be structured to resist deformation of septum 130 in a direction generally away from reservoir 166. In one embodiment, structural element 132 may substantially overlay or cover upper surface 133 of septum 130. Optionally, structural element 132 may be at least partially embedded within septum 130. In one embodiment, structural element 132 may be penetrable by a cannula (e.g., a needle). In another embodiment, structural element 132 may cover a selected portion (i.e., at least a portion) of upper surface 133 of septum 130, which may allow for openings or apertures formed in structural element 132 through which a cannula may be inserted into upper surface 133 of septum 130. It may be appreciated that, optionally, a modulus of elasticity of structural element 132 may exceed a modulus of elasticity

of septum 130, so that deformation of septum 130 may be inhibited to a selected degree by structural element 132. Further, although a thickness (labeled “t”) of structural element 132 is shown in FIG. 18 as being substantially uniform, the instant disclosure contemplates that a thickness “t” of structural element 132 may vary, without limitation. For example, thickness “t” of structural element 132 may be maximum proximate to a centroid of the upper surface 133 of septum 130. In addition, as shown in FIG. 18, structural element 132 may be positioned between cap 54 and septum 130. Structural element 132 may be affixed to one or both of cap 54 and septum 130, if desired. For example, structural element 132 may be adhesively affixed, welded, mechanically fastened, or otherwise suitably coupled to one or both of cap 54 and septum 130. Furthermore, structural element 132 may comprise a metal (e.g., titanium, steel, etc.), a polymer (e.g., DELRIN® polyurethane, nylon, etc.), or any other suitable material. In another embodiment, as discussed further below, structural element 132 may comprise a relatively tightly woven fabric that resists tissue ingrowth (if positioned in potential contact with an internal cavity of the body). In a further embodiment, a structural element 132 may comprise a substantially fluffy or compressible polyester that may promote tissue healing of punctures created by a cannula passing through septum 130 of access port 110 (if positioned in potential contact with an internal cavity of the body).

[0102] In a further embodiment, the instant disclosure contemplates that at least one structural element may be at least partially embedded within a septum and may extend laterally through at least a portion of the septum. For example, FIG. 19 shows a schematic, side cross-sectional view of an access port 110 including a septum 120 and a structural element 140 extending laterally (i.e., across an opening in the housing 60 closed by the septum 120) through the septum 120. As shown in FIG. 19, structural element 140 may be affixed to housing 60 (e.g., cap 54 or base 56). More particularly, as shown in FIG. 19, structural element 140 may be affixed to cap 154 at connection regions 147 and 143. In addition, a selected level of tension may be developed within structural element 140, if desired, to provide for a desired level of resistance to deformation (i.e., flexibility) of septum 120. Such a configuration may provide a selected degree of resistance to deformation of septum 120 in a direction generally perpendicular to a direction of extension of structural element 140.

[0103] In another embodiment, a structural element may be positioned proximate to an upper surface of a septum to limit deformation of the septum. For example, FIG. 20 shows a schematic, side cross-sectional view of an access port 110 including a septum 130 positioned within a housing 60 and a structural element 150 positioned proximate to an upper surface 133 of septum 130. As shown in FIG. 20, structural element 150 extends laterally over at least a portion of upper surface 133 of septum 130. Thus, structural element 150 may allow septum 130 to deform a selected distance (e.g., a gap labeled “G”) prior to contact with structural element 150. Further, structural element 150 may be affixed to cap 54 and may be selectively tensioned to exhibit a selected degree of flexibility in response to contact between septum 130 and structural element 150. In one embodiment, structural element 150 may exhibit a flexibility

or spring constant that exceeds a bulk flexibility or spring constant of septum 130 in response to a pressure developed within reservoir 66.

[0104] In another embodiment, a structural element may be positioned proximate to or abutting a lower surface of a septum to limit deformation of the septum. For example, FIG. 21 shows a schematic, side cross-sectional view of an access port 110 including a septum 120 positioned within a housing 60 and a structural element 170 positioned proximate to a lower surface 121 of septum 120. As shown in FIG. 21, structural element 170 may extend laterally over at least a portion of lower surface 121 of septum 120. Further, structural element 170 may be affixed to lower surface 121 or septum 120 or otherwise coupled to lower surface 121 of septum 120. Thus, structural element 170 may inhibit deformation of septum 120. Further, structural element 170 may be affixed to base 56 (or otherwise coupled to housing 60) to provide adequate resistance to deformation of septum 120. Optionally, structural element 170 may be selectively tensioned to exhibit a selected flexibility in response to forces applied to the structural element 170. Optionally, structural element 170 may exhibit a flexibility or spring constant that exceeds a bulk flexibility or spring constant of septum 120.

[0105] Referring to FIGS. 18-21, it will be appreciated that structural elements 132, 140, 150, or 170 may comprise, in some embodiments, elongated elements, such as, for instance, wire, ribbon, thread, fibers, columnar elements, or the like. Accordingly, such at least one elongated element may be arranged in a selected pattern adjacent or proximate to an upper surface of a septum. Further, in one embodiment, a structural element positioned proximate to or abutting a lower surface of a septum, proximate to or abutting an upper surface of a septum, or within a septum, may comprise a mesh (e.g., a metal or plastic mesh, a fabric, a fiber mesh, etc.). For instance, in one embodiment, a structural element may comprise a fabric comprising fibers or threads that seal against one another (e.g., fibers or threads coated with silicone). Such a configuration may allow for a cannula to pass through the fabric and for the fabric to seal about the cannula, but may also allow for the fibers or threads to seal against one another when the cannula is removed. In addition, it will be understood that, based upon the instant disclosure, structural elements 132, 140, 150, or 170 as shown in FIGS. 18-21 may be arranged in a variety of configurations.

[0106] For example, FIG. 22 shows a partial top elevation view of one embodiment of an access port 110, as shown in FIGS. 18-21, wherein structural elements 132, 140, 150, 170 are arranged to form a generally triangular shape or pattern. In a further example, FIG. 23 shows a partial top elevation view of an access port 110 as shown in FIGS. 18-21, wherein structural elements 132, 140, 150, 170 are arranged in two partially intersecting generally rectangular shapes or pattern. In yet a further embodiment, FIG. 24 shows a partial top elevation view of an access port 110, as shown in FIGS. 18-21, wherein structural elements 132, 140, 150, 170 are arranged as a pattern comprising a first plurality of substantially parallel lines and a second plurality of substantially parallel lines, wherein the first plurality of substantially parallel lines is substantially perpendicular to and intersects with the second plurality of substantially parallel lines. In an additional embodiment, FIG. 25 shows a partial top elevation view of an access port 110, as shown in FIGS. 18-21,

wherein structural elements 132, 140, 150, 170 are arranged as a pattern comprising two substantially straight (i.e., linear) members that intersect with one another. As shown in FIG. 25, structural elements 132, 140, 150, 170 may be substantially perpendicular to one another. As shown in FIGS. 22-25, structural elements 132, 140, 150, 170 may be affixed to cap 54 at selected connection regions. Such configurations may allow for varying degrees of limitation of deformation of a septum, while allowing ample access to a surface of a septum for perforation by a cannula (e.g., a needle).

[0107] In another embodiment, the instant disclosure contemplates that a structural element may be at least partially embedded within a septum and may be in the form, configuration, or shape of a two-dimensional or plane (e.g., a circle, ellipse, triangle, rectangle, etc.) within the septum. For example, FIG. 26 shows a partial top elevation view of a septum 120 and a structural element 141 extending within the septum 120. In further detail, FIG. 27 shows a perspective view of a sectioned septum 120 including a structural element 141 embedded within the septum 120. As shown in FIGS. 26 and 27, in one embodiment, structural element 141 may be generally circular. More generally, one or more structural elements 141 may be at least partially embedded within a septum (e.g., a septum 120 or 130, as discussed above), if desired. For example, a plurality of structural elements 141 may be embedded within a septum 120 and arranged substantially concentrically with respect to one another, as shown in FIG. 28 in a partial, top elevation view. Structural element 141 may be generally elongated (as shown in FIGS. 26-28) or may, more generally, exhibit a shape and size configured to resist deformation of the septum 120, without limitation. Thus, it should be appreciated that one or more structural elements 141 may embody, for example, a washer or a disk that is frustoconical, domed, or otherwise shaped. In another embodiment, at least one structural element 141 may form, generally, a toroid. Further, at least one structural element 141 may exhibit at least one selected characteristic (e.g., exhibiting a selected size, shape, elasticity, strength, etc.) to impart a desired level of resistance to deformation (i.e., flexibility) of septum 120. Such a configuration may provide a selected level of resistance to deformation of septum 120 in response to a pressure developed within a reservoir of an access port.

[0108] In another aspect of the instant disclosure, a septum may exhibit a curvature that resists deformation in response to a pressure developed within a reservoir of an access port. For example, FIG. 29 shows a septum 120 including a generally concave upper surface 123 and a generally convex lower surface 121. Explaining further, generally concave upper surface 123 and a generally convex lower surface 121 may be exhibited by septum 120 in the absence of external forces (i.e., in an unstressed, equilibrium state). Such a configuration may provide resistance of the septum 120 to deformation due to a pressure developed within reservoir 66 of access port 110, because the upper surface 123 of septum 120 would be forced to flatten (i.e., via deformation of septum 120) before extending beyond the upper surface of housing 60. In other embodiments, a septum may be compressed (e.g., by way of a tenon and mortise coupling or another peripheral coupling configuration between a septum and a housing) so that a curvature of the septum may be reduced or eliminated when the septum is assembled within the housing. However, such a configuration may increase the

bulk flexibility or spring constant of the septum. Optionally, a structural element (as described above) may be included within the septum or upon a surface of the septum and may also be fabricated to exhibit concavity or convexity in the absence of external forces. Such a configuration may facilitate a favorable compressive stress field within the septum when coupled to a housing and may enhance resistance of the septum to deformation.

[0109] In a further configuration, a septum may include a structural frame or skeleton and a more pliant material configured to seal punctures created by a cannula. More specifically, a frame may comprise a material with a shore A hardness of at least about 80. Optionally, a frame may include a plurality of whiskers, fibers, or particles to stiffen or strengthen the frame. In one embodiment, nylon fibers, barium sulfate, or the like may be dispersed within a frame. Further, such a frame may be at least partially surrounded by a more pliant material exhibiting a Shore A hardness of about 50 or less (e.g., a Shore A hardness of about 40 to about 50). FIG. 30 shows top elevation view of a frame 178 including a plurality of spokes 179 extending from a generally common origin or region as well as rings 181 and 185. As shown in FIG. 30, spokes 179 in combination with one or both of rings 181 and 185 form apertures 188. According to the instant disclosure, a relatively pliant material configured to seal punctures formed by a cannula passing through the material may at least partially surround such a frame 178. For instance, FIG. 31 shows a schematic side cross-sectional view of septum 177 comprising a frame 178 and another material 190 molded partially about frame 178. Thus, material 190 may substantially surround spokes 179 and may extend within apertures 188. Further, as shown in FIG. 31, ring 181 may form a tenon region 270 for coupling with a housing (as described above) as well as an upper septum surface 191 and a lower septum surface 193. As may be appreciated with reference to shown in FIG. 31, during use, a cannula may pass through a continuous upper layer of material 190 and a continuous lower layer of material 190. Such a configuration may provide suitable sealing capability for septum 177. It will be appreciated that many variations are contemplated by the instant disclosure. For example, FIGS. 32 and 33 show side cross-sectional views of different embodiments of a septum 177 including a frame 178 and another material 190 at least partially surrounding the frame 178. Thus, a frame and a material at least partially surrounding the frame may exhibit arcuate or substantially planar surfaces and may be formed of selected thickness and comprising selected materials (e.g., silicone, etc.).

[0110] In a further aspect of a septum according to the instant disclosure, a septum may include a radiopaque material and may be configured to form a selected pattern when an x-ray is taken through the septum. For example, FIGS. 34 and 35 show schematic views of patterns 199 that may be generated by correspondingly positioned radiopaque material within a septum. Such a configuration may be useful for identifying the access port as being capable of accommodating particular power injection processes or for locating the septum of an access port.

[0111] The instant disclosure further contemplates that any infusion apparatus or device that is used in combination with an access port for infusing fluid at a rate of at least about 1 milliliter per second may be configured accordingly. For example, an infusion set for accessing a vascular access port may include a needle or cannula for puncturing a septum of

the access port, a distal end for coupling to an injection apparatus, and tubing (e.g., at least one tubing section) extending between the cannula and the distal end. Generally, any components comprising an infusion set may be configured to withstand a selected flow rate and associated pressure developed by such a selected flow rate.

[0112] FIG. 36 shows one embodiment of an infusion set 310 including a base member 340, a cannula 350, a tubing section 314, and connector 312. Tubing 314 may be affixed or otherwise coupled to connector 312 and base 342 generally at joints 313 and 339, respectively. Also, as shown in FIG. 36, a clamp device 316 may be suitably configured for allowing or preventing fluid flow through tubing 314. Further, each of the base member 340, cannula 350, tubing section 314, and end connector 312 may be structured for accommodating a fluid flow rate of at least about 1 milliliter per second through the infusion set 310. In further detail, tubing section 314 may exhibit sufficient strength for withstanding at least about 200 psi without damage. Optionally, tubing section 314 may withstand at least about 300 psi without damage. Further a pressure at which a portion of the infusion set bursts (i.e., a burst pressure of the infusion set 310) may be at least about 400 psi; optionally, such a burst pressure may be at least 600 psi. In one embodiment, tubing section 314 may be substantially optically clear or may be at least partially transparent. In one embodiment, generally, tubing section 314 may comprise a polymer, such as TECOTHANE®. More specifically, tubing section may comprise a polymer, such as TECOTHANE® 55D or a polymer, such as TECOTHANE® 95A. For example, if tubing section 314 has an inner diameter (i.e., a lumen) of about 0.048 inches (± 0.003 inches) (i.e., 19 GA), tubing section 314 may comprise a polymer, such as TECOTHANE® 55D. In other examples, if tubing section 314 has an inner diameter (i.e., a lumen) of about 0.041 inches or 0.034 inches (± 0.003 inches) (i.e., 20 GA or 22 GA, respectively), tubing section 314 may comprise a polymer, such as TECOTHANE® 95A. Optionally, any polymer, such as TECOTHANE® type material may be at least substantially free of a plasticizer, such as, for instance, Di(2-Ethylhexyl)Phthalate ("DEHP"). In one embodiment, connector 312 may comprise polyvinylchloride ("PVC") and may be, optionally, at least substantially free of plasticizer. The materials disclosed above are merely examples; more generally, tubing section 314, connector 312, base member 340, and cannula 350 may comprise any material (e.g., thermoplastic, polyurethane, metal, etc.) suitable for providing a robust and effective infusion set 310.

[0113] During use of the infusion set 310, a mechanical injector may be operably coupled to connector 312 via fastening structure 311. For example, fastening structure may comprise a luer-type connection or any other fluid connection structure. Thus, a fluid may be flowed through the infusion set at a flow rate of at least about 1 milliliter per second via an injection apparatus. As discussed above, a pressure drop through the infusion set 310 may be at least about 100 psi; optionally, a pressure drop through infusion set 310 may be at least about 185 psi.

[0114] In another embodiment, an infusion set may include two connectors. In one configuration, one connector may be structured for performing power injection and another connector may be structured for allowing syringe access. For example, FIG. 37 shows an infusion set 309 including a base member 340, a cannula 350, a tubing

section 324, an intermediate connector 322, a tubing section 314, and an end connector 312. Tubing 314 may be affixed or otherwise coupled to connector 312 and connector 322 generally at joints 313 and 323, respectively. Similarly, tubing 324 may be affixed or otherwise coupled to connector 322 and base member 340 generally at joints 325 and 329, respectively. Infusion set 309 may be structured for fluid flow rates and pressures as discussed above in relation to infusion set 310. Accordingly, tubing sections 314 and 324 may comprise materials (e.g., a polymer, such as TECOTHANE® and sizes as discussed above in relation to infusion set 310, without limitation. Similarly, connectors 312 and 322 may comprise any materials (e.g., PVC) discussed above in relation to infusion set 310, without limitation. As shown in FIG. 37, a clamp device 316 may be suitably configured for allowing or preventing fluid flow through tubing 314. Likewise, clamp device 326 may be suitably configured for allowing or preventing fluid flow through tubing 324. In addition, connector 312 may include a fastening structure 311 (e.g., a luer connection, another threaded connection, or any other fastening structure as known in the art) for releasably affixing or coupling the connector 312 to an injection apparatus. Also, connector 322 may include a fastening structure 321 (e.g., a luer connection, another threaded connection, or any other fastening structure as known in the art) for releasably affixing or coupling the connector 322 to an injection apparatus.

[0115] Generally, the instant disclosure contemplates that, in one embodiment, connector 312 may be used for power injection, while connector 322 is capped. In another embodiment, a valve mechanism may selectively allow flow through tubing sections 314 and 324 via fluid flow through connector 312, while preventing leakage from connector 322. In addition, if infusion set 309 is not being used for power injection, a cap including a septum may be coupled to connector 322, connector 312, or both. Such a configuration may allow for a syringe to puncture the septum and infuse medication or remove a blood sample. Such a configuration may provide a convenient infusion set with separate connectors for power injection and syringe access, respectively.

[0116] In a further aspect contemplated by the instant disclosure, tubing that is used in connection with power injection may be structured for withstanding a selected pressure during use (e.g., power injection) and, optionally, may be configured to resist kinking. Generally, the instant disclosure contemplates that tubing may comprise a plurality of layers. In one embodiment, tubing may comprise a relatively high strength layer and at least one relatively flexible layer. Thus, any layers of tubing may comprise PTFE, polypropylene, polyetheretherketone (“PEEK”), polyimide silicone, fluorinated ethylene propylene (FEP), perfluoroalkoxy (PFA), ethylenetetrafluoroethylene (ETFE), polyurethane (e.g., thermoplastic polyurethanes, including ISOPLAST®, TECOFLEX®, TECOTHANE®, CARBOTHANE®, TECOPLAST®, or TECOPHILIC® type polyurethanes), or combinations of the foregoing. In one embodiment, the layers may be bonded to one or more adjacent layers. In another embodiment, each of the layers may be movable or slidable relative to one or more adjacent layers.

[0117] For example, FIGS. 38 and 39 show a side cross-sectional view and an end cross-sectional view of tubing 401 including an inner layer 420 and an outer layer 422. Gen-

erally, at least one of inner layer 420 and outer layer 422 may exhibit relatively high strength and the other of inner layer 420 and outer layer 422 may be relatively flexible or vice versa. In one embodiment, inner layer 420 may exhibit relatively high strength and may comprise, for example, PEEK, ULTEM®, polyimide, or the like. Further, outer layer 422 may be relatively flexible and may comprise, for example, FEP, PTFE, PEBAX®, ETFE, silicone or the like. Conversely, outer layer 422 may exhibit relatively high strength and may comprise, for example, PEEK, ULTEM®, polyimide, or the like, while inner layer 420 may be relatively flexible and may comprise, for example, FEP, PTFE, PEBAX®, ETFE, silicone, or the like. Further, optionally, tubing may comprise a first layer exhibiting a modulus of elasticity and at least another layer exhibiting a modulus of elasticity that is less than the modulus of elasticity of the first layer. For example, a relatively high strength material may exhibit a modulus of elasticity of at least about 400,000 psi. Furthermore, a relatively flexible material may exhibit a modulus of elasticity below about 390,000 psi. In another embodiment, at least one of layers 420 and 422 may comprise a composite material (e.g., a composite including particulate or fiber reinforcement). For example, in one embodiment, tubing may comprise polyurethane or PTFE including glass or carbon reinforcing fibers or particles. In one embodiment, each of the layers 420 and 422 may be movable or slidable relative to one or more adjacent layers. Such a configuration may withstand a selected internal pressure without damage to the tubing and may also resist kinking.

[0118] In another embodiment, a reinforcing element may be incorporated within at least one of the plurality of layers comprising tubing. For example, FIG. 40 shows a schematic side cross-sectional view of tubing 403 including inner layer 430 and outer layer 432, wherein at least one reinforcing element 434 is incorporated within outer layer 432. Optionally, at least one reinforcing element 434 may be incorporated within any layer or layers of a plurality of layers comprising tubing, without limitation. As shown in FIG. 40, reinforcing element 434 may comprise a coil, in one embodiment. One of ordinary skill in the art will appreciate that many variations are possible, for example, at least one reinforcing element may comprise a mesh (e.g., a wire mesh, a fabric, a fiber mesh, etc.). In another embodiment, at least one reinforcing member may comprise one or more elongated members extending longitudinally within at least one layer comprising tubing (e.g., aligned with the direction of extension of the tubing). In another embodiment, at least one reinforcing member may comprise one or more rings. Such a configuration may provide radial stiffness, strength, or both to a tubing section.

[0119] Referring to FIG. 40, in one embodiment, inner layer 430 may exhibit relatively high strength and may comprise, for example, PEEK or polyimide. Further, outer layer 432 may be relatively flexible and may comprise, for example, FEP, PTFE, ETFE, silicone, or polyurethane. Further, layers 430 and 432 may have a thickness (e.g., a radial thickness) of between about 0.005 inches and about 0.001 inches. As mentioned above, layers 430 and 432 may be bonded to one another or may be movable (slidable, twistable, etc.) with respect to one another. Optionally, a coating 433 may be applied to at least a portion of exterior surface of layer 432. Such a coating 433, in one embodiment, may

comprise a polymer, such as TEFLON® and may have a thickness of between about 0.001 inches and about 0.002 inches.

[0120] In a further embodiment, FIG. 41 shows a schematic side cross-sectional view of tubing 405, including inner layer 440 and outer layer 442, wherein at least one reinforcing element 444 is incorporated within inner layer 440. As shown in FIG. 41, reinforcing element 444 may comprise a coil, in one embodiment. In other embodiments, reinforcing element may comprise any structure discussed above in relation to reinforcing element 434, without limitation. In addition, in one embodiment, inner layer 440 may be relatively flexible and may comprise, for example, FEP, PTFE, ETFE, or polyurethane. Further, outer layer 442 may exhibit relatively high strength and may comprise, for example, PEEK or polyimide. Further, layers 430 and 432 may have a thickness (e.g., a radial thickness) of between about 0.005 inches and about 0.010 inches. Optionally, a coating 443 may be applied to at least a portion of exterior surface of layer 442. Such a coating 443, in one embodiment, may comprise a polymer, such as TEFLON® and may have a thickness of between about 0.001 inches and about 0.002 inches.

[0121] In an additional embodiment, tubing may include four layers. For example, FIGS. 42 and 43 show a cross-sectional end view and a side cross-sectional view of another embodiment of tubing 400. More particularly, as shown in FIGS. 42 and 43, tubing 400 includes layers 402, 404, 406, and 408. As shown in FIG. 42, layer 402 defines a lumen 410. In one embodiment, lumen 410 may have a substantially circular cross-sectional shape and may exhibit a diameter of about 0.024 inches. In another embodiment, each of the layers 402, 404, 406, and 408 may be movable or slidable relative to one or more adjacent layers. In addition, layer 402 may comprise a material exhibiting a relatively high tensile strength. Such a configuration may withstand relatively high pressures within lumen 410. For example, layer 402 may comprise PEEK, polyimide, etc. Typically, such relatively high strength materials may exhibit a modulus of elasticity of at least about 400,000 psi. Furthermore, each of layers 404, 406, and 408 may comprise a material that is relatively flexible. Such layers 404, 406, and 408 may each exhibit a tensile strength that is less than the tensile strength of layer 402. For example, each of layers 404, 406, and 408 may comprise a fluoropolymer, PEBAX®, polyethylene terephthalate (“PET”), silicone, etc. Typically, such relatively flexible materials may exhibit a modulus of elasticity below about 390,000 psi. However, any layers may comprise PTFE, polypropylene, silicone, FEP, PFA, ETFE, polyurethane (e.g., thermoplastic polyurethanes, including ISOPLAST®, TECOFLEX®, TECOTHANE®, CARBOTHANE®, TECOPLAST®, or TECOPHILIC® type polyurethanes), or combinations of the foregoing, without limitation.

[0122] In a further aspect of the instant disclosure, at least one layer comprising a tubing section may extend distally from a slender hollow structure for accessing a reservoir of an access port through a septum. Put another way, at least one layer may extend from a tubing section and may be structured for puncturing a septum of an access port. For instance, FIGS. 44 and 45 show a schematic side cross-sectional view of tubing 400, 401, 403, 405, and an access port 50. Tubing 400, 401, 403, 405 (as described above) includes a slender hollow region 450. Further, slender hol-

low region 450 may be relatively stiff and suited for penetrating a septum 80 of an access port 50, as shown in FIG. 45. Thus, a slender hollow region 450 extending from a distal end of tubing 400, 401, 403, 405 (which comprises a plurality of layers) may form a needle or cannula for fluid communication between a lumen of tubing 400, 401, 403, 405, and a reservoir 66 of access port 50. More particularly, a slender hollow region 450 may comprise one or more layers exhibiting a relatively high strength of relatively high-strength layers (e.g., PEEK) forming tubing 400, 401, 403, 405. In one embodiment, an innermost layer of tubing 400, 401, 403, 405 may form slender hollow region 450. Such a configuration may be advantageous and may, for example, reduce the complexity of manufacturing an infusion set.

[0123] Many different embodiments of vascular access apparatuses or infusion systems may incorporate one or more aspects of the instant disclosure. Some embodiments of a vascular access apparatuses or infusion systems are disclosed in U.S. Patent Application No. 60/675,309, filed Apr. 27, 2005, the disclosure of which is incorporated, in its entirety, by this reference. Any of the infusion systems, apparatuses, or methods, taken alone or in combination, described in U.S. Patent Application No. 60/675,309, may be structured or otherwise suited for performing power injection (e.g., accommodating a fluid flow rate of at least about 1 milliliter per second, without limitation).

[0124] For example, the instant disclosure contemplates that an infusion system configured for establishing fluid communication between a flexible tube and a reservoir of an access port may be structured for power injection. Such an infusion system may include a slender pointed element that facilitates placement of the flexible tube through a septum of the access port and is removable from the infusion system once the flexible tube is appropriately positioned.

[0125] Particularly, FIG. 46 shows in one embodiment an infusion system 510 in an exploded assembly view, including an insertion assembly 520, a safety clip 530, a hub 540 flexible tubing 590, extension tube 570, clamp device 560, and tube connector 580. In further detail, FIG. 47 shows a partial side cross-sectional view of infusion system 510. As shown in FIG. 47, insertion assembly 520 comprises a base 528 and a slender pointed element 522 (e.g., a needle, a trocar, or a cannula) secured thereto. As shown in FIG. 47, slender pointed element 522 includes a pointed end 525. In a particular embodiment, the instant disclosure may utilize a slender pointed element having a “non-coring” pointed end (i.e., pointed end 525 is not “open” or hollow) to avoid damaging a septum of a port into which the slender pointed element is inserted. The slender pointed element 522 may comprise any conventional needle, trocar, or cannula material, such as a stainless steel (e.g., AISI 304 stainless steel), or may, in another embodiment, comprise a relatively hard plastic. In one embodiment, base 528 may be injection molded or otherwise formed about slender pointed element 522 to capture a portion of the slender pointed element within the base 528, as best seen in FIG. 47. Further, base 528 may optionally include a recess 524 structured for accommodating other mechanisms (e.g., safety clip 530), if such a recess is desirable. Base 528 may also, optionally, include a coupling feature 526 (e.g., a protrusion) structured for coupling to a coupling feature 544 (e.g., a recess) formed in hub 540. Hub 540, as shown in FIG. 47, may generally include hub body 550, manifold element 561, septum 548

and cap 546. In one embodiment, hub body 550 may comprise TECOFLEX® (e.g., such as TECOFLEX® 85A-B20). Further, hub body 550 may define wing structures 541 and 543 (FIG. 46), which may be configured for affixing the hub to skin of a patient (e.g., by taping wing structures 541 and 543 to a patient, adhesively affixing wing structures 541 and 543 to a patient, or otherwise affixing wing structures 541 and 543 to a patient). Wing structures 541 and 543 may be employed for manipulation of the hub, such as, for example, when inserting the slender pointed element 522 and flexible catheter 590 into an implanted port or when removing the slender pointed element 522 from an implanted port. Hub body 550 may optionally include a recess 542, if such a recess is desirable. As shown in FIG. 47, recess 542 may have a retaining lip 559 for retaining safety clip 530 therein, while long slender element 522 is positioned through the safety clip, as discussed in further detail herein below.

[0126] Hub 540 may be structured for allowing the slender pointed element 522 of insertion assembly 520 to pass through the hub 540 and through septum 548, which is positioned within the hub 540. Put another way, manifold element 561 may define a plurality of passageways and at least one septum 548 through which fluid communication with the plurality of passageways may be accomplished. Explaining further, a manifold element 561 may be configured for housing septum 548 to provide a seal a port or opening of a plenum defined by manifold element 561. Optionally, a cap element 546 may be positioned to capture septum 548 between cap element 546 and manifold element 561. Cap 546 may include an aperture 547 for allowing a slender pointed element to pass therethrough and through septum 548. Thus, slender pointed element 522 (e.g., an appropriately sized trocar, non-coring needle, or non-coring cannula) may be inserted through and removed from septum 548 without compromising the ability of septum 548 to seal. Further, the presence of cap 546 may allow for so-called “power injection” to occur via manifold element 561, wherein pressures within manifold element 561, tubing 570, and flexible catheter 590 may reach at least about 200 psi or higher. Septum 548 may be structured according to any septum embodiments disclosed herein (e.g., including at least one structured element, for performing power injection, etc.), without limitation.

[0127] As shown in FIG. 47, flexible catheter 590 may be affixed to manifold element 561 and extension tube 570 may be affixed to manifold element 561. In one example, extension tube 570 and flexible catheter 590 may be chemically bonded to manifold element 561. In another example, an adhesive may affix extension tube 570 to surface 552 a part of manifold element 561. Similarly, an adhesive may affix flexible catheter 590 to inner surface 562 another part of manifold element 561. Further, the hub body 550 may be formed (e.g., injection molded, cured, or otherwise overmolded) over the manifold element 561 (and, optionally the septum 548, the cap 546, or both) and at least a portion of the extension tube 570 as shown in FIG. 47. In another embodiment, the hub body 550 may be formed over at least a portion of the flexible catheter 590, if desired.

[0128] Generally, as mentioned above, any tubing disclosed in the instant disclosure may comprise a portion of infusion system 510. Further, tubing clamps and connection devices as known in the art, may be employed for extension tubing 570, clamp device 560, and tube connector 580.

[0129] Flexible catheter 590 may comprise any material that is suitable for power injection. For example, in one embodiment, flexible catheter 590 may comprise a polymer, such as TECOTHANE® (e.g., TECOTHANE® TT1055 D). As shown in FIG. 47, flexible catheter 590 may include an elongated lumen therein. Further, flexible catheter 590 may have, proximate to opening 593 thereof, a transition region 595 wherein a cross-sectional size (transverse to the lumen 594) of the flexible catheter 590 increases as a function of increasing distance from opening 593. Optionally, transition region 595 may include two distinct tapers, although the instant disclosure contemplates more generally that at least one taper, at least one arcuate surface, or combinations thereof may define transition region 595. Generally, at least one aperture (e.g., one or more than one) may be provided proximate opening 593 that extends through the tubular body of flexible catheter 590 and communicates with lumen 594. As shown in FIG. 47, flexible catheter 590 may include two apertures 592 in fluid communication with lumen 594.

[0130] As shown in FIG. 47, slender pointed element 522 may extend through safety clip 530, through aperture 547 of cap 546, and into flexible catheter 590. Slender pointed element 522 may be structured for allowing fluid communication within flexible catheter 590. More particularly, slender pointed element 522 may be sized so as to allow for clearance between the exterior of the slender pointed element 522 and the interior (i.e., the lumen) of the flexible catheter 590. In one embodiment, slender pointed element 522 may include at least one longitudinally extending indentation (with respect to a nominal cross-sectional shape of the slender pointed element 522). For example, slender pointed element 522 may have a pointed end 525 and may include longitudinally extending indentations extending along (i.e., along a longitudinal axis of) slender pointed element 522. In another embodiment, slender pointed element 522 may be generally circular, and longitudinally extending indentations may form a substantially triangular cross section of the slender pointed element 522 over the portion of the slender pointed element that they are formed.

[0131] In a further embodiment, an infusion system may be structured so that a slender pointed element passes through an extension tube, a flexible catheter, or both. Explaining further, appropriate placement and configuration of a septum may allow for a slender pointed element to pierce or pass into an extension tube, a flexible catheter, or both. FIGS. 48 and 49 show another embodiment of a hub 540 including recess 542, sleeve 620, and septum 548. In addition, at least a portion of each of extension tube 570 and flexible catheter 590 may extend partially within hub body 550. Further, flexible catheter 590 extends partially within extension tube 570. Put another way, flexible catheter 590 may at least partially overlap with extension tube 570 and vice versa. In another embodiment, a single tubular element may extend through hub 540 and function as both the flexible catheter 590 and extension tube 570, if desired. Further, optionally, septum 548 may at least partially surround a portion of extension tubing 570. Such a configuration may facilitate sealing of septum 548 upon removal of slender pointed element 522 therefrom. Sleeve 620 may compress septum 548 so as to facilitate sealing of septum 548 upon removal of slender pointed element 522 from the region of the septum 620 that the sleeve 620 surrounds. Septum 548 may be structured according to any septum

embodiments disclosed herein (e.g., including at least one structured element, etc.) for performing power injection, without limitation.

[0132] Further, FIG. 50 shows a perspective view of safety clip 530 positioned generally about pointed end 525 of slender pointed element 522. Safety clip 530 includes legs 533 and 535 each having a curved end region, respectively, and a hole 534 sized for passing there through slender pointed element 522. In further detail, initially slender pointed element 522 may be passed through hole 534 and between legs 533 and 535 may be positioned and configured so as to allow the slender pointed element 522 to extend there past. Further, when the slender pointed 522 element is positioned therein and safety clip 530 is positioned within recess 542, safety clip 530 may be sized so that it will fit within the retaining lip 543 (FIG. 49) of recess 542 (FIG. 49). However, legs 533 and 535 may be biased so that if the pointed end 525 of the slender pointed element 522 is moved toward hole 534 and does not extend past the curved end regions of the legs 533 and 535, legs 533 and 535 will move toward one another to effectively capture the pointed end 525 of the slender pointed element 522. Safety clip 530 may comprise any self-actuating device for capturing a pointed end 525 of a slender pointed element 522. Such a safety clip 530 may reduce the chance of inadvertent insertion of the slender pointed element 522 into another person, particularly the medical practitioner that is installing and removing the slender pointed element 522.

[0133] The instant disclosure further recognizes that because the consequences of improperly pressurizing an access port (and a catheter affixed to the access port, if any) or an infusion set may be problematic, it may be advantageous to provide at least one identification attribute to components of an infusion system so that all of such components may be suitable for withstanding an anticipated maximum flow rate and pressure associated with a selected infusion process. Put another way, an access port that is configured for accommodating a flow rate of at least about 1 milliliter per second may include at least one identification attribute. Such an at least one identification attribute may be observed (e.g., visually, by palpation, ultrasonically, radiographically, etc.) or otherwise detected. The term, "identification," as used herein and in connection with any infusion devices (an access port, infusion set, etc.), means the ability to correlate selected information of interest with a perceivable feature.

[0134] The instant disclosure contemplates that any of the identification features or attributes, taken alone or in combination, described in U.S. Patent Application No. 60/658,518, filed 4 Mar. 2005, may identify an access port as being structured for power injection. Also, embodiments of an access port including at least one identification attribute are disclosed in U.S. Pat. No. 8,177,762, filed 28 Dec. 2005, the disclosure of which is incorporated, in its entirety, by this reference. The instant disclosure contemplates that any of the identification features or attributes, taken alone or in combination, described in U.S. Pat. No. 8,177,762 may identify an access port as being structured for power injection. Further, an access port may be identified by a maximum rate at which fluid may safely be infused. For example, at least one identification attribute may indicate that an access port is configured for accommodating a fluid flow rate of at least about 1 milliliter per second, without limitation.

[0135] Referring to an access port encompassed by the instant disclosure, at least one attribute of a housing of an access port may provide at least one identification attribute for identifying the access port as being structured for power injection at a rate of at least about 1 milliliter per second. In one embodiment, at least one physical attribute (e.g., size, shape, etc.) of an access port may identify the access port as suitable for power injection or may identify a maximum flow rate or pressure that may be safely accommodated by the access port.

[0136] Thus, one aspect of the instant disclosure relates to a method of identifying an access port (e.g., subcutaneously implanted or otherwise situated, without limitation) as being suited for power injection. More particularly, an access port including a septum may be provided. Further, at least one attribute of the access port may be perceived. In addition, the subcutaneously implanted access port may be identified as being suitable for power injection in response to perceiving the at least one attribute of the access port.

[0137] In one embodiment, at least one attribute for identification may comprise at least one feature of an access port housing. In further detail, FIG. 51 shows a perspective view of an assembled access port 50. As shown in FIG. 51, a side periphery 295 (e.g., one or more side walls and, optionally, exposed surfaces of suture plugs 291) of access port 50 may be generally triangular. Thus, cap 54 and base 56 may collectively form a generally triangular housing 60 of access port 50. Also, the instant disclosure contemplates that side periphery 295 may taper or arcuately extend between an upper surface 61 of cap 54 and lower surface 51 of base 56. As shown in FIG. 51, a transverse cross section (taken in a selected plane substantially parallel to lower surface 51, if planar, of base 56) of access port 50 may be larger proximate to lower surface 51 of base 56 and may be relatively smaller proximate to an upper surface of cap 54. FIG. 52 shows a top elevation view of the access port 50 shown in FIG. 52 and illustrates a generally triangular shape defined by side periphery 295. Additionally, FIG. 53 shows a simplified representation of a transverse cross section of access port 50. As shown in FIG. 53, side periphery 295 of access port 50 may define three side regions 303 that extend between associated vertex regions 301. In addition, in one embodiment and as shown in FIG. 53, side periphery 295 may define a substantially equilateral generally triangular shape. As may be appreciated, side regions 303 may arcuately extend between associated vertex regions 301; thus, side regions 303 may form "sides" of a generally triangular shape. Further, although vertex regions 301 are rounded, it will be appreciated that such vertex regions 301 form an intersection between adjacent side regions 303. Accordingly, it will be appreciated that the phrase "generally triangular," as used herein, encompasses any generally three-sided geometry wherein adjacent sides intersect at or within vertex regions, without limitation. For example, "generally triangular" encompasses three-sided polygons, circular triangles, equilateral triangles, etc., without limitation.

[0138] Furthermore, in a further embodiment, at least one attribute for identification may comprise a radiographic marker. More particularly, an access port may exhibit an observable pattern, symbol, marker, or other indicium that indicates that the access port is structured for accommodating a particular flow rate, pressure, or both. In another embodiment, at least one attribute for identification may comprise a perceptible aspect, such as a visually perceivable

feature. For example, at least one color, at least one symbol, at least one typographical character (e.g., a letter, a number, etc.), a pattern, or any other indicium that may be visually perceivable or otherwise perceptible may be used. In a yet additional embodiment, an ultrasound detectable feature may be incorporated within an access port. In a further additional embodiment, an access port may comprise an RFID tag.

[0139] It will be appreciated that other equipment and devices (e.g., infusion sets, tubing, injectors, etc.) may be identifiable in relation to a suitable maximum flow rate or maximum pressure. For example, particular infusion apparatuses may include one or more of the above-mentioned identification attributes or features. Such a configuration may allow for different components (e.g., tubing, needles, access ports, mechanical injectors, etc.) to be matched with one another. For example, substantially similar or matching identification attributes shared by a power injection apparatus, an infusion set, and an access port may indicate suitability for use with one another to perform a selected power injection process.

[0140] Another aspect of identification of an access port may relate to identification of a patient within which an access port is implanted. More specifically, a patient may be provided with an identification card that carries perceptible (e.g., visually, via magnetic strip, bar code, manually, or by other suitable mechanisms) information regarding an implanted port. Thus, such an identification card may be presented to a health care worker, the information carried by the identification card may be perceived, and the access port may be identified. Upon identifying the access port, characteristics of the access port may be ascertained, such as, for instance, a maximum flow rate, a maximum pressure, suitability for a particular procedure or procedures, etc. In another embodiment, a wristband or bracelet may be provided to a patient within whom an access port is implanted. In a further embodiment, a key chain including an information carrying device, such as, for example, a magnetic strip, a bar code, a computer readable media or device (e.g., a compact disk, "flash" memory, a disk drive, etc.), or any other suitable information carrying device. In another embodiment, a sticker containing the port information can be applied to the chart of the patient. In further embodiments, labeling on the infusion set can be used to identify the set as power injection compatible.

[0141] A further aspect of the instant disclosure relates to a septum comprising a gel or viscous liquid. The term "gel," as used herein, means a colloid with at least one solid component suspended within at least one liquid component, wherein the solid particles (e.g., polymer particles) are attracted or otherwise linked to one another (e.g., entangled or cross-linked) by covalent, ionic, or dispersion (physical) forces. Thus, in one embodiment, a gel may be a colloid in which the solid disperse phase forms a network in combination with the fluid continuous phase to produce a viscous or semi-rigid sol. A gel may exhibit stress-strain behavior that is elastic, viscoelastic, or plastic, without limitation. The term "viscous liquid," as used herein, means a liquid exhibiting a viscosity of about 20,000 centipoises or higher.

[0142] One or more passageways formed through a septum positioned within a housing to form an access port may allow for leaking of fluid through the one or more passageways if the reservoir of the access port is pressurized. The instant disclosure contemplates that a gel region may be

generally positioned between an upper surface of a septum and a lower surface of a septum, to facilitate a cannula extending through the septum from the upper surface to the lower surface to also pass through at least a portion of the gel region.

[0143] For example, in one embodiment, a septum may include a gel that is at least substantially surrounded by a body material. For instance, FIG. 54 shows a schematic, side cross-sectional view of a septum 610 including a body 612 and a gel region 620 positioned within body 612. Gel region 620 may be structured so that a cannula inserted through upper surface 614 and extending through lower surface 616 will pass through a portion of gel region 620. In one embodiment, gel region 620 may comprise a silicone gel. In another embodiment, a gel region may comprise an uncured liquid (i.e., has a relatively low viscosity) that may be cured to cause the liquid to form a gel. In a further embodiment, gel region 620 may comprise a viscous liquid, or a viscoelastic material.

[0144] In one example, gel region 620 may comprise an elastomer, such as, DOW CORNING® 7-9600 Soft Filling Elastomer, Parts A & B, which is commercially available from DOW CORNING Corporation of Midland, Mich. In another embodiment, gel region 620 may comprise Silicone Gel MED-6340, which is commercially available from NuSil Technology of Carpinteria, Calif. In yet a further embodiment, gel region 620 may comprise an elastomer exhibiting a Shore A hardness of about 20 to about 30, such as, for instance, DOW CORNING® C6-515 Liquid Silicone Rubber, Parts A & B or DOW CORNING® C6-530 Liquid Silicone Rubber Parts A & B, either of which is available from DOW CORNING Corporation of Midland, Mich. Further, optionally, body 612 of septum 610 may comprise a silicone material with a Shore A hardness of about 50 to about 60. In another embodiment, body 612 and/or upper surface 614 of septum 610 may comprise a silicone material with a Shore A hardness of about 60 to about 80. Optionally, body 612 and/or upper surface 614 of septum 610 may comprise a fluoropolymer (e.g., PTFE, etc.) or polyurethane.

[0145] One of ordinary skill in the art will understand that, upon removal of a cannula extending through at least a portion of gel region 620, a passageway or channel formed through gel region 620 may rebound, recover, seal, or heal. Further, gel region 620 may seal passageways formed through body 612 and upper surface 614. For example, gel region 620 may inhibit or prevent fluid leakage from a reservoir of an access port through the septum 610 when a pressure within the reservoir exceeds an ambient pressure external to the access port (e.g., during a power injection process, any process for flowing a fluid through an access port as described above, or any process for flowing a fluid through an access port as known in the art, without limitation). In addition, gel region 620 may be formulated and/or body 612 may be structured so that a cannula passing through septum 610 will resist transferring or removing any of the material comprising gel region 620 outside of a selected boundary or envelope. In one embodiment, body 612 may be structured to remove a material comprising gel region 620 from a cannula passing through the body 612.

[0146] Any of the septum embodiments discussed herein may include at least one gel region. For example, FIG. 55 shows a schematic, side cross-sectional view of a septum 611 including a body 612 and a gel region 620. As discussed above, gel region 620 may be structured so that a cannula

inserted through upper surface **614** and extending through lower surface **616** will pass through a portion of gel region **620**. Such a configuration may provide a robust septum that resists leaking even if a multitude of passages are formed through the septum with a cannula. Furthermore, providing a septum comprising a gel may improve a sealing ability or quality of the septum. Accordingly, a septum including a gel material may exhibit a reduced thickness (i.e., from an upper surface to a lower surface) in comparison to a conventional septum. For example, FIG. **56** shows a septum **613** including a body **612** and a gel region **620**, wherein a thickness T is less than a conventional thickness of a conventional septum. In one embodiment, a thickness T of septum **613** may be about 0.500 inches or less.

[0147] The instant disclosure contemplates a variety of different manufacturing methods may be employed for forming a septum comprising a gel. For example, generally, a body of a septum may be formed to substantially surround at least one gel region or a recess or chamber may be formed by a septum body that is filled with a gel. In one embodiment, a gel region may be suspended within a mold for forming a body of a septum. More particularly, FIG. **57** shows a schematic, side cross-sectional view of a first mold **652** and a second mold **654**, wherein gel region **620** is positioned between (e.g., suspended) first mold **652** and second mold **654**. As shown in FIG. **57**, gel region **620** is positioned by a frame element **630**, which abuts parting surface **655** of second mold **654**. As shown in FIG. **57**, frame element **630** may be positioned by pins **606**. In other embodiments, frame element **630** may be suitably positioned, without limitation. In a particular embodiment, parting surface **653** of first mold **652** may be positioned proximate to parting surface **655** of second mold **654** (i.e., parting surfaces **653** and **655** may be separated by frame element **630**) to form a chamber defined by cavity **658** and cavity **656**. Further, a hardenable material (e.g., a curable material, such as a curable silicone, a thermoplastic, a resin, etc.) may be injected into the chamber and hardened. Thus, the hardenable material may surround or encapsulate gel region **620** and may exhibit a geometry that is complimentary to cavities **656** and **658**.

[0148] Generally, frame element **630** may be coupled to or affixed to gel region **620**. In one embodiment, frame element **630** may couple or engage at least a portion of a periphery of gel region **620**. In another embodiment, frame element **630** may be substantially planar and gel region **620** may rest upon or may be formed upon frame element **630**. Further, in one embodiment, frame element **630** may extend at least partially through gel region **620**. Optionally, frame element **630** may cover or extend across mold cavity **656** of second mold **654**. In one example, frame element **630** may comprise a mesh (e.g., a metal or polymer mesh, a fabric, a fiber mesh, etc.). In another example, frame element **630** may comprise a sheet or layer of silicone and may be, optionally, perforated. If frame element **630** comprises a mesh or is perforated, fluid communication (of a hardenable material) between cavity **658** and cavity **656** may occur, which may be desirable for avoiding shifting of gel region **620** and/or frame element **630** during encapsulation. Once gel region **620** is encapsulated, selected portions of frame element **630** may be trimmed or cut, if desired.

[0149] In another method of forming a septum including at least one gel region, a septum body may be formed to include at least one chamber, which may be filled with a gel.

For example, FIG. **58** shows a septum body **612** defining chamber **621**. Optionally, opening **623** may be defined by body **612**. Accordingly, a gel may be introduced within chamber **621** via the opening **623** and the opening, optionally, may be closed. For example, an uncured gel may be introduced within chamber **621**. Further, the uncured gel may be cured by heating or by other suitable methods. Such a configuration may form a gel region as described above in relation to FIG. **55**. In one embodiment, chamber **621** may be formed by an air injection molding process, a blow molding process or any other process known in the art for creating a chamber **621** within body **612**. In another embodiment, body **612** may be formed about a removable plug or filler (e.g., a silicone plug, steel, or aluminum insert). Such a plug or filler may be coated with a nonstick coating (e.g., TEFLON®, silicone, or any nonstick coating known in the art). Thus, chamber **621** may be formed upon removal of the plug or filler. In other embodiments, portions of a septum may be formed, filled with a gel (or a liquid precursor to a gel), and bonded to one another to form a septum. In a further embodiment, body **612** may be initially formed and may enclose chamber **621** within body **612**. In addition, body **612** may be cut to form an opening to allow chamber **621** to be filled with a gel. Such an opening of body **612** may be closed or sealed to capture or form a gel region. In yet a further embodiment, a solid body may be formed and a chamber may be formed by slicing the solid body. In such a configuration, filling the chamber may cause the solid body to deform to form a domed or raised region, if desired. It will be appreciated that many different approaches may be employed for forming a chamber **621** within body **612** and subsequently filling the chamber with a gel.

[0150] In an additional embodiment, a septum may include a gel region positioned between a body and a layer of material bonded to or formed over at least a portion of the gel region and at least a portion of the body. For example, FIG. **59** shows a schematic, side cross-sectional view of a septum **615** including a body **632**, a gel region **620**, and a layer **626**. As shown in FIG. **59**, gel region **620** may be positioned within a recess **633** formed in the body **632** and layer **626** may extend over a portion of gel region **620** and a portion of body **632**. One of ordinary skill in the art will understand that gel region **620** may be positioned or formed within recess **633** of body **632** and then layer **626** may be formed or positioned over gel region **620** and body **632**. Further, layer **626** may be bonded (e.g., adhesively bonded, bonded via curing, bonded via welding, or as otherwise known in the art) or otherwise affixed to body **632** to capture gel region **620**. In one embodiment, septum **615** may be formed by a multiple head (e.g., a two head) injection molding apparatus. More particularly, such a molding apparatus may be capable of forming the body **632**, forming the gel region **620** within the body **632**, and forming (e.g., over molding) the layer **626** over the gel region **620** and body **632** by suitable mold configurations and material injections. Layer **626**, in one embodiment, may comprise a silicone-based material exhibiting a Shore A hardness of between about 60 and about 80. Body **632**, in one embodiment, may comprise a silicone-based material exhibiting a Shore A hardness of between about 40 and about 50. Accordingly, during use of septum **615** (installed within a housing to form an access port) a cannula may pass through layer **626**, at least a portion of gel region **620**, and body **632**. Such a

configuration may facilitate positioning of a cannula extending through layer 626, at least a portion of gel region 620, and body 632.

[0151] While certain representative embodiments and details have been shown for purposes of illustrating aspects of the instant disclosure, it will be apparent to those skilled in the art that various changes in the methods and apparatus disclosed herein may be made without departing from the scope of the instant disclosure, which is defined in the appended claims. For example, other access port sizes and shapes may be employed; and various other embodiments and structures may be employed for forming at least one identifiable feature of an access port of the instant disclosure. The words “including” and “having,” (including their variants) as used herein including the claims, shall have the same meaning as the word “comprising.”

What is claimed is:

1. A method of power injecting a contrast medium into a patient, comprising:

obtaining a power-injectable access port suitable for power injection, the power injectable access port comprising:

a housing defining a reservoir; and

a septum, comprising:

a self-sealing material; and

a radiopaque material forming a selected pattern when an x-ray is taken through the septum for identifying the power-injectable access port as being suitable for power injection, wherein:

the power-injectable access port is structured for accommodating a pressure developed within the reservoir of at least 35 psi, and

the power-injectable access port is designed to accommodate a fluid flow rate of at least 1 milliliter per second;

implanting the power-injectable access port in the patient;

imaging the power-injectable access port following the implanting;

confirming via the selected pattern in the septum that the power-injectable access port is suitable for injecting the contrast medium; and

injecting the contrast medium through the power-injectable port into the patient.

2. The method of power injecting according to claim 1, wherein the selected pattern in the septum includes one or

more letters, and wherein the confirming step comprises recognizing the one or more letters as indicating that the power-injectable access port is suitable for injecting the contrast medium.

3. The method of power injecting according to claim 1, wherein the injecting step comprises using an infusion set including a non-coring needle in fluid communication with a tubing, and a connector affixed to an outer surface of the tubing.

4. The method of power injecting according to claim 3, wherein each of the non-coring needle, the tubing, and the connector have a burst pressure of at least 100 psi.

5. The method of power injecting according to claim 3, wherein each of the non-coring needle, the tubing, and the connector have a burst pressure of at least 400 psi.

6. The method of power injecting according to claim 3, wherein each of the non-coring needle, the tubing, and the connector have a burst pressure of at least 600 psi.

7. The method of power injecting according to claim 3, wherein the injecting step comprises injecting the contrast medium through the infusion set at a rate of at least 5 milliliters per second.

8. The method of power injecting according to claim 1, wherein the imaging step comprises taking an x-ray of the power-injectable access port following the implanting.

9. The method of power injecting according to claim 1, further comprising, prior to the injecting step, verifying that the power-injectable access port is suitable for injecting the contrast medium by visually perceiving information outside of the patient on an element packaged with the power-injectable access port.

10. The method of power injecting according to claim 9, wherein the element is selected from the group consisting of a key chain, a bracelet, a wrist band, a sticker, a patient ID card, a label, and combinations thereof.

11. The method of power injecting according to claim 1, wherein the injecting step comprises injecting the contrast medium through the power-injectable access port at a rate of between 1 milliliter per second and 5 milliliters per second.

12. The method of power injecting according to claim 1, further comprising attaching a proximal end of a venous catheter to the power-injectable access port and guiding a distal end of the venous catheter through a vasculature of the patient to a target destination for the contrast medium.

* * * * *