



US 20170102099A1

(19) **United States**

(12) **Patent Application Publication**
Cripps, II

(10) **Pub. No.: US 2017/0102099 A1**

(43) **Pub. Date: Apr. 13, 2017**

(54) **MULTIPLE AXIS CONTROL SUSPENSION SYSTEM AND METHOD**

F16L 3/137 (2006.01)

F16L 3/26 (2006.01)

(71) Applicant: **Louis Cripps, II**, Caste Rock, CO (US)

(52) **U.S. Cl.**
CPC *F16L 3/221* (2013.01); *F16L 3/26* (2013.01); *F16L 3/18* (2013.01); *F16L 3/137* (2013.01)

(72) Inventor: **Louis Cripps, II**, Caste Rock, CO (US)

(21) Appl. No.: **15/384,814**

(22) Filed: **Dec. 20, 2016**

(57) **ABSTRACT**

Related U.S. Application Data

(62) Division of application No. 14/016,752, filed on Sep. 3, 2013, now Pat. No. 9,534,708.

(60) Provisional application No. 61/696,504, filed on Sep. 4, 2012.

Publication Classification

(51) **Int. Cl.**
F16L 3/22 (2006.01)
F16L 3/18 (2006.01)

A multiple axis control suspension system is disclosed. An example system includes at least one spine having a greater moment of inertia about a transverse centroidal axis than about a vertical centroidal axis. The example system includes at least one support member. A passage is formed through the at least one support member, the passage configured to receive the elongate spine. At least one receptacle is provided in the at least one support member, the at least one receptacle configured to receive at least one conduit such that a force acting on the conduit is transferred to the elongate spine.

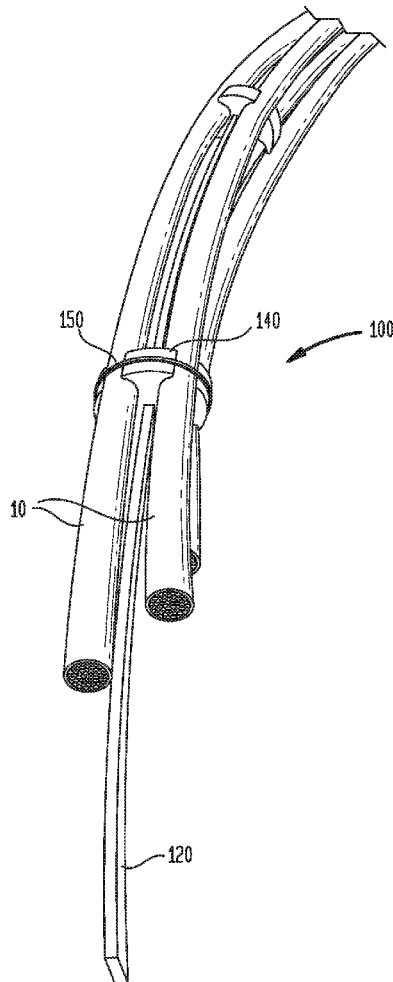
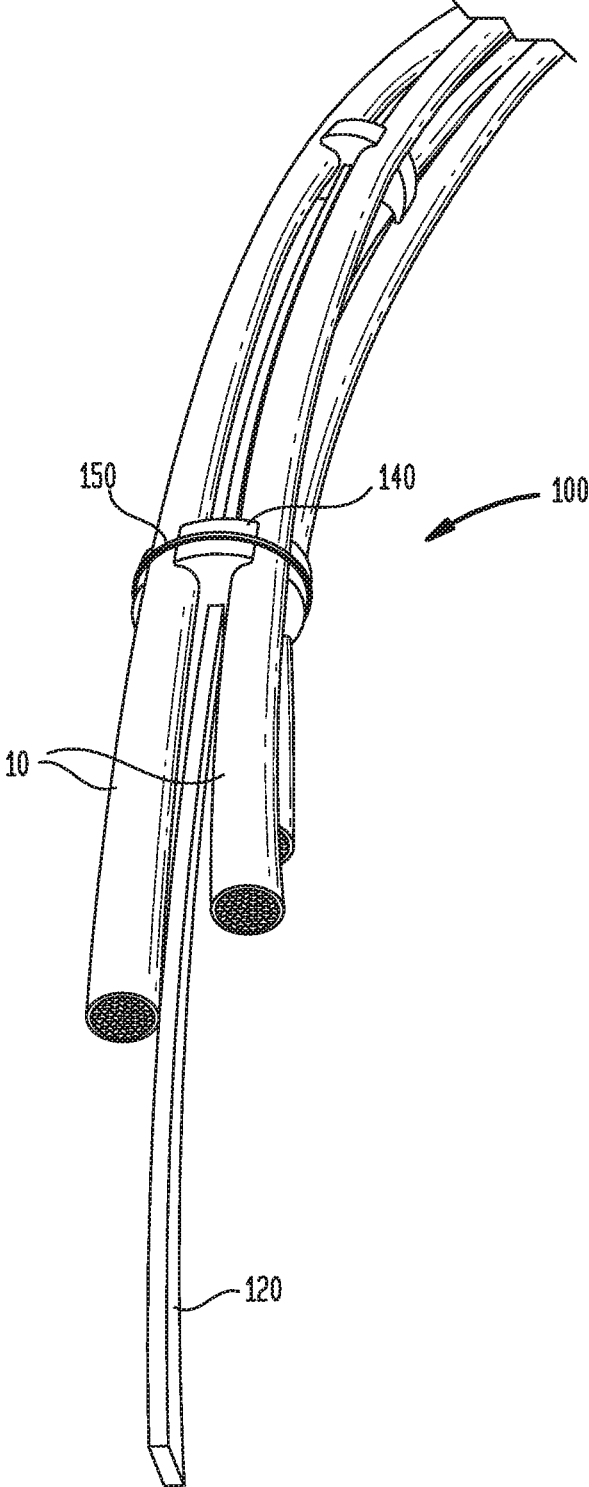

FIG. 1



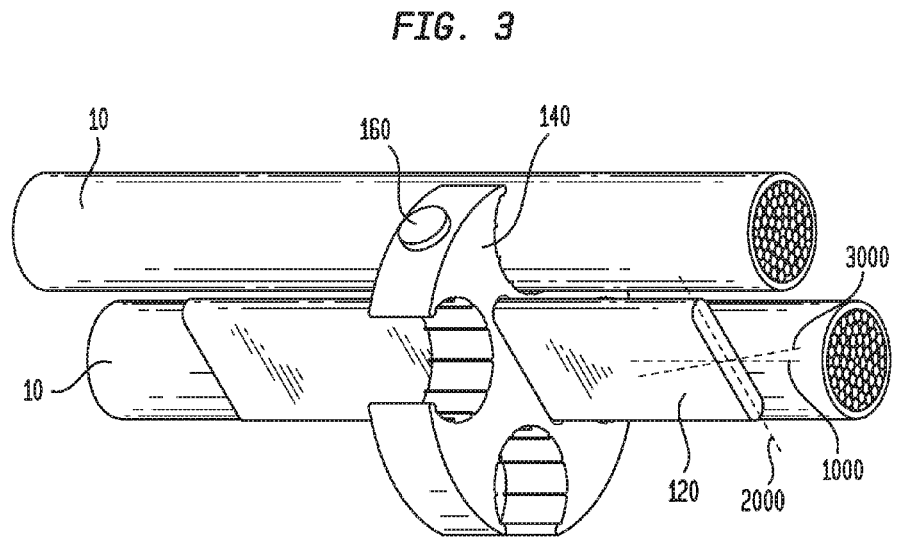
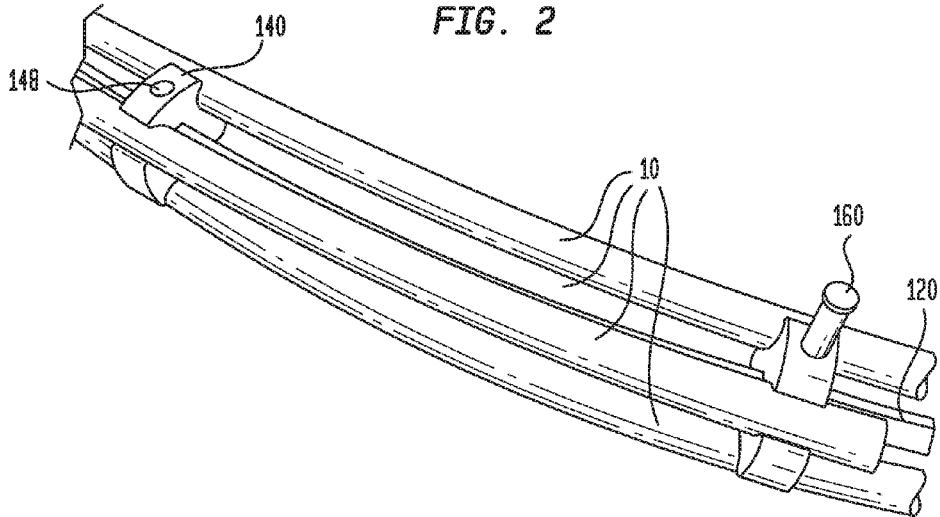

FIG. 4

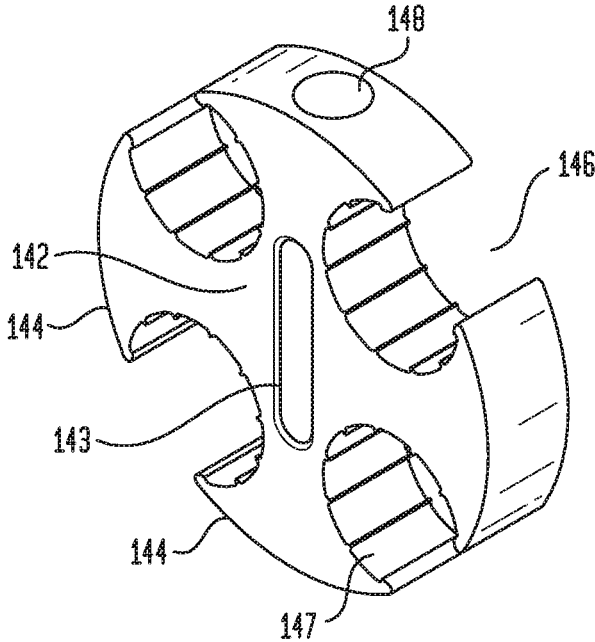

FIG. 5

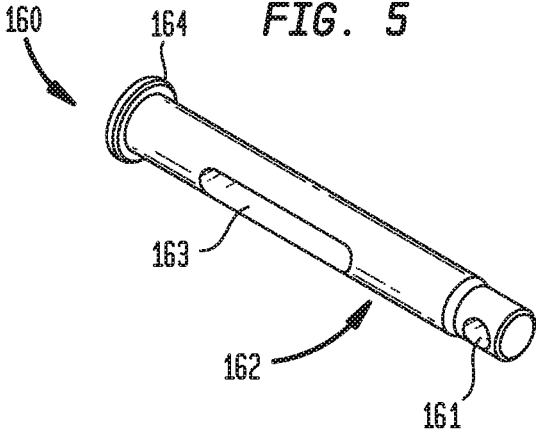

FIG. 6

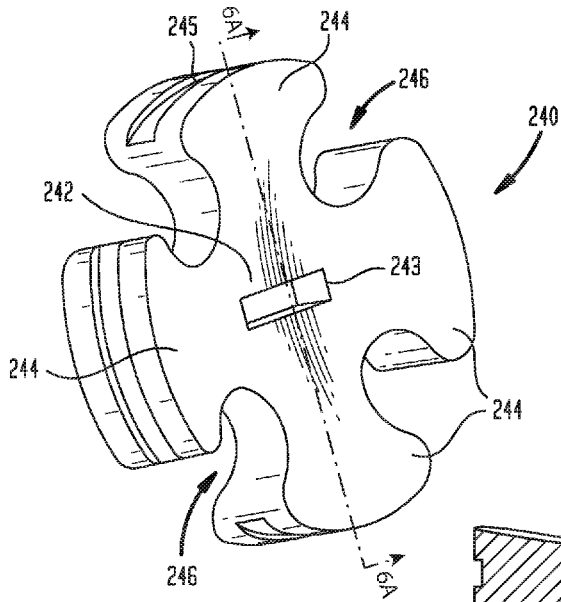

FIG. 6A

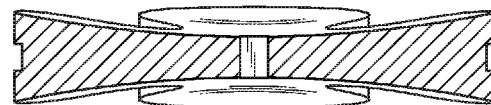

FIG. 7

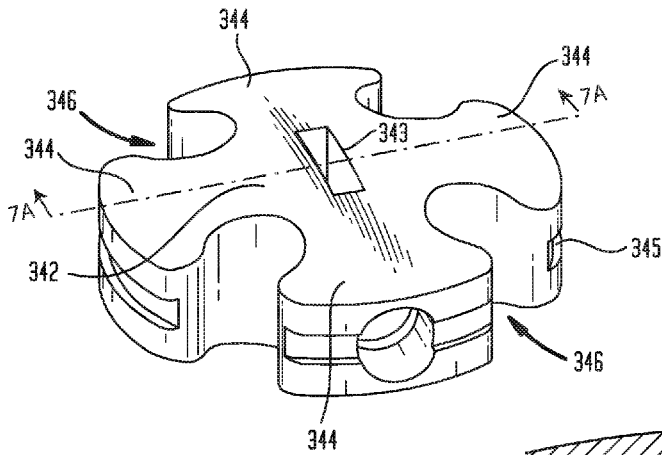
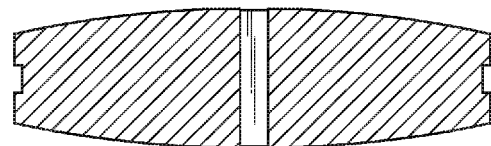

FIG. 7A



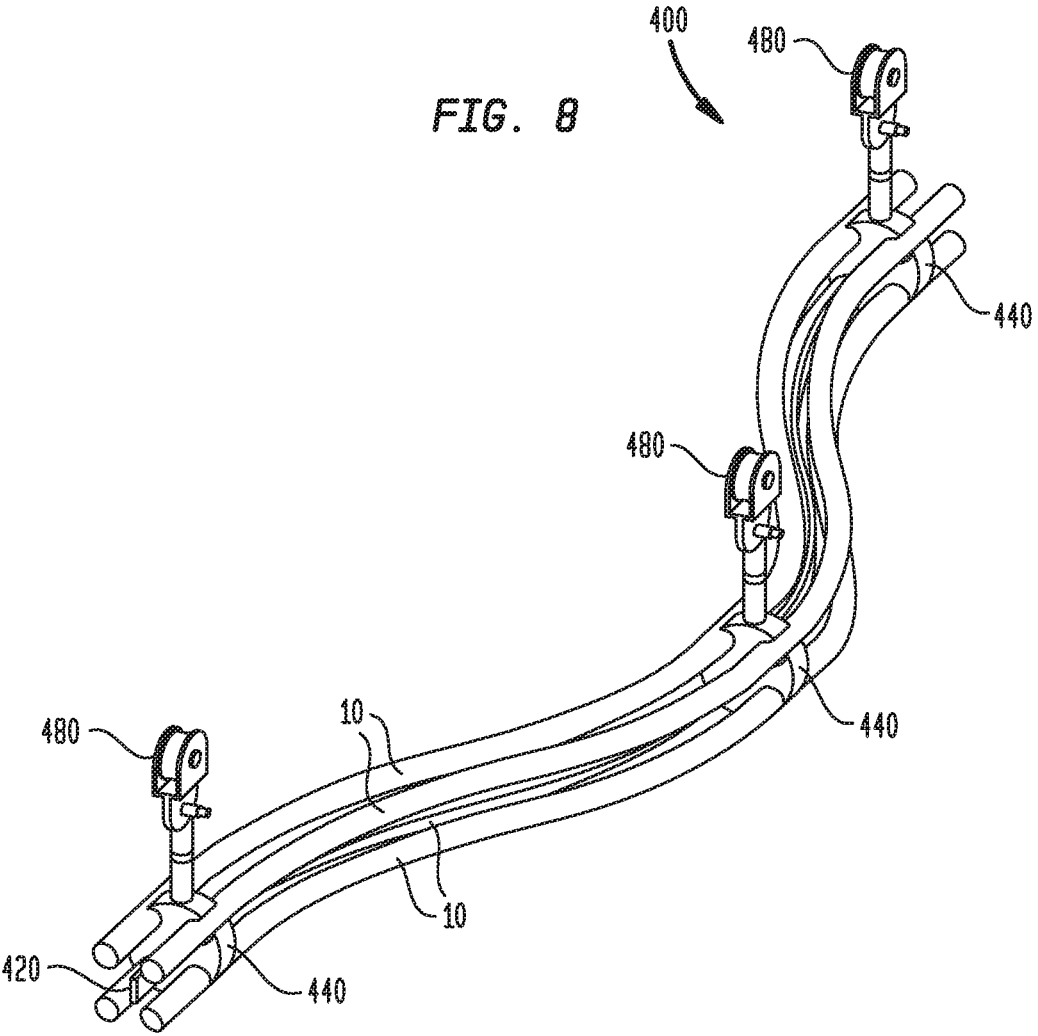

FIG. 9

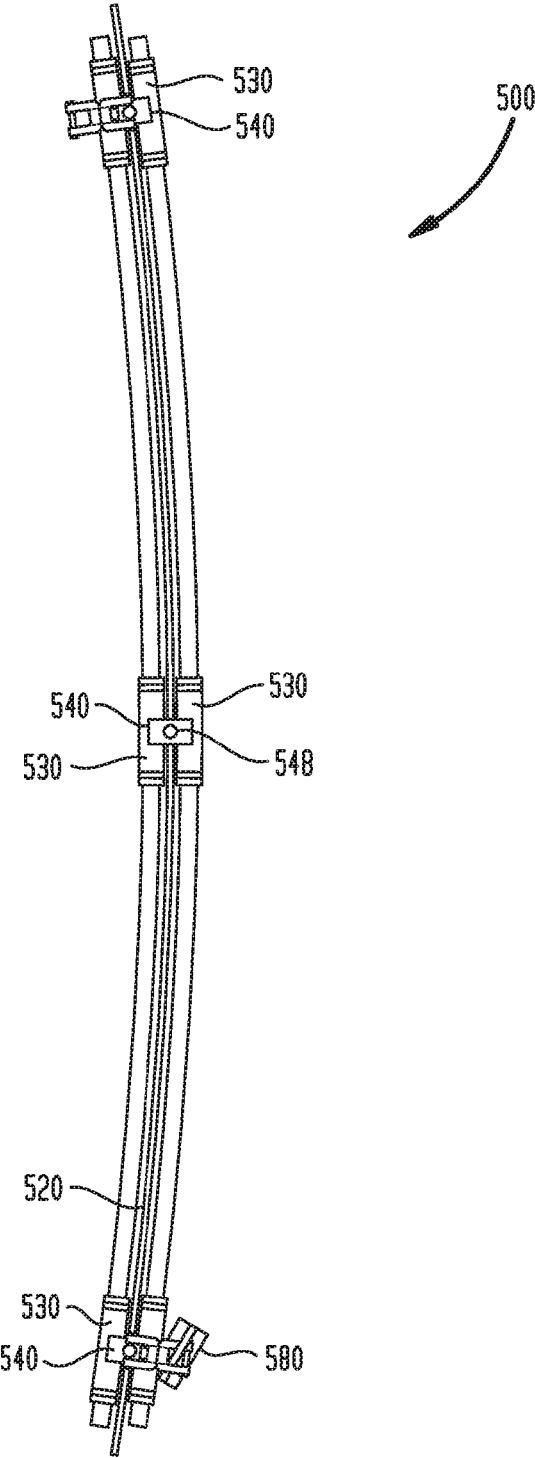

FIG. 9A

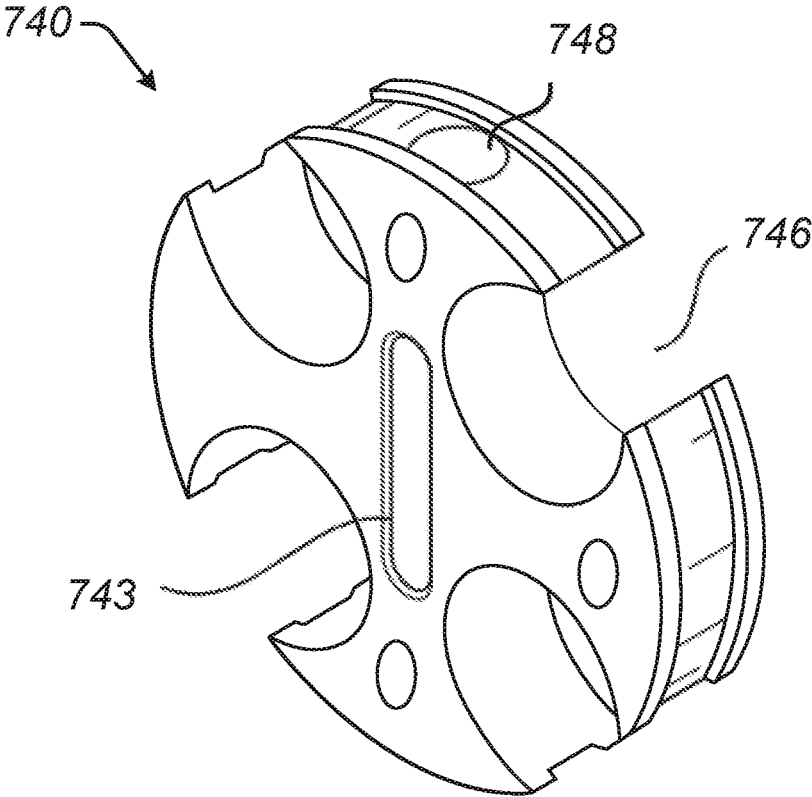

FIG. 10

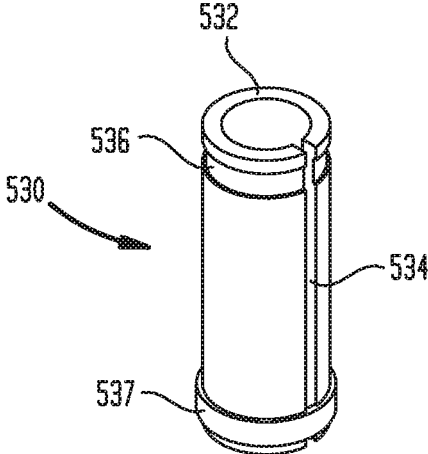

FIG. 11A

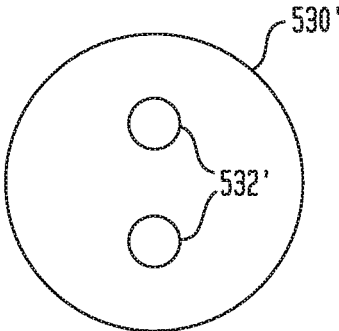

FIG. 11B

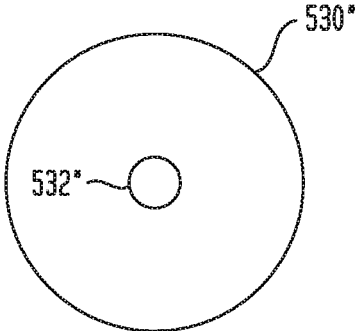

FIG. 12

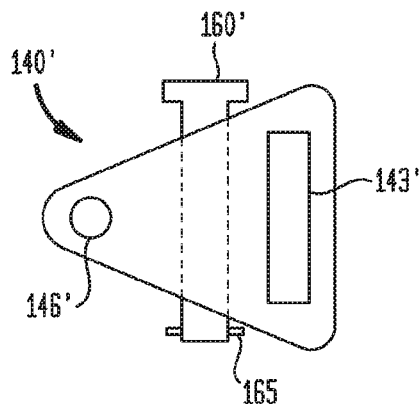

FIG. 13

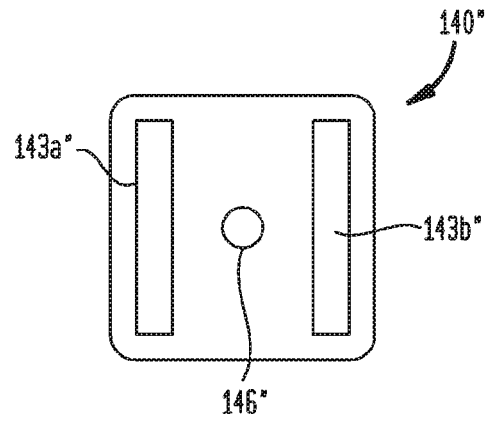

FIG. 14

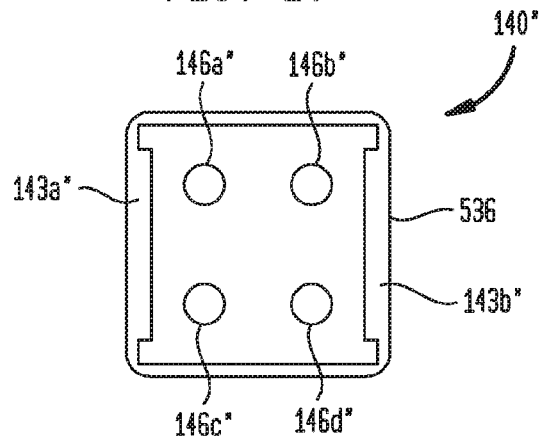

FIG. 15

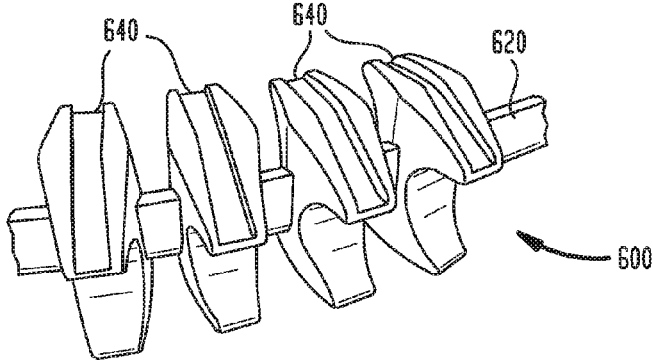

FIG. 16

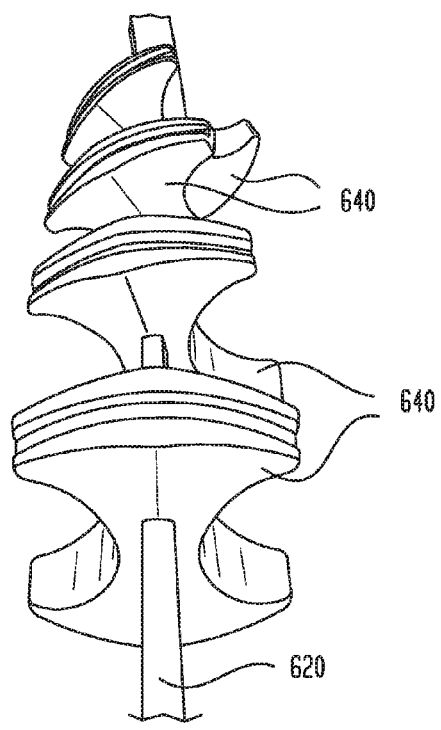
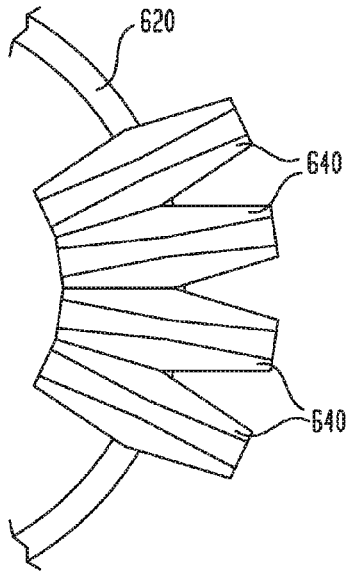

FIG. 17



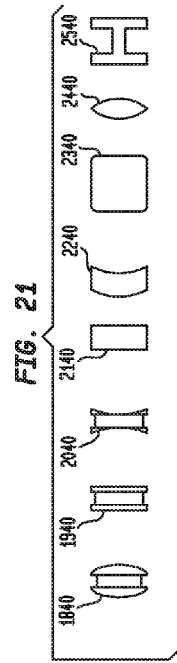
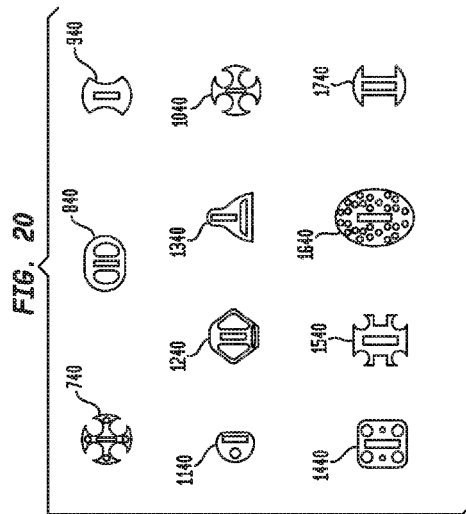
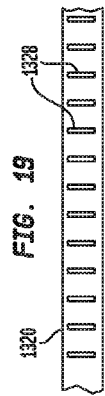
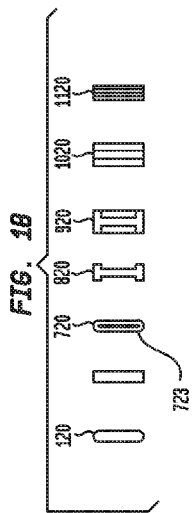

FIG. 22

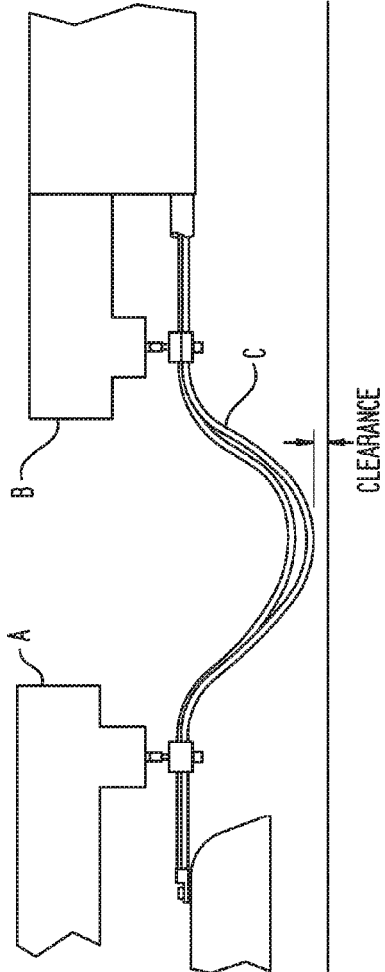
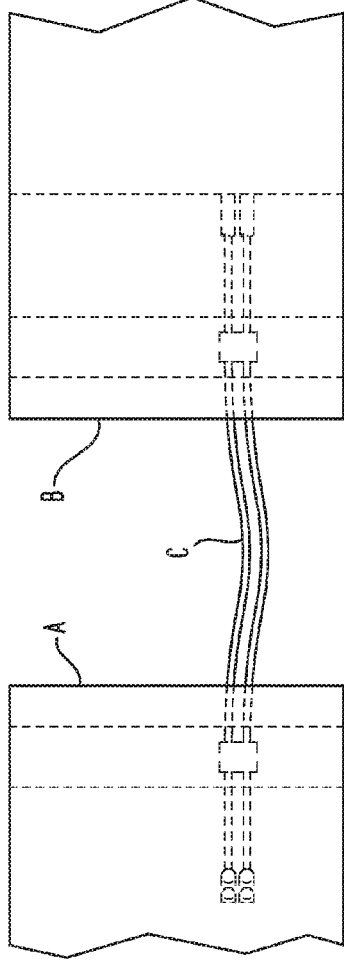
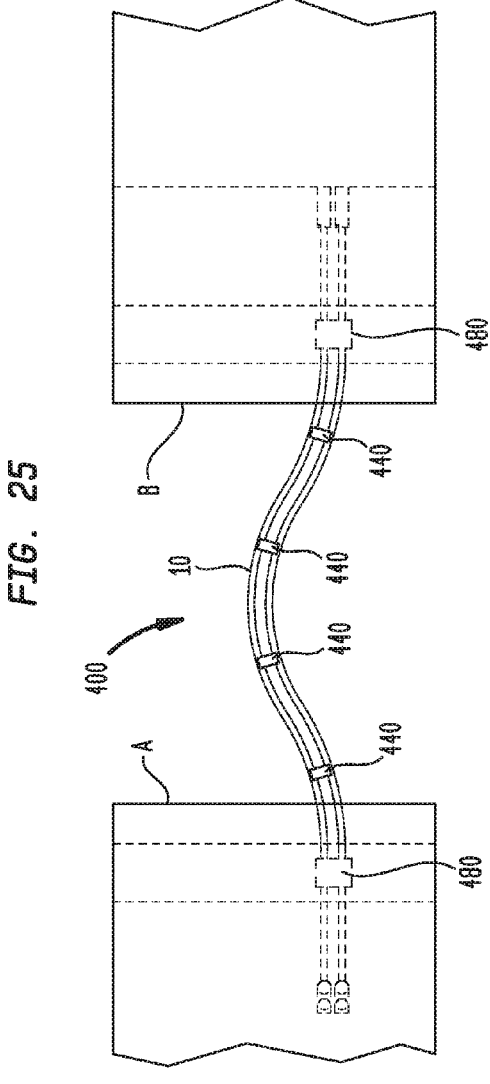
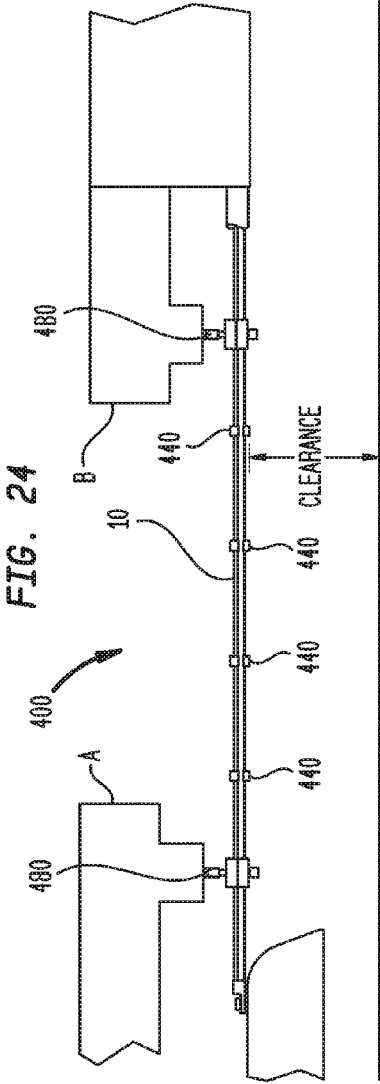

FIG. 23





MULTIPLE AXIS CONTROL SUSPENSION SYSTEM AND METHOD

PRIORITY CLAIM

[0001] This application is a divisional of U.S. patent application Ser. No. 14/016,752 filed on Sep. 3, 2013 titled “Multiple Axis Control Suspension System and Method” of Louis Cripps, which claims the priority filing date and benefit of U.S. Provisional Patent Application No. 61/696,504 filed on Sep. 4, 2012 titled “Multiple Axis Control Suspension System and Method” of Louis Cripps, each hereby incorporated by reference in its entirety as though fully set forth herein.

BACKGROUND

[0002] Conduits, such as wires, cables, and hoses are often connected between two locations or terminals. For example, a wire may be connected between a power source (e.g., an outlet) and a device that is being powered. Or for example, cables (e.g., fiber optic cables, computer cabling, and the like) may be connected between two or more devices or entities to provide a data connection. In another example, hoses may be connected between a source and a drain, container, or other destination for fluid carried in the hose.

[0003] In many applications, (e.g., electrical and hydraulic connection of train cars) the distance between two terminals may be subject to future increase, decrease or both. To provide for an increase in distance between two terminals, a length of conduit is used which is greater than the starting distance between the two terminals. This excess length may result in conduit slack.

[0004] Slack of electrical wiring may cause a short resulting in electrical hazards. Data flow over cables may be interrupted if the cables become damaged by undesired contact with the ground or other foreign surfaces. If slacking towards the ground, hoses can damage moving equipment parts. Preventing slacking, drooping or sagging of conduits reduces the potential for hazards and equipment damage but often results in reduced range of movement of the conduits.

BRIEF DESCRIPTION OF THE DRAWINGS

[0005] FIG. 1 illustrates a perspective view of an example multiple axis control suspension system.

[0006] FIG. 2 illustrates another perspective view of an example multiple axis control suspension system.

[0007] FIG. 3 illustrates a detail view of an example support member of an example multiple axis control suspension system.

[0008] FIG. 4 illustrates a perspective view of an example support member.

[0009] FIG. 5 illustrates a perspective view of an example pin of an example multiple axis control suspension system.

[0010] FIG. 6 illustrates a perspective view of another example support member of an example multiple axis control suspension system.

[0011] FIG. 6A illustrates a side cross sectional view of the example support member taken along lines 6-6 in FIG. 6.

[0012] FIG. 7 illustrates a perspective view of yet another example support member of an example multiple axis control suspension system.

[0013] FIG. 7A illustrates a side cross sectional view of the example support member taken along lines 7-7 in FIG. 7.

[0014] FIG. 8 illustrates a perspective view of another example multiple axis control suspension system.

[0015] FIG. 9 illustrates a top view of yet another example multiple axis control suspension system.

[0016] FIG. 9A illustrates a perspective view of an example support member.

[0017] FIG. 10 illustrates a perspective view of an example sleeve usable with an example multiple axis control suspension system.

[0018] FIGS. 11A-B illustrate other cross-sections for the example sleeve or bushing.

[0019] FIGS. 12-14 illustrate other plan views of the example support member.

[0020] FIG. 15 illustrates a perspective view of another example multiple axis control suspension system with support members in a spaced apart configuration.

[0021] FIG. 16 illustrates a top view of an example multiple axis control suspension system with support members in a spaced apart configuration.

[0022] FIG. 17 illustrates a front perspective view of an example multiple axis control suspension system with support members in a closed configuration.

[0023] FIG. 18 illustrates cross-sectional views of example spines.

[0024] FIG. 19 illustrates a side view of an example spine.

[0025] FIGS. 20-21 illustrate front views of example support members.

[0026] FIGS. 22-23 illustrate top and side views of a suspended cable.

[0027] FIGS. 24-25 illustrate top and side views of a suspended cable using a multiple axis control suspension system.

DETAILED DESCRIPTION

[0028] Multiple axis control suspension systems and methods of using the same are disclosed. In an example, a system includes a plurality of support members and at least one spine configured to receive the support members. The system may be used to change the direction of slack, for example, in applications where high-flex cables, wires or hoses are connected between two moving parts. Thus, undesired contact of these conduits with foreign objects may be reduced or altogether prevented.

[0029] A multiple axis control suspension system allows for freedom of movement along one axis, while restricting movement in a different direction to provide support and strength. When slack is displaced outside of the vertical plane, for example, into the horizontal plane, additional length of wire, cable or hose can be provided as-needed for connection of fixed-to-fixed, fixed-to-moving, and/or moving-to-moving components. With slack displaced outside of the vertical plane, additional length does not sag or droop under the force of gravity. Thus, conduits may be kept out of harm’s way.

[0030] Before continuing, it is noted that as used herein, the terms “includes” and “including” mean, but is not limited to, “includes” or “including” and “includes at least” or “including at least.” The term “based on” means “based on” and “based at least in part on.”

[0031] FIGS. 1-3 illustrate an example multiple axis control suspension system 100. The multiple axis control suspension system 100 may include an elongate spline or spine 120, and a plurality of support members 140.

[0032] Elongate spine **120** may provide greater flexibility about a vertical centroidal axis **2000** than about transverse **3000** and longitudinal **1000** centroidal axes. For example, elongate spine **120** may have a greater moment of inertia about transverse centroidal axis **3000** than about vertical centroidal axis **2000** or longitudinal centroidal axis **1000**. As such, the elongate spline **120** resists a greater bending moment about the transverse centroidal axis **3000** than about the vertical centroidal axis **2000**.

[0033] It is noted that the maximum or yield bending moment of system **100** can be varied by spine material variation and flexibility of spine **120** can be adjusted by varying support member frequency.

[0034] Support members **140** (see e.g., FIGS. 3-4) may be configured to receive elongate spine **120** through passages **143**. Passages **143** may take any of a variety of cross-sectional shapes including but not limited to rectangular. In addition, passages **143** may be central and/or offset in the support members **140**. Each support member **140** includes a plurality of receptacles **146** configured to receive wires, cables, hoses or other similar conduits **10** such that a downward-acting force on conduits **10** is transferred through the support members **140** to the elongate spine **120**. Receptacles **146** open toward an exterior and may include a plurality of teeth or other friction modifying (e.g., friction reduction) members **147**.

[0035] Support members **140** include a transverse through-bore **148** configured to receive a pin **160**. With reference to FIG. 5, pin **160** comprises a head **164** and a shaft **162** including two transverse through-bores **161** and **163**. Through-bore **163** may be elongate and configured to receive the spine as a through-slot. Through-bore **161** may be circular and configured to receive a cotter pin or the like to hold pin **160** in place.

[0036] It should be noted that some support members **140** may be provided without a transverse through-bore. Support members **140** may be discs with a roughly circular perimeter. However, any of a variety of shapes may be advantageously used. By way of further illustration, see FIGS. 15-17 and 20-21.

[0037] A constraining band **150** (FIG. 1) may be configured to surround the perimeter of one of the support members **140** to hold conduits **10** within open receptacles **146**. In some example systems, constraining band **150** is configured to be received by circumferential grooves provided in support members **140**.

[0038] In an example, support members may be constructed to have cooperating faces. With reference to FIGS. 6 & 7, female support members **240** are shown having a concave exterior surface **242** with negative curvature and male support members (see, e.g., FIG. 7) have a convex exterior surface **342** with positive curvature. Given similar radii of curvature, surfaces **242** are configured to mate with surfaces **342**. The perimeter of support members **240** and **340** may take any of a variety of shapes including but not limited to roughly circular.

[0039] In an example, receptacles **246** and **346** open towards an exterior of the support members **240** and **340** and are configured to hold and support conduits **10**. Passages **243** and **343** may take any of a variety of cross-sectional shapes including but not limited to rectangular. Circumferential grooves **245** and **345** are provided to accommodate, for example, a tie, clamp, band (or other mechanism) such as

band **150**. A transverse through-bore in support members **340** is configured to receive a pin such as pin **160**.

[0040] FIG. 8 illustrates a perspective view of an example multiple axis control suspension system **400** including an elongate spline or spine **420**, a plurality of support members **440** and a number of hangers **480** configured for coupling with selected support members to suspend system **400** from a support surface. It is noted that although hangers **480** are shown on each support member **440**, hangers **480** do not need to be provided on each support member.

[0041] Support members **440** may include receptacles which open toward an exterior and are configured to hold and support conduits **10**. Passages may be configured to receive the spine **420**, and may take any of a variety of cross-sectional shapes including but not limited to rectangular. A transverse through-bore may be provided in support members **440** to receive a pin for facilitated coupling of hangers or supports **480** thereto.

[0042] FIG. 9 illustrates a top view of an example multiple axis control suspension system **500**. Support members **540** are shown including receptacles which open towards an exterior and are configured to hold and support sleeves **530** and conduits **10**. Passages configured to receive spine **520** may take any of a variety of cross-sectional shapes including but not limited to rectangular. It is also noted that the conduits **10** may be supported at the spine **120**, at the support members **140**, or at least partially at both.

[0043] FIG. 9A illustrates a perspective view of an example support member **740**. In FIG. 9A, 700-series number refer to like components already described above for 100-series numbers, and therefore description may not be repeated for FIG. 9A. Support members **740** may be configured to receive elongate spine **120** through passage **743**. Passage **743** may be central in the support members **740**. Each support member **740** includes a plurality of receptacles **746** configured to receive wires, cables, hoses or other similar conduits **10** such that a downward-acting force on conduits **10** is transferred through the support members **740** to the elongate spine **120**. Receptacles **746** open toward an exterior. Support members **740** include a transverse through-bore **748** configured to receive a pin **160** (FIG. 5).

[0044] A hanger **580** may be used to suspend the system **500** away from an adjacent surface (e.g., away from a floor, ceiling, and/or wall). In an example, the hangers **580** connect to the pin **160** and thus feed through the support member and around the spine via notch **163** (see, e.g., FIGS. 4-5). In another example, the hangers may attach directly to the spine and provide support via the spine. In another example, hangers may be attached to the spine and/or support members. It is noted that the system **100** may be supported from above (e.g., by hanging), from below (e.g., by the system **10** resting on a support or base), or at least partially from above and at least partially from below. The hanger **580** may also be implemented with stand-offs (e.g., the hanger for spacing the conduit from a ceiling and the stand-off for spacing the conduit from a side wall). The hangers **580**, base, and/or stand-offs themselves are not limited to any particular configuration.

[0045] One or more bushing or sleeves **530** may be received in the receptacle(s) formed in the support members **540**. In an example, sleeves **530** are shown in FIG. 10 each including a lumen **532** (e.g., a central lumen) and a longitudinal split **534** which opens the lumen **532** to a side. Sleeves **530** may assist in reducing wear on the conduit

shielding or insulation. As described above, the longitudinal split allows for adjusting the cross section of the lumen. Sleeves **530** are configured to hold and support conduits **10** and may include an annular groove **536** configured to receive a compression band **537**, clamp or other enclosure mechanism.

[0046] FIGS. **11A-B** illustrate other cross-sections for the example sleeve or bushing (e.g., bushing **530** shown in FIG. **10**). In an example shown in FIG. **11B**, the bushing **530'** may have a plurality of lumens **532'** for receiving multiple conduits and maintaining the conduits in a fixed, spaced-apart relation to one another. In another example shown in FIG. **11B**, the bushing **530"** may include different size inner diameters of the lumen **532"** to support different diameter conduit. Accordingly, the same support member may be used for different size and/or number of conduit by simply using a different bushing. Indeed, different bushings may be used in separate receptacles of the same support member. Other configurations are also contemplated.

[0047] FIGS. **12-14** illustrate other plan views of the example support member (e.g., support member **140** in FIG. **4**). These examples are provided by way of illustration. Other configurations are also contemplated.

[0048] In FIG. **12**, the support member **140'** is shown wherein the pin **160'** for the hanger is between the receptacle **146'** and the opening **143'** for the spine. In this example, the pin **160'** does not need opening **163** as shown in FIG. **5**. FIG. **12** also illustrates pin **160'** held in support member **140'** by a cotter pin **165** (although other means for securing the pin **160'** are contemplated).

[0049] In FIG. **13**, the support member **140"** is shown wherein the receptacle **146"** is substantially central to the support member **140"**, and a plurality of openings **143a-b"** (only two are illustrated, but more are possible) are provided for multiple spines.

[0050] In FIG. **14**, the support member **140"** is shown wherein a plurality of receptacles **146a-d"** provided along with a plurality of openings **143a-b"** (only two are illustrated, but more are possible) are provided on an outer perimeter for multiple spines. In this example, a band **536** may be provided to secure the spines to the support member **140"**.

[0051] FIGS. **15-17** illustrate an example multiple axis control suspension system **600**. In FIGS. **15-16**, support members **640** are shown in a spaced apart configuration on spine **620**. In FIG. **17**, the support members **640** are shown in a close configuration. With support members **640** in a spaced apart relation, the flexibility of spine **620** is relatively high (e.g., as compared with the closely spaced relation shown in FIG. **17**).

[0052] Support members **640** may include receptacles opening towards an exterior and configured to receive and support conduits **10**. Circumferential grooves may be provided in support members **640**, and are formed to receive a constraining band such as band **150** which is capable of surrounding the perimeter of one of the support members **640** to hold conduits **10** thereto. Support members **640** may also include a perimeter having circular arc inferior and superior portions. However, any of a variety of shapes may be advantageously used. For purposes of further illustration, see the examples in FIGS. **15-17** and **20-21**.

[0053] FIG. **18** illustrates cross-sectional views of a variety of different example spines. Spine **120** is shown having a rectangular cross section. Spine **720** is shown having an

elliptical cross section and a longitudinal opening or lumen **723**. Spine **820** is shown having an I-shape cross section. Spine **920** is shown having an alternate cross section. Spine **1020** is shown having a parallel cross-section. Spine **1120** is shown having an alternate parallel cross-section. Still other configurations are also contemplated.

[0054] Spine flexibility can be increased or decreased, for example, by machining patterns into the parallel sides. FIG. **19** illustrates a side view of an example spine **1320** having a plurality of spaced, transverse through-bores **1328** which may be provided to spine **1320** in any of a variety of shapes, sizes and frequencies. Still other configurations are also contemplated.

[0055] FIG. **20** illustrates front views of a variety of example support members. Support members **740**, **940** and **1040** may have a roughly circular perimeter. Support members **840**, **1640** and **1740** may have a roughly oval perimeter. Support members **1140** and **1340** may have a roughly triangular perimeter. Support members **1440** and **1540** may have a roughly rectangular perimeter. Support members **1240** may have a roughly hexagonal perimeter. Support members **940**, **1040**, **1540** and **1740** include receptacles open to the exterior of their circumferences, while support members **840**, **1140**, **1240**, **1340**, **1440** and **1640** include closed receptacles. Support members **740** have both open and closed receptacles. Still other configurations are also contemplated.

[0056] In an example, some support members may include more than one passage configured to receive a spine. For example, a first passage may have a rectangular shape oriented in a first direction, and a second passage may have a rectangular cross section rotated 90 degrees with respect to the first passage.

[0057] FIG. **21** illustrates side or profile views of a variety of different example support members. Support members **1840** are shown having first and second exterior faces with convex profiles. Support members **1940**, **2140** and **2340** are shown having first and second exterior faces with flat or straight profiles. Support member **2040** is shown having first and second exterior faces with concave profiles. Support members **2240** and **2440** are shown having a first exterior face with a convex profile and a second exterior face with a concave profile. Support member **2540** is shown having a substantially H-shape. Still other configurations are also contemplated.

[0058] FIGS. **22-23** illustrate top and side views of a suspended cable. FIG. **22** illustrates a side view and FIG. **23** illustrates a top view showing a conduit suspended between terminals A and B. In an example where the distance between terminal A and terminal B may increase, a length of conduit C is provided which is greater than the starting distance between A and B. In many circumstances, the length of conduit C will be greater than the expected increased distance between terminals A and B (e.g., determined by a factor of safety (FOS)). Due to the extra length of conduit C provided, conduit C may slack toward the ground when the distance between terminals A and B is small as shown in FIG. **22**, and remains within a vertical plane as shown in FIG. **23**.

[0059] FIGS. **24-25** illustrate top and side views of a suspended cable using a multiple axis control suspension system **400**. FIG. **24** illustrates a side view and FIG. **25** illustrates a top view of a conduit system. In this illustration, the distance between terminal A and terminal B may change

(shorten and/or lengthen), a length of conduit **10** may be provided which is greater than the starting distance between A and B. It can be seen that provision of multiple axis and control suspension system **400** maintains a large clearance between conduit **10** and foreign objects or surfaces beneath conduit **10**, as shown in FIG. **24**, by converting downward slack in conduit **10** into a horizontal plane as shown in FIG. **25**.

[0060] Before continuing, it should be noted that the examples described above are provided for purposes of illustration, and are not intended to be limiting. Other devices and/or device configurations may be utilized to implement the system and method described herein. Still other examples are also contemplated.

[0061] By way of illustration, support members may be formed from any of a variety of relatively rigid, durable materials including but not limited to metals, rubbers, plastics, composite materials, or woods. Spines may be formed from any of a variety of durable materials which may demonstrate a single flexibility in all directions or different flexibilities in different directions.

[0062] It is also noted that components of an example multiple axis control suspension system may be interchanged with components of another example multiple axis control suspension system in a modular design, thereby allowing for scaling in size, application, or both. The open design of system also allows debris to fall through the cabling, enabling use in harsh or outdoor environments.

[0063] A method of supporting a conduit using a multiple axis control suspension system (e.g., system **100** shown and described herein) is also disclosed. In an example method, a conduit (e.g., a wire, cable, or hose) may be supported using the system to change an orientation of a flexible spine, thus allowing control over range of motion and variability of terminal distance without droop or sag. Free spanning gaps of wires, cables, or hoses or other conduits may be separated and deflected to allow freedom of movement.

[0064] In an example, a plurality of support members (e.g., support members **140**) are provided including at least one passage for at least one spine, and receptacles configured to hold and support one or more conduit, while still enabling motion of the conduit relative to the support members. The spine is arranged through a passage of the support members. One or more conduits may then be positioned in the receptacles of the plurality of support members. Exterior surfaces of the conduit may be held by bushings and/or teeth (and/or other friction reduction members) formed in the receptacles of the support members. The bushings and teeth may serve to reduce friction between the conduit and the support member and reduce wear.

[0065] If sleeves or bushings are being used, the conduits may be inserted into lumens of the sleeves. Upon insertion of conduits into the sleeves, exterior surfaces of the conduit may be held more firmly by decreasing the gap size of a longitudinal split in the sleeves, wrapping constraining bands around the sleeves, or both. Constraining bands may engage with annular grooves of the sleeves. The sleeves with conduit may be inserted into receptacles of the support members.

[0066] The user can install the conduits into the receptacles of the support member, or feed these through a closed hole in the support member. Then the spine can be fed through the support members to allow some or all of the weight of the conduits to be supported by the spine and

hangers. Through-style supports are also provided, wherein the spine can be rotated. Spine rotation with the clamp style support can be achieved by using the through-holes in the support members.

[0067] With conduits in the receptacles, the conduits are movably constrained thereto. Bands or ties may be used for additional security. In an example, bands may be provided in circumferential grooves on the support members.

[0068] Supports may be provided to suspend the conduits. In an example, hangers are coupled to pins in the one or more of the support members. The spine, in addition to being arranged through the passages in the support members, may also be arranged through transverse bores of the pins. The conduits may be suspended from the top, side(s), and/or bottom by attaching to one or more of the support members and/or the spine.

[0069] In an example, spacers may be provided between the support members to increase flexibility in a side-to-side range of motion. In another example, spacers can be pinned along the spine to limit side-to-side motion. Additional support members can be added, and the free space can be used to limit movement.

[0070] During use, the flat parallel sided spine feeds through the support members. Because the spine is made of a flexible material, freedom of motion is provided in one axis (e.g., side-to-side), while strength and support is provided in another axis (e.g., up-down direction), thus allowing the user to free-span long gaps without droop or sag. The user can change the direction of axis of control by changing the attaching point of the support member (e.g., by rotating the spine 90 degrees).

[0071] Still other examples are also contemplated as being within the scope of the disclosure, as will become readily apparent to those having ordinary skill in the art after becoming familiar with the teachings herein.

1. A multiple axis control suspension apparatus, comprising:

- a elongate spine configured to resist a greater bending moment about a transverse centroidal axis of the elongate spine than about a longitudinal centroidal axis of the elongate spine, and the elongate spine having a substantially rectangular shaped cross section;
- a support member having a passage and at least one through-bore substantially perpendicular to the longitudinal centroidal axis of the elongate spine, the passage having a generally rectangular shaped cross section and extending through the support member to receive the elongate spine so that the elongate spine and the support member are movable relative to one another along the longitudinal centroidal axis of the elongate spine, the at least one through-bore extending completely through the support member, the support member having at least one generally circular shaped opening formed therein to hold at least one conduit, and the support member configured to transfer a force acting on the at least one conduit held by the support member to the elongate spine; and
- a shaft received in the at least one through-bore of the support member, the shaft having a generally cylindrical portion extending substantially perpendicular to the longitudinal centroidal axis of the elongate spine, the generally cylindrical portion having a generally rectangular shaped opening formed therethrough, and the elongate spine received in the generally rectangular

shaped opening and extending continuously into the generally rectangular shaped opening at a first open distal end of the generally rectangular shaped opening, laterally through the generally rectangular shaped opening, and out of the generally rectangular shaped opening at a second open distal end of the generally rectangular shaped opening.

2. The multiple axis control suspension apparatus of claim 1, further comprising a conduit sleeve extending through the support member.

3. The multiple axis control suspension apparatus of claim 2, wherein the conduit sleeve has a central lumen and a longitudinal split to adjust a cross section of the central lumen for various sizes of the at least one conduit.

4. The multiple axis control suspension apparatus of claim 1, wherein the support member is generally square shaped.

5. The multiple axis control suspension apparatus of claim 1, wherein the support member is generally semi-circular shaped.

6. The multiple axis control suspension apparatus of claim 1, wherein the support member is generally triangular shaped.

7. The multiple axis control suspension apparatus of claim 1, further comprising a constraining band configured to surround a perimeter of the support member and the at least one conduit.

8. The multiple axis control suspension apparatus of claim 1, wherein the support member is configured to receive a plurality of conduits and a plurality of spines.

9. A multiple axis control suspension system, comprising: an elongate spine having a greater moment of inertia about a transverse centroidal axis of the elongate spine than about a longitudinal centroidal axis of the elongate spine, and the elongate spine having a substantially rectangular shaped cross section;

at least one support member having a passage and at least one through-bore substantially perpendicular to the longitudinal centroidal axis of the elongate spine, the passage having a substantially rectangular shaped cross section and formed through the at least one support member to receive the elongate spine so that the elongate spine and the at least one support member are movable relative to one another along the longitudinal centroidal axis of the elongate spine, the at least one through-bore extending completely through the at least one support member, and the at least one support member having at least one substantially circular shaped receptacle formed therein to receive at least one conduit and allow a force acting on the at least one conduit to be transferred to the elongate spine; and

a shaft received in the at least one through-bore of the at least one support member, the shaft having a substantially rectangular shaped opening formed therethrough, the shaft having a substantially cylindrical portion

extending substantially perpendicular to the longitudinal centroidal axis of the elongate spine, the substantially cylindrical portion having a transverse bore formed therethrough, and the elongate spine received in the substantially rectangular shaped opening and extending continuously into the substantially rectangular shaped opening at a first open distal end of the substantially rectangular shaped opening, laterally through the substantially rectangular shaped opening, and out of the substantially rectangular shaped opening at a second open distal end of the substantially rectangular shaped opening.

10. The multiple axis control suspension system of claim 9, wherein the at least one substantially circular shaped receptacle is open toward an exterior perimeter of the at least one support member.

11. The multiple axis control suspension system of claim 9, wherein the at least one substantially circular shaped receptacle has a plurality of friction-reduction teeth.

12. The multiple axis control suspension system of claim 9, wherein the at least one support member has at least one female member having concave exterior faces, or wherein the at least one support member has at least one male member having convex exterior faces.

13. The multiple axis control suspension system of claim 9, further comprising a band wrapped around a perimeter groove of the at least one support member.

14. The multiple axis control suspension system of claim 9, further comprising a bushing having an outer diameter configured to fit within the at least one substantially circular shaped receptacle and an inner diameter configured to receive the at least one conduit.

15. The multiple axis control suspension system of claim 9, further comprising a bushing configured to receive a plurality of conduits extending through the at least one substantially circular shaped receptacle.

16. The multiple axis control suspension system of claim 15, wherein the bushing is configured to retain the plurality of conduits in a fixed, spaced apart relationship with respect to one another.

17. The multiple axis control suspension apparatus of claim 9, wherein the support member is generally non-circular shaped.

18. The multiple axis control suspension apparatus of claim 9, wherein the support member is generally triangular shaped.

19. The multiple axis control suspension apparatus of claim 9, wherein the support member is generally square shaped.

20. The multiple axis control suspension apparatus of claim 9, wherein the support member is generally semi-circular shaped.

* * * * *