



US 20170209263A1

(19) **United States**

(12) **Patent Application Publication**
Munnely et al.

(10) **Pub. No.: US 2017/0209263 A1**

(43) **Pub. Date: Jul. 27, 2017**

(54) **METHOD AND APPARATUS FOR PREPARING A CONTOURED BIOLOGICAL TISSUE**

Publication Classification

(51) **Int. Cl.**
A61F 2/24 (2006.01)
(52) **U.S. Cl.**
CPC *A61F 2/2415* (2013.01); *A61F 2/2412* (2013.01); *A61F 2240/004* (2013.01)

(71) Applicant: **Edwards Lifesciences Corporation**, Irvine, CA (US)

(72) Inventors: **Amy E. Munnely**, Irvine, CA (US);
Jeffrey S. Dove, Santa Ana, CA (US);
Minsey Lee, Irvine, CA (US)

(57) **ABSTRACT**

An assembly and methods for providing a contoured biological tissue are described. The assembly comprises a first plate and a second plate. The first plate is configured to receive a biological tissue. The second plate is configured to contact and compress the biological tissue received on the first plate. One or both of the first and second plates comprise a defined shape and a contoured area within the defined shape. The contoured area comprises at least first and second elevations. One or more energy sources are associated with one or both of the first and second plates. The one or more energy sources deliver energy upon compression of the biological tissue.

(21) Appl. No.: **15/483,786**

(22) Filed: **Apr. 10, 2017**

Related U.S. Application Data

(63) Continuation of application No. 14/485,576, filed on Sep. 12, 2014, now Pat. No. 9,615,922.

(60) Provisional application No. 61/884,775, filed on Sep. 30, 2013.

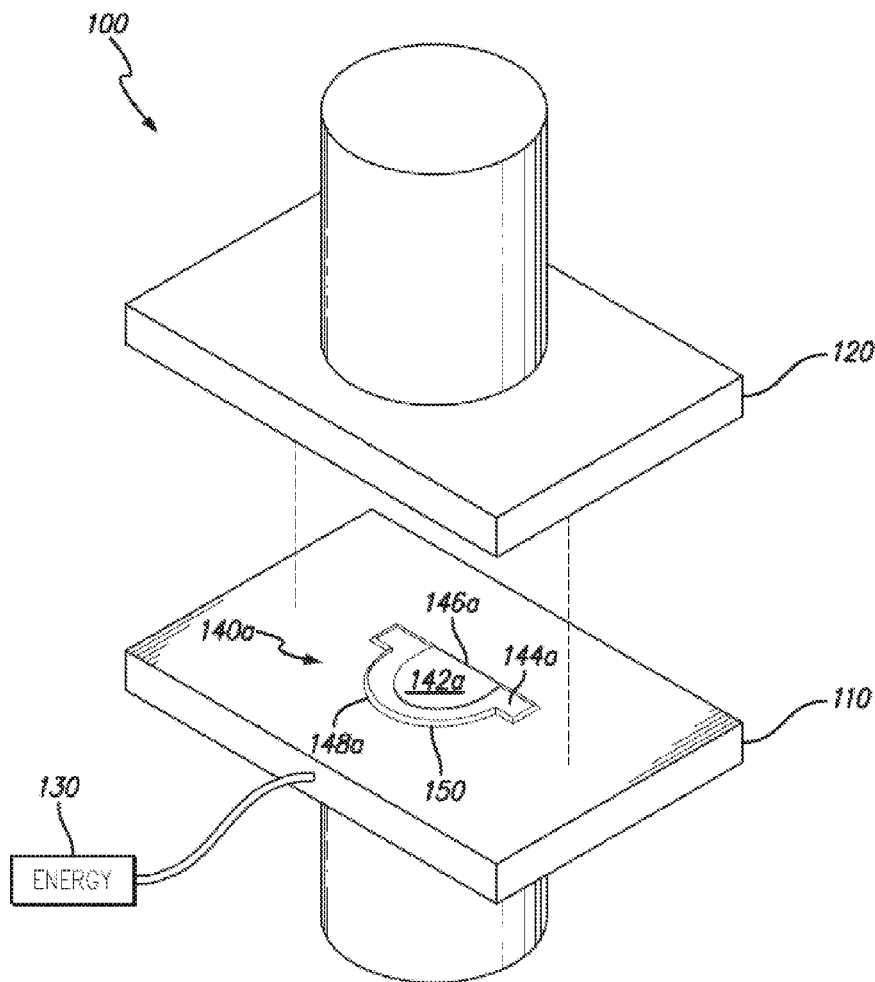

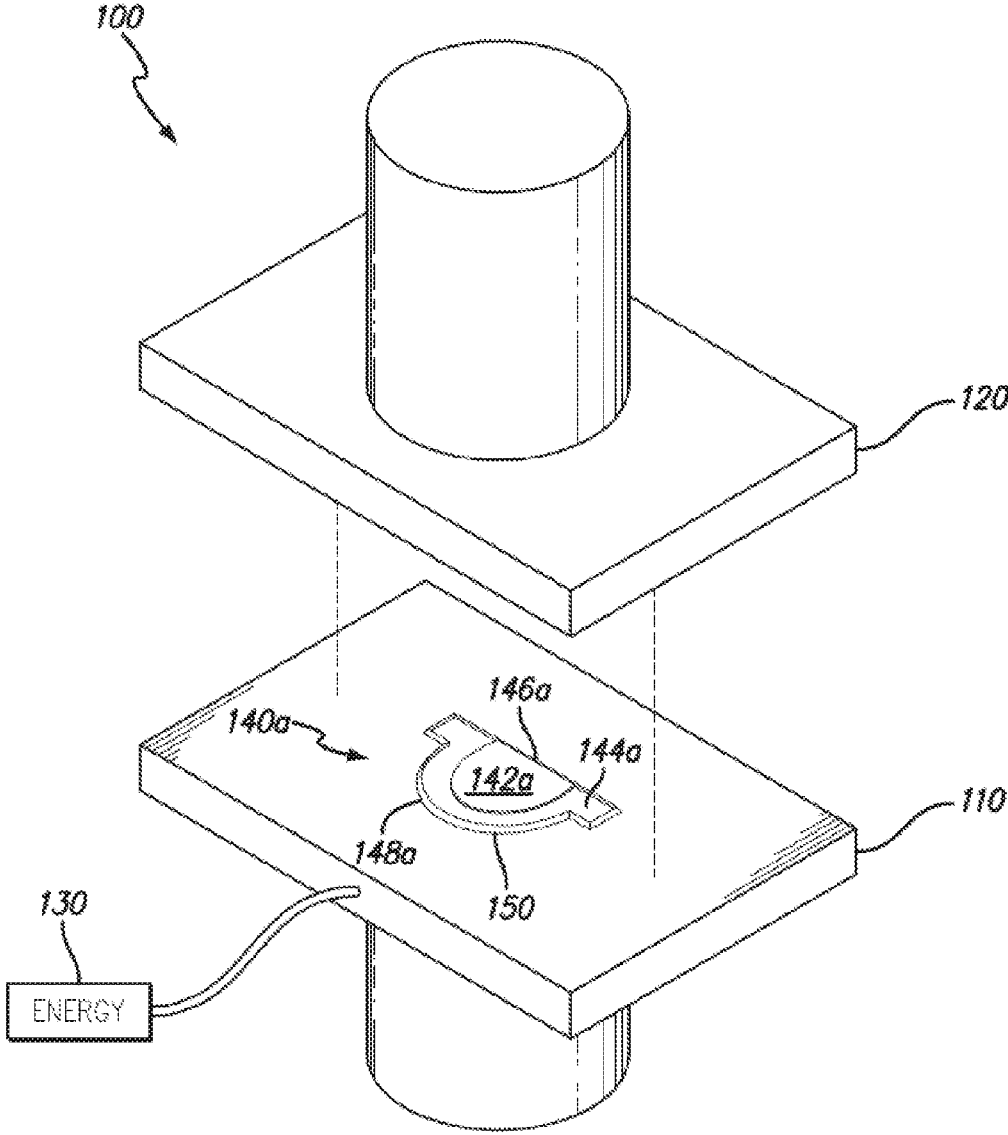

FIG. 1A

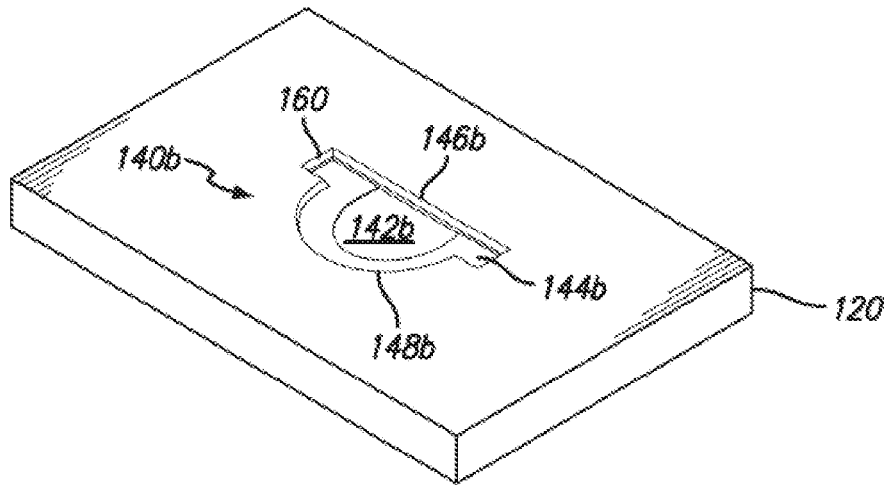

FIG. 1B

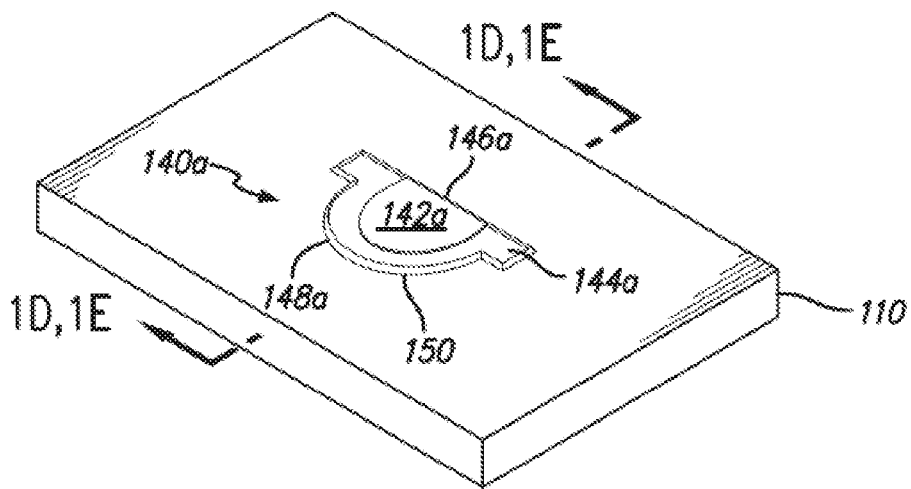

FIG. 1C

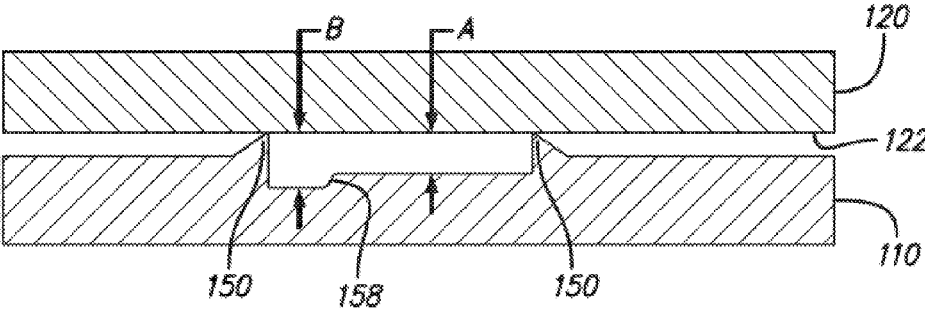

FIG. 1D

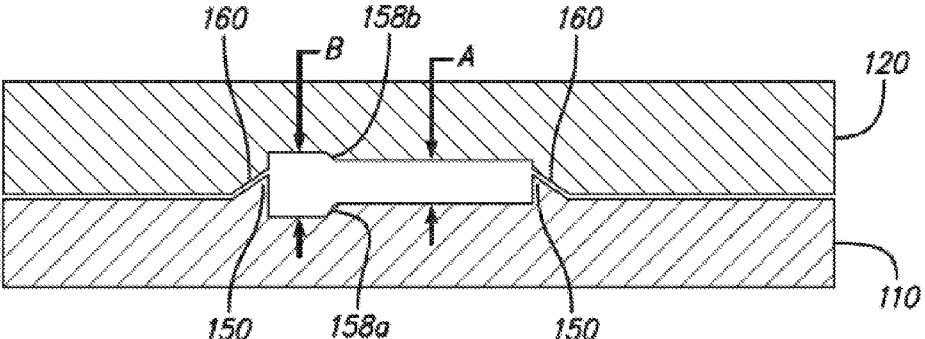

FIG. 1E

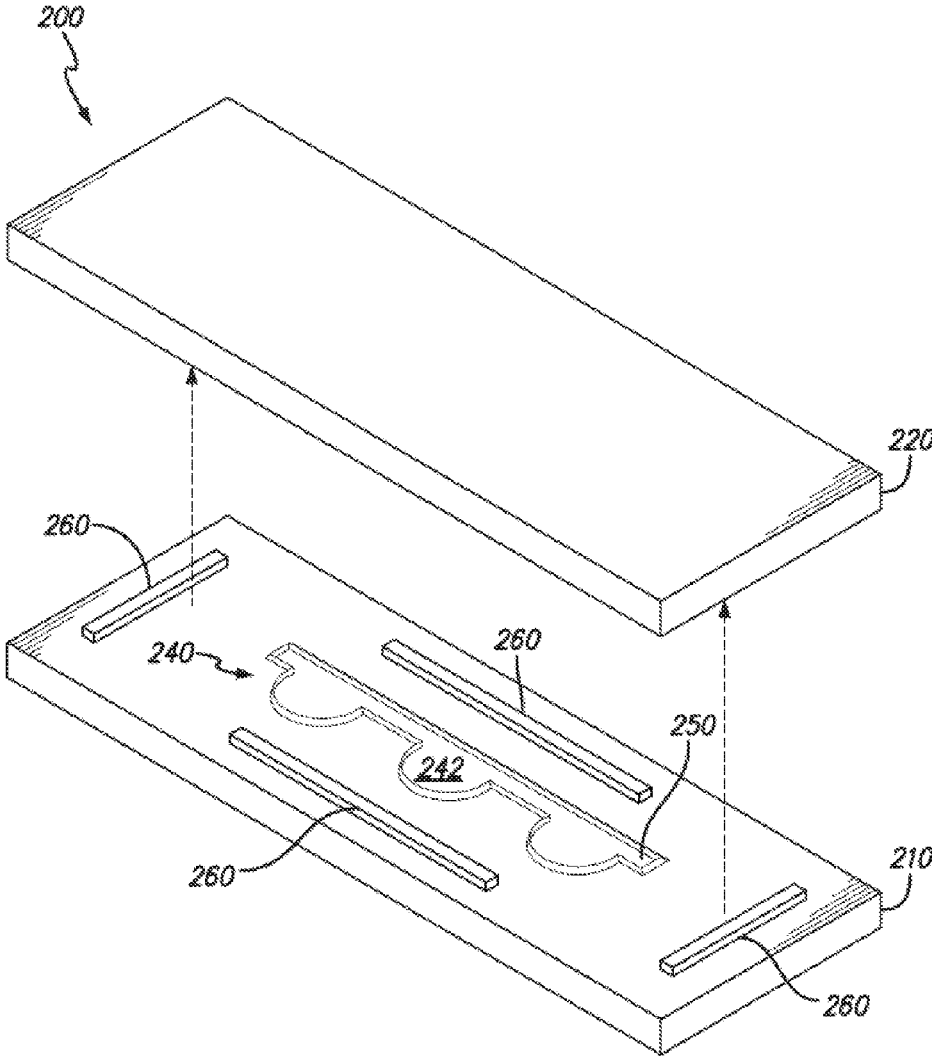

FIG. 2A

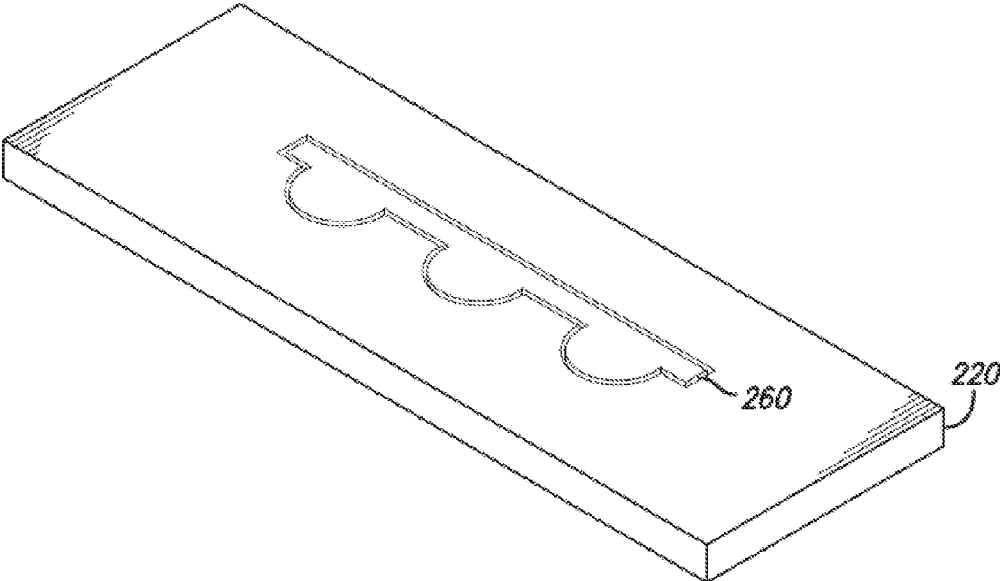

FIG. 2B

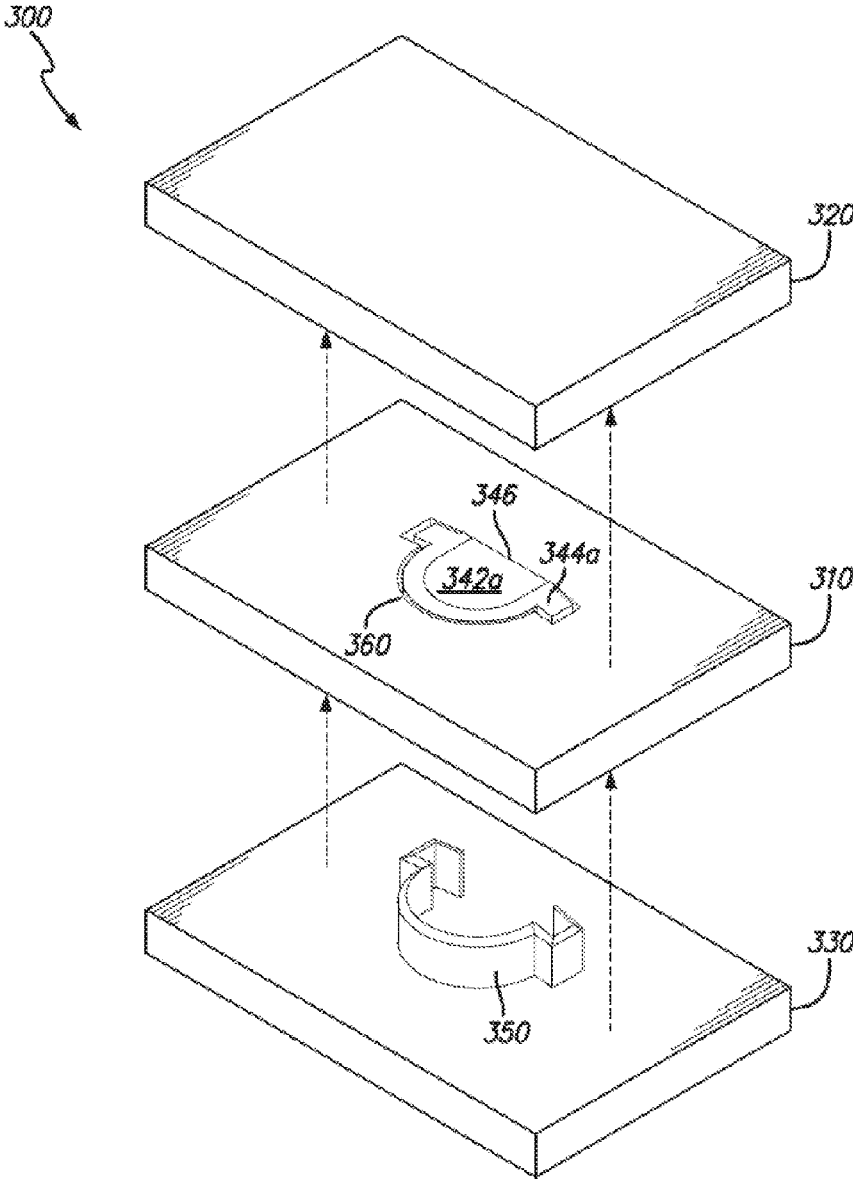

FIG. 3A

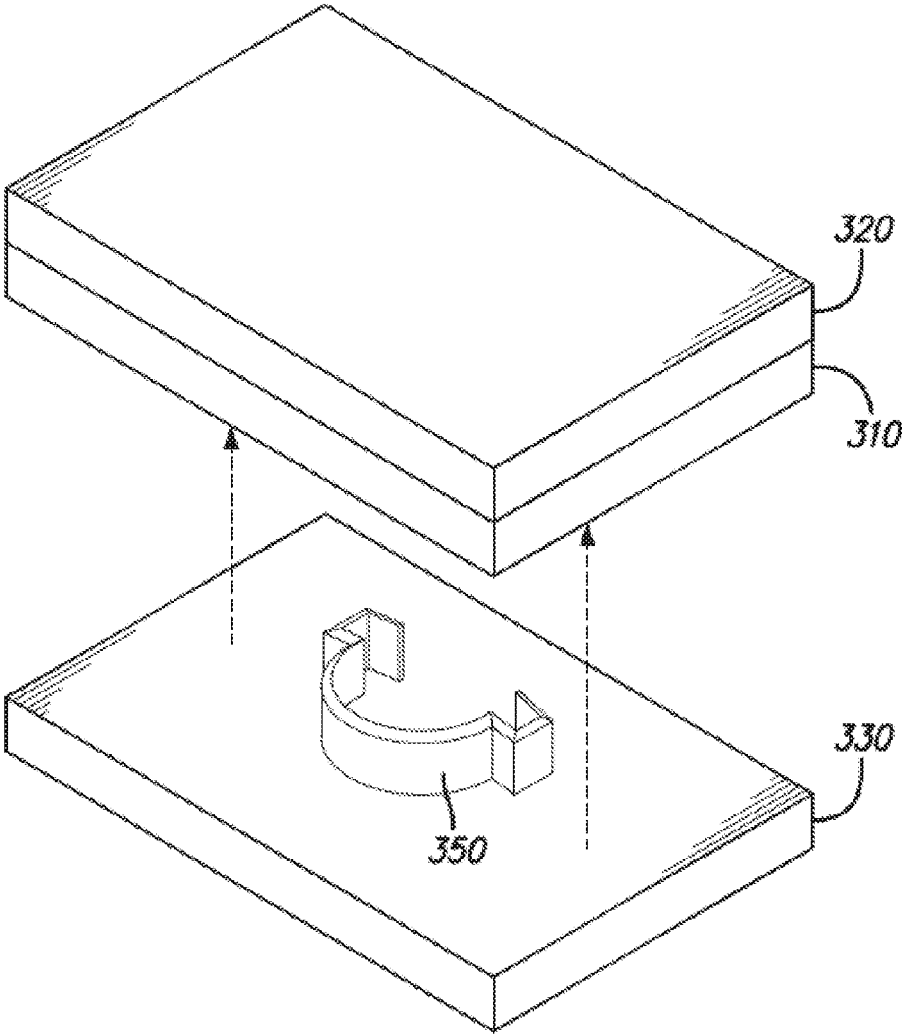

FIG. 3B

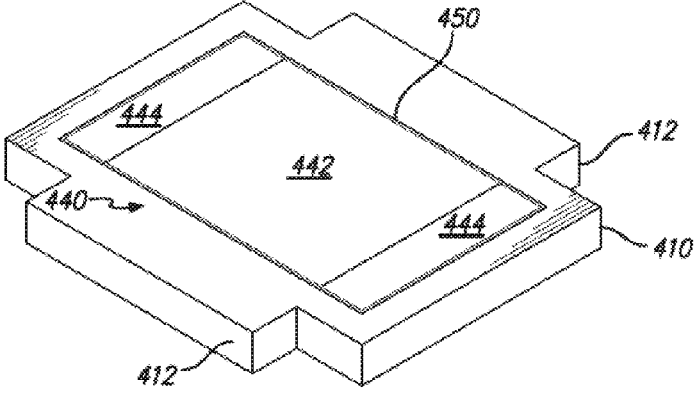

FIG. 4A

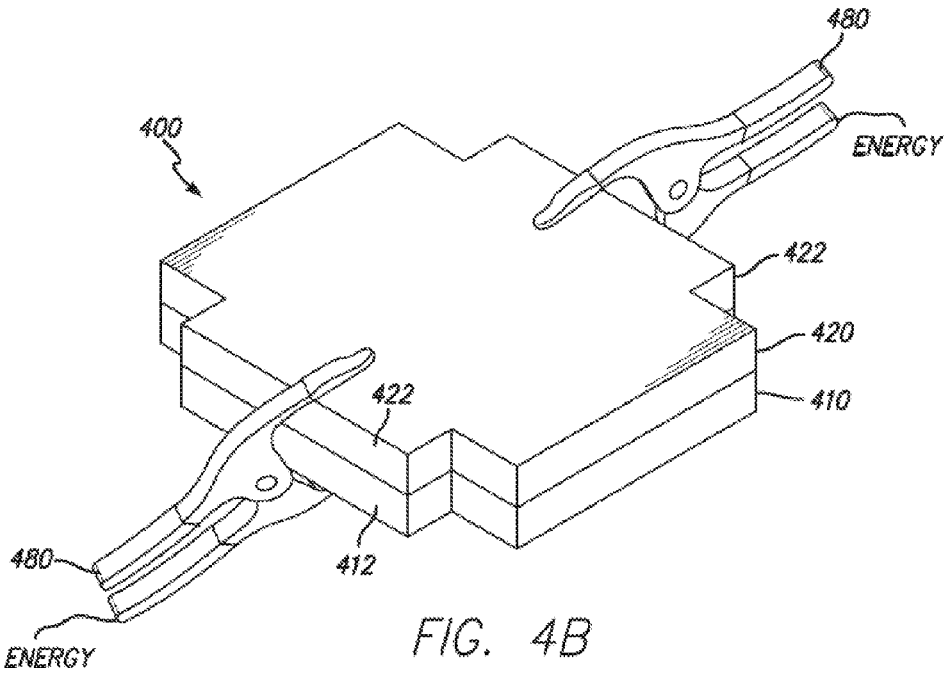

FIG. 4B

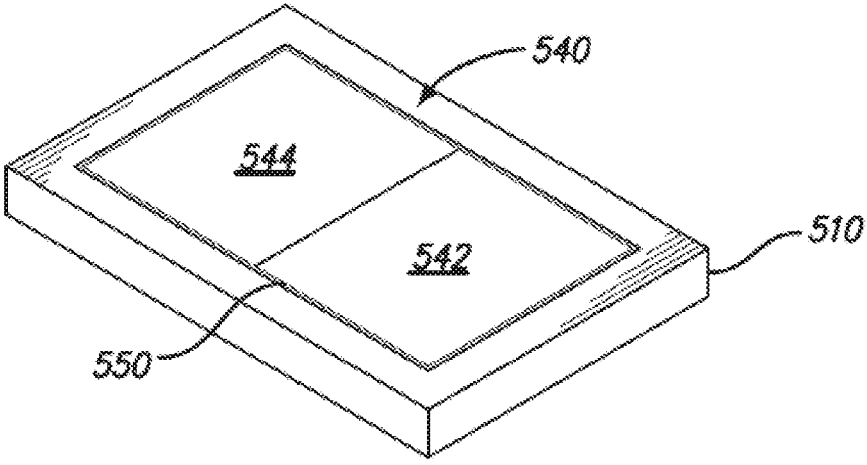

FIG. 5

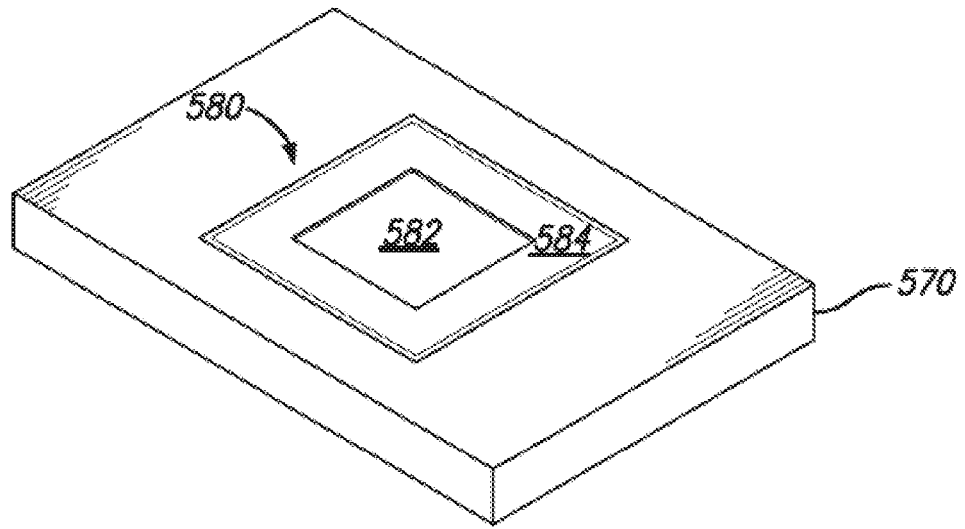

FIG. 6

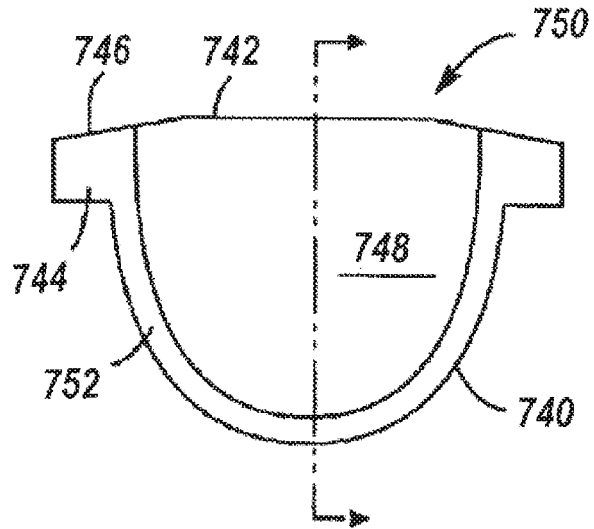

FIG. 7A

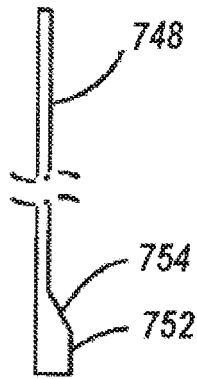

FIG. 7B

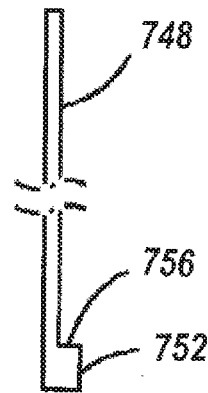

FIG. 7C

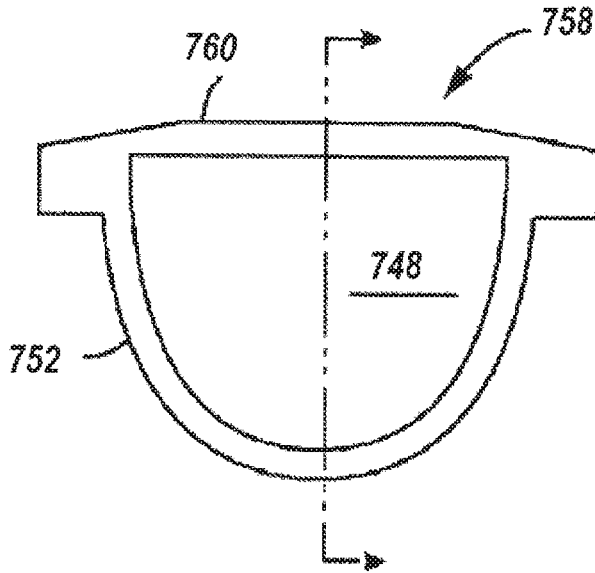

FIG. 8A

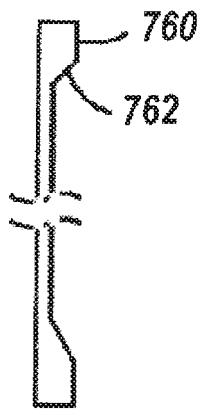

FIG. 8B

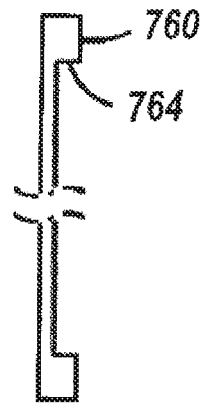

FIG. 8C

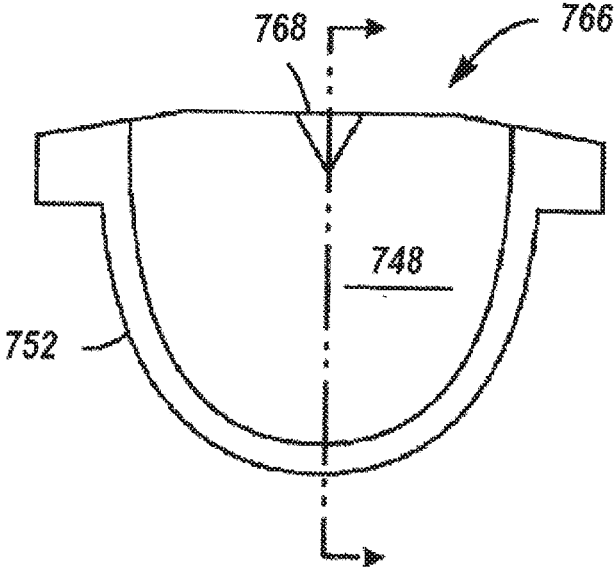

FIG. 9A

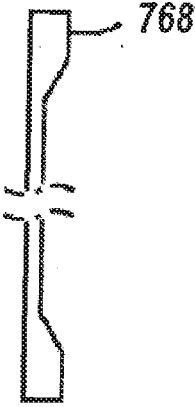

FIG. 9B

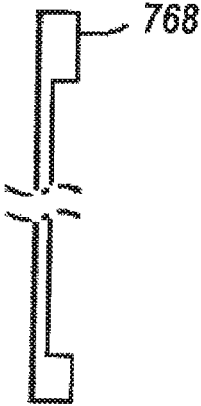

FIG. 9C

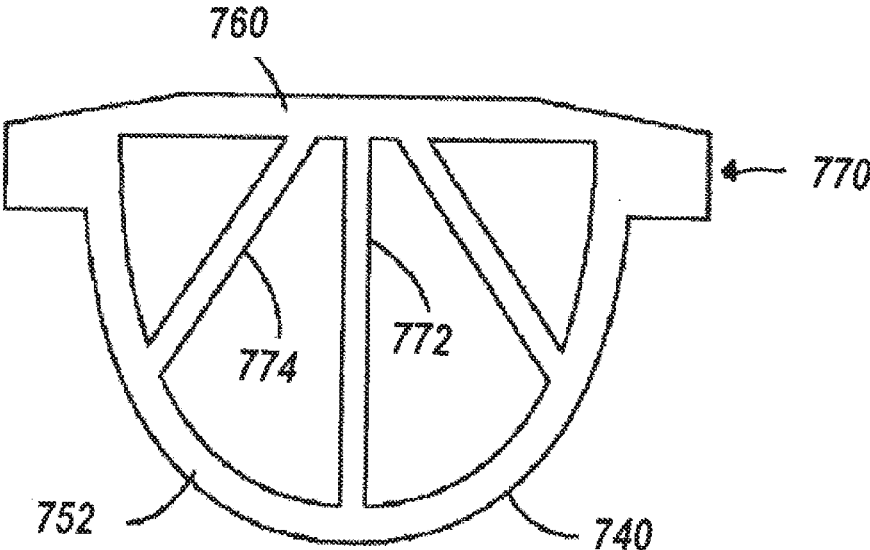

FIG. 10

METHOD AND APPARATUS FOR PREPARING A CONTOURED BIOLOGICAL TISSUE

CROSS REFERENCE TO RELATED APPLICATIONS

[0001] This application is a continuation of U.S. patent application Ser. No. 14/485,576, filed Sep. 9, 2014, now U.S. Pat. No. 9,615,922, which claims the benefit of U.S. patent application Ser. No. 61/884,775, filed Sep. 30, 2013, the entire disclosures of which are incorporated by reference in their entireties.

FIELD OF THE INVENTION

[0002] The present invention is directed to methods for treating bioprosthetic tissue for implantation in a patient and, more particularly, to methods for contouring and shaping biological tissue for use in connection with a bioprosthetic implant.

BACKGROUND

[0003] Minimally-invasive or percutaneous techniques for implanting bioprosthetic implants are commonly used in vascular and cardiovascular procedures. Such techniques involve the use of a delivery device, such as a catheter, to access a desired location via the patient's vasculature rather than using an open surgical approach where internal organs or tissue are exposed. The benefit of percutaneous procedures is in the ease of introducing devices into the patient without large cut downs, which can lead to long recovery times for patients.

[0004] One limitation of percutaneous procedures is the delivery profile of the bioprosthetic implant and delivery device. Because access to the desired implantation site is gained via the patient's vasculature, the delivery profile of the bioprosthetic implant and the delivery device, combined, must be sufficiently small so as to permit passage.

[0005] One method of reducing the delivery profile is to crimp the bioprosthetic implant about the delivery device. Crimping, however, may not reduce the delivery profile to a desired size due to the inherent bulk or configuration of the bioprosthetic implant. Therefore, changes are often required to the material and/or construction of the implantable bioprosthesis to permit crimping to yet smaller delivery profiles.

[0006] Replacement heart valves, for example, comprise a leaflet structure and a support structure. The leaflet structure is typically made from biological tissue, such as bovine pericardium, and the thickness of the tissue that makes up the leaflet structure limits the extent to which the heart valve can be crimped. Additionally, biological tissue will typically exhibit variations in thicknesses and these variations often produce unpredictable results with respect to the delivery profile of the crimped valves.

[0007] While the use of artificial or polymeric materials can offer a greater degree of control and flexibility to the resulting thickness of the material used for bioprosthetic implants, such materials may not always be desirable from at least a hemodynamic standpoint and may require the patient to take anticoagulants to prevent adverse effects from the interaction of the artificial material and the blood.

[0008] Another option is to remove excess portions of biological tissue so as to provide a thinner tissue having a

consistent thickness throughout. The loss of tissue, however, can undesirably compromise the fiber structure and therefore the strength of the tissue. Compression of the tissue to produce a thinner tissue may be desirable. The compressed tissue, however, may spring back to its original and uneven thickness after compressive forces are released.

[0009] Therefore, what is needed are methods and devices for preparing a biological tissue adapted for a bioprosthetic implant and which reliably reduces the delivery profile for use in minimally-invasive and percutaneous procedures.

BRIEF SUMMARY

[0010] The preferred embodiments described herein are directed to methods for treating biological tissue for use in connection with an implantable bioprosthesis. The entire disclosure of U.S. Patent Pub. No. 2011/0238167, published Sep. 29, 2011, to Edwards Lifesciences, Inc. is incorporated herein by reference in its entirety.

[0011] In one embodiment, an assembly for providing a contoured biological tissue is provided. The assembly comprises a first plate and a second plate. The first plate is configured to receive a biological tissue. The second plate is configured to contact and compress the biological tissue received on the first plate. One or both of the first and second plates comprise a defined shape and a contoured area within the defined shape. The contoured area comprises at least first and second elevations to achieve at least two different thicknesses in the biological tissue upon compression thereof. One or more energy sources is associated with one or both of the first and second plates. The one or more energy sources are configured to deliver energy upon compression of the biological tissue.

[0012] In some embodiments, the contoured area comprises a continuous transition between the first and second elevations.

[0013] In some aspects, the defined shape can be one or a plurality of heart valve leaflets, having a substantially straight free edge and an arcuate cusp edge.

[0014] In some aspects, the first elevation can be located at least along the arcuate cusp edge and the second elevation can be located between the arcuate cusp edge and the substantially straight edge.

[0015] In some aspects, the second elevation can contact a portion of the substantially free edge.

[0016] In some aspects, the contoured area further comprises a third elevation located within an area defined by the second elevation. The third elevation can comprise a substantially triangular shape, one side of which can contact a portion of the substantially straight edge.

[0017] In some aspects, the first elevation can substantially surround the second elevation.

[0018] In some aspects, the first elevation further comprises one or more radial regions extending from the substantially straight free edge to the arcuate cusp edge.

[0019] In some aspects, the defined shape is a parallelogram comprising a peripheral region and a central region, the first elevation being located along at least a portion of the peripheral region and the second elevation being located in the central region.

[0020] In some aspects, the defined shape is a parallelogram in which the first elevation is located in a portion constituting about half of the parallelogram and the second elevation is located in a remaining portion of the parallelogram

[0021] In some aspects, the assembly can further comprise a spacer disposed between the first and second plates, the spacer controlling a thickness of the compressed biological tissue.

[0022] In some embodiments, one of the first and second plates comprises a blade corresponding substantially to the defined shape, and the other of the first and second plates comprises a recess configured to receive the blade.

[0023] In some embodiments, the first plate can comprise a gap region corresponding substantially to the defined shape. The assembly can also include a third plate comprising a blade corresponding substantially to the defined shape, and which is configured to pass through the gap region of the first plate. The second plate can additionally include a recess configured to receive the blade.

[0024] In some aspects, the energy delivered by the one or more energy sources is preferably one or a combination selected from the group consisting of: thermal, ultrasound, electromagnetic, vibrational, hydraulic, piezoelectric, pneumatic, and acoustic and sound energy.

[0025] In another embodiment, a method for preparing a contoured biological tissue is provided. The method comprises compressing a layer of biological tissue between two plates to reduce a thickness of at least a portion of the biological tissue, delivering energy from an energy source to at least one of the two plates during the compressing, and cutting the biological tissue into a defined shape. The biological tissue following the compressing has at least two areas of different thicknesses.

[0026] In some aspects, the biological tissue following the compressing has a continuous transition between the at least two areas of different thicknesses.

[0027] In some aspects, the method comprises cutting the biological tissue into the defined shape via a blade associated with at least one of the two plates.

[0028] In some aspects, the method can further comprise treating the biological tissue with one or more fixatives to at least partially fix the tissue before, during, and/or after the compressing.

[0029] In some embodiments, the method can further comprise immersing the biological tissue disposed between the two plates in a solution comprising at least one fixative during and/or after the compressing.

[0030] In some aspects, the method can further comprise treating the biological tissue following the compressing with a capping agent, a reducing agent, and/or a collagen preserving agent. The capping agent can comprise an amine, the reducing agent can comprise a borohydride, and/or the collagen preserving agent can comprise glycerol.

[0031] In some aspects, provided is a contoured biological tissue prepared in accordance with the aforementioned method.

[0032] Other objects, features and advantages of the described preferred embodiments will become apparent to those skilled in the art from the following detailed description. It is to be understood, however, that the detailed description and specific examples, while indicating preferred embodiments of the present disclosure, are given by way of illustration and not limitation. Many changes and modifications within the scope of the present disclosure may be made without departing from the spirit thereof, and the disclosure includes all such modifications.

BRIEF DESCRIPTION OF THE DRAWINGS

[0033] Illustrative embodiments of the present disclosure are described herein with reference to the accompanying drawings, in which:

[0034] FIG. 1A is an exploded perspective view of an embodiment of an energized tissue compression assembly;

[0035] FIG. 1B is a perspective view of the bottom surface of the top compression plate of FIG. 1A;

[0036] FIG. 1C is a perspective view of the top surface of the bottom compression plate of FIG. 1A;

[0037] FIG. 1D is a cross-sectional view of an embodiment of a coupled first and second compression plates along axis 1D-1D of FIG. 1C;

[0038] FIG. 1E is a cross-sectional view of an embodiment of a coupled first and second compression plates along axis 1E-1E of FIG. 1C;

[0039] FIG. 2A is an exploded perspective view of an embodiment of a tissue compression assembly comprising spacers;

[0040] FIG. 2B is a perspective view of a bottom surface of the top plate of FIG. 2A;

[0041] FIGS. 3A and 3B are exploded perspective views of an embodiment of a tissue compression assembly and cutting plate;

[0042] FIG. 4A is a perspective view of one of a pair of tissue compression plates having a defined rectilinear shape;

[0043] FIG. 4B is a perspective view of the pair of tissue compression plates coupled together with energized clamps;

[0044] FIG. 5 is a perspective view of a further embodiment of a tissue compression plate having a rectilinear defined shape;

[0045] FIG. 6 is a perspective view of yet a further embodiment of a tissue compression plate having a rectilinear defined shape;

[0046] FIG. 7A is a plan view of a prosthetic heart valve leaflet having a thickened peripheral edge in areas where sutures penetrate for attachment to a structural stent;

[0047] FIGS. 7B and 7C are sectional views through a radial midline of the leaflet of FIG. 7A showing two different profiles;

[0048] FIG. 8A is a plan view of a prosthetic heart valve leaflet having a thickened peripheral edge in areas where sutures penetrate for attachment to a structural stent as well as a thickened free edge to reduce the risk of elongation at that location;

[0049] FIGS. 8B and 8C are sectional views through a radial midline of the leaflet of FIG. 8A showing two different thickness profiles;

[0050] FIG. 9A is a plan view of a prosthetic heart valve leaflet having thickened peripheral edge in areas where sutures penetrate for attachment to a structural stent as well as a thickened triple point area in the free edge simulating nodules of Arantius;

[0051] FIGS. 9B and 9C are sectional views through a radial midline of the leaflet of FIG. 9A showing two different thickness profiles; and

[0052] FIG. 10 illustrates in plan view an alternative leaflet having a thickened peripheral edge region, a thickened strip along the free edge, and a plurality of thickened radial strips extending from the free edge to the cusp edge.

[0053] Like numerals refer to like parts throughout the several views of the drawings.

DETAILED DESCRIPTION OF THE
PREFERRED EMBODIMENTS

[0054] Specific, non-limiting embodiments of the apparatus and methods for contouring bioprosthetic tissue will now be described with reference to the drawings. It should be understood that such embodiments are by way of example only and merely illustrative of but a small number of embodiments within the scope of the present disclosure. Various changes and modifications obvious to one skilled in the art to which the present disclosure pertains are deemed to be within the spirit, scope and contemplation of the present disclosure as further defined in the appended claims.

[0055] FIG. 1A depicts an energized tissue compression assembly 100 comprising a first bottom plate 110 and a second top plate 120. Each one of the first and second plates 110, 120 is coupled to an actuator (not depicted) which controllably displaces the first and second plates 110, 120 towards one another in direct physical contact and away from one another to release the compressed tissue (not shown).

[0056] Either one or both of the first and second plates 110, 120 can comprise a defined shape. In the embodiment depicted in FIGS. 1A-1C, both first and second plates 110, 120 comprise corresponding defined shapes in the form of a single heart valve leaflet 140a,b. The shape of the heart valve leaflet 140a,b depicted in FIGS. 1A-1C is characterized as having a substantially straight free edge 146a,b and an arcuate cusp edge 148a,b.

[0057] A contoured area is provided within the defined shape 140a,b. The contoured area comprises first and second elevations 142a,b and 144a,b and a transition defined therebetween. In the embodiment depicted in FIGS. 1A-1C, the first elevation 142a,b is provided as a substantially planar surface that is higher than or raised above the second elevation 144a,b, such that compression of a tissue disposed between the first and second plates 110, 120 would result in a tissue having at least two different thicknesses. Thus, the area of the tissue compressed between the first elevation 142a,b is thinner than the area of the tissue compressed between the second elevation 144a,b.

[0058] A blade 150 can additionally be provided on one of the first and second plates 110, 120. The blade 150 is depicted in FIGS. 1A and 1C as being disposed on the first bottom plate 110, with a corresponding recess 160 being defined in the second top plate 120 to receive the blade 150 and to permit direct contact between the facing surfaces of the first and second plates 110, 120 during compression as shown in FIG. 1E. FIG. 1E depicts the cooperation between the blade 150 of the first plate 110 and the corresponding recess 160 of the second plate as the first and second plates 110, 120 are actuated towards one another. In an alternative embodiment as depicted in FIG. 1D, only the first plate 110 can comprise the defined shape and the contoured area and the second plate 120 can be provided as a substantially flat and planar surface 122.

[0059] Compression of a biological tissue between the first and second plates 110, 120 results in a tissue having two different thicknesses, as indicated by A and B, and a continuous transition 158 between A and B. A continuous transition, as used herein, can be broadly understood to mean a transition which is curved or devoid of any sharply angled surfaces which are 90 degrees or less or, alternatively, devoid of any angled surfaces. The embodiments depicted in FIGS. 1D and 1E will result in a compressed

tissue having a continuous transition which is curved and devoid of any angled surfaces, whereas the compressed tissue depicted in FIGS. 7A, 8A and 9A show a continuous transition which is devoid of any sharply angled surfaces which are 90 degrees or less. The contoured tissue resulting from compression by the first and second plates 110, 120 of FIG. 1D will be substantially flat on one side and contoured on the other side, whereas the contoured tissue resulting from compression by the first and second plates 110, 120 of FIG. 1E will be substantially symmetrical along a bisecting plane across the compressed tissue. In both embodiments of FIGS. 1D and 1E, the tissue will be simultaneously compressed and cut to the defined shape by the contacting blade.

[0060] Static compression is not believed to be sufficient to restructure the collagen fiber density and orientation to produce a tissue that is uniform and that maintains the reduced thickness in the compressed state. Accordingly, an energy source 130 is depicted as being coupled to the first plate 110. It is understood that the energy source 130 can be connected to either one or both of the first and second plates 110, 120. The energy source 130 is configured to deliver one or a combination of thermal, ultrasound, electromagnetic, vibrational, hydraulic, piezoelectric, pneumatic, and acoustic and sound energy. The provision of energy to the biological tissue during compression is believed to facilitate a more effective collagen restructuring, as static compression without the provision of energy is believed to produce a tissue of non-uniform thickness over the compressed sample. This may be the case because the collagen fibers may not realign during static compression and thus do not become more isotropic after compression. As a more uniform tissue across a given compressed area is desired, the provision of energy during compression is believed to produce this result.

[0061] In accordance with a first aspect, the energy source 130 delivers vibrational energy to the tissue during compression. The application of directed vibrational energy during compression is believed to influence collagen fiber restructuring and also to make the collagen fiber alignment and density more uniform and predictable. While the tissue is being compressed under a high load, e.g., 1,000 lbs, vibrational energy can be sent through the tissue by one or both of the compression plates 110, 120. The vibration source can be a vibrating clamp (480, FIG. 4B) on the plates or a vibrating platform under the plates. While the tissue fibers are compressed, the vibration will cause shifting of the collagen fibers, possibly helping them fit together more tightly and thus permit compression to yet a more reduced thickness than would be possible in the absence of vibration. The shifting of the collagen fiber may also potentiate fiber redistribution so that the fiber density becomes more consistent in the tissue. Additionally, directing the vibration in certain directions can help the collagen fiber to realign to a more preferred orientation, making the tissue properties more predictable.

[0062] FIGS. 2A and 2B depict another embodiment of a tissue compression assembly 200 comprising a first plate 210 and a second plate 220. The first plate 210 is depicted as comprising a defined shape in the form of three heart valve leaflets having a recessed area 242 and a blade 250 provided in the defined shape. The second plate 220 comprises a recess 260 corresponding to the blade 250 disposed the first plate 210 and configured to receive the blade 250 within the recess 260 as the first and second plates 210, 220

are actuated toward each other in compressing engagement. Spacers **260** are provided to control the thickness of the resulting compressed and contoured tissue. The advantage of having a tissue compression assembly **200** comprising a plurality of heart valve leaflets is that it will obviate the need to suture each individual heart valve leaflet together. The spacers **260** can be provided in a range of thicknesses depending on the depth of the recessed area **242**. Thus, for more thinly compressed tissues, a correspondingly thinner spacer can be used and for more thickly compressed tissues, a correspondingly thicker spacer can be used. The defined shape of the three heart valve leaflets can have the same or similar contouring as depicted in FIGS. 1A-1E such that the tissue is compressed to two different thicknesses and has a continuous transition between the two thicknesses. Additionally, an energy source can also be provided to one or both of the first and second plates **210**, **220** to ensure to substantially maintain the tissue in its compressed state after the compression.

[0063] FIGS. 3A-3B depict yet another embodiment of a tissue compression assembly **300** in which blade **350** is provided separately on a third plate **330**. Thus, the first and second plates **310**, **320** are similar in substantial respects to the plates of FIGS. 1A-1C, except that the first plate **310** comprises a gap **360** surrounding a substantial portion of the defined shape to receive the blade **350** of the third plate **330**. As depicted in FIG. 3B, the tissue can be contoured by compression between the first and second plates **310**, **320** and the blade **350** of the third plate **330** can be inserted into the gap **360** of the first plate **310** to cut the contoured and compressed tissue to the desired shape. As can be seen in FIG. 3A, the gap **360** in the first plate **310** does not extend across the entirety of the defined shape so as to ensure that the defined shape remains supported by first plate **310**. In a preferred embodiment, all three plates, **310**, **320** and **330** are brought together and compressed, such that the tissue is compressed prior to or simultaneously with the cutting by the blade **350** disposed from the third plate **330**. In another embodiment, the first and second plates **310**, **320** apply the compression to the tissue disposed therebetween and the third plate **330** actuated towards the coupled first and second plates **310**, **320** to cut the compressed tissue therebetween (see FIG. 3B). It is understood that an energy source can be provided in the manner as described and depicted herein.

[0064] FIGS. 4A-4B depict yet another embodiment of a tissue compression assembly **400** comprising first and second plates **410**, **420**, wherein the first plate **410** comprises a rectilinear defined shape **440** having areas of different elevations **442**, **444**. The first elevation **442** can be higher than the second elevation **444** or vice versa. A tissue contoured in accordance with the tissue compression assembly **400** would be appropriate for fabricating, for example, an aortic conduit. The first and second plates **410**, **420** each have an area which is shaped to receive a vibrating clamp **480**. The directed vibration energy is applied by a vibrating clamp **480** at one or both ends **422** of the compression plates **410**, **420**. The clamp **480** sends vibrations through the plates from one side to the other. In another embodiment (not depicted) a vibrating platform can be provided upon which the compression plates **410**, **420** are placed. The entire platform can vibrate and the vibrations can be consistent over the platform or can be applied in waves, starting from one side of the platform and moving to the opposite side. Additionally, the vibration source can be the compression load head or

actuator (not depicted) itself. The head that comes down to apply the compressive load on the plates **410**, **420** can vibrate uniformly from one side to the other.

[0065] As with all the embodiments described herein, vibrational energy, thermal energy, ultrasound energy, electromagnetic energy, hydraulic energy, piezoelectric energy, pneumatic energy, and acoustic or sound energy can also be delivered to the tissue individually, sequentially, or in any number of combinations during compression and contouring.

[0066] Thermal energy is believed to weaken bonds in the tissue and to allow it to be compressed more easily. The tissue can be cooled during or after compression to set the new thickness. The heating source can be provided in multiple ways, such as by providing heated coils within or on top of one or both of the contoured plates, or lay using a heated liquid bath.

[0067] Ultrasound transducers can also be coupled to or otherwise associated with one or both of the first and second plates, or a liquid bath. Ultrasound energy is believed to create small cavities in the tissue to help break some of the bonds in the tissue. Prolonged exposure to ultrasound energy will also increase the temperature of the tissue, making it easier to break bonds. Applying a mechanical compression load while heating and/or applying ultrasound energy to the tissue can increase compressibility and reduce rebound. Ultrasound energy can be applied to the tissue before, during and/or after the compression. In a preferred embodiment, ultrasound energy is applied at least during the compression.

[0068] Electromagnetic energy can also be provided as an energy source during compression and contouring. The electromagnetic energy can be microwave or RF or infrared and provided by a source such as an RF or microwave antenna embedded in a non-conducting plate or a printed circuit antenna insulated from the tissue itself. The electromagnetic energy can be delivered alone or in combination with any one or more of the other energy sources. In a preferred embodiment, electromagnetic energy is applied before, during and/or after the compression. In a preferred embodiment, electromagnetic energy is applied at least during the compression.

[0069] FIGS. 5-6 depict yet further alternate embodiments of a first plate having different defined shapes.

[0070] In FIG. 5, the first plate **510** of a tissue compression assembly is provided as having a defined shape **540** of a rectilinear polygon having two different elevations **542**, **544** and a blade **550** surrounding the defined shape. A second plate (not depicted) can be provided having the mirror image of the defined shape **540** of the first plate **510**, including the two different elevations **542**, **544**. Alternatively, the second plate can be a substantially flat plate, preferably comprising grooves to receive the blade **550** provided on the first plate **510**.

[0071] In another embodiment, the defined shape can be a rectilinear polygon in which about the first elevation is defined in an area constituting about half of the rectilinear polygon and the second elevation is defined on a remaining portion of the rectilinear polygon.

[0072] In FIG. 6, the first plate **570** comprises the defined shape **580** of a square having different elevations **582**, **584**. Again, a second plate (not depicted) can be provided having the mirror image of the defined shape **580** including the different elevations **582**, **584**. Alternatively, the second plate can be a substantially flat plate, preferably comprising

grooves to receive a blade provided on the first plate. The first elevation 582 can be raised above the second elevation 584 so as to produce a compressed tissue having a thinner central area corresponding to the first elevation 582 and a thicker periphery corresponding to the second elevation 584. Alternatively, the second elevation 584 can be raised above the first elevation 582 so as to produce a compressed tissue having a thinner peripheral area and a thicker central area.

[0073] FIGS. 7-9 illustrate alternative thickness profiles in pericardial tissue prosthetic heart valve leaflets from the selective thinning processes described herein. Each of the leaflets is shown in plan view and has an arcuate cusp edge 740, a generally straight free edge 742 opposite the cusp edge 740, and a pair of oppositely-directed tabs 744 at either end of the free edge. Each of the tabs 744 includes a tapered side 746 which transitions to the free edge 742. A central portion 748 in each of the leaflets forms the fluid occluding surface that oscillates in and out of the flow stream to alternately open and close the valve. This shape is exemplary only, and other leaflet shapes are known. Each of the leaflets shown in FIGS. 7-9 have the same shape, and thus the same element numbers for the shape characteristics will be used.

[0074] FIG. 7A illustrates a leaflet 750 having a thickened peripheral edge region 752 in areas where sutures penetrate for attachment to a structural stent (not shown). More particularly, the thickened peripheral edge region 752 extends around the entire cusp edge 740 and up into at least a portion of the tabs 744. As mentioned, these are areas in which sutures are used to attach the leaflet to a supporting stent or skirt. The thickness of the peripheral edge region 752 can be up to 700 microns, preferably about 250-700 microns. At the same time, the central portion 748 is formed to have a relatively small thickness, thus facilitating a smaller delivery profile for valves that are compressed. For instance, a uniform thickness of about 100 to 250 microns for the central portion 748 is believed particularly useful to reduce the crimped profile of collapsible/expandable valves, though uniform thicknesses between 250-500 microns can be suitable.

[0075] FIGS. 7B and 7C are sectional views through a radial midline (vertical) of the leaflet of FIG. 7 showing two different thickness profiles. FIG. 7B illustrates a gradual ramp 754 between the thick edge region 752 and thinner central portion 748. The ramp 754 is shown linear, although other contours such as curved or gradually stepped can be used. In contrast, FIG. 7C illustrates the thicker peripheral edge region 752 transitioning to the thinner central portion 748 at a relatively abrupt step 756. It is believed the more gradual ramp 754 depicted in FIG. 7B provides a more desirable stress distribution and flow over the leaflet than the step 756. It is possible to provide gradual and continuous transitions by shaping the transition between the two elevations provided in the first and second plates in a curved manner, devoid of sharply angled areas. As depicted in FIGS. 7B, 8B and 9B, the transition between the first and second elevations is continuous insofar as it is angled (θ_1) at greater than 90 degrees. In contrast, FIGS. 7C, 8C, and 9C depict the transition between the first and second elevations is regarded as non-continuous insofar as it is angled (θ_2) at 90 degrees or less.

[0076] FIG. 8A is a plan view of a prosthetic heart valve leaflet 758 having a thickened peripheral edge region 752 as seen in FIG. 7A, as well as a thickened strip 760 along the

free edge 742. Prosthetic heart valves sometimes fail from elongation of the free edge of the leaflet where the leaflets come together, or coapt, which ultimately may cause prolapse of the valve. Providing the thickened strip 760 along the entire free edge 742 reduces the risk of elongation, as the stresses experienced by free edge are proportional to its thickness. FIGS. 8B and 8C again show two different thickness profiles for the leaflets of FIG. 8A, wherein the thickened peripheral edge region 752 and thickened strip 760 can transition to the thinner central portion 748 at a continuous transition 762 (FIG. 8B) or steps 764 (FIG. 8C).

[0077] FIG. 9A illustrates a heart valve leaflet 766 again having the thickened peripheral edge 752 in areas used for attachment to a structural heart valve stent. In addition, the leaflet 766 has a thickened triple point area 768 in middle of the free edge 742 simulating a nodule of Arantius. To clarify, the so-called triple point in a heart valve leaflet is the point where the leaflet comes together (coapts) with the other leaflets in the center of the flow orifice. Because the three leaflets curve into the middle, a gap therebetween at the triple point can be sufficient to cause regurgitation. In native leaflets, the center of the free edge sometimes has a thickened area known as the nodules of Arantius that tends to fill the gap at the triple point. When using uniform thickness pericardial tissue for the leaflets, leakage can only be avoided by having a long coapting surface that requires extra leaflet material. However, that can adversely impact the ability to compress a valve to a low profile, and sometimes results in distortion of the leaflet when it closes which might result in early calcification. By producing a thickened triple point area 768 in each of the leaflets, a nodule of Arantius can be simulated. The exemplary triple point area 768 is shown as a small triangle in the center of the free edge 742, although the shape could be curved such as a semi-circle, or other shapes. Furthermore, the triple point area 768 can be combined with the thickened strip 760 along the free edge 742, such as seen in FIG. 8A. Indeed, any of the various thickened regions described herein can be combined with other regions for a desired effect.

[0078] FIGS. 9B and 9C show two different thickness profiles for the leaflet 766. FIG. 9B shows gradual transitions between the thinner central portion 748 and both the thickened peripheral edge 752 and the thickened triple point area 768, while FIG. 9C shows abrupt steps at the same locations.

[0079] FIG. 10 illustrates an alternative leaflet 770 of the present application that can help reduce sagging in leaflets, which has been found as a cause of failure in some prosthetic heart valves. Resistance to leaflet elongation is directly proportional to leaflet thickness along radial stress lines. Therefore, in addition to a thickened peripheral edge region 752 and a thickened strip 760 along the free edge 742, the leaflet 770 includes a plurality of thickened radial strips 772, 774 extending from approximately the middle of the free edge 742 to the arcuate cusp edge 740. The "radial lines" in this sense are drawn as if the cusp edge 740 was the edge of a circle centered in the middle of the free edge 742, though it should be understood that the cusp edge 740 is not defined by a single arc, and may not be centered at the free edge 742. Typically, prosthetic leaflets are symmetric about a radial midline, however, and thus one preferred arrangement includes a thickened radial strip 772 along the midline (vertical), and symmetric thickened radial strips 774 on either side of the vertical strip 772. In the illustrated embodi-

ment, there are three strips; a midline strip 772 and two radial strips 774 at approximately 30° angles from the middle strip. It should also be noted that as illustrated, the various thickened strips around the leaflet are of approximately the same width, though such does not have to be the case. For example, the cusp edge strip 760 and radial strips 772, 774 can be substantially thinner than the edge region 752 through which sutures must pass.

[0080] One contemplated sequence for conditioning tissue includes first cross-linking the tissue (e.g., bovine pericardium) with a glutaraldehyde-buffered solution. Next, the tissue can be heat treated using a process such as disclosed in U.S. Pat. No. 5,931,969 to Carpentier, issued Aug. 3, 1999, the disclosure of which is expressly incorporated herein by reference in its entirety. Subsequently, the thickness of the tissue can be reduced using any of the methods disclosed in the present application. Finally, the thinner tissue can be treated with a capping and/or reducing agent to mitigate later in vivo calcification; this can also include treating with a glycerol/ethanol solution such as is disclosed in U.S. Pat. No. 7,972,376, issued Jul. 5, 2011 to Edwards Lifesciences Corp., the content of which is incorporated herein by reference in its entirety. The thinner tissue can also be at least partially dehydrated or dried by other chemical or non-chemical means to permit storage of the compressed and contoured tissue in a non-fluid environment. Alternatively, the tissue can be at least partially dehydrated or dried prior to compression. Methods of treating tissue to at least partially dehydrate or dry the tissue, as compared to its native state, are disclosed in U.S. Pat. No. 8,007,992, issued Aug. 30, 2011 to Edwards Lifesciences, Corp. and U.S. Pat. No. 6,534,004, issued Mar. 18, 2003 to The Cleveland Clinic Foundation, the entire contents of which are incorporated herein by reference in their entireties.

[0081] For prosthetic heart valve leaflets, the compressed and contoured leaflets are attached to a surrounding heart valve support frame or other such components, and sterilized such as with ethylene oxide. After the tissue has been compressed and contoured to reduce its thickness, calcification nucleation sites (e.g., aldehydes and Schiff bases) can be exposed which creates a propensity for calcification. Treating with a capping agent (e.g., ethanolamine) a reducing agent (e.g., sodium borohydride) and a collagen preserving agent (e.g., glycerol) caps the nucleation sites and preserves the collagen integrity. This allows the tissue to be as durable as it was before it was reduced in thickness. Furthermore, this process will also allow the tissue to be stored in a non-liquid environment. In other words, the process is especially suitable for dry storage of the tissue.

[0082] As noted above, the tissue can be at least partially cross-linked or “fixed.” Cross-linking the collagenous matrix provides stability prior to implantation to retard degeneration. Further, the fixation process generally operates by blocking reactive molecules on the surface of and within the donor tissue, thereby rendering it substantially non-antigenic and suitable for implantation. Fixing bioprosthetic tissue typically involves contacting the tissue with a cross-linking agent, normally a solution. Exemplary fixing solutions for bioprosthetic tissue such as bovine pericardium include glutaraldehyde, formaldehyde, other aldehydes, EDC, polyethylene glycol, etc. Other ways to fix tissue exist, including heating, irradiating, etc. The fixing step can help

maintain the pericardium in a particular three-dimensional form if undertaken after the membrane is otherwise prepared.

[0083] It should be understood that although cross-linking the tissue results in a somewhat easier to handle work piece, the compressing and contouring can occur prior to cross-linking as well. Likewise, bulk tissue sheet can be compressed and contoured first before or after fixing, or leaflets can first be cut from the bulk membrane which are then compressed and contoured before or after fixing.

[0084] Accordingly, the biological tissue can first be fixed with glutaraldehyde or other fixing agent before the compression and contouring. In one embodiment, the tissue can be soaked with a fixative before the compressing. The fixative can be glutaraldehyde and/or a 0.1% polyetheramine solution having an average molecular weight of about 600 and a pH of about 6 to 9. The tissue can be rinsed with a saline before the soaking and after the compression.

[0085] This first fixation step stabilizes the biomechanics of the tissue and preserves the natural “crimp” structure of the collagen.

[0086] In a preferred embodiment, a second fixation step is provided after the first fixation step and before, during and/or after the compressing and contouring. Infusion with a second fixing agent of sufficient chain length to allow spanning of large inter-fibril domains can result in a stable tissue membrane. Second fixative agents include di- or poly-amine material of substantial chain length can be employed. Other cross-linking material to span large inter-fibril domains include both linear and branched polyethyleneimine, polyvinyl alcohol and various Jeffamine polymers, polyetheramines, di- and poly-amines, polyurethanes, polyepoxies, polysiloxanes, polyacrylates, polyesters, poly block isobutylene-co-maleic acid, collagen, elastin, fibrin, hyaluronic acid, dextrin, genapin, di or poly-alkynes, di- or poly-azides, and tannins. Alternatively, the tissue can be oxidized with, for example, sodium chlorite to convert the newly formed aldehydes to carboxylic acids. These can then be coupled with the above amines using EDC chemistry. Compression can occur either at the beginning of the process, after infusion with a second fixing material, or both. The tissue can be capped and reduced following the first fixation step, or alternatively, the compressed and cross-linked tissue can be stabilized by capping and borohydride reduction after the contouring.

[0087] In a preferred embodiment, the tissue is treated with a first fixative before the compressing and then treated with a second fixative before, during or after the compressing, preferably during and, more preferably both during and after the compressing. To that end, one or both of the first and second plates used to compress the tissues, as disclosed herein, can be made of a porous substrate to permit the infusion of or submission in a solution comprising one or both of the first and second fixative during the compression.

[0088] In a preferred embodiment, the second fixing cross-links the biological tissue by utilizing a combination of an anchor compound and a difunctional linking compound, each one of which comprises complementary ones of a bio-orthogonal binding pair. One advantage is that the reaction between the bio-orthogonal binding pair is highly specific only to each other, thereby reducing or even eliminating the possibility of undesired side reactions between any one of the bio-orthogonal binding pair with tissue functional groups present in or native to biological tissue.

[0089] As used herein, “bio-orthogonal binding pair” refers to a pair of functional groups which react with and couple one another within a biological tissue. The reaction and coupling between complementary ones of the bio-orthogonal binding pair is mutually exclusive such that each one of the bio-orthogonal binding pair does not react with any tissue functional groups or with any functional groups found inside living systems.

[0090] As used herein, “tissue functional groups” refer to functional groups which are native to biological tissue and, more particularly, in collagenous tissue, such as, for example, cardiac valves, blood vessels, skin, dura mater, pericardium, small intestinal submucosa (“SIS tissue”), ligaments and tendons. Exemplary tissue functional groups include amines, hydroxyls, sulfhydryls, aldehydes, and carboxylic acids.

[0091] In a preferred embodiment, the bio-orthogonal binding pair comprises an azide and an acetylene. It is understood that the azide and acetylene groups of the bio-orthogonal binding pair can be present as either a terminal or an internal group within an anchor compound or a linking compound used in accordance with the method. While the reaction of the bio-orthogonal binding pair itself is specific to one another, one or both of the anchor compound or the linking compound can comprise additional functional groups, such as those which react with tissue functional groups which can be reactive with other functional groups, such as tissue functional groups. However, it is understood that the additional functional groups of the first or linking compound are not reactive with either one of the bio-orthogonal binding pair.

[0092] The invention described and claimed herein is not to be limited in scope by the specific preferred embodiments disclosed herein, as these embodiments are intended as illustrations of several aspects of the invention. Indeed, various modifications of the invention in addition to those shown and described herein will become apparent to those skilled in the art from the foregoing description. Such modifications are also intended to fall within the scope of the appended claims.

What is claimed is:

1. An assembly for providing a contoured biological tissue, the assembly comprising:

a first plate configured to receive a biological tissue;
a second plate configured to contact and compress the biological tissue received on the first plate;

wherein one or both of the first and second plates comprise a defined shape and a contoured area within the defined shape, the contoured area comprising at least first and second elevations to achieve at least two different thicknesses in the biological tissue upon compression thereof; and

an energy source associated with one or both of the first and second plates and configured to deliver energy upon compression of the biological tissue.

2. The assembly of claim 1, further comprising a continuous transition between the first and second elevations.

3. The assembly of claim 1, wherein the defined shape comprises a substantially straight free edge and an arcuate cusp edge.

4. The assembly of claim 3, wherein the first elevation is located along at least the arcuate cusp edge and the second elevation is located between the arcuate cusp edge and the substantially straight free edge.

5. The assembly of claim 4, wherein the second elevation contacts a portion of the substantially straight free edge.

6. The assembly of claim 4, further comprising a third elevation located within an area defined by the second elevation.

7. The assembly of claim 6, wherein the third elevation comprises a substantially triangular shape, one side of which contacts a portion of the substantially straight free edge.

8. The assembly of claim 4, wherein the first elevation substantially surrounds the second elevation.

9. The assembly of claim 8, wherein the first elevation further comprises one or more radial regions extending from the substantially straight free edge to the arcuate cusp edge.

10. The assembly of claim 1, wherein the defined shape is a parallelogram comprising a peripheral region and a central region, the first elevation being located along at least a portion of the peripheral region and the second elevation being located in the central region.

11. The assembly of claim 1, wherein the defined shape is a parallelogram in which the first elevation is located in a portion constituting about half of the parallelogram and the second elevation is located in a remaining portion of the parallelogram.

12. The assembly of claim 1, further comprising one or more spacers disposed between the first and second plates, the one or more spacers controlling a thickness of the compressed biological tissue.

13. The assembly of claim 1, wherein one of the first and second plates comprises a blade corresponding substantially to the defined shape, and wherein the other of the first and second plates comprises a recess configured to receive the blade.

14. The assembly of claim 1, further comprising:

a gap region in the first plate corresponding substantially to the defined shape;

a third plate comprising a blade configured to pass through the gap region; and

a recess in the second plate configured to receive the blade.

15. The assembly of claim 1, wherein the energy delivered by the energy source is one or a combination selected from the group consisting of: thermal, ultrasound, electromagnetic, and vibrational.

16. A method for preparing a contoured biological tissue comprising:

compressing a layer of biological tissue between two plates to reduce a thickness of at least a portion of the biological tissue;

delivering energy from an energy source to at least one of the two plates during the compressing, wherein the biological tissue following the compressing has at least two areas of different thicknesses; and

cutting the biological tissue into a defined shape.

17. The method of claim 16, wherein the biological tissue is cut into the defined shape via a blade associated with at least one of the two plates.

18. The method of claim 16, wherein the biological tissue following the compressing comprises a continuous transition between the at least two areas of different thicknesses.

19. The method of claim 16, further comprising treating the biological tissue with one or more fixatives to at least partially fix the biological tissue before, during, or after the compressing.

20. The method of claim **16**, further comprising immersing the biological tissue disposed between the two plates in a solution comprising at least one fixative during and/or after the compressing.

21. The method of claim **16**, further comprising treating the biological tissue following the compressing with a capping agent, a reducing agent, and/or a collagen preserving agent.

22. The method of claim **21**, wherein the capping agent comprises an amine.

23. The method of claim **21**, wherein the reducing agent comprises a borohydride.

24. The method of claim **21**, wherein the collagen preserving agent comprises glycerol.

25. A contoured biological tissue prepared in accordance with the method of claim **16**.

* * * * *