



(19) **United States**

(12) **Patent Application Publication**
Dowlatkah et al.

(10) **Pub. No.: US 2016/0366550 A1**

(43) **Pub. Date: Dec. 15, 2016**

(54) **LOCATING A DEVICE VIA A TEXT MESSAGE**

(52) **U.S. Cl.**

CPC *H04W 4/02* (2013.01); *H04W 12/06* (2013.01); *H04W 4/14* (2013.01); *H04L 63/12* (2013.01)

(71) Applicant: **AT&T Intellectual Property I, L.P.**,
Atlanta, GA (US)

(72) Inventors: **Sangar Dowlatkah**, Alpharetta, GA (US); **Venson M. Shaw**, Kirkland, WA (US)

(57) **ABSTRACT**

(21) Appl. No.: **15/250,096**

(22) Filed: **Aug. 29, 2016**

Related U.S. Application Data

(63) Continuation of application No. 14/093,192, filed on Nov. 29, 2013, now Pat. No. 9,439,032.

Publication Classification

(51) **Int. Cl.**
H04W 4/02 (2006.01)
H04W 4/14 (2006.01)
H04W 12/06 (2006.01)

A first device may receive a location of a second device simply by sending a text message to the second device. The text message may comprise an identifier of the second device (e.g., phone number of the second device, mobile subsection identification number of the second device, etc.) and a location code. A communication network may intercept the text message. The communication network may analyze contents of the text message. The network may determine that the location code is valid and determine the location of the second device. The network may provide an indication of the location of the second device to the first device.

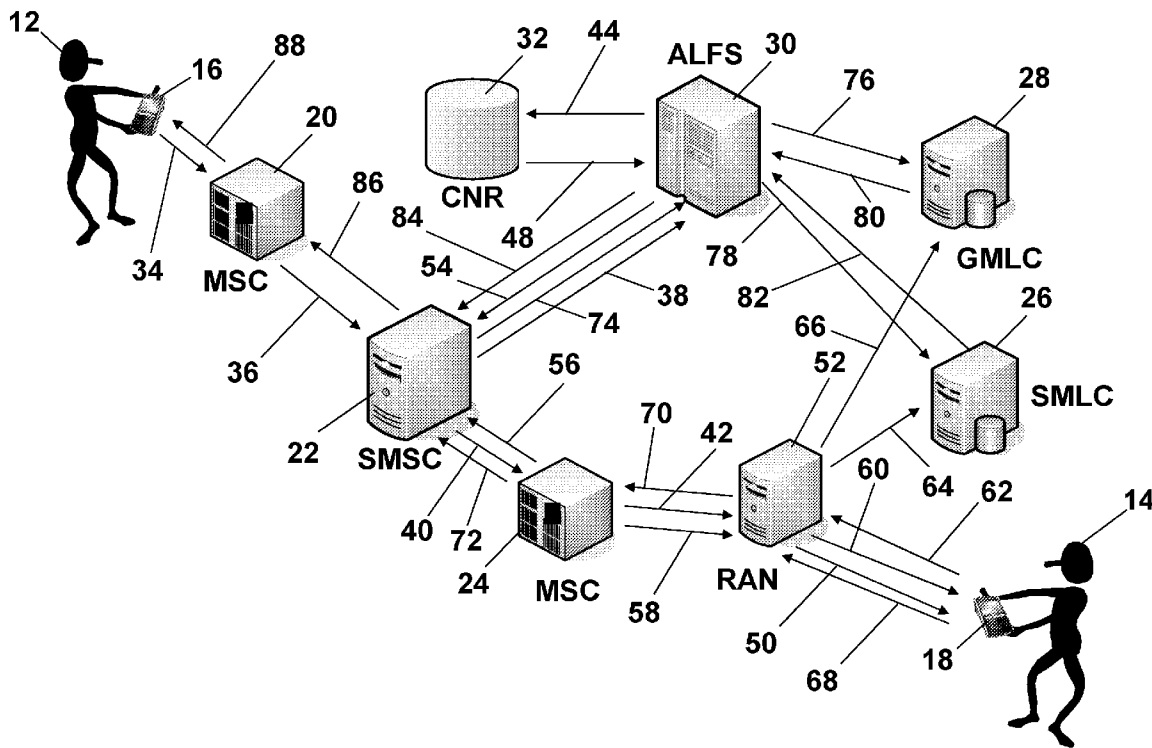

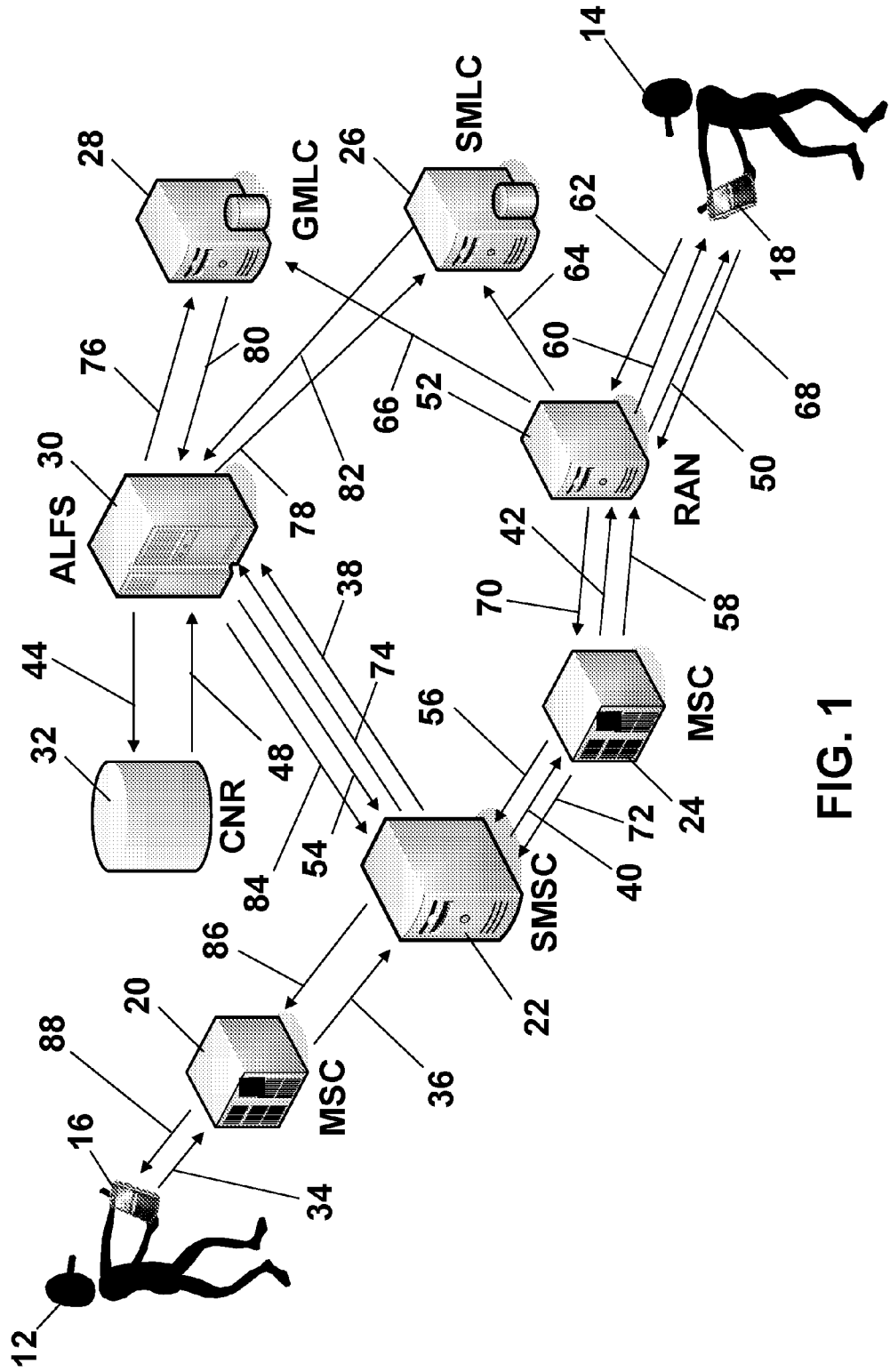

FIG. 1

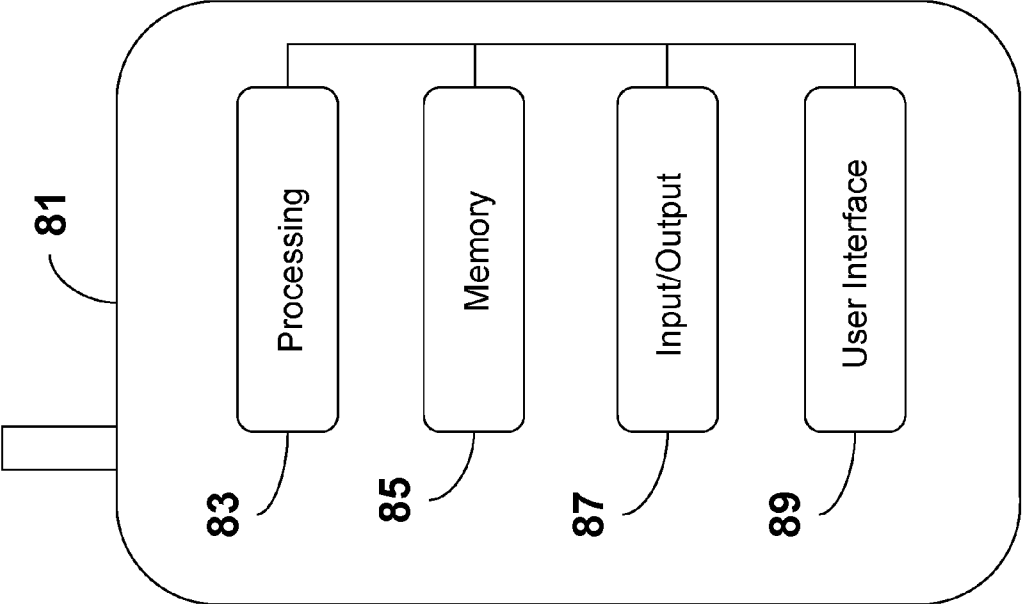

FIG. 2

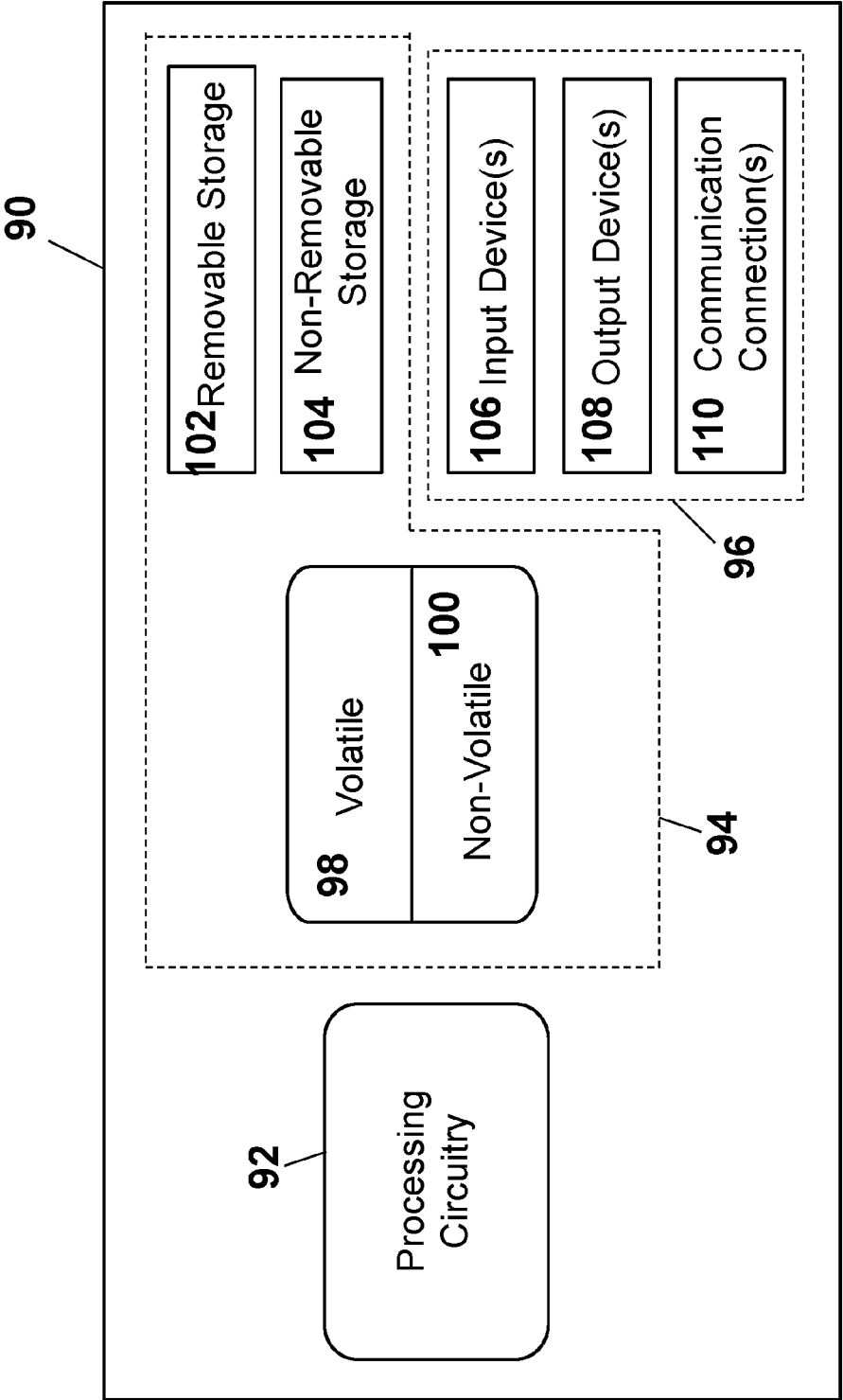

FIG. 3

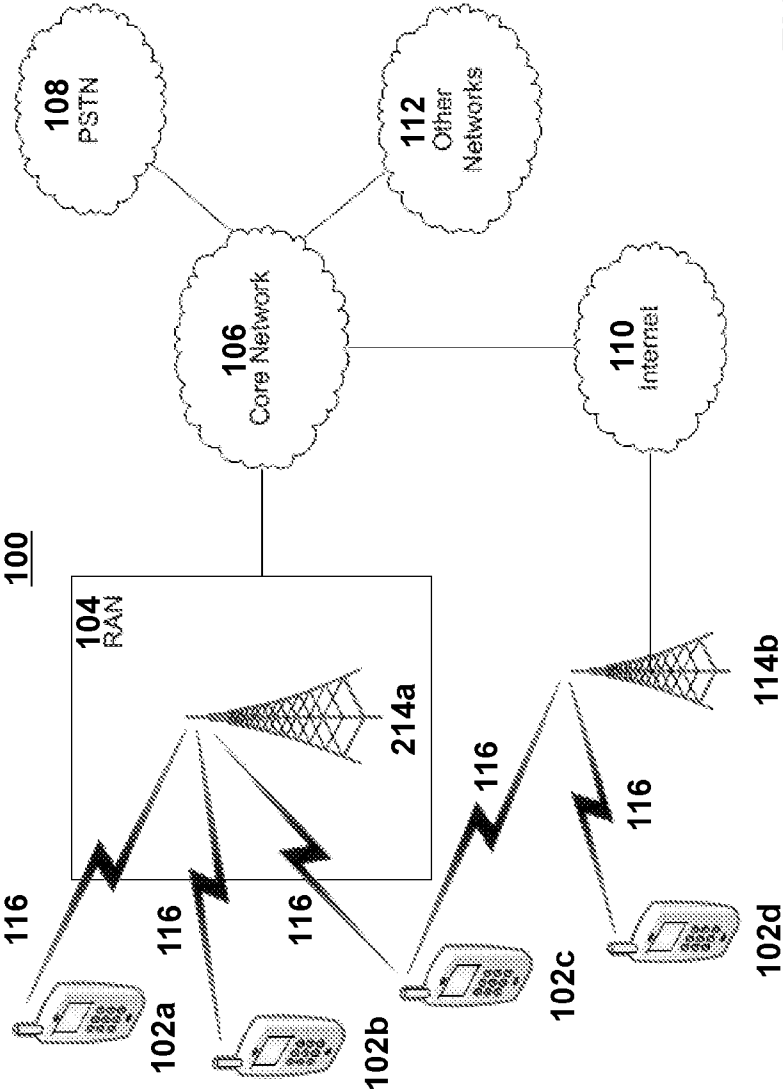

FIG. 4

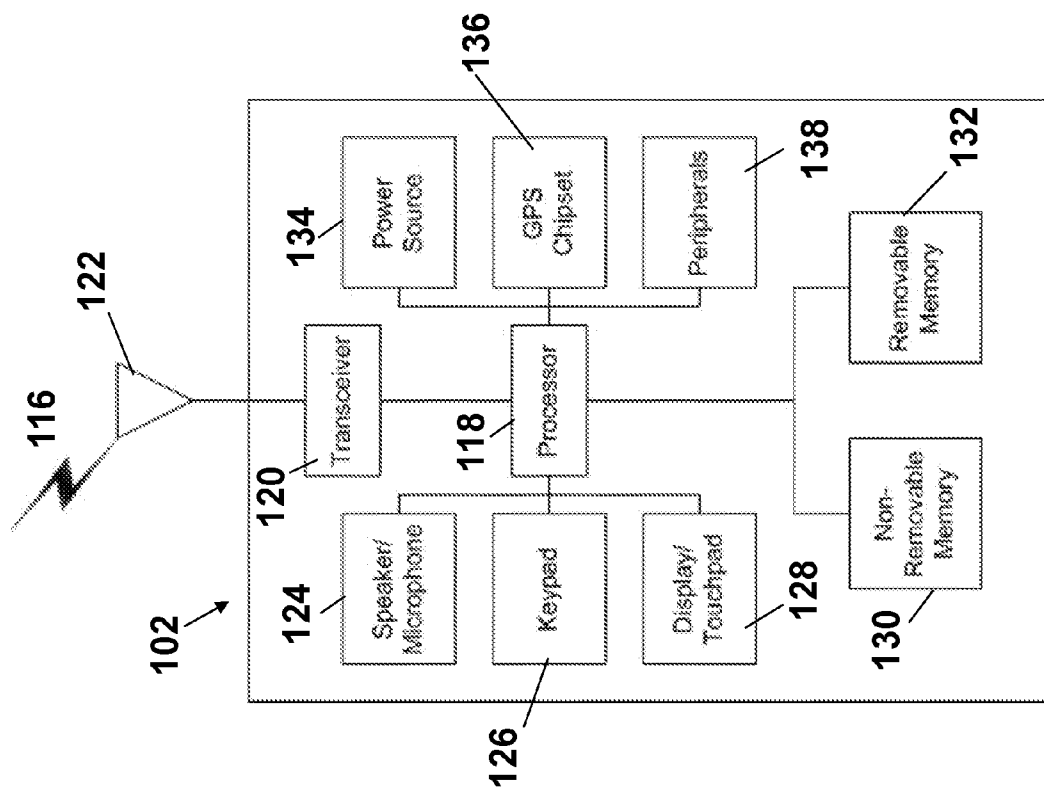

FIG. 5

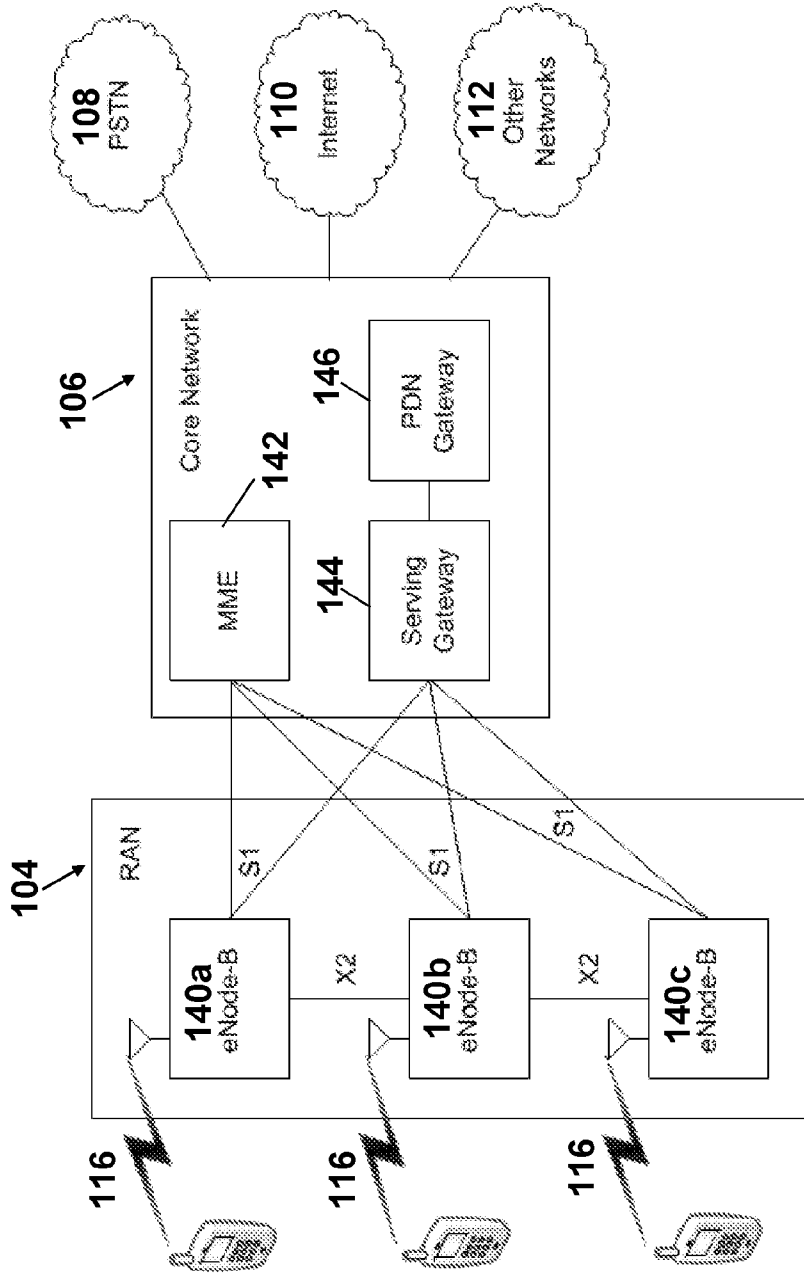

FIG. 6

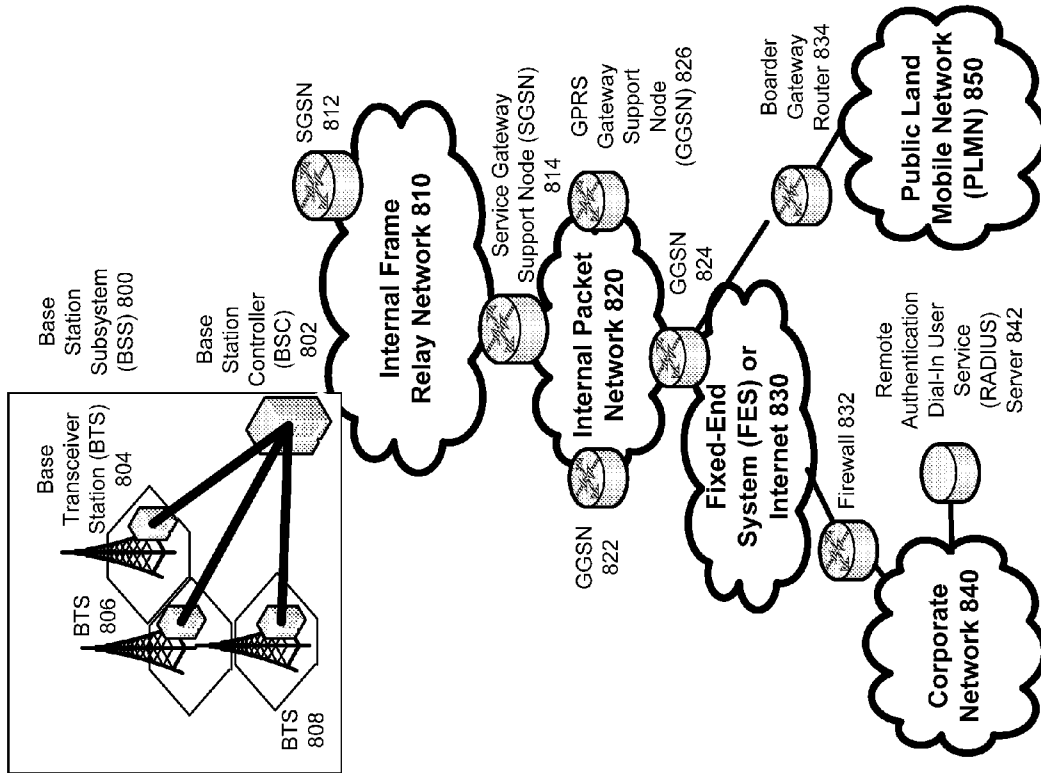

FIG. 7

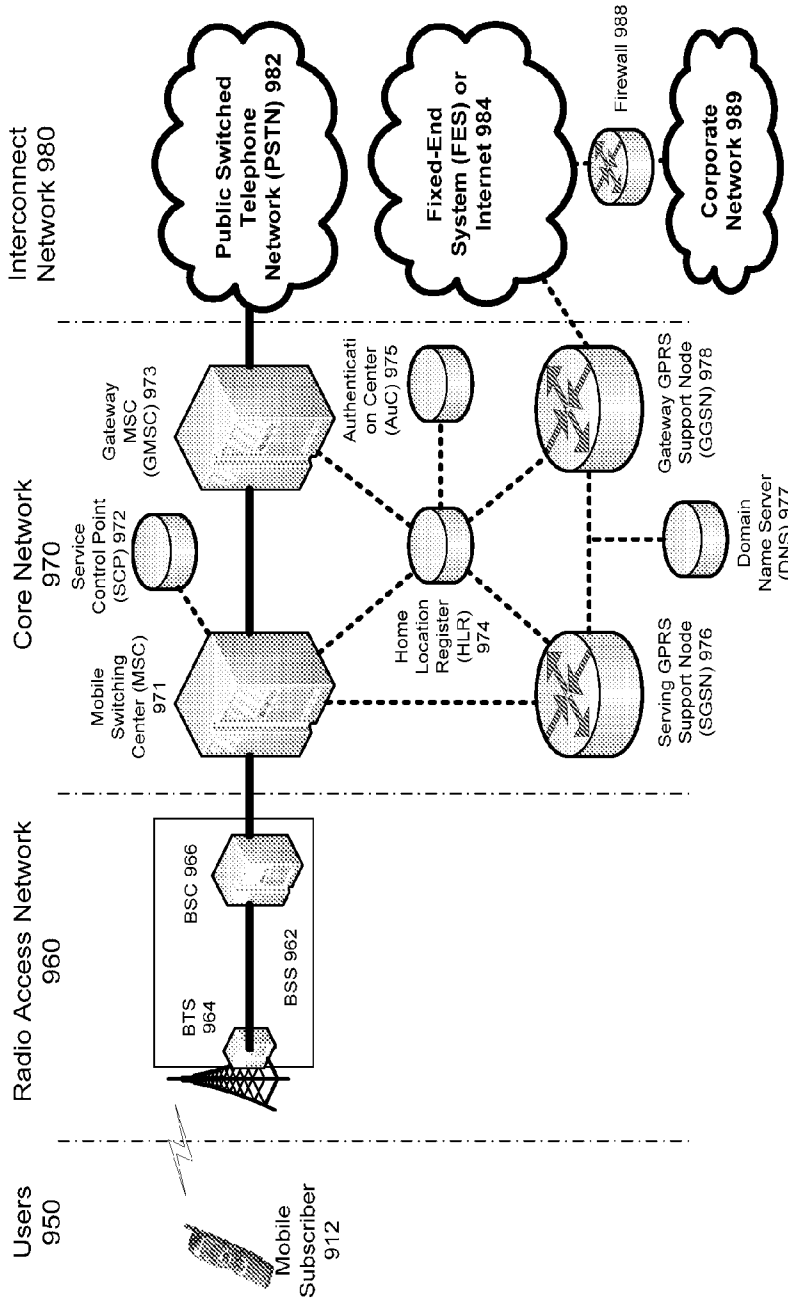

FIG. 8

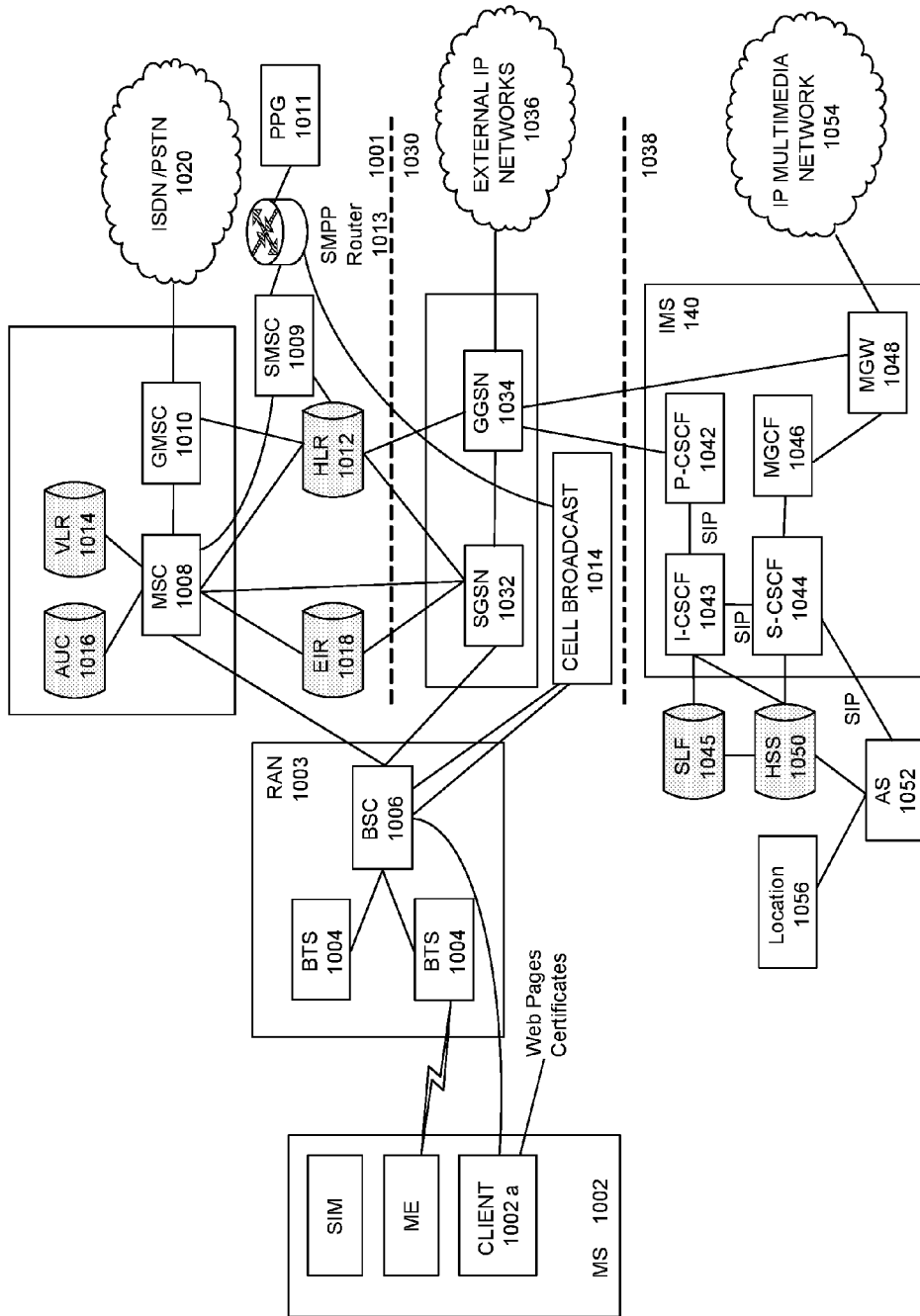
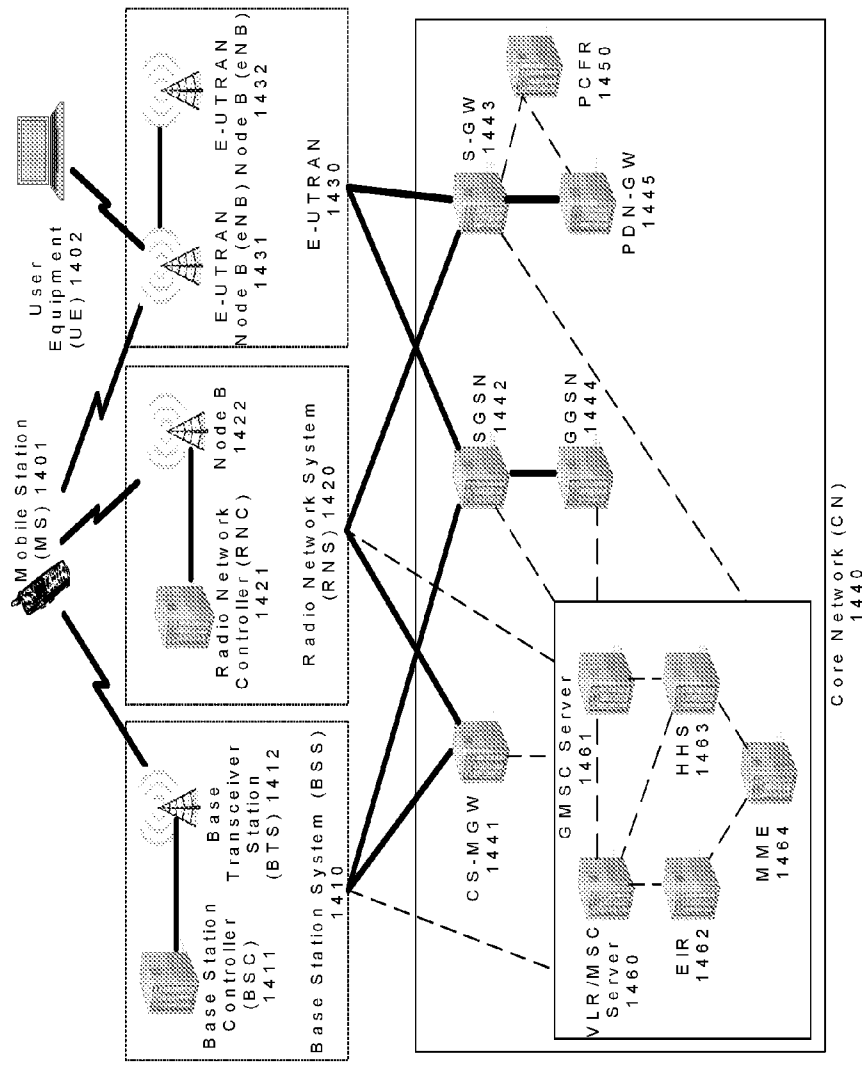

FIG. 9



NOTE Solid Lines represent user traffic signals while dashed lines represent support signaling

FIG. 10

LOCATING A DEVICE VIA A TEXT MESSAGE

CROSS REFERENCE TO RELATED PATENT APPLICATIONS

[0001] This application is a continuation application of U.S. patent application Ser. No. 14/093,192, filed Nov. 29, 2013, which is incorporated herein by reference in its entirety.

TECHNICAL FIELD

[0002] The technical field generally relates to communication, and more specifically to locating a device via a text message.

BACKGROUND

[0003] It is not uncommon for a person to want to know the location of another person. The reasons for wanting to know such information are numerous. For example, a parent may want to know the location of a child. A person may want to know the location of his or her spouse. A teacher may want to know the location of his or her students on a field trip.

[0004] The desire to know another's location could become urgent during an emergency situation. For example, when an event occurs, such as an earthquake, storm, etc., a person may want to know if a family member is within proximity of the event.

SUMMARY

[0005] The location of a device may be determined via a text message. In an example embodiment, a first device may receive a location of a second device simply by sending a text message to the second device. The text message may comprise a number associated with the second device (e.g., phone number of the second device, mobile subsection identification number—MSIN of the second device, etc.) and a predetermined (location) code. The text message may comprise a message for an intended recipient. A communication network may intercept the text message. The communication network, upon receipt of the text message, may analyze contents of the text message. If the text message comprises a message for an intended recipient, the communication network may parse the text message, and forward the message for the intended recipient to the intended recipient. The communication network may determine if the first device is authorized to receive the location of the second device. Upon a determination that the first device is authorized to receive the location of the second device, the network may determine the location of the second device via any of various techniques. In an example technique, the network may determine a recent location of the second device via registration with the network. In another example embodiment, the network may provide a request to the second device to determine its location, via global positioning system (GPS) equipment on the second device, or the like. The second device, in response, may determine its location via autonomous GPS and send an indication of its location to the network. In another example embodiment, the network may determine the location of the second device via assisted GPS (A-GPS) or the like. Upon determining the

location of the second device, the network may provide an indication of the location of the second device to the first device.

BRIEF DESCRIPTION OF THE DRAWINGS

[0006] Aspects of determining a location of a device via a text message are described more fully herein with reference to the accompanying drawings, in which example embodiments are shown. In the following description, for purposes of explanation, numerous specific details are set forth in order to provide an understanding of the various embodiments. However, the instant disclosure may be embodied in many different forms and should not be construed as limited to the example embodiments set forth herein. Like numbers refer to like elements throughout.

[0007] FIG. 1 illustrates an example system and method for determining a location of a device via a text message.

[0008] FIG. 2 is a block diagram of an example device that may be utilized to facilitate locating a device via a text message.

[0009] FIG. 3 is a block diagram of another example device that may be utilized to facilitate locating a device via a text message.

[0010] FIG. 4 is a diagram of an example communications system in which locating a device via a text message may be implemented.

[0011] FIG. 5 is a system diagram of an example WTRU which may be utilized for locating a device via a text message.

[0012] FIG. 6 is a system diagram of an example RAN and an example core network.

[0013] FIG. 7 depicts an overall block diagram of an example packet-based mobile cellular network environment, such as a GPRS network, within which locating a device via a text message may be implemented.

[0014] FIG. 8 illustrates an architecture of a typical GPRS network within which locating a device via a text message may be implemented.

[0015] FIG. 9 illustrates an example block diagram view of a GSM/GPRS/IP multimedia network architecture within which locating a device via a text message may be implemented.

[0016] FIG. 10 illustrates a PLMN block diagram view of an example architecture within which locating a device via a text message may be implemented.

DETAILED DESCRIPTION OF ILLUSTRATIVE EMBODIMENTS

[0017] FIG. 1 illustrates an example system and method for determining a location of a device via a text message. As depicted in FIG. 1, user 12 may want to determine/know the location of user 14. From the perspective of user 12, user 12 may generate and send a text message to user 14, and in response, receive an indication of the location of user 14. The text message may be generated via any appropriate manner. For example, user 12 may enter the communication address (e.g., phone number, email address, or the like) of device 18 and enter a predetermined code (also referred to herein as location code) as text into the text message. The location code may indicate that a location of the recipient device (e.g., device 18) is to be determined. The text message may comprise a message for user 14. In an example embodiment, user 12 may start an application, or the like, on

device 16 that previously has been installed on device 16. The application may provide user 12, via a user interface, or the like, on device 16, the option to initiate a text based session for determining a location of an intended recipient (device associated with the intended recipient).

[0018] In an example configuration, a text based session may automatically be initiated via preferences in a profile of user 12. For example, based on user's 12 profile and a configuration of device 16, user 12 may be able to select user 14 from a contact list, speak the name (or appropriate moniker) of user 14, or the like, or any appropriate combination thereof. To indicate that a location of user 14 is to be determined, user 12 may tap (select) an icon (e.g., map, compass, weather vane, etc.) on device 16, may touch a designated portion of device 16, or any appropriate combination thereof. Selecting the icon may automatically generate the location code and incorporate the location code into the text message. In an example embodiment, user 12 may initiate generation of the text message and/or initiate generation of the location code via a voice command. For example, user 12 may say the term "locate," "find," "where," or the like, followed by a name, moniker, or the like, of the person of interest, to initiate generation of the location code and incorporation of the code into the text message. In this example embodiment, the location code and a destination address associated with the person of interest may automatically be generated.

[0019] In an example embodiment, user 12 may initiate generation of the text message and/or initiate generation of the location code via moving device 16 in a predetermined manner. For example, user 12 may shake device 16, or the like, to initiate generation of the location code and incorporation of the code into the text message. In an example embodiment, user 12 may initiate generation of the text message and/or initiate generation of the location code via a predetermined gesture. The gesture may comprise any appropriate gesture, such as, for example, waving a hand proximate to device 16, waving a hand proximate to a designated portion of device 16 (e.g., front of device, back of device, side of device, top of device, bottom of device, etc.).

[0020] A person may be interested in determining/knowing the location of another person only if the other person is within a specific region. For example, if a storm is approaching a town (e.g., Redmond, Wash.), a person may be interested in knowing if a family member is within a region proximate to the town. Accordingly, referring again to FIG. 1, in an example embodiment, user 12 may select, via device 16, a region of interest, and may receive an indication of a location of a person (e.g., user 14) only if the person/user 14 is within the region of interest. The region may comprise any appropriate region, such as, for example, a two-dimensional region, a three-dimensional region, a geographic region, a building, a town, a moving region (e.g., vehicle), or any appropriate combination thereof. A region of interest may be selected in any appropriate manner. For example, a region may be selected by tracing a polygon (e.g., with a finger, digit, stylus, etc.) around a region as depicted on a map or the like. A region may be selected by tapping (selecting) a portion of a map, an icon, or the like. A region may be selected by providing a spoken description of the region (e.g., Pentagon, Redmond Town Center, New York City, Seattle library, specific ball park, etc.).

[0021] Upon initiating the text based session, the text message may be provided, by device 16, at step 34. In an example embodiment, the text message may be provided, at step 34, to mobile switching center (MSC) 20. MSC 20 may provide the text message, at step 36, to short message service center (SMSC) 22. SMSC 22 may analyze the text message and determine the contents of the text message. If it is determined that the text message comprises a message for the intended recipient (e.g., user 14), SMSC 22 may parse the text message, or the like, in order to forward, via MSC 24 and radio access network (RAN) 52, at step 40, step 42, and step 50, the appropriately formatted message for the intended recipient (e.g., user 14) to the intended recipient (e.g., user 14). Upon analyzing the text message (received at step 36), SMSC 22 may determine that the text message contains the predetermined location code. Upon detecting the predetermined location code in the text message, SMSC 22, may provide the text message, at step 38, to automatic location function server (ALFS) 30. In an example embodiment, if the text message (received at step 36) does not comprise a message for an intended recipient, and does comprise the location code, rather than forwarding the text message to user 14, SMSC 22 may provide the text message to automatic location function server (ALFS) 30, at step 38.

[0022] The location code may comprise any appropriate code, message, indicator, or the like, that may indicate that a location is being requested. In an example embodiment, the location code may comprise a specific text message. In an example embodiment, the specific text message may comprise five digits or characters. The location code may be a static code that never changes, a dynamic code that may be updated, or any appropriate combination thereof (e.g., a portion of the code may be static and a portion of the code may be dynamic). In an example embodiment, the location code may be incorporated into metadata of the text message, the location code may be incorporated into text of the text message, the location code may be incorporated into the body of the text message, the location code may be incorporated into a subject line of the text message, the location code may be incorporated into an attachment of the text message, the location code may comprise text, the location code may comprise a graphic, the location code may comprise an image, the location code may comprise multimedia, or any appropriate combination thereof.

[0023] ALFS 30, responsive to receiving the text message (received at step 38), may analyze the message to determine the provider (sender) of the message (e.g., user 12 via device 16), the person of interest (e.g., user 14), and to further analyze the location code. The location code may be analyzed to determine if the location code is valid.

[0024] It may be determined if user 12 is authorized to receive an indication of the location of user 14. This authorization may be determined by analyzing a user profile of user 12, by analyzing a user profile of user 14, or any appropriate combination thereof. Accordingly, in an example embodiment, ALFS 30 may determine if the provider of the text message (e.g., user 12) is authorized to receive an indication of the location of the person of interest (e.g., user 14). ALFS 30 may query, at step 44, consolidated network repository (CNR) 32 for information from a profile of the provider of the text message (e.g., user's 12 profile). CNR 32 may comprise any appropriate repository, processor, server, apparatus, or the like. In an example embodiment, CNR 32 may comprise a combination of a home

location register (HLR) and a home subscriber server (HSS). CNR 32 may comprise a user profile for user 12. CNR 32 may respond to the query at step 48.

[0025] In an example embodiment, ALFS 30 may query CNR 32 for an indication as to whether user 12 is authorized to receive an indication of the location of user 14. CNR 32 may retrieve the profile of user 12, and upon analysis thereof, determine whether user 12 is authorized to receive an indication of the location of user 14. And, at step 48, CNR 32 may provide to ALFS 30, the indication as to whether user 12 is authorized to receive an indication of the location of user 14.

[0026] In an example embodiment, ALFS 30 may query, at step 44, CNR 32 for information from the profile of user 12. CNR 32 may retrieve the profile information and, at step 48, provide, at step 48, the profile information to ALFS 30. Responsive to receiving the profile information, ALFS 30 may analyze the received profile information to determine whether user 12 is authorized to receive an indication of the location of user 14.

[0027] In an example embodiment, ALFS 30 may determine if the provider of the text message (e.g., user 12) is authorized to receive an indication of the location of the person of interest (e.g., user 14). ALFS may query, at step 44, consolidated network repository (CNR) 32 for information from a profile of the person of interest (e.g., user's 14 profile). In an example embodiment, ALFS 30 may query CNR 32 for an indication as to whether user 12 is authorized to receive an indication of the location of user 14. CNR 32 may retrieve the profile of user 14, and upon analysis thereof, determine whether user 12 is authorized to receive an indication of the location of user 14. And, at step 48, CNR 32 may provide to ALFS 30, the indication as to whether user 12 is authorized to receive an indication of the location of user 14.

[0028] In an example embodiment, ALFS 30 may query, at step 44, CNR 32 for information from the profile of user 14. CNR 32 may retrieve the profile information and, at step 48, provide, at step 48, the profile information to ALFS 30. Responsive to receiving the profile information, ALFS 30 may analyze the received profile information to determine whether user 12 is authorized to receive an indication of the location of user 14.

[0029] Upon a determination that the location code is valid and that user 12 is authorized to receive an indication of the location of user 14, ALFS 30 may provide a message to device 18, informing device 18 that its location is being determined, requesting device 18 to update its location information, or any appropriate combination thereof. In an example embodiment, this message may be sent to device 18 from ALFS 30 via SMSC 22, MSC 24, and RAN 52, at step 54, step 56, step 58, and step 60. Responsive to receiving the message (received by device 18 at step 60), may autonomously determine its location. For example, device 18 may determine its location via autonomous GPS and send an indication of its location to the gateway mobile location center (GMLC) 28 and/or serving mobile location center (SMLC) 26, at step 62, step 64, and/or step 66. Device 18 may send an acknowledgment message to ALFS 30 indicating that the location of device 18 has been determined/updated. In an example embodiment, the acknowledgement message may comprise an indication of the location of the device 18, the acknowledgement message may comprise an indication that the location of the device 18 has been stored

in GMLC 28 and/or SMLC 26, or any appropriate combination thereof. Device 18 may provide the acknowledgment message to ALFS 30 via RAN 52, MSC 24, SMSC 22, at step 68, step 70, step 72, and step 74.

[0030] Responsive to receiving the acknowledgement message at step 74, ALFS 30 may query GMLC 28 at step 76, may query SMLC 26 at step 78, or any appropriate combination thereof, to obtain an indication of the location of device 18. GMLC 28 may respond to the query with an indication of the location of device 18 at step 80, SMLC 26 may respond to the query with an indication of the location of device 18 at step 82, or any appropriate combination thereof.

[0031] In an example embodiment, if device 18 is not capable of determining its location (e.g., does not comprise GPS receiver, etc.), device 18 may acknowledge receipt of the message received at step 60, wherein the acknowledgement may include an indication that device 18 is incapable of determining its location. Upon receipt of the acknowledgement message, any appropriate entity in the network may initiate a determination of the location of device 18. The location may be determined in any appropriate manner, such as, for example, via any type of location determination system including, the Global Positioning System (GPS), assisted GPS (A-GPS), time difference of arrival calculations, configured constant location (in the case of non-moving devices), any combination thereof, or any other appropriate means.

[0032] In an example embodiment, if device 18 is not capable of determining its location, device 18 may provide the acknowledgment message to ALFS 30 via RAN 52, MSC 24, SMSC 22, at step 68, step 70, step 72, and step 74. Responsive to receiving the acknowledgement message at step 74, ALFS 30 may initiate a determination of the location of device 18 as described above.

[0033] Responsive to receiving an indication of the location of device 18, ALFS 30 may provide the indication of the location of device 18 to device 16. In an example embodiment, the ALFS 30 may provide the indication of the location of device 18 to device 16 via SMSC 22 and MSC 20 at step 84, step 86, and step 88.

[0034] Device 16 may render the indication of the location of device 14 in any appropriate manner. For example, the location of device 18 may be rendered visually, audibly, haptically (e.g., vibration), or any appropriate combination thereof. In an example embodiment, the location of device may be rendered on a map or the like. The location of device 16 also may be rendered on the map. The location of device 16 and the location of device 18 may be maintained and tracked, and rendered on the map, thus indicating the relative spatial relationship (e.g., distance and direction) between device 16 and device 18.

[0035] FIG. 2 is a block diagram of an example device 81 that may be utilized to facilitate locating a device via a text message as described herein. The device 81 may comprise and/or be incorporated into any appropriate device, examples of which may include a device 16, device 18, a mobile device, a mobile communications device, a cellular phone, a portable computing device, such as a laptop, a personal digital assistant ("PDA"), a portable phone (e.g., a cell phone or the like, a smart phone, a video phone), a portable email device, a portable gaming device, a TV, a DVD player, portable media player, (e.g., a portable music player, such as an MP3 player, a Walkman, etc.), a portable

navigation device (e.g., GPS compatible device, A-GPS compatible device, etc.), or a combination thereof. The device **81** can include devices that are not typically thought of as portable, such as, for example, a public computing device, a navigation device installed in-vehicle, a set top box, or the like. The mobile device **81** can include non-conventional computing devices, such as, for example, a kitchen appliance, a motor vehicle control (e.g., steering wheel), etc., or the like. As evident from the herein description, a device, a communications device, or a mobile device is not to be construed as software per se.

[0036] The device **81** may include any appropriate device, mechanism, software, and/or hardware for locating a device via a text message as described herein. In an example embodiment, the ability to locate a device via a text message is a feature of the device **81** that can be turned on and off. Thus, in an example embodiment, an owner and/or user of the device **81** may opt-in or opt-out of this capability.

[0037] In an example embodiment, the device **81** may comprise a processor and memory coupled to the processor. The memory may comprise executable instructions that when executed by the processor cause the processor to effectuate operations associated with locating a device via a text message as described herein.

[0038] In an example configuration, the device **81** may comprise a processing portion **83**, a memory portion **85**, an input/output portion **87**, and a user interface (UI) portion **89**. Each portion of the device **81** may comprise circuitry for performing functions associated with each respective portion. Thus, each portion may comprise hardware, or a combination of hardware and software. Accordingly, each portion of the device **81** is not to be construed as software per se. It is emphasized that the block diagram depiction of device **81** is exemplary and not intended to imply a specific implementation and/or configuration. For example, in an example configuration, the device **81** may comprise a cellular communications technology and the processing portion **83** and/or the memory portion **85** may be implemented, in part or in total, on a subscriber identity module (SIM) of the device **81**. In another example configuration, the device **81** may comprise a laptop computer. The laptop computer may include a SIM, and various portions of the processing portion **83** and/or the memory portion **85** may be implemented on the SIM, on the laptop other than the SIM, or any combination thereof.

[0039] The processing portion **83**, memory portion **85**, and input/output portion **87** may be coupled together to allow communications therebetween. In various embodiments, the input/output portion **87** may comprise a receiver of the device **81**, a transmitter of the device **81**, or a combination thereof. The input/output portion **87** may be capable of receiving and/or providing information pertaining to discovering, negotiating, sharing, and/or exchanging information and/or capabilities as described herein. In various configurations, the input/output portion **87** may receive and/or provide information via any appropriate means, such as, for example, optical means (e.g., infrared), electromagnetic means (e.g., RF, WI-FI, BLUETOOTH, ZIGBEE, etc.), acoustic means (e.g., speaker, microphone, ultrasonic receiver, ultrasonic transmitter), or a combination thereof.

[0040] The processing portion **83** may be capable of performing functions pertaining to locating a device via a text message as described herein. In a basic configuration, the device **81** may include at least one memory portion **85**.

The memory portion **85** may comprise a storage medium having a concrete, tangible, physical structure. Thus, the memory portion **85**, as well as any computer-readable storage medium described herein, is not to be construed as a transient signal per se. Further, the memory portion **85**, as well as any computer-readable storage medium described herein, is not to be construed as a propagating signal per se. The memory portion **85**, as well as any computer-readable storage medium described herein, is to be construed as an article of manufacture. The memory portion **85** may store any information utilized in conjunction with locating a device via a text message as described herein. Depending upon the exact configuration and type of processor, the memory portion **85** may be volatile (such as some types of RAM), non-volatile (such as ROM, flash memory, etc.), or a combination thereof. The mobile device **81** may include additional storage (e.g., removable storage and/or non-removable storage) including, but not limited to, tape, flash memory, smart cards, CD-ROM, digital versatile disks (DVD) or other optical storage, magnetic cassettes, magnetic tape, magnetic disk storage or other magnetic storage devices, universal serial bus (USB) compatible memory, or any other medium which can be used to store information and which can be accessed by the mobile device **81**.

[0041] The device **81** also may contain a user interface (UI) portion **89** allowing a user to communicate with the device **81**. The UI portion **89** may be capable of rendering any information utilized in conjunction with locating a device via a text message as described herein. The UI portion **89** may provide the ability to control the device **81**, via, for example, buttons, soft keys, voice actuated controls, a touch screen, movement of the mobile device **81**, visual cues (e.g., moving a hand in front of a camera on the mobile device **81**), or the like. The UI portion **89** may provide visual information (e.g., via a display), audio information (e.g., via speaker), mechanically (e.g., via a vibrating mechanism), or a combination thereof. In various configurations, the UI portion **89** may comprise a display, a touch screen, a keyboard, an accelerometer, a motion detector, a speaker, a microphone, a camera, a tilt sensor, or any combination thereof. The UI portion **89** may comprise means for inputting biometric information, such as, for example, fingerprint information, retinal information, voice information, and/or facial characteristic information.

[0042] The UI portion **89** may include a display for displaying multimedia such as, for example, application graphical user interfaces (GUIs), text, images, video, telephony functions such as Caller ID data, setup functions, menus, music, metadata, messages, wallpaper, graphics, Internet content, device status, preferences settings, map and location data, routes and other directions, points of interest (POI), and the like.

[0043] In some embodiments, the UI portion may comprise a user interface (UI) application. The UI application may interface with a client or operating system (OS) to, for example, facilitate user interaction with device functionality and data. The UI application may aid a user in entering message content, viewing received messages, answering/initiating calls, entering/deleting data, entering and setting user IDs and passwords, configuring settings, manipulating content and/or settings, interacting with other applications, or the like, and may aid the user in inputting selections

associated with discovering, negotiating, sharing, and/or exchanging information and/or capabilities as described herein.

[0044] FIG. 3 is a block diagram of another example device 90 that may be utilized to locating a device via a text message as described herein. The device 90 may comprise hardware or a combination of hardware and software. In an example embodiment, the device 90 may comprise a network entity and when used in conjunction with a network, the functionality needed to facilitate locating a device via a text message as described herein may reside in any one or combination of devices. The device 90 depicted in FIG. 3 may represent any appropriate network entity, or combination of network entities, such as, for example, a component or various components of a cellular broadcast system wireless network, a processor, a server, a gateway, a node, a MSC, a SMSC, an ALFS, a GMLC, a RAN, a SMLC, MSC 20, SMSC 22, MSC 24, RAN 52, SMLC 26, GMLC 28, ALFS 30, or any appropriate combination thereof. It is emphasized that the block diagram depicted in FIG. 3 is exemplary and not intended to imply a specific implementation or configuration. Thus, the device 90 may be implemented in a single device or multiple devices (e.g., single server or multiple servers, single gateway or multiple gateways, etc.). Multiple network entities may be distributed or centrally located. Multiple network entities may communicate wirelessly, via hard wire, or any appropriate combination thereof.

[0045] In an example embodiment, the device 90 may comprise a processor and memory coupled to the processor. The memory may comprise executable instructions that when executed by the processor cause the processor to effectuate operations associated with locating a device via a text message as described herein. As evident from the herein description the device 90 is not to be construed as software per se.

[0046] In an example configuration, the device 90 may comprise a processing portion 92, a memory portion 94, and an input/output portion 96. The processing portion 92, memory portion 94, and input/output portion 96 may be coupled together (coupling not shown in FIG. 3) to allow communications therebetween. Each portion of the device 90 may comprise circuitry for performing functions associated with each respective portion. Thus, each portion may comprise hardware, or a combination of hardware and software. Accordingly, each portion of the device 90 is not to be construed as software per se. The input/output portion 96 may be capable of receiving and/or providing information from/to a communications device and/or other network entities configured for locating a device via a text message as described herein. For example, the input/output portion 96 may include a wireless communications (e.g., 2.5G/3G/4G/GPS) card. The input/output portion 96 may be capable of receiving and/or sending video information, audio information, control information, image information, data, or any combination thereof. In an example embodiment, the input/output portion 96 may be capable of receiving and/or sending information to determine a location of the device 90 and/or the communications device 90. In an example configuration, the input/output portion 96 may comprise a GPS receiver. In an example configuration, the device 90 may determine its own geographical location and/or the geographical location of a communications device through any type of location determination system including, for

example, the Global Positioning System (GPS), assisted GPS (A-GPS), time difference of arrival calculations, configured constant location (in the case of non-moving devices), any combination thereof, or any other appropriate means. In various configurations, the input/output portion 96 may receive and/or provide information via any appropriate means, such as, for example, optical means (e.g., infrared), electromagnetic means (e.g., RF, WI-FI, BLUETOOTH, ZIGBEE, etc.), acoustic means (e.g., speaker, microphone, ultrasonic receiver, ultrasonic transmitter), or a combination thereof. In an example configuration, the input/output portion may comprise a WIFI finder, a two way GPS chipset or equivalent, or the like, or a combination thereof.

[0047] The processing portion 92 may be capable of performing functions associated with locating a device via a text message as described herein. For example, the processing portion 92 may be capable of, in conjunction with any other portion of the device 90, installing an application for locating a device via a text message as described herein.

[0048] In a basic configuration, the device 90 may include at least one memory portion 94. The memory portion 94 may comprise a storage medium having a concrete, tangible, physical structure. Thus, the memory portion 94, as well as any computer-readable storage medium described herein, is not to be construed as a transient signal per se. The memory portion 94, as well as any computer-readable storage medium described herein, is not to be construed as a propagating signal per se. The memory portion 94, as well as any computer-readable storage medium described herein, is to be construed as an article of manufacture. The memory portion 94 may store any information utilized in conjunction with locating a device via a text message as described herein. Depending upon the exact configuration and type of processor, the memory portion 94 may be volatile 98 (such as some types of RAM), non-volatile 100 (such as ROM, flash memory, etc.), or a combination thereof. The device 90 may include additional storage (e.g., removable storage 102 and/or non-removable storage 104) including, for example, tape, flash memory, smart cards, CD-ROM, digital versatile disks (DVD) or other optical storage, magnetic cassettes, magnetic tape, magnetic disk storage or other magnetic storage devices, universal serial bus (USB) compatible memory, or any other medium which can be used to store information and which can be accessed by the device 90.

[0049] The device 90 also may contain communications connection(s) 110 that allow the device 90 to communicate with other devices, network entities, or the like. A communications connection(s) may comprise communication media. Communication media typically embody computer readable instructions, data structures, program modules or other data in a modulated data signal such as a carrier wave or other transport mechanism and includes any information delivery media. By way of example, and not limitation, communication media may include wired media such as a wired network or direct-wired connection, and wireless media such as acoustic, RF, infrared, and other wireless media. The term computer readable media as used herein includes both storage media and communication media. The device 90 also may include input device(s) 106 such as keyboard, mouse, pen, voice input device, touch input device, etc. Output device(s) 108 such as a display, speakers, printer, etc. also may be included.

[0050] A device, or devices, as described herein may be part of and/or communicate with various wireless communications networks. Some of which are described below.

[0051] FIG. 4 is a diagram of an example communications system in which locating a device via a text message as described herein may be implemented. The communications system 100 may be a multiple access system that provides content, such as voice, data, video, messaging, broadcast, etc., to multiple wireless users. The communications system 100 may enable multiple wireless users to access such content through the sharing of system resources, including wireless bandwidth. For example, the communications systems 100 may employ one or more channel access methods, such as code division multiple access (CDMA), time division multiple access (TDMA), frequency division multiple access (FDMA), orthogonal FDMA (OFDMA), single-carrier FDMA (SC-FDMA), and the like. A communications system such as that shown in FIG. 4 may also be referred to herein as a network.

[0052] As shown in FIG. 4, the communications system 100 may include wireless transmit/receive units (WTRUs) 102a, 102b, 102c, 102d, a radio access network (RAN) 104, a core network 106, a public switched telephone network (PSTN) 108, the Internet 110, and other networks 112, though it will be appreciated that the disclosed embodiments contemplate any number of WTRUs, base stations, networks, and/or network elements. Each of the WTRUs 102a, 102b, 102c, 102d may be any type of device configured to operate and/or communicate in a wireless environment. For example, a WTRU may comprise network entity 12, network entity 26, a UE, or the like, or any combination thereof. By way of example, the WTRUs 102a, 102b, 102c, 102d may be configured to transmit and/or receive wireless signals and may include user equipment (UE), a mobile station, a mobile device, a fixed or mobile subscriber unit, a pager, a cellular telephone, a personal digital assistant (PDA), a smartphone, a laptop, a netbook, a personal computer, a wireless sensor, consumer electronics, and the like.

[0053] The communications systems 100 may also include a base station 114a and a base station 114b. Each of the base stations 114a, 114b may be any type of device configured to wirelessly interface with at least one of the WTRUs 102a, 102b, 102c, 102d to facilitate access to one or more communication networks, such as the core network 106, the Internet 110, and/or the networks 112. By way of example, the base stations 114a, 114b may be a base transceiver station (BTS), a Node-B, an eNode B, a Home Node B, a Home eNode B, a site controller, an access point (AP), a wireless router, and the like. While the base stations 114a, 114b are each depicted as a single element, it will be appreciated that the base stations 114a, 114b may include any number of interconnected base stations and/or network elements.

[0054] The base station 114a may be part of the RAN 104, which may also include other base stations and/or network elements (not shown), such as a base station controller (BSC), a radio network controller (RNC), relay nodes, etc. The base station 114a and/or the base station 114b may be configured to transmit and/or receive wireless signals within a particular geographic region, which may be referred to as a cell (not shown). The cell may further be divided into cell sectors. For example, the cell associated with the base station 114a may be divided into three sectors. Thus, in an embodiment, the base station 114a may include three trans-

ceivers, i.e., one for each sector of the cell. In another embodiment, the base station 114a may employ multiple-input multiple output (MIMO) technology and, therefore, may utilize multiple transceivers for each sector of the cell.

[0055] The base stations 114a, 114b may communicate with one or more of the WTRUs 102a, 102b, 102c, 102d over an air interface 116, which may be any suitable wireless communication link (e.g., radio frequency (RF), microwave, infrared (IR), ultraviolet (UV), visible light, etc.). The air interface 116 may be established using any suitable radio access technology (RAT).

[0056] More specifically, as noted above, the communications system 100 may be a multiple access system and may employ one or more channel access schemes, such as CDMA, TDMA, FDMA, OFDMA, SC-FDMA, and the like. For example, the base station 114a in the RAN 104 and the WTRUs 102a, 102b, 102c may implement a radio technology such as Universal Mobile Telecommunications System (UMTS) Terrestrial Radio Access (UTRA) that may establish the air interface 116 using wideband CDMA (WCDMA). WCDMA may include communication protocols such as High-Speed Packet Access (HSPA) and/or Evolved HSPA (HSPA+). HSPA may include High-Speed Downlink Packet Access (HSDPA) and/or High-Speed Uplink Packet Access (HSUPA).

[0057] In another embodiment, the base station 114a and the WTRUs 102a, 102b, 102c may implement a radio technology such as Evolved UMTS Terrestrial Radio Access (E-UTRA), which may establish the air interface 116 using Long Term Evolution (LTE) and/or LTE-Advanced (LTE-A).

[0058] In other embodiments, the base station 114a and the WTRUs 102a, 102b, 102c may implement radio technologies such as IEEE 802.16 (i.e., Worldwide Interoperability for Microwave Access (WiMAX)), CDMA2000, CDMA2000 1x, CDMA2000 EV-DO, Interim Standard 2000 (IS-2000), Interim Standard 95 (IS-95), Interim Standard 856 (IS-856), Global System for Mobile communications (GSM), Enhanced Data rates for GSM Evolution (EDGE), GSM EDGE (GERAN), and the like.

[0059] The base station 114b in FIG. 4 may be a wireless router, Home Node B, Home eNode B, or access point, for example, and may utilize any suitable RAT for facilitating wireless connectivity in a localized area, such as a place of business, a home, a vehicle, a campus, and the like. In one embodiment, the base station 114b and the WTRUs 102c, 102d may implement a radio technology such as IEEE 802.11 to establish a wireless local area network (WLAN). In another embodiment, the base station 114b and the WTRUs 102c, 102d may implement a radio technology such as IEEE 802.15 to establish a wireless personal area network (WPAN). In yet another embodiment, the base station 114b and the WTRUs 102c, 102d may utilize a cellular-based RAT (e.g., WCDMA, CDMA2000, GSM, LTE, LTE-A, etc.) to establish a picocell or femtocell. As shown in FIG. 4, the base station 114b may have a direct connection to the Internet 110. Thus, the base station 114b may not be required to access the Internet 110 via the core network 106.

[0060] The RAN 104 may be in communication with the core network 106, which may be any type of network configured to provide voice, data, applications, and/or voice over internet protocol (VoIP) services to one or more of the WTRUs 102a, 102b, 102c, 102d. For example, the core network 106 may provide call control, billing services,

mobile location-based services, pre-paid calling, Internet connectivity, video distribution, etc., and/or perform high-level security functions, such as user authentication. Although not shown in FIG. 4, it will be appreciated that the RAN 104 and/or the core network 106 may be in direct or indirect communication with other RANs that employ the same RAT as the RAN 104 or a different RAT. For example, in addition to being connected to the RAN 104, which may be utilizing an E-UTRA radio technology, the core network 106 may also be in communication with another RAN (not shown) employing a GSM radio technology.

[0061] The core network 106 may also serve as a gateway for the WTRUs 102a, 102b, 102c, 102d to access the PSTN 108, the Internet 110, and/or other networks 112. The PSTN 108 may include circuit-switched telephone networks that provide plain old telephone service (POTS). The Internet 110 may include a global system of interconnected computer networks and devices that use common communication protocols, such as the transmission control protocol (TCP), user datagram protocol (UDP) and the internet protocol (IP) in the TCP/IP internet protocol suite. The networks 112 may include wired or wireless communications networks owned and/or operated by other service providers. For example, the networks 112 may include another core network connected to one or more RANs, which may employ the same RAT as the RAN 104 or a different RAT.

[0062] Some or all of the WTRUs 102a, 102b, 102c, 102d in the communications system 100 may include multi-mode capabilities, i.e., the WTRUs 102a, 102b, 102c, 102d may include multiple transceivers for communicating with different wireless networks over different wireless links. For example, the WTRU 102c shown in FIG. 4 may be configured to communicate with the base station 114a, which may employ a cellular-based radio technology, and with the base station 114b, which may employ an IEEE 802 radio technology.

[0063] FIG. 5 is a system diagram of an example WTRU 102 which may be utilized to facilitate locating a device via a text message. As shown in FIG. 5, the WTRU 102 may include a processor 118, a transceiver 120, a transmit/receive element 122, a speaker/microphone 124, a keypad 126, a display/touchpad 128, non-removable memory 130, removable memory 132, a power source 134, a global positioning system (GPS) chipset 136, and other peripherals 138. It will be appreciated that the WTRU 102 may include any sub-combination of the foregoing elements while remaining consistent with an embodiment.

[0064] The processor 118 may be a general purpose processor, a special purpose processor, a conventional processor, a digital signal processor (DSP), a plurality of microprocessors, one or more microprocessors in association with a DSP core, a controller, a microcontroller, Application Specific Integrated Circuits (ASICs), Field Programmable Gate Array (FPGAs) circuits, any other type of integrated circuit (IC), a state machine, and the like. The processor 118 may perform signal coding, data processing, power control, input/output processing, and/or any other functionality that enables the WTRU 102 to operate in a wireless environment. The processor 118 may be coupled to the transceiver 120, which may be coupled to the transmit/receive element 122. While FIG. 8 depicts the processor 118 and the transceiver 120 as separate components, it will be appreciated that the processor 118 and the transceiver 120 may be integrated together in an electronic package or chip.

[0065] The transmit/receive element 122 may be configured to transmit signals to, or receive signals from, a base station (e.g., the base station 114a) over the air interface 116. For example, in one embodiment, the transmit/receive element 122 may be an antenna configured to transmit and/or receive RF signals. In another embodiment, the transmit/receive element 122 may be an emitter/detector configured to transmit and/or receive IR, UV, or visible light signals, for example. In yet another embodiment, the transmit/receive element 122 may be configured to transmit and receive both RF and light signals. It will be appreciated that the transmit/receive element 122 may be configured to transmit and/or receive any combination of wireless signals.

[0066] In addition, although the transmit/receive element 122 is depicted in FIG. 5 as a single element, the WTRU 102 may include any number of transmit/receive elements 122. More specifically, the WTRU 102 may employ MIMO technology. Thus, in one embodiment, the WTRU 102 may include two or more transmit/receive elements 122 (e.g., multiple antennas) for transmitting and receiving wireless signals over the air interface 116.

[0067] The transceiver 120 may be configured to modulate the signals that are to be transmitted by the transmit/receive element 122 and to demodulate the signals that are received by the transmit/receive element 122. As noted above, the WTRU 102 may have multi-mode capabilities. Thus, the transceiver 120 may include multiple transceivers for enabling the WTRU 102 to communicate via multiple RATs, such as UTRA and IEEE 802.11, for example.

[0068] The processor 118 of the WTRU 102 may be coupled to, and may receive user input data from, the speaker/microphone 124, the keypad 126, and/or the display/touchpad 128 (e.g., a liquid crystal display (LCD) display unit or organic light-emitting diode (OLED) display unit). The processor 118 may also output user data to the speaker/microphone 124, the keypad 126, and/or the display/touchpad 128. In addition, the processor 118 may access information from, and store data in, any type of suitable memory, such as the non-removable memory 130 and/or the removable memory 132. The non-removable memory 130 may include random-access memory (RAM), read-only memory (ROM), a hard disk, or any other type of memory storage device. The removable memory 132 may include a subscriber identity module (SIM) card, a memory stick, a secure digital (SD) memory card, and the like. In other embodiments, the processor 118 may access information from, and store data in, memory that is not physically located on the WTRU 102, such as on a server or a home computer (not shown).

[0069] The processor 118 may receive power from the power source 134, and may be configured to distribute and/or control the power to the other components in the WTRU 102. The power source 134 may be any suitable device for powering the WTRU 102. For example, the power source 134 may include one or more dry cell batteries (e.g., nickel-cadmium (NiCd), nickel-zinc (NiZn), nickel metal hydride (NiMH), lithium-ion (Li-ion), etc.), solar cells, fuel cells, and the like.

[0070] The processor 118 may also be coupled to the GPS chipset 136, which may be configured to provide location information (e.g., longitude and latitude) regarding the current location of the WTRU 102. In addition to, or in lieu of, the information from the GPS chipset 136, the WTRU 102 may receive location information over the air interface 116

from a base station (e.g., base stations **114a**, **114b**) and/or determine its location based on the timing of the signals being received from two or more nearby base stations. It will be appreciated that the WTRU **102** may acquire location information by way of any suitable location-determination method while remaining consistent with an embodiment.

[0071] The processor **118** may further be coupled to other peripherals **138**, which may include one or more software and/or hardware modules that provide additional features, functionality and/or wired or wireless connectivity. For example, the peripherals **138** may include an accelerometer, an e-compass, a satellite transceiver, a digital camera (for photographs or video), a universal serial bus (USB) port, a vibration device, a television transceiver, a hands free headset, a Bluetooth® module, a frequency modulated (FM) radio unit, a digital music player, a media player, a video game player module, an Internet browser, and the like.

[0072] FIG. 6 is an example system diagram of RAN **104** and a core network **106**. As noted above, the RAN **104** may employ an E-UTRA radio technology to communicate with the WTRUs **102a**, **102b**, and **102c** over the air interface **116**. The RAN **104** may also be in communication with the core network **106**.

[0073] The RAN **104** may include eNode-Bs **140a**, **140b**, **140c**, though it will be appreciated that the RAN **104** may include any number of eNode-Bs while remaining consistent with an embodiment. The eNode-Bs **140a**, **140b**, **140c** may each include one or more transceivers for communicating with the WTRUs **102a**, **102b**, **102c** over the air interface **116**. In one embodiment, the eNode-Bs **140a**, **140b**, **140c** may implement MIMO technology. Thus, the eNode-B **140a**, for example, may use multiple antennas to transmit wireless signals to, and receive wireless signals from, the WTRU **102a**.

[0074] Each of the eNode-Bs **140a**, **140b**, and **140c** may be associated with a particular cell (not shown) and may be configured to handle radio resource management decisions, handover decisions, scheduling of users in the uplink and/or downlink, and the like. As shown in FIG. 6, the eNode-Bs **140a**, **140b**, **140c** may communicate with one another over an X2 interface.

[0075] The core network **106** shown in FIG. 6 may include a mobility management gateway or entity (MME) **142**, a serving gateway **144**, and a packet data network (PDN) gateway **146**. While each of the foregoing elements are depicted as part of the core network **106**, it will be appreciated that any one of these elements may be owned and/or operated by an entity other than the core network operator.

[0076] The MME **142** may be connected to each of the eNode-Bs **140a**, **140b**, **140c** in the RAN **104** via an Si interface and may serve as a control node. For example, the MME **142** may be responsible for authenticating users of the WTRUs **102a**, **102b**, **102c**, bearer activation/deactivation, selecting a particular serving gateway during an initial attach of the WTRUs **102a**, **102b**, **102c**, and the like. The MME **142** may also provide a control plane function for switching between the RAN **104** and other RANs (not shown) that employ other radio technologies, such as GSM or WCDMA.

[0077] The serving gateway **144** may be connected to each of the eNode-Bs **140a**, **140b**, and **140c** in the RAN **104** via the Si interface. The serving gateway **144** may generally route and forward user data packets to/from the WTRUs **102a**, **102b**, **102c**. The serving gateway **144** may also perform other functions, such as anchoring user planes

during inter-eNode B handovers, triggering paging when downlink data is available for the WTRUs **102a**, **102b**, **102c**, managing and storing contexts of the WTRUs **102a**, **102b**, **102c**, and the like.

[0078] The serving gateway **144** may also be connected to the PDN gateway **146**, which may provide the WTRUs **102a**, **102b**, **102c** with access to packet-switched networks, such as the Internet **110**, to facilitate communications between the WTRUs **102a**, **102b**, **102c** and IP-enabled devices.

[0079] The core network **106** may facilitate communications with other networks. For example, the core network **106** may provide the WTRUs **102a**, **102b**, **102c** with access to circuit-switched networks, such as the PSTN **108**, to facilitate communications between the WTRUs **102a**, **102b**, **102c** and traditional land-line communications devices. For example, the core network **106** may include, or may communicate with, an IP gateway (e.g., an IP multimedia subsystem (IMS) server) that serves as an interface between the core network **106** and the PSTN **108**. In addition, the core network **106** may provide the WTRUs **102a**, **102b**, **102c** with access to the networks **112**, which may include other wired or wireless networks that are owned and/or operated by other service providers.

[0080] FIG. 7 depicts an overall block diagram of an example packet-based mobile cellular network environment, such as a GPRS network, within which locating a device via a text message as described herein may be implemented. In the example packet-based mobile cellular network environment shown in FIG. 7, there are a plurality of Base Station Subsystems (“BSS”) **800** (only one is shown), each of which comprises a Base Station Controller (“BSC”) **802** serving a plurality of Base Transceiver Stations (“BTS”) such as BTSs **804**, **806**, and **808**. BTSs **804**, **806**, **808**, etc. are the access points where users of packet-based mobile devices become connected to the wireless network. In example fashion, the packet traffic originating from user devices is transported via an over-the-air interface to a BTS **808**, and from the BTS **808** to the BSC **802**. Base station subsystems, such as BSS **800**, are a part of internal frame relay network **810** that can include Service GPRS Support Nodes (“SGSN”) such as SGSN **812** and **814**. Each SGSN is connected to an internal packet network **820** through which a SGSN **812**, **814**, etc. can route data packets to and from a plurality of gateway GPRS support nodes (GGSN) **822**, **824**, **826**, etc. As illustrated, SGSN **814** and GGSNs **822**, **824**, and **826** are part of internal packet network **820**. Gateway GPRS serving nodes **822**, **824** and **826** mainly provide an interface to external Internet Protocol (“IP”) networks such as Public Land Mobile Network (“PLMN”) **850**, corporate intranets **840**, or Fixed-End System (“FES”) or the public Internet **830**. As illustrated, subscriber corporate network **840** may be connected to GGSN **824** via firewall **832**; and PLMN **850** is connected to GGSN **824** via boarder gateway router **834**. The Remote Authentication Dial-In User Service (“RADIUS”) server **842** may be used for caller authentication when a user of a mobile cellular device calls corporate network **840**.

[0081] Generally, there can be a several cell sizes in a GSM network, referred to as macro, micro, pico, femto and umbrella cells. The coverage area of each cell is different in different environments. Macro cells can be regarded as cells in which the base station antenna is installed in a mast or a building above average roof top level. Micro cells are cells

whose antenna height is under average roof top level. Micro-cells are typically used in urban areas. Pico cells are small cells having a diameter of a few dozen meters. Pico cells are used mainly indoors. Femto cells have the same size as pico cells, but a smaller transport capacity. Femto cells are used indoors, in residential, or small business environments. On the other hand, umbrella cells are used to cover shadowed regions of smaller cells and fill in gaps in coverage between those cells.

[0082] FIG. 8 illustrates an architecture of a typical GPRS network within which locating a device via a text message as described herein may be implemented and/or communicate with. The architecture depicted in FIG. 8 may be segmented into four groups: users 950, radio access network 960, core network 970, and interconnect network 980. Users 950 comprise a plurality of end users. Note, device 912 is referred to as a mobile subscriber in the description of network shown in FIG. 8. In an example embodiment, the device depicted as mobile subscriber 912 comprises a communications device (e.g., communications device 160). Radio access network 960 comprises a plurality of base station subsystems such as BSSs 962, which include BTSs 964 and BSCs 966. Core network 970 comprises a host of various network elements. As illustrated in FIG. 8, core network 970 may comprise Mobile Switching Center (“MSC”) 971, Service Control Point (“SCP”) 972, gateway MSC 973, SGSN 976, Home Location Register (“HLR”) 974, Authentication Center (“AuC”) 975, Domain Name Server (“DNS”) 977, and GGSN 978. Interconnect network 980 also comprises a host of various networks and other network elements. As illustrated in FIG. 8, interconnect network 980 comprises Public Switched Telephone Network (“PSTN”) 982, Fixed-End System (“FES”) or Internet 984, firewall 988, and Corporate Network 989.

[0083] A mobile switching center can be connected to a large number of base station controllers. At MSC 971, for instance, depending on the type of traffic, the traffic may be separated in that voice may be sent to Public Switched Telephone Network (“PSTN”) 982 through Gateway MSC (“GMSC”) 973, and/or data may be sent to SGSN 976, which then sends the data traffic to GGSN 978 for further forwarding.

[0084] When MSC 971 receives call traffic, for example, from BSC 966, it sends a query to a database hosted by SCP 972. The SCP 972 processes the request and issues a response to MSC 971 so that it may continue call processing as appropriate.

[0085] The HLR 974 is a centralized database for users to register to the GPRS network. HLR 974 stores static information about the subscribers such as the International Mobile Subscriber Identity (“IMSI”), subscribed services, and a key for authenticating the subscriber. HLR 974 also stores dynamic subscriber information such as the current location of the mobile subscriber. Associated with HLR 974 is AuC 975. AuC 975 is a database that contains the algorithms for authenticating subscribers and includes the associated keys for encryption to safeguard the user input for authentication.

[0086] In the following, depending on context, the term “mobile subscriber” sometimes refers to the end user and sometimes to the actual portable device, such as a mobile device, used by an end user of the mobile cellular service. When a mobile subscriber turns on his or her mobile device, the mobile device goes through an attach process by which

the mobile device attaches to an SGSN of the GPRS network. In FIG. 8, when mobile subscriber 912 initiates the attach process by turning on the network capabilities of the mobile device, an attach request is sent by mobile subscriber 912 to SGSN 976. The SGSN 976 queries another SGSN, to which mobile subscriber 912 was attached before, for the identity of mobile subscriber 912. Upon receiving the identity of mobile subscriber 912 from the other SGSN, SGSN 976 requests more information from mobile subscriber 912. This information is used to authenticate mobile subscriber 912 to SGSN 976 by HLR 974. Once verified, SGSN 976 sends a location update to HLR 974 indicating the change of location to a new SGSN, in this case SGSN 976. HLR 974 notifies the old SGSN, to which mobile subscriber 912 was attached before, to cancel the location process for mobile subscriber 912. HLR 974 then notifies SGSN 976 that the location update has been performed. At this time, SGSN 976 sends an Attach Accept message to mobile subscriber 912, which in turn sends an Attach Complete message to SGSN 976.

[0087] After attaching itself with the network, mobile subscriber 912 then goes through the authentication process. In the authentication process, SGSN 976 sends the authentication information to HLR 974, which sends information back to SGSN 976 based on the user profile that was part of the user’s initial setup. The SGSN 976 then sends a request for authentication and ciphering to mobile subscriber 912. The mobile subscriber 912 uses an algorithm to send the user identification (ID) and password to SGSN 976. The SGSN 976 uses the same algorithm and compares the result. If a match occurs, SGSN 976 authenticates mobile subscriber 912.

[0088] Next, the mobile subscriber 912 establishes a user session with the destination network, corporate network 989, by going through a Packet Data Protocol (“PDP”) activation process. Briefly, in the process, mobile subscriber 912 requests access to the Access Point Name (“APN”), for example, UPS.com, and SGSN 976 receives the activation request from mobile subscriber 912. SGSN 976 then initiates a Domain Name Service (“DNS”) query to learn which GGSN node has access to the UPS.com APN. The DNS query is sent to the DNS server within the core network 970, such as DNS 977, which is provisioned to map to one or more GGSN nodes in the core network 970. Based on the APN, the mapped GGSN 978 can access the requested corporate network 989. The SGSN 976 then sends to GGSN 978 a Create Packet Data Protocol (“PDP”) Context Request message that contains necessary information. The GGSN 978 sends a Create PDP Context Response message to SGSN 976, which then sends an Activate PDP Context Accept message to mobile subscriber 912.

[0089] Once activated, data packets of the call made by mobile subscriber 912 can then go through radio access network 960, core network 970, and interconnect network 980, in a particular fixed-end system or Internet 984 and firewall 988, to reach corporate network 989.

[0090] FIG. 9 illustrates an example block diagram view of a GSM/GPRS/IP multimedia network architecture within which locating a device via a text message as described herein may be implemented. As illustrated, the architecture of FIG. 9 includes a GSM core network 1001, a GPRS network 1030 and an IP multimedia network 1038. The GSM core network 1001 includes a Mobile Station (MS) 1002, at least one Base Transceiver Station (BTS) 1004 and

a Base Station Controller (BSC) **1006**. The MS **1002** is physical equipment or Mobile Equipment (ME), such as a mobile phone or a laptop computer that is used by mobile subscribers, with a Subscriber Identity Module (SIM) or a Universal Integrated Circuit Card (UICC). The SIM or UICC includes an International Mobile Subscriber Identity (IMSI), which is a unique identifier of a subscriber. The BTS **1004** is physical equipment, such as a radio tower, that enables a radio interface to communicate with the MS. Each BTS may serve more than one MS. The BSC **1006** manages radio resources, including the BTS. The BSC may be connected to several BTSs. The BSC and BTS components, in combination, are generally referred to as a base station (BSS) or radio access network (RAN) **1003**.

[0091] The GSM core network **1001** also includes a Mobile Switching Center (MSC) **1008**, a Gateway Mobile Switching Center (GMSC) **1010**, a Home Location Register (HLR) **1012**, Visitor Location Register (VLR) **1014**, an Authentication Center (AuC) **1018**, and an Equipment Identity Register (EIR) **1016**. The MSC **1008** performs a switching function for the network. The MSC also performs other functions, such as registration, authentication, location updating, handovers, and call routing. The GMSC **1010** provides a gateway between the GSM network and other networks, such as an Integrated Services Digital Network (ISDN) or Public Switched Telephone Networks (PSTNs) **1020**. Thus, the GMSC **1010** provides interworking functionality with external networks.

[0092] The HLR **1012** is a database that contains administrative information regarding each subscriber registered in a corresponding GSM network. The HLR **1012** also contains the current location of each MS. The VLR **1014** is a database that contains selected administrative information from the HLR **1012**. The VLR contains information necessary for call control and provision of subscribed services for each MS currently located in a geographical area controlled by the VLR. The HLR **1012** and the VLR **1014**, together with the MSC **1008**, provide the call routing and roaming capabilities of GSM. The AuC **1018** provides the parameters needed for authentication and encryption functions. Such parameters allow verification of a subscriber's identity. The EIR **1016** stores security-sensitive information about the mobile equipment.

[0093] A Short Message Service Center (SMSC) **1009** allows one-to-one Short Message Service (SMS) messages to be sent to/from the MS **1002**. A Push Proxy Gateway (PPG) **1011** is used to "push" (i.e., send without a synchronous request) content to the MS **1002**. The PPG **1011** acts as a proxy between wired and wireless networks to facilitate pushing of data to the MS **1002**. A Short Message Peer to Peer (SMPP) protocol router **1013** is provided to convert SMS-based SMPP messages to cell broadcast messages. SMPP is a protocol for exchanging SMS messages between SMS peer entities such as short message service centers. The SMPP protocol is often used to allow third parties, e.g., content suppliers such as news organizations, to submit bulk messages.

[0094] To gain access to GSM services, such as speech, data, and short message service (SMS), the MS first registers with the network to indicate its current location by performing a location update and IMSI attach procedure. The MS **1002** sends a location update including its current location information to the MSC/VLR, via the BTS **1004** and the BSC **1006**. The location information is then sent to the MS's

HLR. The HLR is updated with the location information received from the MSC/VLR. The location update also is performed when the MS moves to a new location area. Typically, the location update is periodically performed to update the database as location updating events occur.

[0095] The GPRS network **1030** is logically implemented on the GSM core network architecture by introducing two packet-switching network nodes, a serving GPRS support node (SGSN) **1032**, a cell broadcast and a Gateway GPRS support node (GGSN) **1034**. The SGSN **1032** is at the same hierarchical level as the MSC **1008** in the GSM network. The SGSN controls the connection between the GPRS network and the MS **1002**. The SGSN also keeps track of individual MS's locations and security functions and access controls.

[0096] A Cell Broadcast Center (CBC) **14** communicates cell broadcast messages that are typically delivered to multiple users in a specified area. Cell Broadcast is one-to-many geographically focused service. It enables messages to be communicated to multiple mobile phone customers who are located within a given part of its network coverage area at the time the message is broadcast.

[0097] The GGSN **1034** provides a gateway between the GPRS network and a public packet network (PDN) or other IP networks **1036**. That is, the GGSN provides interworking functionality with external networks, and sets up a logical link to the MS through the SGSN. When packet-switched data leaves the GPRS network, it is transferred to an external TCP-IP network **1036**, such as an X.25 network or the Internet. In order to access GPRS services, the MS first attaches itself to the GPRS network by performing an attach procedure. The MS then activates a packet data protocol (PDP) context, thus activating a packet communication session between the MS, the SGSN, and the GGSN.

[0098] In a GSM/GPRS network, GPRS services and GSM services can be used in parallel. The MS can operate in one of three classes: class A, class B, and class C. A class A MS can attach to the network for both GPRS services and GSM services simultaneously. A class A MS also supports simultaneous operation of GPRS services and GSM services. For example, class A mobiles can receive GSM voice/data/SMS calls and GPRS data calls at the same time.

[0099] A class B MS can attach to the network for both GPRS services and GSM services simultaneously. However, a class B MS does not support simultaneous operation of the GPRS services and GSM services. That is, a class B MS can only use one of the two services at a given time.

[0100] A class C MS can attach for only one of the GPRS services and GSM services at a time. Simultaneous attachment and operation of GPRS services and GSM services is not possible with a class C MS.

[0101] A GPRS network **1030** can be designed to operate in three network operation modes (NOM1, NOM2 and NOM3). A network operation mode of a GPRS network is indicated by a parameter in system information messages transmitted within a cell. The system information messages dictates a MS where to listen for paging messages and how to signal towards the network. The network operation mode represents the capabilities of the GPRS network. In a NOM1 network, a MS can receive pages from a circuit switched domain (voice call) when engaged in a data call. The MS can suspend the data call or take both simultaneously, depending on the ability of the MS. In a NOM2 network, a MS may not receive pages from a circuit switched domain when engaged

in a data call, since the MS is receiving data and is not listening to a paging channel. In a NOM3 network, a MS can monitor pages for a circuit switched network while received data and vice versa.

[0102] The IP multimedia network **1038** was introduced with 3GPP Release 5, and includes an IP multimedia subsystem (IMS) **1040** to provide rich multimedia services to end users. A representative set of the network entities within the IMS **1040** are a call/session control function (CSCF), a media gateway control function (MGCF) **1046**, a media gateway (MGW) **1048**, and a master subscriber database, called a home subscriber server (HSS) **1050**. The HSS **1050** may be common to the GSM network **1001**, the GPRS network **1030** as well as the IP multimedia network **1038**.

[0103] The IP multimedia system **1040** is built around the call/session control function, of which there are three types: an interrogating CSCF (I-CSCF) **1043**, a proxy CSCF (P-CSCF) **1042**, and a serving CSCF (S-CSCF) **1044**. The P-CSCF **1042** is the MS's first point of contact with the IMS **1040**. The P-CSCF **1042** forwards session initiation protocol (SIP) messages received from the MS to an SIP server in a home network (and vice versa) of the MS. The P-CSCF **1042** may also modify an outgoing request according to a set of rules defined by the network operator (for example, address analysis and potential modification).

[0104] The I-CSCF **1043**, forms an entrance to a home network and hides the inner topology of the home network from other networks and provides flexibility for selecting an S-CSCF. The I-CSCF **1043** may contact a subscriber location function (SLF) **1045** to determine which HSS **1050** to use for the particular subscriber, if multiple HSS's **1050** are present. The S-CSCF **1044** performs the session control services for the MS **1002**. This includes routing originating sessions to external networks and routing terminating sessions to visited networks. The S-CSCF **1044** also decides whether an application server (AS) **1052** is required to receive information on an incoming SIP session request to ensure appropriate service handling. This decision is based on information received from the HSS **1050** (or other sources, such as an application server **1052**). The AS **1052** also communicates to a location server **1056** (e.g., a Gateway Mobile Location Center (GMLC)) that provides a position (e.g., latitude/longitude coordinates) of the MS **1002**.

[0105] The HSS **1050** contains a subscriber profile and keeps track of which core network node is currently handling the subscriber. It also supports subscriber authentication and authorization functions (AAA). In networks with more than one HSS **1050**, a subscriber location function provides information on the HSS **1050** that contains the profile of a given subscriber.

[0106] The MGCF **1046** provides interworking functionality between SIP session control signaling from the IMS **1040** and ISUP/BICC call control signaling from the external GSTN networks (not shown). It also controls the media gateway (MGW) **1048** that provides user-plane interworking functionality (e.g., converting between AMR- and PCM-coded voice). The MGW **1048** also communicates with other IP multimedia networks **1054**.

[0107] Push to Talk over Cellular (PoC) capable mobile phones register with the wireless network when the phones are in a predefined area (e.g., job site, etc.). When the mobile phones leave the area, they register with the network in their new location as being outside the predefined area. This

registration, however, does not indicate the actual physical location of the mobile phones outside the pre-defined area.

[0108] FIG. 10 illustrates a PLMN block diagram view of an example architecture in which locating a device via a text message as described herein may be implemented. Mobile Station (MS) **1401** is the physical equipment used by the PLMN subscriber. In one illustrative embodiment, communications device **200** may serve as Mobile Station **1401**. Mobile Station **1401** may be one of, but not limited to, a cellular telephone, a cellular telephone in combination with another electronic device or any other wireless mobile communication device.

[0109] Mobile Station **1401** may communicate wirelessly with Base Station System (BSS) **1410**. BSS **1410** contains a Base Station Controller (BSC) **1411** and a Base Transceiver Station (BTS) **1412**. BSS **1410** may include a single BSC **1411**/BTS **1412** pair (Base Station) or a system of BSC/BTS pairs which are part of a larger network. BSS **1410** is responsible for communicating with Mobile Station **1401** and may support one or more cells. BSS **1410** is responsible for handling cellular traffic and signaling between Mobile Station **1401** and Core Network **1440**. Typically, BSS **1410** performs functions that include, but are not limited to, digital conversion of speech channels, allocation of channels to mobile devices, paging, and transmission/reception of cellular signals.

[0110] Additionally, Mobile Station **1401** may communicate wirelessly with Radio Network System (RNS) **1420**. RNS **1420** contains a Radio Network Controller (RNC) **1421** and one or more Node(s) B **1422**. RNS **1420** may support one or more cells. RNS **1420** may also include one or more RNC **1421**/Node B **1422** pairs or alternatively a single RNC **1421** may manage multiple Nodes B **1422**. RNS **1420** is responsible for communicating with Mobile Station **1401** in its geographically defined area. RNC **1421** is responsible for controlling the Node(s) B **1422** that are connected to it and is a control element in a UMTS radio access network. RNC **1421** performs functions such as, but not limited to, load control, packet scheduling, handover control, security functions, as well as controlling Mobile Station **1401**'s access to the Core Network (CN) **1440**.

[0111] The evolved UMTS Terrestrial Radio Access Network (E-UTRAN) **1430** is a radio access network that provides wireless data communications for Mobile Station **1401** and User Equipment **1402**. E-UTRAN **1430** provides higher data rates than traditional UMTS. It is part of the Long Term Evolution (LTE) upgrade for mobile networks and later releases meet the requirements of the International Mobile Telecommunications (IMT) Advanced and are commonly known as a 4G networks. E-UTRAN **1430** may include of series of logical network components such as E-UTRAN Node B (eNB) **1431** and E-UTRAN Node B (eNB) **1432**. E-UTRAN **1430** may contain one or more eNBs. User Equipment **1402** may be any user device capable of connecting to E-UTRAN **1430** including, but not limited to, a personal computer, laptop, mobile device, wireless router, or other device capable of wireless connectivity to E-UTRAN **1430**. The improved performance of the E-UTRAN **1430** relative to a typical UMTS network allows for increased bandwidth, spectral efficiency, and functionality including, but not limited to, voice, high-speed applications, large data transfer and IPTV, while still allowing for full mobility.

[0112] An example embodiment of a mobile data and communication service that may be implemented in the PLMN architecture described in FIG. 10 is the Enhanced Data rates for GSM Evolution (EDGE). EDGE is an enhancement for GPRS networks that implements an improved signal modulation scheme known as 8-PSK (Phase Shift Keying). By increasing network utilization, EDGE may achieve up to three times faster data rates as compared to a typical GPRS network. EDGE may be implemented on any GSM network capable of hosting a GPRS network, making it an ideal upgrade over GPRS since it may provide increased functionality of existing network resources. Evolved EDGE networks are becoming standardized in later releases of the radio telecommunication standards, which provide for even greater efficiency and peak data rates of up to 1 Mbit/s, while still allowing implementation on existing GPRS-capable network infrastructure.

[0113] Typically Mobile Station 1401 may communicate with any or all of BSS 1410, RNS 1420, or E-UTRAN 1430. In a illustrative system, each of BSS 1410, RNS 1420, and E-UTRAN 1430 may provide Mobile Station 1401 with access to Core Network 1440. The Core Network 1440 may include a series of devices that route data and communications between end users. Core Network 1440 may provide network service functions to users in the Circuit Switched (CS) domain, the Packet Switched (PS) domain or both. The CS domain refers to connections in which dedicated network resources are allocated at the time of connection establishment and then released when the connection is terminated. The PS domain refers to communications and data transfers that make use of autonomous groupings of bits called packets. Each packet may be routed, manipulated, processed or handled independently of all other packets in the PS domain and does not require dedicated network resources.

[0114] The Circuit Switched-Media Gateway Function (CS-MGW) 1441 is part of Core Network 1440, and interacts with Visitor Location Register (VLR) and Mobile-Services Switching Center (MSC) Server 1460 and Gateway MSC Server 1461 in order to facilitate Core Network 1440 resource control in the CS domain. Functions of CS-MGW 1441 include, but are not limited to, media conversion, bearer control, payload processing and other mobile network processing such as handover or anchoring. CS-MGW 1440 may receive connections to Mobile Station 1401 through BSS 1410, RNS 1420 or both.

[0115] Serving GPRS Support Node (SGSN) 1442 stores subscriber data regarding Mobile Station 1401 in order to facilitate network functionality. SGSN 1442 may store subscription information such as, but not limited to, the International Mobile Subscriber Identity (IMSI), temporary identities, or Packet Data Protocol (PDP) addresses. SGSN 1442 may also store location information such as, but not limited to, the Gateway GPRS Support Node (GGSN) 1444 address for each GGSN where an active PDP exists. GGSN 1444 may implement a location register function to store subscriber data it receives from SGSN 1442 such as subscription or location information.

[0116] Serving Gateway (S-GW) 1443 is an interface which provides connectivity between E-UTRAN 1430 and Core Network 1440. Functions of S-GW 1443 include, but are not limited to, packet routing, packet forwarding, transport level packet processing, event reporting to Policy and Charging Rules Function (PCRF) 1450, and mobility

anchoring for inter-network mobility. PCRF 1450 uses information gathered from S-GW 1443, as well as other sources, to make applicable policy and charging decisions related to data flows, network resources and other network administration functions. Packet Data Network Gateway (PDN-GW) 1445 may provide user-to-services connectivity functionality including, but not limited to, network-wide mobility anchoring, bearer session anchoring and control, and IP address allocation for PS domain connections.

[0117] Home Subscriber Server (HSS) 1463 is a database for user information, and stores subscription data regarding Mobile Station 1401 or User Equipment 1402 for handling calls or data sessions. Networks may contain one HSS 1463 or more if additional resources are required. Example data stored by HSS 1463 include, but is not limited to, user identification, numbering and addressing information, security information, or location information. HSS 1463 may also provide call or session establishment procedures in both the PS and CS domains.

[0118] The VLR/MSC Server 1460 provides user location functionality. When Mobile Station 1401 enters a new network location, it begins a registration procedure. A MSC Server for that location transfers the location information to the VLR for the area. A VLR and MSC Server may be located in the same computing environment, as is shown by VLR/MSC Server 1460, or alternatively may be located in separate computing environments. A VLR may contain, but is not limited to, user information such as the IMSI, the Temporary Mobile Station Identity (TMSI), the Local Mobile Station Identity (LMSI), the last known location of the mobile station, or the SGSN where the mobile station was previously registered. The MSC server may contain information such as, but not limited to, procedures for Mobile Station 1401 registration or procedures for handover of Mobile Station 1401 to a different section of the Core Network 1440. GMSC Server 1461 may serve as a connection to alternate GMSC Servers for other mobile stations in larger networks.

[0119] Equipment Identity Register (EIR) 1462 is a logical element which may store the International Mobile Equipment Identities (IMEI) for Mobile Station 1401. In a typical embodiment, user equipment may be classified as either "white listed" or "black listed" depending on its status in the network. In one embodiment, if Mobile Station 1401 is stolen and put to use by an unauthorized user, it may be registered as "black listed" in EIR 1462, preventing its use on the network. Mobility Management Entity (MME) 1464 is a control node which may track Mobile Station 1401 or User Equipment 1402 if the devices are idle. Additional functionality may include the ability of MME 1464 to contact an idle Mobile Station 1401 or User Equipment 1402 if retransmission of a previous session is required.

[0120] While example embodiments of locating a device via a text message have been described in connection with various computing devices/processors, the underlying concepts may be applied to any computing device, processor, or system capable of facilitating locating a device via a text message. The various techniques described herein may be implemented in connection with hardware or software or, where appropriate, with a combination of both. Thus, the methods and apparatuses of locating a device via a text message, or certain aspects or portions thereof, may take the form of program code (i.e., instructions) embodied in concrete, tangible, storage media having a concrete, tangible,

physical structure. Examples of tangible storage media include floppy diskettes, CD-ROMs, DVDs, hard drives, or any other tangible machine-readable storage medium (computer-readable storage medium). Thus, a computer-readable storage medium is not a transient signal per se. Further, a computer-readable storage medium is not a propagating signal per se. A computer-readable storage medium as described herein is an article of manufacture. When the program code is loaded into and executed by a machine, such as a computer, the machine becomes an apparatus for implementation of locating a device via a text message as described herein. In the case of program code execution on programmable computers, the computing device will generally include a processor, a storage medium readable by the processor (including volatile and non-volatile memory and/or storage elements), at least one input device, and at least one output device. The program(s) can be implemented in assembly or machine language, if desired. The language can be a compiled or interpreted language, and combined with hardware implementations.

[0121] The methods and apparatuses for locating a device via a text message as described herein also may be practiced via communications embodied in the form of program code that is transmitted over some transmission medium, such as over electrical wiring or cabling, through fiber optics, or via any other form of transmission, wherein, when the program code is received and loaded into and executed by a machine, such as an EPROM, a gate array, a programmable logic device (PLD), a client computer, or the like, the machine becomes an apparatus for implementing location of a device via a text message as described herein. When implemented on a general-purpose processor, the program code combines with the processor to provide a unique apparatus that operates to invoke the functionality of locating a device via a text message as described herein.

[0122] While locating a device via a text message has been described in connection with the various embodiments of the various figures, it is to be understood that other similar embodiments may be used or modifications and additions may be made to the described embodiments of locating a device via a text message without deviating therefrom. For example, one skilled in the art will recognize that locating a device via a text message as described in the instant application may apply to any environment, whether wired or wireless, and may be applied to any number of such devices connected via a communications network and interacting across the network. Therefore, a device farm as described herein should not be limited to any single embodiment, but rather should be construed in breadth and scope in accordance with the appended claims.

What is claimed:

1. An apparatus comprising:
 - a processor; and
 - memory coupled with the processor, the memory comprising executable instructions that when executed by the processor cause the processor to effectuate operations comprising:
 - receiving a text message for a device, the text message comprising:
 - an address of the device, and
 - a region of interest;
 - providing a location of the device when the location of the device is within the region of interest, the loca-

- tion of the device provided in a format compatible for rendering with a geographical map; and
- restricting forwarding of the text message to the device based on a determination that:

- the text message comprises a code indicative of a request for the location of the device, and
 - the text message does not comprise a message for the device at the address.

2. The apparatus of claim 1, wherein the apparatus comprises at least one of a mobile switching center, a short message service center, a consolidated network repository, a service mobile location center, or a radio access network.

3. The apparatus of claim 1, wherein the text message comprises an image indicative of the location of the device.

4. The apparatus of claim 1, further operations comprising determining, based on the received text message, whether a provider of the text message is authorized to receive an indication of the location of the device.

5. The apparatus of claim 1, wherein the text message is formatted as short message service message.

6. The apparatus of claim 1, wherein the address of the device comprises a phone number of the device.

7. The apparatus of claim 1, wherein the providing the location of the device is associated with vibration of a mobile device that sent the text message.

8. The apparatus of claim 1, wherein the address of the device comprises a phone number of the device.

9. The apparatus of claim 1, wherein the apparatus comprises a combined home location register and home subscriber server.

10. A method comprising:

- receiving, by an apparatus, a text message for a device, the text message comprising an address of the device and a region of interest;

- providing a location of the device when the location of the device is within the region of interest, the location of the device provided in a format compatible for rendering with a geographical map; and

- restricting forwarding of the text message to the device based on a determination that:

- the text message comprises a code indicative of a request for the location of the device, and
 - the text message does not comprise a message for the device at the address.

11. The method of claim 10, wherein the apparatus comprises at least one of a mobile switching center, a short message service center, a consolidated network repository, a service mobile location center, or a radio access network.

12. The method of claim 10, wherein the text message comprises an image indicative of the location of the device.

13. The method of claim 10, further comprising determining, based on the received text message, whether a provider of the text message is authorized to receive an indication of the location of the device.

14. The method of claim 10, wherein the text message is formatted as short message service message.

15. The method of claim 10, wherein the address of the device comprises a phone number of the device.

16. The method of claim 10, wherein the providing the location of the device is associated with vibration of a mobile device that sent the text message.

17. The method of claim 10, wherein the address of the device comprises a phone number of the device.

18. The method of claim **10**, wherein the apparatus comprises a combined home location register and home subscriber server.

19. A computer-readable storage medium that is not a transient signal comprising executable instructions that when executed by a processor cause the processor to effectuate operations comprising:

- receiving, by an apparatus, a text message for a device, the text message comprising:
 - an address of the device, and
 - a region of interest;

- providing a location of the device when the location of the device is within the region of interest, the location of the device provided in a format compatible for rendering with a geographical map; and

- restricting forwarding of the text message to the device based on a determination that:

- the text message comprises a code indicative of a request for the location of the device, and

- the text message does not comprise a message for the device at the address.

20. The computer-readable storage medium of claim **19**, wherein the apparatus comprises at least one of a mobile switching center, a short message service center, a consolidated network repository, a service mobile location center, or a radio access network.

* * * * *