



(19) **United States**

(12) **Patent Application Publication**  
**Jessop et al.**

(10) **Pub. No.: US 2018/0318041 A1**

(43) **Pub. Date: Nov. 8, 2018**

(54) **CHEEK AND LIP EXPANSION DEVICE AND METHOD**

**Publication Classification**

(71) Applicant: **ULTRADENT PRODUCTS, INC.**,  
South Jordan, UT (US)

(51) **Int. Cl.**  
*A61C 5/90* (2006.01)

(72) Inventors: **Neil T. Jessop**, Sandy, UT (US); **Bruce S. McLean**, Sandy, UT (US); **Craig Hines**, Lihue, HI (US)

(52) **U.S. Cl.**  
CPC . *A61C 5/90* (2017.02); *A61B 1/24* (2013.01)

(21) Appl. No.: **16/030,591**

(57) **ABSTRACT**

(22) Filed: **Jul. 9, 2018**

Cheek and lip expansion devices including an upper frame portion configured to extend about an upper dental arch, and a lower frame portion configured to extend about a lower dental arch. The upper and lower frame portions may each include first and second side members, each with anterior and posterior regions. An upper connecting member may extend between the anterior regions of the upper side members. A lower connecting member may extend between the anterior regions of the lower side members. The posterior regions of the upper and lower side members on respective sides of the frame are joined to one another to form a bendable radius that resists bending at a distinct point. The bendable radius on opposed sides permits the frame to be collapsed top to bottom. The frame may be collapsible side-to-side. A posterior crossbar may be provided extending between the posterior regions of the side members.

**Related U.S. Application Data**

(63) Continuation of application No. 14/858,954, filed on Sep. 18, 2015, now Pat. No. 10,016,258, which is a continuation-in-part of application No. 14/776,867, filed on Sep. 15, 2015, now Pat. No. 9,901,332, filed as application No. PCT/US2014/028083 on Mar. 14, 2014.

(60) Provisional application No. 61/789,929, filed on Mar. 15, 2013.

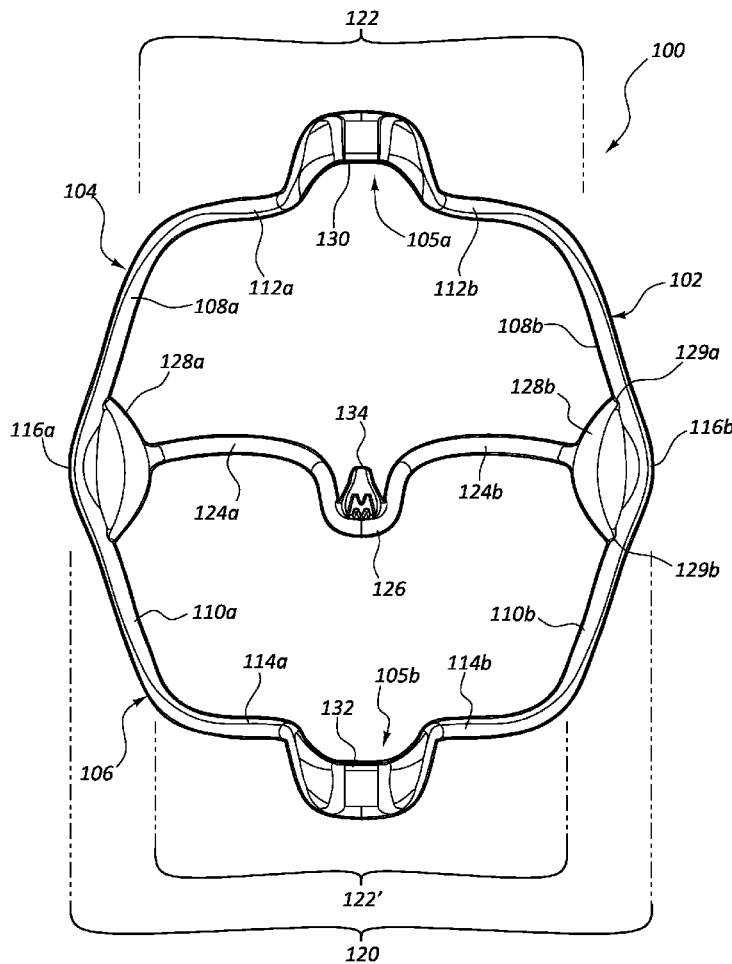

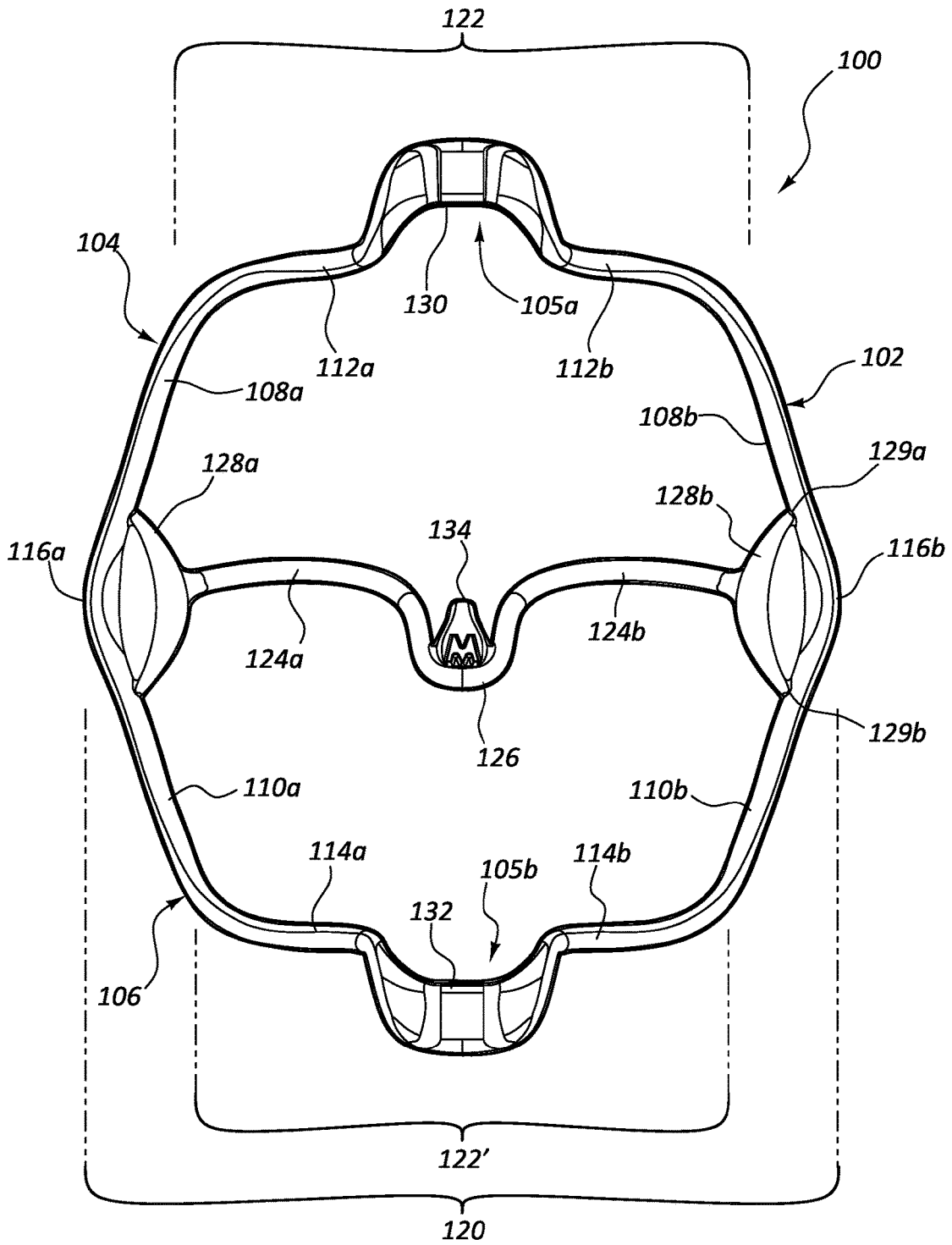
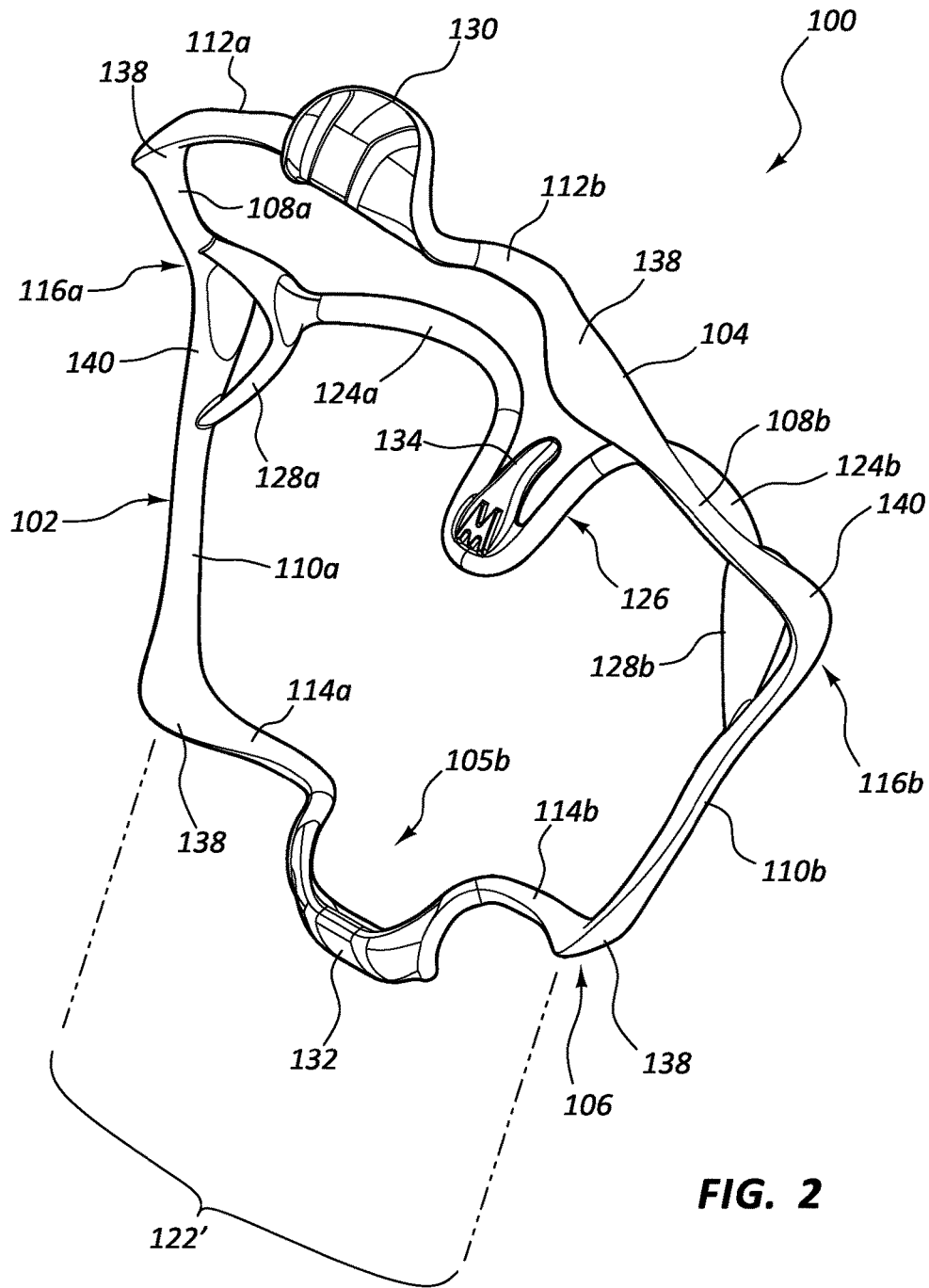
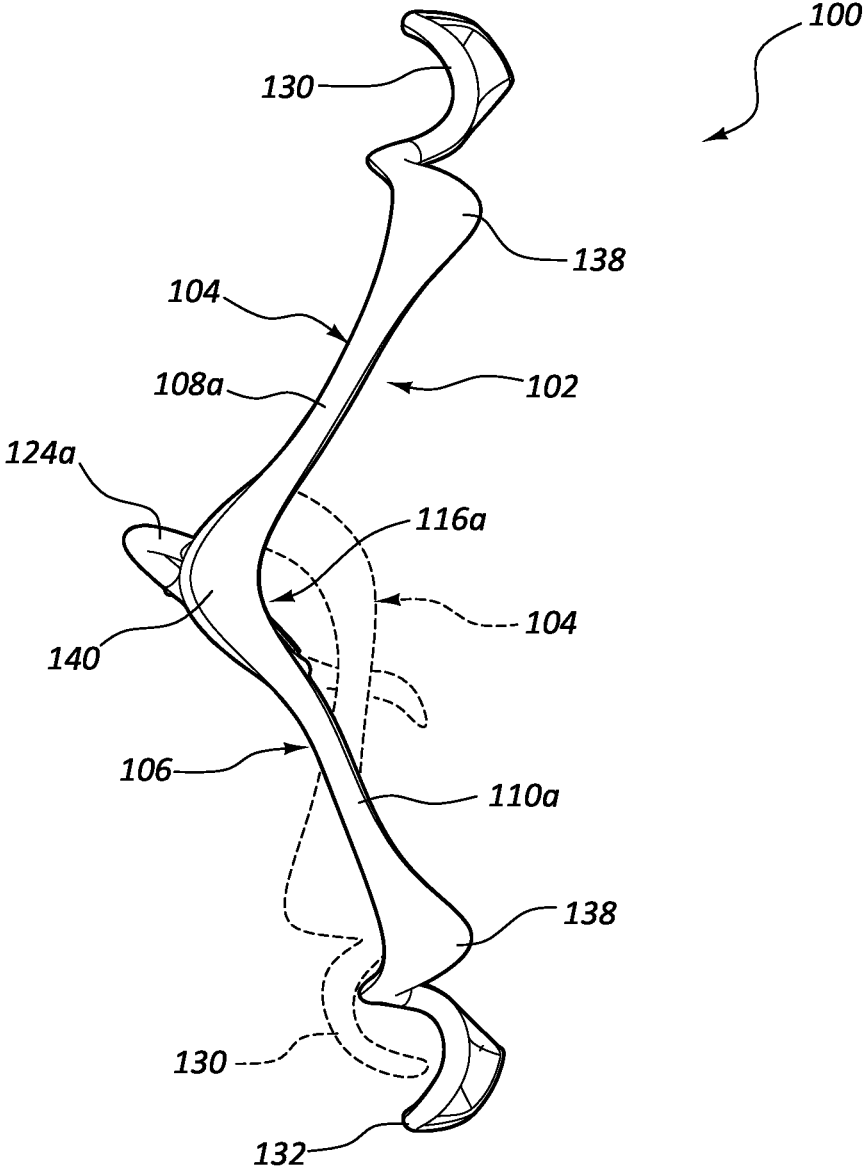

FIG. 1



**FIG. 2**



**FIG. 3**

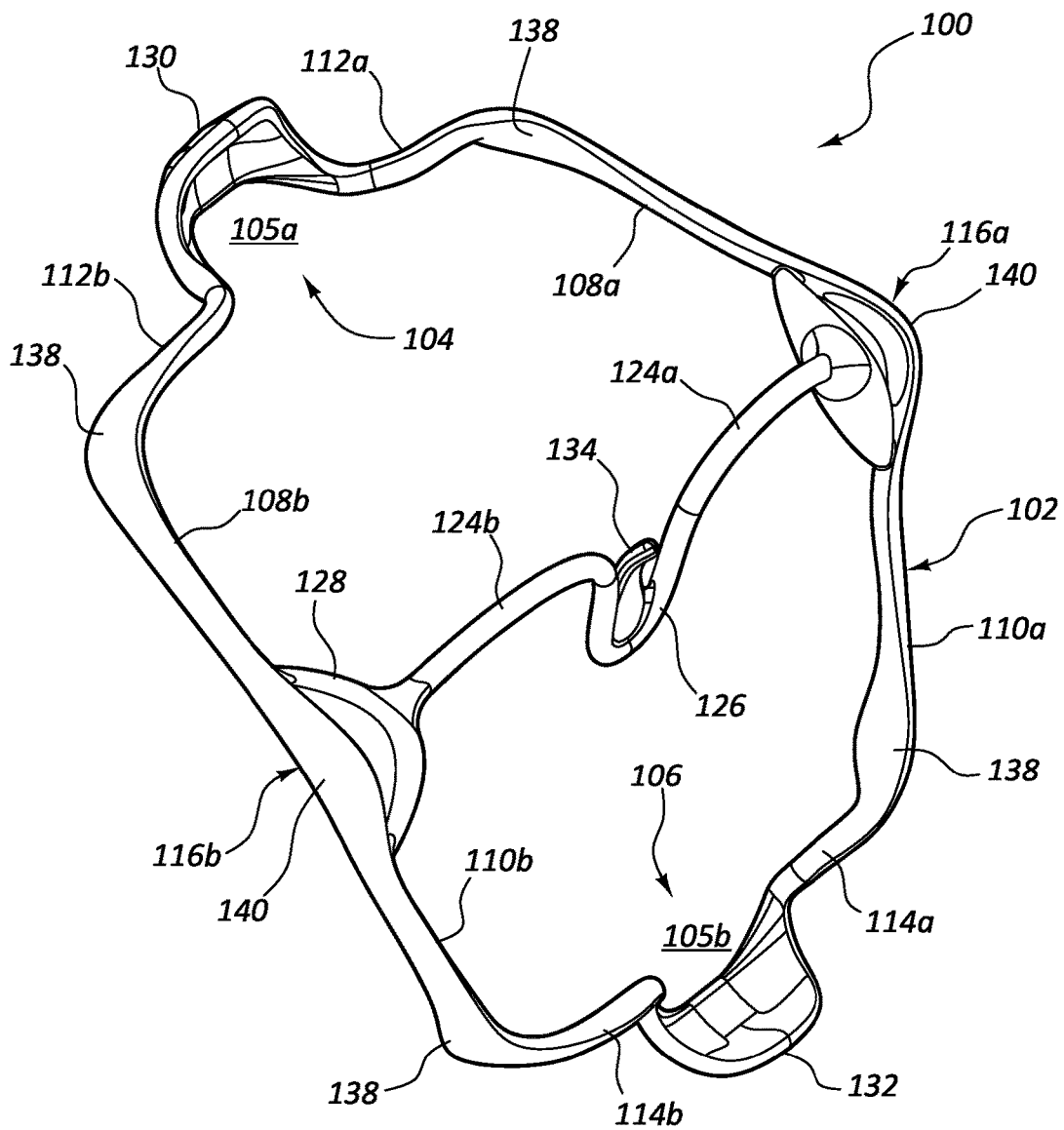

**FIG. 4**

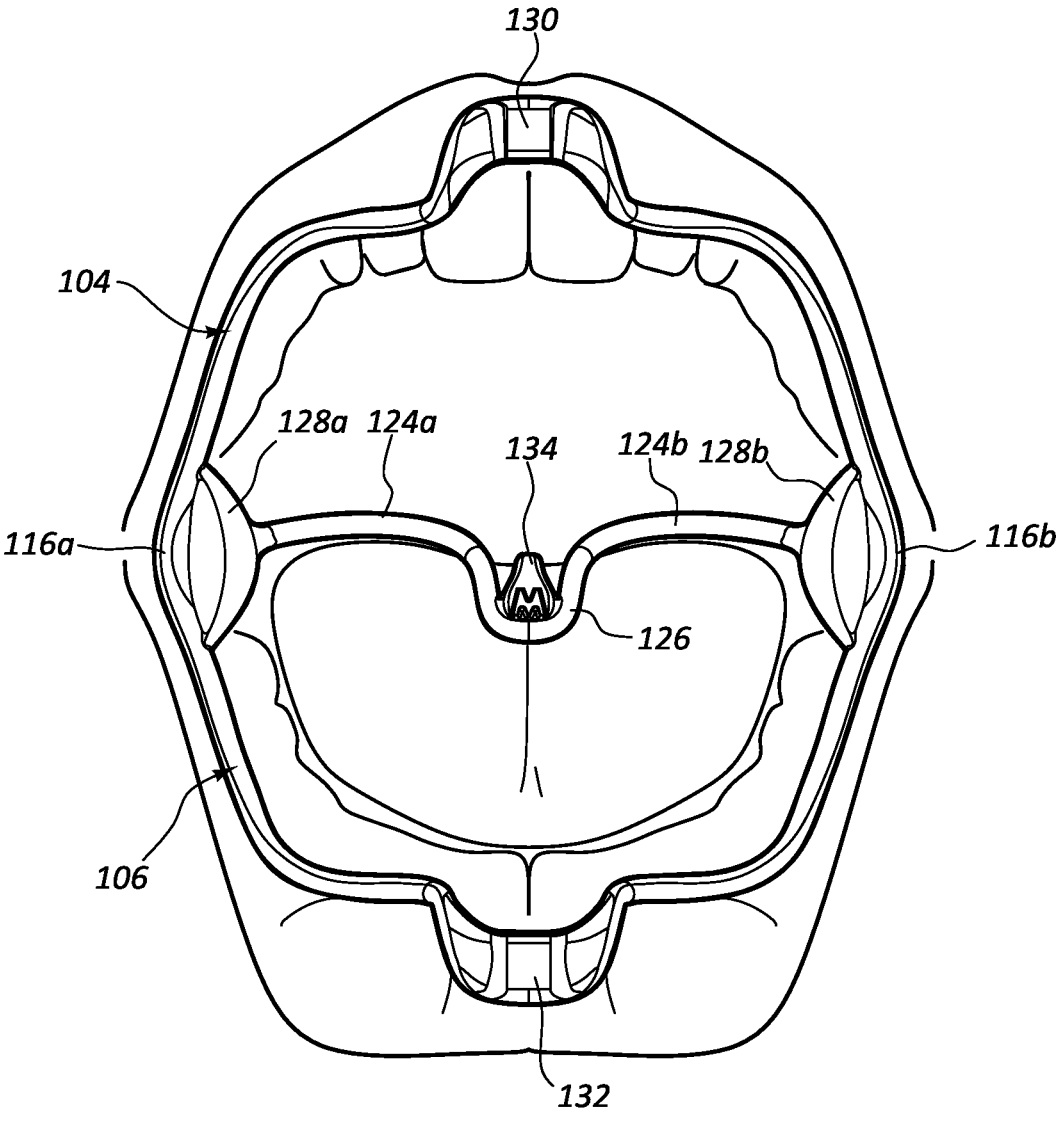

**FIG. 5**

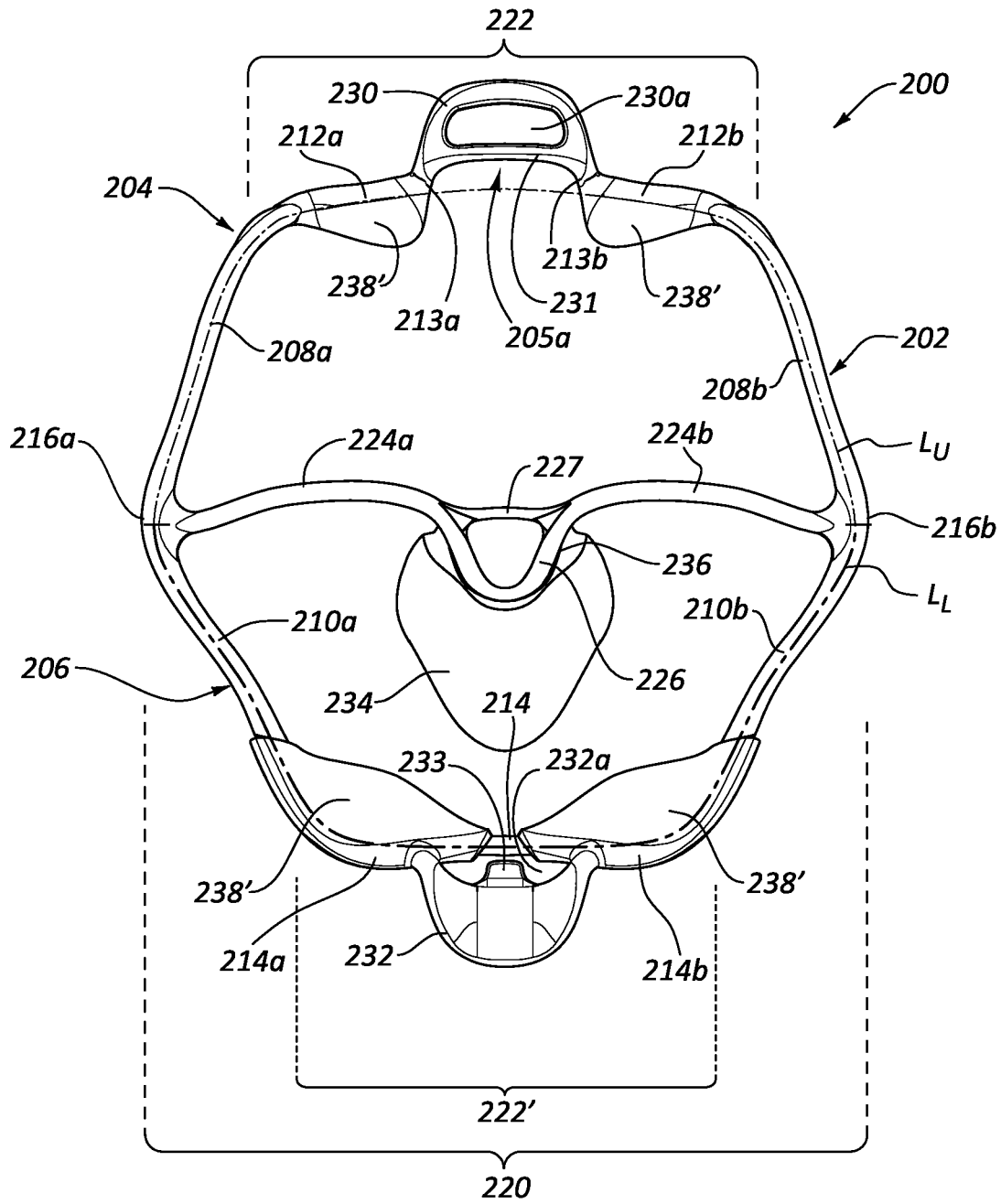
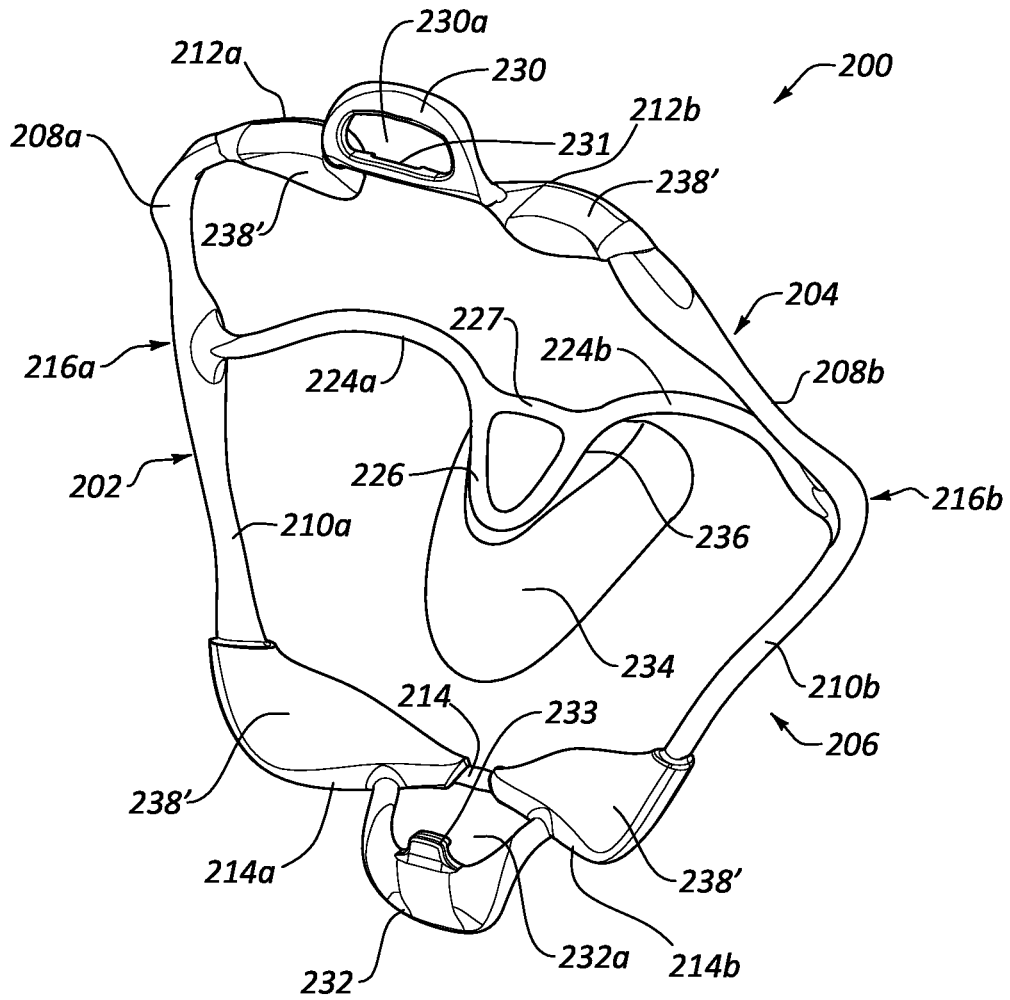
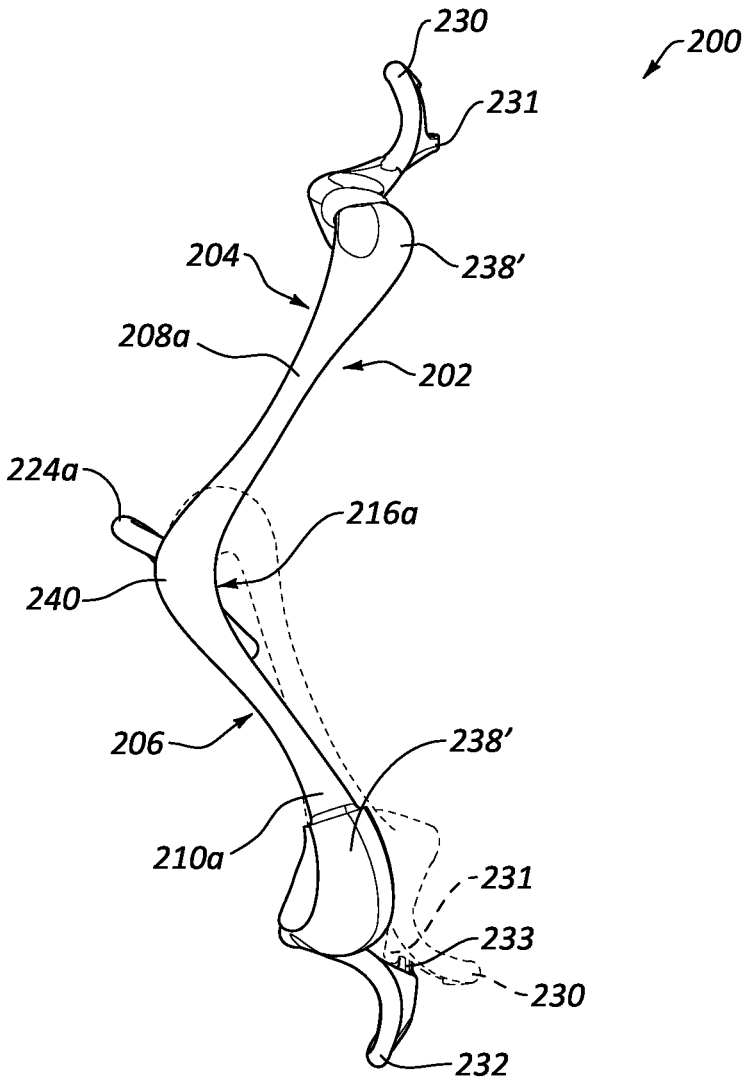

FIG. 6

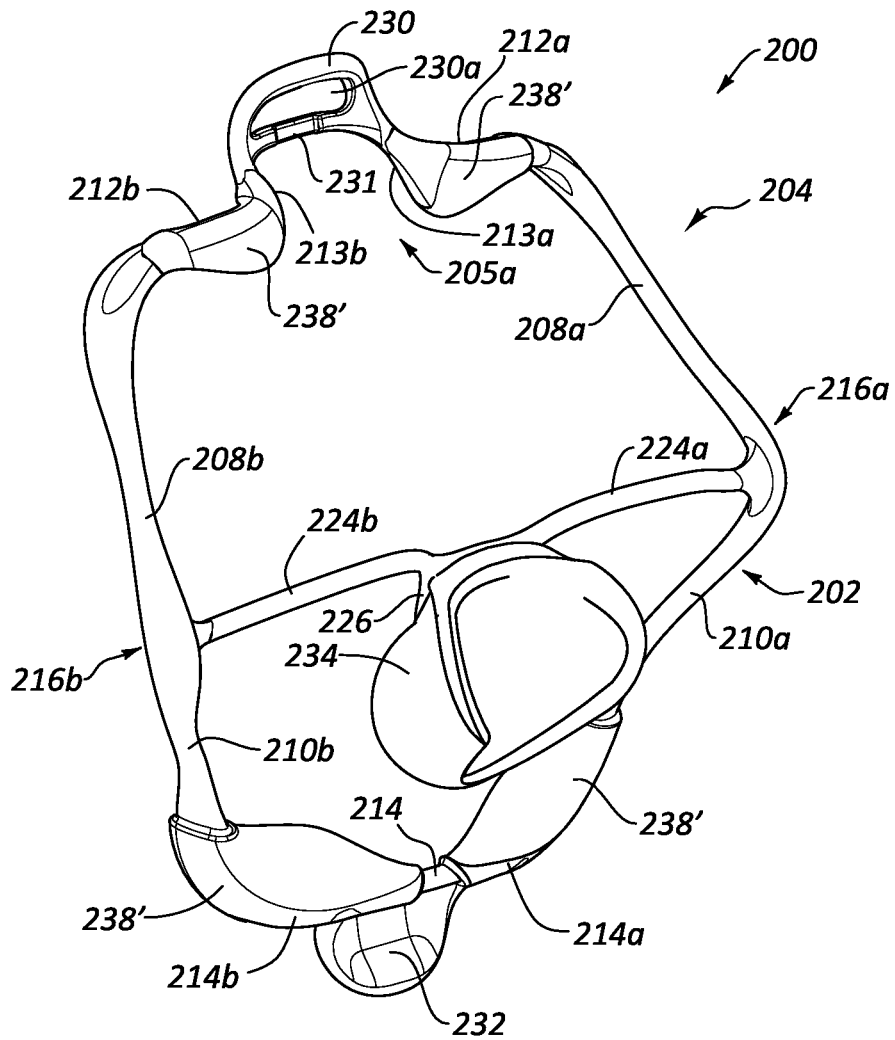

**FIG. 7**





**FIG. 8**



**FIG. 9**

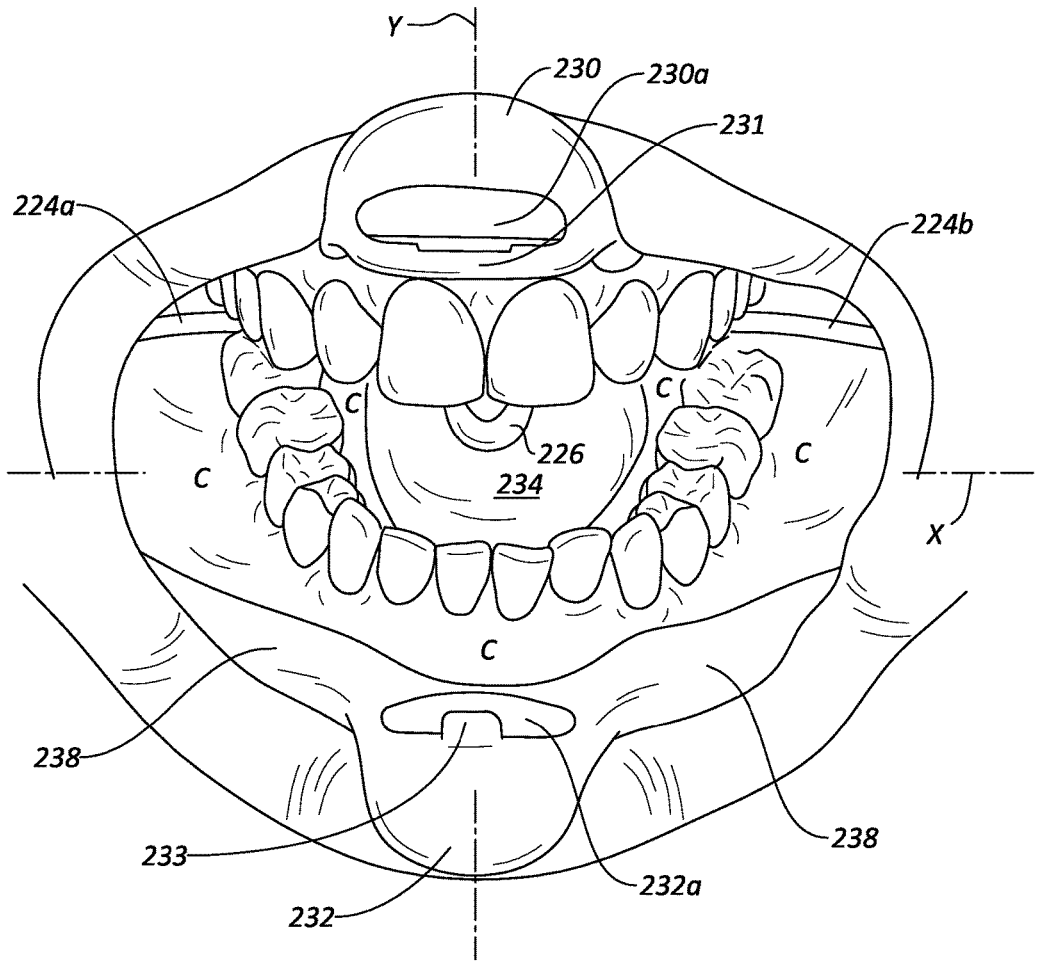
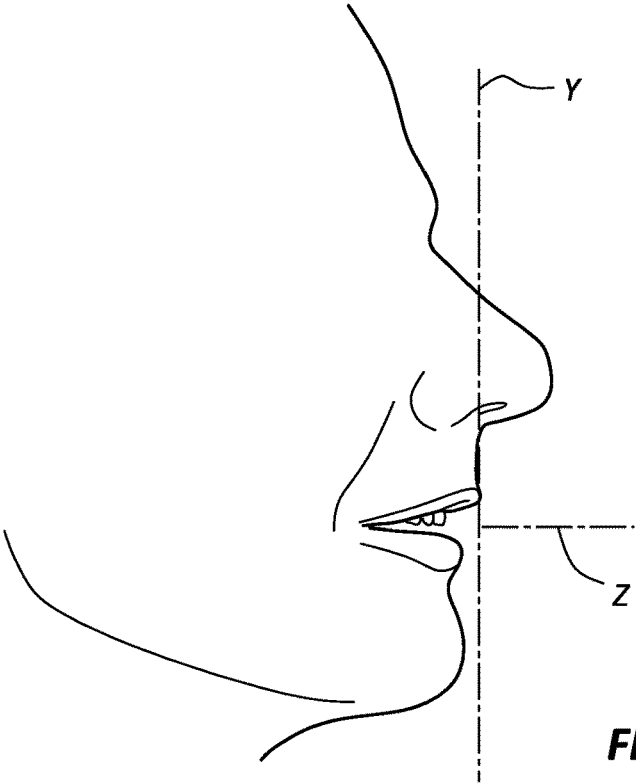
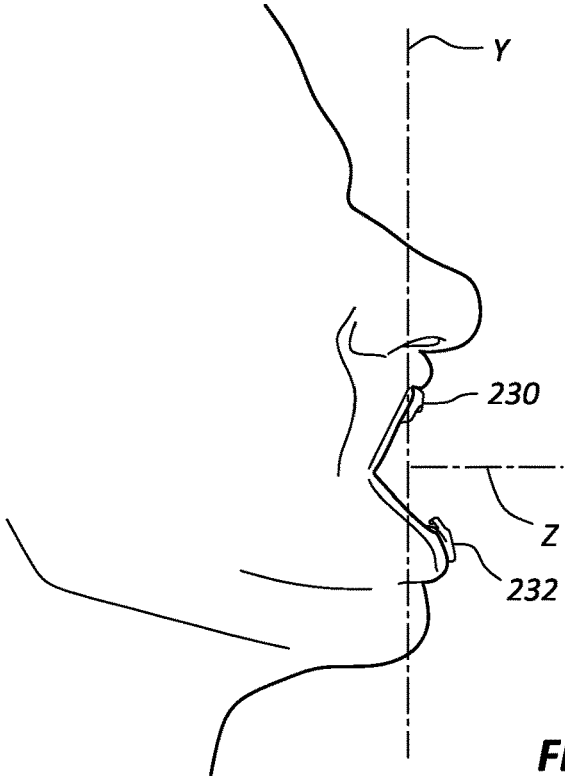

FIG. 10A



**FIG. 10B**



**FIG. 10C**

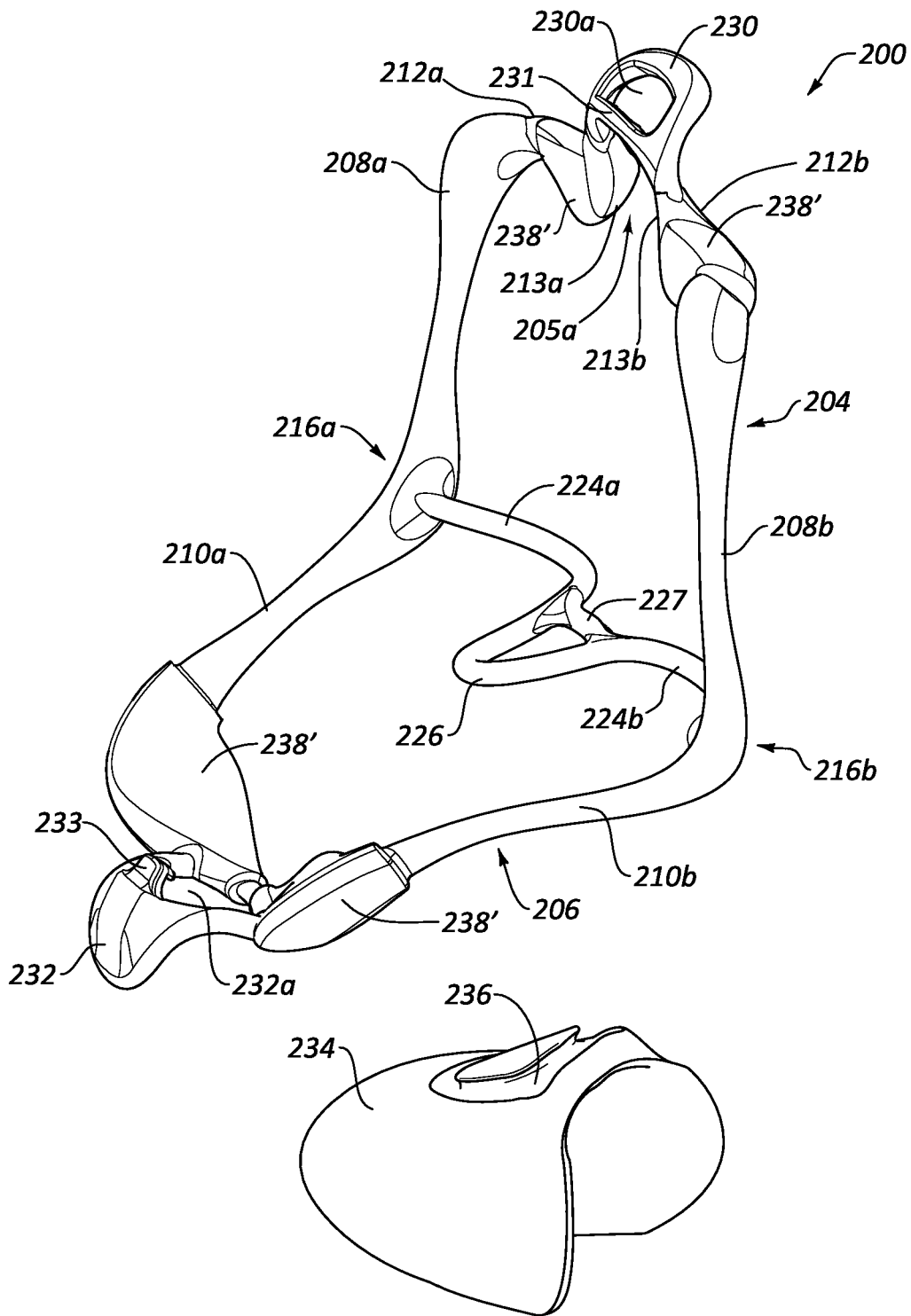
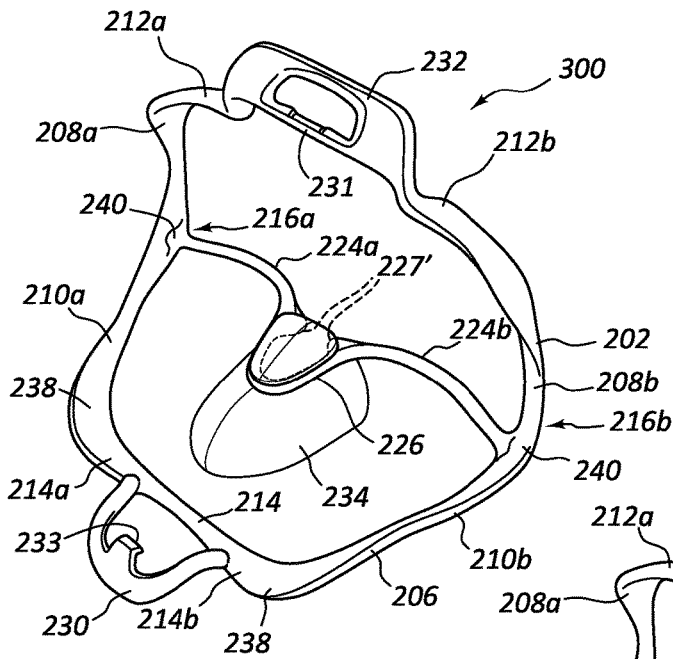
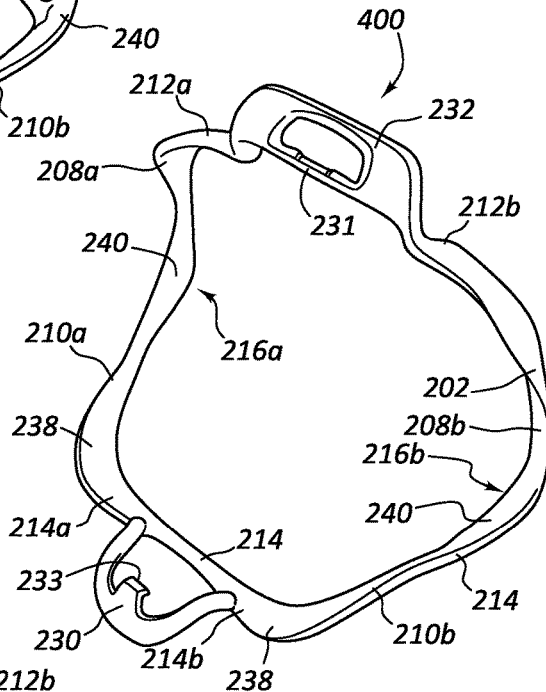

FIG. 11



**FIG. 12A**



**FIG. 12B**

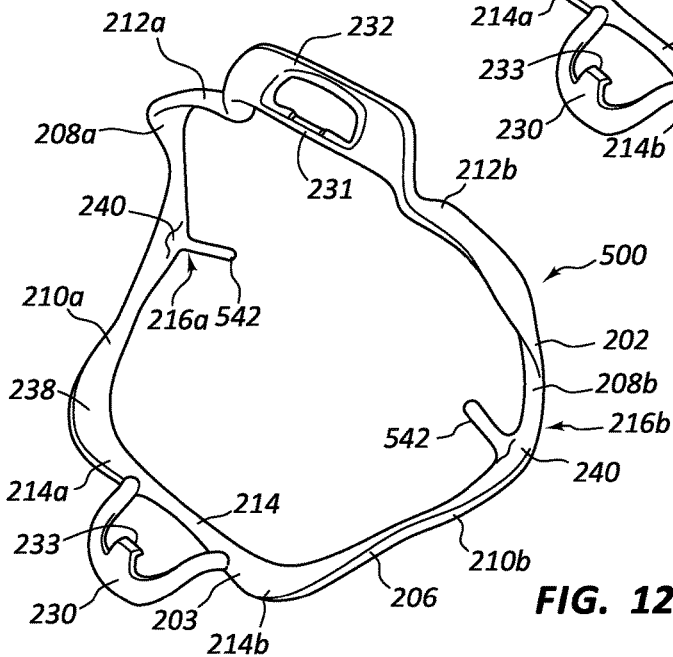

**FIG. 12C**

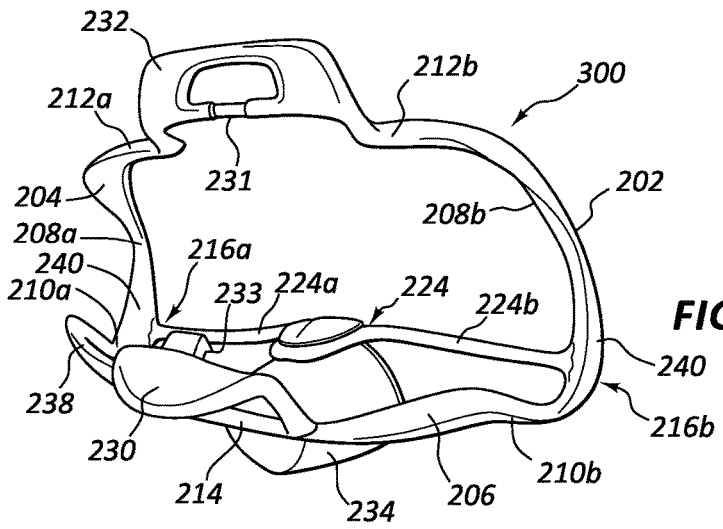

**FIG. 13A**

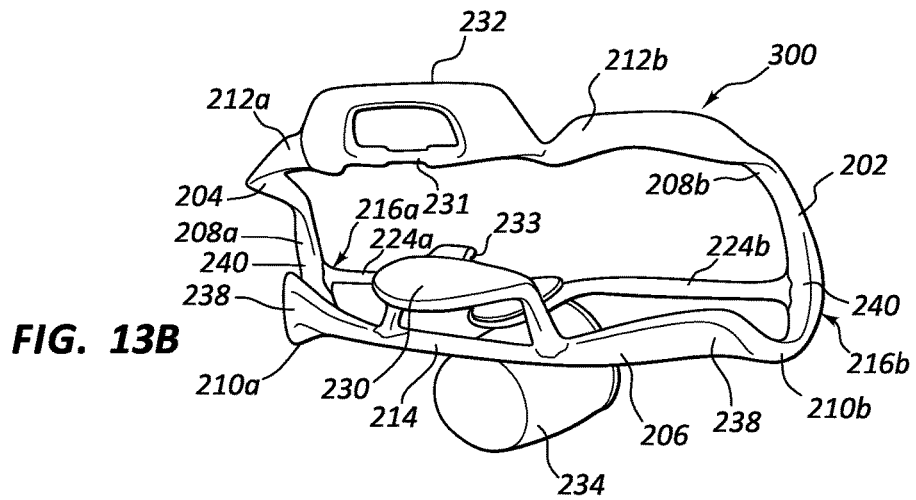

**FIG. 13B**

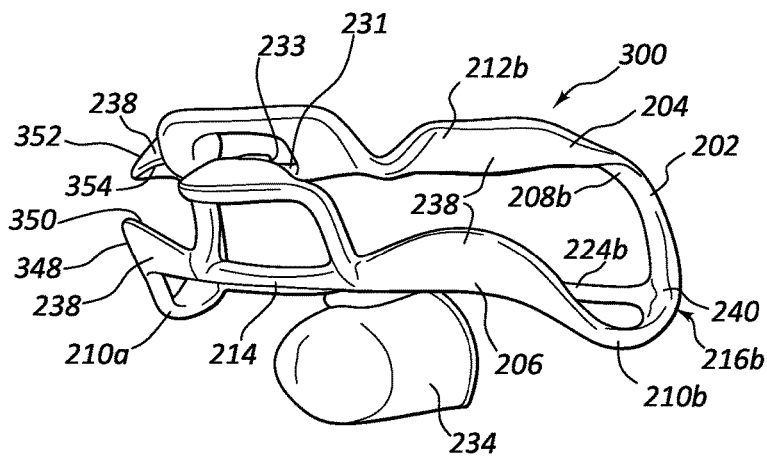

**FIG. 13C**

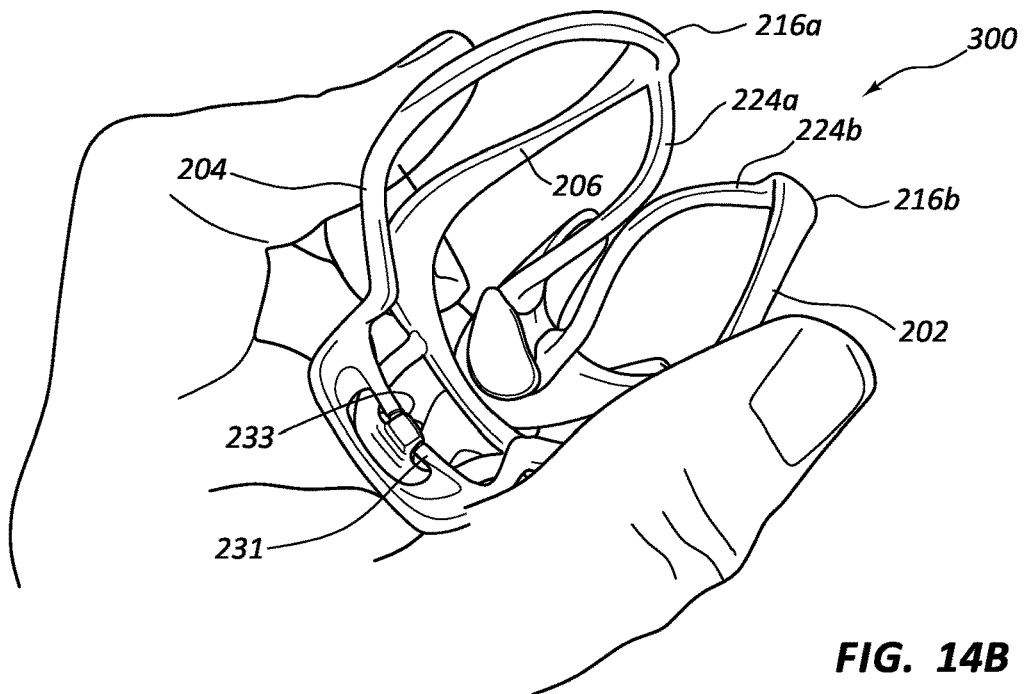
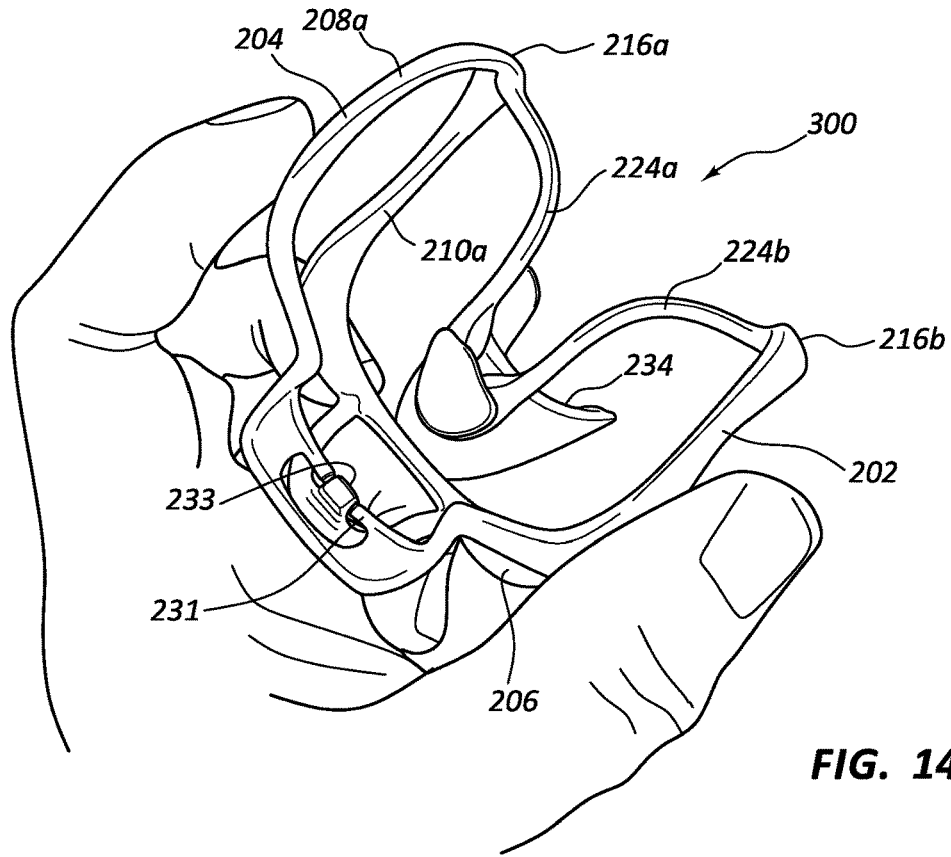



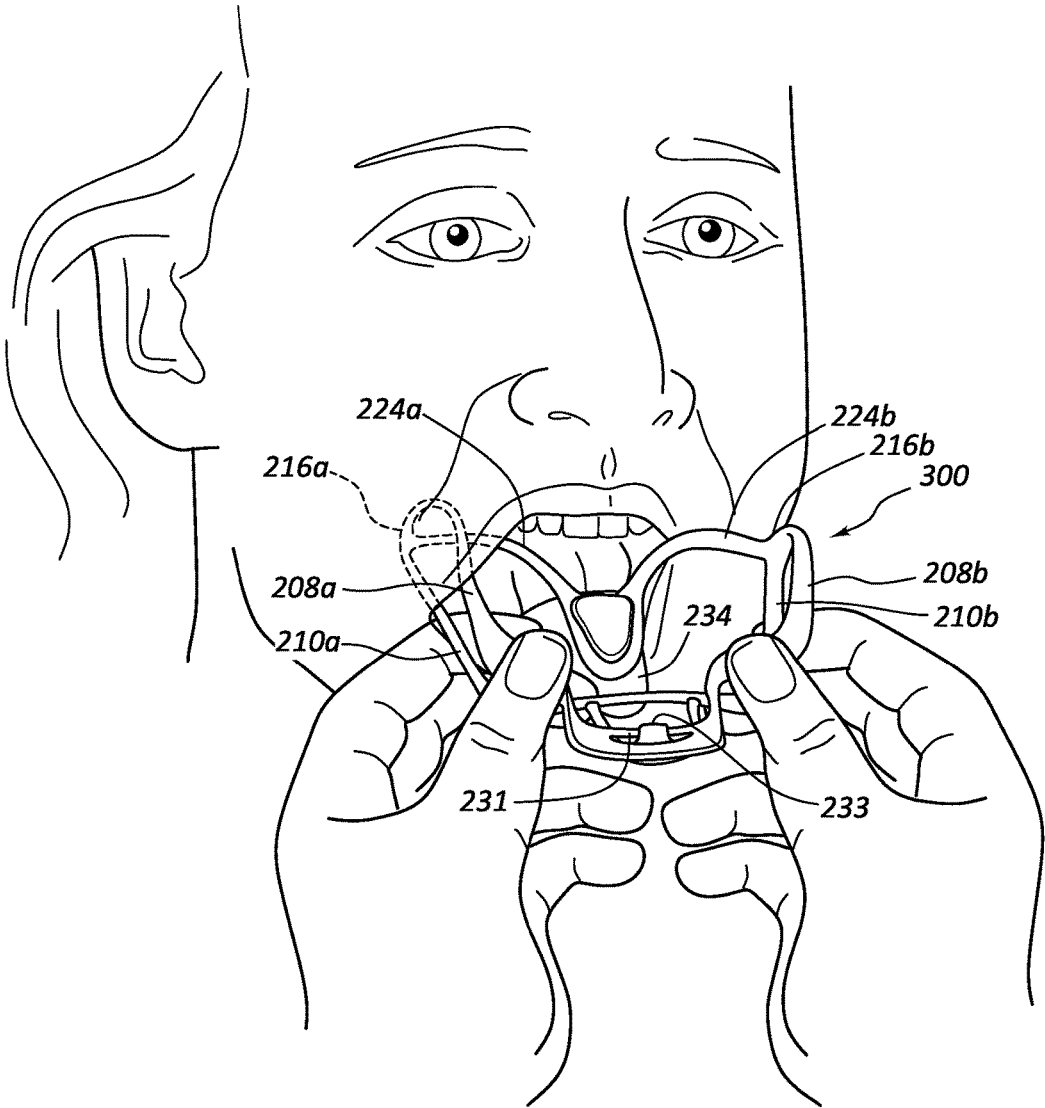

**FIG. 15A**

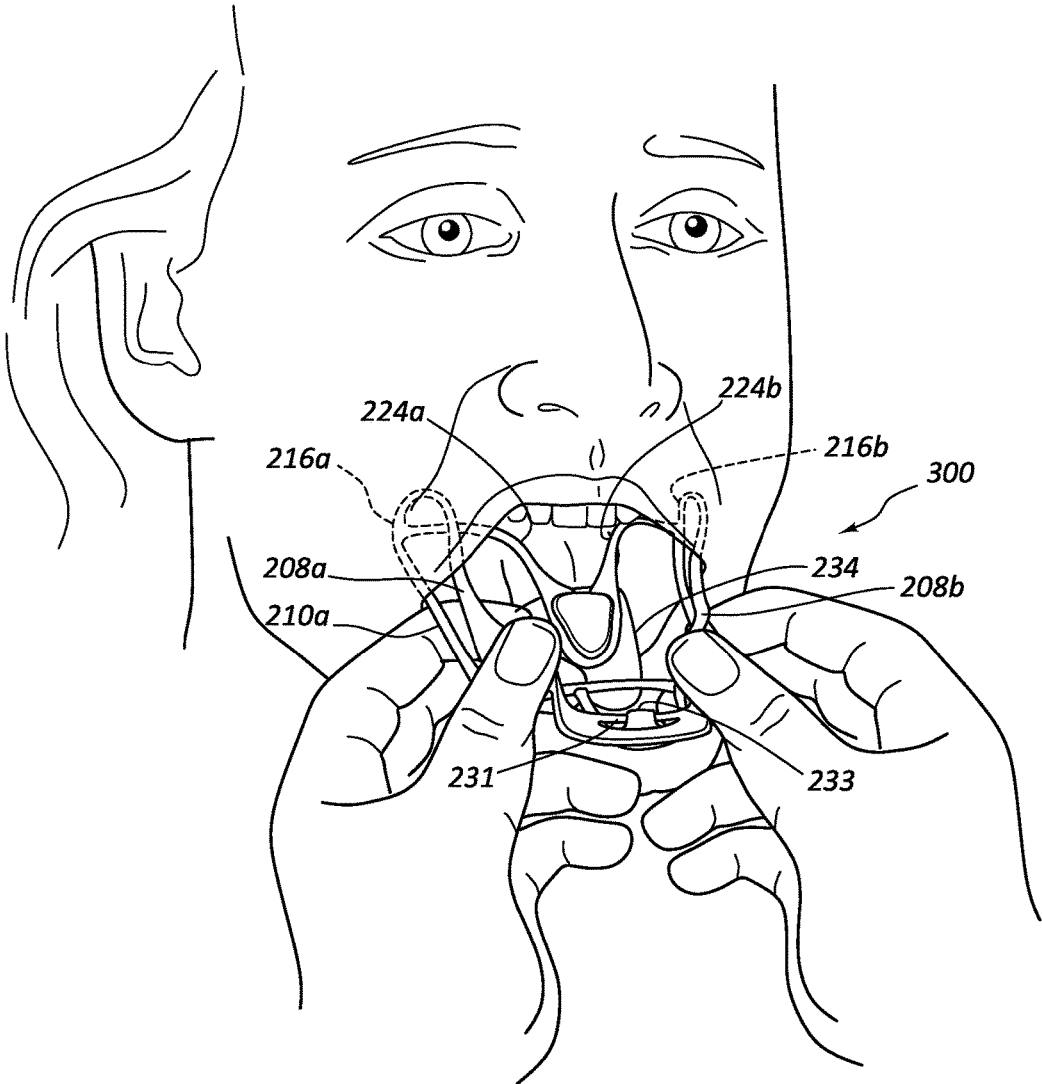

**FIG. 15B**

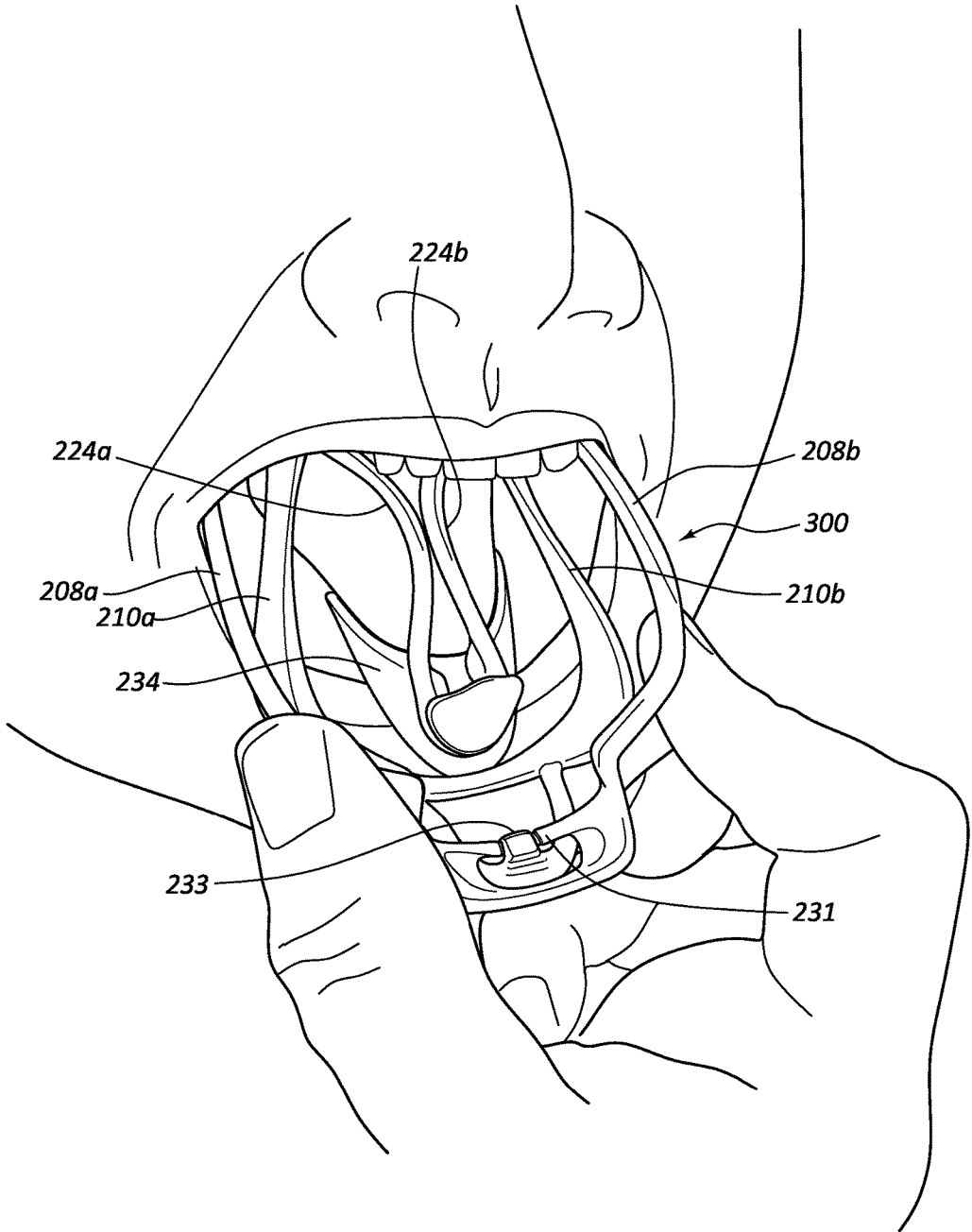
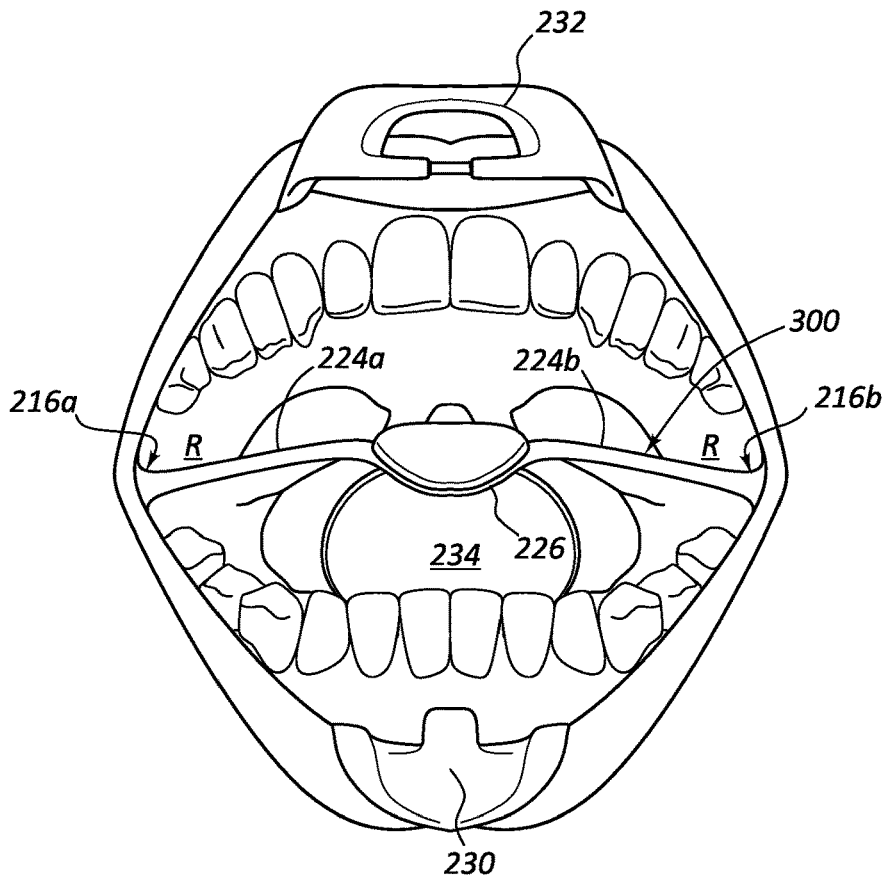
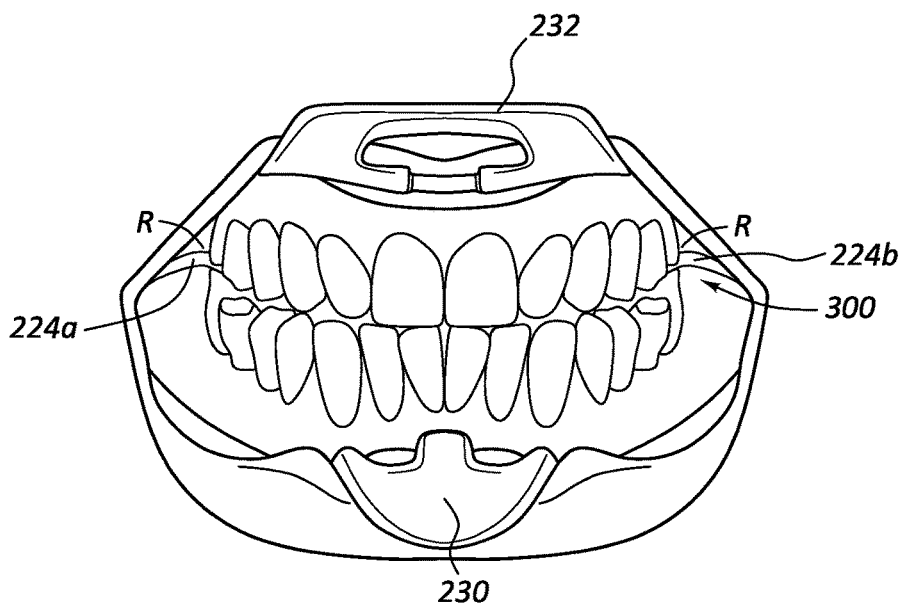

FIG. 16A



**FIG. 16B**



**FIG. 16C**

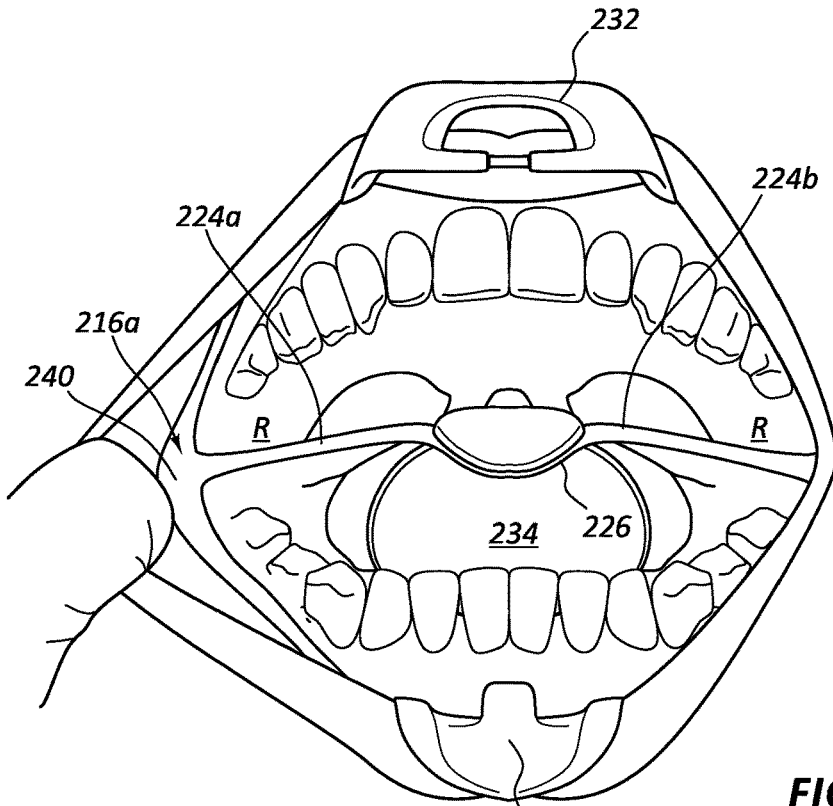

**FIG. 17A**

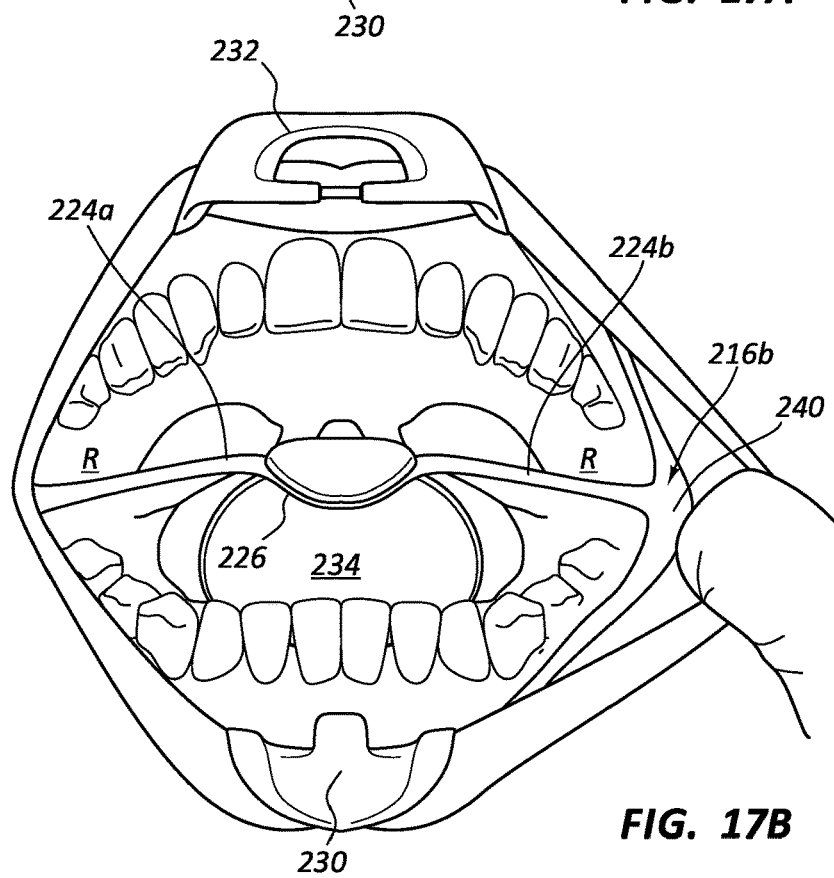

**FIG. 17B**

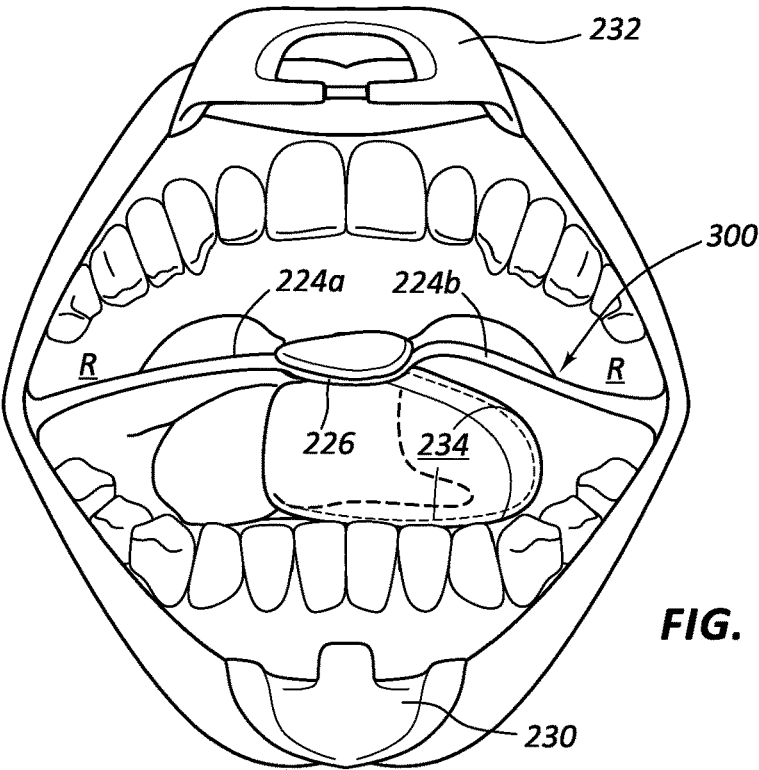

**FIG. 18A**

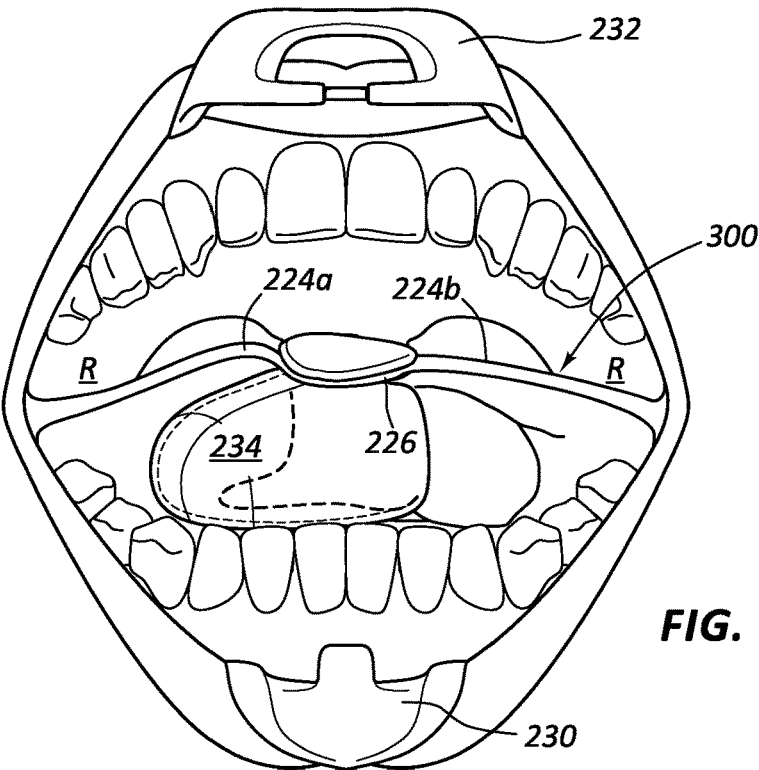

**FIG. 18B**



## CHEEK AND LIP EXPANSION DEVICE AND METHOD

### CROSS-REFERENCE TO RELATED APPLICATION

[0001] The present application is a continuation of U.S. patent application Ser. No. 14/858,954, filed Sep. 18, 2015 entitled CHEEK AND LIP EXPANSION DEVICE AND METHOD, which is a continuation-in-part of U.S. patent application Ser. No. 14/776,867, filed Sep. 15, 2015, entitled CHEEK RETRACTOR DEVICE AND METHOD”, which is a 35 U.S.C § 371 national stage application of PCT Application PCT/US14/28083, filed Mar. 14, 2014, entitled CHEEK RETRACTOR DEVICE AND METHOD” which claims the benefit of U.S. Provisional Patent Application Ser. No. 61/789,929, filed Mar. 15, 2013, entitled “CHEEK RETRACTOR DEVICE AND METHOD”. The disclosure of each of the foregoing is incorporated by reference in its entirety.

### BACKGROUND

#### 1. The Field of the Invention

[0002] The present invention is in the field of dentistry, particularly devices for isolating a patient’s teeth from soft oral tissue and enlarging the working field for the practitioner.

#### 2. The Relevant Technology

[0003] In certain procedures, particularly certain dental procedures, it can be helpful to retract soft oral tissue of the oral cavity from a patient’s teeth so as to create an enlarged working field around the teeth and dental arches. Various retraction devices exist, although these devices share certain problems. They are often difficult to insert and remove, often requiring extensive time to insert and causing discomfort to the patient during insertion and removal. They generally require that a dentist, dental assistant, or other practitioner use both hands to insert and remove the devices. They are generally uncomfortable to patients and can activate patient’s pharyngeal reflexes (i.e., gag reflex).

[0004] In some cases they simply stretch the lips apart without directly bearing against the cheeks. In such cases, they do not permit further manipulation of the patient’s lips or cheeks without causing pain. In other cases, they include bulky lip retraction structures that can block access to tooth surfaces along the sides of a dental arch. In still other cases, they are formed from rigid wires bent into a clam-shell structure that have little flexibility and which can exert significant pressure onto sensitive oral tissue, such as the sulcus between the gingiva and lips.

[0005] As such, it would be beneficial to provide a cheek and lip retraction or expansion device exhibiting improved characteristics.

### BRIEF SUMMARY

[0006] Disclosed herein are cheek and lip retraction or expansion devices for use in dental procedures or other procedures requiring access to the oral cavity with minimal obstruction. Various features are disclosed which may provide collapsibility, ability to latch in a collapsed configuration, and easier insertion into a patient’s mouth, (e.g., even allowing insertion with one hand). The device may include

structural and/or curvature characteristics which help “pull” the device into a patient’s mouth, facilitating easier insertion and maintenance within the mouth once installed.

[0007] In an aspect, the cheek and lip retraction or expansion device includes a frame that is flexible and resilient so as to be selectively collapsible and expandable to facilitate insertion into the mouth when in collapsed configuration and retraction or displacement of a person’s cheeks and lips from teeth of the upper and lower dental arches when in an expanded configuration. The expanded frame can comfortably bear against and inflate, displace, and/or flare outward the cheeks and lips to provide an opening effect (e.g., an umbrella- or tent-like effect). As used herein, the device may be interchangeably described as a retraction or expansion device. It will be appreciated that the device may tend to expand the cheeks and lips outward and forward (away from the dental arch and other surfaces they normally rest against), without uncomfortably retracting (really stretching) the lips side-to-side, which is what is accomplished by many existing devices.

[0008] The frame includes an upper frame portion configured to extend about a person’s upper dental arch, so as to bear against and retract soft oral tissue (e.g., cheeks and upper lip) from one or more teeth of the upper dental arch when the frame is in an expanded configuration. The frame also includes a lower frame portion configured to extend about a person’s lower dental arch, so as to bear against and retract soft oral tissue (e.g., cheeks and upper lip) from one or more teeth of the lower dental arch when the frame is in an expanded configuration. The upper frame portion includes first and second upper side members, each upper side member including a posterior region and an anterior region. An upper anterior connecting member is positioned between the anterior regions of the first and second upper side members. The lower frame portion similarly includes first and second lower side members, each lower side member including a posterior region and an anterior region. A lower anterior connecting member is positioned between the anterior regions of the first and second lower side members.

[0009] The upper side members of the upper frame portion are joined to corresponding lower side members of the lower frame portion at their posterior regions. For example, the first upper and lower side members can be joined on a left side of the frame, and the second upper and lower side members can be joined on a right side of the frame. In some embodiments, the upper and lower side members form a bendable radius in a posterior region of the frame that resists bending at a distinct point so as to create a larger bending radius where the bending moment is spread over a greater length along the upper and lower side members. The first upper and lower side members joined at their posterior regions form a first posterior arced region or joint (e.g., on the left side of the frame). The second upper and lower side members are similarly joined at their posterior regions to form a second posterior arced region or joint (e.g., on the right side of the frame). In some embodiments, the posterior regions of the side members can be thickened in the vicinity of the first and second posterior joints so as to resist bending at distinct points, resulting in bendable radii that spread bending forces out anteriorly towards the anterior ends of the respective side members. In another embodiment, mechanisms other than thickening could be employed to also resist bending (e.g., use of a different material, etc.)



Such a configuration permits the upper and lower frame portions to be at least partially collapsed or folded top to bottom, toward each other.

**[0010]** The frame also has a posterior width (e.g., between the first and second posterior joints) that is greater than either or both of the upper and lower anterior width dimensions. Such a configuration of greater posterior width than anterior widths helps to pull the device into the mouth, rather than push it out. By comparison, other cheek or lip retractors exhibit an oppositely configured wedge relationship where the anterior dimensions of the device are greater than the posterior dimensions. Such configurations exhibit a tendency to be easily pushed out of the oral cavity, rather than maintained in the desired position. In addition, they tend to stretch the lips to their greatest possible side-to-side extent, which is both uncomfortable for the patient and unhelpful to the practitioner, as it does not permit the practitioner any additional flexibility to pull one side of the lip (or both sides) to further expand the view and/or working field.

**[0011]** In some embodiments, the frame may further comprise a posterior crossbar positioned between (e.g., interconnecting) first and second posterior regions of the upper and lower frame portions. In some embodiments, the posterior crossbar interconnects the first and second posterior joints between the first and second upper and lower side members, respectively. The posterior crossbar is advantageously flexible and resilient to permit selective side-to-side collapse and expansion of the frame. In this way, the posterior crossbar can assist in providing an expansion force (e.g., in the x-axis direction) to the posterior arced regions of the upper and lower frame portions in order to retract cheeks from a patient's dental arches, particularly in the posterior region of the patient's mouth. The posterior crossbar may include first and second members having a posterior curvature, being joined at essentially a middle portion of the crossbar to create one or more preferential bending regions. The posterior crossbar can be configured and positioned so as to lie behind a person's posterior-most teeth (e.g., second molars in the case of an adult). In this configuration, the posterior crossbar does not extend and form a bridge across a patient's posterior teeth, which can otherwise obstruct and interfere with the ability of the patient to bite down and join occlusal surfaces of upper and lower posterior teeth. The posterior crossbar can also assist in retracting or expanding the patient's lips forward (e.g., anteriorly in the z-axis direction) and outwardly from anterior teeth (e.g., incisors and cuspids). It does this by interacting with (e.g., at least partially abutting posterior soft oral tissue associated with the mandibular ramus) to create posterior loading of the flexible spring-like frame to assist in flaring the cheeks and lips outwardly and away from adjacent posterior and anterior teeth of the upper and lower dental arches.

**[0012]** In some embodiments, where a posterior crossbar is provided, a selectively removable tongue guard may be provided that is selectively coupleable to the crossbar, to allow selective attachment or removal of the tongue guard, even with the device expanded, in the mouth.

**[0013]** In some embodiments, the upper frame portion can have an anterior width that is greater than an anterior width of the lower frame portion. For example, the upper anterior connecting member between the first and second upper side members can have a length that is greater than the length of the lower anterior connecting member between the first and second lower side members. This can help accommodate

differences between the size and anatomy of the upper and lower dental arches, and the associated vestibules between the dental arch and the cheek and/or lips into which the upper and lower frame portions are placed when the frame is expanded. For example, such a difference in upper and lower anterior widths better accommodates the anatomy into which the frame is placed, where the upper dental arch (and the associated upper anterior vestibule) is typically wider than the lower dental arch (and associated lower anterior vestibule).

**[0014]** In some embodiments, the cheek and lip retraction or expansion device may include an upper lip protecting member disposed on or forming part of the upper anterior connecting member of the upper frame portion and that is configured to extend away from an oral cavity and over an upper lip. A lower lip protecting member may similarly be disposed on or form part of the lower anterior connecting member of the lower frame portion in a manner to extend away from the oral cavity and over a lower lip. In some embodiments, the lip protecting members may be selectively engagable with one another (e.g., corresponding latching structure may be provided on each) when the upper frame portion is folded towards the lower frame portion so as to temporarily latch the upper and lower frame portions together. This can aid the practitioner and facilitate insertion of the retraction or expansion device using one hand. For example, latching the upper and lower members can free up a hand that might otherwise be required to collapse the upper and lower members together (e.g., in the y-axis direction) while using one hand to collapse the frame from side-to-side (e.g., in the x-axis direction).

**[0015]** These and other benefits, advantages and features of the present invention will become more fully apparent from the following description and appended claims, or may be learned by the practice of the invention as set forth hereinafter.

#### BRIEF DESCRIPTION OF THE DRAWINGS

**[0016]** To further clarify the above and other advantages and features of the present invention, a more particular description of the invention will be rendered by references to specific embodiments thereof, which are illustrated in the appended drawings. It is appreciated that these drawings depict only typical embodiments of the invention and are therefore not to be considered limiting of its scope. The invention will be described and explained with additional specificity and detail through the use of the accompanying drawings in which:

**[0017]** FIG. 1 is an anterior view of an exemplary expanded cheek and lip expansion device.

**[0018]** FIG. 2 is a front perspective view of the cheek and lip expansion device of FIG. 1.

**[0019]** FIG. 3 is a side view of the cheek and lip expansion device of FIG. 1, with the upper frame portion also shown in broken lines indicating how it may be folded and latched with the lower frame portion.

**[0020]** FIG. 4 is a posterior or rear perspective view of the cheek and lip expansion device of FIG. 1.

**[0021]** FIG. 5 is an anterior or front view of the cheek and lip expansion device of FIG. 1 installed within the oral cavity of a patient.

**[0022]** FIG. 6 is an anterior or front view of an alternative exemplary expanded cheek and lip expansion device.

[0023] FIG. 7 is a front perspective view of the cheek and lip expansion device of FIG. 6.

[0024] FIG. 8 is a side view of the cheek and lip expansion device of FIG. 6, with the upper frame portion also shown in broken lines indicating how it may be folded and latched with the lower frame portion.

[0025] FIG. 9 is a posterior or rear perspective view of the cheek and lip expansion device of FIG. 6.

[0026] FIG. 10A is an anterior or front view of the cheek and lip expansion device of FIG. 6 installed within the oral cavity of a patient.

[0027] FIG. 10B-10C are side profile views showing the patient's mouth without the expansion device installed (FIG. 10B) and with the expansion device installed and expanded (FIG. 10C), showing how the upper and lower lips are inflated, displaced and flared forward, in the z-axis direction.

[0028] FIG. 11 is a perspective view of the cheek and lip expansion device of FIG. 6, with the tongue guard shown separated from the cheek expansion device.

[0029] FIG. 12A is a front perspective view of another exemplary expanded cheek and lip expansion device.

[0030] FIG. 12B is a front perspective view of a cheek and lip expansion device similar to that of FIG. 12A, but without any posterior crossbar.

[0031] FIG. 12C is a front perspective view of a cheek and lip expansion device similar to that of FIG. 12A, without the posterior crossbar connecting posterior regions of the first and second upper and lower side members, but still including inwardly protruding extensions (e.g., a portion of the crossbar), to aid in loading the device against soft tissue covering the mandibular ramus.

[0032] FIG. 13A shows the device of FIG. 12A, with the frame partially collapsed from top to bottom.

[0033] FIG. 13B shows the device of FIG. 13A, showing a greater degree of collapse from top to bottom.

[0034] FIG. 13C shows the device of FIG. 13A, showing full collapse of the frame from top to bottom, with the lower frame portion latched to the upper frame portion.

[0035] FIG. 14A shows the device of FIG. 12A, with the frame partially collapsed from side-to-side.

[0036] FIG. 14B shows the device of FIG. 14A, with the frame further collapsed from side-to-side.

[0037] FIGS. 15A-15B show how the device of FIG. 12A may be placed into a person's mouth using the top to bottom collapsibility of the device, with little or no reliance on the side-to-side collapsibility of the device. FIG. 15A shows one side of the device of FIG. 12A being placed (e.g., shoe-horned) into a person's mouth.

[0038] FIG. 15B is a progression from the state shown in FIG. 15A, showing the other side of the frame being positioned into the person's mouth.

[0039] FIG. 16A shows how the device of FIG. 12A may be placed into a person's mouth using both the top to bottom and side-to-side collapsibility of the device. In FIG. 16A, the upper and lower frame portions have been collapsed and latched together, and the posterior arced regions pressed together, collapsing the device side-to-side, as well as top to bottom.

[0040] FIG. 16B shows the device of FIG. 12A in the mouth, with the mouth open, e.g., as placed using either the method of FIGS. 15A-15B or that of FIG. 16A.

[0041] FIG. 16C is similar to that of FIG. 16B, but showing the person's jaw being closed, with the device in the mouth.

[0042] FIGS. 17A and 17B illustrate how, with the cheek and lip expansion device in the mouth, the lips are not fully stretched side-to-side around the mouth, which permits asymmetric deformation of the person's lips to one side or the other without excessively stretching the lips and causing pain to the patient.

[0043] FIGS. 18A-18D show how with the cheek and lip expansion device in the mouth and the distal tip of the patient's tongue in the tongue guard, the patient is able to still move their tongue to either side, up, and down.

## DETAILED DESCRIPTION

### I. Introduction

[0044] The invention generally relates to intra-oral cheek and lip expansion devices useful for expansion of soft oral tissues away from the dental arches, isolating one or more teeth from soft oral tissue and creating an enlarged working field. Such cheek and lip expansion devices may include a selectively collapsible and expandable flexible and resilient (e.g., spring-like) frame for insertion into an oral cavity. The collapsed configuration facilitates insertion into the mouth, while the expanded configuration, while positioned in the mouth, allows the frame to bear against and retract or displace soft oral tissue in multiple dimensions and thereby isolate one or more teeth from soft oral tissue and create an enlarged working field. For example, rather than moving the mandible down, the cheeks and lips may be displaced outward and forward in order to enlarge the working field, increasing space for the practitioner to work and/or visualize the teeth, gums, or other structure.

[0045] The frame may include an upper frame portion and a lower frame portion, which are advantageously flexible and resilient (e.g., spring-like) so as to selectively assume collapsed and expanded configurations during installation and use, as discussed more fully below. The flexibility of the upper and lower frame portions permits them to be selectively collapsed in a side-to-side (e.g., x-axis) direction and also an up-and-down (e.g., y-axis) direction to facilitate insertion of the frame, when in a collapsed configuration, into the oral cavity of a patient. After installation, the resiliency of the upper and lower frame portions causes them to expand outwardly in a spring-like fashion in at least x-axis and y-axis directions to assume an expanded configuration inside the patient's oral cavity. The expanded frame inflates the patient's mouth (e.g., like a tent or umbrella), displacing, comfortably flaring, and retracting the cheeks and lips away from teeth of the upper and lower dental arches. Posterior loading, such as by abutment of a posterior regions of the frame against a posterior region of the patient's mouth, may cause the frame to also exert force in a forward (or z-axis) direction in order to retract the patient's lips away from teeth in the forward direction. In this way, the expansion device can create an enlarged and unobstructed working field in the oral cavity by retracting the cheeks and lips from a patient's teeth in a comfortable, umbrella-like fashion, instead of unnecessarily, excessively, and uncomfortably stretching the lips too far in a side-to-side (x-axis) direction, as typically occurs with prior lip retraction devices.

### II. Exemplary Cheek and Lip Expansion Devices

[0046] FIGS. 1 through 5 illustrate an exemplary cheek and lip expansion device 100. FIG. 1, for example, shows a

cheek and lip expansion device **100** comprising a frame **102** for insertion into an oral cavity (oral cavity and mouth may generally be interchangeably used herein). Frame **102** further includes an upper frame portion **104** and a lower frame portion **106**, which are advantageously flexible and resilient so as to selectively assume collapsed and expanded configurations during installation and use. In a collapsed configuration (e.g., see FIG. 3 and FIGS. 13A-14B), device **100** is more easily inserted into the oral cavity, while the expanded configuration (e.g., see FIG. 5) allows upper and lower frame portions **104**, **106** to extend about the upper and lower dental arches, respectively, and to bear against and retract soft oral tissue from adjacent teeth in multiple dimensions (e.g., in each of x-axis, y-axis, and z-axis directions) to create an enlarged working field for the practitioner. Absent applied forces (or engagement of an optional latching mechanism discussed below), frame **102** may assume the expanded configuration seen in FIGS. 1-4. The expanded frame **102** inflates or dilates the patient's mouth, displacing, flaring, and retracting tissue including the cheeks and lips away from the jaw and the teeth of the upper and lower dental arches. Posterior loading, such as by abutment of a posterior end of frame **102** against a posterior region of the patient's mouth, causes frame **102** to also exert force in a forward (or z-axis) direction in order to retract the patient's lips away from teeth in the forward direction.

[0047] As further illustrated in FIG. 1, upper frame portion **104** includes upper side members **108**, including a first (e.g., left) upper side member **108a** and a second (e.g., right) upper side member **108b**. Similarly, lower frame portion **106** includes lower side members **110**, including a first (e.g., left) lower side member **110a** and a second (e.g., right) lower side member **110b**. References to "left" and "right" are made from the perspective of the practitioner facing the patient, although it is to be understood that the designation is arbitrary; the frame of reference could alternatively be made from the perspective of the patient line of sight (i.e., right becomes left and vice versa).

[0048] The upper side members **108** and lower side members **110** extend from arced regions **116a** and **116b**. The first upper and lower side members **108a**, **110a** may be joined at a first posterior frame region **116a**, and the second upper and lower side members **108b**, **110b** may be joined at a second posterior frame arced region **116b**. Posterior frame arced regions **116** may form flexible yet sufficiently rigid joints that resist bending at a single point but rather distribute the bending radius along a substantial length of upper and lower side members **108**, **110** when upper and lower frame portions **104**, **106** are collapsed together. This in turn distributes opening forces along a substantial portion of the length of each side member in order to bear against and effectively retract soft oral tissues from the patient's teeth in both posterior and anterior regions of the mouth. In another embodiment, a posterior hinge may be provided that enables articulation between the upper and lower side members **108** and **110**.

[0049] In some embodiments, posterior frame arced regions **116** may each form a curved, bowed, v-shaped or u-shaped posterior joint on either side of frame **102**. While posterior frame arced regions **116** may be generally described as forming "v-shaped" or "u-shaped" posterior joints, these terms are to be construed broadly. For example, any acute angular relationship between upper and lower side members **108**, **110** may be considered to be v-shaped or

u-shaped. In addition, even if the angular relationship between upper and lower side members **108**, **110** were technically obtuse rather than acute, the terms "v-shaped" and "u-shaped" may be used to broadly encompass any such configurations so long as the radius of curvature between upper and lower side members **108**, **110** is smaller at the posterior end or region of frame **102** compared to the anterior end or region. In some embodiments, posterior frame arced regions **116** may represent the posterior most portions of upper and lower frame portions **104**, **106**.

[0050] The upper frame portion **104** may include an upper anterior connecting member **112**, which may be disposed between anterior regions of first and second upper side members **108a**, **108b** and which may include a first upper connecting portion **112a** adjacent to first upper side member **108a** and a second upper connecting portion **112b** adjacent to second upper side member **108b**. Similarly, the lower frame portion **106** may include a lower anterior connecting member **114**, which may be disposed between anterior regions of the first and second lower side members **110a**, **110b** and which may include a first lower connecting portion **114a** and a second lower connecting portion **114b**.

[0051] The distance between a central point, apex or posterior-most region of the first and second posterior frame arced regions **116a**, **116b** defines a posterior width **120** of frame **120**. The distance between anterior-most regions of first and second upper side members **108a**, **108b** of upper frame portion **104** defines an upper anterior width **122**. The distance between the anterior-most region of first and second lower side members **110a**, **110b** of lower frame portion **106** defines a lower anterior width **122'**. In some embodiments, the posterior width **120** of frame **102** as defined between upper and lower side members **108**, **110** adjacent posterior frame ends **116** (e.g., the distance between the vertex of angled first posterior frame end or joint **116a** to the vertex of angled second posterior frame end or joint **116b**) is greater than the upper and lower anterior widths **122**, **122'** of upper and lower frame portions **104**, **106**.

[0052] In some embodiments, the upper and lower anterior widths **122**, **122'** of upper and lower frame portions **104**, **106**, respectively, can also differ from one another. In some embodiments, the upper anterior width **122** of upper frame portion **104** can be greater than the lower anterior width **122'** of lower frame portion **106**, such as to account for anatomical differences in size between a patient's upper and lower dental arches, with the upper dental arch typically being wider and encompassing or surrounding the lower dental arch in the anterior region when the teeth are brought together, with the upper incisors and cuspids generally extending over and forward of the lower incisors and cuspids.

[0053] Expansion device **100** may be designed to have different sizes depending on the facial anatomy of the patient (which may be determined, for example, by the spacing between the eyes and/or whether the patient is a small child, growing child, or adult). In some embodiments, expansion device **100** may have a posterior width **120** in a range of about 90-130 mm (e.g., about 95-110 mm, about 100 mm, or about 115-120 mm) and anterior widths **122**, **122'** in a range of about 50-90 mm. For example, the upper anterior width **122** of upper anterior connecting member **112** may be in a range of about 70-90 mm. Where the lower anterior width **122'** of lower anterior connecting member **114** is less than the upper anterior width **122** of upper anterior connecting

member **112**, it may be in a range of about 50-90 mm. In some embodiments, the posterior width **120** may be from about 20% to about 100%, from about 20% to about 80%, from about 25% to about 75%, or from about 30% to about 50% (e.g., about 40%-50%) greater than either the upper or lower anterior widths **122**, **122'**. In some embodiments, the posterior width **120** can be greater than the upper anterior width **122**, which may be greater than the lower anterior width **122'**. By way of example, with a posterior width of about 100 mm, an upper anterior width of about 70 mm, and a lower anterior width of about 50-55 mm, the posterior width **120** is about 40% greater than the upper anterior width **122**, and about 90-100% greater than the lower anterior width **122'**. The upper anterior width **122** may in turn be from about 15% to about 80%, from about 25% to about 75%, or from about 30% to about 50% (e.g., about 40%) greater than the lower anterior width **122'**. Providing a greater upper anterior width **122** as compared to lower anterior width **122'** better conforms to the actual anatomy of a typical patient, as the upper dental arch is typically wider across its anterior region than the lower dental arch. This configuration provides better comfort and a better fit as upper and lower connecting members **112**, **114** are received within corresponding upper and lower anterior vestibules of the mouth.

**[0054]** In addition, a larger posterior width **120** advantageously provides a configuration by which expansion device **100** tends to pull itself into the patient's mouth and be retained therein, as opposed to exhibiting a tendency for a cheek or lip retractor to be pushed out of the patient's mouth, which is typical of many existing devices. In addition, this feature helps improve the ease of insertion of expansion device **100**, particularly in combination with the side-to-side collapsibility that may be provided by the flexible and resilient spring-like frame **102**. For example, the posterior width **120** can be collapsed side-to-side to have a width that is less than anterior widths **122**, **122'** during insertion, if desired (see FIGS. **14B** and **16A**), and then the posterior width **120** expands once released within the mouth, helping to pull the device back into the mouth, and to maintain it there so long as desired.

**[0055]** In addition to or instead of the upper anterior width **122** being greater than the lower anterior width **122'**, the total length of upper frame portion **104** can be greater than the total length of lower frame portion **106**. In some embodiments, the total length of upper frame portion **104** is the combined lengths of first and second upper side members **108** and upper anterior connecting member **112**, and the total length of lower frame portion **106** is the combined lengths of first and second lower side members **110** and lower anterior connecting member **114**. The overall lengths of upper and lower frame portions are shown in FIG. **6**, which shows another embodiment of a cheek and lip expansion device. The overall length of the upper frame portion is designated  $L_U$ , while the overall length of the lower frame portion is designated  $L_L$ . Differences in length between upper and lower frame portions **104**, **106** can account for anatomical differences in length and size between the upper and lower dental arches of a patient, and the associated upper and lower vestibules of a typical patient. Many existing cheek or lip retraction devices do not account for such differences, but rather mirror the bottom half of the device relative to the top half, which decreases both effectiveness and comfort.

**[0056]** To further account for anatomical differences between upper and lower dental arches, side members **108**, **110** of upper and lower frame portions **104**, **106** may differ from one another in length. For example, side members **108** of upper frame portion **104** may be somewhat shorter or longer than side members **110** of lower frame portion **106**. For example, upper side members **108** may be shorter than lower side members **110**, although upper frame portion **104** may have an anterior width **122** and overall length that are greater than the anterior width **122'** and overall length of lower frame portion **106**, as described above. All such characteristics may be provided to better fit the anatomy of the upper and lower dental arches and associated upper and lower vestibules into which the upper and lower frame portions are received. They can be customized based on differences in anatomy, size, age, gender, and the like.

**[0057]** As illustrated in FIG. **1**, frame **102** may include a posterior crossbar **124** positioned between first and second posterior ends **116a**, **116b**. In some embodiments, the crossbar **124** may include first and second posteriorly curved portions **124a**, **124b**. Posterior crossbar **124** may include a curved, bowed, v-shaped or u-shaped anteriorly curved portion **126** (e.g., centrally located along posterior crossbar **124** between the first and second curved portions **124a**, **124b**, if present). Each of the posteriorly curved portions **124a**, **124b** and the anteriorly curved portion **126** may increase flexibility and resilience of the posterior crossbar **124** to better facilitate side-to-side collapse of frame **102** (e.g., by moving first and second posterior ends **116a**, **116b** toward each other). Thus, frame **102** may be collapsible in a side-to-side dimension (e.g., x-axis direction) as well as a top-to-bottom dimension (e.g., y-axis direction). Such multi-dimensional collapsibility greatly improves the ease of insertion, facilitating single-handed insertion and installation in a patient's mouth. Single-handed insertion can be further facilitated by providing a latch mechanism, which can latch upper and lower frame portions **104**, **106** together, as described in further detail below. A latch mechanism could also be provided for holding frame **102** in a side-to-side collapsed configuration if desired. Such collapsed configuration is described in further detail in conjunction with FIGS. **13A-14B**.

**[0058]** In an embodiment, posterior crossbar **124** may be connected to either side of upper frame portion **104** and lower frame portion **106** by first and second floating gussets **128a**, **128b**, which provide a pair of connections bridging first and second posterior ends or joints **116a**, **116b**. For example, second floating gusset **128a** may connect with right upper side member **108b** at upper connection point or region **129a** and with right lower side member **110b** at lower connection point or region **129b**. First floating gusset **128a** may be similarly connected with upper and lower side members **108a**, **110a**. Floating gussets **128** may provide additional rigidity that increases upward, opening curvature or force to frame **102**, resists collapse, and directs applied collapsing forces away from (or anterior to) posterior ends or joints **116** and toward connection points or regions **129a**, **129b** on each side of the floating gusset. Such structure may direct bending of upper and lower frame portions **104**, **106** as they are selectively collapsed or expanded in a top to bottom dimension (e.g., y-axis direction). Floating gussets **128** may also facilitate easier side-to-side collapsibility when applying side-to-side forces, as posterior crossbar **124** is not directly connected to upper and lower frames **104**, **106**

at posterior ends **116** but at points spaced apart from the apex or vertex of posterior ends **116**.

**[0059]** Upper and lower frame portions **104**, **106** may further include upper and lower lip protecting members **130** and **132**, respectively. Upper lip protecting member **130** may be centrally disposed on or in upper anterior connection member **112** (e.g., between first upper connecting portion **112a** and second upper connecting portion **112b**) and extend laterally forward from upper frame portion **104** in order for upper lip protecting member **130** to extend away from the patient's oral cavity and over the patient's upper lip during use. Lower lip protecting member **132** may be similarly disposed along lower anterior connection member **114** or lower frame portion **106** so as to extend away from the patient's oral cavity and over the patient's lower lip during use.

**[0060]** Upper and lower lip protecting members **130**, **132** may curve over and protect the central portion of a patient's upper and lower lips during a dental procedure. In addition, as perhaps best seen in FIG. 1, lip protecting members **130** and **132** may provide recesses or troughs **105a** and **105b** above and below generally horizontal anterior lines defined by anterior connecting members **112**, **114** of upper and lower frame portions **104**, **106**, respectively. Such troughs can be designed to further enlarge the working field available to the practitioner in the region of the patient's upper and/or lower incisors, while at the same time covering and protecting the central portion of the patient's lips. In at least the case of the upper recess or trough **105a**, it may also avoid irritating contact with the bony structure in the central portion of the upper vestibule where the recess **105a** is disposed when in the mouth. In an embodiment, lip protecting members **130**, **132** may be made from a stiffer material than other frame portions of device **100**, which are relatively flexible and resilient. In addition to the benefits described above, lip protection members **130** and **132** may also serve as an emergency removal handle should the device need to be removed quickly. Even where quick removal may not be needed, lip protection members may present a portion of structure **100** that may be easily and readily grasped by the practitioner when the device is to be removed. Advantageously, these members may be the only structure protruding from the person's mouth during use, with the lip protection members covering the central portion of the person's upper and lower lips, rather than the sides thereof, so as to not unnecessarily stretch the patient's lips open from side-to-side to the extent that many other retraction devices do.

**[0061]** Furthermore, as perhaps best seen in FIG. 3, lip protecting members **130**, **132** may be selectively engagable with one another when upper frame portion **104** is folded towards lower frame portion **106** so as to latch upper **104** and lower **106** frame portions together. Of course, while sometimes described herein in terms of upper frame portion **104** being folded downward towards lower frame portion **106**, it will be understood that one or both frame portions may move during such collapse so that lower frame portion **106** may similarly be collapsed toward upper frame portion **104**.

**[0062]** An example of such folding and latching is illustrated in FIG. 3, where the expansion device is shown both before folding (in solid lines), and after folding (with the upper frame portion **104** shown again in broken lines). FIGS. 13A-13C, described in further detail below, further illustrate top to bottom collapse of another similar cheek and

lip expansion device. Such a latching mechanism may be used to lock upper and lower frame portions **104**, **106** in a closed, collapsed configuration prior to insertion into the patient's mouth. As a result of the device being latched in a configuration where it is collapsed in the upper-to-lower dimension, the practitioner is not required to hold the device in this collapsed configuration (it may be maintained until released), allowing the practitioner to more easily configure and hold the device in a side-to-side collapsed configuration during insertion. Such methods of insertion are described in further detail below in conjunction with FIGS. 15A-16B.

**[0063]** Once cheek and lip expansion device **100** is inserted into the patient's mouth, the latch mechanism may be released to allow frame **102** to expand within the patient's mouth. For example, if upper **104** and lower **106** frame portions are latched together, a practitioner may use one hand to squeeze posterior sides of frame **102** together in a side-to-side manner, and insertion may be easily done with one hand, if such insertion is desired. Of course, two-handed insertion is also possible. Different mechanisms for latching upper and lower frame portions **104**, **106** (e.g., a latch structure separate from any lip protection members) may alternatively or additionally be provided. Such additional latch structure could also be provided for latching any side-to-side collapse of any of the devices disclosed herein, as well. Some such latching mechanisms are described in further detail in conjunction with the embodiments of FIGS. 6-16B, below.

**[0064]** Expansion device **100** may also include a tongue guard **134**, which may be selectively removable. For example, this may allow attachment or removal of tongue guard **134** from posterior crossbar **124**, even while expansion device **100** is installed within an oral cavity of a patient. While tongue guard **134** may be removed while device **100** is installed within an oral cavity of a patient, it may also be removed prior to insertion, after insertion or removal, or at any point in the procedure. Tongue guard **134** may be coupleable to posterior crossbar **124** through any suitable mechanism (e.g., friction fit, press-fit, keyed coupling, etc.). For example, a protrusion and receptacle configuration shared between tongue guard and posterior crossbar **124** may allow tongue guard **134** to "click" into place once seated.

**[0065]** Tongue guard **134** may serve to prevent activation of a patient's pharyngeal reflexes (i.e., gag reflex) and to prevent the flow of saliva. In some patients with a sensitive or "strong" pharyngeal reflex, it may be desirable to remove tongue guard **134** from the expansion device **100**. A removable tongue guard **134** permits expansion device **100** to be used with or without tongue guard **134**, depending on patient need or preference. In an embodiment, aspiration may be provided through tongue guard **134** (e.g., it may include perforations or holes formed therethrough). Tongue guard **134** may be formed of the same or a different material than other portions of expansion device **100**. For example, a material that is particularly flexible, soft and adaptable (e.g., silicone or a thermoplastic elastomer) may be preferred. While tongue guard **134** is shown as a simple stop against which the tongue may press, in other embodiments, the tongue guard may partially or substantially fully encapsulate or envelop at least a portion of the tongue, such as the distal end of the tongue. Examples of such tongue guards (e.g., tongue guard **234**) are described in further detail below, in conjunction with FIGS. 6-16B. The tongue guard may

advantageously be supported on posterior crossbar **124** in a manner that permits it to move somewhat up, down, or from side-to-side (e.g., to allow the patient some ability to move the tongue during a procedure). A tongue guard and the central portions of crossbar **124** (e.g., anteriorly curved portion **126**) may push forward as device **100** is collapsed side-to-side, as apparent in FIGS. **14A-14B**. Upon relaxation of such a side-to-side collapsing force, the tongue guard and central portions of cross bar **124** may again move backward (posteriorly) as frame **102** is expanded.

[**0066**] As well illustrated in FIGS. **2** and **3**, expansion device **100** may also include one or more bumpers or enlarged, thickened portions **138** on frame **102**, positioned for receipt into the anterior corners of the upper and lower vestibules (e.g., the area between the teeth and dental arch lips, and cheeks) at anterior corners of the upper and lower frame members. Such bumpers **138** may also provide increased surface area to which a cushioning material may be applied (e.g., a cover over the bumpers), to provide additional cushioning to specific areas of the mouth. The embodiment of FIG. **6** illustrates such bumper covers **238'** over the bumpers. For example, a pair of anterior thickened bumpers **138** on each of upper and lower frame portions **104**, **106** may be provided at anterior corners where side members **108**, **110** intersect with anterior connecting members **112**, **114**. In addition, left and right side members **108a**, **108b** may be thickened in various regions, such as adjacent to posterior ends **116** to form thickened posterior regions **140**. Bumpers **138** and thickened posterior regions **140** may comprise enlarged, thickened portions of frame **102** as compared to adjacent portions of frame **102**, to increase surface area contact with soft tissues in these regions, providing increased comfort as bumpers **138** bear against soft oral tissue. The thickened characteristics of the these thickened regions may also increase their rigidity and resistance to bending as compared to adjacent, thinner regions of the frame. Such increased rigidity aids in lip lifting and retraction or expansion, forcing the lips to flare upwardly and forwardly.

[**0067**] Thickened regions **140** at posterior ends **116** may resist bending at a distinct point of posterior ends or joints **116**, so as to form a bendable radius that resists bending at a single distinct point, but rather distributes the bending forces anteriorly, along the length of the side members **108**, **110**. Some bending forces may also be distributed to regions near or adjacent to upper and lower anterior connecting members **112**, **114**. Such bending forces may particularly cause bending to occur at more anterior, thinner portions of the side members **108**, **110** (e.g., within the thinner central portions of side members **108** and **110**) during top to bottom collapse. Bumpers **138** and/or thickened posterior regions **140** at posterior ends **116** may also provide improved access to the oral cavity by the practitioner, better holding back adjacent soft tissue. During use, first and second lower side members **110a**, **110b** of lower frame portion **106** may reside within the lower facial vestibule, and first and second upper side members **108a**, **108b** of upper frame portion **104** may reside within the upper facial vestibule. Upper and lower anterior connecting members **112**, **114** may reside within the upper and lower anterior vestibules, respectively. Thickened posterior regions **140** may bear against the rear of the facial vestibules, pushing the device forward, with thickened bumpers **138** residing in the corners at the transitions between the facial portion and anterior portion of the upper and lower

vestibules. Such bumpers **138** may aid in holding the soft tissues back from the teeth, and flaring the lips and cheeks forward and outwardly.

[**0068**] Anterior bumpers **138** may be located at or near anterior corners of upper and lower frame portions **104**, **106** so that upper and lower anterior bumpers **138** serve to cushion the anterior cheek soft tissue adjacent the corners of the patient's mouth. The thickened posterior regions **140** similarly cushion the posterior cheek soft tissue towards the back of the patient's mouth, adjacent the jaw, backwall of the vestibule, and the ramus.

[**0069**] Many existing retraction devices tend to "grab" the corners or far sides of the patient's mouth, uncomfortably stretching the lips in a side-to-side dimension. Bumpers **138** aid in reducing or eliminating any such tendency, greatly increasing the comfort of the device as compared to available alternatives. In addition, as seen in FIG. **5**, there are no structures at the sides of the opening of the mouth that wrap around or grab the lips, forcing them far open side-to-side, as do many other devices. Rather, the only engagement with the outside of the lip occurs at the top and bottom of the mouth, with lip protecting members **130**, **132**. In addition, many retractors include a large continuous round or oval ring that extends about the lips on the anterior portion of the mouth to stretch the lips open. Such a ring pulls the lips side-to-side, causing them to be stretched open side-to-side to an uncomfortable degree. The sides of such a ring do not rest within upper or lower vestibules, but pass therebetween. No such anterior ring is necessary or required with the present frame. Rather, the upper and lower frame portions may reside entirely within the upper and lower vestibules.

[**0070**] FIGS. **6** through **11** illustrate another exemplary cheek and lip expansion device **200**, similar to device **100**. Device **200** similarly includes a flexible and resilient (e.g., spring-like) frame **202** that is selectively collapsible and expandable. Frame **202** may include an upper frame portion **204**, which may extend about the upper dental arch and bear against and retract cheeks and/or lips from teeth of the upper dental arch, and a lower frame portion **206**, which extends about the lower dental arch and retracts cheeks and/or lips from the jaw and teeth of the lower dental arch. Upper frame portion **204** may include first or left side member **208a** and right or second side member **208b**. Similarly, lower frame portion **206** may include left or first side member **210a** and right or second side member **210b**. First side members **208a**, **210a** may be joined to one another at their posterior ends to form a first posterior frame end or joint **216a**, and second side members **208a**, **210b** may be joined to one another at their posterior ends to form a second posterior frame end or joint **216b** on an opposite side of frame **202**. While described for simplicity as including various distinct portions or members, it will be appreciated that in some embodiments, any number of such sections or parts of the frame **202**, or the entire frame **202**, may be a one-piece, monolithic, or unitary structure, e.g., that may be integrally formed from a single piece of material (e.g., injection molded as such). Thus, where various ends or joints are described, it will be appreciated that such members or portions need not actually be separate, and then joined together (although such is certainly also possible)

[**0071**] An upper anterior connecting member **212** may be disposed between the anterior regions of upper side members **208a**, **208b**. A lower anterior connecting member **214** may be disposed between the anterior regions of lower side

members **210a**, **210b**. Upper anterior connecting member **212** may include first upper connecting portion **212a** adjacent to first upper side member **208a** and a second upper connecting portion **212b** adjacent to second upper side member **208b**, while lower anterior connecting member **214** may include first lower connecting portion **212a** adjacent to first upper side member **208a** and a second lower connecting portion **212b** adjacent to second upper side member **208b**. Upper anterior connecting member **212** is shown as being upwardly extended adjacent the central portion of upper frame portion **204** (e.g., corresponding to upper lip protecting member **230**), rather than simply running generally horizontally across the anterior side (as line  $L_c$  does). Such upward extensions **213** create an additional recessed space **205a** adjacent the upper anterior connecting member **212** and upper lip protecting member **230**. This space advantageously keeps the upper anterior connecting member **212** from uncomfortably contacting bone in this region of the anterior upper vestibule. The lower anterior connecting member **214** is shown as extending generally horizontally across this analogous space, as the upper and lower vestibule anatomy is different. Of course, if desired, a similar outward recessed extension could be provided here, removing the cross-member portion of **214** that spans the connection points of lower lip protecting member **232** such that first and second portions **214a** and **214b** of the lower anterior connecting member **214** connect only to the connection points of the lower lip protecting member **232**, thereby providing an additional flex or relief point. In other words, first and second portions **214a** and **214b** may not run generally horizontally, continuously between the anterior regions of lower side members **210a** and **210b**, but may include a forward extension and recess analogous to recess **205a** in the upper frame portion.

[0072] As with device **100**, a posterior width **220** of upper **204** and lower **206** frame portions as defined between posterior regions **216** may be greater than upper anterior width **222** and/or lower anterior width **222'** of the upper **204** and lower **206** frame portions, respectively. Such relationships may be as described previously in the context of device **100**, where posterior width **220** is greater than upper anterior width **222**, and upper anterior width **222** is greater than lower anterior width **222'**. Also similar to device **100**, frame **202** may also include a posterior crossbar **224** extending between posterior regions **216a** and **216b**. Because of the greater posterior width, the side members **208a**, **210a**, and **208b**, **210b** from posterior ends **216**, anteriorly forward, may be angled inwardly, towards the centrally disposed lip protecting members.

[0073] Illustrated upper and lower lip protecting members **230** and **232** are also somewhat different than those illustrated with device **100**. Both members **230**, **232** may include a hollow portion **230a**, **232a**, respectively. Upper lip protecting member **230** may include a cross-member **231** adjacent portion **230a**, which cross-member **231** may serve to latch with a corresponding latch member **233** of lower lip protecting member **232**. In addition, the upper lip protecting member **230**, particularly as it is extended upward due to extensions **213**, may act as a flex or relief point at which the various portions of the upper frame (e.g., upper anterior connecting member portions **212a**, **212b**, lip protecting member **230**, etc.) may begin to arc or bend to provide increased compliance and resiliency. As with device **100**, lip protecting members **230** and **232** may curve over and protect

the patient's lips during a dental procedure, extending outside the patient's mouth. Because of their extension outside of the mouth, they provide a convenient handle that can be gripped when removing or positioning the device. FIGS. **8** and **13C-14B** show the lip protecting members **230** and **232** selectively engaged with one another, with cross-member **231** latched with latch member **233**. For example, cross-member **231** may snap or compression fit under latch member **233**, holding cross-member **231**, and thus upper frame portion **204** latched to lower frame portion **206**. Tongue guard **234** is not shown in FIG. **8** so as to more clearly show the other structures. As seen in FIG. **8**, the side view of the expanded expansion device may be generally L-shaped, as defined by the upper and lower frame portions.

[0074] Instead of floating gussets **128**, posterior crossbar **224** of device **200** may be connected directly to the posterior ends of side members **208** and **210**, e.g., at the location of joints or posterior arced regions **216**. Posterior crossbar **224** may include a curved, bowed, v-shaped or u-shaped anteriorly curved portion **226** (e.g., centrally located along crossbar **224**) to facilitate side-to-side collapsibility of device **200**. As shown, a cross-member portion **227** of crossbar **224** may extend between the ends of v-shaped or u-shaped portion **226** (e.g., providing a triangular shaped portion in crossbar **224**). The anteriorly curved portion **226** and the cross-member portion **227** may also aid in removably attaching a tongue guard **234**, as shown. In some embodiments, the crossbar **224** may include first and second posteriorly curved portions **224a**, **224b**, which may be provided on either side of curved portion **226**, if present, e.g., with first curved portion **224a** between posterior end **216a** and centrally disposed curved portion **226**, and second curved portion **224b** between posterior end **216b** and centrally disposed curved portion **226**.

[0075] Tongue guard **234** is shown as differently configured than tongue guard **134** of device **100**. Tongue guard **234**, may be selectively removable (e.g., via a snap-fit compression-fit, or similar, as shown (e.g., FIG. **11** shows the tongue guard **234** detached). For example, a top surface of tongue guard **234** may include a recess **236** corresponding to curved portion **226**, allowing curved portion **226** to snap into recess **236**, attaching tongue guard **234** to posterior crossbar **224**, within centrally disposed anteriorly curved portion **226**. The expansion device **300** seen in FIG. **12A** is similar to expansion device **200**, but without the cross member portion **227** that extends fully across the rear of anteriorly curved central portion **226**. Rather, expansion device **300** includes a retention feature such as retention protrusions **227'**, which allows tongue guard **234** to be pressed into place from the rear of curved portion **226**, and retention protrusions **227'** flex to allow receipt of the tongue guard therein, and then spring back, retaining the tongue guard in place. Without such protrusions, the tongue guard may be more likely to fall out. For example, retention protrusions **227'** may extend inwardly from opposite sides of first and second curved members **224a**, **224b**, or from oppositely inwardly oriented sides of anteriorly curved portion **226**. Tongue guard **234** may be configured as a sheath, which may be closed at the anterior end, closed along the top, and open at the posterior end, so that the tongue may be introduced therein. The bottom end may also be largely open (see FIGS. **9** and **18C**). As such, structure **234** may serve as a garage into which the tongue may be introduced, so as to ensure the tongue does not interfere with practitioner

access to the desired areas of the oral cavity, while also protecting the top distal end of the tongue as it is enveloped by guard **234**.

**[0076]** When the patient's tongue is received within guard **234**, the naturally applied force may push the expansion device **200** forward (e.g., 1-4 mm), causing a further expansion of expansion device **200** within the oral cavity, to create an even greater clearance around the dental arches (i.e., between the dental arches and the cheeks and/or lips, as well as between the tongue (tongue guard **234**) and the lingual dental arch surfaces). Such forwardly applied force may work in conjunction with posterior loading of the device, e.g., as provided by loading of the crossbar **224** against the soft tissue covering the mandibular ramus and/or by loading of the posterior ends **216** on the backwall of the vestibule. Such abutment and loading of the frame relative to the mandibular ramus and posterior tissue of the oral cavity may result in increased three-dimensional inflation of the cheeks and lips in x-axis (side-to-side), y-axis (top-to-bottom), and particularly z-axis (forward) dimensions.

**[0077]** Clearance provided between the dental arch and the soft tissue of the cheeks and/or lips with the device in place may depend on the particular anatomy of a given patient, but may typically be as much as 2 cm, e.g., at least about 4 mm, at least about 8 mm, at least about 12 mm, etc. FIG. **10A** shows a typical clearance (C) in the lower vestibule, around the entire buccal side of the lower dental arch of 4 mm to about 2 cm, also showing good clearance on the lingual side of the lower dental arch, between the tongue guard **234** and the dental arch. As seen, the device is able to retract both the lips and the cheeks away from the dental arch, providing excellent clearance all around. All of this is advantageously accomplished without expanding the lips side-to-side to an extent that would be uncomfortable to the patient, as is often provided by other existing cheek or lip retractor devices. Rather, much of the retraction or expansion is achieved by pushing the lips forward, and the cheeks outwardly, rather than simply opening the mouth, and stretching the lips side-to-side as far as possible as in many prior retraction devices. Because of this difference, it is possible for the practitioner to asymmetrically pull one cheek or the other to one side or the other, for a wider working field on a given side, as shown in FIGS. **17A-17B**. While shown with use of a tongue guard, of course, any of the devices according to the present invention may be employed with or without a tongue guard.

**[0078]** FIGS. **10B** and **10C** show the side profile of the patient, both before (FIG. **10B**) and after (FIG. **10C**) installation and expansion of the device. FIG. **10C** shows how the upper and lower lips of the patient are flared and inflated forward, in the z-axis direction upon expansion of device **200**. The clearance C thus provided in the z-axis direction, between the upper lip and the upper dental arch is provided as the upper anterior connecting member **212** resides within the upper anterior vestibule, and the frame **202** is posteriorly loaded. For example, the posterior arced regions **216** may abut against the backwall of the facial vestibules, and portions **224a** and **224b** of posterior crossbar **224** may abut against the soft tissue over the ramus, pushing the expansion device **200** forward, so that upper anterior connecting member inflates, displaces, and flares the upper lip further away from the upper dental arch than would otherwise be the case. Similarly, the lower anterior connecting member **214** resides within the lower anterior vestibule, and the same posterior

loading described above similarly results in inflation and flaring of the lower lip forward, in the z-axis direction, away from the lower dental arch. Because of the anatomical differences described above in reference to the length of the upper side members **208** relative to the lower side members **210** (i.e., longer upper side members), in at least some embodiments, the upper lip may be flared out further than the flaring ( $\Delta z$ ) provided to the lower lip. Of course, the lower lip may also be flared out further, depending on the specific geometry of the expansion device. As seen in FIG. **10C**, as the expansion device **200** may also default the patient's jaw to an open position (due to the resilient top to bottom opening or loading force provided between the upper and lower frame portions **204**, **206** in the expanded configuration), the upper and lower lips may also be directed upwards and downwards, respectively, (in the y-dimension).

**[0079]** As will be apparent from FIGS. **10A-10C**, when installed, the expansion device pushes out on the lips and the cheeks simultaneously, retracting these soft tissues away from the dental arches. In that configuration, particularly when employed with a tongue guard such as guard **234**, the device "floats" within the mouth, acting as a tent or umbrella frame to expand the lips and cheeks (which are the "web"). The posterior crossbar **224** and/or posterior ends **216** may engage soft tissue covering the mandibular ramus, further pushing the device forward, as it "floats" within the mouth. Because of its "floating" and posteriorly loaded configuration, the posterior loading (which may be enhanced by the person pressing the tongue forward in guard **234**) can shift the device as a whole forward (e.g., 1-4 mm) in the z-axis direction, creating significantly more useful retraction of the cheeks and lips, as compared to existing devices, which are not configured to provide such posterior loading, and forward, z-axis inflation and flaring.

**[0080]** The described expansion devices also provide improved retraction or expansion adjacent the posterior regions of the dental arch, providing excellent clearance all around the dental arch, including the rear molars (e.g., the 2<sup>nd</sup> molars) or other posterior teeth, without the device blocking or impeding practitioner access to these areas around the posterior teeth. In addition, there is no need for an anterior continuous ring that circles the opening of the mouth, which can interfere with access to the cuspids and bicuspid. For example, such a ring present in the anterior portions of the oral cavity, between the cheeks or lips and the teeth, necessarily cross from the upper to lower vestibules or other portions of the mouth. Because such crossing occurs in the anterior region of the mouth (e.g., near the cuspids and/or bicuspid), it places frame structure where it interferes with the ability to access these tooth positions. The upper and lower frame portions of the present expansion devices rather run anteriorly-posteriorly, within the vestibule, and thus can avoid crossing from upper to lower regions of the mouth (and thus crossing over some tooth positions). Rather, no such upper to lower crossing occurs in the vicinity of the dental arches, but occurs only behind the dental arches, at posterior ends **216**.

**[0081]** Returning to FIG. **6**, one or more bumper covers **238'** may be provided over enlarged, thickened corner bumpers on frame **202**. While the anterior thickened corner bumpers on frame **202** are covered so as to not be visible in FIGS. **6-11**, they may be similar or identical to anterior corner bumpers **138** seen in FIGS. **1-5**, or those (**238**) of FIGS. **12A-16A**. Such underlying thickened corner bumpers



provide increased surface area for overmolding or otherwise bonding of softer, bumper covers **238'** thereover. In an embodiment, such bumper covers **238'** may comprise a different material than adjacent frame **202**, e.g., comprising a softer, flexible, and/or elastomeric material overmolded with respect to frame **202**. For example, bumper covers **238'** may have a Shore A durometer in a range from 0 to about 50, from 0 to about 25, or about 15. Tongue guard **234** may similarly be formed of a different material than frame **202**, and may have durometer characteristics that are harder than bumper covers **238'**. For example, tongue guard **234** may have a Shore A durometer hardness in a range from about 50 to about 100, from about 50 to about 90, or from about 60 to about 80. The tongue guard may comprise a material having greater flexibility and/or elasticity than the flexible spring-like frame.

**[0082]** Any device according to the present invention may advantageously allow full closure of the patient's mouth, with the device installed, as seen in FIGS. **17A-17B**. This is a distinct advantage over many existing cheek or lip retractor devices, where full closure of the jaw is not possible. Because closure of the jaw is possible, a practitioner may perform a bite-check without having to remove the device. As illustrated in FIGS. **10A-10C**, the devices **100** and **200** provide excellent displacement, retraction or expansion of both the lips and the cheeks, so as to provide a large clearance area (C) around the teeth where the practitioner would like to access, yet without stretching the lips in a side-to-side dimension to their limit. Such clearance provides excellent results for introduction of a dental drill, or for use with an intra-oral scanner, for example, to scan the dental and/or oral structures within the mouth (e.g., for digital crown manufacture). Another advantageous use of the expansion device may be for in-office tooth bleaching. Because the device provides such excellent clearance around the dental arches (i.e., between the dental arch and adjacent soft tissue cheeks and lips), there is less risk of contact between irritative tooth bleaching compositions and such soft tissues, which may otherwise irritate or burn the soft tissues.

**[0083]** In addition to allowing full closure of the jaw, the expansion devices according to the present invention may be configured so as to not block or impede practitioner access to the posterior teeth of a patient. For example, this may typically include bicuspids in children, or first and second molars (or even third molars) in adults. This is advantageous, as some retraction devices do not provide good access to the posterior teeth, particularly the rear molars. For example, the side members (e.g., **208** and **210**) and posterior crossbar (**224**) may tend to extend buccally, and generally parallel to, and then wrap around the dental arch, behind the rear molars. The crossbar **224** may reside in a retromolar region, e.g., between the ramus and the molars. In addition, as described above, the inclusion of thickened corner bumpers (e.g., **138**, **238**) within the anterior corners of the frame allows these thickened portions to reside within the anterior corners of the patient's vestibule, aiding in flaring the lips forward, and reducing any tendency of the device to uncomfortably "grab" or "jab" the corners of the mouth of the patient.

**[0084]** According to an embodiment, the frame of any of the embodiments may typically be formed from a polymeric material. For example, the frame may be injection molded or otherwise formed a thermoplastic or other suitable polymer

material (e.g., all as a single piece of material). In another embodiment, the frame may be formed of a shape-memory nickel-titanium alloy exhibiting a martensitic transformation temperature between ambient temperature (e.g., about 20° C.) and body temperature (e.g., 37° C.). Such a shape memory alloy could allow the expansion device to be highly deformable at ambient temperature prior to and during insertion, while become rigid as it warms to body temperature. This would be advantageous in practice because the alloy could be flexible and easily deformed before insertion, while still providing excellent retraction after warming up to body temperature. Inexpensively manufactured polymeric expansion devices may be intended for single use, so as to be disposed of after a single use. Plastic materials exhibiting sufficient flexibility for the frame have been found to provide excellent results. The flexibility may result from the geometry, e.g., the thinness of at least some portions of the various elongate members. For example, side members **208** and **210** include thinner central portions between their thickened posterior ends **240** and their thickened anterior ends **238**, allowing the members to flex and bend as needed for collapsibility. The posterior crossbar **224** is similarly flexible due to its geometry, including the thinness of the crossbar, and the variously curved portions (e.g., **224a**, **224b**, and **226**). In any case, the frame and its material is sufficiently flexible so as to allow flexing of the upper and lower frame portions towards one another, as well as flexing of the left and right sides towards one another. When released, the frame is able to recoil back to an expanded configuration. Some models, such as one formed of a shape memory nickel-titanium alloy, may be autoclaved or otherwise sanitized following use, so as to allow reuse of the device.

**[0085]** A device in which the frame is formed of a shape memory nickel-titanium alloy may further include an exterior coating (e.g., silicone, any suitable overmolded plastic, or other coating otherwise encapsulating the Ni—Ti frame) to retard (e.g., insulate) the temperature induced phase transformation of the nickel-titanium alloy. Such a coating may control the rate of heating of the frame after insertion, allowing retraction or expansion to occur at a gradual, comfortable and gentle pace.

**[0086]** FIGS. **12A-12C** show further exemplary cheek and lip expansion devices according to the present invention. FIG. **12A** shows a device **300** similar to device **200**, but without the bumper covers **238'**, and without a continuous cross-member **227** spanning central anteriorly curved portion **226**. Device **300** includes a flexible spring-like frame **202**, including an upper frame portion **204** and a lower frame portion **206** which are flexible and resilient so as to selectively assume collapsed and expanded configurations during installation and use. As with device **200**, both upper and lower frame portions **204** and **206** include upper side members **208** and lower side members **210**. Upper anterior connecting member **212** joins together the anterior portions or ends of the first and second upper side members **208a** and **208b**. Lower anterior connecting member **214** joins together and extends between the anterior portions or ends of the first and second lower side members **210a** and **210b**. The posterior regions of the first upper and lower side members **208a**, **210a** are joined at posterior arced region **216a**, while the posterior regions of the second upper and lower side members **208b**, **210b** are joined at posterior arced region **216b**. Posterior regions **216** form flexible yet sufficiently rigid joints that resist bending at a single point, but rather

distribute the bending moment along a substantial length of the upper and lower side members **208**, **210** during collapse along the y-axis. Distribution of the bending or flexing forces associated with top to bottom collapse of the expansion device is aided by providing the posterior ends of side members **208** and **210**, where they join (at posterior regions **216**) with a thickened structure **240**, so that the thickened cross-section at the posterior regions **216a**, **216b** resist bending, forcing the bending to occur more anteriorly along the upper and lower frame portions (where the side members are thinner). As a result, when bending, little to no actual bending or flexing may occur within the region of posterior arced regions **216a**, **216b**, as seen in FIGS. **13A-13C**. Such a configuration prevents posterior arced regions (also referred to herein as joints) **216a**, **216b** from becoming increasingly acute, and jabbing into the backwall of the vestibule during insertion or use, providing greatly increased comfort.

[**0087**] As seen in FIG. **12A** (also particularly apparent in FIGS. **1-5**), the upper and lower frame portions of the device may include distinct anterior corners, which are defined by a relatively tight radius of curvature across bumpers **138**, **238**, at the corners. For example, the radius of curvature across bumpers **138** or **238** may be in a range of about 8 to about 22 mm, about 10 to about 20 mm, or about 15 mm. The upper and lower frame portions are not simply rounded, e.g., with an oval or circular configuration, or defined by a generally constant radius of curvature over a significant portion of their length. As shown in FIG. **12A** and FIGS. **1-5**, the side members on either side of the upper and lower frame portions may be relatively straight from the thickened posterior regions **216** towards the forward (anterior) direction, towards the relatively tightly curved corners at anterior bumpers **138** or **238**. Such tightly curved corners **138**, **238** (e.g., they could be termed “squared corners”) conform to the anatomical shape of the upper and lower anterior vestibules between the dental arch, gums and the person’s lips. The upper anterior corner bumpers **138**, **238** may also angle or flare downwardly and outwardly across the thickened section, while the lower anterior corner bumpers **138**, **238** may similarly angle or flare upwardly and outwardly. This is perhaps best seen in the corner bumpers of FIGS. **2** and **13C**. Such configurations ensure that the frame does not contact or irritate the canine prominence of a patient. Such shape and contouring provides increased comfort to the patient.

[**0088**] Because of anatomical differences in the length of the upper and lower dental arches and associated vestibules, the two upper corner thickened bumpers **138**, **238** of the upper frame portion may be further apart from one another as compared to the two lower corner bumpers **138**, **238** of the lower frame portion. As described relative to the anterior width of the upper and lower frame portions, the upper frame anterior width **122** may be greater than the lower frame anterior width **122'** (see FIGS. **1**, **2**, and **6**). Where the corner thickened bumpers **138**, **238** are positioned at the ends of the anterior width (i.e., the intersection between the side members and the corresponding upper or lower anterior connecting members), the distance between such corner thickened bumpers also differs from upper to lower, with the upper corner thickened bumpers **138**, **238** being further apart from one another than the lower corner thickened bumpers **138**, **238**. Such a difference anatomically conforms to differences in sizes of the upper and lower dental arches, and the upper and lower anterior vestibules. This difference may

also cause the upper lip to flare out further (in the forward, z-direction) than flaring of the lower lip. For example, the upper lip may actually be forward of the lower lip, or the  $\Delta z$  difference provided by the expanded device may exhibit a greater  $\Delta z$  in the upper lip than the lower lip (i.e., difference in positions of the upper lip due to the expanded device may be greater than the difference in lip positions of the lower lip, due to the expanded device).

[**0089**] Also for anatomical reasons, the upper corner thickened bumpers **138**, **238** may be more rounded, and enlarged as compared to the two lower corner thickened bumpers **138**, **238**. Larger, upper corner bumpers also aids in ensuring that the upper lip is flared out further than the lower lip. As described herein, one or both of the upper or lower corner thickened bumpers **138**, **238** may include a bumper cover (e.g., **238'** of FIGS. **6-9** and **11**) comprising a material with greater softness, greater flexibility, and/or greater elasticity than the underlying bumpers of the frame. Such cushioning bumper covers **238'** may provide a comfortable elastic cushion between the upper and lower gums and lips. FIGS. **12A-16A** do not show any bumper covers, in order to better show the underlying frame geometry, particularly bumpers **238** that such covers may be bonded to or otherwise attached to.

[**0090**] Device **300** is further shown as including a posterior crossbar **224** interconnecting the posterior arced regions **216** of the first and second upper and lower side members **208** and **210**. As described, crossbar **224** may be configured, in combination with a mandibular ramus, to effect posterior loading of the flexible, resilient frame **202**, which posterior loading assists in flaring the cheeks and lips outward, forward, and open (i.e., in x, y, and z-axis directions).

[**0091**] As shown in FIG. **12A** and described previously, the posterior crossbar **224** may include first and second curved members **224a** and **224b** which are posteriorly curved (i.e., curved backwards), so as to represent the most posteriorly disposed portions of the expansion device (e.g., see the side views of FIGS. **3** and **8**). The posteriorly curved members **224a**, **224b** may be joined at essentially a middle portion of the crossbar **224**, near anteriorly curved portion **226**. Crossbar **224** may thus include three curves (e.g., two posteriorly curved portions **224a** and **224b**, and an anteriorly curved portion **226** or other middle flexure feature). Because of the posterior curvature of members **224a**, **224b**, these posteriorly curved portions can load against the soft tissue covering mandibular ramus of the patient, so that the ramus applies posterior loading to the device through crossbar **224**, pushing the device **300** forward. Such posterior loading further flares the lips of the patient forward, increasing the working field available within the mouth, particularly adjacent the lips. Curved members **224a**, **224b** may also facilitate the collapsed insertion configuration of the frame, where the frame is collapsible from side-to-side upon application of a side-to-side collapsing force, as well as facilitating the expanded configuration of the frame, where the frame is outwardly expanded by opening up from side-to-side as the collapsing force is released. Posteriorly curved members **224a**, **224b** may also aid in preventing stimulation of the gag reflex of the patient.

[**0092**] Rather than continuous cross-member **227** across the rear of anteriorly curved portion **226**, the configuration of FIG. **12A** shows retention protrusions **227'**, which aid in retaining tongue guard **234** in place, while also allowing its insertion from behind. In addition, by removing the con-

tinuous cross-member 227 (and even with retention protrusions 227'), the ease of collapsing the frame from side-to-side is improved.

[0093] FIG. 12B illustrates another device 400 also similar to device 200, but without the crossbar 224. Even without such a crossbar, the posterior ends 216 have been found by the inventors to provide for at least some degree of posterior loading of the device as the posterior ends 216 bear against the backwall of the vestibule of the patient. FIG. 12C illustrates another device 500 similar to devices 200, 300, and 400, but in which most of the posterior crossbar 224 has been removed. Device 500 instead provides inwardly protruding extensions 546 on posterior arced regions or joints 216a, 216b. Such elongate extensions may be sufficient in length (e.g., 0.25 inch to 1 inch in length) to still provide posterior loading of extensions 542 on the mandibular ramus of the patient, without providing a continuous crossbar between posterior arced regions 216. Where such extensions are provided, they may be rounded at their free ends for comfort. It will be apparent than in devices 400 and 500, no tongue guard may be provided.

[0094] In an embodiment, the posterior crossbar 224 may be selectively removable from the remainder of frame 202. For example, the crossbar could be configured as a tube that fits over projections such as projections 542 seen in device 500, or a ball and socket joint could be provided at each end (e.g., at joints 216), or any other suitable connection mechanism (e.g., press-fit, friction fit, snap fit, etc.) could be provided. If desired, a practitioner could convert the configuration seen in FIG. 12A to that of 12B or 12C by simply cutting or otherwise removing some portion or all of the crossbar 224.

### III. Exemplary Methods of Placement and Use

[0095] FIGS. 13A-17B illustrate various aspects associated with placement and use of the cheek and lip expansion devices. For example, FIGS. 13A-13C show how the device 300 may be collapsed from top to bottom. FIG. 13A shows partial collapse as compared to the expanded state seen in FIG. 12A, while FIG. 13B shows progressively further top to bottom collapse, and FIG. 13C shows device 300 collapsed top to bottom to the degree that the latch member 233 can be engaged with cross-member 231. As shown, (e.g., see FIG. 13B), the cross-member 231 may include a recess formed into the posterior surface of the cross-member, into which latch member 233 is received, latching the upper and lower frame portions 204, 206 to one another.

[0096] A comparison of FIG. 12A with FIGS. 13A-13C show how the upper and lower side members (e.g., 208a and 210a on a first side and 208b and 210b on a second side) are joined at their posterior ends to form first and second bendable radii about arced regions 216, which resist bending at a distinct point so as to spread the bending forces out away from regions 216, towards the other portions of the side members 208 and 210. For example, because of the thickening 240 at posterior regions 216, little to no bending may actually occur at this posterior location, while the majority of the bending may occur along the thinnest regions of the side members (e.g., between thickened bumpers 238 and thickened posterior ends 240). Other mechanisms could alternatively be employed to similarly resist bending at a desired distinct location (e.g., use of a different material, etc.).

[0097] FIG. 13C also perhaps best illustrates how the thickened corner anterior bumpers 238 of both the upper and lower frame portions may also be anatomically angled, so as to more comfortably fit within the upper and lower corners of the anterior vestibule. Specifically, the lower bumper is shown as angling upward and outward, and the upper bumper as angling downward and outward. For example, as labeled on the left side in FIG. 13C, the lower corner bumper 238 may include outside and inside angled surfaces 348 and 350, respectively. Such angles match the anatomy of the corners of the vestibule into which lower bumper 238 is to be received. Similarly, the upper corner bumper 238 is shown as including outside and inside angled surfaces 352 and 354, respectively, which angles match the anatomy of the corners of the vestibule into which the upper bumper 238 is to be received. For example, the lower outside angle 348 may be in a range from about 40° to about 80°, or from about 50° to about 70° (e.g., about 60°) relative to horizontal (e.g., a horizontal line running across the bottom of lower connecting member 214). The lower inside angle 350 may be in a range from about 10° to about 50°, or in a range from about 20° to about 40° (e.g., about 30°) relative to horizontal (e.g., a horizontal line running across the bottom of lower connecting member 214). The upper outside angle 352 may be in a range from about 30° to about 70°, or in a range from about 40° to about 60° (e.g., about 50°) relative to horizontal (e.g., a horizontal line running across the bottom of lower connecting member 214). The upper inside angle 354 may be in a range from about 20° to about 60°, or in a range from about 30° to about 50° (e.g., about 40°) relative to horizontal (e.g., a horizontal line running across the bottom of lower connecting member 214). In an embodiment the lower and upper outside angles 348 and 352 may be approximately equal (and in opposite directions), being angled towards one another, as shown. In another embodiment, the angles may differ (e.g., upper greater than lower, or lower greater than upper). These angulated upper and lower thickened corner bumpers 238 extend outwardly, towards the bony structure bounding the vestibule. Similar anatomical angulation may be provided on the right side upper and lower bumpers 238.

[0098] In addition to this collapsibility in a top to bottom dimension, the device may also be configured as described above, to collapse side-to-side. FIGS. 14A and 14B illustrate how a practitioner may collapse the device side-to-side, due to the flexible, spring-like characteristics of the frame 202. Where no crossbar is present (e.g., see FIG. 12B), the posterior ends 216 may be pressed towards one another, to collapse the device in a side-to-side dimension. Even where a crossbar 224 is present, as seen in FIG. 12A and FIGS. 14A-14B, the crossbar 224 may include an anteriorly curved central portion 226, which facilitates side-to-side collapse as the posterior ends of the device are pushed towards one another. The two posteriorly curved portions 224a and 224b may also facilitate side-to-side collapse. During collapse, the curved portion 226 advances forwardly, e.g., and may pass over or under lower anterior connecting member 214, depending on the degree of side-to-side collapse. Posteriorly curved members 224a and 224b may also move closer together, accommodating the collapse, as seen in FIGS. 14A and 14B. As seen in FIG. 14A, as posterior arced regions 216 are pressed towards one another, the ends of curved members 224a, 224b adjacent central curve 226 may become increasingly parallel to one another, and then possibly eventually touching, as seen in FIG. 14B, depending on the

degree of side-to-side collapse. Such a top to bottom and side-to-side collapsed configuration as seen in FIGS. 14A or 14B is particularly compact, making it quite easy to insert into a patient's mouth without requiring the patient to open their mouth to an uncomfortable degree.

[0099] FIGS. 15A-15B illustrate one exemplary method of insertion, while FIG. 16A illustrates another method. As shown in FIG. 15A, the practitioner may collapse the expansion device 300 top to bottom, while employing little if any of the side-to-side collapsibility of the expansion device. Rather, the practitioner may wish to insert one posterior arced region 216 of the expansion device 300 into one side of the mouth followed by shoehorning the other posterior arced region 216 into the mouth. Because the device is collapsed top to bottom during such insertion, the patient is not required to open their mouth to an uncomfortable degree, but may simply insert one posterior region (e.g., 216a) towards the rear of the vestibule or oral cavity, and then swing the other posterior region (e.g., 216b) into place, towards the opposite vestibule. If desired, while swinging the second posterior end into place, some of the device's side-to-side collapsibility may be employed, should the practitioner simply compress the two posterior ends 216 towards one another.

[0100] FIG. 16A illustrates another method of insertion, where no such shoehorning of one posterior side and then the other may be employed, but where the expansion device is collapsed top to bottom (e.g., and latched in that collapsed state), and then also collapsed side-to-side as seen in FIGS. 14A and 14B. By employing the latch, such may easily be achieved with a single hand. The width of the expansion device is so small when so collapsed, that it easily fits into the mouth of a patient, without requiring them to open their mouth to an uncomfortable degree. By way of example, the top to bottom collapse may reduce the height of the device from about 85-100 mm (expanded) to about 30 mm (e.g., a reduction of 50% or more, or 60% or more (e.g., about 50% to about 70%)). The side-to-side collapse may reduce the width of the device from about 100 mm (expanded) to about 60-70 mm (e.g., a reduction of about 30% to about 40%). As will be apparent the majority (perhaps nearly all) of the side-to-side collapse occurs posteriorly, making the posterior collapsed width similar to that of the anterior widths 122 and 122' described in conjunction with FIGS. 1 and 6. Such decreased height and width allows the multi-dimensionally collapsed expansion device to easily be inserted into the mouth of the patient, as seen in FIG. 16A. No uncomfortable opening of the mouth, or uncomfortable side-to-side stretching of the lips is needed.

[0101] In either case, once inserted and expanded, the expansion device "floats" within the patient's mouth, with the side members 208, 210 of the upper and lower frame portions 204 and 206 resting in the upper and lower vestibules of the patient, between the alveolar ridge and the lips or cheeks. The posterior crossbar 224 (if present) crosses from one side of the dental arches to the other, in a retromolar region, behind the molars of the patient. As described above, the crossbar 224 may bear against the soft tissue covering the mandibular ramus R of the patient, exerting a forward force on the device, pushing it forward. FIGS. 16B-18D show how the soft tissue covering the mandibular ramus R is abutted by the posteriorly curved portions of crossbar 224, providing the desired posterior loading. Such posterior loading further flares the upper lips

forward (in the z-dimension) and upward (in the y-dimension) and the cheeks outward (in the x-dimension). The lower lips are similarly further flared forward, (in the z-dimension), downward (in the y-dimension), with the cheeks being flared outward (in the x-dimension). Such posterior loading thus widens the working field. Only the lip protecting members of the expansion device may reside outside of the mouth (over the center of the upper and lower lips), with the other portions of the frame being received within the mouth. Side members 208 and 210 may be received within the upper and lower facial vestibules, and the upper and lower anterior connecting members may be received within the upper and lower anterior vestibules. No portion interferes with access to the dental arches. If a posterior crossbar is present, the crossbar 224 passes retro-molarly, between the posterior teeth and the ramus.

[0102] FIGS. 16B and 16C illustrate how when positioned within the person's mouth, the patient still has full movement of their jaw, so as to allow the user to open and close their jaw as normally possible. FIG. 16B shows the jaw open, with FIG. 16C showing the jaw closed. No portion of the frame interferes with this ability to fully open and fully close the jaw, while the expansion device is in the mouth. As seen in FIG. 16C, the expansion device holds the lips comfortably retracted or expanded from the dental arches, so that the teeth of both arches are easily and fully visible, even with the jaw closed. As seen, the frame inflates, displaces, and flares the patient's cheeks and lips away from the teeth, so that no contact is made between the frame and the teeth or gums. The frame may be devoid of any structures that would obstruct access to the teeth when the frame is expanded, and that would prevent the patient from fully biting down and making full occlusal contact between the person's upper and lower teeth. For example, the frame may be devoid of any structures interconnecting the upper and lower frame portions apart from the posterior crossbar, so as to not impede access to the person's teeth and gums when the frame is expanded in the mouth. The posterior crossbar 224 does not impede access, as it passes across the retromolar region, so as to not interfere with the 2<sup>nd</sup> or even the 3<sup>rd</sup> molars, if present. In addition, no anterior ring is present that circles the perimeter of the patient's mouth opening, which uncomfortably stretches the lips side-to-side, and which can interfere with access to certain teeth (e.g., canines and bicuspids, as it passes from the upper to lower portions of the oral cavity).

[0103] The frame may be flexible when expanded in the mouth so as to permit all typical functional movements of the person's mandible in x-axis (side-to-side), y-axis (up and down), and z-axis directions (forward and backward). In other words, the person is able to close the mandible (generally a y-axis movement), as well as move the mandible in any other typical motion possible when the frame is not expanded within the mouth. The frame simply floats within the vestibule portion of the mouth, between the cheeks/lips and the dental arch (teeth and gums in the alveolar ridge), inflating the cheeks and lips outwardly and forwardly, but permits normal movement and functioning of the jaw when expanded within the mouth. Of course, the cheeks and lips are held outward and forward, inflated away from their normal positions when a mouth is closed with no such device inserted.

[0104] In an embodiment, the frame does not fully stretch the lips side-to-side around the person's mouth, to their

limits, but rather holds them open, and flares them forward, to a comfortable degree, all while providing a widened working field for the practitioner. In other words, the frame inflates and flares the lips forwardly and away from the anterior teeth in a z-axis direction without fully stretching the lips side-to-side in an x-axis direction. This permits the persons lips and cheeks to be asymmetrically deformed, facilitating enlargement of the working field on a particular side of the mouth. For example, many existing retraction devices grab the lips on opposite sides of the mouth, pulling them apart side-to-side. As seen in FIGS. 17A and 17B, the present devices do not so stretch the lips, but allow further expansion of one side or the other. In other words, Because of the comfortable expansion of the lips and cheeks that is instead provided, the practitioner can reach into the mouth and pull the lips to one side or the other, expanding one side or the other side asymmetrically, as seen in FIGS. 17A-17B. This permits asymmetric deformation of the lips to either side, facilitating further enlargement of the working field on a particular side of the mouth. In addition, while so doing, as the expansion device itself “floats” within the mouth, such movements or expansions by the practitioner generally does not move the device, which remains generally in the same position in the mouth.

[0105] As will be apparent from the described methods and from FIGS. 13A-17B, the flexible spring-like frame provides an insertion configuration wherein the frame is inwardly collapsible in multiple dimensions, e.g., at least from top to bottom, and from side-to-side. During such collapse in two dimensions, some collapse in the third dimension (z-axis—forward to back) may also occur. The flexible spring-like frame also provides a second, expanded configuration, where the frame is outwardly expandable by opening up from top to bottom and from side-to-side. The expanded configuration provides retraction of a person’s cheeks and lips to create an enlarged working field that permits unobstructed access to both upper and lower dental arches, including all teeth from the second molar position forward. The upper frame portion 204 of the frame is configured to extend continuously about the upper dental arch, from a first posterior arced region (e.g., 216a) that is behind a second molar position on one side of the upper dental arch to a second posterior arced region (e.g., 216b) that is behind a second molar position on an opposite side of the upper dental arch. The lower frame portion 206 is configured to continuously extend about the lower dental arch, from the first posterior arced region (e.g., 216a) that is also behind the second molar position on one side of the lower dental arch to the second posterior arced region (e.g., 216b) that is also behind the second molar on the opposite side of the lower dental arch. The first and second posterior regions 216 join the upper and lower frame portions 204, 206 to one another, and provide a bendable radius on either side (e.g., about arced region 216a, along side members 208a, 210a, and about end 216b, along side members 208b, 210b) that facilitates the insertion configuration, where the frame is inwardly collapsible from top to bottom, as well as the expanded configuration, where the frame is outwardly expanded by opening from top to bottom. The posterior arced regions 216 may also be collapsed side-to-side, towards one another, facilitating side-to-side collapse of the frame, and its subsequent expansion upon release of the collapsing force. The posterior regions 216 may be thickened in the vicinity of the frame where such ends are located,

so as to better resist bending at that particular point, distributing the bending forces along a greater length on either side of the arced region, into the side members. Such thickened regions 240 also help to open the frame upward, (i.e., top to bottom), creating increased resistance to closing of the jaw-like frame. The frame components, particularly the side members 208, 210, thus include relatively thinner cross-sections through essentially the middle portion of each side member of the upper and lower frame portions, causing much of the bending to occur within these thinner frame structures.

[0106] The shape of the side members 208, 210, upper and lower anterior connecting members 212, 214, and the frame 202 in general, may be configured to follow the contours of the portions of the vestibule into which any given particular portion is to be received. For example, the side members 208, 210 of the upper and lower frame portions may be curved and shaped anatomically, for receipt into the facial vestibule on either side of the dental arches. Similarly, the anterior corner bumpers 238 at the anterior ends of each side member may be shaped, curved, and sized for receipt into the corners of the anterior portions of the upper and lower vestibules, at the front of the dental arches. Because of differences in the upper and lower dental arches, and in the upper and lower vestibules associated with such arches, the upper and lower frame portions may be differently sized and shaped. For example, the lower frame 206 may be overall shorter, and narrower at its anterior front width, while the upper frame portion 208 is overall longer, and wider at its anterior front width. The side members 208 of the upper frame portion may be shorter than the side members 210 of the lower frame portion, and the thickened anterior corner bumpers 238 of the upper frame may be more rounded, and larger than those of the lower frame portion. All such differences better accommodate the actual anatomy of the person, providing better comfort when the frame is expanded within the vestibules.

[0107] The upper and lower frame portions (particular the side members of each) expand the upper and lower facial vestibules (e.g., adjacent the cheeks) laterally (side-to-side—in the x direction), flaring the cheeks outwardly as the frame resides within the vestibule, expanding and flaring the cheeks outward, like a tent. The upper and lower anterior vestibules are similarly expanded, but in a forward direction (in the z-direction), flaring the lips forward. The upper and lower anterior vestibules are also expanded in the y-direction, retracting the upper lips upwardly and the lower lips downwardly. In other words, the cheeks are expanded in the x-direction, while the lips are generally expanded in the z and y directions.

[0108] FIGS. 18A-18D illustrate how the tongue guard 234 may gently house the tongue, so as to reduce its interference with the practitioner’s working field, protecting the tongue from injury, but at the same time allowing the patient to move the tongue up, down, or to either side. The tongue guard may hold and guide the person’s tongue, but may not significantly push the tongue back, flatten the tongue, or thicken the tongue. Flattening or thickening the tongue (by pushing it down or back) may increase risk of injury, as it increases the surface area of the tongue as a target for a drill or other dental tool. Many other existing tongue guard devices tend to forcefully push the tongue back, flatten the tongue, or thicken the tongue, which can be uncomfortable to the patient, while also increasing injury

risk. The tongue guard may hold the tongue in place, even if the jaw is closed, a characteristic which also differs from many existing retraction devices. For example, FIGS. 18A-18D shows how the patient may move the distal tip of the tongue within tongue guard 234 to the right (FIG. 18A), to the left (FIG. 18B), up (FIG. 18C) or down (FIG. 18D). Tongue guard 234 holds and guides the distal tip of the tongue, while still permitting such movement by the patient. The tongue is not significantly flattened or thickened, particularly the exposed portions thereof.

[0109] As used in this specification and the appended claims, the singular forms “a,” “an” and “the” include plural referents unless the context clearly dictates otherwise.

[0110] The present invention may be embodied in other specific forms without departing from its spirit or essential characteristics. The described embodiments are to be considered in all respects only as illustrative and not restrictive. The scope of the invention is, therefore, indicated by the appended claims rather than by the foregoing description. All changes which come within the meaning and range of equivalency of the claims are to be embraced within their scope.

What is claimed is:

1. A frame of a cheek and lip expansion device configured to extend about dental arches of a user, the frame comprising:

- a upper frame portion including a first upper side member, a second upper side member, and an upper anterior connecting member that joins the first upper side member and the second upper side member at anterior regions of the first upper side member and the second upper side member;
- a lower frame portion including first lower side member, a second lower side member, and an lower anterior connecting member that joins the first lower side member and the second lower side member at anterior regions of the first lower side member and the second lower side member;
- a first thickened structure positioned at a first posterior region of a frame, the first thickened structure being connected to the first lower side member and the first upper side member and having an enlarged cross-section relative to adjacent portions of the first lower side member and the first upper side member; and
- a second thickened structure positioned at a second posterior region of the frame that is substantially opposite the first posterior region, the second thickened structure being connected to the second lower side member and the second upper side member and having an enlarged cross-section relative to adjacent portions of the second lower side member and the second upper side member,

wherein:

- the frame is configurable in a collapsed arrangement in which the lower anterior connecting member is bent towards the upper anterior connecting member responsive to imposition of a flexing force;
- the first and the second thickened structures are resistant to bending; and
- in the collapsed arrangement, the flexing force is substantially transferred from the first and the second thickened structures to the adjacent portions of the first and second lower side members and the first and second upper side members.

2. The frame of claim 1, wherein:

- the first upper side member, the first lower side members, and the first thickened structure form a first bendable radius; and
- the second upper side member, the second lower side members, and the second thickened structure form a second bendable radius.

3. The frame of claim 1, further comprising a posterior crossbar that connects the first thickened structure to the second thickened structure.

4. The frame of claim 3, wherein:

- the posterior crossbar comprises a first and a second posteriorly curved members; and
- a middle portion of the posterior crossbar are anteriorly curved to facilitate inward collapse of the frame from side-to-side as the first thickened structure and the second thickened structure posterior are pressed towards one another.

5. The frame of claim 1, wherein the upper anterior connecting member includes a greater anterior width than an anterior width of the lower anterior connecting member.

6. The frame of claim 1, further comprising:

- two upper corner thickened bumpers positioned on the upper frame portion; and
- two lower corner thickened bumpers positioned on the lower frame portion, wherein the two upper corner bumpers are further apart from one another than the two lower corner bumpers.

7. The frame of claim 6, wherein:

- the upper corner thickened bumpers are rounded and enlarged as compared to adjacent portions of the upper frame portion; and
- the lower corner thickened bumpers are rounded and enlarged as compared to adjacent portions of the lower frame portion.

8. The frame of claim 6, wherein the upper and lower corner thickened bumpers are comprised of an elastomeric material disposed over the upper frame portion and lower frame portion, respectively.

9. A cheek and lip expansion device, the device comprising:

- a first thickened structure positioned at a first posterior region of a frame, the first thickened structure having an enlarged cross-section relative to adjacent frame portions;
- a second thickened structure positioned at a second posterior region of the frame that is substantially opposite the first posterior region, the second thickened structure having an enlarged cross-section relative to adjacent frame portions;
- an first frame portion that extends from the first thickened structure to the second thickened structure, the first frame portion being configured to extend about an upper dental arch of a user and including a first subset of the adjacent frame portions; and
- a second frame portion that extends from the first thickened structure to the second thickened structure, the second frame portion being configured to extend about a lower dental arch of the user and including a second subset of the adjacent frame portions,

wherein:

- the frame is configurable in a collapsed arrangement in which an anterior portion of the first frame portion is bent towards an anterior portion of the second frame portion responsive to imposition of a flexing force;

the frame is further configurable in an expanded arrangement responsive to removal of the flexing force;

the first and the second thickened structures are resistant to bending; and

in the collapsed arrangement, the flexing force is substantially transferred from the first and the second thickened structures to the adjacent frame portions such that the adjacent frame portions flex.

**10.** The device of claim **9**, wherein:

the first frame portion includes a first upper side member, a second upper side member, and an upper anterior connecting member that joins the first upper side member and the second upper side member at anterior regions of the first upper side member and the second upper side member;

the second frame portion includes first lower side member, a second lower side member, and a lower anterior connecting member that joins the first lower side member and the second lower side member at anterior regions of the first lower side member and the second lower side member;

the first thickened structure is connected to a posterior portion of the second lower side member and a posterior portion of the second upper side member; and

the second thickened structure is connected a posterior portion of the second lower side member and a posterior portion of the second upper side member.

**11.** The device of claim **10**, wherein the upper anterior connecting member includes a greater anterior width than an anterior width of the lower anterior connecting member.

**12.** The device of claim **10**, further comprising a posterior crossbar that connects the first thickened structure to the second thickened structure, wherein:

the posterior crossbar comprises a first and a second posteriorly curved members; and

a middle portion of the posterior crossbar are curved to facilitate inward collapse of the frame from side-to-side as the first thickened structure and the second thickened structure posterior are pressed towards one another.

**13.** The device of claim **12**, wherein the frame is devoid of any structures interconnecting the upper and lower frame portions apart from the posterior crossbar.

**14.** The device of claim **10**, further comprising:

two upper corner thickened bumpers positioned on the first frame portion; and

two lower corner thickened bumpers positioned on the lower frame portion,

wherein the upper and lower corner thickened bumpers are comprised of an elastomeric material disposed over the first frame portion and lower frame portion, respectively.

**15.** The device of claim **14**, wherein:

one of the two upper thickened bumpers is positioned between the first upper side member and the upper anterior connecting member;

another of the two upper thickened bumpers is positioned between the second upper side member and the upper anterior connecting member;

one of the two lower thickened bumpers is positioned between the first lower side member and the lower anterior connecting member; and

another of the two lower thickened bumpers is positioned between the second lower side member and the lower anterior connecting member.

**16.** The device of claim **14**, wherein the two upper corner bumpers are further apart from one another than the two lower corner bumpers.

**17.** The device of claim **14**, wherein:

the upper corner thickened bumpers are rounded and enlarged as compared to adjacent portions of the upper frame portion; and

the lower corner thickened bumpers are rounded and enlarged as compared to adjacent portions of the lower frame portion.

**18.** A frame of a cheek and lip expansion device, the frame comprising:

a first thickened structure positioned at a first posterior region of the frame, the first thickened structure having an enlarged cross-section relative to adjacent frame portions;

a second thickened structure positioned at a second posterior region of the frame that is substantially opposite the first posterior region, the second thickened structure having an enlarged cross-section relative to adjacent frame portions;

an first frame portion that extends from the first thickened structure to the second thickened structure, the first frame portion being configured to extend about an upper dental arch of a user and including a first subset of the adjacent frame portions; and

a second frame portion that extends from the first thickened structure to the second thickened structure, the second frame portion being configured to extend about a lower dental arch of the user and including a second subset of the adjacent frame portions,

wherein:

the first and the second thickened structures are resistant to bending; and

the first and the second thickened structures are configured to transfer a flexing force acting to press the first frame portion towards the second frame portion to the adjacent frame portions.

**19.** The frame of claim **18**, wherein:

the first frame portion and the second frame portion are configurable in a collapsed arrangement in which an anterior portion of the first frame portion is bent towards an anterior portion of the second frame portion responsive to imposition of the flexing force;

the first frame portion and the second frame portion are further configurable in an expanded arrangement responsive to removal of the flexing force; and

in the collapsed arrangement, the flexing force is substantially transferred from to the adjacent frame portions such that the adjacent frame portions flex.

**20.** The frame of claim **18**, further comprising a posterior crossbar that connects the first thickened structure to the second thickened structure, wherein:

the posterior crossbar is configured for inward collapse from side-to-side as the first thickened structure and the second thickened structure are pressed towards one another; and

the frame is devoid of any structures interconnecting the first and the second frame portions apart from the posterior crossbar.