



US 20240023635A1

(19) **United States**

(12) **Patent Application Publication**
HAWES et al.

(10) **Pub. No.: US 2024/0023635 A1**

(43) **Pub. Date: Jan. 25, 2024**

(54) **E-VAPING DEVICE INCLUDING E-VAPING CASE WITH SLIDING MECHANISM FOR INITIATING VAPOR GENERATION**

Publication Classification

(51) **Int. Cl.**
A24F 40/60 (2006.01)
A24F 40/40 (2006.01)
(52) **U.S. Cl.**
CPC *A24F 40/60* (2020.01); *A24F 40/40* (2020.01)

(71) Applicant: **Altria Client Services LLC**,
Richmond, VA (US)

(72) Inventors: **Eric HAWES**, Midlothian, VA (US);
Chris SIMPSON, Richmond, VA (US);
Terrance Theodore BACHE,
Richmond, VA (US); **David SCHIFF**,
Highland Park, NJ (US)

(73) Assignee: **Altria Client Services LLC**,
Richmond, VA (US)

(21) Appl. No.: **18/477,967**

(22) Filed: **Sep. 29, 2023**

Related U.S. Application Data

(63) Continuation of application No. 16/989,087, filed on Aug. 10, 2020, now Pat. No. 11,800,900, which is a continuation of application No. 15/390,811, filed on Dec. 27, 2016, now Pat. No. 10,765,148.

(57) **ABSTRACT**

An e-vaping case includes a housing, a guide structure, a cartridge receiving portion connected to the guide structure, and an electronics system in the housing. The cartridge receiving portion is configured to be moved along the guide structure between a first surface and a second surface of the housing. The electronics system includes a power supply that is configured to initiate a transfer of power to an electrical contact structure if the cartridge receiving portion is moved towards the first surface of the housing to at least a first position of the housing. The electronics system is configured to interrupt the transfer of power to the electrical contact structure if the cartridge receiving portion is moved towards the second surface of the housing. An electronic vaping device may include a cartridge detachably coupled to the cartridge receiving portion.

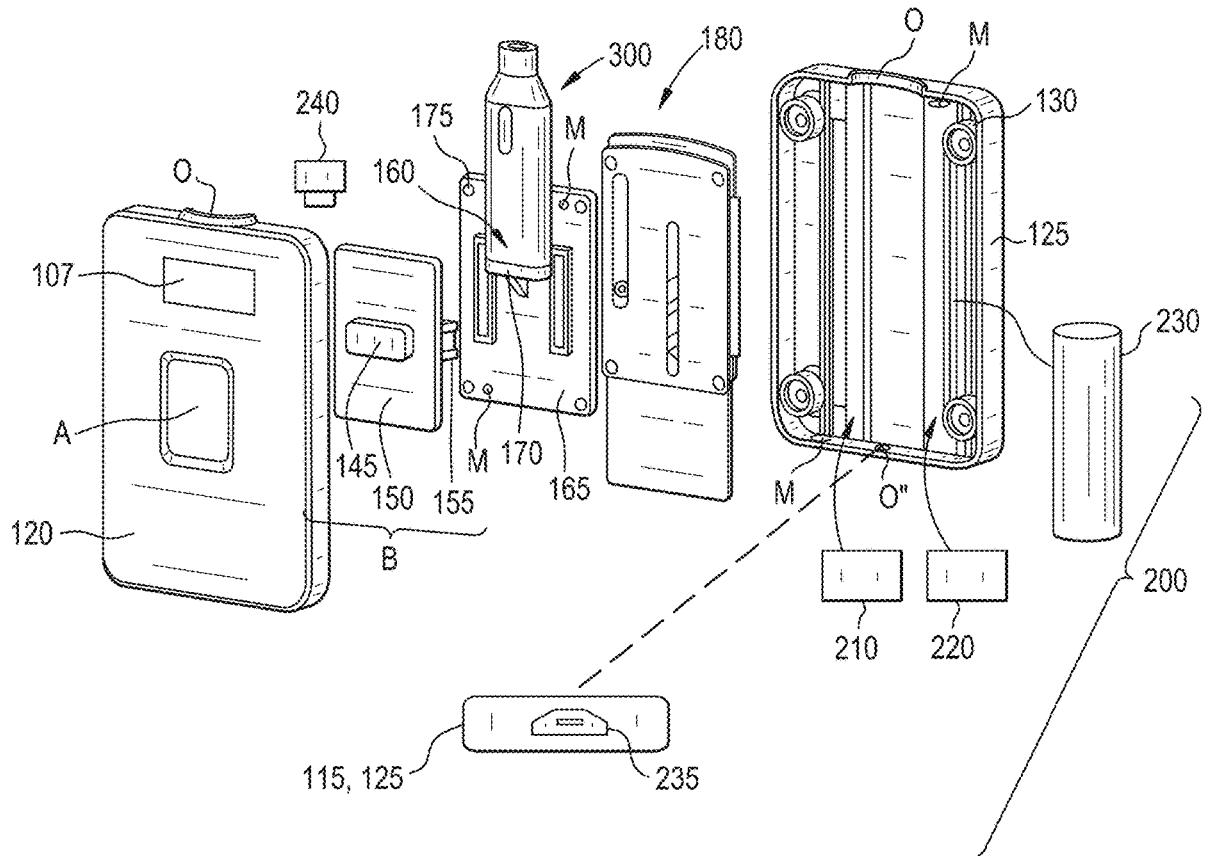

FIG. 1A

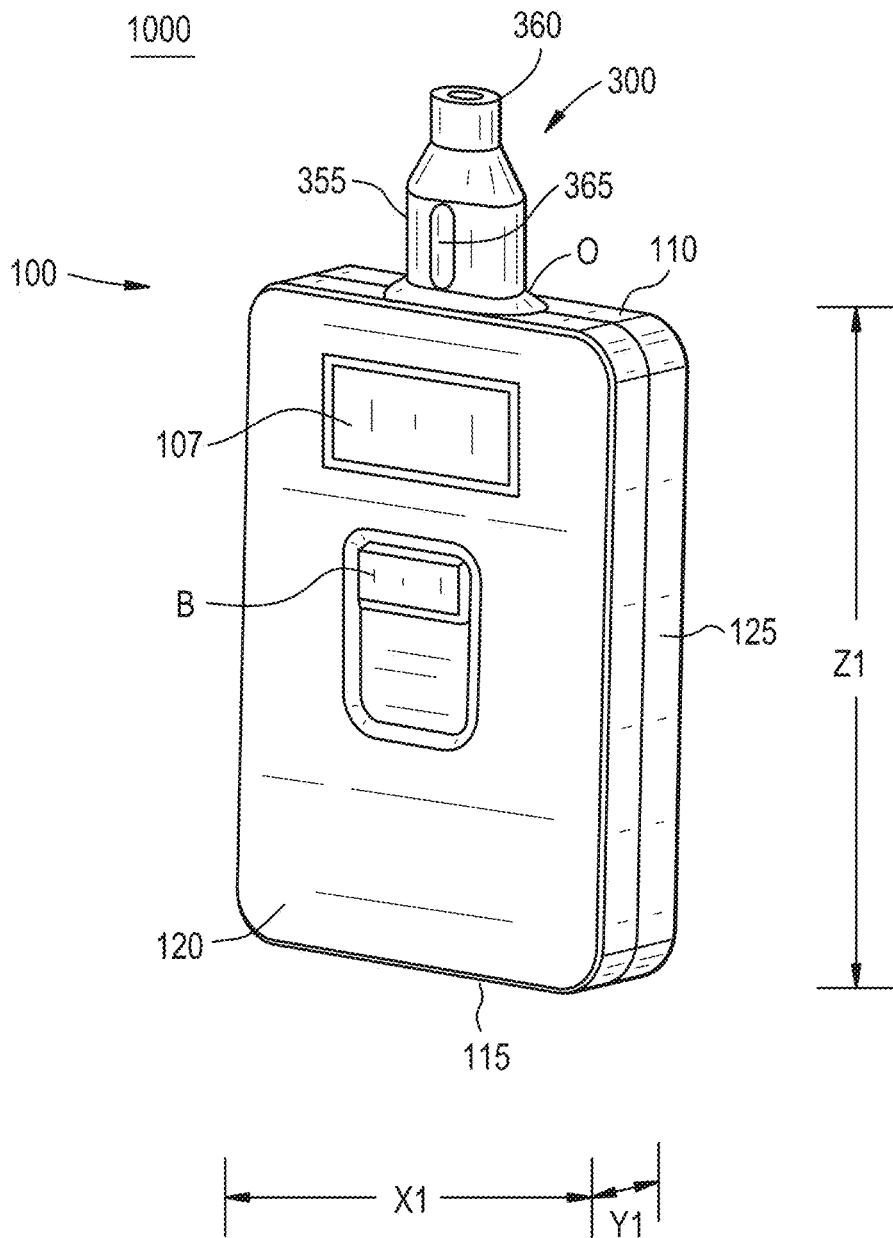

FIG. 1B

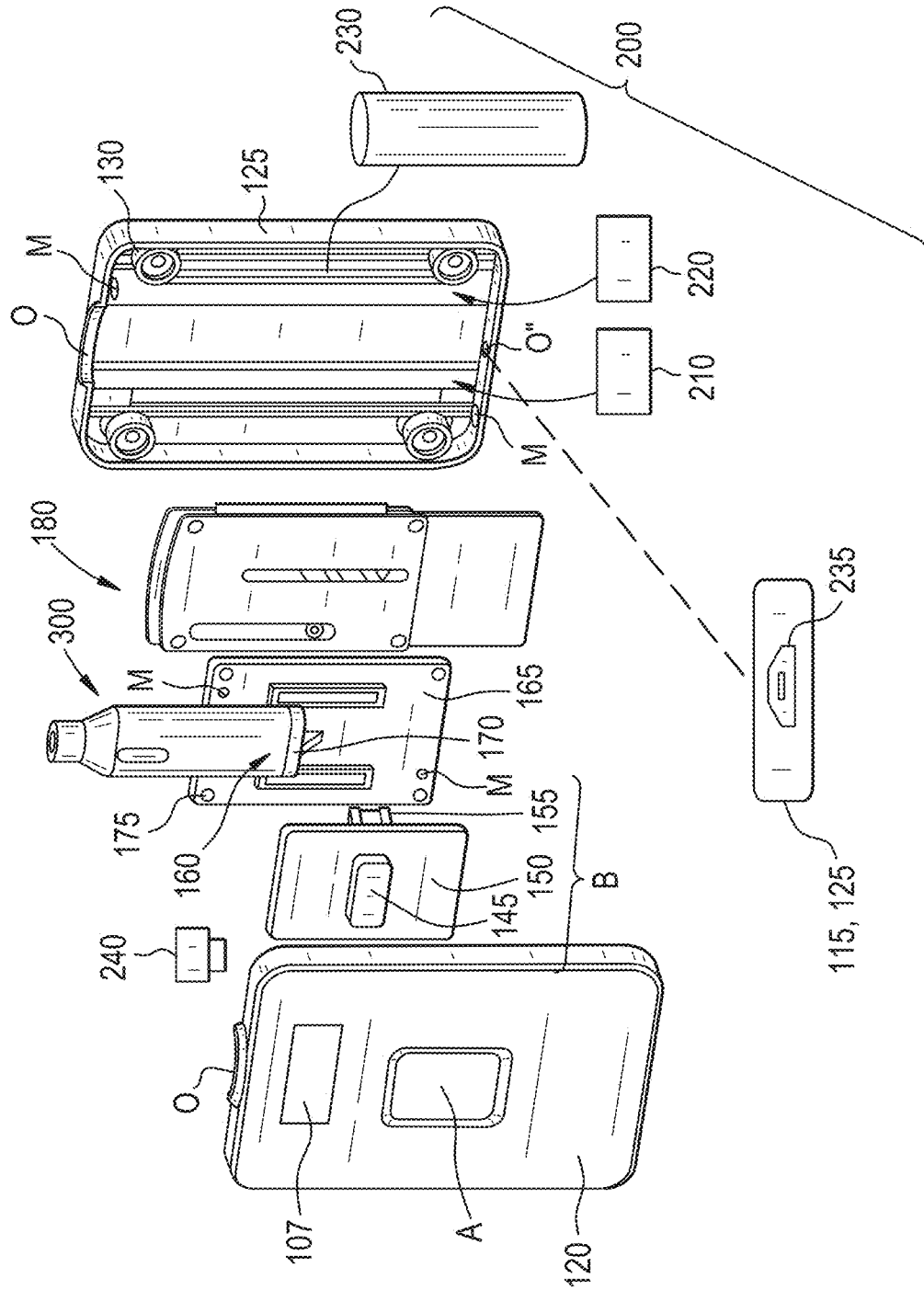

FIG. 1C

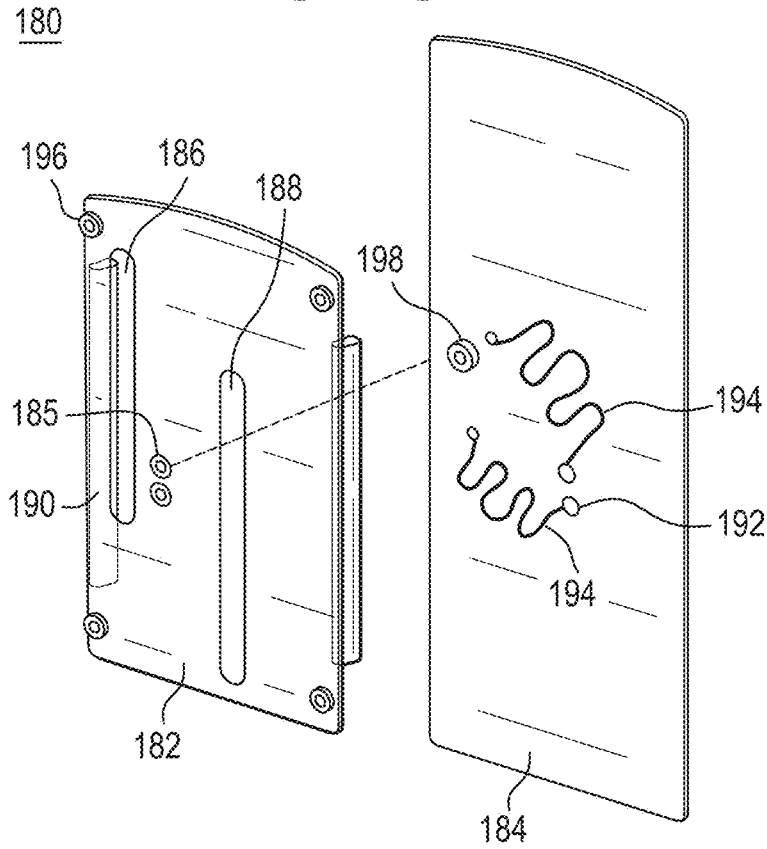

FIG. 1D

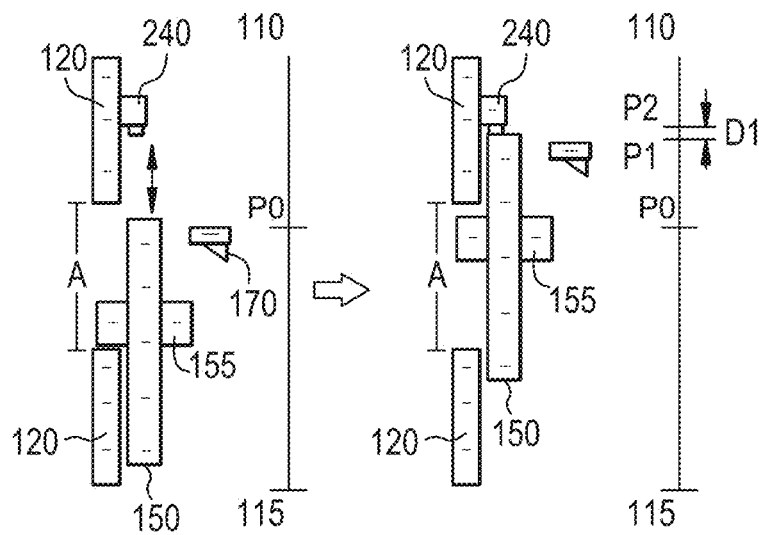

FIG. 1E

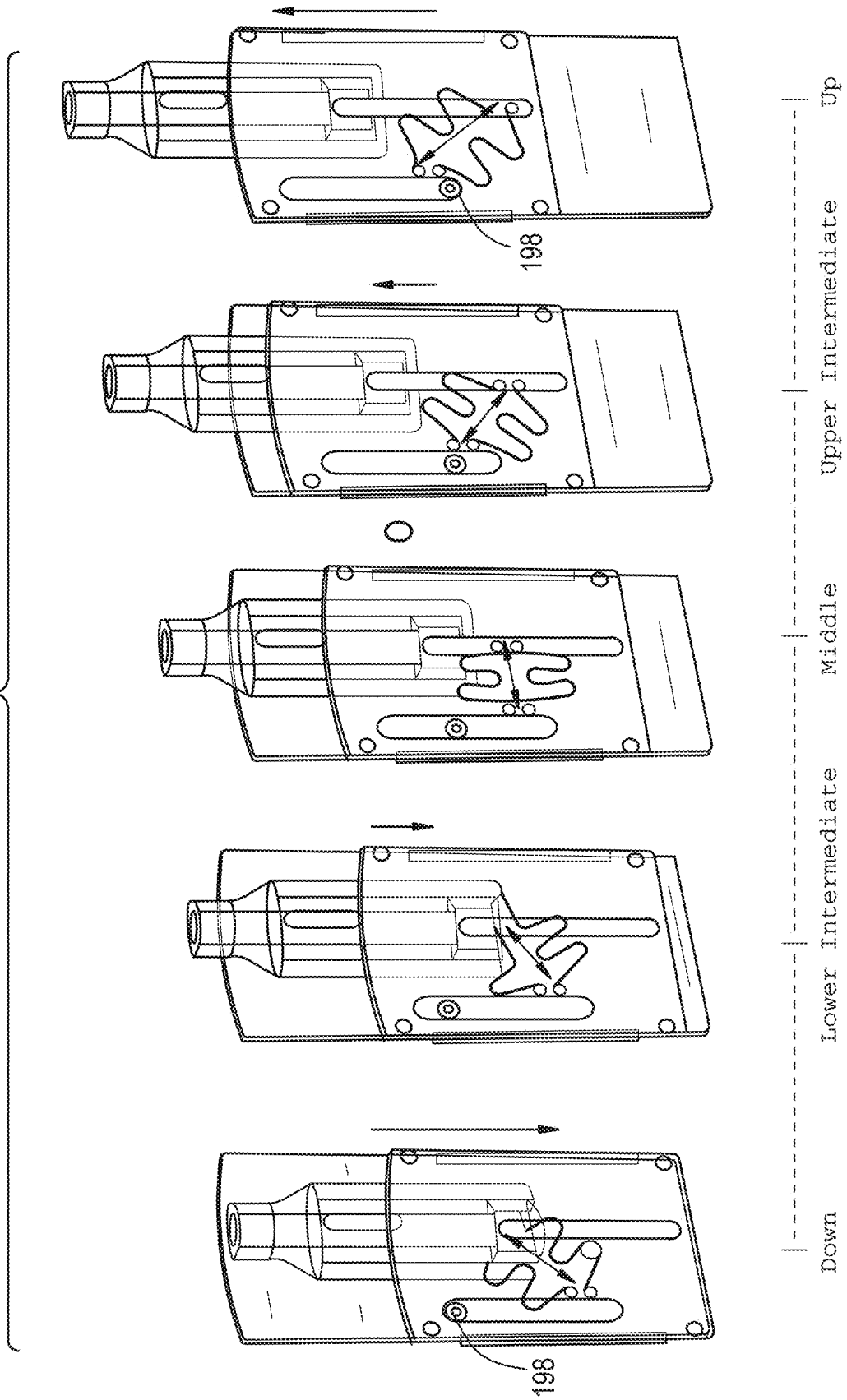

FIG. 1F

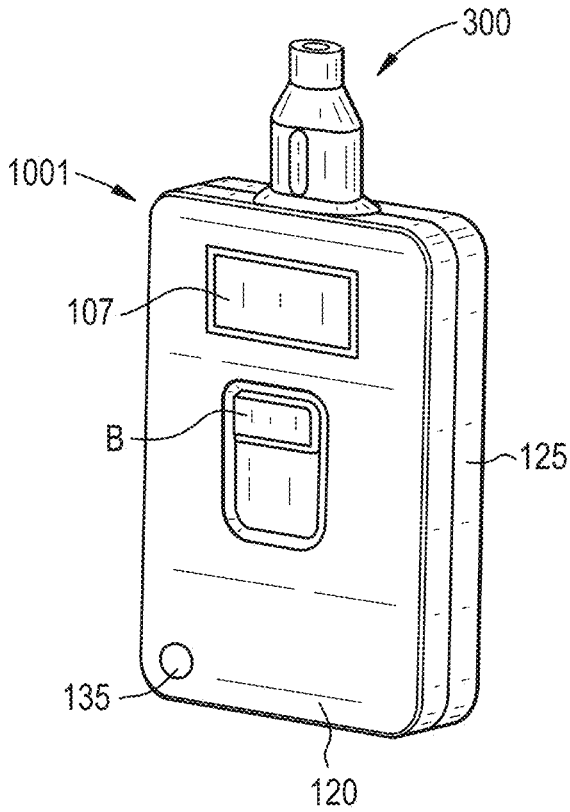

FIG. 1G

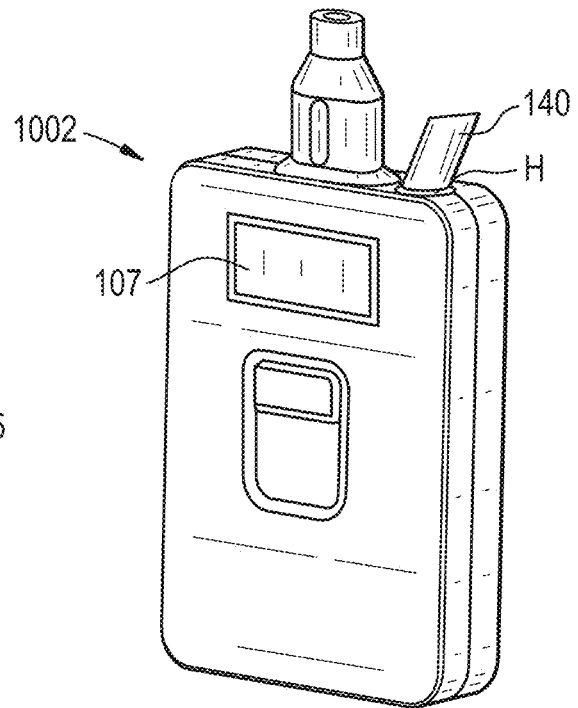

FIG. 1H

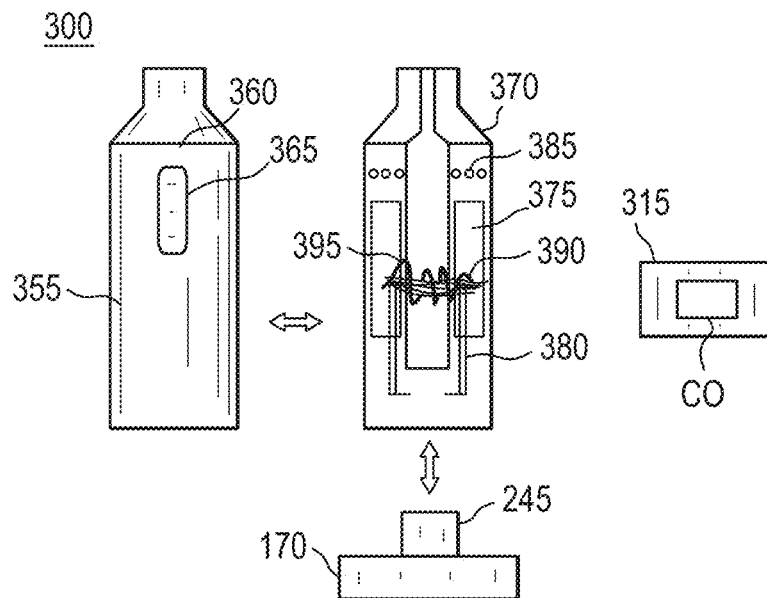

FIG. 2A

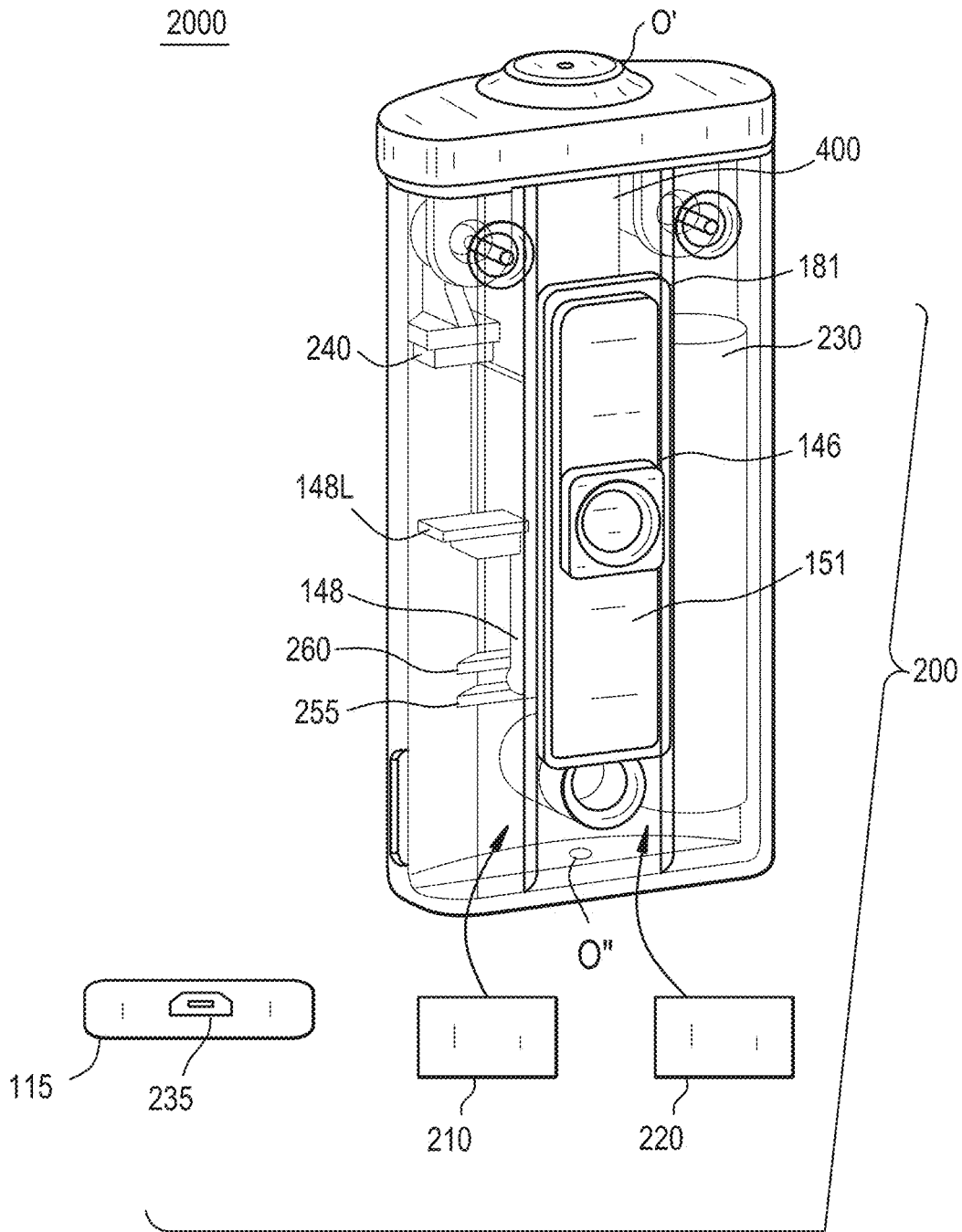

FIG. 2B

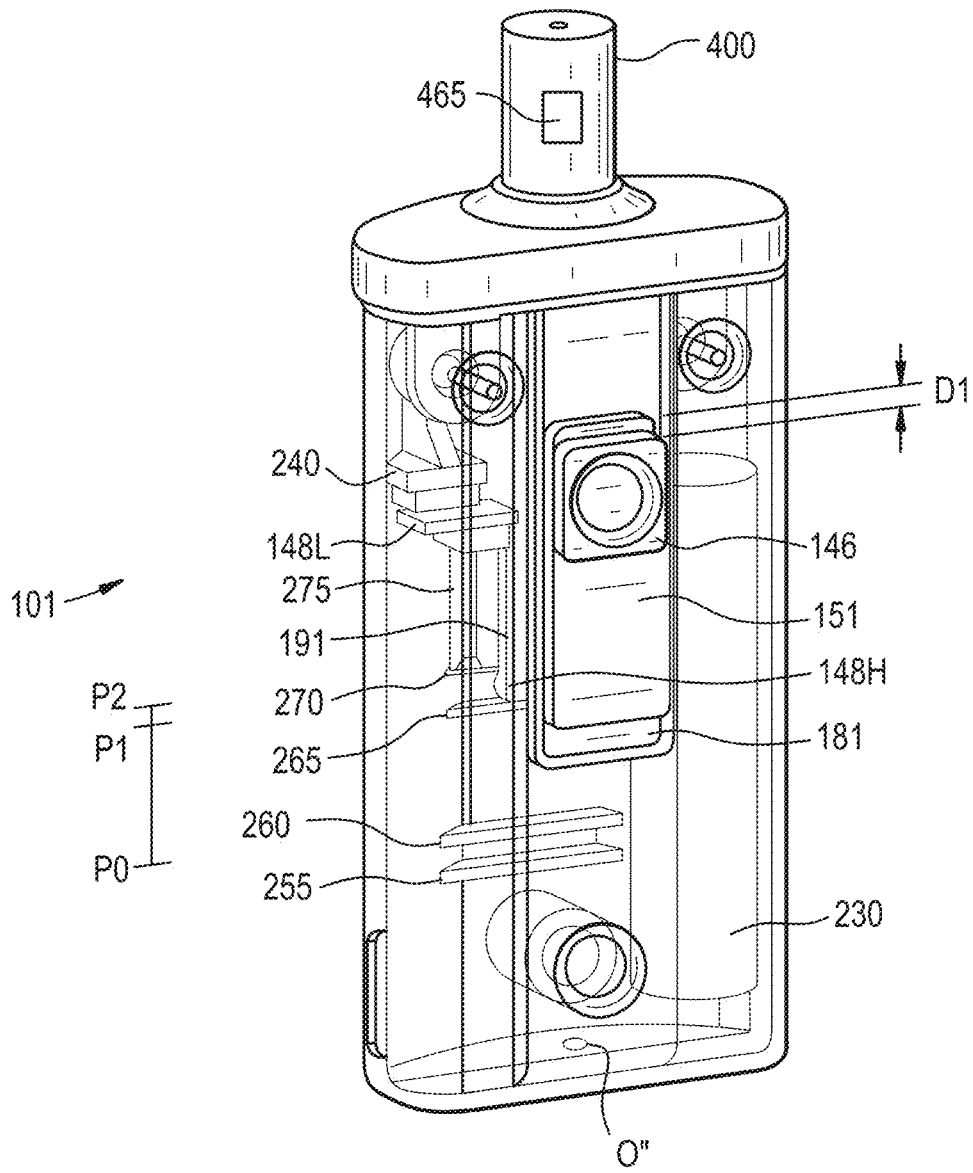

FIG. 2D

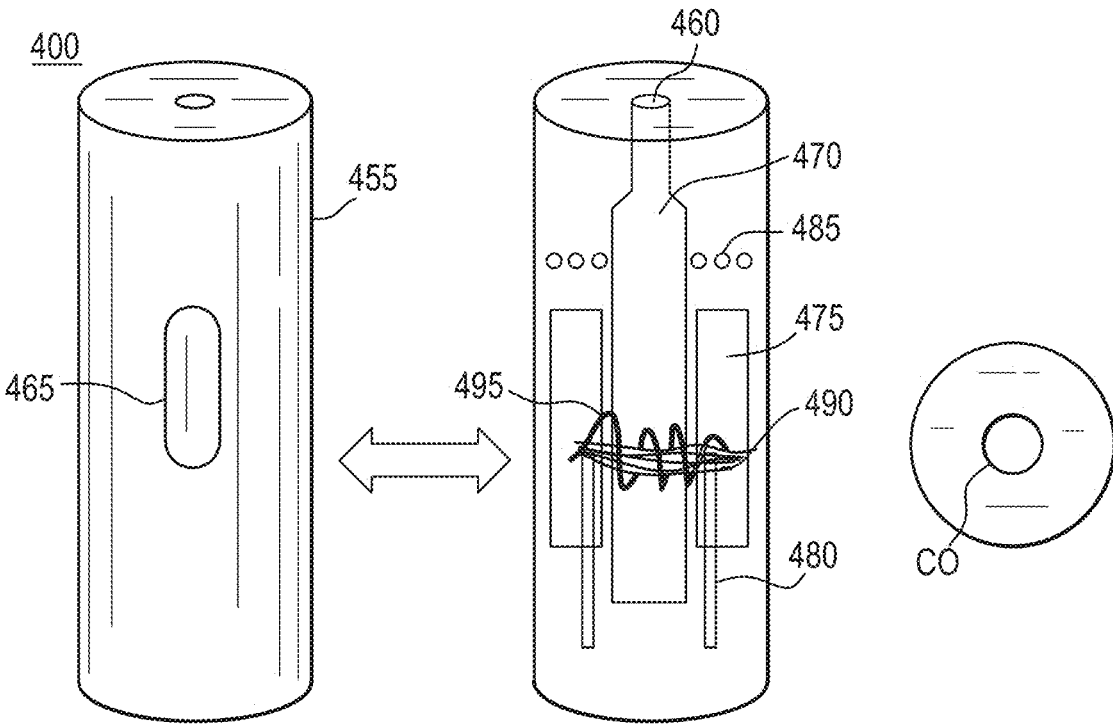

FIG. 3A

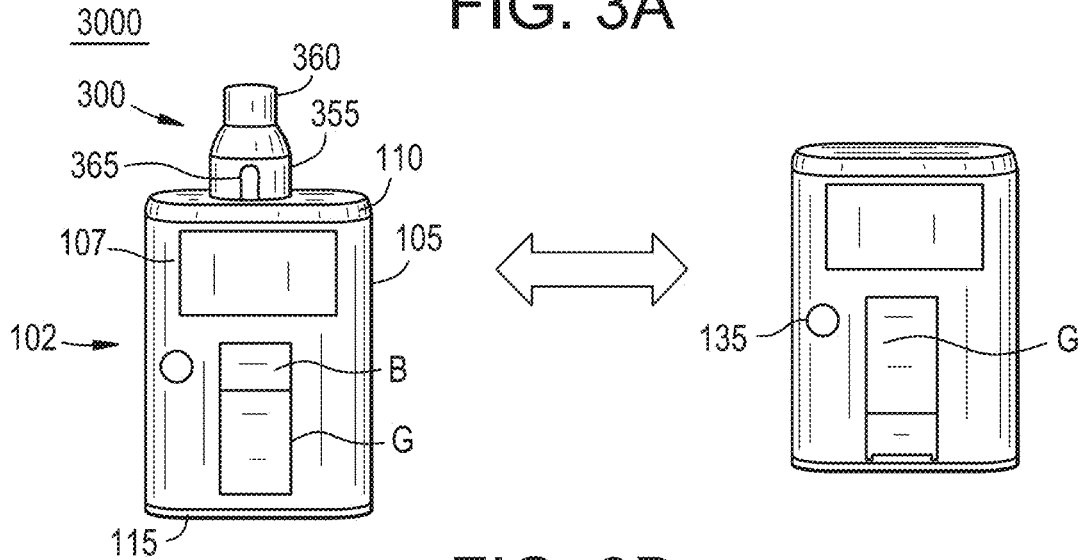

FIG. 3B

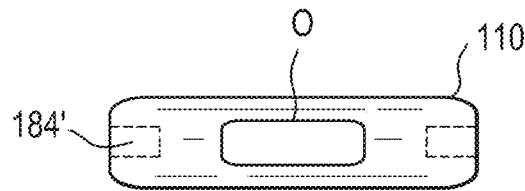

FIG. 3C

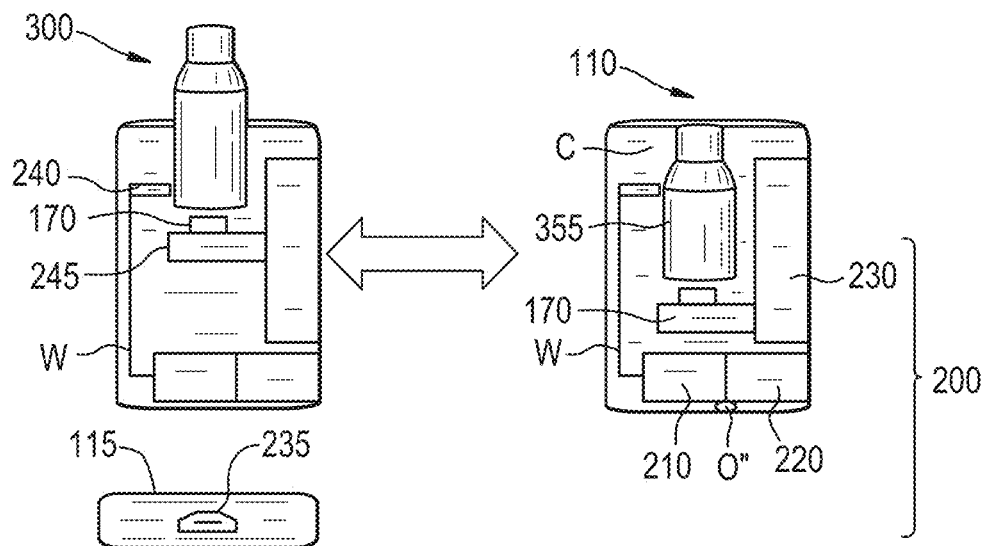

FIG. 3D

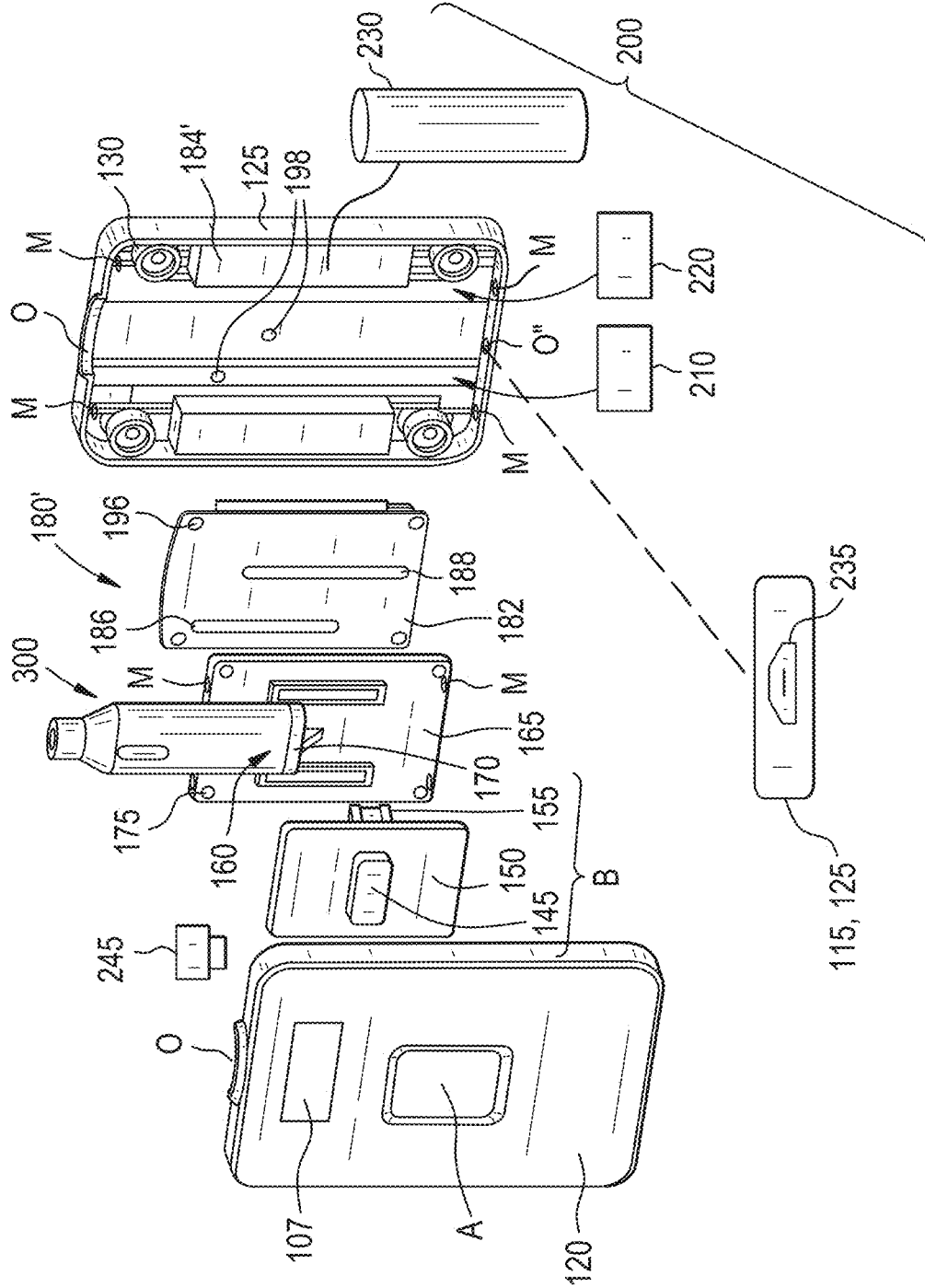

FIG. 4

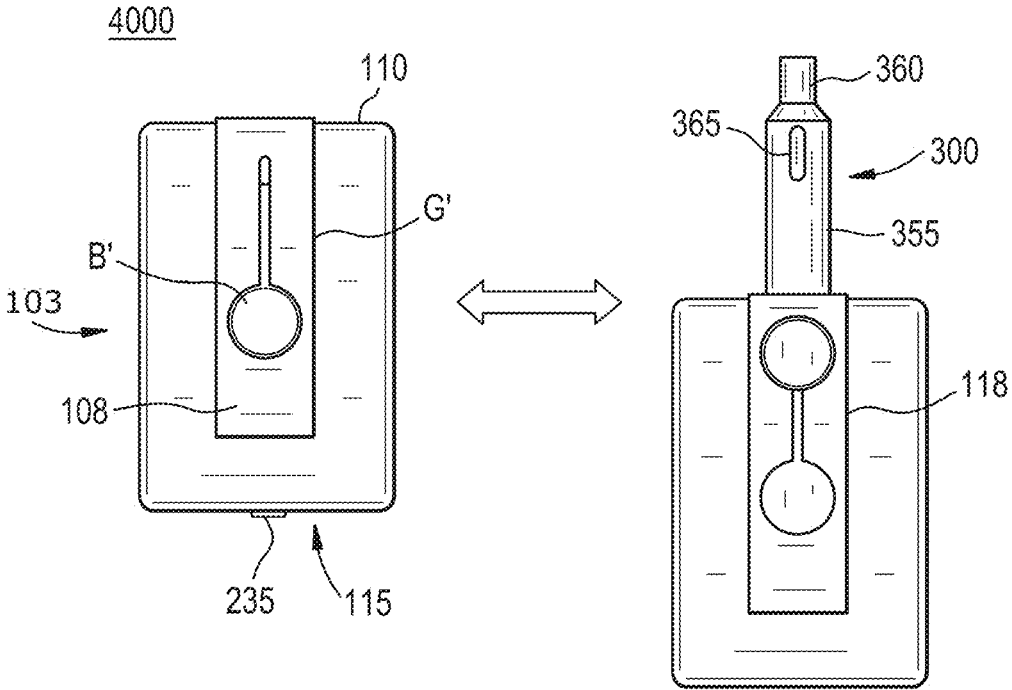

FIG. 5A

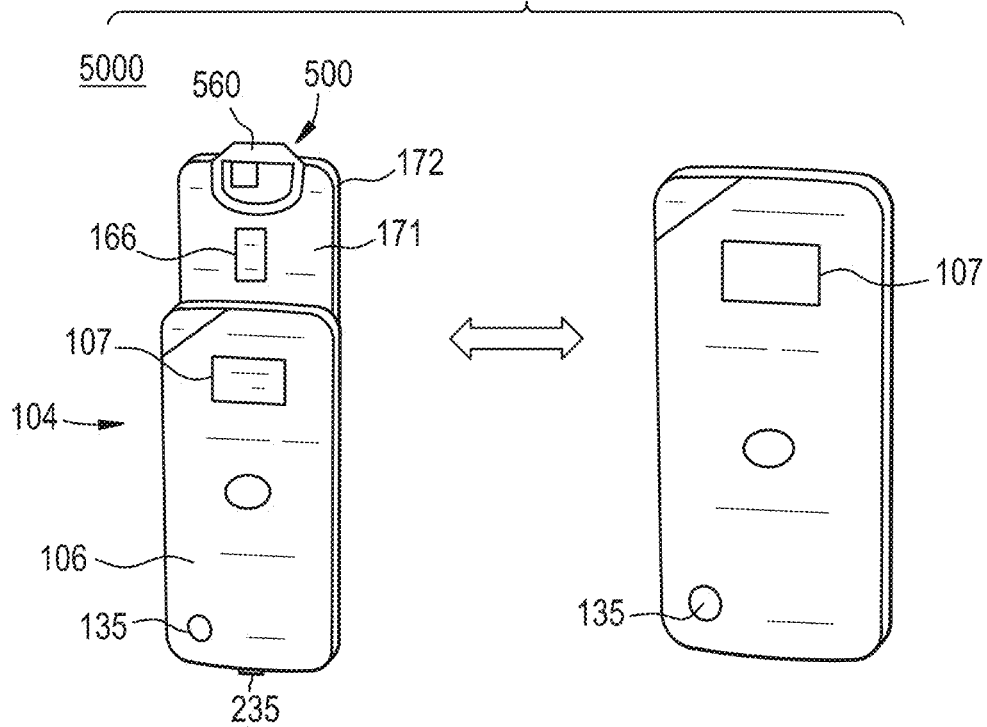

FIG. 5B

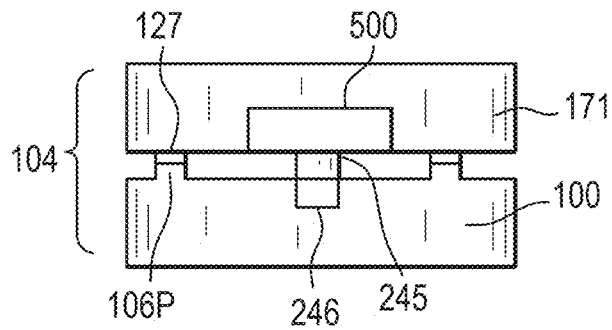

FIG. 5C

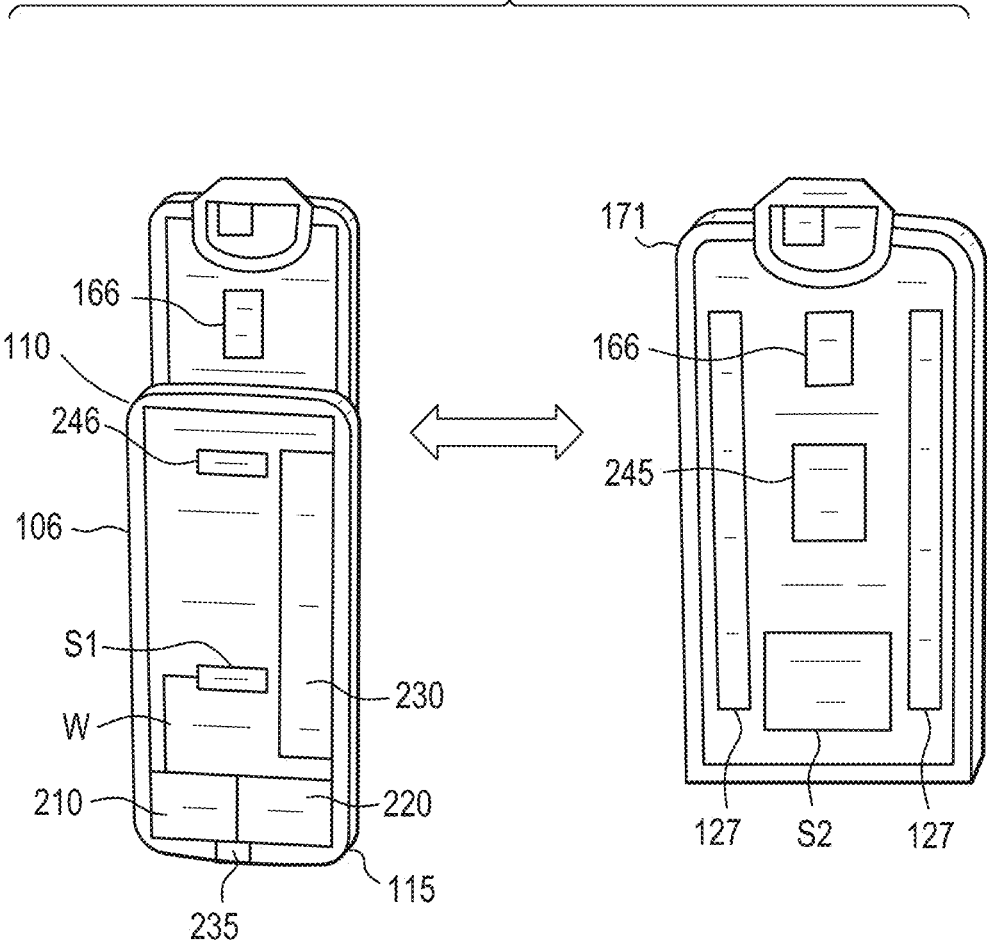

FIG. 6A

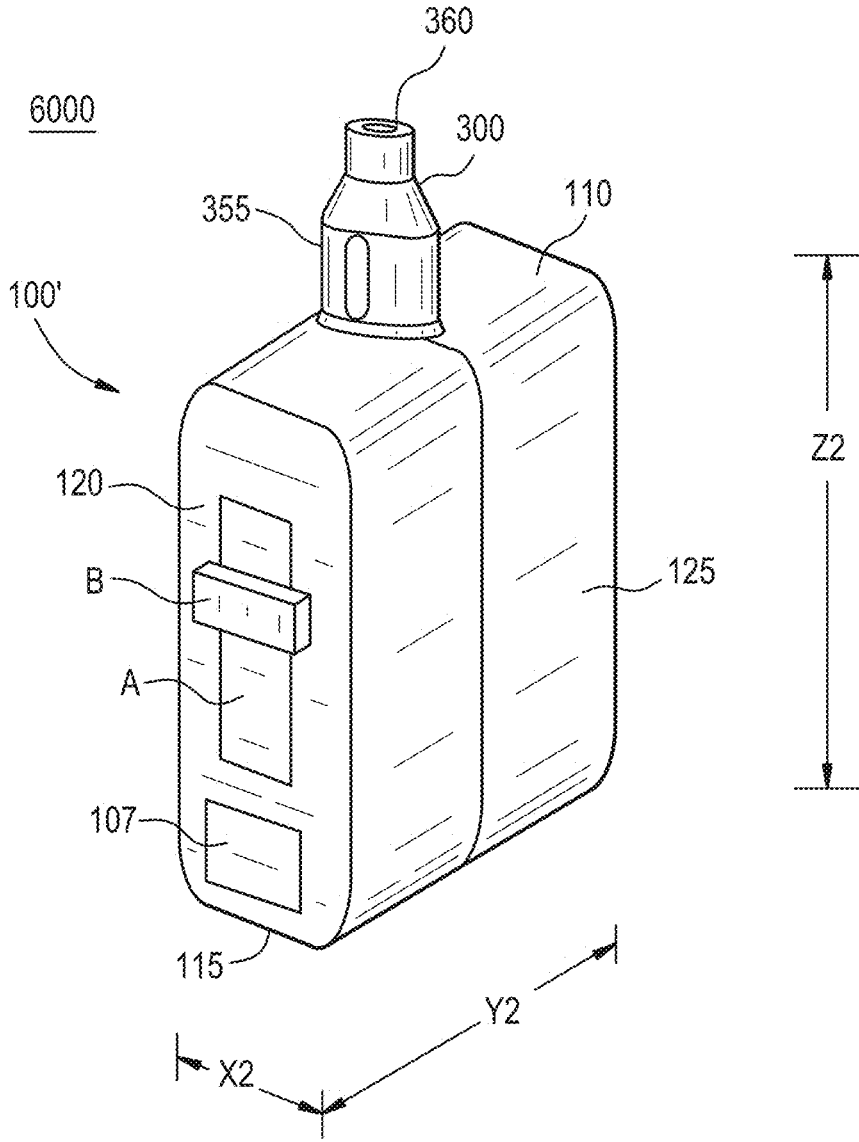

FIG. 6B

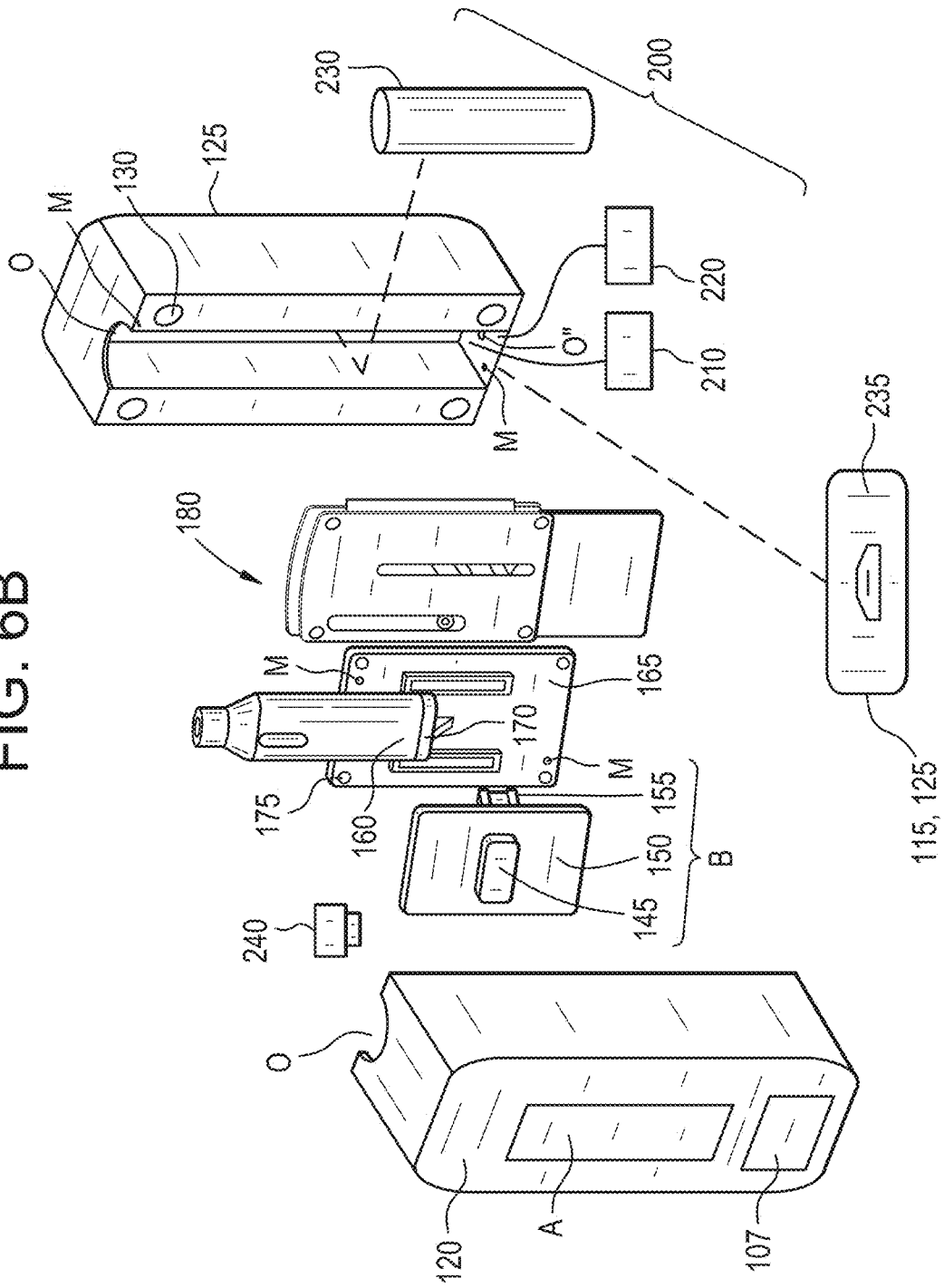
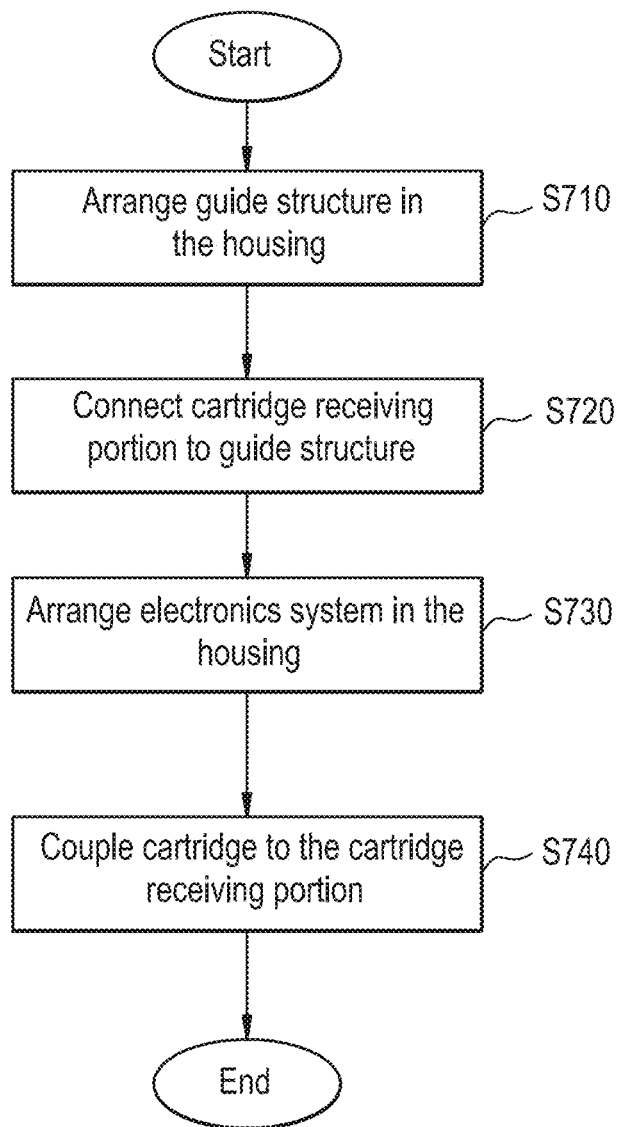

FIG. 7



E-VAPING DEVICE INCLUDING E-VAPING CASE WITH SLIDING MECHANISM FOR INITIATING VAPOR GENERATION

CROSS-REFERENCE TO RELATED APPLICATION

[0001] This application is a continuation of U.S. application Ser. No. 16/989,087, filed Aug. 10, 2020, which is a continuation of U.S. application Ser. No. 15/390,811, filed Dec. 27, 2016, the entire contents of each of which are hereby incorporated by reference.

BACKGROUND

Field

[0002] The present disclosure generally relates to a case for an electronic vaping device and/or more particularly to an e-vaping case including a sliding mechanism for initiating vapor generation and/or an electronic vaping device including the e-vaping case.

Related Art

[0003] An electronic vaping device (also referred to as e-vaping device) may be used to generate a vapor from a pre-vapor formulation. The vapor may be withdrawn from the electronic vaping device by applying a negative pressure to a mouthpiece of the electronic vaping device. The pre-vapor formulation may include a nicotine-containing material, a liquid (e.g., water), and a vapor former. The pre-vapor formulation may further include one or more flavoring additives.

[0004] An electronic vaping device may include a power source and a cartridge. The power source may be a battery section. The cartridge may include a reservoir for holding the pre-vapor formulation and a heater for vaporizing the pre-vapor formulation to produce a vapor. The electronic vaping device may include a pressure sensor. The heater may be activated when the pressure sensor detects a negative pressure has been applied to the mouthpiece of the electronic vaping device.

SUMMARY

[0005] At least one example embodiment relates to an e-vaping case and/or an electronic vaping device including the e-vaping case.

[0006] In an example embodiment, an e-vaping case includes a housing, a guide structure, a cartridge receiving portion connected to the guide structure, and an electronics system in the housing. The guide structure extends between a first surface of the housing and a second surface of the housing. The cartridge receiving portion is configured to be moved along the guide structure between the first surface and the second surface of the housing. The electronics system includes a power supply that is configured to initiate a transfer of power to an electrical contact structure if the cartridge receiving portion is moved towards the first surface of the housing to at least a first position of the housing. The electronics system is configured to interrupt the transfer of power to the electrical contact structure if the cartridge receiving portion is moved towards the second surface of the housing.

[0007] The guide structure may be a sliding mechanism in the housing. The housing may define a cavity. The electron-

ics system may be in the cavity. The sliding mechanism may include a first plate, tracks, and a second plate in the housing. The tracks may connect the first plate to the second plate. The cartridge receiving portion may be connected to the first plate, and the cartridge receiving portion may be configured to move bi-directionally between the first and second surfaces of the housing via the tracks.

[0008] The e-vaping case may further include a button attached to the housing. The button may be electrically connected to the electronics system. The electronics system may be configured to transfer power to the electrical contact structure using the power supply if the cartridge receiving portion is positioned at the first position of the housing and the button is pressed.

[0009] The e-vaping case may further include a switch sensor in the housing and a button structure connected to the cartridge receiving portion. The button structure may be configured to contact the switch sensor if the cartridge receiving portion is moved to the first position in the housing. The switch sensor may be configured to depress momentarily if the cartridge receiving portion is moved past the first position to a second position in the housing. The second position in the housing may be closer to the first surface of the housing than the first position in the housing. The switch sensor may be configured to snap back to the first position of the housing after being depressed momentarily.

[0010] The electronics system may be configured to initiate the transfer of power to the electrical contact structure if the position of the button structure is adjusted to depress the switch sensor a plurality of times within a threshold period.

[0011] The electronics system may be configured to terminate the transfer of power to the electrical contact structure using the power supply if the button is pressed longer than a threshold amount of time.

[0012] The e-vaping case may not include a puff sensor.

[0013] An electronic vaping device may include the e-vaping case described above and a cartridge on the cartridge receiving portion. The cartridge may be configured to be detachably coupled to the cartridge receiving portion and to be electrically connected to the electrical contact structure, and the electronics system may include the electrical contact structure.

[0014] According to an example embodiment, a method of making an e-vaping case includes arranging a guide structure between a first surface of a housing and a second surface of the housing, connecting a cartridge receiving portion to the guide structure, and arranging an electronics system in the housing. The cartridge receiving portion is configured to be moved along the guide structure between the first surface and the second surface of the housing. The electronics system includes a power supply that is configured to initiate a transfer of power to an electrical contact structure if the cartridge receiving portion is moved towards the first surface of the housing to at least a first position of the housing. The electronics system is configured to interrupt the transfer of power to the electrical contact structure if the cartridge receiving portion is moved towards the second surface of the housing.

[0015] According to an example embodiment, a sliding mechanism includes a first plate, a guide member, a stopper, and tracks. The first plate defines a first opening and a second opening that are spaced apart from each other. The stopper is attached to the guide member. The tracks engage

sides of the first plate to edges of the guide member. The stopper extends through the first opening. The first plate is configured to move bi-directionally via the tracks.

BRIEF DESCRIPTION OF THE DRAWINGS

[0016] The above and other features and advantages of example embodiments will become more apparent by describing in detail, example embodiments with reference to the attached drawings. The accompanying drawings are intended to depict example embodiments and should not be interpreted to limit the intended scope of the claims. The accompanying drawings are not to be considered as drawn to scale unless explicitly noted.

[0017] FIG. 1A is a perspective view of an electronic vaping device according to an example embodiment;

[0018] FIG. 1B is an exploded view of the electronic vaping device in FIG. 1A;

[0019] FIG. 1C is perspective view of a sliding mechanism in the electronic vaping device in FIG. 1A;

[0020] FIG. 1D is a side view illustrating a method of operating the electronic vaping device in FIG. 1A;

[0021] FIG. 1E illustrates perspective views of adjusting the sliding mechanism in the electronic vaping device in FIG. 1A;

[0022] FIG. 1F is a perspective view of an electronic vaping device according to an example embodiment;

[0023] FIG. 1G is a perspective view of an electronic vaping device according to an example embodiment;

[0024] FIG. 1H is a sectional view of a cartridge in the electronic vaping device in FIGS. 1A, 1F, and/or 1G;

[0025] FIGS. 2A and 2B are transparent views of an electronic vaping device according to an example embodiment;

[0026] FIG. 2C is an exploded view of the electronic vaping device in FIGS. 2A and 2B;

[0027] FIG. 2D is a sectional view of a cartridge in the electronic vaping device in FIGS. 2A to 2B;

[0028] FIGS. 3A to 3C is a perspective view, plan view, and a sectional view of an electronic vaping device according to an example embodiment;

[0029] FIG. 3D is an exploded view of the electronic vaping device in FIGS. 3A to 3C;

[0030] FIG. 4 is a front view of an electronic vaping device according to an example embodiment;

[0031] FIGS. 5A to 5C are a perspective view, a plan view, and a sectional view of an electronic vaping device according to an example embodiment;

[0032] FIG. 6A is a perspective view of an electronic vaping device according to an example embodiment;

[0033] FIG. 6B is an exploded view of the electronic vaping device in FIG. 6A; and

[0034] FIG. 7 is a flow chart illustrating a method of making an electronic vaping device according to an example embodiment.

DETAILED DESCRIPTION

[0035] Some detailed example embodiments are disclosed herein. However, specific structural and functional details disclosed herein are merely representative for purposes of describing example embodiments. Example embodiments may, however, be embodied in many alternate forms and should not be construed as limited to only the embodiments set forth herein.

[0036] Accordingly, while example embodiments are capable of various modifications and alternative forms, embodiments thereof are shown by way of example in the drawings and will herein be described in detail. It should be understood, however, that there is no intent to limit example embodiments to the particular forms disclosed, but to the contrary, example embodiments are to cover all modifications, equivalents, and alternatives falling within the scope of example embodiments. Like numbers refer to like elements throughout the description of the figures.

[0037] It should be understood that when an element or layer is referred to as being “on,” “connected to,” “coupled to,” or “covering” another element or layer, it may be directly on, connected to, coupled to, or covering the other element or layer or intervening elements or layers may be present. In contrast, when an element is referred to as being “directly on,” “directly connected to,” or “directly coupled to” another element or layer, there are no intervening elements or layers present. Like numbers refer to like elements throughout the specification. As used herein, the term “and/or” includes any and all combinations of one or more of the associated listed items.

[0038] It should be understood that, although the terms first, second, third, etc. may be used herein to describe various elements, components, regions, layers and/or sections, these elements, components, regions, layers, and/or sections should not be limited by these terms. These terms are only used to distinguish one element, component, region, layer, or section from another region, layer, or section. Thus, a first element, component, region, layer, or section discussed below could be termed a second element, component, region, layer, or section without departing from the teachings of example embodiments.

[0039] Spatially relative terms (e.g., “beneath,” “below,” “lower,” “above,” “upper,” and the like) may be used herein for ease of description to describe one element or feature’s relationship to another element(s) or feature(s) as illustrated in the figures. It should be understood that the spatially relative terms are intended to encompass different orientations of the device in use or operation in addition to the orientation depicted in the figures. For example, if the device in the figures is turned over, elements described as “below” or “beneath” other elements or features would then be oriented “above” the other elements or features. Thus, the term “below” may encompass both an orientation of above and below. The device may be otherwise oriented (rotated 90 degrees or at other orientations) and the spatially relative descriptors used herein interpreted accordingly.

[0040] The terminology used herein is for the purpose of describing various embodiments only and is not intended to be limiting of example embodiments. As used herein, the singular forms “a,” “an,” and “the” are intended to include the plural forms as well, unless the context clearly indicates otherwise. It will be further understood that the terms “includes,” “including,” “comprises,” and/or “comprising,” when used in this specification, specify the presence of stated features, integers, steps, operations, elements, and/or components, but do not preclude the presence or addition of one or more other features, integers, steps, operations, elements, components, and/or groups thereof.

[0041] Example embodiments are described herein with reference to cross-sectional illustrations that are schematic illustrations of idealized embodiments (and intermediate structures) of example embodiments. As such, variations

from the shapes of the illustrations as a result, for example, of manufacturing techniques and/or tolerances, are to be expected. Thus, example embodiments should not be construed as limited to the shapes of regions illustrated herein but are to include deviations in shapes that result, for example, from manufacturing. Thus, the regions illustrated in the figures are schematic in nature and their shapes are not intended to illustrate the actual shape of a region of a device and are not intended to limit the scope of example embodiments.

[0042] Unless otherwise defined, all terms (including technical and scientific terms) used herein have the same meaning as commonly understood by one of ordinary skill in the art to which example embodiments belong. It will be further understood that terms, including those defined in commonly used dictionaries, should be interpreted as having a meaning that is consistent with their meaning in the context of the relevant art and will not be interpreted in an idealized or overly formal sense unless expressly so defined herein.

[0043] Throughout the illustrative description, the examples, and the appended claims, a numerical value of a parameter, feature, object, or dimension, may be stated or described in terms of a numerical range format. It is to be fully understood that the stated numerical range format is provided for illustrating implementation of the forms disclosed herein, and is not to be understood or construed as inflexibly limiting the scope of the forms disclosed herein.

[0044] Moreover, for stating or describing a numerical range, the phrase “in a range of between about a first numerical value and about a second numerical value,” is considered equivalent to, and means the same as, the phrase “in a range of from about a first numerical value to about a second numerical value,” and, thus, the two equivalently meaning phrases may be used interchangeably.

[0045] When the terms “about” or “substantially” are used in this specification in connection with a numerical value, it is intended that the associated numerical value include a tolerance of $\pm 10\%$ around the stated numerical value unless the context indicates otherwise. Moreover, unless the context indicates otherwise, when reference is made to percentages in this specification, it is intended that those percentages are based on weight, i.e., weight percentages. The expression “up to” includes amounts of zero to the expressed upper limit and all values therebetween. When ranges are specified, the range includes all values therebetween such as increments of 0.1%.

[0046] A pre-vapor formulation is a material or combination of materials that may be transformed into a vapor. For example, the pre-vapor formulation may be a liquid, solid and/or gel formulation including, but not limited to, water, beads, solvents, active ingredients, ethanol, and/or vapor formers such as glycerin and/or propylene glycol. For example, a vapor may be generated from the pre-vaporization formulation by heating the vaporization formulation above a threshold temperature (e.g., a boiling point of the pre-vaporization formulation).

[0047] A vaporizer, vaporizer assembly, vaporizer arrangement may refer to portion of an electronic vaping device (e.g., a wick and coil heater or an integral body) that is configured to generate vapor through the application of heat to a pre-vapor formulation.

[0048] FIG. 1A is a perspective view of an electronic vaping device according to an example embodiment. FIG. 1B is an exploded view of the electronic vaping device in

FIG. 1A. FIG. 1C is perspective view of a sliding mechanism in the electronic vaping device in FIG. 1A.

[0049] Referring to FIG. 1A, according to an example embodiment, an electronic vaping device **1000** may include an e-vaping case **100** and a cartridge **300**. The e-vaping case **100** may include a housing (e.g., a combined structure including the front cover **120** and the rear cover **125**), a guide structure that extends between a first surface **110** (or top surface) of the housing and a second surface **115** (or bottom surface) of the housing, a cartridge receiving portion connected to the guide structure, and an electronics system in the housing. The details of the guide structure are described later with reference to FIGS. 1B and 1C.

[0050] The housing may define an opening **O** at the first surface **110** of the housing. The electronic vaping device **1000** may be formed by inserting the cartridge **300** into the opening of the e-vaping case **100**. The cartridge **300** may include a body portion **355**. The body portion **355** may include a window **365** that is transparent and/or translucent. As a result, contents inside the body portion **355** (e.g., a level a pre-vapor formulation inside the cartridge **300**) may be viewable through window **365**. A button structure **B** may be exposed through an aperture defined by the front cover **120** of the housing. More details related to the cartridge **300** are described later with reference to FIG. 1H.

[0051] The housing (e.g., front cover **120** and rear cover **125**) material is not particularly limited. For example, the housing may be formed of a metal, a metal alloy, wood, a ceramic, a plastic, or a composite material containing a combination thereof. For example, the housing may be formed of polypropylene, polyethylene, polyetheretherketone (PEEK), or polyacetate, but is not limited thereto. The e-vaping case **100** may have an ergonomic size so that the e-vaping case **100** may be hand held. The e-vaping case **100** may have a width that is greater than its thickness. The e-vaping case may have a height that is greater than its width. For example, the e-vaping case **100** may have a width **X1** in a range from about 1.0 to about 4 inches (e.g., about 2.5 cm to about 10.2 cm), a thickness **Y1** in a range from about 0.25 to about 1.00 inches (e.g., about 0.64 cm to about 2.5 cm), and a height **Z1** in a range from about 2 to about 6 inches (e.g., about 5.1 cm to about 15.2 cm), but is not limited thereto.

[0052] An electronics system (see electronics system **200** in FIG. 1B) inside of the e-vaping case **100** may be connected to a display screen **107** (e.g., a liquid-crystal display or a light emitting device display) for displaying information about the electronic vaping device **1000**. The display screen **107** may be attached to an exterior surface of the housing, such as an exterior surface of the front cover **120**.

[0053] Referring to FIG. 1B, the front cover **120** and the rear cover **125** may be connected to each other to define a housing that encloses the button structure **B**, a carrier structure **160**, a sliding mechanism **180**, and an electronics system **200**. Although not illustrated, one side of the front cover **120** that faces the rear cover **125** may include male connecting members that correspond to the positions of the female connecting members **130** on the rear cover **125**. Thus, the front cover **120** and rear cover **125** may be connected to each other by a snap fit connection when the male connecting members of the front cover **120** are inserted into the female connecting members **130** of the rear cover **125**. Additionally, or in the alternative, an adhesive may be used to connect the front cover **120** to the rear cover **125**.

Even though an example is illustrated where the rear cover **125** includes four female connecting members **130** adjacent to corners of the rear cover **125**, example embodiments are not limited to thereto and the number and or respective positions of the female connecting members **130** may vary. Additionally, the positions and number of male connecting members on the front cover **120** may vary according to the number of female connecting members **130**. Also, one of ordinary skill in the art would appreciate that alternative connections besides snap-fit connections may be used to secure the front cover **120** to the rear cover **125**.

[0054] The front cover **120** may define an aperture **A** and part of the opening **O**. The aperture **A** may be spaced apart from the first surface **110**, second surface **115**, and side surfaces of the front cover **120**. The aperture **A** may be between the first surface **110** and the second surface **115** of the housing. For example, the aperture **A** may be centrally formed in the front cover **120**. The rear cover **125** may define another part of the opening **O** such that the front cover **120** and rear cover **125** define the opening together.

[0055] The button structure **B** may include a button protruding portion **145**, a button wall portion **150**, and a button connecting portion **155**. The button wall portion **150** may have a rectangular shape but is not limited thereto. The button protruding portion **145** may protrude from one surface (e.g., front surface) of the button wall portion **150**. The button connecting portion **155** may connect to another surface (e.g., back surface) of the button wall portion **150**. The button structure **B**, and constituent parts thereof, may be formed of a metal, a metal alloy, wood, a ceramic, a plastic, or a composite material containing a combination thereof. For example, the button structure **B** may be formed of polypropylene, polyethylene, polyetheretherketone (PEEK), or polyacetate, but is not limited thereto.

[0056] The carrier structure **160** may include a carrier plate **165** and a cartridge receiving portion **170** connected to the carrier plate **165**. The carrier plate **165** may define holes **175**. In FIG. 1B, an example is shown where the carrier plate **165** defines four holes **175**, but example embodiments are not limited thereto. The carrier plate **165** may define slots at respective sides of the cartridge receiving portion **170**. The button structure **B** may be connected to the carrier plate **165**. For example, the button connecting portion **155** of the button structure **B** may be inserted into the slots defined by the carrier plate **165**. The cartridge receiving portion **170** may be connected to a part of the carrier plate **165** that is between the slots defined by the carrier plate **165**. The cartridge **300** may connect to a top surface of the cartridge receiving portion **170** in order to make an electrical connection. For example, the cartridge **300** may connect to a top surface of the cartridge receiving portion **170** and the electrical contact structure **245** like a phone jack, DC jack, or USB plug, etc. Although not shown in FIG. 1B, electrical leads (see **380** in FIG. 1H) may connect the cartridge **300** to the electronics system **200** through the cartridge receiving portion **170**. Carrier screws may be inserted through the holes **175** to connect the carrier structure **160** to the securing member **196** of the sliding mechanism **180** (see FIG. 1C).

[0057] The carrier structure **160** may be formed of a metal, a metal alloy, wood, a ceramic, a plastic, or a composite material containing a combination thereof. For example, the button structure **B** may be formed of polypropylene, polyethylene, polyetheretherketone (PEEK), or polyacetate, but is not limited thereto. The carrier screws connecting the

carrier plate **165** to the securing member **196** of the sliding mechanism may be formed of a metal or metal alloy. The electrical leads connecting the cartridge **300** to the electronics system **200** may be formed of a metal or metal alloy.

[0058] One or more magnets **M** may be attached to the carrier structure **160**. The magnets **M** attached to the carrier structure **160** may be adjacent to the top and bottom surfaces of the carrier structure **160**, on sidewalls of the carrier structure **160**, or connected to the top and bottom surfaces of the carrier structure **160**. Corresponding magnets **M** may be attached to an inner surface of the rear cover **125** (and/or front cover **120**) adjacent to the top and bottom the rear cover **125** (and/or front cover **120**). The magnets **M** attached to the rear cover **125** (and/or front cover **120**) may have a polarity that is opposite a polarity of the magnets **M** attached to the carrier structure **160**. As a result, if the carrier structure **160** is moved near the first surface **110**, the magnets **M** near the top of the carrier structure **160** may be attracted magnetically to the magnets **M** near the top of the rear cover **125** (and/or front cover **120**). Similarly, if the carrier structure **160** is moved near the second surface **115**, the magnets **M** near the bottom of the carrier structure **160** may be attracted magnetically to the magnets **M** near the bottom of the rear cover **125** (and/or front cover **120**). One of ordinary skill in the art would appreciate that the strength of the magnets **M** may be relatively weak to avoid interfering with the functions of the electronics system **200** and/or to avoid interfering with moving the carrier structure **160** bi-directionally between the first surface **110** and the second surface **115** of the housing. In some example embodiments, the magnets **M** on the carrier structure **160** and the rear cover **125** (and/or front cover **120**) may be omitted.

[0059] The electronics system **200** may include a driving circuit **210**, a controller **220**, a memory (not shown), a power supply **230**, an external device connection structure **235**, and a switch sensor **240**, which may be connected to each other through wires and a bus. The controller **220** may include one or more Central Processing Units (CPUs), digital signal processors (DSPs), one or more circuits, application-specific-integrated-circuits (ASICs), field programmable gate arrays (FPGAs), and/or computers or the like configured as special purpose machines to perform the functions of the controller **220**. The memory may be integrated with the controller **220**. The memory may be a volatile memory device (e.g., DRAM chip) or a non-volatile memory device (e.g., flash memory). The power supply **230** may be a Lithium-ion battery or one of its variants, for example a Lithium-ion polymer battery. Alternatively, the battery may be a Nickel-metal hydride battery, a Nickel cadmium battery, a Lithium-manganese battery, a Lithium-cobalt battery or a fuel cell. The power supply **230** may be rechargeable (e.g., rechargeable) and include circuitry allowing the battery to be chargeable by an external charging device. The controller **220** may be connected to the display screen **107**. In response to commands received from the controller **220**, the display screen **107** may display various operational information about the electronic vaping device **1000**, such as the battery charge level, vapor precursor level, puff count, and various operation error messages transmitted, but example embodiments are not limited thereto.

[0060] The external device connection structure **235** may be connected to an external device (e.g., charger, computer) for charging the power supply **230**. The external device connection structure **235** may also be used to transfer data,

commands, and/or software between the e-vaping case **100** and the external device. The external device connection structure **235** may be a female USB charging structure (e.g., female micro-USB), but example embodiments are not limited thereto. The external device connection structure **235** may be disposed in an opening **O** defined by the bottom of the rear cover **125**.

[0061] Referring to FIG. 1C, the sliding mechanism **180** may include a first plate **182** and a second plate **184**. The second plate **184** may also be referred to as a guide member. A height of the second plate **184** may be slightly less than a height of the rear cover **125**. For example, when the second plate **184** is placed inside the housing (e.g., front cover **120** and rear cover **125** connected to each other), the upper surface of the second plate **184** may be in contact with (or near) an internal surface of the rear cover **125** opposite the first surface **110** and the lower surface of the second plate **184** may be in contact with (or near) an internal surface of the rear cover **125** opposite the second surface **115**. Tracks **190** (e.g., rails structures) may be connected to sides of the first plate **182**. The tracks **190** may engage sides of the first plate **182** to edges of the second plate **184**. The tracks **190** may be formed of a metal or a metal alloy, but are not limited thereto. The first plate **182** and the second plate **184** may be formed of any of the materials described above for forming the front cover **120** and rear cover **125**.

[0062] The first plate **182** may define a first opening **186** and a second opening **188** that are spaced apart from each other in a staggered manner (e.g., spaced apart diagonally from each other). The first and second openings **186** and **188** may be at different heights in the first plate **182**. The first opening **186** may be adjacent to one of the sides of the first plate **182**. Securing members **196** may be connected to the first plate **182**. The securing members **196** may correspond to the positions of the holes **175** in the carrier plate **165** (see FIG. 1B). For example, the securing members **196** may be attached to corner regions of the first plate **182**. Thus, securing members **196** may define threaded holes or recesses. Thus, carrier screws may be inserted through the holes **175** of the carrier plate **165** in order to connect the carrier structure **160** to the first plate **182**.

[0063] The guide structure may include first connection members **185** (e.g., rivets), springs **194**, second connection members **192**, and one or more stoppers **198**. The first connection members **185** may be attached to the first plate **182**. The first connection members **185** may be attached to an area of the first plate between a bottom region of the first opening **186** and a middle region of the second opening **188**. The second connection members **192** may be attached to the second plate **184**. The first connection members **185** may be spaced apart from each other and may connect a first end of the springs **194** to the first plate **182**. Each first end of the springs **194** may be connected to a corresponding one of the first connection member **185**. The springs **194** may extend from the first connection members **185** through the second opening **188** to the second plate **184**. The second connection members **192** may connect a second end of the springs **194** to the second plate **184**. Each second end of the springs **194** may be connected to a corresponding one of the second connection members **192**. The stopper **198** may be attached to the second plate **184** and may extend from the second plate **184** into the first opening **186** of the first plate **182**. The second opening **188** may be spaced apart in a staggered manner from the first opening **186** such that a top region of

the first opening **186** may be closer to a top of the first plate **182** compared to a top region of the second opening **188**. The bottom region of the second opening **186** may be closer to a bottom of the first plate compared to the bottom region of the first opening.

[0064] The first and second openings **186** and **188** may be elongated parallel to the sides of the first plate **182**. A height of the second plate **184** may be greater than a height of the first plate **182**. A width of the first plate **182** may be equal to a width of the second plate **184**. The first plate **182** may be configured to move bi-directionally in a direction parallel to the sides of the first plate **182**. The stopper may be configured to limit a distance the first plate **182** moves bi-directionally by contacting the first plate **182** at a top region of the first opening **186** or a bottom region of the first opening **186**.

[0065] As shown in FIGS. 1B and 1C, the tracks **190** may fit around the sidewalls of the second plate **184** in order to engage and/or connect the first plate **182** to the second plate **184**. The springs **194** may be configured to undergo a compression if the cartridge receiving portion **170** is moved toward the first surface **110** or the second surface **115** of the housing. In an example embodiment, the springs **194** are configured to undergo a compression if the cartridge receiving portion **170** is moved toward a middle of the housing (see FIG. 1E).

[0066] Referring to FIGS. 1A to 1C, the guide structure in the e-vaping case **100** of the electronic vaping device **1000** may be defined by the first plate **182**, tracks **190**, and second plate **184**. When the front cover **120** and rear cover **125** enclose the sliding mechanism **180**, the guide structure may extend between the first surface **110** and the second surface **115** of the housing (e.g., front cover **120** connected to rear cover **125**). The cartridge receiving portion **170** of the carrier structure **160** may be connected to the first plate **182** of the guide structure using carrier screws through the holes **175** to connect the carrier plate **165** to the securing members **196** on the first plate **182**. The cartridge receiving portion **170** may be configured to be moved along the guide structure (e.g., first plate **182**, tracks **190**, and second plate **184**) between the first surface **110** and the second surface **115** of the housing (e.g., front cover **120** connected to the rear cover **125**).

[0067] The cartridge receiving portion **170** may be configured to move bi-directionally between the first and second surfaces **110** and **115** of the housing via the tracks **190**. For example, if the button structure **B** is connected to the carrier structure **160** and the carrier structure **160** is connected to the sliding mechanism **180**, and the housing (e.g., front cover **120** and rear cover **125**) encloses the button structure **B**, carrier structure **160**, and sliding mechanism **180**, the protruding portion **145** of the button structure **B** may be manually adjusted through the aperture **A** of the front cover **120**.

[0068] FIG. 1D is a side view illustrating a method of operating the electronic vaping device in FIG. 1A.

[0069] Referring to FIGS. 1A to 1D, the switch sensor **240** may be positioned in the housing (e.g., front cover **120** connected to rear cover **125**) over the button wall portion **150** of the button structure **B**. The button structure **B** may be positioned in the housing so the button protruding portion **145** extends into the aperture **A** and faces an outside of the housing. The button connecting portion **155** may connect the button structure **B** to the carrier structure **160**.

[0070] The cartridge receiving portion 170 may be configured to be moved between the first and second surfaces 110 and 115 of the housing by adjusting a position of the button protruding portion 145 in the aperture A such that moving the button protruding portion 145 towards the first surface 110 of the housing corresponds to moving the cartridge receiving portion 170 towards the first surface 110 of the housing and moving the button protruding portion towards the second surface 115 of the housing corresponds to moving the cartridge receiving portion 170 towards the second surface of the housing. As shown in FIG. 1D, when the button protruding portion 145 is near a bottom of the aperture A, the cartridge receiving portion 170 may be at a zero position P0 in the housing.

[0071] The aperture A may include a first border (e.g., top border) adjacent to the first surface 110 of the housing and a second border (e.g., bottom border) adjacent to the second surface 115 of the housing. The aperture A may include third and fourth borders (e.g., left and right borders) that connect the first and second borders to each other. The cartridge receiving portion 170 may be configured to be moved between the first and second surfaces 110 and 115 of the housing by adjusting a position of the button protruding portion 145 in the aperture A such that moving the button protruding portion 145 towards the first surface 110 of the housing corresponds to moving the cartridge receiving portion 170 towards the first surface 110 of the housing and moving the button protruding portion 145 towards the second surface 115 of the housing corresponds to moving the cartridge receiving portion 170 towards the second surface 115 of the housing. The first and second borders of the aperture A may limit a distance that the button protruding portion 145 may be adjusted in the aperture A.

[0072] The power supply 230 of the electronics system 200 may be configured to initiate a transfer of power to an electrical contact structure (see e.g., the electrical contact structure 245 in the FIG. 1G) if the cartridge receiving portion 170 is moved towards the first surface 110 of the housing to at least a first position P1 of the housing. The first position P1 of the housing may be a first height that is vertically between the first surface 110 and the second surface 115 of the housing. The electronics system 200 may be configured to interrupt the transfer of power to the electrical contact structure if the cartridge receiving portion 170 is moved towards the second surface 115 of the housing.

[0073] As shown in FIG. 1D, the button structure, for example the button wall portion 150 of the button structure B (see FIG. 1B), may be configured to contact the switch sensor 240 if the cartridge receiving portion 170 is moved to the first position P1 in the housing. For example, manually pushing the button protruding portion 145 towards a top of the aperture A may move the button wall portion 150 and the cartridge receiving portion 170 towards the first surface 110 because the button protruding portion 145 may be connected to the cartridge receiving portion 170 through the button wall portion 150, button connecting portion 155, and the carrier plate 165. The switch sensor 240 may be configured to depress momentarily if the cartridge receiving portion 170 is moved past the first position P1 to a second position P2 in the housing. The second position P2 in the housing may be closer to the first surface 110 of the housing than the first position P1 in the housing. A travel distance D1 between the first position P1 and the second position P2 may be in a range of about $\frac{1}{16}$ of an inch to about $\frac{1}{4}$ of an inch (e.g.,

about 1.6 mm to about 6.4 mm), but is not limited thereto. The switch sensor 240 may be configured to snap back after being depressed momentarily. When the switch sensor 240 snaps back, the button wall portion 150 may be moved towards the second surface 115 of the housing. When the button wall portion 150 moves towards the second surface 115, the button protruding portion 145 and cartridge receiving portion 170 may also be moved towards the second surface 115 of the housing because the button protruding portion 145 and cartridge receiving portion 170 may be connected to the button wall portion 150. Although FIG. 1D illustrates an example where the button wall portion 150 may contact the switch sensor 240. Alternatively, the switch sensor 240 may be positioned so that parts of the carrier structure 160 (e.g., the carrier plate 165) or other structures may contact the switch sensor 240 if the cartridge receiving portion 170 is moved to the first position P1 in the housing.

[0074] The switch sensor 240 may be embodied in many different ways. For example, the switch sensor 240 may include a spring so the switch sensor 240 may be configured to be depressed and to snap back after being depressed momentarily. Also, the switch sensor 240 may include a circuit for sensing when the switch sensor 240 is depressed and/or not depressed. However, example embodiments are not limited thereto.

[0075] In an example embodiment, the electronics system 200 may be configured to initiate the transfer of power to the electrical contact structure (see e.g., the electrical contact structure 245 in FIG. 1H) if the position of the button structure B is adjusted to depress the switch sensor 240 a plurality of times within a threshold period (e.g., 3 or more times within a 5 second period).

[0076] In an example embodiment, the electronics system 200 may be configured to automatically transfer power from the power supply 230 to the electrical contact structure 245 if the cartridge receiving portion 170 is positioned at the first position P1. The e-vaping case may be formed without a puff sensor.

[0077] FIG. 1E illustrates perspective views of adjusting the sliding mechanism in the electronic vaping device in FIG. 1A.

[0078] Referring to FIGS. 1C to 1E, as the position of the cartridge receiving portion 170 is adjusted from a Down position to an Up position, the light arrow indicates the force applied by the springs 194 and the dark arrow or O next to the right of the sliding mechanism 180 indicates the resultant force on the carrier structure 160. As shown by the arrows next to the springs 194 in FIG. 1E, the springs 194 exert forces in two directions. Because the stopper 198 may be positioned in the first opening 186, the stopper 198 may limit how far the cartridge receiving portion 170 may be moved bi-directionally between the Up and Down positions.

[0079] The springs 194 may be configured to form a bistable device so that the springs may be loaded in both the Up and Down positions. In other words, the springs 194 may be configured to provide a resistive force that resists moving the cartridge receiving portion 170 towards the Middle position. For example, as shown in FIG. 1E, when the cartridge receiving portion is at the Middle position, the springs 194 may mainly exert a horizontal force. At the Lower Intermediate and Upper Intermediate positions, the forces exerted by the springs 194 may have vertical components. The springs 194 may be configured so a threshold force or greater must be applied to the cartridge receiving

portion 170 using the button structure in order to move the cartridge receiving portion 170 toward and past the Middle position from either the Up or Down positions. Otherwise, the cartridge receiving portion 170 will revert back to the original Up or Down position if less than the threshold force is applied to the cartridge receiving portion 170. Thus, the position of the cartridge receiving portion 170 is biased towards the Up or Down positions.

[0080] In further detail, referring to FIGS. 1D and 1E, if the cartridge receiving portion 170 is at or near the Down position, or at or near the Up position, then the springs 194 may be configured to provide a resistive force that resists moving the cartridge receiving portion 170 towards the Middle position. The springs 194 may be configured so a threshold force or greater must be applied to the cartridge receiving portion 170 using the button structure in order to move the cartridge receiving portion 170 from the Down position through the Lower Intermediate position and past the Middle position. Otherwise, the cartridge receiving portion 170 will revert back to the Down position if less than the threshold force is applied to the cartridge receiving portion 170. Similarly, the springs 194 may be configured so a threshold force or greater must be applied to the cartridge receiving portion 170 using the button structure in order to move the cartridge receiving portion 170 from the Up position through the Upper Intermediate position and past the Middle position. From the Middle position, the springs 194 will undergo a decompression when the cartridge receiving portion 170 is moved towards the Up or Down positions. Thus, the Middle position serves as a tipping point from which the cartridge receiving portion 170 is urged towards the Up or Down positions.

[0081] FIG. 1F is a perspective view of an electronic vaping device according to an example embodiment.

[0082] Referring to FIG. 1F, the electronic vaping device 1001 in FIG. 1F may be the same as the electronic vaping device 1000 described in FIGS. 1A to 1D, except the e-vaping case of the electronic vaping device in FIG. 1F may further include an activation button 135. The activation button 135 may be attached to the housing. For example, the activation button 135 may be arranged on an outer surface of the front cover 120. The activation button 135 may be electrically connected to the electronics system 200. The electronics system 200 may be configured to transfer power to the electrical contact structure 245 using the power supply 230 if the cartridge receiving portion 170 is moved to at least a first position P1 of the housing and the activation button 135 is pressed at the same time.

[0083] The electronics system 200 may be configured to interrupt the transfer of power to the electrical contact structure if activation button 135 is released and/or the cartridge receiving portion 170 is moved towards the second surface 115 of the housing. The electronics system 200 may be configured to terminate the transfer of power to the electrical contact structure 245 using the power supply 230 if the activation button 135 is pressed longer than a threshold amount of time (e.g., more than 10 seconds). For example, the controller 220 may be configured to track how long the activation button 135 is pressed down and the controller 220 may prevent the power supply 230 from supplying power to the electrical contact structure 245 if activation button 135 is pressed down for longer than the threshold amount of time without being released.

[0084] FIG. 1G is a perspective view of an electronic vaping device according to an example embodiment.

[0085] Referring to FIG. 1G, the electronic vaping device 1002 in FIG. 1G may be the same as the electronic vaping device 1000 described in FIGS. 1A to 1F, except the e-vaping case of the electronic vaping device in FIG. 1G may further include a lid 140 attached to the first surface 110 of the front cover 120 and/or rear cover 125 of the housing. The lid 140 may be secured to the housing by a hinge H. The hinge H may be connected to the first surface 110 of the housing. The hinge H may be formed of a metal or a metal alloy. The lid 140 may be formed of the same material as the front cover 120 and/or rear cover 125. When the cartridge 300 protrudes through the opening O, the lid 140 may be opened. The cartridge 300 may be recessed into the e-vaping case 100 and may be surrounded by the e-vaping case 100 if the cartridge receiving portion 170 is moved along the guide structure towards (e.g., the first plate 182, tracks 190, and second plate 184) the second surface 115 of the e-vaping case 100. The lid 140 may be configured to cover the opening O, cartridge receiving portion 170, and the cartridge 300 if the cartridge receiving portion 170 is recessed into the housing towards the second surface 115 of the housing. For example, when the cartridge 300 is lowered into the housing, the lid 140 may cover the opening O. Also, the lid 140 may cover the opening O even if the cartridge 300 is not inserted in the e-vaping case 100.

[0086] FIG. 1H is a sectional view of a cartridge in the electronic vaping device in FIGS. 1A, 1F, and/or 1G.

[0087] In an example embodiment, the cartridge 300 may include a mouth portion 360, a body 355 that defines one or more air holes 385, a reservoir 375 in the body for holding a pre-vaporization formulation, a vaporizer configured to generate a vapor from the pre-vaporization formulation, and electrical leads 380 connected to the vaporizer in the body 355. The cartridge 300 may be configured to protrude at least partially out of the e-vaping case if the cartridge receiving portion 170 is moved towards the first surface 110 of the housing, for example to the first position P1. The air hole(s) 385 defined by the body of the cartridge 300 may be exposed if the cartridge 300 is on the cartridge receiving portion 170 and the cartridge receiving portion 170 is moved to the first position P1. A puff sensor may be omitted from the cartridge 300.

[0088] A channel 370 may be defined by an inner housing (e.g., a tube or tubular structure) and may be inside the body 355. The channel 370 may be adjacent to the reservoir 375. A top of the channel 370 may extend through the mouth portion 360. The channel 370 may be in fluid communication with the air hole(s) 385 and extend from the body 355 through the mouth portion 360 to an end of the cartridge 300.

[0089] The cartridge 300 may be configured to be recessed into the e-vaping case and to be surrounded by the e-vaping case if the cartridge receiving portion 170 is moved along the guide structure towards the second surface 115 of the e-vaping case. In the example shown in FIG. 1G, the lid 140 may be configured to cover the opening O and the cartridge 300 if the cartridge receiving portion 170 is recessed into the housing towards the second surface 115 of the housing. The body 355 and the mouth portion 360 may be each formed of a plastic material, wood, and/or paper, but is not limited to these materials. The body 355 and the mouth portion 360 may be formed of the same material, different materials, or some common materials and some different materials.

[0090] The pre-vapor formulation may include nicotine, water, and a vapor former (e.g., glycerin and/or propylene glycol), but is not limited thereto. For example, the pre-vapor formulation may further include an acid and/or flavoring additive. The flavoring additive may include one of menthol, limonene, benzaldehyde, ethyl vanoline, and combinations thereof.

[0091] The acid may be one of pyruvic acid, formic acid, oxalic acid, glycolic acid, acetic acid, isovaleric acid, valeric acid, propionic acid, octanoic acid, lactic acid, levulinic acid, sorbic acid, malic acid, tartaric acid, succinic acid, citric acid, benzoic acid, oleic acid, aconitic acid, butyric acid, cinnamic acid, decanoic acid, 3,7-dimethyl-6-octenoic acid, 1-glutamic acid, heptanoic acid, hexanoic acid, 3-hexenoic acid, trans-2-hexenoic acid, isobutyric acid, lauric acid, 2-methylbutyric acid, 2-methylvaleric acid, myristic acid, nonanoic acid, palmitic acid, 4-pentenoic acid, phenylacetic acid, 3-phenylpropionic acid, hydrochloric acid, phosphoric acid, sulfuric acid, and combinations thereof. The acid also may be incorporated in the pre-vapor formulation in the form of a salt.

[0092] The vaporizer may include a wick 390 and a heater 395. The heater 395 may surround the wick 390 in the channel 370. For example, the heater 395 may wrap around the wick 390. Respective ends of the heater 395 may be connected to the electrical leads 380. The wick 390 may extend from the reservoir 375 to the channel 370. For example, the wick 390 may extend from one portion of the reservoir 375 through the channel 370 into another portion of the reservoir 375.

[0093] The heater 395 may be in the form of a wire coil, a planar body, a ceramic body, a single wire, a cage of resistive wire or any other suitable form. The heater 395 may be wrapped around a part of the wick 390 such as a part of the wick 390 in the channel 370. If the heater 395 generates a vapor from a first portion of the pre-vapor formulation, the wick 390 (or a plurality of wicks) may transport a second portion of the pre-vapor formulation proximate to the heater 395 to replenish the first portion of the pre-vapor formulation formed into the vapor. The vapor may be transported to a top of the mouth portion 360 if a negative pressure is applied to the mouth portion 360.

[0094] The wick 390 may be constructed of a fibrous and flexible material. The wick 390 may include at least one filament that is configured to transport pre-vapor formulation from the reservoir 375 to the heater 395 when negative pressure is applied to the mouth portion 360.

[0095] The vaporizer may be configured to generate a vapor from heating a portion of the pre-vapor formulation. Power may be supplied to the heater 395 from the power supply 230 (see FIG. 1B) using the electrical contact structure 245 and the electrical leads 380. The power supplied to the heater 395 may generate a vapor from heating the portion of pre-vapor formulation transported to the heater 395 using the wick 390.

[0096] Referring to FIG. 1H, the cartridge 300 may include a body 355 and a mouth portion 360. A first surface (e.g., front surface) of the cartridge 300 may include a window 365. The body 355 may include air holes 385. The body 355 may have a curved outer periphery (e.g., oval or circular) and the body 355 may be elongated. In the example shown in FIG. 1H, the air holes 385 are defined on a second surface (e.g., back surface) of the body 355 that is opposite

the surface of the body including the window 365, but example embodiments are not limited thereto.

[0097] The cartridge receiving portion 170 may include an electrical contact structure 245 for connecting the electrical leads 380 in the cartridge 300 to the electronics system 200 in the e-vaping case. The electrical leads 380 may be formed of a conductive material such as a metal or a metal alloy.

[0098] The cartridge 300 may be configured to be detachably coupled to the cartridge receiving portion 170. For example, the cartridge 300 may connect to a surface of the cartridge receiving portion 170 and the electrical contact structure 245 like a phone jack, DC jack, or USB plug, etc. For example, a bottom surface 315 of the cartridge may define a cartridge opening CO and the cartridge 300 may be placed on the cartridge receiving portion 170 so the electrical contact structure 245 extends into the cartridge opening CO and connects to the electrical leads 380. Alternatively, although not illustrated, if the electrical contact structure 245 is alternatively a female electrical connector, then a bottom of the cartridge 300 may include a male electrical connector that may be electrically connected to the electrical leads 380 and may be coupled to the electrical contact structure 245. The electronics system 200 (see FIG. 1B) may be configured to generate vapor from the pre-vaporization formulation by transferring power to the vaporizer of the cartridge through the electrical contact structure 245 and electrical leads 380 if the cartridge receiving portion 170 is moved towards the first surface 110 of the housing to at least the first position P1 of the housing (see FIGS. 1B and 1D).

[0099] The electrical leads 380 may be configured to electrically connect the vaporizer to the electrical contact structure 245 of the e-vaping case. The e-vaping case being configured to initiate the generating the vapor by transferring power to the vaporizer of the cartridge using the electrical leads 380. For example, the e-vaping case 100 may be configured to initiate generating the vapor from the pre-vaporization formulation if the cartridge 300 is moved to a first location relative to the e-vaping case. The e-vaping case 100 may be configured to interrupt the generating the vapor if the cartridge 300 is moved toward a second location relative to an end of the e-vaping case. The first location of the cartridge 300 relative to an end of the e-vaping case and the second location of the cartridge 300 relative to an end of the e-vaping case may be different.

[0100] Because the electronics system 200 may be configured to initiate a transfer of power to the electrical contact structure 245 if the cartridge 300 is coupled to the cartridge receiving portion 170 and moved towards the first surface 110 of the housing to at least a first position of the housing, the first location of the cartridge 300 relative to the e-vaping case may correspond a location of the cartridge 300 when the cartridge 300 is coupled to the cartridge receiving portion 170 and the cartridge receiving portion 170 is moved to the first surface 110 of the housing to at least a first position of the housing. Because the electronics system 200 may be configured to interrupt the transfer of power to the electrical contact structure 245 if the cartridge receiving portion 170 is moved toward the second surface 115 of the housing to a second position of the housing, the second location of the cartridge 300 relative to the e-vaping case may correspond to a location of the cartridge 300 when the cartridge 300 is coupled to the cartridge receiving portion 170 and the cartridge receiving portion 170 is moved to the second surface 115 of the housing.

[0101] FIGS. 2A and 2B are transparent views of an electronic vaping device according to an example embodiment. FIG. 2C is an exploded view of the electronic vaping device in FIGS. 2A and 2B.

[0102] Referring to FIGS. 2A to 2C, in an example embodiment, an electronic vaping device 2000 may include an e-vaping case 101 and a cartridge 400. The e-vaping case 101 may include a housing, a guide structure 181 that extends between a first surface 110 (or top surface) of the housing and a second surface 115 (or bottom surface) of the housing, a cartridge receiving portion 148 connected to the guide structure 181, and an electronics system in the housing. The housing may define an opening O' at the first surface 110 of the housing and an opening O'' at the second surface 115 of the housing. The housing of the e-vaping case 101 may be formed by joining a front cover to a rear cover, similar to the housing of the e-vaping case 100.

[0103] The electronic vaping device 1001 may be formed by inserting the cartridge 400 into the opening O' of the e-vaping case 101. The cartridge 400 may include a body portion. The body portion may include a window 465 that is transparent and/or translucent. As a result, contents inside the body portion (e.g., a level a pre-vapor formulation inside the cartridge 400) may be viewable through window 465. A button protruding portion 146 may be exposed through an aperture A defined by the front of the housing. More details related to the cartridge 400 are described later with reference to FIG. 2D. The guide structure may be a guide plate 181. The guide plate 181 may be formed of a metal, metal alloy, a plastic, a fibrous material (e.g., wood), a ceramic, or a combination thereof. A puff-sensor may be omitted from the e-vaping case 101 and/or the cartridge 400.

[0104] The electronics system 200 in the e-vaping case 101 of the electronic vaping device 2000 may be the same as or similar to the electronics system 200 described with reference to FIGS. 1A to 1G.

[0105] The e-vaping case may include a button structure including the button protruding portion 146 and a button wall portion 151. First to fourth bump structures 255, 260, 265, and 270 may be spaced apart from each other in a vertical direction inside of the housing. The first to fourth bump structures 255, 260, 265, and 270 may be formed of the same material as the housing or a different material. The housing, for example the intermediate portion 105, may be formed of a metal, metal alloy, a plastic, a fibrous material (e.g., wood), a ceramic, or a combination thereof. The first to fourth bump structures 255, 260, 265, and 270 may be connected to an inner surface of the housing, such as an interior of the housing that faces the button wall portion 151. Alternatively, at least one of the first to fourth bump structures 255, 260, 265, and 270 may be defined by a protruding portion of the inner surface of the housing.

[0106] As shown in FIG. 2C, the aperture A may be defined by an intermediate portion 105 of the housing. The aperture A may be between the first surface 110 of the housing and the second surface 115 of the housing. The aperture A may include a first border (e.g., top border) adjacent to the first surface 110 of the housing and a second border (e.g., bottom border) adjacent to the second surface 115 of the housing. The aperture A may include third and fourth borders (e.g., left and right borders) that connect the first and second borders to each other. The cartridge receiving portion 148 may be configured to be moved between the first and second surfaces 110 and 115 of the housing by

adjusting a position of the button protruding portion 146 in the aperture A such that moving the button protruding portion 146 towards the first surface 110 of the housing corresponds to moving the cartridge receiving portion 148 towards the first surface 110 of the housing and moving the button protruding portion 146 towards the second surface 115 of the housing corresponds to moving the cartridge receiving portion 148 towards the second surface 115 of the housing. The first and second borders of the aperture A may limit a distance that the button protruding portion 146 may be adjusted in the aperture A.

[0107] The cartridge receiving portion 148 may include an electrical contact structure 245. The electrical contact structure 245 may be formed of a conductive material such as a metal or a metal alloy. The electrical contact structure 245 may be electrically connected to the electronics system 200. The cartridge receiving portion 148 may be configured to reversibly snap in place if the cartridge receiving portion 148 is moved to the first position P1. The electronics system 200 may be configured to initiate the transfer of power to the electrical contact structure 245 using the power supply 230 if the cartridge receiving portion 148 is snapped in place at the first position P1. The cartridge receiving portion 148 may be configured to be un-snapped and moved along the guide structure 181 toward the second surface 115 of the housing after being reversibly snapped in place. The electronics system 200 may be configured to interrupt the transfer of power to the electrical contact structure 245 if the cartridge receiving portion 148 is un-snapped.

[0108] The e-vaping case 101 may include a button structure and connecting members 191 in the housing. The button structure may include the button protruding portion 146, pegs 147, and the button wall portion 151. The pegs 147 may extend from a surface of the button protruding portion 146. A front face of the button wall portion 151 may define female connecting members 134. The pegs 147 may be inserted into the female connecting members 134 to form a snap-fit connection that connects the button protruding portion 146 to the button wall portion 151.

[0109] The guide structure 181 may be in the housing. The connecting members 191 may pass around sides of the guide structure 181 and connect the cartridge receiving portion 148 to the button structure. A surface of the button wall portion 151 that is opposite the female connecting members 134 may define other female connecting members 133 at a different height the female connecting members 134. A surface of the cartridge receiving portion 148 may define female connecting members 131 adjacent to the electrical contact structure 245. Opposite ends of the connecting members 191 may be inserted into corresponding female connecting members 133, respectively, and may form snap-fit connections to connect the cartridge receiving portion 148 to the button wall portion 151.

[0110] When the intermediate portion 105 of the housing encloses the button structure connected to the cartridge receiving portion 148, the button protruding portion 146 may extend into the aperture A and face an outside of the housing. The cartridge receiving portion 148 may be configured to be moved between the first surface 110 and the second surface 115 of the housing by adjusting a position of the button protruding portion 146 in the aperture A. Moving the button protruding portion 146 towards the first surface 110 of the housing may move the cartridge receiving portion

148 towards the first surface **110** of the housing. Moving the button protruding portion **146** towards the second surface **115** of the housing may correspond to moving the cartridge receiving portion **148** towards the second surface **115** of the housing.

[0111] The switch sensor **240** may be in the housing. The cartridge receiving portion **148** may include a level member **148L**. The level member **148L** may be a portion of the cartridge receiving portion **148** that extends from a side of the cartridge receiving portion **148**. The level member **148L** may be between the switch sensor **240** and the second surface **115** of the housing. A height the level member **148L** may be between an upper surface and a lower surface of the cartridge receiving portion. The cartridge receiving portion **148** may include two vertical members **148V** that are spaced apart from each other and each have a width that is less than a width of the cartridge receiving portion **148**. The two vertical members **148V** may define a cartridge accommodating area and the electrical contact structure **245** may be disposed in the cartridge accommodating area. The two vertical members **148V** may be spaced apart from each other by a distance that is greater than a width of the cartridge **400** and less than entire width of the cartridge receiving portion **148**. In other words, the two vertical members **148V** may be spaced apart from each other so the cartridge **400** may be inserted between the two vertical members **148V** and placed on the electrical contact structure **245**. For example, the cartridge **400** may connect to a surface of the cartridge receiving portion **148** and the electrical contact structure **245** like a phone jack, DC jack, or USB plug, etc.

[0112] The level member **148L** may be configured to contact the switch sensor **240** if the cartridge receiving portion **148** is moved to the first position **P1** in the housing. For example, a bottom of the cartridge receiving portion **148** may define a hooked portion **148H** that extends toward the second surface **115** of the housing. As shown in FIG. 2B, the first position **P1** of the housing may be between the third and fourth bump structures **265** and **270**. The first position **P1** may correspond to a location of the cartridge receiving portion **148** when the hooked portion **148H** is disposed between the third and fourth bump structures **265** and **270**. The switch sensor **240** may be configured to depress momentarily if the cartridge receiving portion **148** is moved past the first position **P1** to a second position **P2** in the housing. The second position **P2** in the housing may be closer to the first surface **110** of the housing than the first position **P1** in the housing. For example, the second position **P2** may correspond to a location of the cartridge receiving portion **148** when the hooked portion **148H** is above the fourth bump structure **270**. For example, second position **P2** may correspond to a location when a bottom of the hooked portion **148H** contacts an upper surface of the fourth bump structure **270**.

[0113] The first bump structure **255** and the second bump structure **260** may be adjacent to each other. The third bump structure **265** and the fourth bump structure **270** may be adjacent to each other. The second bump structure **260** and the third bump structure **265** may be between the first bump structure **255** and the fourth bump structure **270**.

[0114] The hooked portion **148H** may be configured to bump over the second bump structure **260** and sit at a zero position **P0** in the housing between the first and second bump structures **255** and **260** as the cartridge receiving portion is moved from the first surface **110** of the housing

towards the second surface **115** of the housing. The hooked portion **148H** may be configured to bump over the third bump structure **265** as the cartridge receiving portion **148** is moved towards the first surface **110** of the housing such that the hooked portion **148H** moves from the zero position **P0** to the first position **P1**.

[0115] The level member **148L** may be configured depress the switch sensor **240** if the cartridge receiving portion **148** is moved towards the first surface **110** of the housing such that the hooked portion **148H** moves from the first position **P1** between the third and fourth bump structures **265** and **270** and bumps over the fourth bump structure **270**.

[0116] When the housing encloses the button structure, the switch sensor **240**, the cartridge receiving portion **148**, and the guide structure **181**, the button protruding portion **146** may extend into the aperture **A** and face an outside of the housing, the button protruding portion is configured to move the level member towards the switch sensor if the button protruding portion is moved towards the first surface of the housing and away from the second surface of the housing. By adjusting the position of the button protruding portion **146** in the aperture **A**, the button protruding portion **146** may be configured to move the level member **148L** away from the switch sensor **240** if the button protruding portion is moved towards the second surface **115** of the housing and away from the first surface **110** of the housing.

[0117] The level member **148L** may be configured to depress the switch sensor **240** if the button protruding portion **146** is moved to a top boundary of the aperture **A** and is within a threshold distance **D1** of the top boundary of the aperture **A**. The electronics system **200** may be configured to transfer power to the electrical contact structure **245** if the level member **148L** depresses the switch sensor **240**. The switch sensor **240** may be configured to snap back down to an original position of the switch sensor **240** after the level member **148L** depresses the switch sensor **240**.

[0118] FIG. 2D is a sectional view of a cartridge in the electronic vaping device in FIGS. 2A to 2B.

[0119] In an example embodiment, the cartridge **400** may include a mouth portion **460**, a body **455** that defines one or more air holes **485**, a reservoir **475** in the body for holding a pre-vaporization formulation, a vaporizer configured to generate a vapor from the pre-vaporization formulation, and electrical leads **480** connected to the vaporizer in the body **455**. The cartridge **400** may be configured to protrude at least partially out of the e-vaping case if the cartridge receiving portion **148** is moved is moved towards the first surface **110** of the housing, for example to the first position **P1**. The air hole(s) **485** defined by the body **455** of the cartridge **400** may be exposed if the cartridge **400** is on the cartridge receiving portion **148** and the cartridge receiving portion **170** is moved to the first position **P1**. A puff sensor may be omitted from the cartridge **400**.

[0120] A channel **470** may be defined by an inner housing (e.g., a tube or tubular structure) and may be inside the body **455**. The channel **470** may be adjacent to the reservoir **475**. A top of the channel **470** may extend through the mouth portion **460**. The channel **470** may be in fluid communication with the air hole(s) **485** and extend from the body **455** through the mouth portion **460** to an end of the cartridge **400**.

[0121] The cartridge **400** may be configured to be recessed into the e-vaping case **101** and to be surrounded by the e-vaping case **101** if the cartridge receiving portion **148** is moved along the guide structure towards the second surface

115 of the e-vaping case **101**. Although illustrated in FIGS. 2A and 2B, similar to FIG. 1G, a lid may be configured to cover the opening **O'** and the cartridge **400** if the cartridge receiving portion **148** is recessed into the housing towards the second surface **115** of the housing. The body **455** and the mouth portion **460** may be each formed of a plastic material, wood, and/or paper, but is not limited to these materials. The body **455** and the mouth portion **460** may be formed of the same material, different materials, or some common materials and some different materials.

[0122] The vaporizer may include a wick **490** and a heater **495**. The heater **495** may surround the wick **490** in the channel **470**. For example, the heater **495** may wrap around the wick **490**. Respective ends of the heater **495** may be connected to the electrical leads **480**. The wick **490** may extend from the reservoir **475** to the channel **470**. For example, the wick **490** may extend from one portion of the reservoir **475** through the channel **470** into another portion of the reservoir **475**.

[0123] The heater **495** and wick **490** may be the same as or similar to heater **395** and wick **390** described with reference to FIG. 1H. If the heater **495** generates a vapor from a first portion of the pre-vapor formulation, the wick **490** (or a plurality of wicks) may transport a second portion of the pre-vapor formulation proximate to the heater **495** to replenish the first portion of the pre-vapor formulation formed into the vapor. The vapor may be transported to a top of the mouth portion **460** if a negative pressure is applied to the mouth portion **460**.

[0124] The vaporizer may be configured to generate a vapor from heating a portion of the pre-vapor formulation. Power may be supplied to the heater **495** from the power supply **230** using the electrical contact structure **245** and the electrical leads **480**. The power supplied to the heater **495** may generate a vapor from heating the portion of pre-vapor formulation transported to the heater **495** using the wick **490**.

[0125] Referring to FIG. 2D, the cartridge **400** may include a body **455** and a mouth portion **460**. A first surface (e.g., front surface) of the cartridge **400** may include a window **465**. The body **455** may have a curved outer periphery (e.g., oval or circular) and the body **455** may be elongated. In the example shown in FIG. 2D, the air holes **485** are defined on a surface of the body that is opposite the surface of the body including the window **465**, but example embodiments are not limited thereto.

[0126] The cartridge receiving portion **148** may include the electrical contact structure **245** for connecting the electrical leads **480** in the cartridge **400** to the electronics system **200** in the e-vaping case. The electrical leads **480** may be formed of a conductive material such as a metal or a metal alloy.

[0127] The cartridge **400** may be configured to be detachably coupled to the cartridge receiving portion **148**. For example, a bottom surface of the cartridge **400** may define a cartridge opening **CO** and the cartridge **400** may be placed on the cartridge receiving portion **148** so the electrical contact structure **245** extends into the cartridge opening **CO** and connects to the electrical leads **480**. Although not illustrated, if the electrical contact structure **245** is alternatively a female electrical connector, then a bottom of the cartridge **400** may include a male electrical connector that may be electrically connected to the electrical leads **480** and may be coupled to the electrical contact structure **245**. The

electronics system **200** may be configured to generate vapor from the pre-vaporization formulation by transferring power to the vaporizer of the cartridge **400** through the electrical contact structure **245** and electrical leads **480** if the cartridge receiving portion **148** is moved towards the first surface **110** of the housing to at least the first position **P1** of the housing.

[0128] The electrical leads **480** may be configured to electrically connect the vaporizer to the electrical contact structure **245** of the e-vaping case **101**. The e-vaping case may be configured to initiate the generating the vapor by transferring power to the vaporizer of the cartridge **400** using the electrical leads **480**. For example, the e-vaping case **101** may be configured to initiate generating the vapor from the pre-vaporization formulation if the cartridge **400** is moved to a first location relative to the e-vaping case. The e-vaping case **101** may be configured to interrupt the generating the vapor if the cartridge **300** is moved toward a second location relative to an end of the e-vaping case. The first location of the cartridge **400** relative to an end of the e-vaping case and the second location of the cartridge **400** relative to an end of the e-vaping case may be different.

[0129] The first location of the cartridge **400** relative to the e-vaping case **101** may correspond to a location of the cartridge **400** when the cartridge **400** is coupled to the cartridge receiving portion **148** and the cartridge receiving portion **148** is moved to the first surface **110** such that the level member **148L** depresses the switch sensor **240**. The second location of the cartridge **400** relative to the e-vaping case **101** may correspond to a location of the cartridge **400** when the cartridge **400** is coupled to the cartridge receiving portion **148** and does not depress the switch sensor **240**. For example the second location of the cartridge **400** may correspond to a location of the cartridge **400** the hooked portion **148H** is between the fourth bump structure **270** and the first bump structure **255**.

[0130] FIGS. 3A to 3C is a perspective view, plan view, and a sectional view of an electronic vaping device according to an example embodiment. FIG. 3D is an exploded view of the electronic vaping device in FIGS. 3A to 3C.

[0131] Referring to FIGS. 3A to 3D, in an example embodiment, an electronic vaping device **3000** may be similar to the electronic vaping devices **1000**, **1001**, and **1002** described with reference to FIGS. 1A, 1E, and/or 1G. The electronic vaping device **3000** may include an e-vaping case **102** and the cartridge **300**.

[0132] The e-vaping case **100** may include a housing, a guide structure that extends between the first surface **110** and second surface **115** of the housing, a cartridge receiving portion **170** connected to the guide structure, and an electronics system **200** in the housing. The cartridge receiving portion **170** may be configured to be moved along the guide structure between the first surface **110** and the second surface **115** of the housing. The guide structure may include two guide portions **184'** that are spaced apart from each other in the housing. The electronics system may be configured to initiate a transfer of power to the electrical contact structure **245** if the cartridge receiving portion **170** is moved towards the first surface **110** of the housing to at least a first position of the housing. The electronics system **200** may be configured to interrupt the transfer of power to the electrical contact structure **245** if the cartridge receiving portion **170** is moved towards the second surface **115** of the housing.

[0133] The housing may include an intermediate portion **105** between the first surface **110** and the second surface **115**.

The intermediate portion **105** may be formed by connecting the front cover **120** to the rear cover **125** of the housing. The electronics system **200** may be connected to a display screen **107** (e.g., a liquid-crystal display or a light emitting device display) for displaying information about the electronic vaping device **3000**, such as the battery charge level, vapor precursor level, puff count, and various operation error messages transmitted to the display screen **107** from the controller **220**, but example embodiments are not limited thereto.

[0134] The e-vaping case **102** may include a sliding mechanism **180'** in the housing. The housing may define a cavity **C**. The cavity **C** may be the inner portion of the housing surrounded by the intermediate portion **105** when the front cover **120** and rear cover **125** are connected to each other. The electronics system **200** may be in the cavity. A sidewall of the housing may define the guide structure in the form of the pair of guide portions **184'**. The sliding mechanism **180'** may include a first plate **182** and tracks **190** attached to respective sides of the first plate **182**. The tracks **190** may connect the first plate **182** to the guide portions **184'**. The cartridge receiving portion **170** may be connected to the first plate **182**. The cartridge receiving portion **170** may be configured to be moved bi-directionally between the first and second surfaces **110** and **115**, respectively, of the housing via the tracks **190**. For example, the tracks **190** may slide along the guide portions **184'**. The carrier structure **160** may be in the housing. The carrier structures **160** may include the carrier plate **165** and the cartridge receiving portion **170**. The carrier plate **165** may connect the cartridge receiving portion **170** to the first plate **182** of the sliding mechanism **180'**. Magnets **M** may be attached to the carrier plate **165** at or near the upper and lower surfaces of the carrier plate **165**. Magnets **M** may be attached to inner surfaces of the rear cover **125** near the first and second surfaces **110** and **115** of the housing. One or more stoppers **198** may be attached to an inner surface of the rear cover **125**. The stoppers **198** may extend into the first and/or second openings **186** and **188**, respectively, of the first plate **182** in order to limit how far the first plate **182** is moved bi-directionally between the first and second surfaces **110** and **115**. Together, a part of the housing (e.g., the rear cover **125**) where the stoppers **198** are attached and the guide portions **184'** may also be referred to as a guide member. The stoppers **198** may include a first stopper and a second stopper that are spaced apart in a staggered manner. The first and second stopper may be configured to limit a distance the first plate **182** moves bi-directionally.

[0135] The e-vaping case **102** may include the button structure **B**. The button structure **B** may be connected to the carrier plate **165**. The cartridge receiving portion **170** may be configured to be moved between the first and second surfaces **110** and **115** of the housing by adjusting a position of the button protruding portion **145** in the aperture **A** such that moving the button protruding portion **145** towards the first surface **110** of the housing corresponds to moving the cartridge receiving portion **170** towards the first surface **110** of the housing and moving the button protruding portion **145** towards the second surface **115** of the housing corresponds to moving the cartridge receiving portion **170** towards the second surface **115** of the housing.

[0136] The electronic vaping device **3000** may be formed by placing the cartridge **300** on the cartridge receiving portion **148**. The cartridge **300** may be detachably coupled

to the cartridge receiving portion **148** and electrically connected to the electrical contact structure **245**. The electrical contact structure **245** may be part of the electronics system **200** in the e-vaping case **102**.

[0137] FIG. 4 is a front view of an electronic vaping device according to an example embodiment.

[0138] Referring to FIG. 4, in an example embodiment, an electronic vaping device **4000** may be similar to the electronic vaping devices **1000**, **1001**, **1002**, **2000**, and **3000** described with reference to FIGS. 1A to 1G, FIGS. 2A to 2D, and 3A to 3D.

[0139] The electronic vaping device **4000** may include an e-vaping case **103** and the cartridge **300**. The electronic vaping device **4000** may be formed by attaching the cartridge **300** to a cartridge receiving portion in the e-vaping case **103**, for example through an opening defined by the first surface **110** of the housing. An electronics system may be in the case and may include the electrical contact structure. The electronics system may be the same as or similar to the electronics system **200** of the e-vaping cases **100**, **101**, and **102** described above.

[0140] The e-vaping case **103** may include a housing, a guide structure that extends between the first surface **110** and the second surface **115** of the housing, a cartridge receiving portion connected to the guide plate **118**, and an electronics system in the housing. The cartridge receiving portion may be configured to be moved along the guide plate **118** between the first surface **110** and the second surface **115** of the housing. The guide plate **118** may define a path for moving a button structure **B'** bi-directionally between the first surface **110** and the second surface **115** of the housing. The electronics system may be configured to initiate a transfer of power to an electrical contact structure if the cartridge receiving portion is moved towards the first surface **110** of the housing to at least a first position of the housing. The electronics system may be configured to interrupt the transfer of power to the electrical contact structure if the cartridge receiving portion is moved towards the second surface **115** of the housing.

[0141] The electronics system **200** may be connected to a display screen **108** (e.g., a liquid-crystal display or a light emitting device display) for displaying information about the electronic vaping device **4000**, such as the battery charge level, vapor precursor level, puff count, and various operation error messages transmitted to the display screen **108** from the controller in the electronics system, but example embodiments are not limited thereto.

[0142] The button structure **B'** may be connected to the cartridge receiving portion and the housing may enclose the cartridge receiving portion. The button structure **B'** may include a button protruding portion that may extend through the path defined by the guide plate **118** and face an outside of the e-vaping case **103**. Inside of the e-vaping case **103**, the button structure **B'** may be connected to a carrier structure and a sliding mechanism that are the same as or similar to the carrier structure **160** and sliding mechanism **180** described with reference to FIGS. 1B and 1C. In this regard, because the button structure **B'** may be connected to the carrier structure and the sliding mechanism. The cartridge receiving portion may be configured to be moved between the first and second surfaces **110** and **115** of the housing by adjusting a position of the button protruding portion of the button structure **B'**. For example, moving the button protruding portion of the button structure **B'** towards the first

surface **110** of the housing may correspond to moving the cartridge receiving portion towards the first surface **110** of the housing and moving the button protruding portion of the button structure **B'** towards the second surface **115** of the housing corresponds to moving the cartridge receiving portion towards the second surface of the housing.

[0143] Alternatively, inside of the e-vaping case **103**, the button structure **B'** may be connected to a carrier structure and a sliding mechanism that are the same as or similar to the carrier structure **160** and sliding mechanism **180'** described with reference to FIG. 3D. The sliding mechanism inside the e-vaping case **103** may be attached to a pair of guide portions using tracks, like to the connection arrangement between the sliding mechanism **180'** and guide portions **184'** in the e-vaping case **102** described with reference to FIGS. 3A to 3D.

[0144] The electronic vaping device **3000** is not limited to the cartridge **300**. In an alternative embodiment, the shape of the opening defined by the housing of the e-vaping case **103** may be modified to accommodate the cartridge **400** described with reference to FIGS. 2A and 2D. The button structure **B'** of the e-vaping case **103** may be connected to a cartridge receiving portion and a guide structure using an arrangement that is the same as or similar to the connection of the button structure (e.g., button protruding portion **146**, pegs **147**, button wall portion **151**) to the guide structure **181** and the cartridge receiving portion **148** in FIGS. 2A to 2D. Additionally, like the e-vaping case **101** in FIGS. 2A to 2C, the housing of the e-vaping case **103** may include bump structures like the bump structures **255**, **260**, **265**, and **270** in the e-vaping case **103**. Consequently, in the e-vaping case **103** according to the alternative embodiment, as cartridge receiving portion is moved bi-directionally between the first and second surfaces **110** and **115** of the housing, a hooked portion of the cartridge receiving portion may bump over and/or contact the bump structures.

[0145] FIGS. 5A to 5C are a perspective view, a plan view, and a sectional view of an electronic vaping device according to an example embodiment.

[0146] Referring to FIGS. 5A to 5C, the electronic vaping device **5000** may include an e-vaping case **104** and a cartridge **500**. The cartridge **500** may be detachably coupled to the e-vaping case **104**. The e-vaping case **104** may include a housing **106**, a guide structure **127** that extends between a first surface **110** of the housing and a second surface **115** of the housing, a cartridge receiving portion **171** connected to the guide structure **127**, and an electronics system **200**. The cartridge receiving portion **171** may be configured to be moved bi-directionally using the guide structure **127**. The electronics system **200** may include a power supply **230** that is configured to initiate a transfer of power to an electrical contact structure **245** if the cartridge receiving portion **171** is moved towards the first surface of the housing to at least a first position of the housing. The electronics system **200** may be configured to interrupt the transfer of power to the electrical contact structure **245** if the cartridge receiving portion **171** is moved towards the second surface **115** of the housing. The electronics system **200** may include an external device connection structure **235** for connecting to an external device (e.g., power charger, computer, etc.).

[0147] Referring to FIG. 5A, a bottom surface of the cartridge receiving portion **171** may be adjusted to a first position of the housing such that the bottom surface of the cartridge receiving portion **171** is above the second surface

115 of the housing **106**. The bottom surface of the cartridge receiving portion **171** may be moved towards the second surface **115** of the housing **106** such that the second surface **115** of the housing may be about level with the bottom surface of the cartridge receiving portion **171**.

[0148] The cartridge receiving portion **171** may be attached to a back surface of the housing **106** and may be configured to be moved along the guide structure **127** in a vertical direction from behind the housing **106**. The guide structure **127** may be rails. Protruding portions **106P** of the housing **106** may be used to connect the housing to the guide structure **127**. The guide structure **127** may be connected to the cartridge receiving portion **171**.

[0149] The cartridge receiving portion **171** may include a frame **172**. The cartridge receiving portion **171** may include a window **166**. The window **166** may be transparent and may allow viewing a level of pre-vapor formulation in a reservoir in the cartridge **500**. A button **135** may be attached to an outer surface of the housing. The screen **107** may be attached to the housing **106**. The screen **107** may be connected to the electronics system **200**. The button **135** may be connected to the electronics system **200**. Alternatively, the button **135** may be omitted. A puff sensor may be omitted from the e-vaping case **104**.

[0150] An air hole of the cartridge may be exposed if the cartridge **500** is coupled to the cartridge receiving portion **171** and the cartridge receiving portion is moved to the first position. The cartridge **500** may include a mouth piece **560**. A back surface of the housing **106** may cover the mouth piece **560** if the cartridge **500** is coupled to the cartridge receiving portion **171** and the cartridge receiving portion **171** is moved to a second position along the guide structure. A puff sensor may be omitted from the cartridge **500**.

[0151] The electronics system **200** may include a driving circuit **210**, a controller **220**, a power supply **230**, an external device connection structure **235**, an electrical contact **246**, a wire **W**, and a sensor **S1**. The cartridge receiving portion **171** may include a sensor **S2** and the electrical contact structure **245**. Although not illustrated, wires may connect the controller **220** to the power supply and may connect the power supply **230** to the electrical contact **246**. If the cartridge receiving portion **171** is moved towards the first surface of the housing **106** to at least a first position of the housing **106**, then the sensor **S1** of the electronics system **200** may be about the same height as the sensor **S2** and may contact the sensor **S2**. Additionally, the electrical contact **246** may be about the same height as the electrical contact structure **245** and may contact the electrical contact structure **245**. Using the sensor **S1**, the controller **220** may detect the sensors **S1** and **S2** at about the same height and may direct the power supply **230** to provide power to the cartridge **500** through the electrical contact **246** and the electrical contact structure **245**. The electronics system **200** may be configured to interrupt the transfer of power to the electrical contact structure **245** if the cartridge receiving portion **171** is moved towards the second surface **115** of the housing.

[0152] The cartridge **500** may include a vaporizer, a channel, and a reservoir. The reservoir may be used to store pre-vapor formulation. The electronics system **200** may be configured to automatically transfer the power to the vaporizer in the cartridge **500** if the cartridge receiving portion is moved to the first position of the housing **106**. Alternatively, the electronics system **200** may be configured to automatically transfer the power to the vaporizer in the cartridge **500**

if the button **135** connected to the electronics system **200** is pressed when the cartridge receiving portion **171** is at the first position of the housing **106**.

[0153] FIG. 6A is a perspective view of an electronic vaping device according to an example embodiment. FIG. 6B is an exploded view of the electronic vaping device in FIG. 6A.

[0154] Referring to FIGS. 6A and 6B, the electronic vaping device **6000** may be the same as (or substantially the same as) the electronic vaping device **1000** described with respect to FIG. 1A except for the dimensions of the e-vaping case **100'**. As shown in FIG. 6A, the e-vaping case **100'** may have a width X2 that is less than its thickness Y2. The height Z2 of the e-vaping case **100'** may be greater than its thickness Y2. Additionally, the widths of the button structure B, carrier structure **160**, and sliding mechanism **180** may be adjusted in order to fit inside the housing (e.g., front cover **120** connected to the rear cover **125**). The screen **107** may be attached to the front cover **120** at a location below the aperture A, but is not limited thereto and may alternatively be attached to a side surface of the front cover **120** or rear cover **125**. Although not illustrated, the e-vaping case **100'** may further include the button **135** and/or lid **140** and hinge H from the e-vaping cases in the e-vaping device **1001** and **1002** described above with reference to FIGS. 1F and 1G. Similarly, the electronic vaping devices **2000**, **3000**, **4000**, and **5000** described above may be modified so their respective widths are less than their thicknesses.

[0155] FIG. 7 is a flow chart illustrating a method of making an electronic vaping device according to an example embodiment.

[0156] According to an example embodiment, a method of making an electronic vaping device including a case and a cartridge is provided. The method may include forming the case and coupling a cartridge to the case.

[0157] Referring to FIG. 7, forming the case may include arranging a guide structure between a first surface of a housing and a second surface of the housing (Operation S710), connecting a cartridge receiving portion to the guide structure (Operation S720, and arranging an electronics system in the housing (Operation S730). The cartridge receiving portion may be configured to be moved along the guide structure between the first surface and the second surface of the housing. The electronics system may include a power supply that is configured to initiate a transfer of power to an electrical contact structure if the cartridge receiving portion is moved towards the first surface of the housing to at least a first position of the housing. The electronics system may be configured to interrupt the transfer of power to the electrical contact structure if the cartridge receiving portion is moved towards the second surface of the housing. Forming the electronic vaping device may further include coupling a cartridge to the cartridge receiving portion of the e-vaping case (Operation S740).

[0158] Using the cartridges **300**, **400**, and **500** described above, a vapor may be generated by heating the pre-vapor formulation in the cartridges. As the pre-vapor formulation is consumed, the cartridges **300**, **400**, and/or **500** may either be replaced with new cartridges or refilled with additional pre-vapor formulation.

[0159] In the electronic vaping devices **1000**, **2000**, **3000**, **4000**, **5000**, and **6000** described above, a puff sensor may be omitted. Instead of generating vapor in response to the puff sensor detecting the application of a negative pressure to the

cartridge, the electronic vaping devices **1000**, **2000**, **3000**, **4000**, **5000**, and **6000** include electronics systems that are configured to transfer power to corresponding cartridges or terminate the transfer of power to the corresponding cartridges based on at least a position of the cartridge relative to the housing.

[0160] Example embodiments having thus been described, it will be obvious that the same may be varied in many ways. Such variations are not to be regarded as a departure from the intended spirit and scope of example embodiments, and all such modifications as would be obvious to one skilled in the art are intended to be included within the scope of the following claims.

What is claimed is:

1. An e-vaping case comprising:
 - a housing;
 - a guide structure that extends between a first surface of the housing and a second surface of the housing;
 - a cartridge receiving portion connected to the guide structure, the cartridge receiving portion configured to be moved along the guide structure between the first surface and the second surface of the housing; and
 - an electronics system in the housing, the electronics system including a switch sensor and a power supply that is configured to initiate a transfer of power to an electrical contact structure in response to the cartridge receiving portion being moved towards the first surface of the housing to at least a first position of the housing, the electronics system being configured to interrupt the transfer of power to the electrical contact structure in response to the cartridge receiving portion being moved towards the second surface of the housing.
2. The e-vaping case of claim 1, wherein
 - the guide structure is a sliding mechanism in the housing, the housing defines a cavity,
 - the electronics system is in the cavity,
 - the sliding mechanism includes a first plate, tracks, and a second plate in the housing,
 - the tracks connect the first plate to the second plate,
 - the cartridge receiving portion is connected to the first plate, and
 - the cartridge receiving portion is configured to move bi-directionally between the first and second surfaces of the housing via the tracks.
3. The e-vaping case of claim 2, further comprising:
 - springs connected to the first plate and the second plate.
4. The e-vaping case of claim 1, wherein the e-vaping case does not include a puff sensor.
5. The e-vaping case of claim 1, further comprising:
 - a magnet attached to the cartridge receiving portion.
6. The e-vaping case of claim 1, wherein
 - the guide structure is configured to contact the switch sensor in response to the cartridge receiving portion being moved to the first position in the housing,
 - the switch sensor is configured to snap back to the first position of the housing after being depressed momentarily.
7. The e-vaping case of claim 6, wherein
 - the switch sensor is configured to depress momentarily in response to the cartridge receiving portion being moved past the first position to a second position in the housing.

8. The e-vaping case of claim 7, wherein the switch sensor is configured to snap back to the first position of the housing after being depressed momentarily.

9. The e-vaping case of claim 7, wherein the second position in the housing is closer to the first surface of the housing than the first position in the housing.

10. An electronic vaping device comprising:

a housing;

a guide structure that extends between a first surface of the housing and a second surface of the housing;

a cartridge receiving portion connected to the guide structure, the cartridge receiving portion configured to be moved along the guide structure between the first surface and the second surface of the housing;

an electronics system in the housing, the electronics system including a switch sensor, an electrical contact structure, and a power supply that is configured to initiate a transfer of power to the electrical contact structure in response to the cartridge receiving portion being moved towards the first surface of the housing to at least a first position of the housing, the electronics system being configured to interrupt the transfer of power to the electrical contact structure in response to the cartridge receiving portion being moved towards the second surface of the housing; and

a cartridge on the cartridge receiving portion, the cartridge being configured to be detachably coupled to the cartridge receiving portion and to be electrically connected to the electrical contact structure.

11. The electronic vaping device of claim 10, wherein the guide structure is a sliding mechanism in the housing, the housing defines a cavity, the electronics system is in the cavity, the sliding mechanism includes a first plate, tracks, and a second plate in the housing,

the tracks connect the first plate to the second plate, the cartridge receiving portion is connected to the first plate, and

the cartridge receiving portion is configured to move bi-directionally between the first and second surfaces of the housing via the tracks.

12. The electronic vaping device of claim 11, further comprising:

springs connected to the first plate and the second plate.

13. The electronic vaping device of claim 10, wherein the electronic vaping device does not include a puff sensor.

14. The electronic vaping device of claim 10, further comprising:

a magnet attached to the cartridge receiving portion.

15. The electronic vaping device of claim 10, wherein the guide structure is configured to contact the switch sensor in response to the cartridge receiving portion being moved to the first position in the housing, the switch sensor is configured to snap back to the first position of the housing after being depressed momentarily.

16. The electronic vaping device of claim 15, wherein the switch sensor is configured to depress momentarily in response to the cartridge receiving portion being moved past the first position to a second position in the housing, and

the switch sensor is configured to snap back to the first position of the housing after being depressed momentarily.

17. The electronic vaping device of claim 16, wherein the second position in the housing is closer to the first surface of the housing than the first position in the housing.

18. An e-vaping case comprising:

a housing;

a guide structure that extends between a first surface of the housing and a second surface of the housing;

a cartridge receiving portion connected to the guide structure, the cartridge receiving portion configured to be moved along the guide structure between the first surface and the second surface of the housing;

an electronics system in the housing, the electronics system including a power supply that is configured to initiate a transfer of power to an electrical contact structure in response to the cartridge receiving portion being moved towards the first surface of the housing to at least a first position of the housing, the electronics system being configured to interrupt the transfer of power to the electrical contact structure in response to the cartridge receiving portion being moved towards the second surface of the housing; and

a switch sensor in the housing, wherein

the switch sensor is configured to depress momentarily in response to the cartridge receiving portion being moved past the first position to a second position in the housing,

the second position in the housing is closer to the first surface of the housing than the first position in the housing, and

the switch sensor is configured to snap back to the first position of the housing after being depressed momentarily.

19. The e-vaping case of claim 18, wherein the guide structure is configured to contact the switch sensor in response to the cartridge receiving portion being moved to the first position in the housing.

20. The e-vaping case of claim 18, wherein the guide structure is a sliding mechanism in the housing, the housing defines a cavity, the electronics system is in the cavity, the sliding mechanism includes a first plate, tracks, and a second plate in the housing,

the tracks connect the first plate to the second plate, the cartridge receiving portion is connected to the first plate, and

the cartridge receiving portion is configured to move bi-directionally between the first and second surfaces of the housing via the tracks.

* * * * *