



US 20180322805A1

(19) **United States**

(12) **Patent Application Publication**  
**PETERS et al.**

(10) **Pub. No.: US 2018/0322805 A1**  
(43) **Pub. Date: Nov. 8, 2018**

(54) **SYSTEMS AND METHODS PROVIDING ENHANCED EDUCATION AND TRAINING IN A VIRTUAL REALITY ENVIRONMENT**

No. 8,657,605, which is a continuation-in-part of application No. 12/501,257, filed on Jul. 10, 2009, now Pat. No. 8,747,116.

(71) Applicant: **LINCOLN GLOBAL, INC.**, Santa Fe Springs, CA (US)

(60) Provisional application No. 61/349,029, filed on May 27, 2010, provisional application No. 61/090,794, filed on Aug. 21, 2008.

(72) Inventors: **CARL PETERS**, SOLON, OH (US);  
**DEANNA POSTLETHWAITE**,  
CHAGRIN FALLS, OH (US);  
**MATTHEW WAYNE WALLACE**,  
SOUTH WINDSOR, CT (US)

**Publication Classification**

(51) **Int. Cl.**  
**G09B 19/24** (2006.01)  
**G09B 5/06** (2006.01)  
(52) **U.S. Cl.**  
CPC ..... **G09B 19/24** (2013.01); **G09B 5/06** (2013.01); **B23K 9/0953** (2013.01)

(21) Appl. No.: **16/033,551**

(22) Filed: **Jul. 12, 2018**

**Related U.S. Application Data**

(60) Continuation of application No. 14/248,780, filed on Apr. 9, 2014, which is a division of application No. 13/792,300, filed on Mar. 11, 2013, now Pat. No. 9,280,913, which is a continuation-in-part of application No. 13/081,725, filed on Apr. 7, 2011, now Pat.

(57) **ABSTRACT**

Virtual reality arc welding systems that provide virtual reality simulations for training purposes. Virtual reality welding systems to aid in training welding students may provide a programmable processor-based subsystem, a rendering engine, an analysis engine, and recommended corrective actions based on virtual testing results.

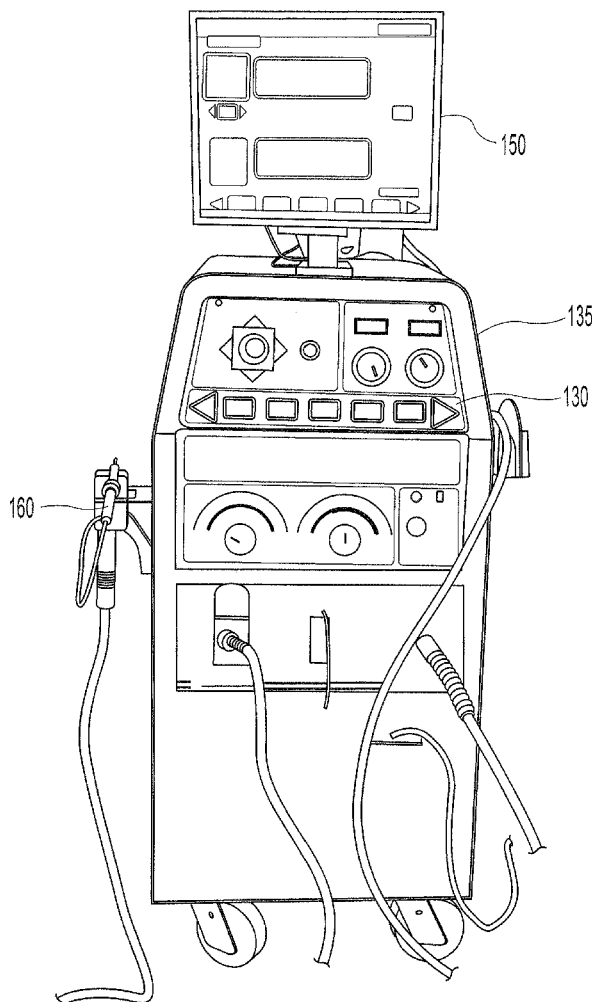

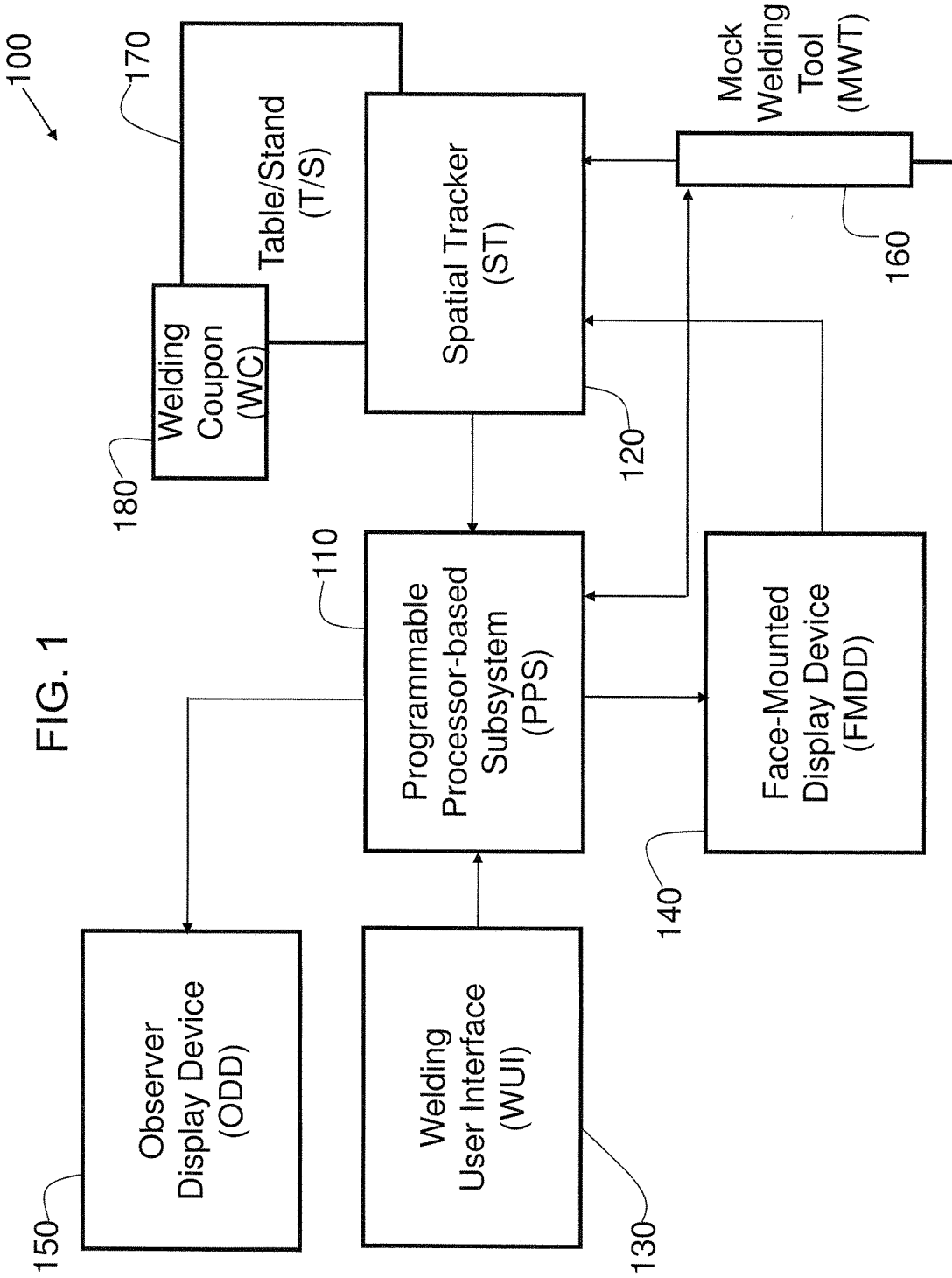

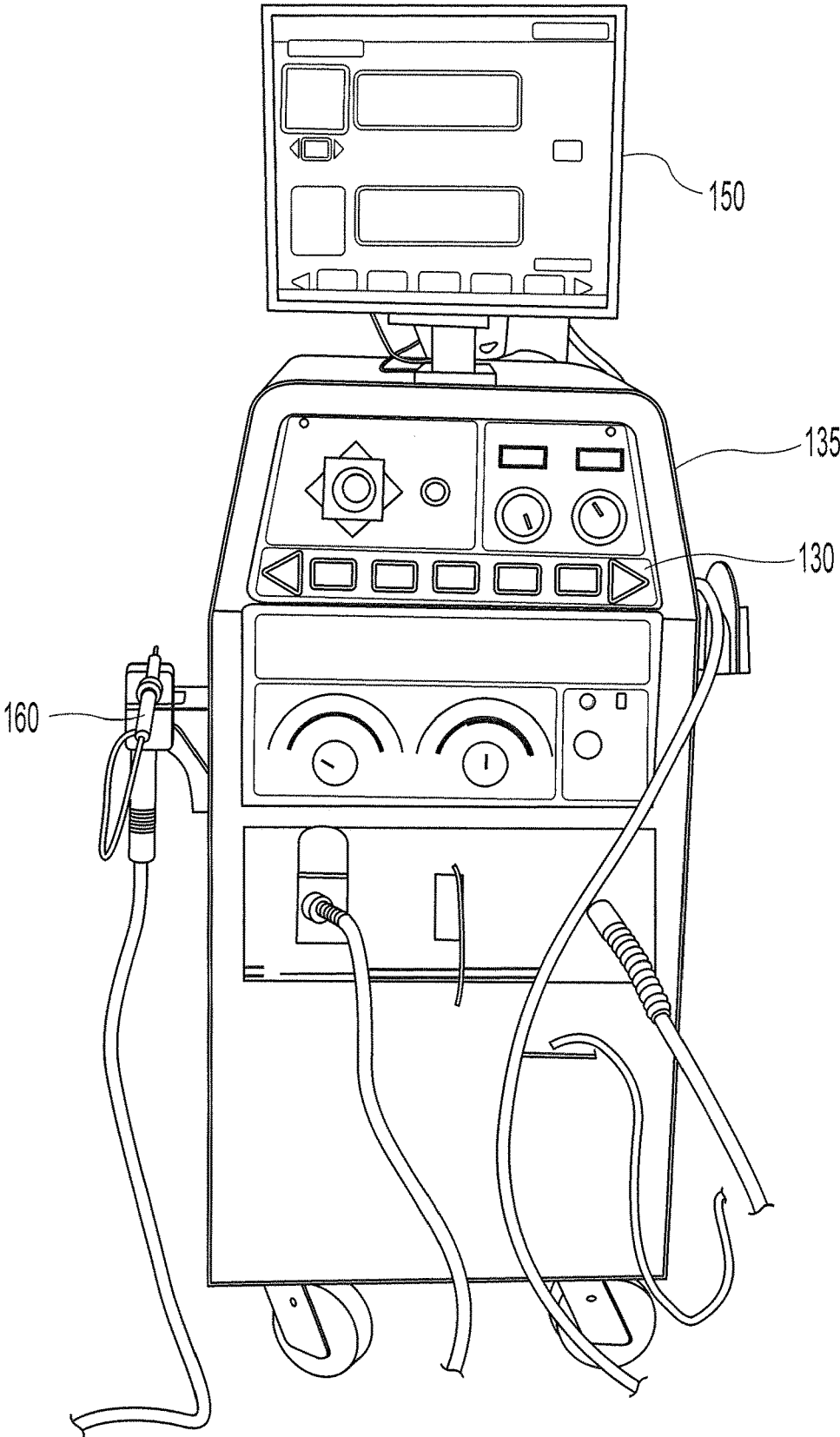

Fig. 2

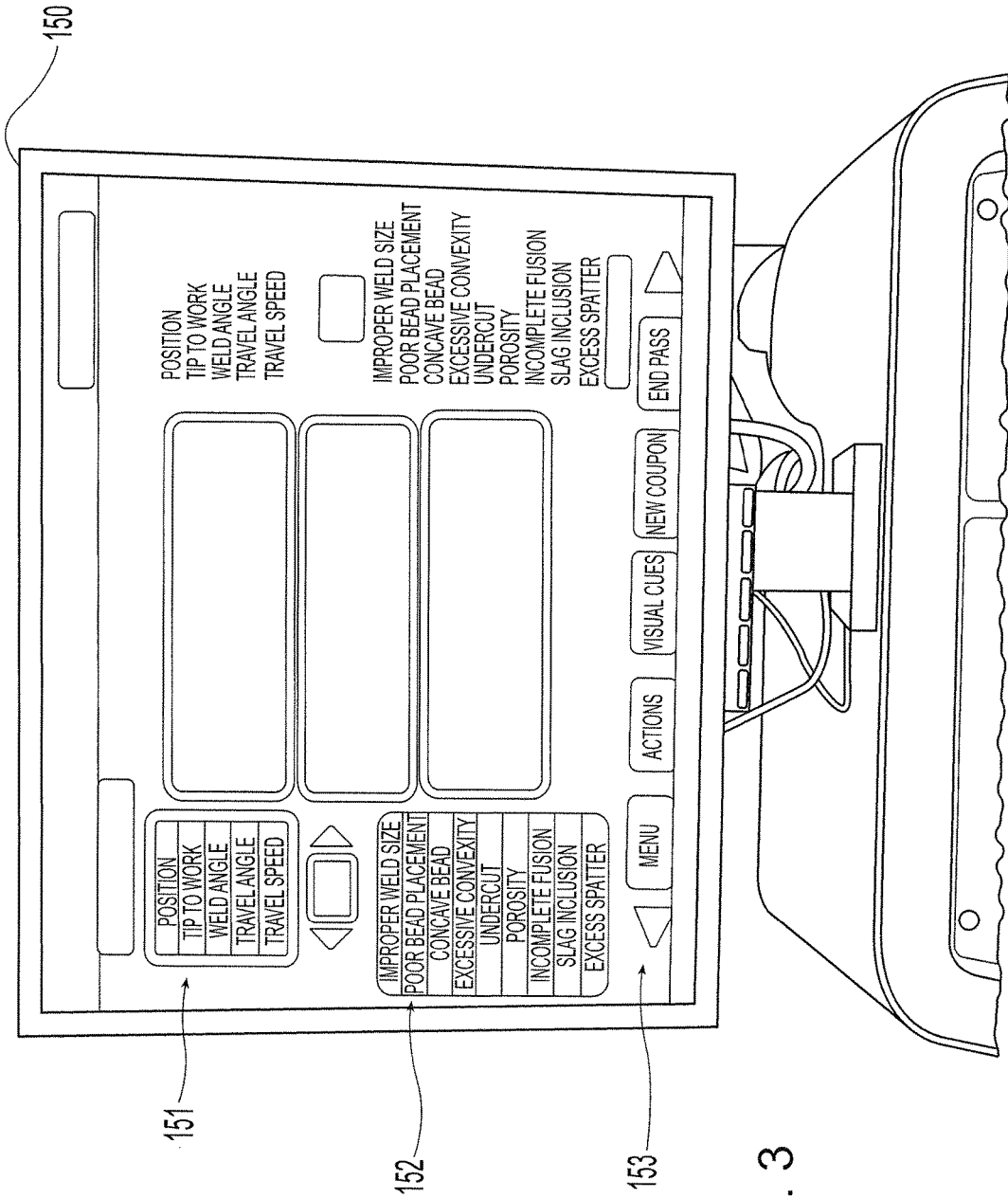

Fig. 3

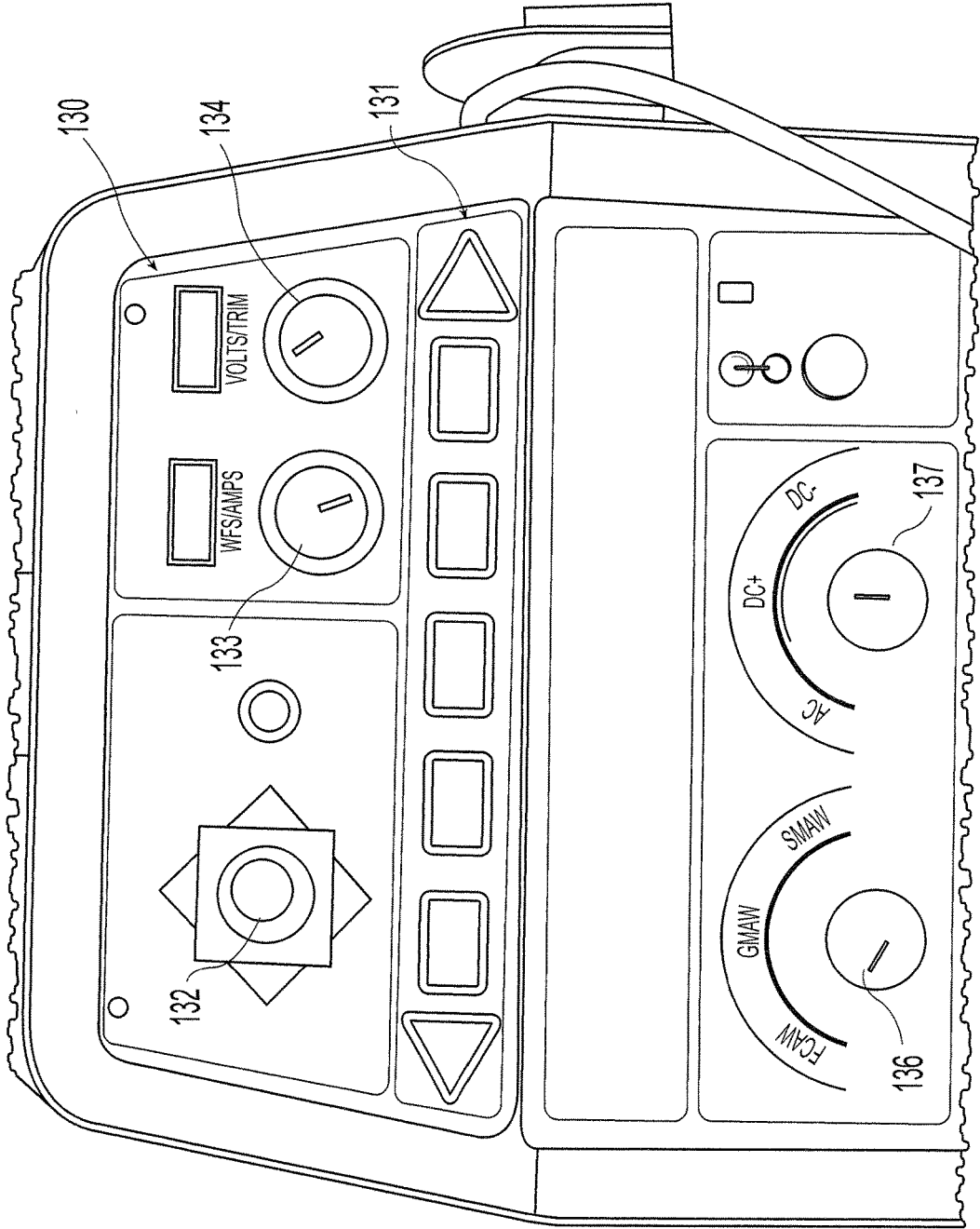

Fig. 4

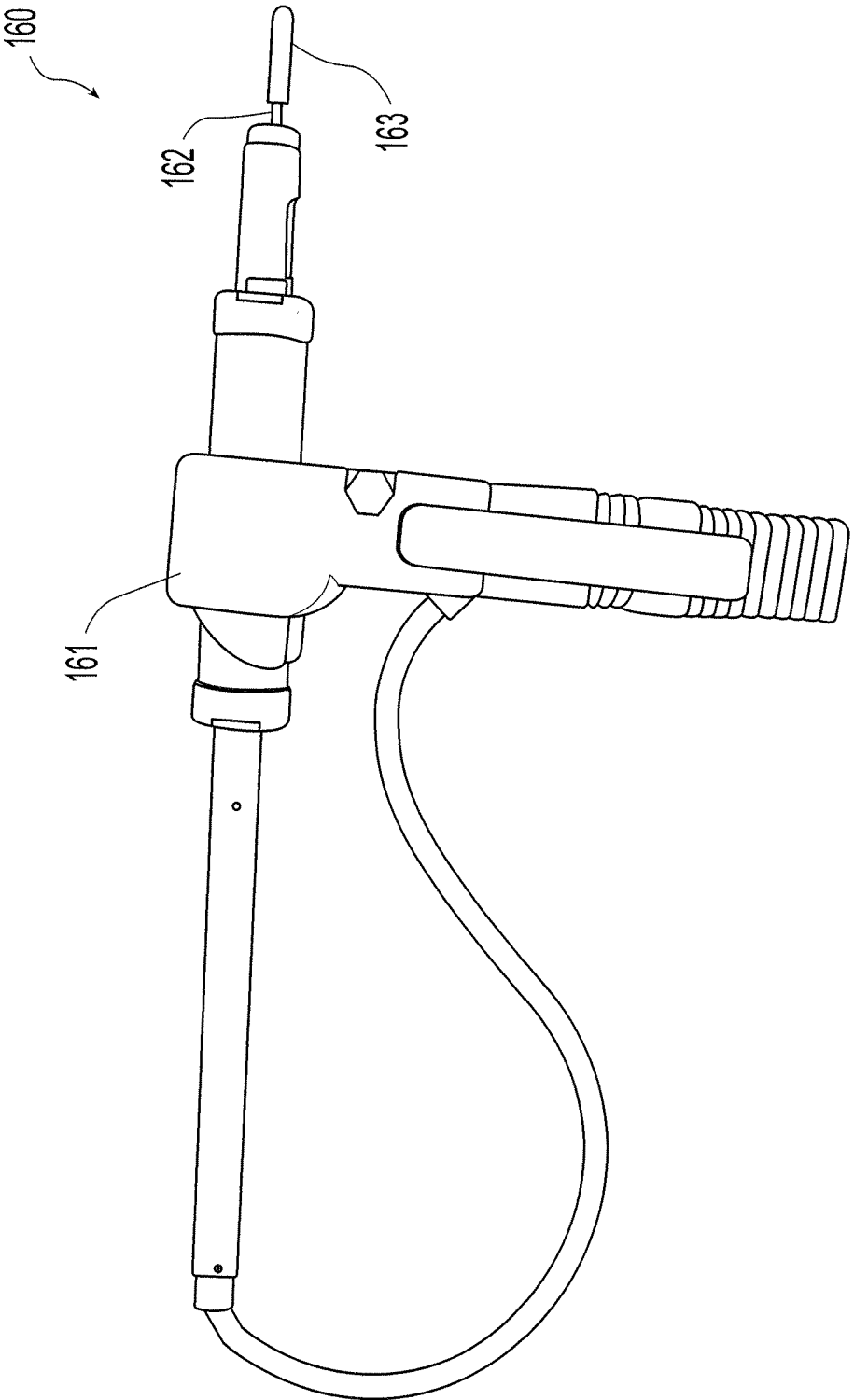

Fig. 5

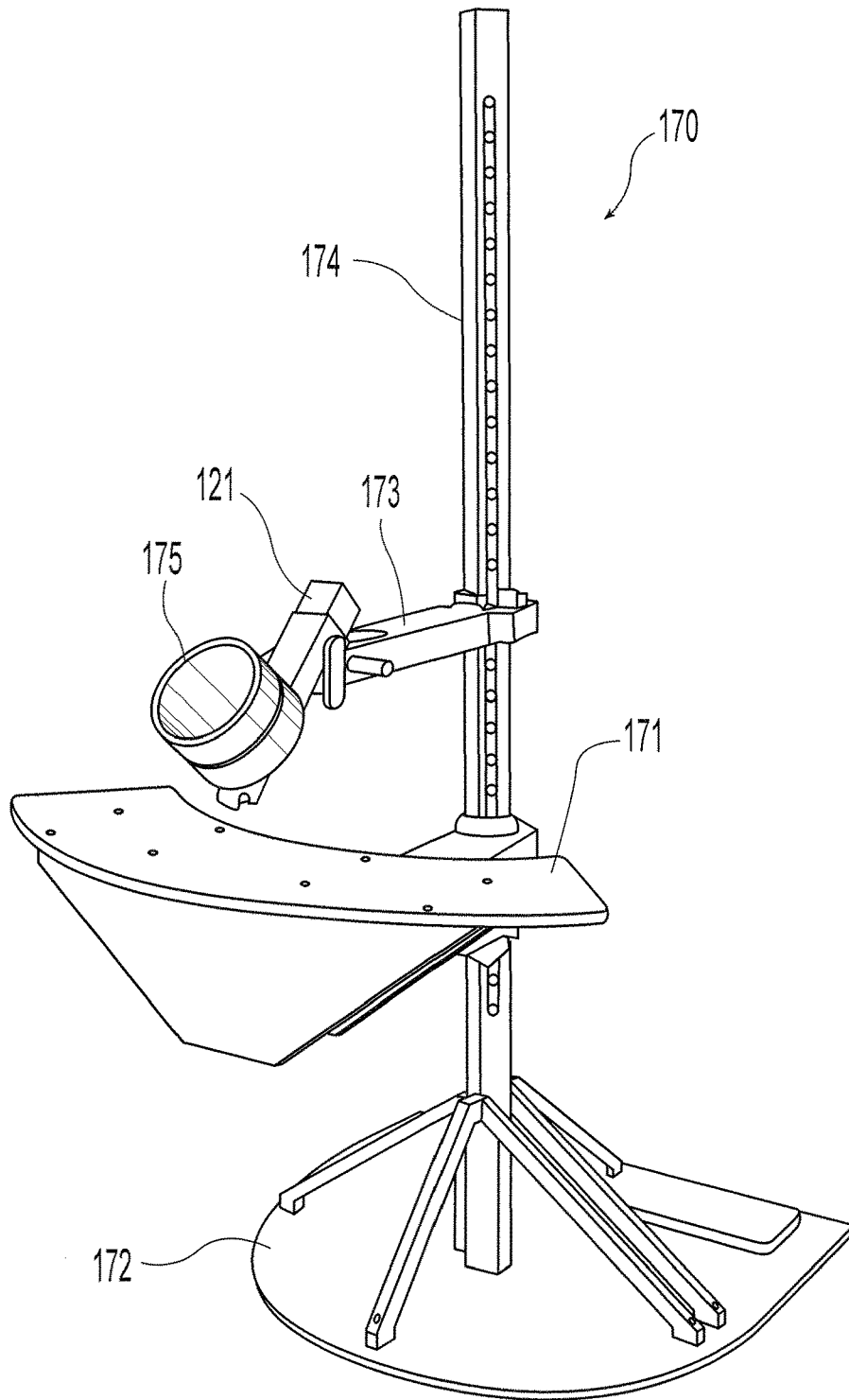

Fig. 6

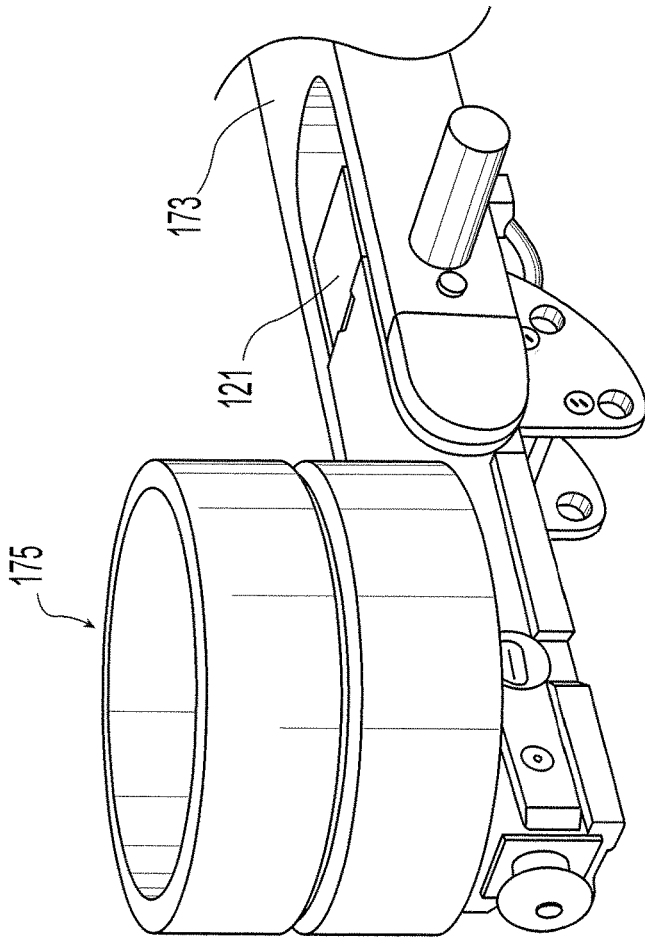

Fig. 7B

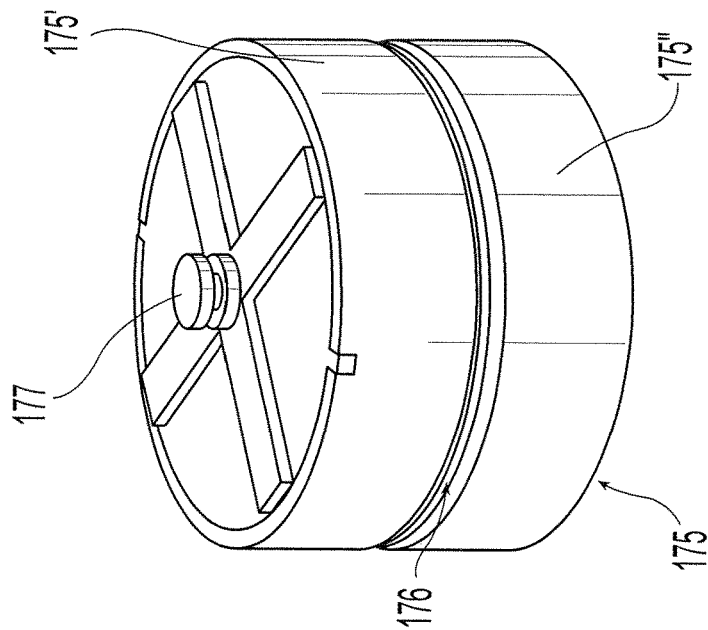

Fig. 7A



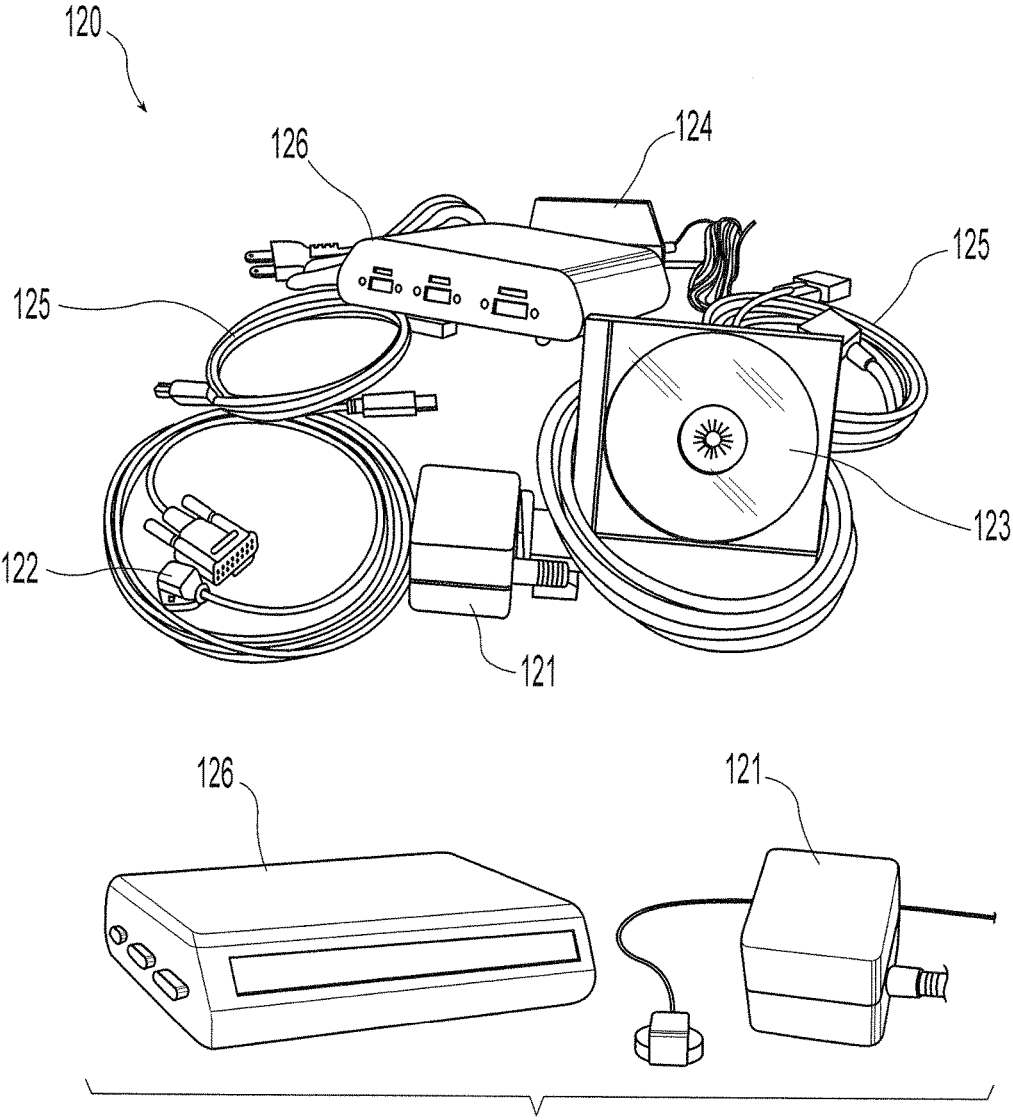

Fig. 8

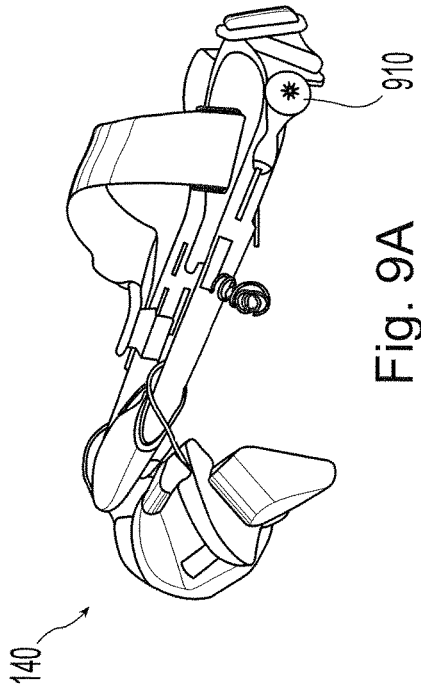

Fig. 9A

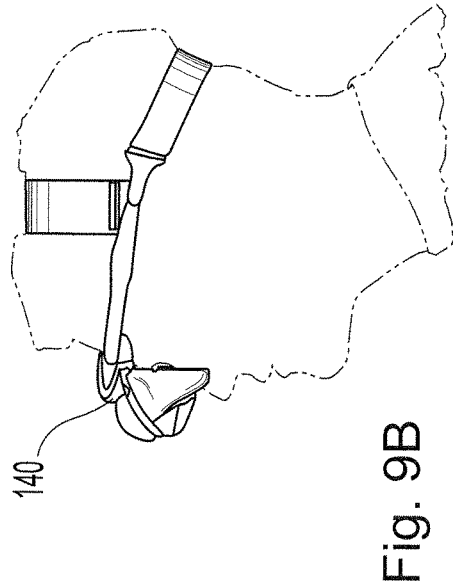

Fig. 9B

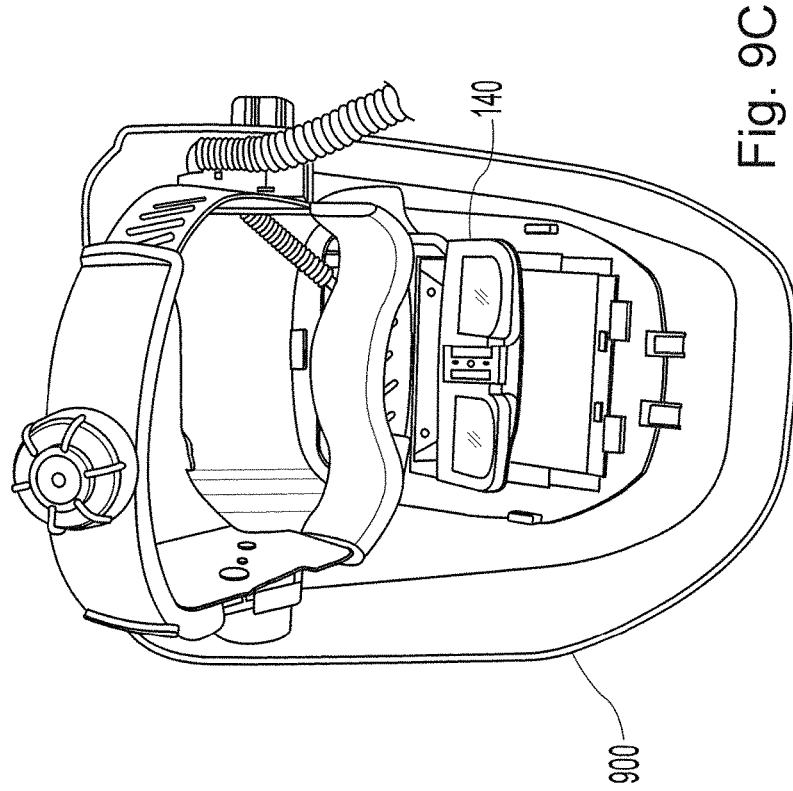

Fig. 9C

FIG. 10

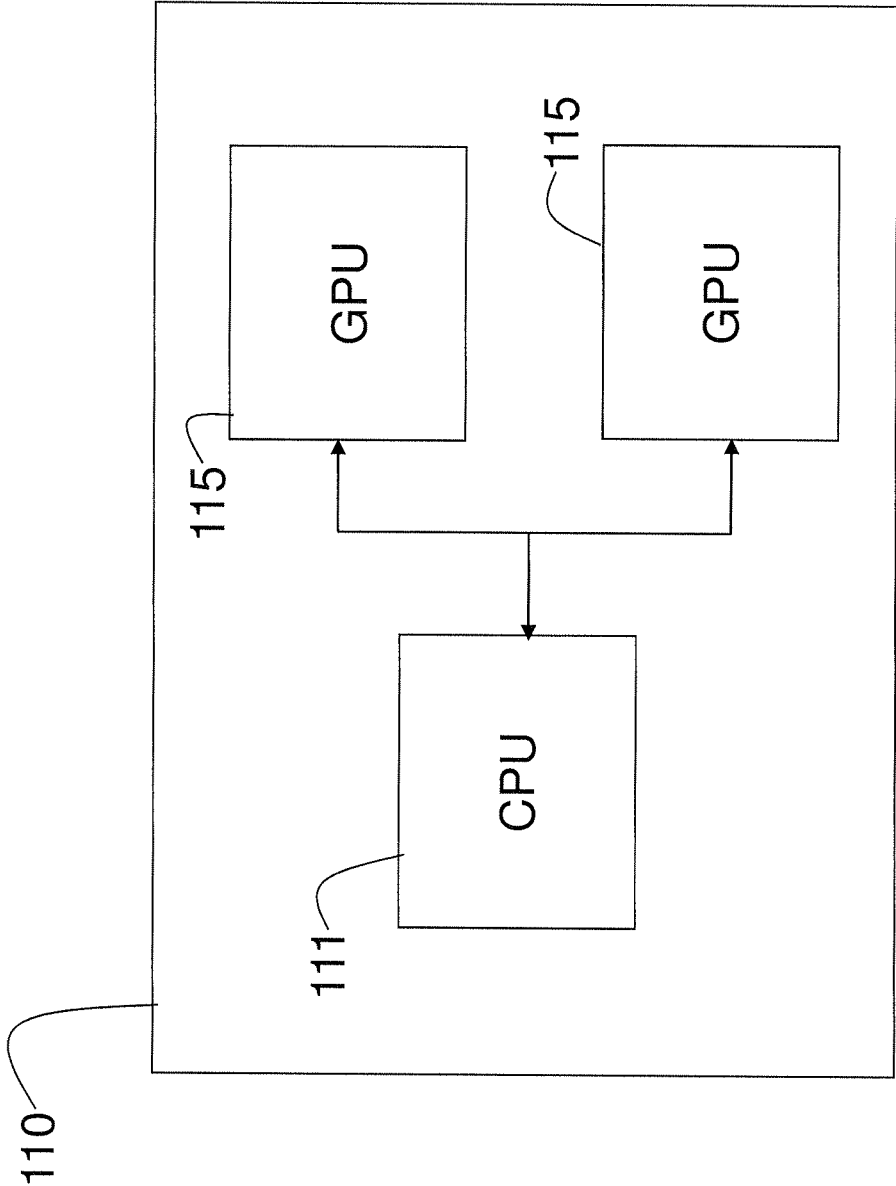
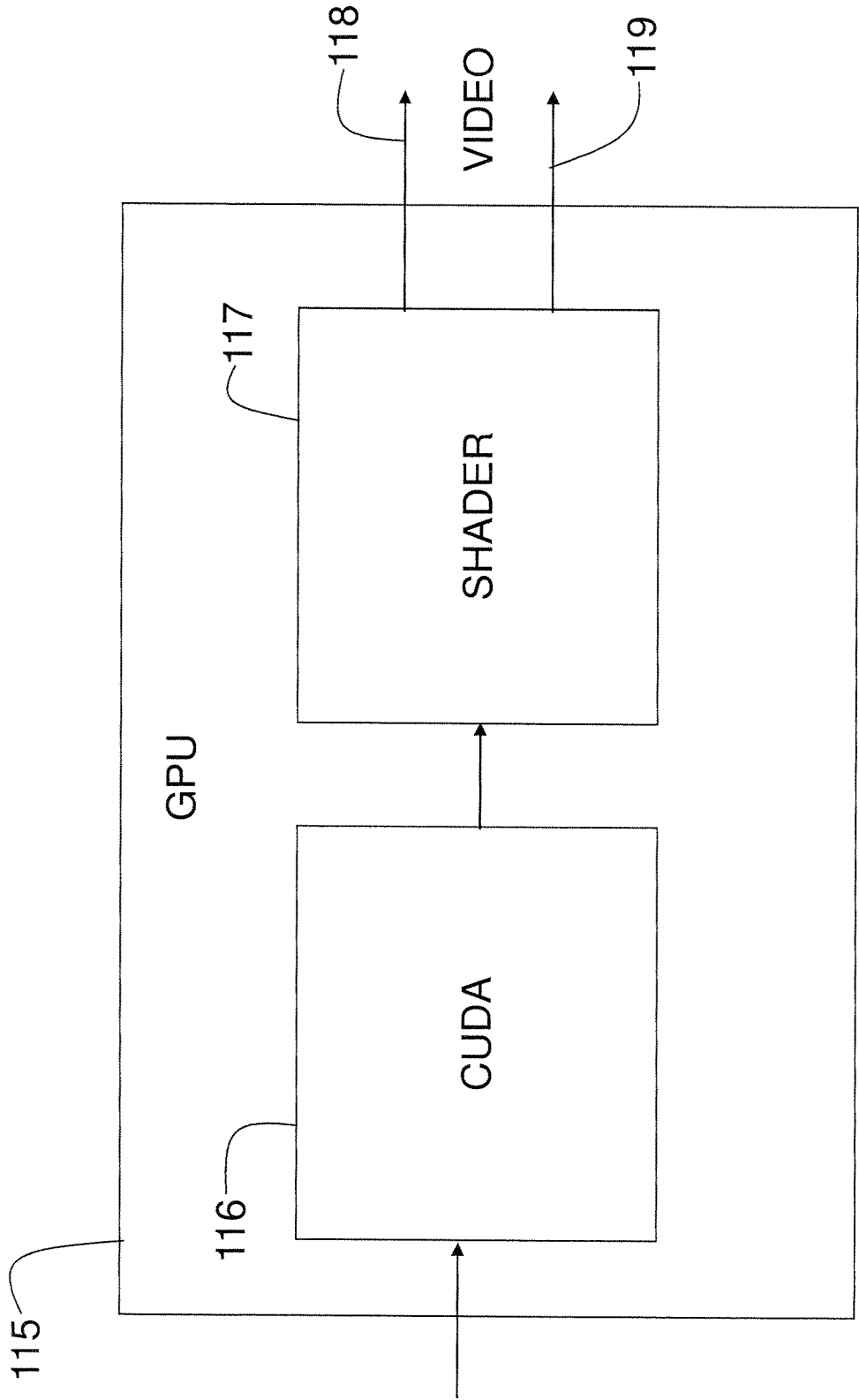

FIG. 11



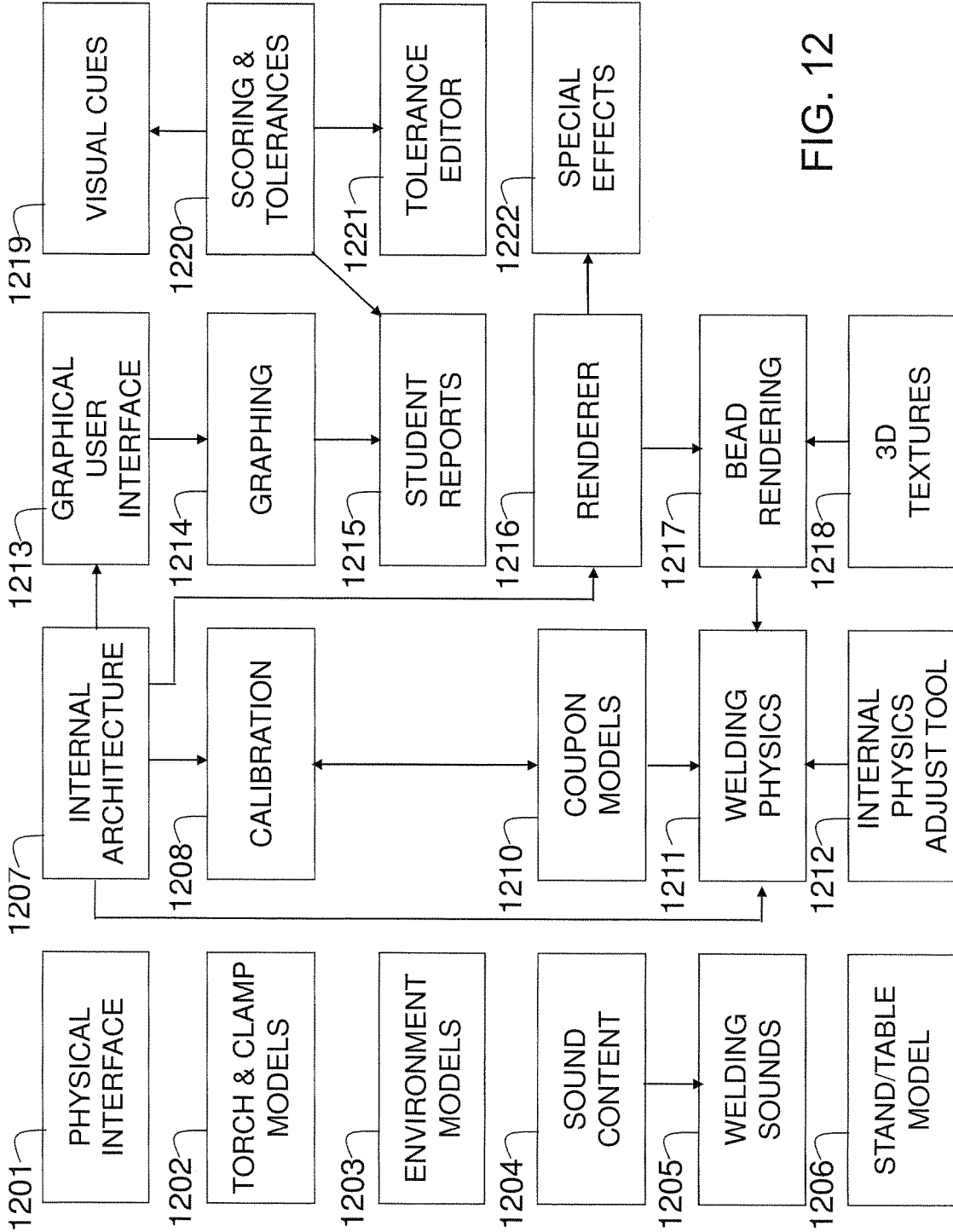

FIG. 12

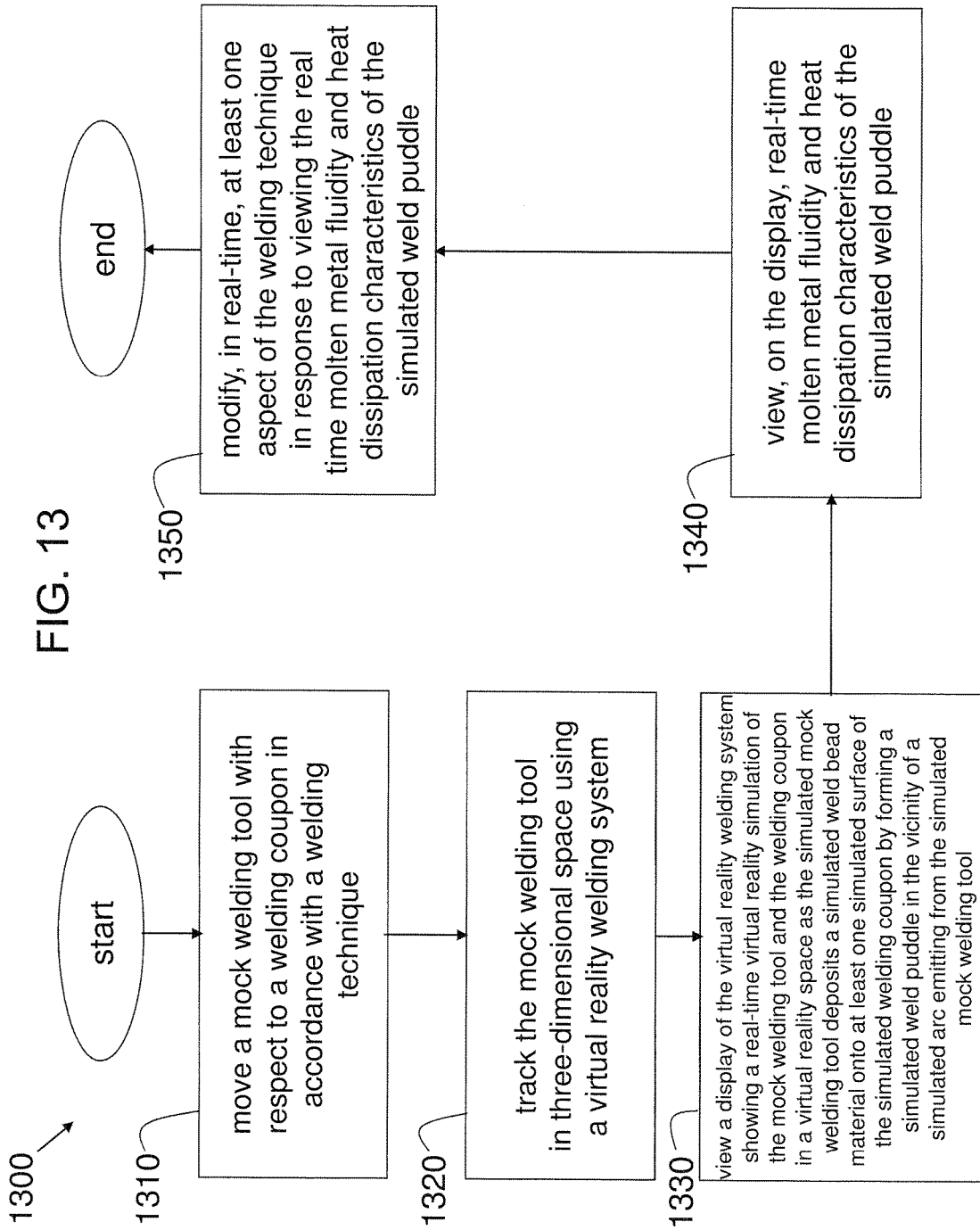

FIG. 13

FIG. 14A

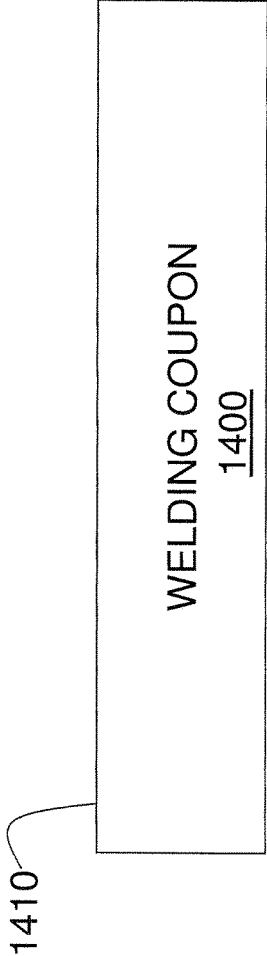
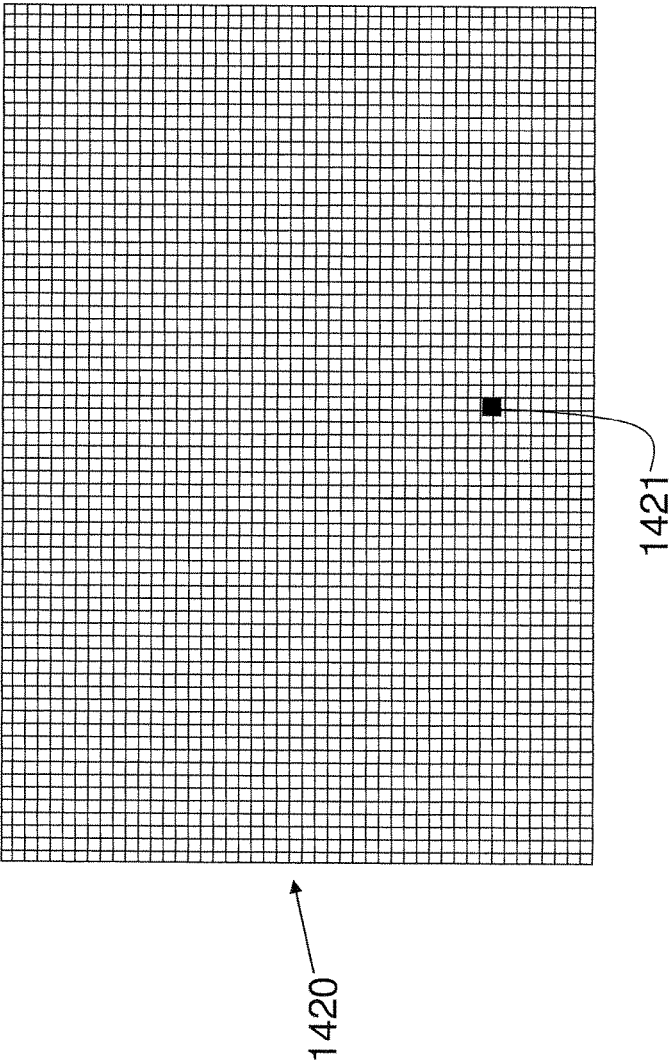
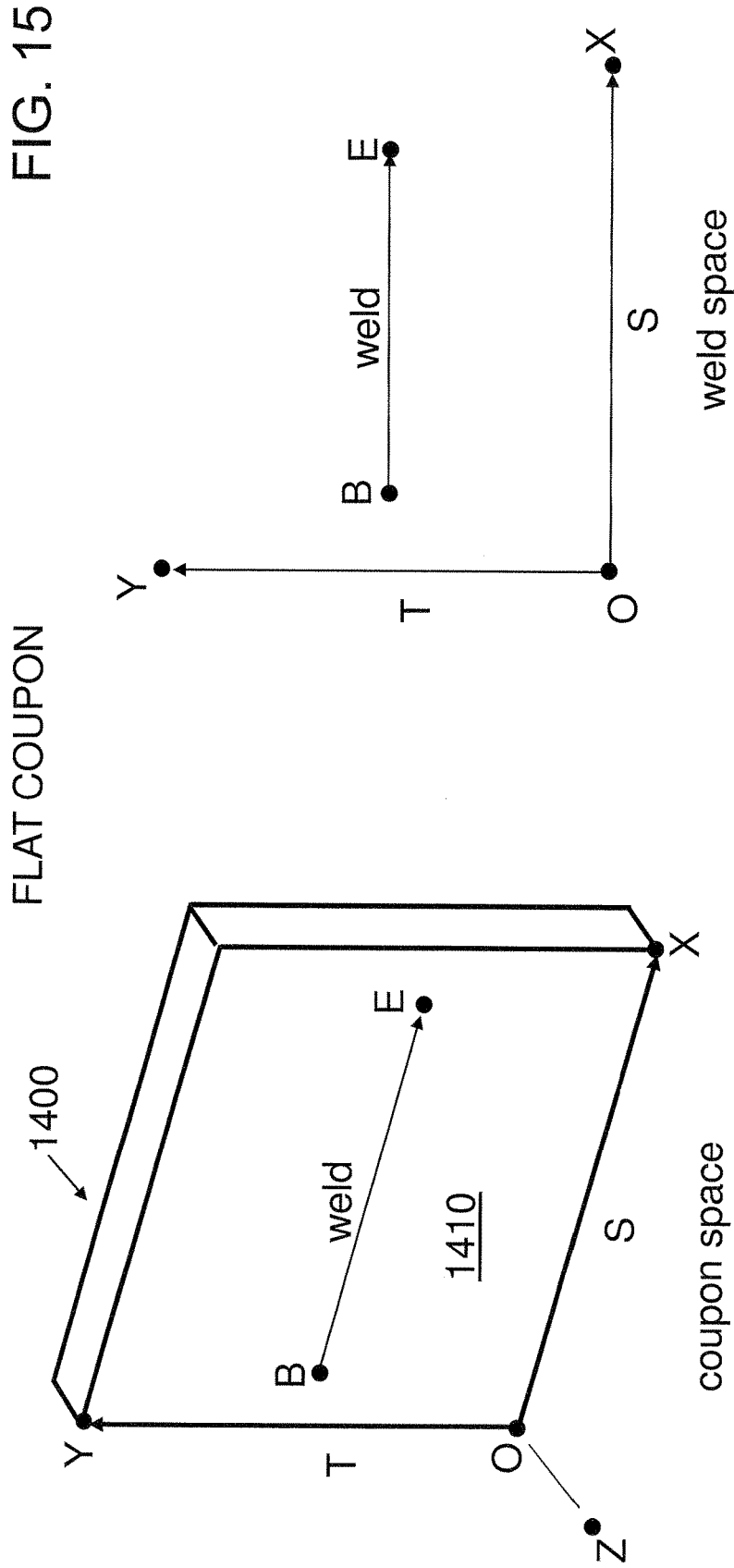

FIG. 14B





$$\text{Width} = |X-O|$$

$$\text{Height} = |Y-O|$$

$$\text{Displacement} = |Z-O|$$



FIG. 16

CORNER COUPON

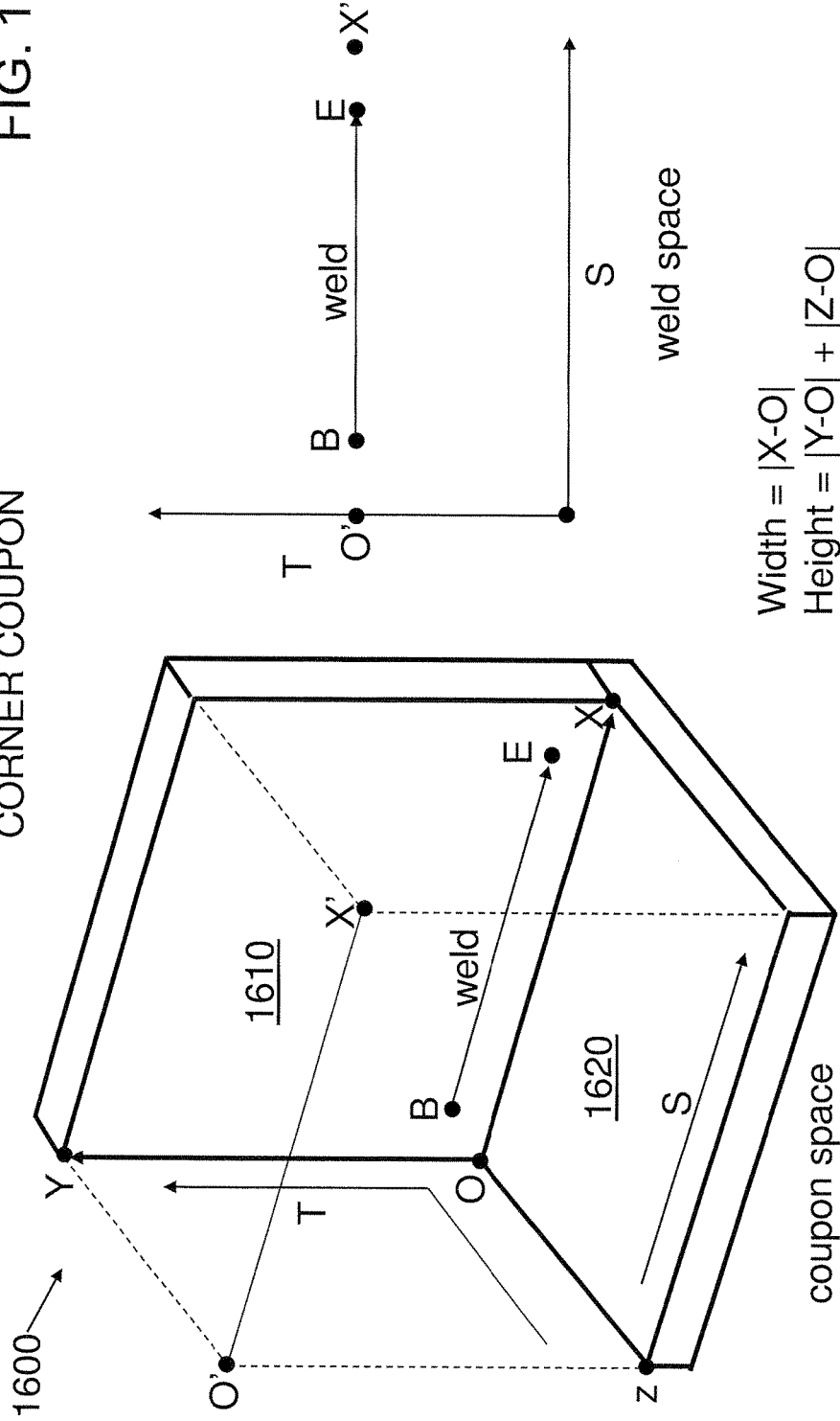

Width =  $|X-O|$   
 Height =  $|Y-O| + |Z-O|$   
 $O' = Z + Y - O$   
 $X' = O' + X - O$

Displacement is towards the line

$\overline{X' - O'}$

FIG.17

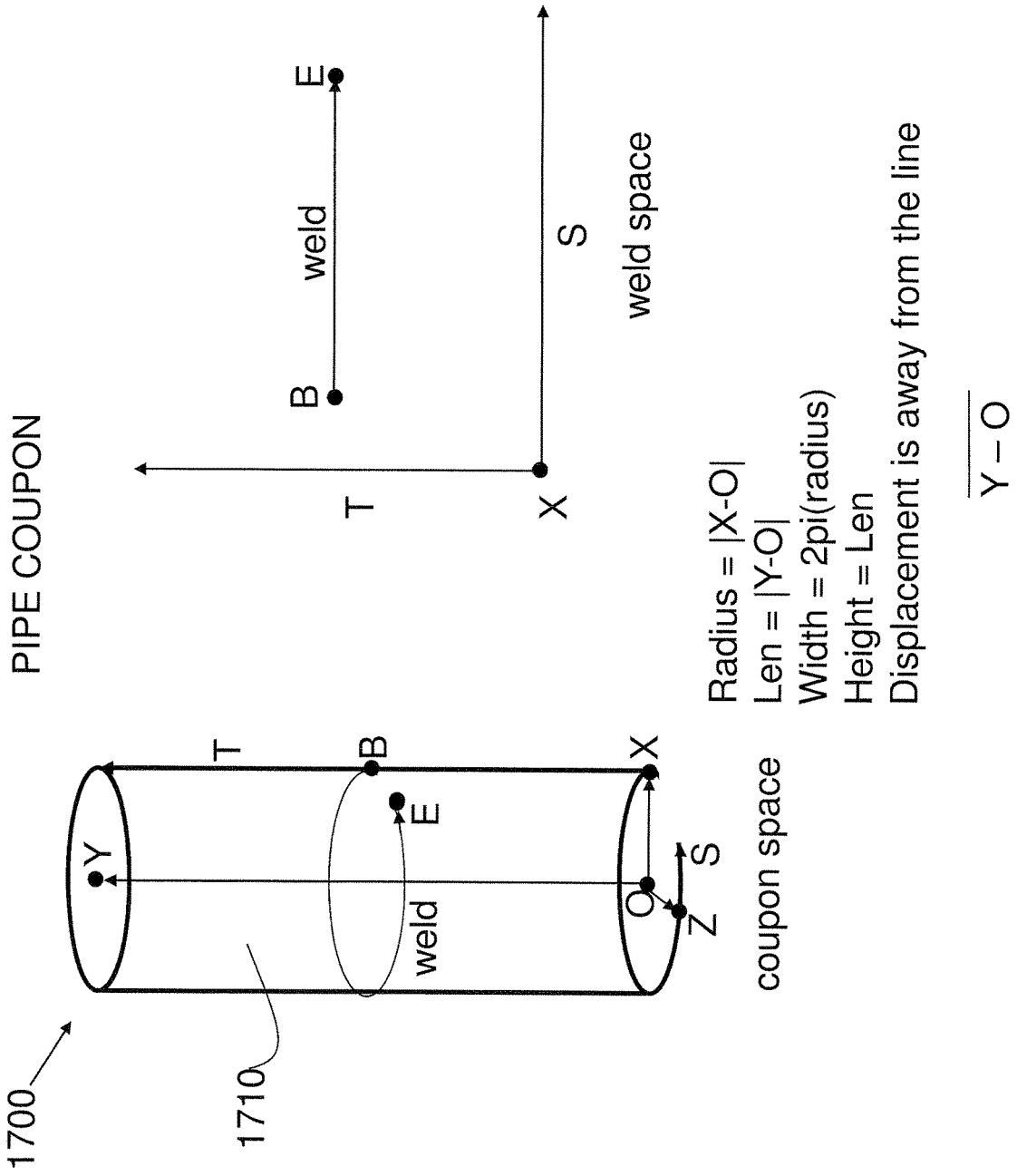

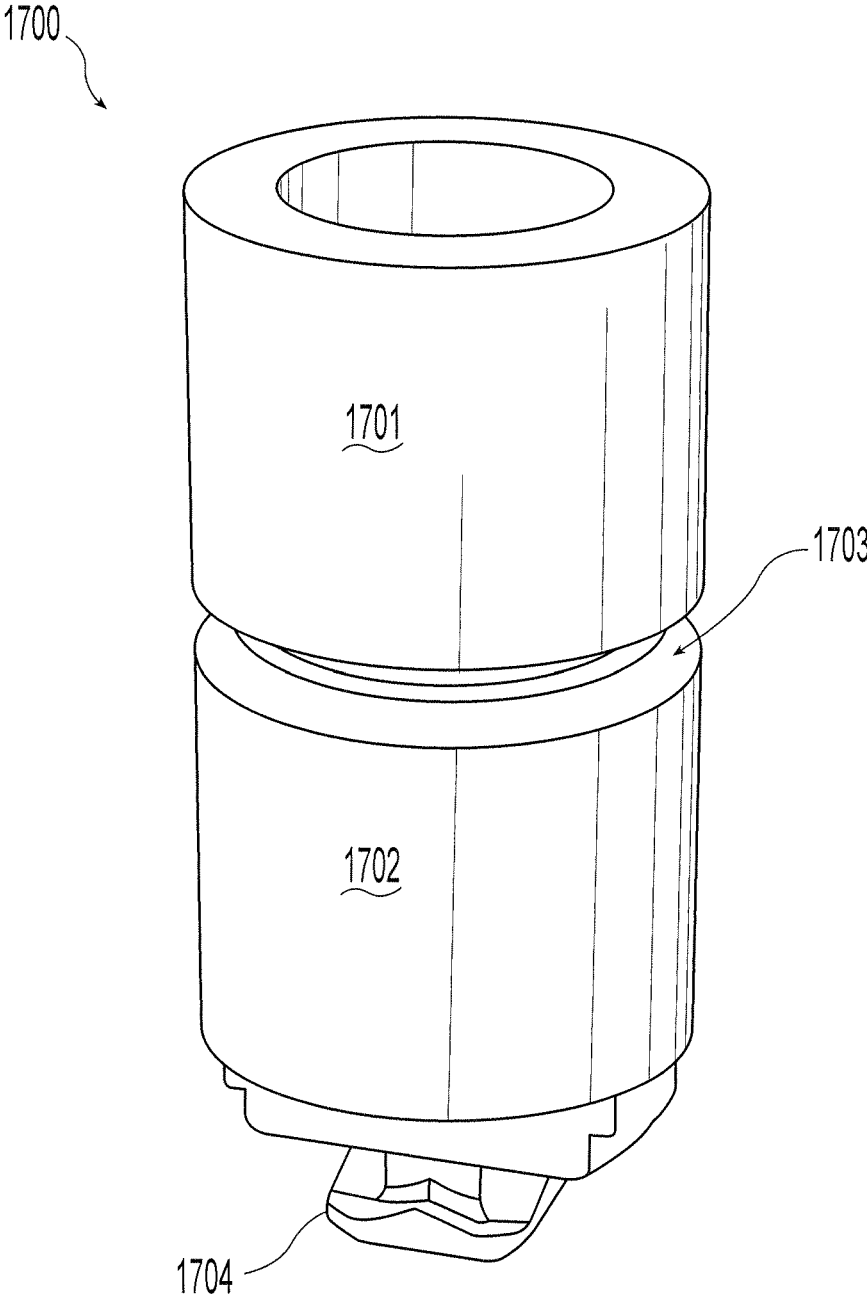

Fig. 18

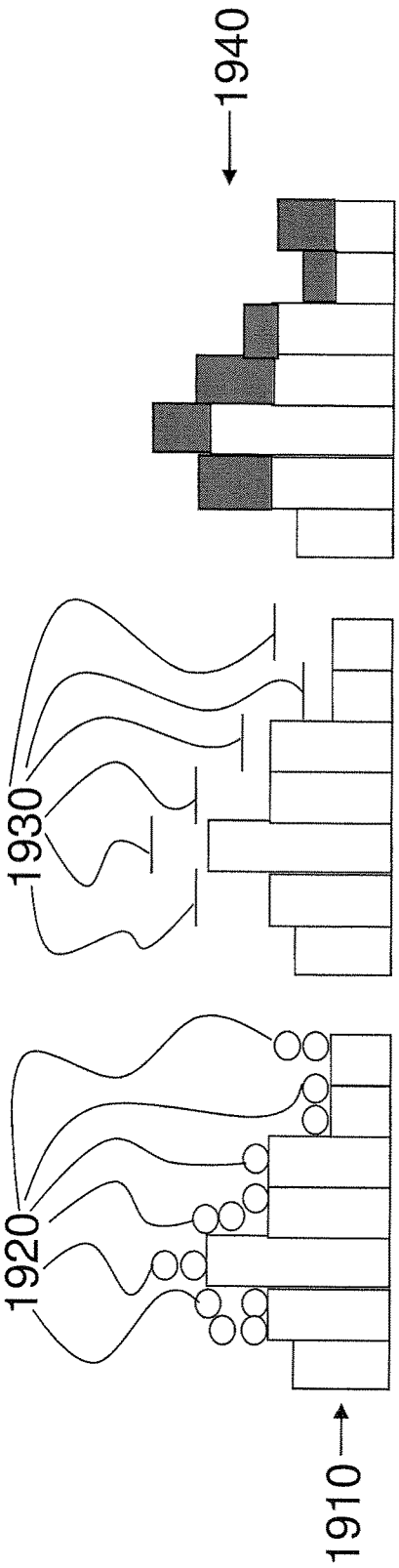

FIG. 19C

FIG. 19B

FIG. 19A

FIG. 20

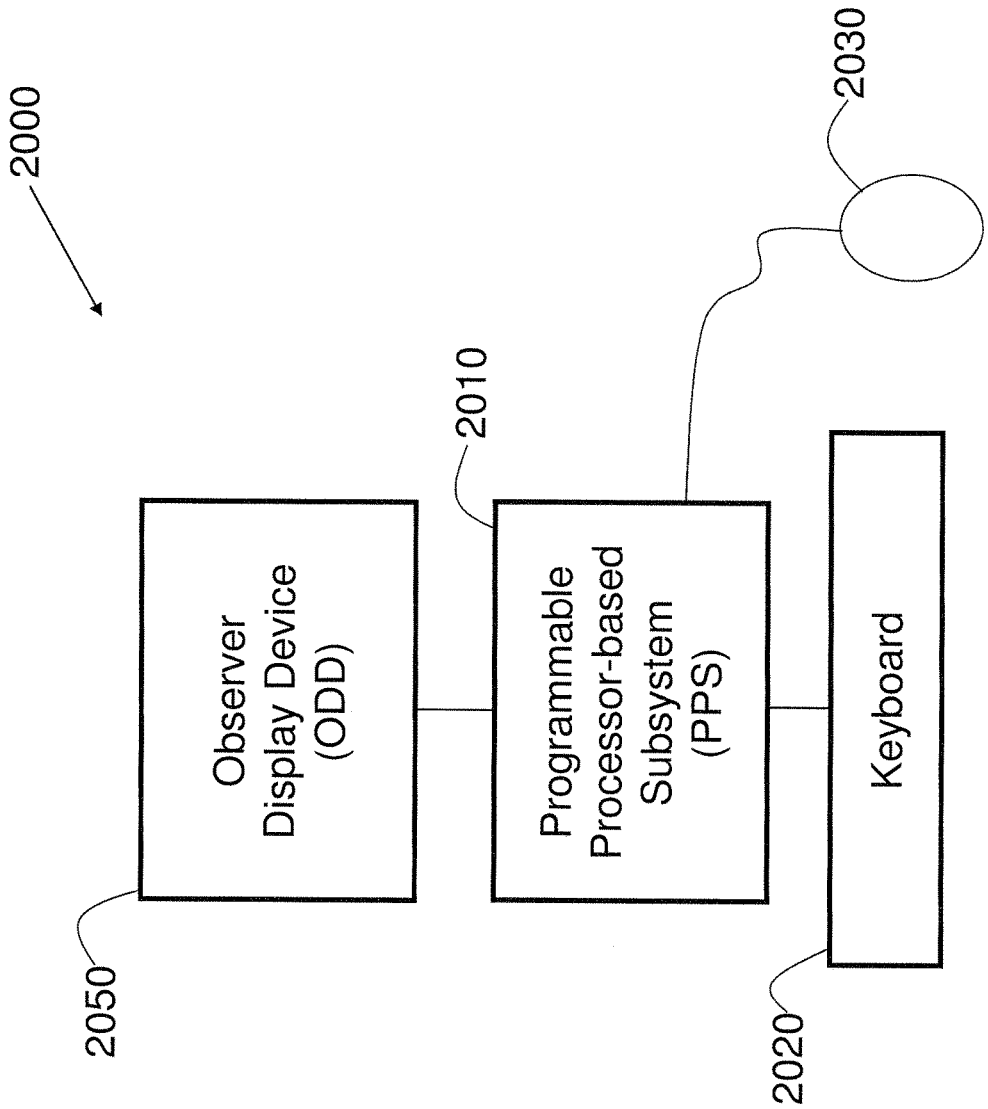

FIG. 21

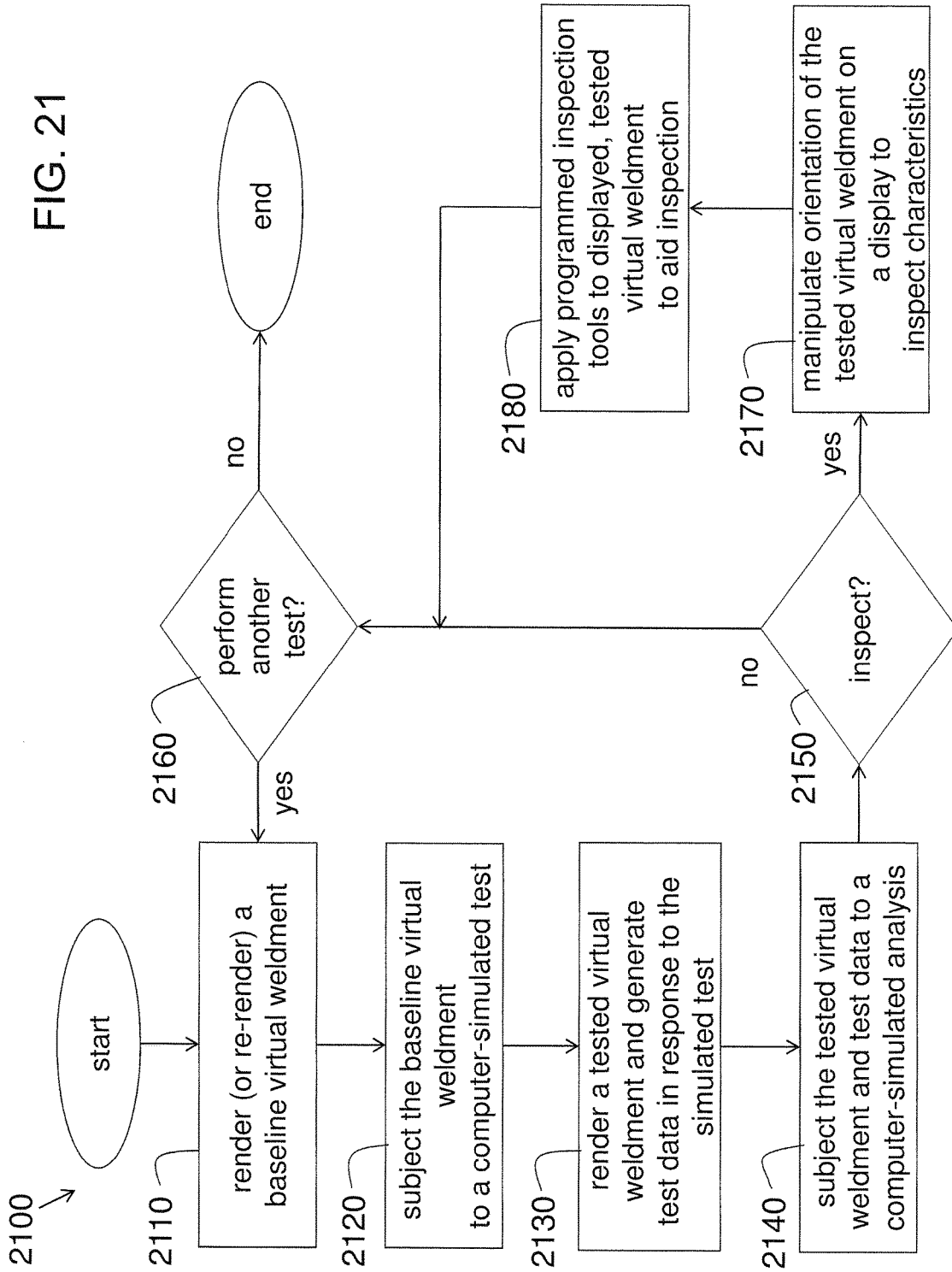

Fig. 22

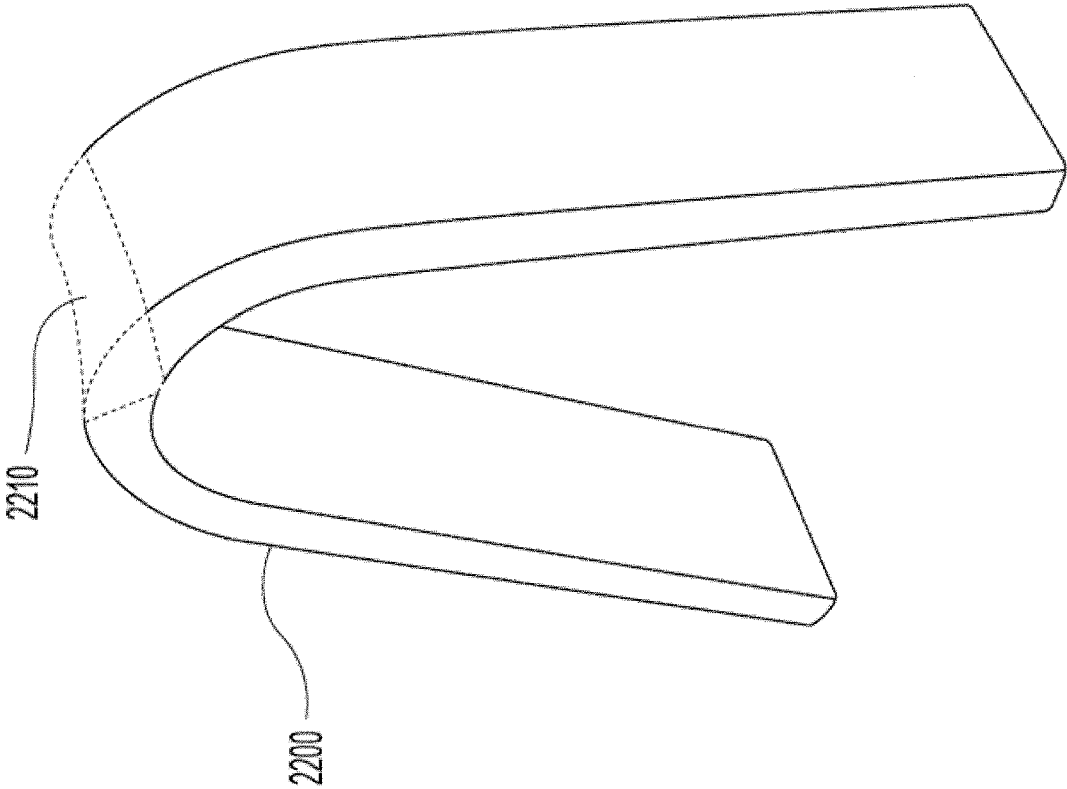

Fig. 23

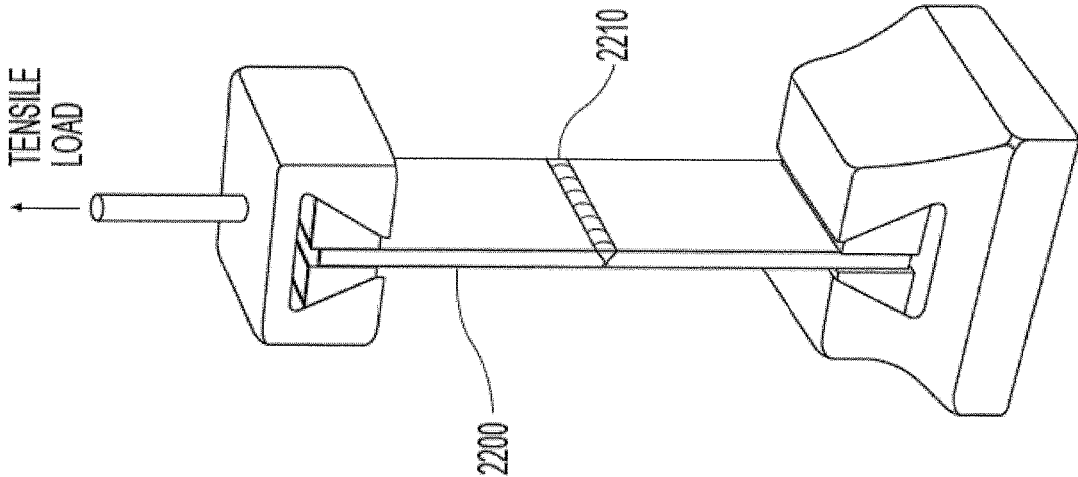
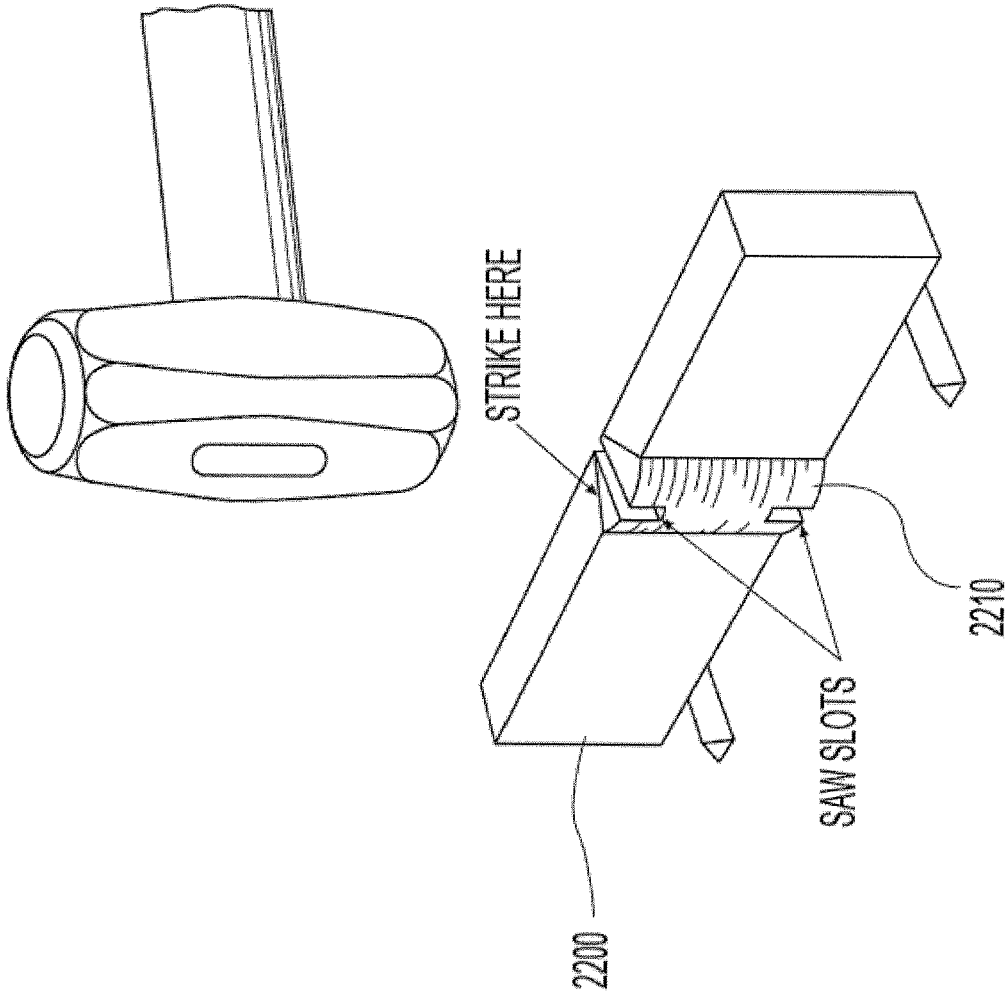



Fig. 24



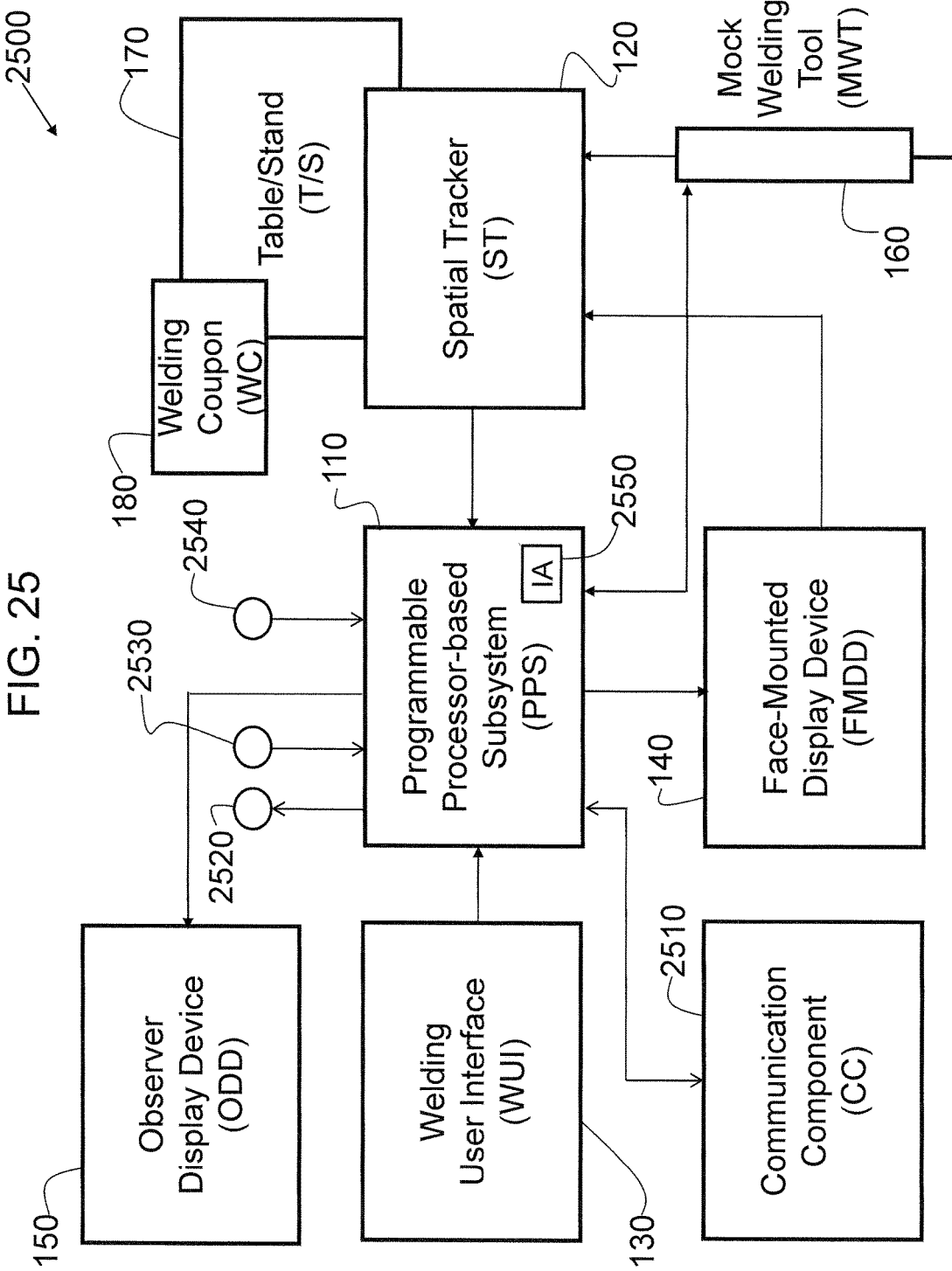

FIG. 26

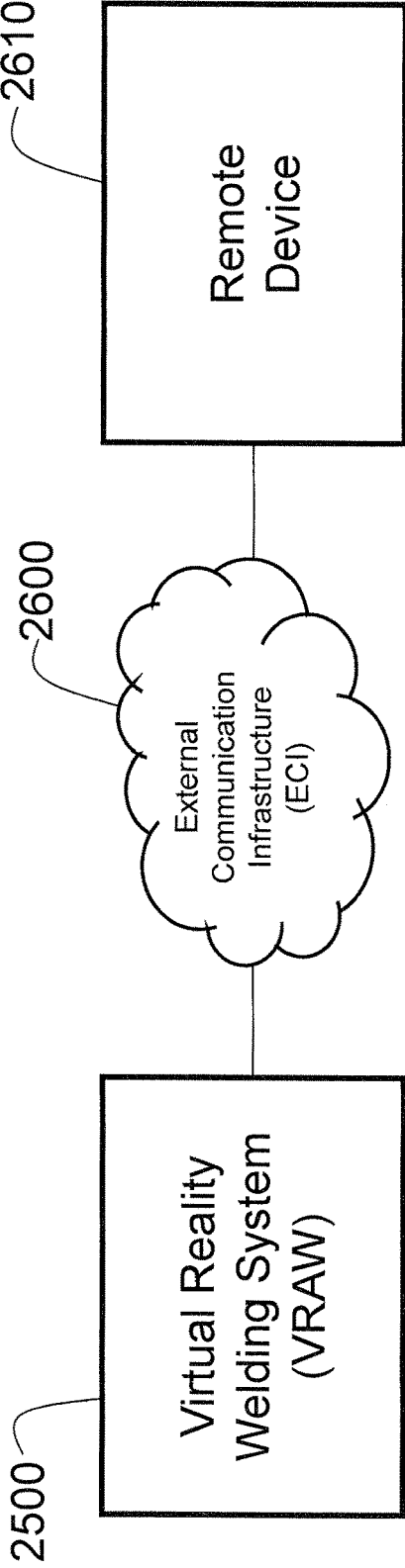

FIG. 27

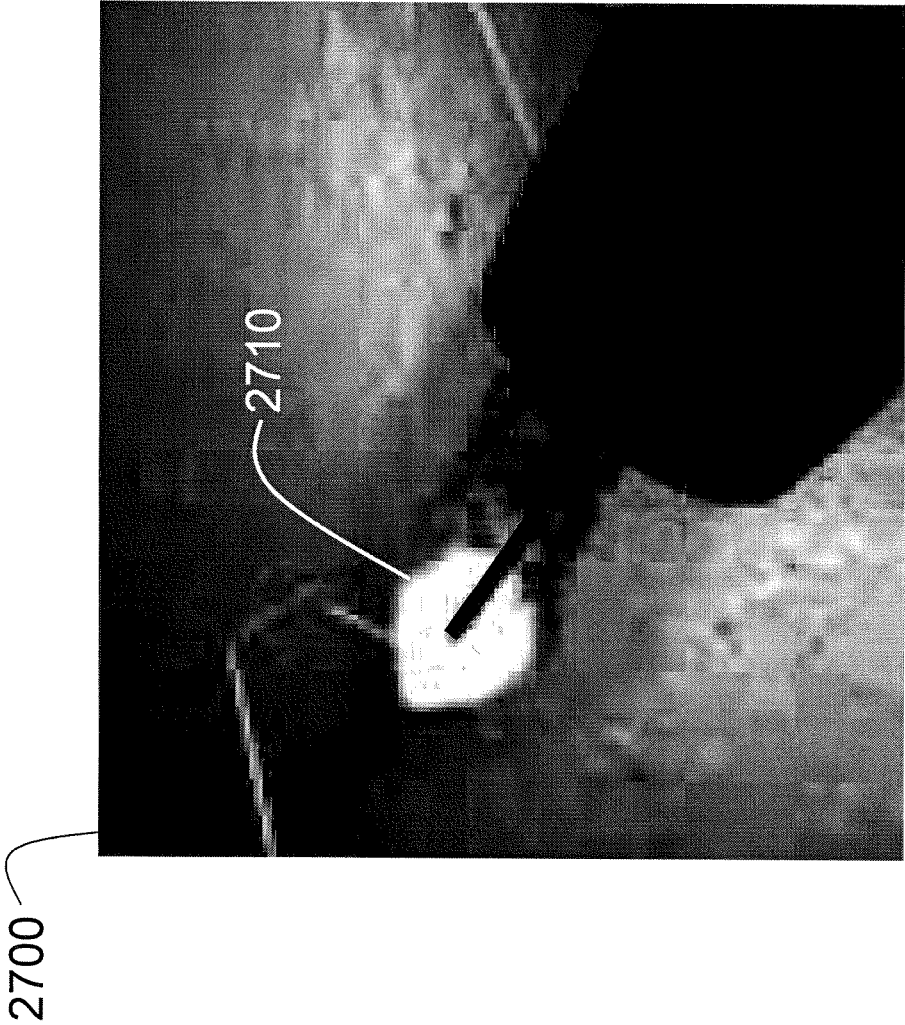
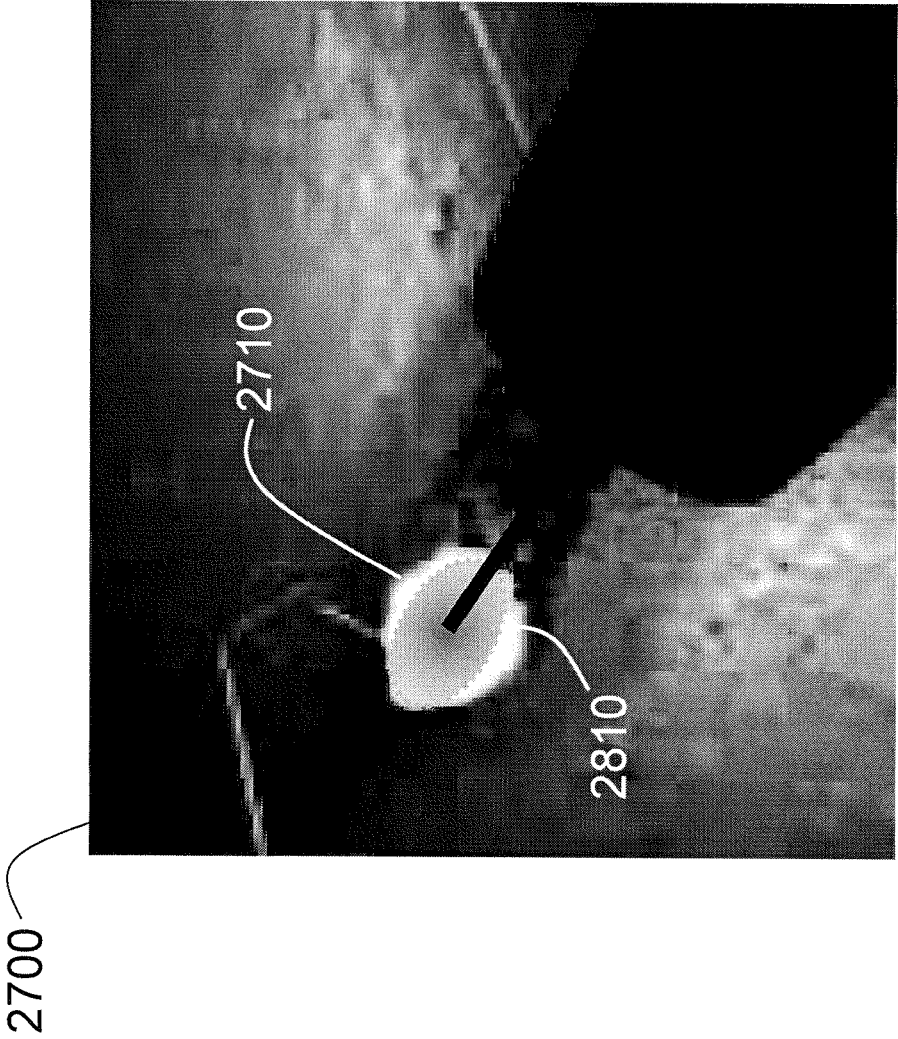

FIG. 28



## SYSTEMS AND METHODS PROVIDING ENHANCED EDUCATION AND TRAINING IN A VIRTUAL REALITY ENVIRONMENT

[0001] This U.S. patent application claims priority to and is a continuation patent application of pending U.S. patent application Ser. No. 14/248,780 filed on Apr. 9, 2014 which is incorporated herein by reference in its entirety. U.S. patent application Ser. No. 14/248,780 claims priority to and is a divisional patent application of U.S. patent application Ser. No. 13/792,300 filed on March 11, 2013 which is incorporated herein by reference in its entirety. U.S. patent application Ser. No. 13/792,300 claims priority to and is a continuation-in-part (CIP) patent application of U.S. patent application Ser. No. 13/081,725 filed on Apr. 7, 2011 (now U.S. Pat. No. 8,657,605 issued Feb. 25, 2014) which is incorporated herein by reference in its entirety and which claims priority to U.S. provisional patent application Ser. No. 61/349,029 filed on May 27, 2010. U.S. patent application Ser. No. 13/081,725 also claims priority to and is a continuation-in-part (CIP) patent application of U.S. patent application Ser. No. 12/501,257 filed on Jul. 10, 2009 which is incorporated herein by reference in its entirety and which claims priority to U.S. provisional patent application Ser. No. 61/090,794 filed on Aug. 21, 2008.

### TECHNICAL FIELD

[0002] Certain embodiments relate to virtual reality simulation. More particularly, certain embodiments relate to systems and methods for enhancing welding education and training in a virtual environment.

### BACKGROUND

[0003] In real world welding and training, a welding student may have to use real welding equipment and materials which can be expensive. Furthermore, a real world welding environment can present safety hazards to the student and, therefore, an instructing institution may have to carry significant liability insurance which can be costly. The ability for a welding student to easily understand what he is doing incorrectly, and to make corrections, can take much time in a real world welding environment and consume much time of a welding instructor. Furthermore, the ability to readily access additional educational materials or welding instructor help may be very limited in real world welding environment.

[0004] Further limitations and disadvantages of conventional, traditional, and proposed approaches will become apparent to one of skill in the art, through comparison of such approaches with embodiments of the present invention as set forth in the remainder of the present application with reference to the drawings.

### SUMMARY

[0005] One embodiment provides a virtual reality arc welding system. The system includes a programmable processor-based subsystem operable to execute coded instructions. The coded instructions include a rendering engine configured to generate a three-dimensional (3D) rendering of a virtual weldment created by a user on the virtual reality welding system. The coded instructions further include an analysis engine configured to perform simulated testing of the 3D virtual weldment and generate corresponding test

data. The coded instructions also include at least one intelligent agent (IA) configured to generate recommended corrective actions for the user, based on at least the test data.

[0006] These and other features of the claimed invention, as well as details of illustrated embodiments thereof, will be more fully understood from the following description and drawings.

### BRIEF DESCRIPTION OF THE DRAWINGS

[0007] FIG. 1 illustrates an example embodiment of a system block diagram of a system providing arc welding training in a real-time virtual reality environment;

[0008] FIG. 2 illustrates an example embodiment of a combined simulated welding console and observer display device (ODD) of the system of FIG. 1;

[0009] FIG. 3 illustrates an example embodiment of the observer display device (ODD) of FIG. 2;

[0010] FIG. 4 illustrates an example embodiment of a front portion of the simulated welding console of FIG. 2 showing a physical welding user interface (WUI);

[0011] FIG. 5 illustrates an example embodiment of a mock welding tool (MWT) of the system of FIG. 1;

[0012] FIG. 6 illustrates an example embodiment of a table/stand (T/S) of the system of FIG. 1;

[0013] FIG. 7A illustrates an example embodiment of a pipe welding coupon (W/C) of the system of FIG. 1;

[0014] FIG. 7B illustrates the pipe WC of FIG. 7A mounted in an arm of the table/stand (TS) of FIG. 6;

[0015] FIG. 8 illustrates various elements of an example embodiment of the spatial tracker (ST) of FIG. 1;

[0016] FIG. 9A illustrates an example embodiment of a face-mounted display device (FMDD) of the system of FIG. 1;

[0017] FIG. 9B is an illustration of how the FMDD of FIG. 9A is secured on the head of a user;

[0018] FIG. 9C illustrates an example embodiment of the FMDD of FIG. 9A mounted within a welding helmet;

[0019] FIG. 10 illustrates an example embodiment of a subsystem block diagram of a programmable processor-based subsystem (PPS) of the system of FIG. 1;

[0020] FIG. 11 illustrates an example embodiment of a block diagram of a graphics processing unit (GPU) of the PPS of FIG. 10;

[0021] FIG. 12 illustrates an example embodiment of a functional block diagram of the system of FIG. 1;

[0022] FIG. 13 is a flow chart of an embodiment of a method of training using the virtual reality training system of FIG. 1;

[0023] FIGS. 14A-14B illustrate the concept of a welding pixel (wexel) displacement map, in accordance with an embodiment of the present invention;

[0024] FIG. 15 illustrates an example embodiment of a coupon space and a weld space of a flat welding coupon (WC) simulated in the system of FIG. 1;

[0025] FIG. 16 illustrates an example embodiment of a coupon space and a weld space of a corner (tee joint) welding coupon (WC) simulated in the system of FIG. 1;

[0026] FIG. 17 illustrates an example embodiment of a coupon space and a weld space of a pipe welding coupon (WC) simulated in the system of FIG. 1;

[0027] FIG. 18 illustrates an example embodiment of the pipe welding coupon (WC) of FIG. 17;

[0028] FIGS. 19A-19C illustrate an example embodiment of the concept of a dual-displacement puddle model of the system of FIG. 1;

[0029] FIG. 20 illustrates an example embodiment of a standalone virtual weldment inspection (VWI) system capable of simulating inspection of a virtual weldment and displaying an animation of the virtual weldment under inspection to observe the effects due to various characteristics associated with the weldment;

[0030] FIG. 21 illustrates a flow chart of an example embodiment of a method to assess the quality of a rendered baseline virtual weldment in virtual reality space;

[0031] FIGS. 22-24 illustrate embodiments of virtual animations of a simulated bend test, a simulated pull test, and a simulated break test for a same virtual section of a weldment;

[0032] FIG. 25 illustrates a second example embodiment of a system block diagram of a system providing arc welding training in a real-time virtual reality environment;

[0033] FIG. 26 illustrates a system block diagram showing how the virtual reality arc welding system of FIG. 25 may interface to a remote device via an external communication infrastructure;

[0034] FIG. 27 illustrates an example embodiment of a displayed virtual weld, being created using the virtual reality arc welding system of FIG. 1 or FIG. 25 during a virtual welding process, showing a simulated weld puddle; and

[0035] FIG. 28 illustrates the displayed virtual weld of FIG. 27 with an image of an ideal weld puddle overlaid onto an image of the simulated weld puddle.

#### DETAILED DESCRIPTION

[0036] Data representing defects or discontinuities may be captured as part of the definition of a virtual weldment, either by pre-defining the virtual weldment or by creating a virtual weldment using a virtual reality welding simulator system (e.g., a virtual reality arc welding (VRAW) system) as part of a virtual welding process. The VRAW system comprises a programmable processor-based subsystem, a spatial tracker operatively connected to the programmable processor-based subsystem, at least one mock welding tool capable of being spatially tracked by the spatial tracker, and at least one display device operatively connected to the programmable processor-based subsystem. The system is capable of simulating, in a virtual reality space, a weld puddle having real-time molten metal fluidity and heat dissipation characteristics. The system is also capable of displaying the simulated weld puddle on the display device in real-time. The real-time molten metal fluidity and heat dissipation characteristics of the simulated weld puddle provide real-time visual feedback to a user of the mock welding tool when displayed, allowing the user to adjust or maintain a welding technique in real-time in response to the real-time visual feedback (i.e., helps the user learn to weld correctly). The displayed weld puddle is representative of a weld puddle that would be formed in the real-world based on the user's welding technique and the selected welding process and parameters. By viewing a puddle (e.g., shape, color, slag, size, stacked dimes), a user can modify his technique to make a good weld and determine the type of welding being done. The shape of the puddle is responsive to the movement of the gun or stick. As used herein, the term "real-time" means perceiving and experiencing in time in a simulated environment in the same way that a user would

perceive and experience in a real-world welding scenario. Furthermore, the weld puddle is responsive to the effects of the physical environment including gravity, allowing a user to realistically practice welding in various positions including overhead welding and various pipe welding angles (e.g., 1G, 2G, 5G, 6G). Such a real-time virtual welding scenario results in the generating of data representative of a virtual weldment.

[0037] FIG. 1 illustrates an example embodiment of a system block diagram of a system 100 providing arc welding training in a real-time virtual reality environment. The system 100 includes a programmable processor-based subsystem (PPS) 110. The PPS 110 provides the hardware and software configured as a rendering engine for providing 3D animated renderings of virtual weldments. The PPS 110 also provides hardware and software configured as an analysis engine for performing testing and inspection of a virtual weldment. In the context of the system of FIG. 1, a virtual weldment is the resultant simulation of a welding coupon that has gone through a simulated welding process to form a weld bead or weld joint.

[0038] The system 100 further includes a spatial tracker (ST) 120 operatively connected to the PPS 110. The system 100 also includes a physical welding user interface (WUI) 130 operatively connected to the PPS 110 and a face-mounted display device (FMDD) 140 (see FIGS. 9A-9C) operatively connected to the PPS 110 and the ST 120. However, certain embodiments may not provide a FMDD. The system 100 further includes an observer display device (ODD) 150 operatively connected to the PPS 110. The system 100 also includes at least one mock welding tool (MWT) 160 operatively connected to the ST 120 and the PPS 110. The system 100 further includes a table/stand (T/S) 170 and at least one welding coupon (WC) 180 capable of being attached to the T/S 170. In accordance with an alternative embodiment of the present invention, a mock gas bottle is provided (not shown) simulating a source of shielding gas and having an adjustable flow regulator.

[0039] FIG. 2 illustrates an example embodiment of a combined simulated welding console 135 (simulating a welding power source user interface) and observer display device (ODD) 150 of the system 100 of FIG. 1. The physical WUI 130 resides on a front portion of the console 135 and provides knobs, buttons, and a joystick for user selection of various modes and functions. The ODD 150 is attached to a top portion of the console 135, in accordance with an embodiment of the present invention. The MWT 160 rests in a holder attached to a side portion of the console 135. Internally, the console 135 holds the PPS 110 and a portion of the ST 120.

[0040] FIG. 3 illustrates an example embodiment of the observer display device (ODD) 150 of FIG. 2. In accordance with an embodiment of the present invention, the ODD 150 is a liquid crystal display (LCD) device. Other display devices are possible as well. For example, the ODD 150 may be a touchscreen display, in accordance with another embodiment of the present invention. The ODD 150 receives video (e.g., SVGA format) and display information from the PPS 110.

[0041] As shown in FIG. 3, the ODD 150 is capable of displaying a first user scene showing various welding parameters 151 including position, tip to work, weld angle, travel angle, and travel speed. These parameters may be selected and displayed in real time in graphical form and are

used to teach proper welding technique. Furthermore, as shown in FIG. 3, the ODD 150 is capable of displaying simulated welding discontinuity states 152 including, for example, improper weld size, poor bead placement, concave bead, excessive convexity, undercut, porosity, incomplete fusion, slag inclusion, excess spatter, overfill, and burn-through (melt through). Undercut is a groove melted into the base metal adjacent to the weld or weld root and left unfilled by weld metal. Undercut is often due to an incorrect angle of welding. Porosity is cavity type discontinuities formed by gas entrapment during solidification often caused by moving the arc too far away from the coupon. Such simulated welding discontinuity states are generated by the system 100 during a simulated welding process to form a virtual weldment using a simulated welding coupon.

[0042] Also, as shown in FIG. 3, the ODD 150 is capable of displaying user selections 153 including menu, actions, visual cues, new coupon, and end pass. These user selections are tied to user buttons on the console 135. As a user makes various selections via, for example, a touchscreen of the ODD 150 or via the physical WUI 130, the displayed characteristics can change to provide selected information and other options to the user. Furthermore, the ODD 150 may display a view seen by a welder wearing the FMDD 140 at the same angular view of the welder or at various different angles, for example, chosen by an instructor. The ODD 150 may be viewed by an instructor and/or students for various training purposes, including for destructive/non-destructive testing and inspection of a virtual weldment. For example, the view may be rotated around the finished weld allowing visual inspection by an instructor. In accordance with an alternate embodiment of the present invention, video from the system 100 may be sent to a remote location via, for example, the Internet for remote viewing and/or critiquing. Furthermore, audio may be provided, allowing real-time audio communication between a student and a remote instructor.

[0043] FIG. 4 illustrates an example embodiment of a front portion of the simulated welding console 135 of FIG. 2 showing a physical welding user interface (WUI) 130. The WUI 130 includes a set of buttons 131 corresponding to the user selections 153 displayed on the ODD 150. The buttons 131 are colored to correspond to the colors of the user selections 153 displayed on the ODD 150. When one of the buttons 131 is pressed, a signal is sent to the PPS 110 to activate the corresponding function. The WUI 130 also includes a joystick 132 capable of being used by a user to select various parameters and selections displayed on the ODD 150. The WUI 130 further includes a dial or knob 133 for adjusting wire feed speed/amperage, and another dial or knob 134 for adjusting volts/trim. The WUI 130 also includes a dial or knob 136 for selecting an arc welding process. In accordance with an embodiment of the present invention, three arc welding processes are selectable including flux cored arc welding (FCAW) including gas-shielded and self-shielded processes; gas metal arc welding (GMAW) including short arc, axial spray, STT, and pulse; gas tungsten arc welding (GTAW); and shielded metal arc welding (SMAW) including E6010, E6013, and E7018 electrodes. The WUI 130 further includes a dial or knob 137 for selecting a welding polarity. In accordance with an embodiment of the present invention, three arc welding polarities are selectable including alternating current (AC), positive direct current (DC+), and negative direct current (DC-).

[0044] FIG. 5 illustrates an example embodiment of a mock welding tool (MWT) 160 of the system 100 of FIG. 1. The MWT 160 of FIG. 5 simulates a stick welding tool for plate and pipe welding and includes a holder 161 and a simulated stick electrode 162. A trigger on the MWT 160 is used to communicate a signal to the PPS 110 to activate a selected simulated welding process. The simulated stick electrode 162 includes a tactilely resistive tip 163 to simulate resistive feedback that occurs during, for example, a root pass welding procedure in real-world pipe welding or when welding a plate. If the user moves the simulated stick electrode 162 too far back out of the root, the user will be able to feel or sense the lower resistance, thereby deriving feedback for use in adjusting or maintaining the current welding process.

[0045] It is contemplated that the stick welding tool may incorporate an actuator, not shown, that withdraws the simulated stick electrode 162 during the virtual welding process. That is to say that as a user engages in virtual welding activity, the distance between holder 161 and the tip of the simulated stick electrode 162 is reduced to simulate consumption of the electrode. The consumption rate, i.e. withdrawal of the stick electrode 162, may be controlled by the PPS 110 and more specifically by coded instructions executed by the PPS 110. The simulated consumption rate may also depend on the user's technique. It is noteworthy to mention here that as the system 100 facilitates virtual welding with different types of electrodes, the consumption rate or reduction of the stick electrode 162 may change with the welding procedure used and/or setup of the system 100.

[0046] Other mock welding tools are possible as well, in accordance with other embodiments of the present invention, including a MWD that simulates a hand-held semi-automatic welding gun having a wire electrode fed through the gun, for example. Furthermore, in accordance with other certain embodiments of the present invention, a real welding tool could be used as the MWT 160 to better simulate the actual feel of the tool in the user's hands, even though, in the system 100, the tool would not be used to actually create a real arc. Also, a simulated grinding tool may be provided, for use in a simulated grinding mode of the simulator 100. Similarly, a simulated cutting tool may be provided, for use in a simulated cutting mode of the simulator 100 such as, for example, as used in Oxyfuel and plasma cutting. Furthermore, a simulated gas tungsten arc welding (GTAW) torch or filler material may be provided for use in the simulator 100.

[0047] FIG. 6 illustrates an example embodiment of a table/stand (T/S) 170 of the system 100 of FIG. 1. The T/S 170 includes an adjustable table 171, a stand or base 172, an adjustable arm 173, and a vertical post 174. The table 171, the stand 172, and the arm 173 are each attached to the vertical post 174. The table 171 and the arm 173 are each capable of being manually adjusted upward, downward, and rotationally with respect to the vertical post 174. The arm 173 is used to hold various welding coupons (e.g., welding coupon 175) and a user may rest his/her arm on the table 171 when training. The vertical post 174 is indexed with position information such that a user may know exactly where the arm 173 and the table 171 are vertically positioned on the post 174. This vertical position information may be entered into the system by a user using the WUI 130 and the ODD 150.



[0048] In accordance with an alternative embodiment of the present invention, the positions of the table 171 and the arm 173 may be automatically set by the PSS 110 via preprogrammed settings, or via the WUI 130 and/or the ODD 150 as commanded by a user. In such an alternative embodiment, the T/S 170 includes, for example, motors and/or servo-mechanisms, and signal commands from the PPS 110 activate the motors and/or servo-mechanisms. In accordance with a further alternative embodiment of the present invention, the positions of the table 171 and the arm 173 and the type of coupon are detected by the system 100. In this way, a user does not have to manually input the position information via the user interface. In such an alternative embodiment, the T/S 170 includes position and orientation detectors and sends signal commands to the PPS 110 to provide position and orientation information, and the WC 175 includes position detecting sensors (e.g., coiled sensors for detecting magnetic fields). A user is able to see a rendering of the T/S 170 adjust on the ODD 150 as the adjustment parameters are changed, in accordance with an embodiment of the present invention.

[0049] FIG. 7A illustrates an example embodiment of a pipe welding coupon (WC) 175 of the system 100 of FIG. 1. The WC 175 simulates two six inch diameter pipes 175' and 175" placed together to form a root 176 to be welded. The WC 175 includes a connection portion 177 at one end of the WC 175, allowing the WC 175 to be attached in a precise and repeatable manner to the arm 173. FIG. 7B illustrates the pipe WC 175 of FIG. 7A mounted on the arm 173 of the table/stand (TS) 170 of FIG. 6. The precise and repeatable manner in which the WC 175 is capable of being attached to the arm 173 allows for spatial calibration of the WC 175 to be performed only once at the factory. Then, in the field, as long as the system 100 is told the position of the arm 173, the system 100 is able to track the MWT 160 and the FMDD 140 with respect to the WC 175 in a virtual environment. A first portion of the arm 173, to which the WC 175 is attached, is capable of being tilted with respect to a second portion of the arm 173, as shown in FIG. 6. This allows the user to practice pipe welding with the pipe in any of several different orientations and angles.

[0050] FIG. 8 illustrates various elements of an example embodiment of the spatial tracker (ST) 120 of FIG. 1. The ST 120 is a magnetic tracker that is capable of operatively interfacing with the PPS 110 of the system 100. The ST 120 includes a magnetic source 121 and source cable, at least one sensor 122 and associated cable, host software on disk 123, a power source 124 and associated cable, USB and RS-232 cables 125, and a processor tracking unit 126. The magnetic source 121 is capable of being operatively connected to the processor tracking unit 126 via a cable. The sensor 122 is capable of being operatively connected to the processor tracking unit 126 via a cable. The power source 124 is capable of being operatively connected to the processor tracking unit 126 via a cable. The processor tracking unit 126 is cable of being operatively connected to the PPS 110 via a USB or RS-232 cable 125. The host software on disk 123 is capable of being loaded onto the PPS 110 and allows functional communication between the ST 120 and the PPS 110.

[0051] Referring to FIG. 6 and FIG. 8, the magnetic source 121 of the ST 120 is mounted on the first portion of the arm 173. The magnetic source 121 creates a magnetic field around the source 121, including the space encompassing

the WC 175 attached to the arm 173, which establishes a 3D spatial frame of reference. The T/S 170 is largely non-metallic (non-ferric and non-conductive) so as not to distort the magnetic field created by the magnetic source 121. The sensor 122 includes three induction coils orthogonally aligned along three spatial directions. The induction coils of the sensor 122 each measure the strength of the magnetic field in each of the three directions and provide that information to the processor tracking unit 126. As a result, the system 100 is able to know where any portion of the WC 175 is with respect to the 3D spatial frame of reference established by the magnetic field when the WC 175 is mounted on the arm 173. The sensor 122 may be attached to the MWT 160 or to the FMDD 140, allowing the MWT 160 or the FMDD 140 to be tracked by the ST 120 with respect to the 3D spatial frame of reference in both space and orientation. When two sensors 122 are provided and operatively connected to the processor tracking unit 126, both the MWT 160 and the FMDD 140 may be tracked. In this manner, the system 100 is capable of creating a virtual WC, a virtual MWT, and a virtual T/S in virtual reality space and displaying the virtual WC, the virtual MWT, and the virtual T/S on the FMDD 140 and/or the ODD 150 as the MWT 160 and the FMDD 140 are tracked with respect to the 3D spatial frame of reference.

[0052] In accordance with an alternative embodiment of the present invention, the sensor(s) 122 may wirelessly interface to the processor tracking unit 126, and the processor tracking unit 126 may wirelessly interface to the PPS 110. In accordance with other alternative embodiments of the present invention, other types of spatial trackers 120 may be used in the system 100 including, for example, an accelerometer/gyroscope-based tracker, an optical tracker (active or passive), an infrared tracker, an acoustic tracker, a laser tracker, a radio frequency tracker, an inertial tracker, and augmented reality based tracking systems. Other types of trackers may be possible as well.

[0053] FIG. 9A illustrates an example embodiment of the face-mounted display device 140 (FMDD) of the system 100 of FIG. 1. FIG. 9B is an illustration of how the FMDD 140 of FIG. 9A is secured on the head of a user. FIG. 9C illustrates an example embodiment of the FMDD 140 of FIG. 9A integrated into a welding helmet 900. The FMDD 140 operatively connects to the PPS 110 and the ST 120 either via wired means or wirelessly. A sensor 122 of the ST 120 may be attached to the FMDD 140 or to the welding helmet 900, in accordance with various embodiments of the present invention, allowing the FMDD 140 and/or welding helmet 900 to be tracked with respect to the 3D spatial frame of reference created by the ST 120.

[0054] In accordance with an embodiment of the present invention, the FMDD 140 includes two high-contrast SVGA 3D OLED microdisplays capable of delivering fluid full-motion video in the 2D and frame sequential video modes. Video of the virtual reality environment is provided and displayed on the FMDD 140. A zoom (e.g., 2x) mode may be provided, allowing a user to simulate a cheater lens, for example.

[0055] The FMDD 140 further includes two earbud speakers 910, allowing the user to hear simulated welding-related and environmental sounds produced by the system 100. The FMDD 140 may operatively interface to the PPS 110 via wired or wireless means, in accordance with various embodiments of the present invention. In accordance with

an embodiment of the present invention, the PPS 110 provides stereoscopic video to the FMDD 140, providing enhanced depth perception to the user. In accordance with an alternate embodiment of the present invention, a user is able to use a control on the MWT 160 (e.g., a button or switch) to call up and select menus and display options on the FMDD 140. This may allow the user to easily reset a weld if he makes a mistake, change certain parameters, or back up a little to re-do a portion of a weld bead trajectory, for example.

[0056] FIG. 10 illustrates an example embodiment of a subsystem block diagram of the programmable processor-based subsystem (PPS) 110 of the system 100 of FIG. 1. The PPS 110 includes a central processing unit (CPU) 111 and two graphics processing units (GPU) 115, in accordance with an embodiment of the present invention. The two GPUs 115 are programmed to provide virtual reality simulation of a weld puddle (a.k.a. a weld pool) having real-time molten metal fluidity and heat absorption and dissipation characteristics, in accordance with an embodiment of the present invention.

[0057] FIG. 11 illustrates an example embodiment of a block diagram of a graphics processing unit (GPU) 115 of the PPS 110 of FIG. 10. Each GPU 115 supports the implementation of data parallel algorithms. In accordance with an embodiment of the present invention, each GPU 115 provides two video outputs 118 and 119 capable of providing two virtual reality views. Two of the video outputs may be routed to the FMDD 140, rendering the welder's point of view, and a third video output may be routed to the ODD 150, for example, rendering either the welder's point of view or some other point of view. The remaining fourth video output may be routed to a projector, for example. Both GPUs 115 perform the same welding physics computations but may render the virtual reality environment from the same or different points of view. The GPU 115 includes a compute unified device architecture (CUDA) 116 and a shader 117. The CUDA 116 is the computing engine of the GPU 115 which is accessible to software developers through industry standard programming languages. The CUDA 116 includes parallel cores and is used to run the physics model of the weld puddle simulation described herein. The CPU 111 provides real-time welding input data to the CUDA 116 on the GPU 115. The shader 117 is responsible for drawing and applying all of the visuals of the simulation. Bead and puddle visuals are driven by the state of a weld displacement map which is described later herein. In accordance with an embodiment of the present invention, the physics model runs and updates at a rate of about 30 times per second. During virtual destructive/non-destructive testing and inspection simulations, the GPUs 115 act as a rendering engine to provide 3D animated renderings of a virtual weldment created during a simulated welding process. Furthermore, the CPU 111 acts as an analysis engine to provide testing analysis of the virtual weldment with respect to the various defects and discontinuities that may be present in the virtual weldment.

[0058] FIG. 12 illustrates an example embodiment of a functional block diagram of the system 100 of FIG. 1. The various functional blocks of the system 100 as shown in FIG. 12 are implemented largely via software instructions and modules running on the PPS 110. The various functional blocks of the system 100 include a physical interface 1201, torch and clamp models 1202, environment models 1203,

sound content functionality 1204, welding sounds 1205, stand/table model 1206, internal architecture functionality 1207, calibration functionality 1208, coupon models 1210, welding physics 1211, internal physics adjustment tool (tweaker) 1212, graphical user interface functionality 1213, graphing functionality 1214, student reports functionality 1215, renderer 1216, bead rendering 1217, 3D textures 1218, visual cues functionality 1219, scoring and tolerance functionality 1220, tolerance editor 1221, and special effects 1222. The renderer 1216, the bead rendering 1217, the 3D textures 1218, and the scoring and tolerance functionality 1220 are employed during virtual destructive/non-destructive testing and inspection as well as during a simulated welding process, in accordance with an embodiment of the present invention.

[0059] The internal architecture functionality 1207 provides the higher level software logistics of the processes of the system 100 including, for example, loading files, holding information, managing threads, turning the physics model on, and triggering menus. The internal architecture functionality 1207 runs on the CPU 111, in accordance with an embodiment of the present invention. Certain real-time inputs to the PPS 110 include arc location, gun position, FMDD or helmet position, gun on/off state, and contact made state (yes/no).

[0060] The graphical user interface functionality 1213 allows a user, through the ODD 150 using the joystick 132 of the physical user interface 130, to set up a welding scenario, a testing scenario, or an inspection scenario. In accordance with an embodiment of the present invention, the set up of a welding scenario includes selecting a language, entering a user name, selecting a practice plate (i.e., a welding coupon), selecting a welding process (e.g., FCAW, GMAW, SMAW) and associated axial spray, pulse, or short arc methods, selecting a gas type and flow rate, selecting a type of stick electrode (e.g., 6010 or 7018), and selecting a type of flux cored wire (e.g., self-shielded, gas-shielded). The set up of a welding scenario also includes selecting a table height, an arm height, an arm position, and an arm rotation of the T/S 170. The set up of a welding scenario further includes selecting an environment (e.g., a background environment in virtual reality space), setting a wire feed speed, setting a voltage level, setting an amperage, selecting a polarity, and turning particular visual cues on or off. Similarly, the set up of a virtual testing or inspection scenario may include selecting a language, entering a user name, selecting a virtual weldment, selecting a destructive or a non-destructive test, selecting an interactive tool, and selecting an animated perspective view.

[0061] During a simulated welding scenario, the graphing functionality 1214 gathers user performance parameters and provides the user performance parameters to the graphical user interface functionality 1213 for display in a graphical format (e.g., on the ODD 150). Tracking information from the ST 120 feeds into the graphing functionality 1214. The graphing functionality 1214 includes a simple analysis module (SAM) and a whip/weave analysis module (WWAM). The SAM analyzes user welding parameters including welding travel angle, travel speed, weld angle, position, and tip to work distance by comparing the welding parameters to data stored in bead tables. The WWAM analyzes user whipping parameters including dime spacing, whip time, and puddle time. The WWAM also analyzes user weaving parameters including width of weave, weave spacing, and

weave timing. The SAM and WWAM interpret raw input data (e.g., position and orientation data) into functionally usable data for graphing. For each parameter analyzed by the SAM and the WWAM, a tolerance window is defined by parameter limits around an optimum or ideal set point input into bead tables using the tolerance editor 1221, and scoring and tolerance functionality 1220 is performed.

[0062] The tolerance editor 1221 includes a weldometer which approximates material usage, electrical usage, and welding time. Furthermore, when certain parameters are out of tolerance, welding discontinuities (i.e., welding defects) may occur. The state of any welding discontinuities are processed by the graphing functionality 1214 and presented via the graphical user interface functionality 1213 in a graphical format. Such welding discontinuities include improper weld size, poor bead placement, concave bead, excessive convexity, undercut, porosity, incomplete fusion, slag entrapment, overfill, burnthrough, and excessive spatter. In accordance with an embodiment of the present invention, the level or amount of a discontinuity is dependent on how far away a particular user parameter is from the optimum or ideal set point. Such welding discontinuities that are generated as part of the simulated welding process are used as inputs to the virtual destructive/non-destructive and inspection processes as associated with a virtual weldment.

[0063] Different parameter limits may be pre-defined for different types of users such as, for example, welding novices, welding experts, and persons at a trade show. The scoring and tolerance functionality 1220 provide number scores depending on how close to optimum (ideal) a user is for a particular parameter and depending on the level of discontinuities or defects present in the weld. The optimum values are derived from real-world data. Information from the scoring and tolerance functionality 1220 and from the graphics functionality 1214 may be used by the student reports functionality 1215 to create a performance report for an instructor and/or a student.

[0064] The system 100 is capable of analyzing and displaying the results of virtual welding activity. By analyzing the results, it is meant that system 100 is capable of determining when during the welding pass and where along the weld joints, the user deviated from the acceptable limits of the welding process. A score may be attributed to the users performance. In one embodiment, the score may be a function of deviation in position, orientation and speed of the mock welding tool 160 through ranges of tolerances, which may extend from an ideal welding pass to marginal or unacceptable welding activity. Any gradient of ranges may be incorporated into the system 100 as chosen for scoring the users performance. Scoring may be displayed numerically or alpha-numerically. Additionally, the users performance may be displayed graphically showing, in time and/or position along the weld joint, how closely the mock welding tool traversed the weld joint. Parameters such as travel angle, work angle, speed, and distance from the weld joint are examples of what may be measured, although any parameters may be analyzed for scoring purposes. The tolerance ranges of the parameters are taken from real-world welding data, thereby providing accurate feedback as to how the user will perform in the real world. In another embodiment, analysis of the defects corresponding to the users performance may also be incorporated and displayed on the ODD 150. In this embodiment, a graph may be depicted indicating what type of discontinuity resulted from measuring the

various parameters monitored during the virtual welding activity. While occlusions may not be visible on the ODD 150, defects may still have occurred as a result of the users performance, the results of which may still be correspondingly displayed, i.e. graphed, and also tested (e.g., via a bend test) and inspected.

[0065] Visual cues functionality 1219 provide immediate feedback to the user by displaying overlaid colors and indicators on the FMDD 140 and/or the ODD 150. Visual cues are provided for each of the welding parameters 151 including position, tip to work distance, weld angle, travel angle, travel speed, and arc length (e.g., for stick welding) and visually indicate to the user if some aspect of the user's welding technique should be adjusted based on the pre-defined limits or tolerances. Visual cues may also be provided for whip/weave technique and weld bead "dime" spacing, for example. Visual cues may be set independently or in any desired combination.

[0066] Calibration functionality 1208 provides the capability to match up physical components in real world space (3D frame of reference) with visual components in virtual reality space. Each different type of welding coupon (WC) is calibrated in the factory by mounting the WC to the arm 173 of the T/S 170 and touching the WC at predefined points (indicated by, for example, three dimples on the WC) with a calibration stylus operatively connected to the ST 120. The ST 120 reads the magnetic field intensities at the predefined points, provides position information to the PPS 110, and the PPS 110 uses the position information to perform the calibration (i.e., the translation from real world space to virtual reality space).

[0067] Any particular type of WC fits into the arm 173 of the T/S 170 in the same repeatable way to within very tight tolerances. Therefore, once a particular WC type is calibrated, that WC type does not have to be re-calibrated (i.e., calibration of a particular type of WC is a one-time event). WCs of the same type are interchangeable. Calibration ensures that physical feedback perceived by the user during a welding process matches up with what is displayed to the user in virtual reality space, making the simulation seem more real. For example, if the user slides the tip of a MWT 160 around the corner of an actual WC 180, the user will see the tip sliding around the corner of the virtual WC on the FMDD 140 as the user feels the tip sliding around the actual corner. In accordance with an embodiment of the present invention, the MWT 160 is placed in a pre-positioned jig and is calibrated as well, based on the known jig position.

[0068] In accordance with an alternative embodiment of the present invention, "smart" coupons are provided, having sensors on, for example, the corners of the coupons. The ST 120 is able to track the corners of a "smart" coupon such that the system 100 continuously knows where the "smart" coupon is in real world 3D space. In accordance with a further alternative embodiment of the present invention, licensing keys are provided to "unlock" welding coupons. When a particular WC is purchased, a licensing key is provided allowing the user to enter the licensing key into the system 100, unlocking the software associated with that WC. In accordance with another embodiment of the present invention, special non-standard welding coupons may be provided based on real-world CAD drawings of parts. Users may be able to train on welding a CAD part even before the part is actually produced in the real world.

[0069] Sound content functionality 1204 and welding sounds 1205 provide particular types of welding sounds that change depending on if certain welding parameters are within tolerance or out of tolerance. Sounds are tailored to the various welding processes and parameters. For example, in a MIG spray arc welding process, a crackling sound is provided when the user does not have the MWT 160 positioned correctly, and a hissing sound is provided when the MWT 160 is positioned correctly. In a short arc welding process, a steady crackling or frying sound is provided for proper welding technique, and a hissing sound may be provided when undercutting is occurring. These sounds mimic real world sounds corresponding to correct and incorrect welding technique.

[0070] High fidelity sound content may be taken from real world recordings of actual welding using a variety of electronic and mechanical means, in accordance with various embodiments of the present invention. In accordance with an embodiment of the present invention, the perceived volume and directionality of sound is modified depending on the position, orientation, and distance of the user's head (assuming the user is wearing a FMDD 140 that is tracked by the ST 120) with respect to the simulated arc between the MWT 160 and the WC 180. Sound may be provided to the user via ear bud speakers 910 in the FMDD 140 or via speakers configured in the console 135 or T/S 170, for example.

[0071] Environment models 1203 are provided to provide various background scenes (still and moving) in virtual reality space. Such background environments may include, for example, an indoor welding shop, an outdoor race track, a garage, etc. and may include moving cars, people, birds, clouds, and various environmental sounds. The background environment may be interactive, in accordance with an embodiment of the present invention. For example, a user may have to survey a background area, before starting welding, to ensure that the environment is appropriate (e.g., safe) for welding. Torch and clamp models 1202 are provided which model various MWTs 160 including, for example, guns, holders with stick electrodes, etc. in virtual reality space.

[0072] Coupon models 1210 are provided which model various WCs 180 including, for example, flat plate coupons, T-joint coupons, butt-joint coupons, groove-weld coupons, and pipe coupons (e.g., 2-inch diameter pipe and 6-inch diameter pipe) in virtual reality space. A stand/table model 1206 is provided which models the various parts of the T/S 170 including an adjustable table 171, a stand 172, an adjustable arm 173, and a vertical post 174 in virtual reality space. A physical interface model 1201 is provided which models the various parts of the welding user interface 130, console 135, and ODD 150 in virtual reality space. Again, the resultant simulation of a welding coupon that has gone through a simulated welding process to form a weld bead, a weld joint, a pipe-on-plate weld, a plug weld, or a lap weld is known herein as a virtual weldment with respect to the system 100. Welding coupons may be provided to support each of these scenarios.

[0073] In accordance with an embodiment of the present invention, simulation of a weld puddle or pool in virtual reality space is accomplished where the simulated weld puddle has real-time molten metal fluidity and heat dissipation characteristics. At the heart of the weld puddle simulation is the welding physics functionality 1211 (a.k.a., the

physics model) which is run on the GPUs 115, in accordance with an embodiment of the present invention. The welding physics functionality employs a double displacement layer technique to accurately model dynamic fluidity/viscosity, solidity, heat gradient (heat absorption and dissipation), puddle wake, and bead shape, and is described in more detail herein with respect to FIGS. 14A-14C.

[0074] The welding physics functionality 1211 communicates with the bead rendering functionality 1217 to render a weld bead in all states from the heated molten state to the cooled solidified state. The bead rendering functionality 1217 uses information from the welding physics functionality 1211 (e.g., heat, fluidity, displacement, dime spacing) to accurately and realistically render a weld bead in virtual reality space in real-time. The 3D textures functionality 1218 provides texture maps to the bead rendering functionality 1217 to overlay additional textures (e.g., scorching, slag, grain) onto the simulated weld bead. For example, slag may be shown rendered over a weld bead during and just after a welding process, and then removed to reveal the underlying weld bead. The renderer functionality 1216 is used to render various non-puddle specific characteristics using information from the special effects module 1222 including sparks, spatter, smoke, arc glow, fumes and gases, and certain discontinuities such as, for example, undercut and porosity.

[0075] The internal physics adjustment tool 1212 is a tweaking tool that allows various welding physics parameters to be defined, updated, and modified for the various welding processes. In accordance with an embodiment of the present invention, the internal physics adjustment tool 1212 runs on the CPU 111 and the adjusted or updated parameters are downloaded to the GPUs 115. The types of parameters that may be adjusted via the internal physics adjustment tool 1212 include parameters related to welding coupons, process parameters that allow a process to be changed without having to reset a welding coupon (allows for doing a second pass), various global parameters that can be changed without resetting the entire simulation, and other various parameters.

[0076] FIG. 13 is a flow chart of an embodiment of a method 1300 of training using the virtual reality training system 100 of FIG. 1. The method proceeds as follows: in step 1310, move a mock welding tool with respect to a welding coupon in accordance with a welding technique; in step 1320, track position and orientation of the mock welding tool in three-dimensional space using a virtual reality system; in step 1330, view a display of the virtual reality welding system showing a real-time virtual reality simulation of the mock welding tool and the welding coupon in a virtual reality space as the simulated mock welding tool deposits a simulated weld bead material onto at least one simulated surface of the simulated welding coupon by forming a simulated weld puddle in the vicinity of a simulated arc emitting from said simulated mock welding tool; in step 1340, view on the display, real-time molten metal fluidity and heat dissipation characteristics of the simulated weld puddle; in step 1350, modify in real-time, at least one aspect of the welding technique in response to viewing the real-time molten metal fluidity and heat dissipation characteristics of the simulated weld puddle.

[0077] The method 1300 illustrates how a user is able to view a weld puddle in virtual reality space and modify his welding technique in response to viewing various charac-

teristics of the simulated weld puddle, including real-time molten metal fluidity (e.g., viscosity) and heat dissipation. The user may also view and respond to other characteristics including real-time puddle wake and dime spacing. Viewing and responding to characteristics of the weld puddle is how most welding operations are actually performed in the real world. The double displacement layer modeling of the welding physics functionality **1211** run on the GPUs **115** allows for such real-time molten metal fluidity and heat dissipation characteristics to be accurately modeled and represented to the user. For example, heat dissipation determines solidification time (i.e., how much time it takes for a wexel to completely solidify).

**[0078]** Furthermore, a user may make a second pass over the weld bead material of the virtual weldment using the same or a different (e.g., a second) mock welding tool and/or welding process. In such a second pass scenario, the simulation shows the simulated mock welding tool, the welding coupon, and the original simulated weld bead material in virtual reality space as the simulated mock welding tool deposits a second simulated weld bead material merging with the first simulated weld bead material by forming a second simulated weld puddle in the vicinity of a simulated arc emitting from the simulated mock welding tool. Additional subsequent passes using the same or different welding tools or processes may be made in a similar manner. In any second or subsequent pass, the previous weld bead material is merged with the new weld bead material being deposited as a new weld puddle is formed in virtual reality space from the combination of any of the previous weld bead material, the new weld bead material, and possibly the underlying coupon material thus modifying the resultant virtual weldment, in accordance with certain embodiments of the present invention. Such subsequent passes may be needed to make a large fillet or groove weld, performed to repair a weld bead formed by a previous pass, for example, or may include a hot pass and one or more fill and cap passes after a root pass as is done in pipe welding. In accordance with various embodiments of the present invention, weld bead and base material may include mild steel, stainless steel, aluminum, nickel based alloys, or other materials.

**[0079]** FIGS. **14A-14B** illustrate the concept of a welding element (wexel) displacement map **1420**, in accordance with an embodiment of the present invention. FIG. **14A** shows a side view of a flat welding coupon (WC) **1400** having a flat top surface **1410**. The welding coupon **1400** exists in the real world as, for example, a plastic part, and also exists in virtual reality space as a simulated welding coupon. FIG. **14B** shows a representation of the top surface **1410** of the simulated WC **1400** broken up into a grid or array of welding elements (i.e., wexels) forming a wexel map **1420**. Each wexel (e.g., wexel **1421**) defines a small portion of the surface **1410** of the welding coupon. The wexel map defines the surface resolution. Changeable channel parameter values are assigned to each wexel, allowing values of each wexel to dynamically change in real-time in virtual reality weld space during a simulated welding process. The changeable channel parameter values correspond to the channels Puddle (molten metal fluidity/viscosity displacement), Heat (heat absorption/dissipation), Displacement (solid displacement), and Extra (various extra states, e.g., slag, grain, scorching, virgin metal). These changeable channels are referred to herein as PHED for Puddle, Heat, Extra, and Displacement, respectively.

**[0080]** FIG. **15** illustrates an example embodiment of a coupon space and a weld space of the flat welding coupon (WC) **1400** of FIG. **14** simulated in the system **100** of FIG. **1**. Points O, X, Y, and Z define the local 3D coupon space. In general, each coupon type defines the mapping from 3D coupon space to 2D virtual reality weld space. The wexel map **1420** of FIG. **14** is a two-dimensional array of values that map to weld space in virtual reality. A user is to weld from point B to point E as shown in FIG. **15**. A trajectory line from point B to point E is shown in both 3D coupon space and 2D weld space in FIG. **15**.

**[0081]** Each type of coupon defines the direction of displacement for each location in the wexel map. For the flat welding coupon of FIG. **15**, the direction of displacement is the same at all locations in the wexel map (i.e., in the Z-direction). The texture coordinates of the wexel map are shown as S, T (sometimes called U, V) in both 3D coupon space and 2D weld space, in order to clarify the mapping. The wexel map is mapped to and represents the rectangular surface **1410** of the welding coupon **1400**.

**[0082]** FIG. **16** illustrates an example embodiment of a coupon space and a weld space of a corner (tee joint) welding coupon (WC) **1600** simulated in the system **100** of FIG. **1**. The corner WC **1600** has two surfaces **1610** and **1620** in 3D coupon space that are mapped to 2D weld space as shown in FIG. **16**. Again, points O, X, Y, and Z define the local 3D coupon space. The texture coordinates of the wexel map are shown as S, T in both 3D coupon space and 2D weld space, in order to clarify the mapping. A user is to weld from point B to point E as shown in FIG. **16**. A trajectory line from point B to point E is shown in both 3D coupon space and 2D weld space in FIG. **16**. However, the direction of displacement is towards the line X'-O' as shown in the 3D coupon space, towards the opposite corner as shown in FIG. **16**.

**[0083]** FIG. **17** illustrates an example embodiment of a coupon space and a weld space of a pipe welding coupon (WC) **1700** simulated in the system **100** of FIG. **1**. The pipe WC **1700** has a curved surface **1710** in 3D coupon space that is mapped to 2D weld space as shown in FIG. **17**. Again, points O, X, Y, and Z define the local 3D coupon space. The texture coordinates of the wexel map are shown as S, T in both 3D coupon space and 2D weld space, in order to clarify the mapping. A user is to weld from point B to point E along a curved trajectory as shown in FIG. **17**. A trajectory curve and line from point B to point E is shown in 3D coupon space and 2D weld space, respectively, in FIG. **17**. The direction of displacement is away from the line Y-O (i.e., away from the center of the pipe). FIG. **18** illustrates an example embodiment of the pipe welding coupon (WC) **1700** of FIG. **17**. The pipe WC **1700** is made of a non-ferric, non-conductive plastic and simulates two pipe pieces **1701** and **1702** coming together to form a root joint **1703**. An attachment piece **1704** for attaching to the arm **173** of the T/S **170** is also shown.

**[0084]** In a similar manner that a texture map may be mapped to a rectangular surface area of a geometry, a weldable wexel map may be mapped to a rectangular surface of a welding coupon. Each element of the weldable map is termed a wexel in the same sense that each element of a picture is termed a pixel (a contraction of picture element). A pixel contains channels of information that define a color (e.g., red, green, blue, etc.). A wexel contains channels of information (e.g., P, H, E, D) that define a weldable surface in virtual reality space.

[0085] In accordance with an embodiment of the present invention, the format of a wexel is summarized as channels PHED (Puddle, Heat, Extra, Displacement) which contains four floating point numbers. The Extra channel is treated as a set of bits which store logical information about the wexel such as, for example, whether or not there is any slag at the wexel location. The Puddle channel stores a displacement value for any liquefied metal at the wexel location. The Displacement channel stores a displacement value for the solidified metal at the wexel location. The Heat channel stores a value giving the magnitude of heat at the wexel location. In this way, the weldable part of the coupon can show displacement due to a welded bead, a shimmering surface “puddle” due to liquid metal, color due to heat, etc. All of these effects are achieved by the vertex and pixel shaders applied to the weldable surface. In accordance with an alternative embodiment of the present invention, a wexel may also incorporate specific metallurgical properties that may change during a welding simulation, for example, due to heat input to the wexel. Such metallurgical properties may be used to simulate virtual testing and inspection of a weldment.

[0086] In accordance with an embodiment of the present invention, a displacement map and a particle system are used where the particles can interact with each other and collide with the displacement map. The particles are virtual dynamic fluid particles and provide the liquid behavior of the weld puddle but are not rendered directly (i.e., are not visually seen directly). Instead, only the particle effects on the displacement map are visually seen. Heat input to a wexel affects the movement of nearby particles. There are two types of displacement involved in simulating a welding puddle which include Puddle and Displacement. Puddle is “temporary” and only lasts as long as there are particles and heat present. Displacement is “permanent”. Puddle displacement is the liquid metal of the weld which changes rapidly (e.g., shimmers) and can be thought of as being “on top” of the Displacement. The particles overlay a portion of a virtual surface displacement map (i.e., a wexel map). The Displacement represents the permanent solid metal including both the initial base metal and the weld bead that has solidified.

[0087] In accordance with an embodiment of the present invention, the simulated welding process in virtual reality space works as follows: Particles stream from the emitter (emitter of the simulated MWT 160) in a thin cone. The particles make first contact with the surface of the simulated welding coupon where the surface is defined by a wexel map. The particles interact with each other and the wexel map and build up in real-time. More heat is added the nearer a wexel is to the emitter. Heat is modeled in dependence on distance from the arc point and the amount of time that heat is input from the arc. Certain visuals (e.g., color, etc.) are driven by the heat. A weld puddle is drawn or rendered in virtual reality space for wexels having enough heat. Wherever it is hot enough, the wexel map liquefies, causing the Puddle displacement to “raise up” for those wexel locations. Puddle displacement is determined by sampling the “highest” particles at each wexel location. As the emitter moves on along the weld trajectory, the wexel locations left behind cool. Heat is removed from a wexel location at a particular rate. When a cooling threshold is reached, the wexel map solidifies. As such, the Puddle displacement is gradually converted to Displacement (i.e., a solidified bead). Displacement added is equivalent to Puddle removed such that the

overall height does not change. Particle lifetimes are tweaked or adjusted to persist until solidification is complete. Certain particle properties that are modeled in the system 100 include attraction/repulsion, velocity (related to heat), dampening (related to heat dissipation), direction (related to gravity).

[0088] FIGS. 19A-19C illustrate an example embodiment of the concept of a dual-displacement (displacement and particles) puddle model of the system 100 of FIG. 1. Welding coupons are simulated in virtual reality space having at least one surface. The surfaces of the welding coupon are simulated in virtual reality space as a double displacement layer including a solid displacement layer and a puddle displacement layer. The puddle displacement layer is capable of modifying the solid displacement layer.

[0089] As described herein, “puddle” is defined by an area of the wexel map where the Puddle value has been raised up by the presence of particles. The sampling process is represented in FIGS. 19A-19C. A section of a wexel map is shown having seven adjacent wexels. The current Displacement values are represented by un-shaded rectangular bars 1910 of a given height (i.e., a given displacement for each wexel). In FIG. 19A, the particles 1920 are shown as round un-shaded dots colliding with the current Displacement levels and are piled up. In FIG. 19B, the “highest” particle heights 1930 are sampled at each wexel location. In FIG. 19C, the shaded rectangles 1940 show how much Puddle has been added on top of the Displacement as a result of the particles. The weld puddle height is not instantly set to the sampled values since Puddle is added at a particular liquification rate based on Heat. Although not shown in FIGS. 19A-19C, it is possible to visualize the solidification process as the Puddle (shaded rectangles) gradually shrink and the Displacement (un-shaded rectangles) gradually grow from below to exactly take the place of the Puddle. In this manner, real-time molten metal fluidity characteristics are accurately simulated. As a user practices a particular welding process, the user is able to observe the molten metal fluidity characteristics and the heat dissipation characteristics of the weld puddle in real-time in virtual reality space and use this information to adjust or maintain his welding technique.

[0090] The number of wexels representing the surface of a welding coupon is fixed. Furthermore, the puddle particles that are generated by the simulation to model fluidity are temporary, as described herein. Therefore, once an initial puddle is generated in virtual reality space during a simulated welding process using the system 100, the number of wexels plus puddle particles tends to remain relatively constant. This is because the number of wexels that are being processed is fixed and the number of puddle particles that exist and are being processed during the welding process tend to remain relatively constant because puddle particles are being created and “destroyed” at a similar rate (i.e., the puddle particles are temporary). Therefore, the processing load of the PPS 110 remains relatively constant during a simulated welding session.

[0091] In accordance with an alternate embodiment of the present invention, puddle particles may be generated within or below the surface of the welding coupon. In such an embodiment, displacement may be modeled as being positive or negative with respect to the original surface displacement of a virgin (i.e., un-welded) coupon. In this manner, puddle particles may not only build up on the surface of a welding coupon, but may also penetrate the welding coupon.

However, the number of wexels is still fixed and the puddle particles being created and destroyed is still relatively constant.

**[0092]** In accordance with alternate embodiments of the present invention, instead of modeling particles, a wexel displacement map may be provided having more channels to model the fluidity of the puddle. Or, instead of modeling particles, a dense voxel map may be modeled. Or, instead of a wexel map, only particles may be modeled which are sampled and never go away. Such alternative embodiments may not provide a relatively constant processing load for the system, however.

**[0093]** Furthermore, in accordance with an embodiment of the present invention, blowthrough or a keyhole is simulated by taking material away. For example, if a user keeps an arc in the same location for too long, in the real world, the material would burn away causing a hole. Such real-world burnthrough is simulated in the system **100** by wexel decimation techniques. If the amount of heat absorbed by a wexel is determined to be too high by the system **100**, that wexel may be flagged or designated as being burned away and rendered as such (e.g., rendered as a hole). Subsequently, however, wexel re-constitution may occur for certain welding process (e.g., pipe welding) where material is added back after being initially burned away. In general, the system **100** simulates wexel decimation (taking material away) and wexel reconstitution (i.e., adding material back). Furthermore, removing material in root-pass welding is properly simulated in the system **100**.

**[0094]** Furthermore, removing material in root-pass welding is properly simulated in the system **100**. For example, in the real world, grinding of the root pass may be performed prior to subsequent welding passes. Similarly, system **100** may simulate a grinding pass that removes material from the virtual weld joint. It will be appreciated that the material removed may be modeled as a negative displacement on the wexel map. That is to say that the grinding pass removes material that is modeled by the system **100** resulting in an altered bead contour. Simulation of the grinding pass may be automatic, which is to say that the system **100** removes a predetermined thickness of material, which may be respective to the surface of the root pass weld bead.

**[0095]** In an alternative embodiment, an actual grinding tool, or grinder, may be simulated that turns on and off by activation of the mock welding tool **160** or another input device. It is noted that the grinding tool may be simulated to resemble a real world grinder. In this embodiment, the user maneuvers the grinding tool along the root pass to remove material responsive to the movement thereof. It will be understood that the user may be allowed to remove too much material. In a manner similar to that described above, holes or other defects (described above) may result if the user grinds away too much material. Still, hard limits or stops may be implemented, i.e. programmed, to prevent the user from removing too much material or indicate when too much material is being removed.

**[0096]** In addition to the non-visible “puddle” particles described herein, the system **100** also uses three other types of visible particles to represent Arc, Flame, and Spark effects, in accordance with an embodiment of the present invention. These types of particles do not interact with other particles of any type but interact only with the displacement map. While these particles do collide with the simulated weld surface, they do not interact with each other. Only

Puddle particles interact with each other, in accordance with an embodiment of the present invention. The physics of the Spark particles is setup such that the Spark particles bounce around and are rendered as glowing dots in virtual reality space.

**[0097]** The physics of the Arc particles is setup such that the Arc particles hit the surface of the simulated coupon or weld bead and stay for a while. The Arc particles are rendered as larger dim bluish-white spots in virtual reality space. It takes many such spots superimposed to form any sort of visual image. The end result is a white glowing nimbus with blue edges.

**[0098]** The physics of the Flame particles is modeled to slowly raise upward. The Flame particles are rendered as medium sized dim red-yellow spots. It takes many such spots superimposed to form any sort of visual image. The end result is blobs of orange-red flames with red edges raising upward and fading out. Other types of non-puddle particles may be implemented in the system **100**, in accordance with other embodiments of the present invention. For example, smoke particles may be modeled and simulated in a similar manner to flame particles.

**[0099]** The final steps in the simulated visualization are handled by the vertex and pixel shaders provided by the shaders **117** of the GPUs **115** (see FIG. **11**). The vertex and pixel shaders apply Puddle and Displacement, as well as surface colors and reflectivity altered due to heat, etc. The Extra (E) channel of the PHED wexel format, as discussed earlier herein, contains all of the extra information used per wexel. In accordance with an embodiment of the present invention, the extra information includes a non virgin bit (true=bead, false=virgin steel), a slag bit, an undercut value (amount of undercut at this wexel where zero equals no undercut), a porosity value (amount of porosity at this wexel where zero equals no porosity), and a bead wake value which encodes the time at which the bead solidifies. There are a set of image maps associated with different coupon visuals including virgin steel, slag, bead, and porosity. These image maps are used both for bump mapping and texture mapping. The amount of blending of these image maps is controlled by the various flags and values described herein.

**[0100]** A bead wake effect is achieved using a 1D image map and a per wexel bead wake value that encodes the time at which a given bit of bead is solidified. Once a hot puddle wexel location is no longer hot enough to be called “puddle”, a time is saved at that location and is called “bead wake”. The end result is that the shader code is able to use the 1D texture map to draw the “ripples” that give a bead its unique appearance which portrays the direction in which the bead was laid down. In accordance with an alternative embodiment of the present invention, the system **100** is capable of simulating, in virtual reality space, and displaying a weld bead having a real-time weld bead wake characteristic resulting from a real-time fluidity-to-solidification transition of the simulated weld puddle, as the simulated weld puddle is moved along a weld trajectory.

**[0101]** In accordance with an alternative embodiment of the present invention, the system **100** is capable of teaching a user how to troubleshoot a welding machine. For example, a troubleshooting mode of the system may train a user to make sure he sets up the system correctly (e.g., correct gas flow rate, correct power cord connected, etc.) In accordance with another alternate embodiment of the present invention, the system **100** is capable of recording and playing back a

welding session (or at least a portion of a welding session, for example, N frames). A track ball may be provided to scroll through frames of video, allowing a user or instructor to critique a welding session. Playback may be provided at selectable speeds as well (e.g., full speed, half speed, quarter speed). In accordance with an embodiment of the present invention, a split-screen playback may be provided, allowing two welding sessions to be viewed side-by-side, for example, on the ODD 150. For example, a “good” welding session may be viewed next to a “poor” welding session for comparison purposes.

#### Virtual Testing and Inspection

**[0102]** An embodiment of the present invention comprises a system for the virtual testing and inspecting of a virtual weldment. The system includes a programmable processor-based subsystem operable to execute coded instructions. The coded instructions include a rendering engine and an analysis engine. The rendering engine is configured to render at least one of a three-dimensional (3D) virtual weldment before simulated testing, a 3D animation of a virtual weldment under simulated testing, and a 3D virtual weldment after simulated testing. The analysis engine is configured to perform simulated testing of a 3D virtual weldment. The simulated testing may include at least one of simulated destructive testing and simulated non-destructive testing. The analysis engine is further configured to perform inspection of at least one of a 3D virtual weldment before simulated testing, a 3D animation of a virtual weldment under simulated testing, and a 3D virtual weldment after simulated testing for at least one of pass/fail conditions and defect/discontinuity characteristics. The system also includes at least one display device operatively connected to the programmable processor-based subsystem for displaying at least one of a 3D virtual weldment before simulated testing, a 3D animation of a virtual weldment under simulated testing, and a 3D virtual weldment after simulated testing. The system further includes a user interface operatively connected to the programmable processor-based subsystem and configured for at least manipulating an orientation of at least one of a 3D virtual weldment before simulated testing, a 3D animation of a virtual weldment under simulated testing, and a 3D virtual weldment after simulated testing on the at least one display device. The programmable processor-based subsystem may include a central processing unit and at least one graphics processing unit. The at least one graphics processing unit may include a computer unified device architecture (CUDA) and a shader. The analysis engine may include at least one of an expert system, a support vector machine (SVM), a neural network, and one or more intelligent agents. The analysis engine may use welding code data or welding standards data to analyze at least one of a 3D virtual weldment before simulated testing, a 3D animation of a virtual weldment under simulated testing, and a 3D virtual weldment after simulated testing. The analysis engine may also include programmed virtual inspection tools that can be accessed and manipulated by a user using the user interface to inspect a virtual weldment.

**[0103]** Another embodiment of the present invention comprises a virtual welding testing and inspecting simulator. The simulator includes means for performing one or more simulated destructive and non-destructive tests on a rendered 3D virtual weldment. The simulator also includes means for analyzing results of the one or more simulated destructive

and non-destructive tests on the rendered 3D virtual weldment. The simulator further includes means for inspecting the rendered 3D virtual weldment at least after a simulated test of the 3D virtual weldment. The simulator may also include means for rendering a 3D virtual weldment. The simulator may further include means for rendering a 3D animation of the virtual weldment while performing the one or more simulated destructive and non-destructive tests. The simulator may also include means for displaying and manipulating an orientation of the 3D animation of the virtual weldment. The simulator may further include means for inspecting a 3D virtual weldment before, during, and after simulated testing of the 3D virtual weldment.

**[0104]** A further embodiment of the present invention comprises a method of assessing the quality of a rendered baseline virtual weldment in virtual reality space. The method includes subjecting the baseline virtual weldment to a first computer-simulated test configured to test at least one characteristic of the baseline virtual weldment. The method also includes rendering a first tested virtual weldment and generating first test data in response to the first test. The method further includes subjecting the first tested virtual weldment and the first test data to a computer-simulated analysis configured to determine at least one pass/fail condition of the first tested virtual weldment with respect to the at least one characteristic. The first computer-simulated test may simulate a real-world destructive test or a real-world non-destructive test. The method may further include re-rendering the baseline virtual weldment in virtual reality space, subjecting the baseline virtual weldment to a second computer-simulated test configured to test at least one other characteristic of the baseline virtual weldment, rendering a second tested virtual weldment and generating second test data in response to the second test, and subjecting the second tested virtual weldment and the second test data to a computer-simulated analysis configured to determine at least one other pass/fail condition of the second tested virtual weldment with respect to the at least one other characteristic. The second computer-simulated test may simulate a real-world destructive test or a real-world non-destructive test. The method may further include manually inspecting a displayed version of the rendered first tested virtual weldment. The method may also include manually inspecting a displayed version of the rendered second tested virtual weldment.

**[0105]** A completed virtual weldment formed in virtual reality space may be analyzed for weld defects and a determination may be made as to whether or not such a weldment would pass or fail standard industry tests, in accordance with an embodiment of the present invention. Certain defects may cause certain types of failures within certain locations within the weldment. The data representing any defects or discontinuities is captured as part of the definition of the virtual weldment either by pre-defining the virtual weldment or by creating a virtual weldment using a virtual reality welding simulator system (e.g., a virtual reality arc welding (VRAW) system) as part of a virtual welding process.

**[0106]** Also, criterion for pass/fail of any particular test is known a priori based on predefined welding codes and standards such as, for example, the AWS welding standards. In accordance with an embodiment of the present invention, an animation is created allowing visualization of a simulated destructive or non-destructive test of the virtual weldment. The same virtual weldment can be tested many different



ways. Testing and inspection of a virtual weldment may occur on a virtual reality welding simulator system (e.g., a virtual reality arc welding (VRAW) system) which is described in detail later herein. Inspection of a virtual weldment may occur on a standalone virtual weldment inspection (VWI) system which is described in detail later herein.

**[0107]** The VRAW system is capable of allowing a user to create a virtual weldment in real time by simulating a welding scenario as if the user is actually welding, and capturing all of the resultant data which defines the virtual weldment, including defects and discontinuities. The VRAW system is further capable of performing virtual destructive and non-destructive testing and inspection of the virtual weldment as well as materials testing and inspection of the virtual weldment. The standalone VWI system is capable of inputting a predefined virtual weldment or a virtual weldment created using the VRAW system, and performing virtual inspection of the virtual weldment. A three-dimensional virtual weldment or part may be derived from a computer-aided design (CAD) model, in accordance with an embodiment of the present invention. Therefore, testing and inspection may be simulated on irregular geometries for specific parts. In accordance with an embodiment of the present application, the VRAW system is also capable of performing virtual inspection of a predefined virtual weldment. For example, the VRAW system may include pre-made virtual weldments which a student may refer to in order to learn how a good weld should look.

**[0108]** Various types of welding discontinuities and defects include improper weld size, poor bead placement, concave bead, excessive convexity, undercut, porosity, incomplete fusion, slag inclusion, excess spatter, overflow, cracks, and burnthrough or melt through which are all well known in the art. For example, undercut is often due to an incorrect angle of welding. Porosity is cavity type discontinuities formed by gas entrapment during solidification, often caused by moving the arc too far away from the weldment. Other problems may occur due to an incorrect process, fill material, wire size, or technique, all of which may be simulated.

**[0109]** Various types of destructive tests that may be performed include a root bend test, a face bend test, a side bend test, a tensile or pull test, a break test (e.g., a nick break test or a T-joint break test), an impact test, and a hardness test which are all well known in the art. For many of these tests, a piece is cut out of the weldment and the test is performed on that piece. For example, a root bend test is a test that bends the cut piece from the weldment such that the weld root is on the convex surface of a specified bend radius. A side bend test is a test that bends the weldment such that the side of a transverse section of the weld is on the convex surface of a specified bend radius. A face bend test is a test that bends the weldment such that the weld face is on the convex surface of a specified bend radius.

**[0110]** A further destructive test is a tensile or pull test where a cut piece from a weldment is pulled or stretched until the weld breaks, testing the elastic limit and tensile strength of the weld. Another destructive test is a break test. One type of break test is a test on a weldment having two sections welded together at 90 degrees to each other to form a T-joint, where one section is bent over toward the other section to determine if the weld breaks or not. If the weld breaks, the internal weld bead can be inspected. An impact

test is a test where an impacting element is forced into a weldment at various temperatures to determine the ability of the weldment to resist impact. A weldment may have good strength under static loading, yet may fracture if subjected to a high-velocity impact. For example, a pendulum device may be used to swing down and hit a weldment (possibly breaking the weldment) and is called a Charpy impact test.

**[0111]** A further destructive test is a hardness test which tests a weldments ability to resist indentation or penetration at the weld joint. The hardness of a weldment depends on the resultant metallurgical properties at the weld joint which is based, in part, on how the weld joint cools in the heat-affected zone. Two types of hardness tests are the Brinell test and the Rockwell tests. Both tests use a penetrator with either a hard sphere or a sharp diamond point. The penetrator is applied to the weld under a standardized load. When the load is removed, the penetration is measured. The test may be performed at several points in the surrounding metal and is a good indicator of potential cracking. A further type of destructive test is a bend-on-pipe test where a welded pipe is cut to take a piece out of each of the four quadrants of the pipe. A root bend is performed on two of the pieces and a face bend is performed on the other two pieces.

**[0112]** Various types of non-destructive tests that may be performed include radiographic tests and ultrasonic tests. In a radiographic test, the weldment is exposed to X-rays and an X-ray image of the weld joint is generated which can be examined. In an ultrasonic test, the weldment is exposed to ultrasonic energy and various properties of the weld joint are derived from the reflected ultrasonic waves. For certain types of non-destructive testing, the weldment is subjected (in a virtual manner) to X-ray or ultrasound exposure and defects such as internal porosity, slag entrapment, and lack of penetration are visually presented to the user. Another type of non-destructive testing is dye penetrant or liquid penetrant testing which may be simulated in a virtual reality manner. A weldment is subjected to a dye material and the weldment is then exposed to a developer to determine, for example, if surface cracks exist that are not visible to the naked eye. A further non-destructive testing is magnetic particle testing that is also used for detecting cracks and may be simulated in a virtual reality manner. Small cracks below the surface of a weldment can be created by improper heat input to the weldment. In accordance with an embodiment of the present invention, travel speed and other welding process parameters are tracked in the virtual reality environment and used to determine heat input to the weldment and, therefore, cracks near the surface of the weldment which may be detected using virtual non-destructive testing.

**[0113]** Furthermore, simulation of a weldment in a simulated structure may be performed. For example, a virtual weldment having a virtual weld joint created by a user of a VRAW system may be incorporated into a virtual simulation of a bridge for testing. The virtual weldment may correspond to a key structural element of the bridge, for example. The bridge may be specified to last one-hundred years before failing. The test may involve observing the bridge over time (i.e., virtual time) to see if the weldment fails. For example, if the weldment is of poor quality (i.e., has unacceptable discontinuities or defects), the simulation may show an animation of the bridge collapsing after 45 years.

**[0114]** FIGS. 1-19C disclose an embodiment of a virtual reality arc welding (VRAW) system 100 capable of simulating, in virtual reality space, a real time welding scenario

including formation of a virtual weldment by a user (welder) and various defect and discontinuity characteristics associated with the weldment, as well as simulating testing and inspection of the virtual weldment and displaying an animation of the virtual weldment under test to observe the effects. The VRAW system is capable of creating a sophisticated virtual rendering of a weldment and performing a sophisticated analysis of the virtual rendering that compares various characteristics of the virtual weldment to a welding code.

**[0115]** Virtual inspection may be implemented on the VRAW system in any of a number of different ways and/or combinations thereof. In accordance with one embodiment of the present invention, the VRAW system includes an expert system and is driven by a set of rules. An expert system is software that attempts to provide an answer to a problem, or clarify uncertainties where normally one or more human experts would need to be consulted. Expert systems are most common in a specific problem domain, and is a traditional application and/or subfield of artificial intelligence. A wide variety of methods can be used to simulate the performance of the expert, however, common to many are 1) the creation of a knowledge base which uses some knowledge representation formalism to capture the Subject Matter Expert's (SME) knowledge (e.g., a certified welding inspector's knowledge) and 2) a process of gathering that knowledge from the SME and codifying it according to the formalism, which is called knowledge engineering. Expert systems may or may not have learning components but a third common element is that, once the system is developed, it is proven by being placed in the same real world problem solving situation as the human SME, typically as an aid to human workers or a supplement to some information system.

**[0116]** In accordance with another embodiment of the present invention, the VRAW system includes support vector machines. Support vector machines (SVMs) are a set of related supervised learning methods used for classification and regression. Given a set of training examples, each marked as belonging to one of two categories, a SVM training algorithm builds a model that predicts whether a new example falls into one category or the other (e.g., pass/fail categories for particular defects and discontinuities). Intuitively, an SVM model is a representation of the examples as points in space, mapped so that the examples of the separate categories are divided by a clear gap that is as wide as possible. New examples are then mapped into that same space and predicted to belong to a category based on which side of the gap they fall on.

**[0117]** In accordance with still a further embodiment of the present invention, the VRAW system includes a neural network that is capable of being trained and adapted to new scenarios. A neural network is made up of interconnecting artificial neurons (programming constructs that mimic the properties of biological neurons). Neural networks may either be used to gain an understanding of biological neural networks, or for solving artificial intelligence problems without necessarily creating a model of a real biological system. In accordance with an embodiment of the present invention, a neural network is devised that inputs defect and discontinuity data from virtual weldment data, and outputs pass/fail data.

**[0118]** In accordance with various embodiments of the present invention, intelligent agents may be employed to

provide feedback to a student concerning areas where the student needs more practice, or to provide feedback to an instructor or educator as to how to modify the teaching curriculum to improve student learning. In artificial intelligence, an intelligent agent is an autonomous entity, usually implemented in software, which observes and acts upon an environment and directs its activity towards achieving goals. An intelligent agent may be able to learn and use knowledge to achieve a goal (e.g., the goal of providing relevant feedback to a welding student or a welding educator).

**[0119]** In accordance with an embodiment of the present invention, a virtual rendering of a weldment created using the VRAW system is exported to a destructive/non-destructive testing portion of the system. The testing portion of the system is capable of automatically generating cut sections of the virtual weldment (for destructive testing) and submitting those cut sections to one of a plurality of possible tests within the testing portion of the VRAW system. Each of the plurality of tests is capable of generating an animation illustrating that particular test. The VRAW system is capable of displaying the animation of the test to the user. The animation clearly shows to the user whether or not the virtual weldment generated by the user passes the test. For non-destructive testing, the weldment is subjected (in a virtual manner) to X-ray or ultrasound exposure and defects such as internal porosity, slag entrapment, and lack of penetration are visually presented to the user.

**[0120]** For example, a virtual weldment that is subjected to a virtual bend test may be shown to break in the animation at a location where a particular type of defect occurs in the weld joint of the virtual weldment. As another example, a virtual weldment that is subjected to a virtual bend test may be shown to bend in the animation and crack or show a significant amount of defect, even though the weldment does not completely break. The same virtual weldment may be tested over and over again for different tests using the same cut sections (e.g., the cut sections may be reconstituted or re-rendered by the VRAW system) or different cut sections of the virtual weldment. In accordance with an embodiment of the present invention, a virtual weldment is tagged with metallurgical characteristics such as, for example, type of metal and tensile strength which are factored into the particular selected destructive/non-destructive test. Various common base welding metals are simulated, including welding metals such as aluminum and stainless, in accordance with various embodiments of the present invention.

**[0121]** In accordance with an embodiment of the present invention, a background running expert system may pop up in a window on a display of the VRAW system and indicate to the user (e.g., via a text message and/or graphically) why the weldment failed the test (e.g., too much porosity at these particular points in the weld joint) and what particular welding standard(s) was not met. In accordance with another embodiment of the present invention, the VRAW system may hyper-text link to an external tool that ties the present test to a particular welding standard. Furthermore, a user may have access to a knowledge base including text, pictures, video, and diagrams to support their training.

**[0122]** In accordance with an embodiment of the present invention, the animation of a particular destructive/non-destructive test is a 3D rendering of the virtual weldment as modified by the test such that a user may move the rendered virtual weldment around in a three-dimensional manner on a display of the VRAW system during the test to view the

test from various angles and perspectives. The same 3D rendered animation of a particular test may be played over and over again to allow for maximum training benefit for the same user or for multiple users.

**[0123]** In accordance with an embodiment of the present invention, the rendered virtual weldment and/or the corresponding 3D rendered animation of the virtual weldment under test may be exported to an inspection portion of the system to perform an inspection of the weld and/or to train a user in welding inspection (e.g., for becoming a certified welding inspector). The inspection portion of the system includes a teaching mode and a training mode.

**[0124]** In the teaching mode, the virtual weldment and/or the 3D rendered animation of a virtual weldment under test is displayed and viewed by a grader (trainer) along with a welding student. The trainer and the welding student are able to view and interact with the virtual weldment. The trainer is able to make a determination (e.g., via a scoring method) how well the welding student performed at identifying defects and discontinuities in the virtual weldment, and indicate to the welding student how well the welding student performed and what the student missed by interacting with the displayed virtual weldment (viewing from different perspectives, etc.).

**[0125]** In the training mode, the system asks a welding inspector student various questions about the virtual weldment and allows the welding inspector student to input answers to the questions. The system may provide the welding inspector student with a grade at the end of the questioning. For example, the system may initially provide sample questions to the welding inspector student for one virtual weldment and then proceed to provide timed questions to the welding inspector student for another virtual weldment which is to be graded during a testing mode.

**[0126]** The inspection portion of the system may also provide certain interactive tools that help a welding inspector student or trainer to detect defects and make certain measurements on the virtual weld which are compared to predefined welding standards (e.g., a virtual gauge that measures penetration of a root weld and compares the measurement to a required standard penetration). Grading of a welding inspector student may also include whether or not the welding inspector student uses the correct interactive tools to evaluate the weld. In accordance with an embodiment of the present invention, the inspection portion of the system, based on grading (i.e., scoring) determines which areas the welding inspector student needs help and provides the welding inspector student with more representative samples upon which to practice inspecting.

**[0127]** As discussed previously herein, intelligent agents may be employed to provide feedback to a student concerning areas where the student needs more practice, or to provide feedback to an instructor or educator as to how to modify the teaching curriculum to improve student learning. In artificial intelligence, an intelligent agent is an autonomous entity, usually implemented in software, which observes and acts upon an environment and directs its activity towards achieving goals. An intelligent agent may be able to learn and use knowledge to achieve a goal (e.g., the goal of providing relevant feedback to a welding student or a welding educator). In accordance with an embodiment of the present invention, the environment perceived and acted upon by an intelligent agent is the virtual reality environment generated by the VRAW system, for example.

**[0128]** Again, the various interactive inspection tools may be used on either the virtual weldment before being subjected to testing, the virtual weldment after being subjected to testing, or both. The various interactive inspection tools and methodologies are configured for various welding processes, types of metals, and types of welding standards, in accordance with an embodiment of the present invention. On the standalone VWI system, the interactive inspection tools may be manipulated using a keyboard and mouse, for example. On the VRAW system, the interactive inspection tools may be manipulated via a joystick and/or a console panel, for example.

**[0129]** As discussed earlier herein, a standalone virtual weldment inspection (VWI) system is capable of inputting a predefined virtual weldment or a virtual weldment created using the VRAW system, and performing virtual inspection of the virtual weldment. However, unlike the VRAW system, the VWI system may not be capable of creating a virtual weldment as part of a simulated virtual welding process, and may or may not be capable of performing virtual destructive/non-destructive testing of that weldment, in accordance with certain embodiments of the present invention.

**[0130]** FIG. 20 illustrates an example embodiment of a standalone virtual weldment inspection (VWI) system 2000 capable of simulating inspection of a virtual weldment and displaying an animation of the virtual weldment under inspection to observe the effects due to various characteristics associated with the weldment. In one embodiment the VWI system 2000 includes a programmable processor-based subsystem (PPS) 2010, similar to the PPS 110 of FIG. 1. The VWI system 2000 further includes an observer display device (ODD) 2050, similar to the ODD 150 of FIG. 1, operatively connected to the PPS 2010. The VWI system 2000 also includes a keyboard 2020 and a mouse 2030 operatively connected to the PPS 2010.

**[0131]** In a first embodiment of the system 2000 of FIG. 20, the PPS 110 provides hardware and software configured as a rendering engine for providing 3D animated renderings of virtual weldments. The PPS 110 also provides hardware and software configured as an analysis engine for performing testing and inspection of a virtual weldment. The PPS 2010 is capable of inputting data representative of a virtual weldment and generating an animated 3D rendering of the virtual weldment for inspection using a rendering engine of the PPS 110 operating on the input data. The virtual weldment data may be “pre-canned” (i.e. pre-defined) virtual weldments (e.g., generated using a separate computer system) or virtual weldment data created using a virtual reality welding simulator system (e.g., a VRAW system as previously described herein).

**[0132]** Furthermore, in accordance with an enhanced embodiment of the present invention, the PPS 2010 includes an advanced analysis/rendering/animation capability that allows the VWI system 2000 to perform a virtual destructive/non-destructive test on an input virtual weldment and display an animation of the test, similar to that of the VRAW system.

**[0133]** In accordance with an embodiment of the present invention, a virtual rendering of a weldment created using a VRAW system is exported to the VWI system. A testing portion of the VWI system is capable of automatically generating cut sections of the virtual weldment and submitting those cut sections (or the uncut virtual weldment itself)

to one of a plurality of possible destructive and non-destructive tests within the testing portion of the VWI system. Each of the plurality of tests is capable of generating an animation illustrating that particular test. The VWI system is capable of displaying the animation of the test to the user. The animation clearly shows to the user whether or not the virtual weldment generated by the user passes the test.

**[0134]** For example, a virtual weldment that is subjected to a virtual bend test may be shown to break in the animation at a location where a particular type of defect occurs in the weld joint of the virtual weldment. As another example, a virtual weldment that is subjected to a virtual bend test may be shown to bend in the animation and crack or show a significant amount of defect, even though the weldment does not completely break. The same virtual weldment may be tested over and over again for different tests using the same cut sections (e.g., the cut sections may be reconstituted by the VWI system) or different cut sections of the virtual weldment. In accordance with an embodiment of the present invention, a virtual weldment is tagged with metallurgical characteristics such as, for example, type of metal and tensile strength which are factored into the particular selected destructive/non-destructive test.

**[0135]** In accordance with an embodiment of the present invention, a background running expert system may pop up in a window on a display of the VWI system and indicate to the user (e.g., via a text message and/or graphically) why the weldment failed the test (e.g., too much porosity at these particular points in the weld joint) and what particular welding standard(s) was not met. In accordance with another embodiment of the present invention, the VWI system may hyper-text link to an external tool that ties the present test to a particular welding standard.

**[0136]** In accordance with an embodiment of the present invention, the animation of a particular destructive/non-destructive test is a 3D rendering of the virtual weldment as modified by the test such that a user may move the rendered virtual weldment around in a three-dimensional manner on a display of the VWI system during the test to view the test from various angles and perspectives. The same 3D rendered animation of a particular test may be played over and over again to allow for maximum training benefit for the same user or for multiple users.

**[0137]** In a simpler, less complex embodiment of the VWI system **2000** of FIG. 20, the PPS **2010** is capable of inputting an animated 3D rendering of a virtual destructive or non-destructive test generated by a VRAW system, and displaying the animation for inspection purposes. The PPS **2010** provides hardware and software configured as an analysis engine for performing inspection of a virtual weldment. However, in this simpler embodiment, the PPS **2010** does not provide hardware and software configured as a rendering engine for providing 3D animated renderings of virtual weldments, and the analysis engine is limited to supporting inspection of a virtual weldment. The renderings and testing are done elsewhere (e.g., on a VRAW system) and are input to the VWI system in such an embodiment. In such a simpler embodiment, the PPS **2010** may be a standard, off-the-shelf personal computer or work station programmed with software to perform virtual inspection and to train with respect to welding inspection.

**[0138]** As previously discussed herein, virtual inspection may be implemented on the VWI system in any of a number of different ways and/or combinations thereof. In accordance

with one embodiment of the present invention, the VWI system includes an expert system and is driven by a set of rules. In accordance with another embodiment of the present invention, the VWI system includes support vector machines. In accordance with still a further embodiment of the present invention, the VWI system includes a neural network that is capable of being trained and adapted to new scenarios, and/or intelligent agents that provide feedback to a student concerning areas where the student needs more practice, or to provide feedback to an instructor or educator as to how to modify the teaching curriculum to improve student learning. Furthermore, a user may have access to a knowledge base which includes text, pictures, video, and diagrams to support their training.

**[0139]** In accordance with an embodiment of the present invention, a rendered virtual weldment and/or a corresponding 3D rendered animation of the virtual weldment under test may be input to the VWI system to perform an inspection of the weld and/or to train a user in welding inspection (e.g., for becoming a certified welding inspector). The inspection portion of the system includes a teaching mode and a training mode.

**[0140]** In the teaching mode, the virtual weldment and/or the 3D rendered animation of a virtual weldment under test is displayed and viewed by a grader (trainer) along with a welding student. The trainer and the welding student are able to view and interact with the virtual weldment. The trainer is able to make a determination (e.g., via a scoring method) how well the welding student performed at identifying defects and discontinuities in the virtual weldment, and indicate to the welding student how well the welding student performed and what the student missed by interacting with the displayed virtual weldment (viewing from different perspectives, etc.).

**[0141]** In the training mode, the system asks a welding inspector student various questions about the virtual weldment and allows the welding inspector student to input answers to the questions. The system may provide the welding inspector student with a grade at the end of the questioning. For example, the system may initially provide sample questions to the welding inspector student for one virtual weldment and then proceed to provide timed questions to the welding inspector student for another virtual weldment which is to be graded.

**[0142]** The inspection portion of the system may also provide certain interactive tools that help a welding inspector student or trainer to detect defects and make certain measurements on the virtual weld which are compared to predefined welding standards (e.g., a virtual gauge that measures, for example, penetration of a root weld and compares the measurement to a required standard penetration). Grading of a welding inspector student may also include whether or not the welding inspector student uses the correct interactive tools to evaluate the weld. In accordance with an embodiment of the present invention, the inspection portion of the system, based on grading (i.e., scoring) determines which areas the welding inspector student needs help and provides the welding inspector student with more representative samples upon which to practice inspecting.

**[0143]** Again, the various interactive inspection tools may be used on either the virtual weldment before being subjected to testing, the virtual weldment after being subjected to testing, or both. The various interactive inspection tools

and methodologies are configured for various welding processes, types of metals, and types of welding standards, in accordance with an embodiment of the present invention. On the standalone VWI system **2000**, the interactive inspection tools may be manipulated using a keyboard **2020** and mouse **2030**, for example. Other examples of interactive inspection tools include a virtual Palmgren gauge for performing a throat measurement, a virtual fillet gauge for determining leg size, a virtual VWAC gauge for performing a convexity measurement or measurement of undercut, a virtual sliding caliper for measuring the length of a crack, a virtual micrometer for measuring the width of a crack, and a virtual magnifying lens for magnifying a portion of a weld for inspection. Other virtual interactive inspection tools are possible as well, in accordance with various embodiments of the present invention.

[0144] FIG. **21** illustrates a flow chart of an example embodiment of a method **2100** to assess the quality of a rendered baseline virtual weldment in virtual reality space. In step **2110**, a baseline virtual weldment is rendered (or rendered again . . . re-rendered). For example, a user may employ the VRAW system **100** to practice his welding technique on a virtual part and render the baseline virtual weldment, being representative of the user's welding ability. As used herein, the term "virtual weldment" may refer to the entire virtual welded part or a virtual cut section thereof, as is used in many welding tests.

[0145] In step **2120**, the baseline virtual weldment is subjected to a computer-simulated test (e.g., a destructive virtual test or a non-destructive virtual test) configured to test a characteristic(s) of the baseline virtual weldment. The computer-simulated test may be performed by the VRAW system or the VWI system, for example. In step **2130**, in response to the simulated testing, a tested virtual weldment is rendered (e.g., a modification of the baseline virtual weldment due to destructive testing) and associated test data is generated. In step **2140**, the tested virtual weldment and the test data is subjected to a computer-simulated analysis. The computer-simulated analysis is configured to determine pass/fail conditions of the tested virtual weldment with respect to the characteristic(s) of the virtual weldment. For example, a determination may be made as to whether or not the virtual weldment passed a bend test, based on analysis of the characteristic(s) after the test.

[0146] In step **2150**, a decision is made by the user to inspect the tested virtual weldment or not. If the decision is not to inspect then, in step **2160**, a decision is made as to performing another test or not. If the decision is made to perform another test, then the method reverts back to step **2110** and the baseline virtual weldment is re-rendered, as if the previous test did not take place on the virtual weldment. In this manner, many tests (destructive and non-destructive) can be run on the same baseline virtual weldment and analyzed for various pass/fail conditions. In step **2150**, if the decision is to inspect then, in step **2170**, the tested virtual weldment (i.e., the virtual weldment after testing) is displayed to the user and the user may manipulate the orientation of the tested virtual weldment to inspect various characteristics of the tested virtual weldment. In step **2180**, the user may access and apply programmed inspection tools to the tested virtual weldment to aid in the inspection. For example, a user may access a virtual gauge that measures penetration of a root weld and compares the measurement to a required standard penetration. After inspection, again in

step **2160**, the decision is made to perform another test or not. If another test is not to be performed, then the method ends.

[0147] As an example, a same cut section of a virtual weldment **2200** may be subjected to a simulated bend test, a simulated tensile or pull test, and a simulated nick break test as shown in FIGS. **22-24**, respectively. Referring to FIG. **22**, a straight cut section of a virtual weldment **2200** having a weld joint **2210** is subject to a simulated bend test. The bend test may be performed to find various weld properties such as ductility of the welded zone, weld penetration, fusion, crystalline structure (of the fractured surface), and strength. The bend test helps to determine the quality of the weld metal, the weld junction, and the heat affected zone. Any cracking of the metal during the bend test indicates poor fusion, poor penetration, or some other condition that can cause cracking. Stretching of the metal helps indicate the ductility of the weld. A fractured surface reveals the crystalline structure of the weld. Larger crystals tend to indicate a defective welding procedure or inadequate heat treatment after welding. A quality weld has small crystals.

[0148] Referring to FIG. **23**, after the bend test, the same straight cut section of the virtual weldment **2200** having the same weld joint **2210** may be re-rendered and subject to a simulated pull test. The pull test (or tensile test) may be performed to find the strength of a welded joint. In the simulated test, the virtual weldment **2200** is held on one end and pulled on the other end until the virtual weldment **2200** breaks. The tensile load or pull, at which the weldment **2200** breaks, is determined and may be compared to a standard measure for pass/fail determination.

[0149] Referring to FIG. **24**, after the pull test, the same straight cut section of the virtual weldment **2200** having the same weld joint **2210** may be re-rendered and subject to a simulated nick break test. The simulated nick break test is performed to determine if the weld metal of a welded butt joint has any internal defects such as, for example, slag inclusion, gas pockets, poor fusion, and oxidized metal. A slot is cut into each side of the weld joint **2210** as shown in FIG. **24**. The virtual weldment **2200** is positioned across two supports and struck with a hammer until the section of the weld **2210** between the slots fractures. The internal metal of the weld **2210** may be inspected for defects. Defects may be compared to standard measures for pass/fail determination.

#### Enhanced Education and Training

[0150] One embodiment provides a virtual reality arc welding system. The system includes a programmable processor-based subsystem, a spatial tracker operatively connected to the programmable processor-based subsystem, at least one mock welding tool configured to be spatially tracked by the spatial tracker, and at least one user interface configured to allow a user to perform one or more of inputting information into the system and making selections. The system further includes a communication component operatively connected to the programmable processor-based subsystem and configured to access an external communication infrastructure. Furthermore, the virtual reality welding system is configured to direct a user to one or more pre-identified web sites on the internet, in response to a user request, related to welding education and theory via the external communication infrastructure using the communication component. The user request may be prompted by one or more of the user, a human welding instructor, or an

intelligent agent configured on the programmable processor-based subsystem. The system may further include one or more audio transducer devices operatively connected to the programmable processor-based subsystem and configured to facilitate audio communication between a user and a welding instructor at a remote location via the external communication infrastructure using the communication component. The system may further include one or more video devices operatively connected to the programmable processor-based subsystem and configured to facilitate visual communication between a user and a welding instructor at a remote location via the external communication infrastructure using the communication component. The virtual reality welding system may be further configured to receive commands from a remote device at a remote location via the external communication infrastructure using the communication component, wherein the commands are configured to direct one or more of troubleshooting the virtual reality welding system or changing settings of the virtual reality welding system. The remote device may include, for example, one of a hand-held mobile device, a desk top personal computer device, or a server computer operated by a remote user. The external communication infrastructure may include, for example, one or more of the internet, a cellular telephone network, or a satellite communication network.

[0151] FIG. 25 illustrates a second example embodiment of a system block diagram of a system 2500 providing arc welding training in a real-time virtual reality environment. The system 2500 is similar to the system 100 of FIG. 1. However, the system 2500 of FIG. 25 illustrates additional elements including a communication component (CC) 2510, audio transducers 2520 (e.g., a speaker) and 2530 (e.g., a microphone), a video device 2540 (e.g., a camera), and an intelligent agent 2550.

[0152] The CC 2510 may be, for example, one or more of a cable modem, a wireless router, or a 3G or 4G cellular communication module, providing access and connection to an external communication infrastructure (e.g., the internet). In accordance with an embodiment, the CC 2510 also provides a web browser to aid in facilitating accessing of web sites on the internet. FIG. 26 illustrates a system block diagram showing how the virtual reality arc welding system 2500 of FIG. 25 may interface to a remote device 2610 via an external communication infrastructure 2600. The remote device 2610 is operated by a remote user and may be, for example, a wireless mobile device, a desktop personal computer, or a server computer.

[0153] When a user of the virtual reality welding system (e.g., a welding student) is performing a simulated welding procedure, the user may experience difficulty or become confused about some aspect of performing the welding procedure properly. In accordance with an embodiment, the user may, via a user interface (e.g., the WUI 130 or the ODD 150) request to be directed to one of a plurality of pre-identified web sites on the internet related to welding education and theory.

[0154] The system 2500 can automatically access the selected web site using the CC 2510 and display a corresponding main web page to the user on, for example, the ODD 150 or the FMDD 140. Once at the main web page, the user can select other web pages associated with the web site via the user interface. In accordance with an embodiment, the identified web sites and associated web pages are specifically designed to deal with common problems experi-

enced by welding students (e.g., orientation of a welding tool, electrode-to-workpiece distance, welding tool travel speed, etc.). In this manner, a user may quickly and easily find answers to alleviate his difficulty or confusion with respect to the present simulated welding procedure.

[0155] As an alternative, a welding instructor observing the user may see that the user is having some particular difficulty or problem and, as a result, may request that the user be directed to one of the plurality of pre-identified web sites. As a further alternative, an intelligent agent (IA) 2550 configured on the PPS 110 may automatically detect that the user is not understanding something or not performing some aspect of the simulated welding procedure properly. In accordance with an embodiment, an intelligent agent is an autonomous entity, usually implemented in software, which observes and acts upon an environment and directs its activity towards achieving goals. An intelligent agent may be able to learn and use knowledge to achieve a goal (e.g., the goal of providing relevant feedback to a welding student or a welding educator). In accordance with an embodiment of the present invention, the environment perceived and acted upon by an intelligent agent is the virtual reality environment generated by the VRAW system 2500, for example.

[0156] The IA 2550 may subsequently interrupt the simulated welding procedure, notify the user of the problem, and automatically direct the user to an appropriate web site of the plurality of pre-identified web sites in an attempt to help the user. The web sites may provide written instructions, graphical instructions, video instructions, or any other type of appropriate instructional format that can be accommodated over the internet connection.

[0157] As an example, the IA 2550 may detect that the user is not holding the mock welding tool at the proper angle and may display a message to the user saying, for example, "You seem to be having trouble holding the mock welding tool at the proper angle. I will now direct you to a web site showing a video of the proper orientation for the welding tool for the present welding procedure". The system 2500 may proceed to access the web site at the direction of the IA 2550 using the CC 2510. The system may even automatically select and play the video for the user. Alternatively, the user may select and play the video once at the web site.

[0158] In accordance with an embodiment, the system includes a speaker 2520, a microphone 2530, and a video camera 2540, as illustrated in FIG. 25, which may be used to facilitate communication between a user of the virtual reality arc welding system 2500 and a welding instructor at a remote site. The welding instructor may be connected to the internet via a hand-held mobile device or a desktop personal computer, for example. Communication may be in real time over the external communication infrastructure 2600 using the CC 2510, allowing a welding instructor to provide real-time instruction to a welding student (user) while the welding student is performing a simulated welding process.

[0159] In accordance with an embodiment, the microphone 2530 receives sound waves from the user's voice and the video camera 2540 provides video images of the user in real time. The PPS 110 is configured to transform the user's voice and video images into digital data that may be transmitted over the external communication infrastructure 2600 to the welding instructor using the CC 2510. Similarly, the welding instructor's voice may be heard over the speaker

**2520** after receiving digital data representative of the welding instructor's voice over the external communication infrastructure **2600** using the CC **2510**, and after the PPS **110** transforms the digital data to electrical signals which drive the speaker **2520**. Furthermore, video images of the welding instructor may be viewed on the ODD **150**, for example, after receiving digital data representative of the video images over the external communication infrastructure **2600** using the CC **2510**, and after the PPS **110** transforms the digital data to electrical signals which are displayed on the ODD **150**.

**[0160]** In accordance with an embodiment, a user of a remote device **2610** may send commands from the remote device to the virtual reality welding system **2500** over the external communication infrastructure **2600**. The commands are received by the PPS **110** through the CC **2510**. A user of a remote device may send commands to facilitate remote troubleshooting of the virtual reality welding system **2500**, for example. For example, a system technician may command that certain diagnostic procedures be run on the virtual reality welding simulator **2500**. The PPS **110** may send results of the diagnostic procedures back to the remote device **2610**. Furthermore, a user of a remote device may send commands to change settings of the virtual reality welding simulator **2500**. For example, a welding instructor using a remote device at a remote location may set up a welding scenario for a welding student on the virtual reality welding system by changing the settings over the external communication infrastructure **2600**. Other settings that may be changed include, for example, positions of the table **171** and the arm **173**, a wire feed speed, a voltage level, an amperage, a polarity, and turning particular visual cues on or off.

**[0161]** Another embodiment provides a virtual reality arc welding system. The system includes a programmable processor-based subsystem, a spatial tracker operatively connected to the programmable processor-based subsystem, at least one mock welding tool configured to be spatially tracked by the spatial tracker, and at least one display device operatively connected to the programmable processor-based subsystem. The system is configured to simulate, in a virtual reality environment, a weld puddle that is responsive to manipulation of the at least one mock welding tool by a user and has real-time molten metal fluidity and heat dissipation characteristics, and display the simulated weld puddle on the at least one display device in real-time. The system is further configured to overlay and display an image of an ideal weld puddle onto the simulated weld puddle when at least one characteristic of the simulated weld puddle deviates more than a determined amount from an ideal amount of the at least one characteristic. The at least one characteristic of the simulated weld puddle may include one or more of a shape, a color, slag, a size, viscosity, heat dissipation, puddle wake, and dime spacing. In accordance with various embodiments, the image of the ideal weld puddle may be a partially transparent, ghosted image or an opaque image. The system may further be configured to overlay and display a partially transparent, ghosted image of an ideal weld puddle onto the simulated weld puddle at least during a first portion of a simulated welding process.

**[0162]** FIG. 27 illustrates an example embodiment of a displayed virtual weld **2700**, being created using the system **100** during a virtual welding process, showing a simulated weld puddle **2710**. In accordance with an embodiment, a

simulated weld puddle may have various characteristics such as, for example, shape, color, slag, size, fluidity/viscosity, heat dissipation, puddle wake, and dime spacing. For a particular welding process, these characteristics ideally conform to particular defined ranges or values for an ideal weld puddle.

**[0163]** As an example, in FIG. 27, certain characteristics of the simulated weld puddle **2710** deviate from an ideal weld puddle for the virtual welding process in that the shape of the simulated weld puddle **2710** is too wide and the displayed heat dissipation characteristics are improper. Such deviation may be due to poor user technique of the mock welding tool, for example. Therefore, in accordance with an embodiment, an image of an ideal weld puddle may be overlaid and displayed onto the simulated weld puddle **2710** in real time during the simulated welding process to direct and encourage the user to modify his technique to more accurately match the resultant simulated weld puddle **2710** to the ideal weld puddle.

**[0164]** In accordance with an embodiment, the PPS **110** of the virtual reality arc welding system keeps track of values associated with the characteristics of the simulated weld puddle and compares the values to a set of ideal values for the particular welding process. The virtual reality welding system is configured to overlay and display an image of an ideal weld puddle onto the simulated weld puddle when at least one characteristic of the simulated weld puddle deviates more than a determined amount from an ideal value of the at least one characteristic.

**[0165]** FIG. 28 illustrates the displayed virtual weld **2700** of FIG. 27 with an image of an ideal weld puddle **2810** overlaid onto an image of the simulated weld puddle **2710**. In FIG. 28, the width of the ideal weld puddle **2810** is seen to be narrower than the width of the simulated weld puddle **2710**, and the displayed heat gradient of the ideal weld puddle **2810**, as illustrated by the changing shades of gray across the ideal weld puddle **2810**, is representative of proper heat dissipation for the virtual welding process. The displayed ideal weld puddle **2810** may be partially transparent, in accordance with an embodiment, such that the user can still see the simulated weld puddle **2710** through the ideal weld puddle **2810**, allowing the user to see how the characteristics of the simulated weld puddle **2710** approach the characteristics of the ideal weld puddle **2810** as the user modifies his welding technique.

**[0166]** Alternatively, the displayed ideal weld puddle **2810** may be opaque, in accordance with an alternative embodiment, such that at least a portion of the simulated weld puddle **2710** is covered up. In such an alternative embodiment, the ideal weld puddle **2810** may be intermittently displayed, allowing the user to intermittently view the full simulated weld puddle **2710** to determine how the characteristics of the simulated weld puddle **2710** are approaching the characteristics of the ideal weld puddle **2810** as the user modifies his welding technique.

**[0167]** In accordance with an embodiment, the image of the ideal weld puddle **2810**, whether partially transparent or opaque, may actually be real time moving video overlaid onto the simulated weld puddle **2710**, to show ideal molten metal fluidity and viscosity characteristics, for example. Therefore, as used herein with respect to an ideal weld puddle, the term "image" may refer to a single static image or dynamic video.

**[0168]** A further embodiment provides a virtual reality arc welding system. The system includes a programmable processor-based subsystem operable to execute coded instructions. The coded instructions include a rendering engine configured to generate a three-dimensional (3D) rendering of a virtual weldment created by a user on the virtual reality welding system. The coded instructions further include an analysis engine configured to perform simulated testing of the 3D virtual weldment and generate corresponding test data. The coded instructions also include at least one intelligent agent (IA) configured to generate recommended corrective actions for the user, based on at least the test data. The recommended corrective actions may include one or more of welding techniques of the user to be changed, training materials stored on the virtual reality welding system to be reviewed by the user, a customized training project to be completed by the user, and a setup of the virtual reality welding system to be changed by the user.

**[0169]** In accordance with an embodiment, an intelligent agent is an autonomous entity, usually implemented in software (coded instructions), which observes and acts upon an environment and directs its activity towards achieving goals. An intelligent agent may be able to learn and use knowledge to achieve a goal (e.g., the goal of providing relevant feedback to a welding student or a welding educator). In accordance with an embodiment of the present invention, the environment perceived and acted upon by an intelligent agent is the virtual reality environment generated by the VRAW system 2500, for example.

**[0170]** As an example, the analysis engine of the programmable processor-based subsystem may perform a simulated bend test on a 3D rendering of the virtual weldment as created by a welding student using the virtual reality welding system 2500. For example, referring to FIG. 22, a straight cut section of the virtual weldment 2200 having a virtual weld joint 2210 may be subjected to the simulated bend test. The bend test may be performed to find various weld properties such as ductility of the welded zone, weld penetration, fusion, crystalline structure (of the fractured surface), and strength. The bend test helps to determine the quality of the weld metal, the weld junction, and the heat affected zone. Any cracking of the metal during the bend test indicates poor fusion, poor penetration, or some other condition that can cause cracking. Stretching of the metal helps indicate the ductility of the weld. A fractured surface reveals the crystalline structure of the weld. Larger crystals tend to indicate a defective welding procedure or inadequate heat treatment after welding. A quality weld has small crystals. During the simulated bend test, test data is generated by the analysis engine.

**[0171]** In accordance with an embodiment, the intelligent agent 2550 is configured to generate recommended corrective actions for the user when the bend test reveals particular aspects of poor weld quality. The intelligent agent 2550 may use the test data generated during the simulated bend test, as well as other data (e.g., data collected in real time during the virtual welding process during which the virtual weldment was created such as, for example, an orientation of the mock welding tool) to generate the corrective actions. For example, the intelligent agent 2550 may generate changes to the welding student's welding technique which the welding student can practice to improve his welding technique. The changes to the student's welding technique may include, for example, the distance the student holds the end of the

welding electrode of the mock welding tool from the mock welding coupon and the angle at which the student holds the mock welding tool with respect to the mock welding coupon. Other welding technique changes may be recommended as well.

**[0172]** Furthermore, or alternatively, the intelligent agent 2550 may direct the welding student to particular training materials that are stored on the virtual reality arc welding system 2500. The training materials may include, for example, slide show presentations and videos dealing with specific aspects of a welding process. Other types of training materials are possible as well, in accordance with various embodiments. Also, the intelligent agent 2550 may generate a customized training project to be completed by the welding student. For example, the intelligent agent may determine that the student is having trouble achieving the proper amount of weld penetration. As a result, the intelligent agent may generate a training project that has the student practicing specific welding techniques on the virtual reality welding system to achieve proper weld penetration for one or more types of welding coupons and simulated welding processes.

**[0173]** Finally, the intelligent agent may generate a changed setup that the welding student should apply to the virtual reality welding system to improve the quality of the virtual weldment. The changed setup may direct the welding student to change, for example, a position of the mock welding coupon, positions of the table/stand (T/S), an amperage setting of the virtual reality welding system, a voltage setting of the virtual reality welding system, or a wire feed speed setting of the virtual reality welding system. Other setup aspects may be changed as well, in accordance with other various embodiments.

**[0174]** In accordance with an embodiment, the recommendations generated by the intelligent agent may be presented to the welding student on a display device of the virtual reality welding system. In accordance with an alternative embodiment, the virtual reality welding system may be configured to interface to a printer device and the recommendations may be printed for the user. Furthermore, the virtual reality welding system may be configured to store and display various welding procedure specifications and blueprints with welding symbols to aid a welding student in his training.

**[0175]** In accordance with an embodiment, the virtual reality welding system is configured to track the progress of the welding student as the welding student progresses through a training program using the virtual reality welding system, and recall the student's place in the training program. A training program may include a plurality of welding procedures and/or training modules. For example, the virtual reality welding system may provide a means for the welding student to identify himself to the virtual reality welding system. Such identification may be accomplished through one of various well known techniques such as, for example, scanning of a user badge or identification card (e.g., bar code scanning or magnetic strip scanning), biometric scanning of the student (e.g., retinal scanning), or manual entering of a student identification number. In accordance with the various embodiments, the virtual reality welding system is configured to accommodate the identifying techniques. For example, the virtual reality welding system may have an integrated bar code scanner or retinal scanner.



[0176] Once a student is identified, the virtual reality welding system may recall from memory the section of the training program where the welding student left off including, for example, the last welding setup of the virtual reality training system and the last virtual weld created. Furthermore, the virtual reality welding system may be configured to store the past welding procedures and training modules the welding student has completed to date, and allow the welding student to recall and display a history of the completed procedures and modules. In this manner, multiple students may use the same virtual reality welding system, at different times, while having the virtual reality training system separately track and remember the progress of each welding student.

[0177] Another embodiment provides a method. The method includes displaying a virtual welding environment to a user on one or more display devices of a virtual reality welding system, wherein the virtual welding environment is generated by the virtual reality welding system and simulates one or more unsafe conditions within the virtual welding environment. The method further includes allowing the user to proceed with performing a virtual welding activity using the virtual reality welding system after the user has correctly identified the one or more unsafe conditions to the virtual reality welding system via a user interface of the virtual reality welding system. The method may further include removing the one or more unsafe conditions from the virtual welding environment in response to the user correctly identifying the one or more unsafe conditions to the virtual reality welding system. The method may also include introducing one or more new unsafe conditions into the virtual welding environment during a welding activity performed by the user using the virtual reality welding system, wherein the one or more new unsafe conditions are automatically introduced by the virtual reality welding system. The method may further include introducing one or more new unsafe conditions into the virtual welding environment during a welding activity performed by the user using the virtual reality welding system, wherein the one or more new unsafe conditions are introduced by the virtual reality welding system in response to a command from a welding instructor.

[0178] In accordance with an embodiment, unsafe conditions in the virtual welding environment may include, for example, an improperly positioned exhaust hood presenting a fume exposure hazard, a wooden structure near the welding workpiece presenting a fire hazard, a loose or tenuous welding cable connection to the workpiece presenting an electrical shock hazard, water near the workpiece presenting a slipping hazard, unsecured welding gas cylinders presenting an explosive hazard, and an excessively confined welding area presenting an electrical shock hazard and/or a fume exposure hazard. Other types of unsafe conditions are possible as well, in accordance with various other embodiments.

[0179] As an example, a user viewing the virtual welding environment on a display device of the virtual reality welding system may observe an improperly positioned exhaust hood presenting a fume exposure hazard. In accordance with an embodiment, the user may place a cursor over the improperly placed exhaust hood on the display device using the user interface of the virtual reality welding system and select the exhaust hood. In this manner, the user identifies the unsafe condition of the improperly positioned exhaust hood to the virtual reality welding system. Upon

identifying the unsafe condition to the system, the system may properly position the exhaust hood in the virtual welding environment. If the improperly positioned exhaust hood was the only unsafe condition, then the user may proceed with performing a virtual welding activity using the virtual reality welding system. Other ways of identifying an unsafe condition to the virtual reality welding system are possible as well, in accordance with various other embodiments. Furthermore, in accordance with an embodiment, the virtual reality welding system may be configured to allow the user to properly position the exhaust hood in the virtual reality environment via the user interface.

[0180] As the user performs the virtual welding activity, the system may occasionally introduce a new unsafe condition into the virtual welding environment. Alternatively, a welding instructor may command the system to introduce a new unsafe condition using the user interface of the virtual reality welding system. As an example, as the user is performing the virtual welding activity, the welding cable connection to the workpiece may visibly become loose. If the user does not stop the virtual welding activity and identify the new unsafe condition to the system within a predetermined period of time, the system may provide an indication to the user that the user has failed to identify the new unsafe condition and may shut down the virtual welding process. In this manner, the user (e.g., a welding student) may learn to become aware of unsafe conditions in the welding environment.

[0181] A further embodiment provides a method. The method includes setting a plurality of welding parameters on a virtual reality welding system for a welding process, wherein at least one of the welding parameters is improperly set for the welding process. The method also includes a user performing a virtual welding activity using the virtual reality welding system having the set plurality of welding parameters to create a virtual weldment. The method further includes the user observing the virtual weldment on at least one display device of the virtual reality welding system and attempting to identify the at least one improperly set welding parameter based at least on the observing. The setting of the plurality of welding parameters may be performed by a welding instructor. Alternatively, the setting of the plurality of welding parameters may be performed automatically by the virtual reality welding system. The method may also include the user attempting to change the at least one improperly set welding parameter to a proper setting. One of the virtual reality welding system or a welding instructor may inform the user when the user has changed the at least one improperly set welding parameter to a proper setting.

[0182] In accordance with an embodiment, the plurality of welding parameters may include a wire feed speed, a voltage level, an amperage, and a polarity which are each settable on the welding user interface. Other settable welding parameters may be possible as well, in accordance with various other embodiments. As an example, the wire feed speed can be improperly set too high or too low for a particular welding process. Similarly, the voltage level and/or amperage can be improperly set too high or too low for a particular welding process. Furthermore, the polarity can be improperly set to the opposite polarity for a particular welding process. Setting one or more welding parameters incorrectly can result in a created virtual weld having defects and discontinuities. For example, setting the amperage too low

can result in a lack of penetration into the workpiece (as represented by the virtual welding coupon).

**[0183]** Therefore, in accordance with an embodiment, the user may observe the resultant virtual weldment to check for any defects or discontinuities. The user may even desire to perform a virtual destructive or non-destructive test on the virtual weldment, as described previously herein, to aid observation. Based on the user's observations of the virtual weldment and the user's knowledge of the relationship between welding parameters and welding defects and discontinuities, the user may identify one or more welding parameters that were improperly set. The user may change the one or more improperly set welding parameters to what the user believes to be the proper settings, and proceed to re-create the virtual weldment, hopefully without the previous defects or discontinuities. In accordance with an embodiment, the virtual reality welding system is configured to inform the user (e.g., by displaying a message to the user on a display device of the system) that the parameters are now properly set for the selected welding process.

**[0184]** While the claimed subject matter of the present application has been described with reference to certain embodiments, it will be understood by those skilled in the art that various changes may be made and equivalents may be substituted without departing from the scope of the claimed subject matter. In addition, many modifications may be made to adapt a particular situation or material to the teachings of the claimed subject matter without departing from its scope. Therefore, it is intended that the claimed subject matter not be limited to the particular embodiments disclosed, but that the claimed subject matter will include all embodiments falling within the scope of the appended claims.

What is claimed is:

1. A simulated welding system, comprising:
  - a mock welding coupon;
  - a mock welding tool for simulating a welding process on the mock welding coupon, wherein the mock welding tool is configured to be spatially tracked by a spatial tracker when manipulated by a user relative to the mock welding coupon; and
  - a programmable processor-based subsystem operable to execute coded instructions, the coded instructions cause the programmable processor-based subsystem to:
    - simulate a weldment responsive to the user's manipulations of the mock welding tool relative to the mock welding coupon, wherein the weldment includes defects resulting from the manipulation, by the user, of the mock welding tool relative to the mock welding coupon;
    - simulate a test on said simulated weldment to generate test data corresponding to at least one characteristic of said simulated weldment, said at least one characteristic corresponding to a physical property of a weld;
    - compare said test data to predefined welding standards to determine whether there is a defect in said simulated weldment; and
    - output recommended corrective actions to a display based at least in part on said test data.
2. The system of claim 1, wherein the recommended corrective actions for the user include changes to the user's welding techniques.
3. The system of claim 1, wherein the recommended corrective actions for the user include training materials stored on the simulated welding system to be reviewed by the user.
4. The system of claim 1, wherein the recommended corrective actions for the user include a customized training project to be completed by the user.
5. The system of claim 1, wherein the recommended corrective actions include a setup of the simulated welding system to be changed by the user.
6. The system of claim 1, wherein the simulated test comprises a simulated bend test on weldment.
7. The system of claim 1, wherein the simulated test comprises a simulated pull test on the weldment.
8. The system of claim 1, wherein the simulated test comprises a simulated break test on the weldment.
9. The system of claim 1, wherein the simulated test comprises a simulated impact test on the weldment.
10. The system of claim 1, wherein the simulated test comprises a simulated hardness test on the weldment.
11. The system of claim 1, wherein the recommended corrective actions for the user are presented to the user on a display device of the simulated welding system.
12. The system of claim 1, wherein the system is configured to interface to a printer device and print the recommended corrective actions for the user.
13. The system of claim 1, wherein the system is configured to store and display welding procedure specifications and blueprints with welding symbols.
14. The system of claim 1, wherein the system is configured to track progress of the user as the user progresses through a training program using the system.
15. The system of claim 1, further comprising a bar code scanner.
16. The system of claim 1, further comprising a biometric scanner.
17. The system of claim 14, wherein the system recalls from memory a section of the training program that the user last initiated.
18. The system of claim 17, wherein the section of the training program is a welding setup of the system.
19. The system of claim 17, wherein the section of the training program is a virtual weld that the user last created.
20. The system of claim 1, wherein the system allows the user to recall and display a history of completed procedures and modules.
21. The system of claim 20, wherein the system separately tracks and recalls progress of each separate user.
22. A simulated welding method, comprising the steps of:
  - providing a simulated welding system, comprising:
    - a mock welding coupon;
    - a mock welding tool for simulating a welding process on the mock welding coupon, wherein the mock welding tool is configured to be spatially tracked by a spatial tracker when manipulated by a user relative to the mock welding coupon; and
    - a programmable processor-based subsystem operable to execute coded instructions;
  - simulating, by the simulated welding system, creation of weldment responsive to the user's manipulation of the mock welding tool relative to the mock welding coupon, wherein the weldment includes defects resulting from the manipulation, by the user, of the mock welding tool relative to the mock welding coupon;

simulate a test on said simulated weldment to generate test data corresponding to at least one characteristic of said simulated weldment, said at least one characteristic corresponding to a physical property of a weld; compare said test data to predefined welding standards to determine whether there is a defect in said simulated weldment; and output recommended corrective actions to a display based at least in part on said test data.

**23.** A method for simulating welding activity, comprising: spatially tracking a mock welding tool relative to a mock welding coupon for a simulated welding operation; receiving information related to said spatial tracking of said mock welding tool during said simulated welding operation; simulating a weldment based on said received information during said simulated welding operation; simulating a test on said simulated weldment to generate test data corresponding to at least one characteristic of said simulated weldment, said at least one characteristic corresponding to a physical property of a weld; comparing said test data to predefined welding standards to determine whether there is a defect in said simulated weldment; and outputting a recommended corrective action to a display based at least in part on said test data.

\* \* \* \* \*